

OPERATING INSTRUCTIONS

Mustard Dispenser Model No. 141-D & 141-DL (w/legs)



The Prince Castle Mustard Dispenser is portion control at its finest. A simple five-hole diffuser dispenses mustard evenly, while handle makes holding dispenser comfortable. Built from stainless-steel and food-approved rubber, the Mustard Dispenser is virtually indestructible. Simple parts make assembly and cleaning as easy as 1-2-3.

TABLE OF CONTENTS

PAGE

Installation	2
Operating	2
Cleaning	2
Proper Maintenance	3
Parts List.....	3 & 4

LIMITED WARRANTY

This product is warranted to be free from defects in material and/or workmanship for a period of one year from the date of original installation. Any component which proves to be faulty during the warranty period will be replaced without cost to the customer.

SPECIFICATION

141-D

Handle
Diameter
Height
Shipping Weight

Dimensions

6" (15.22 cm)
7" (17.78 cm)
6 1/2" (16.51 cm)
21/2lbs. (1.13 kg.)

INSTALLATION

1. After you have removed the mixer from the carton, inspect the unit for signs of damage. If there is damage to the unit:
 - Notify carrier within 24 hours after delivery.
 - Save carton and packing materials for inspection purposes.
 - Contact your Prince Castle Dealer for replacement or the the Prince Castle Customer Sales Department at 1-800-722-7853 if purchased directly.
2. Verify that all parts have been received.
3. Wash all parts before using.
4. Moisten the diffuser in water. Bend the diffuser between thumb and forefinger so it bends into an oval shape over the middle finger. Work the crease in the edge of diffuser little by little around the metal rim of the opening in bottom of container. See figure 1.

figure 1

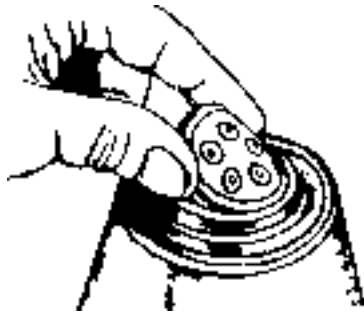

5. Place dispenser without legs in Prep Pan, or dispenser with legs on a flat surface.

figure 2



6. Assemble cylinder, spring and piston assembly. See figure 2.

figure 3

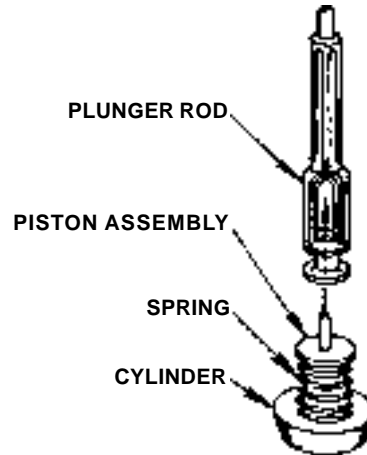

7. Assemble plunger rod to the piston by pressing the rod into the piston pin. See figure 3.
8. Insert assembly into shell. Make sure cylinder, spring and piston are nested over diffuser.
9. Make sure there is a tray or towel under dispenser. (Do to consistency, mustard may drip.)
10. Fill dispenser.
11. Assemble the activating lever (item A) through the lever stop. Guide the plunger rod (item B) into the

figure 4

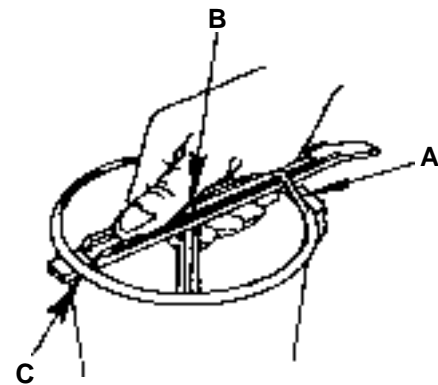

center hole. Push down against the springing action of the piston, and guide the end of the lever into the TEE slot of the container. See figure 4.

OPERATION

1. The dispenser must be primed after filling. Hold lever down to force air out of cylinder. Shake dispenser side to side or swirl (or both) to remove air trapped around spring and cylinder area due to thickness of mustard.
2. Pump dispenser a number of times to prime. If dispenser is not working properly alternate pumping and shaking.

IMPORTANT: If dispenser is not primed air in the piston, cylinder and diffuser area will cause improper operation

3. Depressing the actuating lever one time will deliver approximately 1/28 oz. of mustard.

CLEANING

1. Remove mustard from container.
2. Fill with warm water and press actuating lever several times to pump water through dispenser.
3. Disassemble all parts and wash thoroughly.

TROUBLESHOOTING

1. Use mustard which is at room temperature.

2. Rotate rubber diffuser daily. Allow one diffuser to dry out while using another one. This helps diffuser maintain its shape for proper dispensing.
3. To check if diffuser is working properly, assemble without any mustard. Turn the dispenser upside-

figure 5

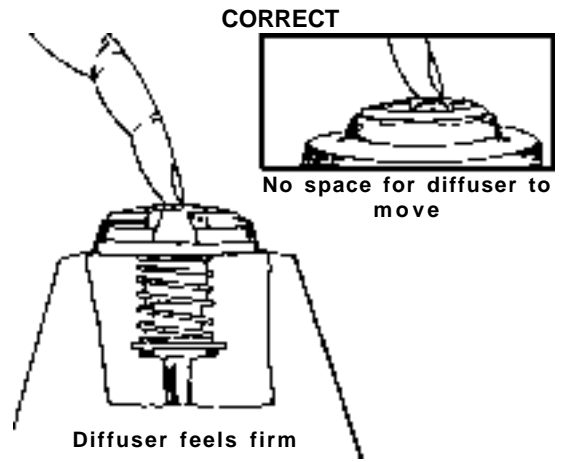

down, press down on the center of the diffuser. There should not be any movement between the diffuser and the center of the plastic cylinder. See figure 5.

figure 6

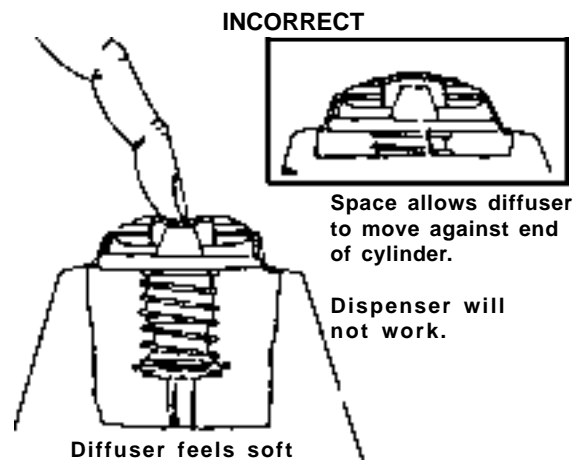

4. If there is movement between the diffuser and the plastic cylinder, or if diffuser is soft, it should be replaced. See figure 6.

MUSTARD DISPENSER 141-D EXPLODED VIEW

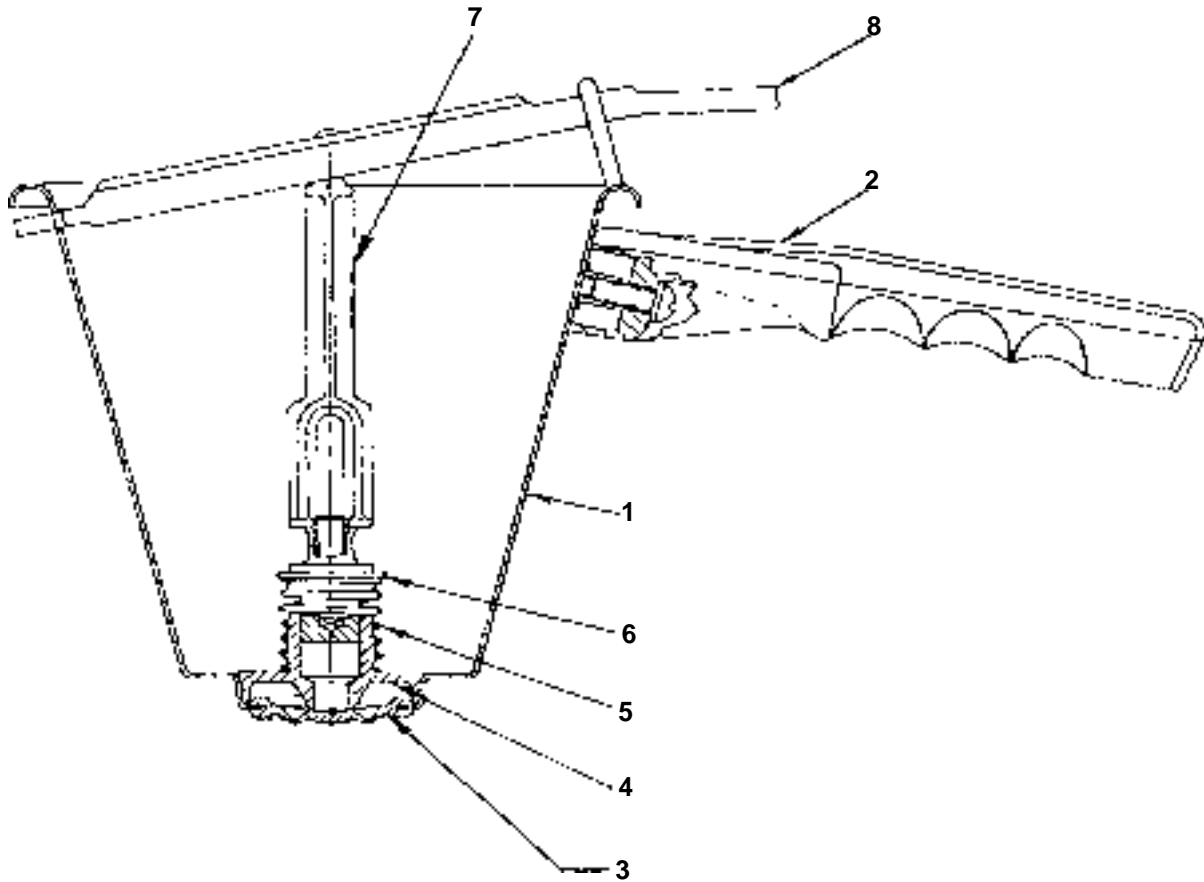

PARTS LIST

ITEM	PART NO.	DESCRIPTION
1	101-108	Shell Assembly (141-D)
	101-114	Shell Assembly (141-DL)
2	141-32	Replacement Handle Kit
3	141-4YS	Yellow Diffuser (Pakage of 3)
4	141-2	Cylinder
5	141-5	Piston Return Spring
6	141-51	Piston
7	101-107	Plunger Rod
8	141-61	Actuating Lever (Metal)