

INSTALLATION, OPERATION & MAINTENANCE MANUAL

PREMIER SERIES HIGH PERFORMANCE GAS CONVECTION OVEN

MODELS: ○ 2900
○ 2992



WARNING:

Improper installation, adjustment, alteration, service or maintenance can cause property damage, injury or death. Read these installation, operation and maintenance instructions thoroughly before installing or servicing this equipment.

FOR YOUR SAFETY:

Do not store or use gasoline or other flammable vapors or liquids in the vicinity of this or any other appliance.



MARKET FORGE
INDUSTRIES INC.

An Employee Owned Company

Form Number: S-2552 05/04

Printed in U.S.A.

35 Garvey Street • Everett • MA • 02149
Tel: (617) 387-4100 • Fax: 1-800-227-2659 (Ex. MA) • (617) 387-4456 (MA and Overseas)

E-Mail: CUSTSERV@mfi.com • Website: www.mfi.com

TABLE OF CONTENTS

INTRODUCTION	ii
IMPORTANT	ii
INSTALLATION, OPERATION & SERVICE PERSONNEL	ii
SHIPPING DAMAGE CLAIM PROCEDURE	ii
GENERAL	1
RATING PLATE	1
CLEARANCE	1
ASSEMBLY	2
SINGLE OVEN	2
DOUBLE OVEN	3
CASTER INSTALLATION	3
IMPORTANT	4
LEVELING	4
AIR SUPPLY & VENTILATION	4
ELECTRICAL CONNECTION	4
GAS CONNECTION	5
MANUAL SHUT-OFF VALVE	5
CONNECTION	5
FLEXIBLE COUPLING, CONNECTIONS & CASTERS	6
INITIAL PILOT LIGHTING	6
TO CHECK FOR GAS LEAKS	6
FINAL PREPARATION	6
CLEANING & MAINTENANCE	7
CLEANING	7
OVENS	7
STAINLESS STEEL	7
PERIODIC MAINTENANCE	7
PARTS LIST	10

LIST OF ILLUSTRATIONS

ASSEMBLY	2
FIG. 2 STAND	2
FIG. 2 STACKED OVEN	3
WIRING DIAGRAM	8
PARTS LIST EXPLODED VIEW	9

INTRODUCTION

Instructions to be followed in the event the user smells gas, shall be posted in a prominent location in the kitchen area. This information shall be obtained by consulting the local gas supplier. Retain this manual for future reference.

IMPORTANT:

Safe and satisfactory operation of your equipment depends on proper installation. Installation must conform with local codes, or in the absence of local codes, the **National Fuel Gas Code, (ANSI Z-223.1 Latest Edition)**. In Canada installation should conform to installation codes for gas burning appliances and equipment standard (**CAN1-B149.1 Natural Gas**) or (**CAN1-B149.2 Propane Gas**).

Electrical wiring from the Electric Meter, main control box or service outlet to appliance must be electrically grounded in accordance with local codes or, in the absence of local codes, the **National Electric Code (ANSI/NFPA 70 Current)**. In Canada wiring should conform with **Canadian Electrical Code (CSA-C22.1)**.

INSTALLATION, OPERATION & SERVICE PERSONNEL:

Installation of the equipment should be performed by qualified, certified, licensed and/or authorized personnel who are familiar with and experienced in state/local installation codes.

Operation of the equipment should be performed by qualified and authorized personnel who have read this manual and are familiar with the functions of the equipment.

Service of the equipment should be performed by qualified personnel who are knowledgeable with Market Forge cooking equipment.

SHIPPING DAMAGE CLAIM PROCEDURE:

The equipment is crafted and inspected carefully by skilled personnel before leaving the factory. The transportation company assumes full responsibility for safe delivery upon acceptance of this equipment. If shipment arrives damaged:

Visible loss or damage:

Note the damage or loss on freight bill or express delivery and signed by the person making the delivery.

File claim for damages immediately:
Regardless of the extent of damages.

Concealed loss or damage:

If damage is noticed after unpacking, notify the transportation company immediately and file a "Concealed Damage" claim with them. This should be done within fifteen (15) days from the date delivered. Retain container for inspection.

GENERAL

1. A Manual gas shut-off valve must be installed in the gas supply (service) line ahead of the appliance and gas pressure regulator for safety and ease in servicing.
2. The gas pressure regulator supplied must be installed on the appliance prior to connecting the equipment to the gas line. Failure to install a regulator will be potentially hazardous and will void the appliance warranty.
3. The appliance and its individual shut off valve must be disconnected from the gas supply piping system during any pressure testing of the system test pressure in excess of 1/2 PSI (3.45kpa).
4. The appliance must be isolated from gas supply piping system by closing its individual manual shut-off valve during any pressure testing of gas supply piping system at test pressure equal or less than 1/2 PSI (3.45kpa).
5. To perform maintenance and repairs of the appliance, please contact the factory, factory representative, or the nearest local authorized service company.

RATING PLATE:

The rating plate is located in front of the oven below the oven section. Information on this plate includes the model, serial number, BTU/hour input of the burners, operating gas pressure in WC and whether the appliance is orificed for Natural or Propane gas. Pilot lighting instructions are also located in the same area.

MARKET FORGE COOKING EQUIPMENT MUST BE CONNECTED TO THE TYPE OF GAS IDENTIFIED ON THE RATING PLATE ONLY.

CLEARANCE:

The appliance area must be kept free and clear of all combustibles. This unit is design-certified for the following installations only:

The clearances for combustibles and noncombustible construction are as follows:

Back / Combustible 6" & Noncombustible 0"
Side / Combustible 6" & Noncombustible 0"

DO NOT MOUNT over on a curb base. Use legs/casters provided. Adequate air space at the bottom and rear of the unit must be provided for proper venting of blower motor.

ASSEMBLY

6" leg assembly provided.

DO NOT USE door to lift or move oven.
All ovens must be installed on leg assembly/ casters shipped with unit.

The leg/stand assembly parts or casters are shipped separately.

SINGLE OVEN:

Assemble the leg/stand assembly as follows:

1. Remove legs from package.
2. Secure top frame parts to the legs with

bolts provided (**long angle** - front and back. **short angle** - sides).

3. Place the oven on top of leg/stand assembly. Match holes on the frame with oven bottom base. Fasten with bolts provided.

If provided with optional bottom shelf and rack support (*Fig. 1*)

- a. Screw the bottom shelf to the legs.
- b. Screw rack guide support angles to bottom shelf and top leg frame.

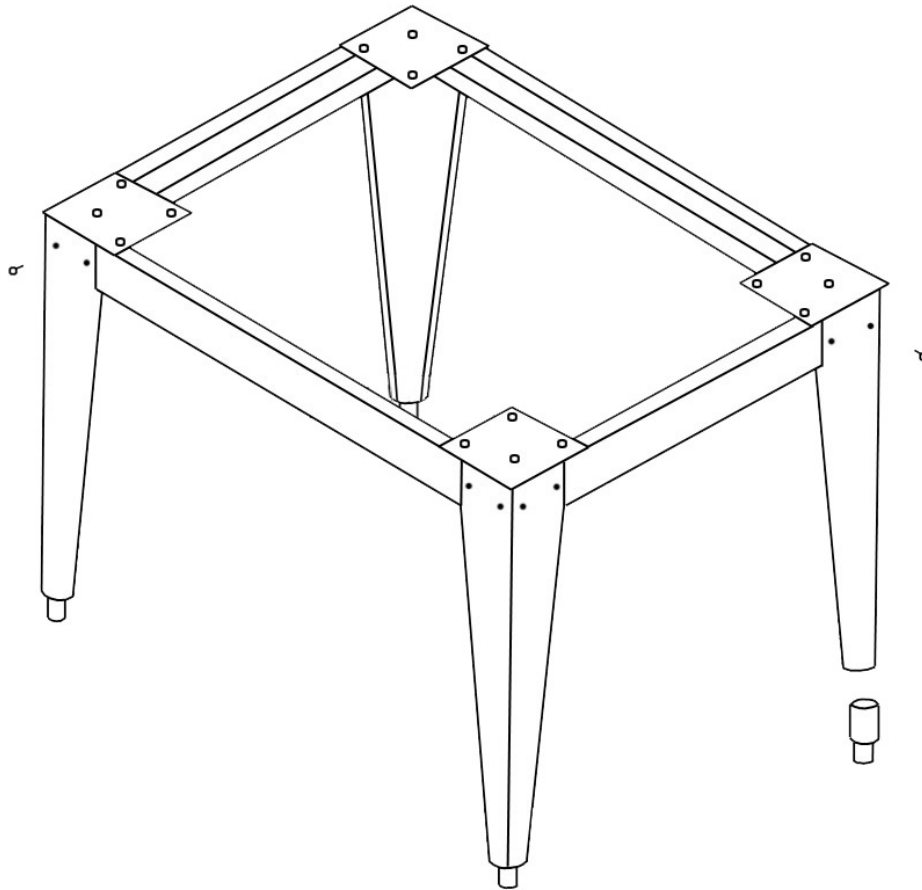

Fig. 1

ASSEMBLY

6" leg assembly provided.

DOUBLE OVEN:

1. Match holes on the legs with oven bottom base and screw with bolts provided.
2. Set top oven on top of bottom oven.
3. Bolt down at rear and front as shown in (Fig. 2). Remove top kick plate to access screwing the front bolts.
4. Assemble bottom flue extension as shown in (Fig. 2).

CASTER INSTALLATION:

If casters are provided, match holes on the caster with the holes on the oven bottom base and fasten with bolts provided.

NOTE: Front casters are locking type.

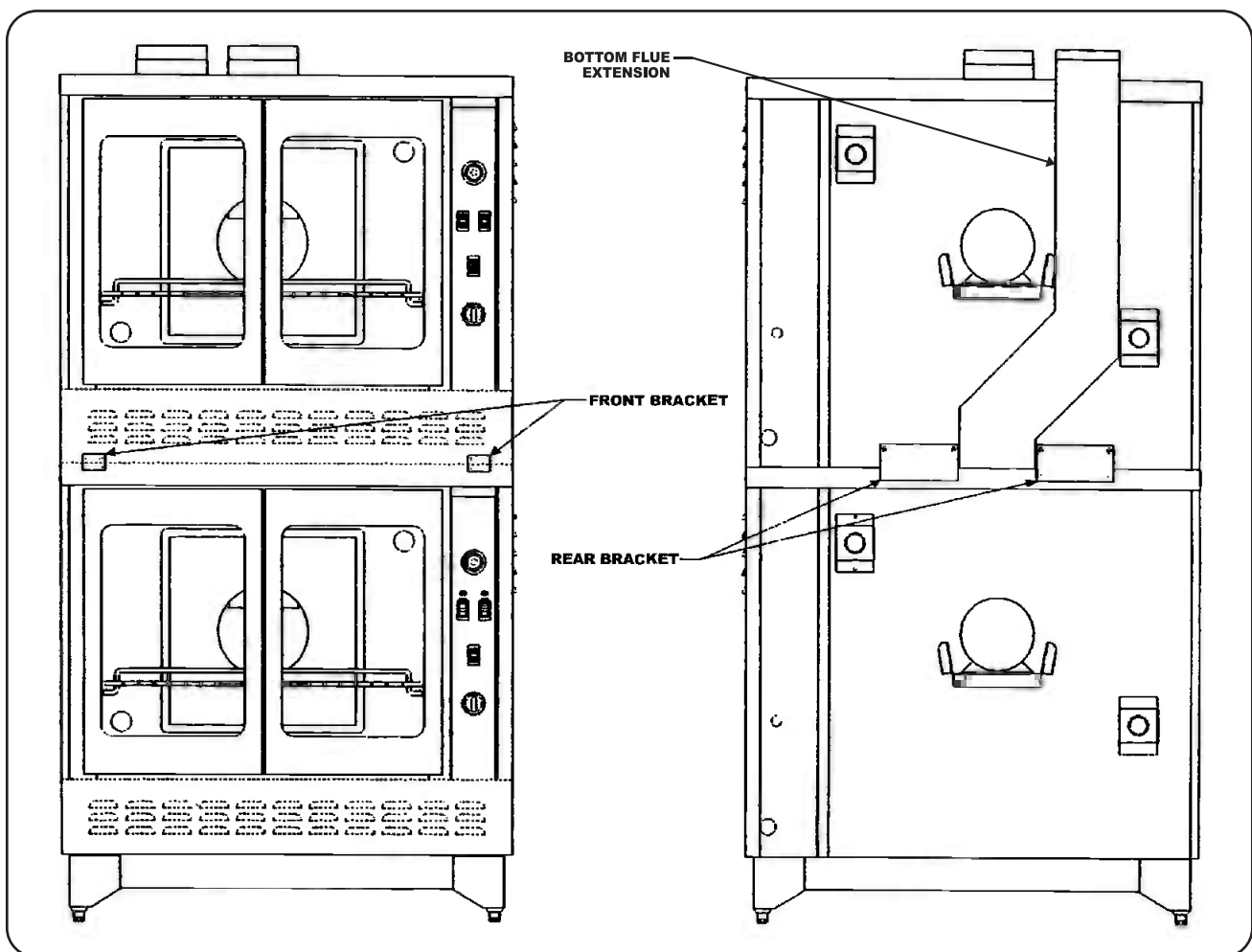

Fig. 2

IMPORTANT

LEVELING:

A carpenter's level should be placed on the oven's center baking rack and the unit leveled both front-to-back and side-to-side. If it is not level, cakes, casseroles, and any other liquid or semi-liquid batter will not bake evenly, burner combustion may be erratic, and the unit will not function efficiently.

Units with casters must be leveled with shims. A unit will probably not return to the same position after being moved, requiring re-leveling after each and every move.

AIR SUPPLY & VENTILATION:

The area, around and above the appliance must be kept clear to avoid any obstruction of air flow needed for combustion and ventilation. Adequate clearance must be maintained at all times in front and at the sides of the appliances for servicing and proper operation.

Means must be provided for any commercial, heavy-duty cooking appliance to exhaust combustion waste products to the outside of the building. Usual practice is to place the unit under an exhaust hood that complies with your local codes.

Strong exhaust fans in this hood or in the overall air conditioning system can produce a slight vacuum in the room and/or cause air drafts, either of which can interfere with pilot or burner performance and can also be hard to diagnose. Air movement should be checked during installation; if pilot or burner outage problems persist, make-up air openings or baffles may have to be provided in the room.

ELECTRICAL CONNECTION:

Market Forge convection oven requires a 120 volt supply to operate the ignition system and circulating fan. The supply cord provided along with the appliance is equipped with a three prong (*grounding*) plug for protection against shock hazard. The electrical service in the building must be equipped with a properly grounded three prong receptacle, in accordance with local codes, or in the absence of local codes, with the national electrical code, **ANSI/NFPA 70-1987**. In Canada, conform with Canadian electrical codes, **CAS-C22.1**.

Do not cut or remove the grounding prong from this plug. Wiring diagram is located on the back side of the appliance. **Disconnect power supply before cleaning or servicing.**

NOTE:

This appliance is not capable of being operated in the event of power failure. No attempt should be made to operate this appliance during a power failure.

IMPORTANT

GAS CONNECTION:

- Single Deck oven requires one gas connection.
- Double Deck oven requires two gas connections.

NOTE:

The gas supply (service) line must be the same size or greater than the inlet line of appliance. Market Forge ovens use a 3/4" NPT inlet. Sealant on all pipe joints must be resistive to LP gas.

MANUAL SHUT - OFF VALVE:

This installer-supplied valve must be installed in the gas service line ahead of the appliance and regulator in the gas stream and in a position accessible in the event of an emergency.

Failure to install the pressure regulator will void the equipment warranty!

The regulators supplied with Market Forge Ovens, have 3/4" inlet/outlet openings and are adjusted at the factory for 5" WC (*Natural gas*) or 10" WC (*Propane gas*) depending on the ovens gas type.

Prior to connecting the regulator, check the incoming line pressure, as these regulators can only withstand a maximum pressure of 1/2 PSI (14"WC). If the line pressure is beyond this limit, a step-down regulator will be required. The arrow shown on the bottom of the regulator body shows gas flow direction; it should point downstream to the appliance. The red air vent cap on the top regulator is part of the regulator and should not be removed. Any adjustments to regulators must be made **only** by qualified service personnel with the proper equipment.

CONNECTIONS:

Please check installer-supplied intake pipes visually and/or blow them out with compressed air to clear any dirt particles, threading chips, or other foreign matter before installing a service line. When gas pressure is applied these particles can clog orifices.

All connections must be sealed with a joint compound suitable for LP gas, and all connections must be tested with a soapy water solution before lighting any pilots!

CAUTION:

When lighting pilots and checking for leaks, do **not** stand with your face close to the combustion chamber.

All Market Forge appliances are adjusted and tested before leaving the factory, effectively matching them to sea level conditions.

Adjustments and calibrations to assure proper operation may be necessary on installation to meet local conditions. Low gas characteristics, to correct possible problems caused by rough handling or vibration during shipment are to be performed only by qualified service personnel. These adjustments are the responsibility of the customer and/or dealer and are not covered by our warranty.

Check all gas connections for leaks with a soapy water solution before lighting any pilots. **DO NOT USE AN OPEN FLAME TO CHECK FOR LEAKS!** Putting an open flame beside a new gas connection is extremely dangerous.

IMPORTANT

FLEXIBLE COUPLING, CONNECTORS AND CASTERS:

If the unit is to be installed with flexible couplings and/or quick-disconnect fittings, the installer must use a heavy-duty, AGA design-certified commercial flexible connector of at least 3/4" NPT (*with suitable strain relief*). The flexible connector must comply with the standard for **Connectors for Movable Gas Appliances, ANSI Z21.69** and addendum **Z21.69a** (*or latest edition*) the quick-disconnect device must comply with the standard for quick-disconnect devices for use with Gas Fuel should comply with **ANSI Z21.41** and addendum **Z21.41a** (*or latest edition*). Domestic gas or water connections are not suitable. If the disconnection of the restraint is necessary, make sure to reconnect the restraint after the appliance has been returned to its originally installed position.

The restraint device may be attached to the back frame/panel of unit.

If the unit is to be installed with casters, a flexible connector must be used with a suitable strain relief and the same **ANSI** standards apply.

Locking front casters are provided to limit the movement of the unit without depending on the connector, associated piping, or strain relief.

INITIAL PILOT LIGHTING:

- a. Turn the thermostat dial to the OFF position. Place the power switch to the OFF position
- b. Wait FIVE minutes.
- c. Place power switch to the ON position. Turn the oven thermostat to the desired temperature.

- d. For a complete shutdown, place the thermostat and power switch to the OFF position.

TO CHECK FOR GAS LEAKS:

1. Remove the kick plate and right side front panel.
2. Check gas piping prior to the valve with a soapy water solution.
3. Light the pilot as described above.
4. Turn the thermostat to any setting and the burner should light.
5. Check pilot tubing and burner tubing for leaks at the connectors with a soapy water solution.
6. Check the burner orifice elbow connection downstream of the valve with a soapy water solution.
7. Check the burner visually for a blue flame. There should be no yellow tips or soot. If yellow tipping occurs, call an authorized service person to adjust the burner air shutter.

FINAL PREPARATION:

On initial installation, turn the oven to 250° and operate for about 1 hour, then reset the thermostat to its maximum and operate for another hour.

At the end of this second hour, turn the thermostat OFF, open the door and allow the unit to cool. Oven should then be thoroughly washed using hot, soapy water before being used.

CLEANING & MAINTENANCE

Any piece of equipment works better and lasts longer when maintained properly. Cooking equipment is no exception. Your Market Forge oven must be kept clean during the working day and thoroughly cleaned at the end of the day.

CAUTION:

NEVER USE AMMONIA IN AN OVEN THAT IS WARMER THAN ROOM TEMPERATURE AND ALWAYS HAVE DIRECT VENTILATION!

CLEANING:

OVENS:

1. Remove the baking racks. Wash in hot soapy water and replace after the rest of the oven is cleaned.
2. Scrape off any food particles with a nylon griddle scraper. Be very careful about scraping the porcelain finish on the oven liner panels.
3. Wash all the above with hot soapy water, then reassemble.
4. Baked on spills may be loosened and stubborn stains removed with ordinary household ammonia and scrubbing with a nylon pad in a cold oven only.
5. Do not allow spray type oven cleaners to come into contact with the temperature probe in the oven.
6. After cleaning the oven, rinse well with 1/4 cup of vinegar to one quart of water solution to neutralize any caustic residue of the cleaning compound. Wipe dry.

STAINLESS STEEL:

All stainless steel body parts should be wiped regularly with hot soapy water during the day and with a liquid cleaner designed for this material at the end of each day.

DO NOT USE steel wool, abrasive cloths, cleaners or powders to clean stainless surfaces. If necessary to scrape stainless steel to remove encrusted materials, soak in hot water to loosen the material, then use a wooden nylon scraper. **DO NOT USE** a metal knife, spatula, or any other metal to scrape stainless steel. Scrape marks are almost impossible to remove.

PERIODIC MAINTENANCE:

Check the ventilation system periodically to see that nothing has fallen down into the exhaust vents. Lubricate the pivot pins of the oven door hinge. Use a multi-purpose lubricating oil sparingly so as to not drip oil needlessly. Your appliance should be checked for safe and efficient operation at least once a year by qualified service personnel.

Contact the factory, the factory representative or a local service company to perform all maintenance and repairs.

WIRING DIAGRAM

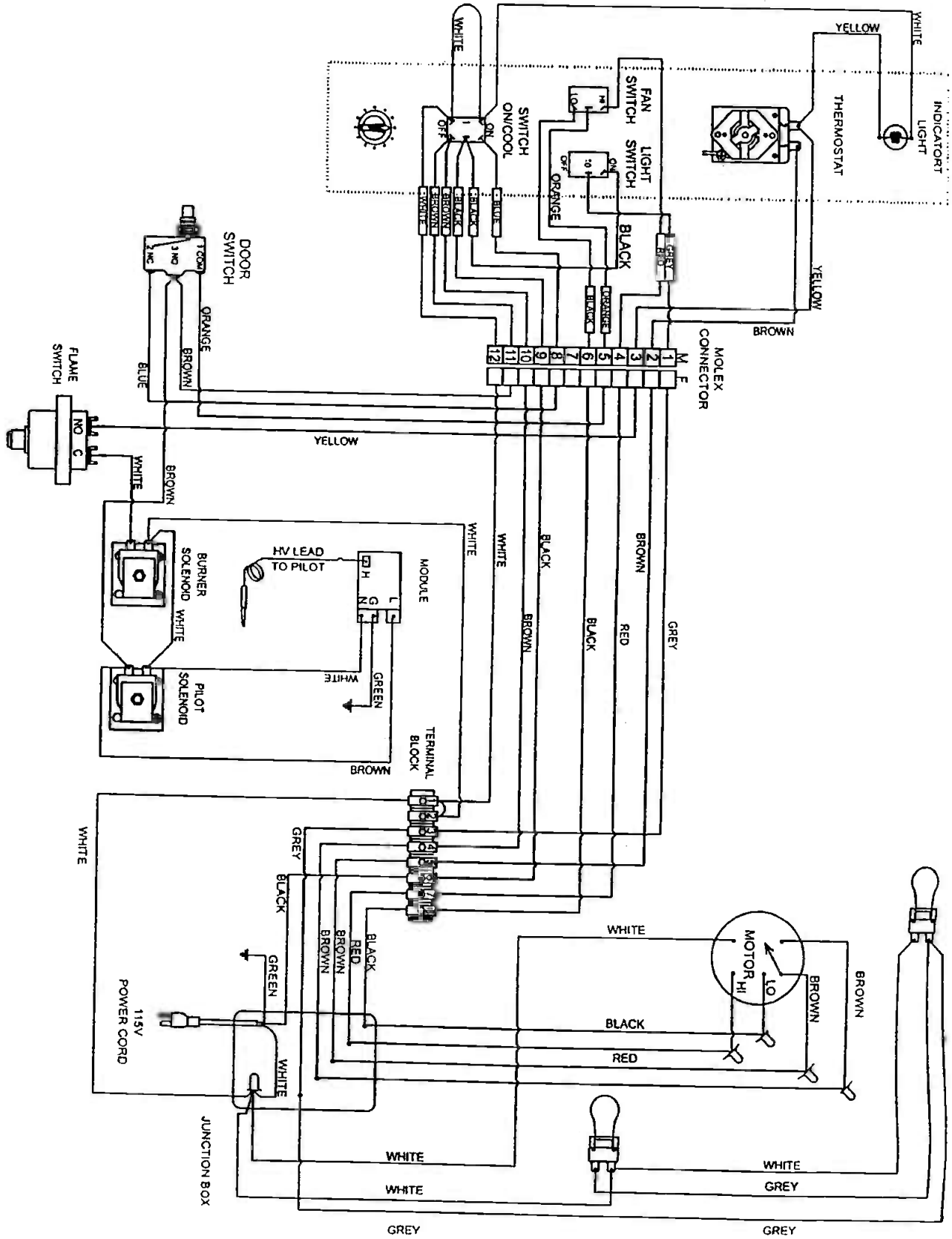

PARTS LIST

ITEM #	REF #	PART #	DESCRIPTION	QTY.
1	TS-1164	93 - 0025	MOTOR	1
2	TS-1164A	93 - 0026	MOTOR BRACKET	1
3	TS-1157A	93 - 0021	LIGHT BOX	1
4	TS-1158	93 - 0022	LIGHT SOCKET	1
5	TS-1157	93 - 0020	LIGHT BULB	1
6	TS-22130	93 - 0046	LIGHT COVER	1
7	TS-1142	93 - 0019	POWER CORD, 6'	1
8	TS-22296	93 - 0067	RIGHT SIDE PANEL - REAR	1
9	TS-22097	93 - 0055	RIGHT SIDE PANEL - FRONT	1
10	TS-1136	93 - 0017	TERMINAL BLOCK (8-WAY)	1
11	TS-1140	93 - 0018	IGNITOR MODULE, 0+1 SPARK	1
12	TS-1133	93 - 0015	FLAME SWITCH, FSS, 36" CAPILLARY	1
13	TS-1050	93 - 0004	REGULATOR (NAT)	1
	TS-1051	93 - 0005	REGULATOR (LP)	1
14	TS-30714	93 - 0079	PIPE EXTENSION, 3/4 NPT x 18" (GAS INLET)	1
15	TS-1134	93 - 0016	SOLENOID, FJ GAS	1
16	TS-1609	93 - 0031	PILOT VALVE - 1/8 NPT x 3/16 CC x 90 DEG.	1
	TS-1630	93 - 0032	FERRULE - 3/16 CC	1
	TS-1636	93 - 0034	COMPRESSION FITTING - 3/16 CC	1
17	TS-1700-31	93 - 0036	ORIFICE HOOD - #31 (45,000 BTU EACH - NAT.	1
	TS-1700-50	93 - 0037	ORIFICE HOOD - #50 (30,000 BTU EACH - LP.	1
	TS-1700-65	93 - 0038	BLANK ORIFICE HOOD - #65	1
18	TS-23094	93 - 0071	ORIFICE HOOD ADAPTER - 1/8 NPT x 3/8-27 STRAIGHT	1
19	TS-22294	93 - 0066	MANIFOLD PIPE 1/2 NPT	1
20	TS-22090	93 - 0054	CONTROL PANEL	1
21	TS-1086	93 - 0008	DECAL (CONTROL PANEL)	1
22	TS-1124	93 - 0011	INDICATOR LIGHT	1
23	TS-1161	93 - 0024	KNOB - THERMOSTAT	1
24	TS-1127	93 - 0013	SWITCH, FAN - 2-SPEED	1
	TS-1128	93 - 0014	SWITCH, LIGHT - MOMENTARY OVEN LIGHT SWITCH	1
	TS-1126	93 - 0012	SWITCH, POWER - 3 POSITION, ON-OFF-COOL DOWN	1
25	TS-1169	93 - 0028	KNOB - TIMER	1
26	TS-1170	93 - 0029	TIMER	1
27	TS-1160	93 - 0023	THERMOSTAT	1
28	TS-1355	93 - 0030	DOOR SWITCH - PLUNGER STYLE	1
29	TS-22124	93 - 0063	KICK PLATE	1
30	TS-22112	93 - 0059	DOOR ASSY. - R/H WITH GLASS	1
	TS-22109	93 - 0057	DOOR ASSY. - R/H WITH NO GLASS	1
	TS-1860	93 - 0044	GLASS WINDOW ASSY. ONLY	1
31	TS-22117	93 - 0060	HANDLE - OVEN DOOR	1
32	TS-22209	93 - 0065	DOOR ASSY. - L/H WITH GLASS	1
	TS-22111	93 - 0058	DOOR ASSY. - L/H WITH NO GLASS	1

PARTS LIST

ITEM #	REF #	PART #	DESCRIPTION	QTY.
33	TS-22122	93 - 0061	DOOR SEAL - SIDES	1
34	TS-22123	93 - 0062	DOOR SEAL - TOP & BOTTOM	1
35	TS-1851	93 - 0040	CHAIN, HT HD PRE STRETCHED	1
	TS-1852	93 - 0041	LINK ROD, 1/4 x 3" W/EYE COUPLER	1
	TS-1853	93 - 0042	LINK ROD, 1/4 x 20" W/EYE COUPLER	1
	TS-1854	93 - 0043	TURN BUCKLE	1
36	TS-22104	93 - 0056	DOOR CHAIN SPROCKET HOLDER	1
37	TS-23011	93 - 0070	CHANNEL SPROCKET SUPPORT	1
38	TS-1840	93 - 0039	BUSHING, 1/2" DIA., BRONZE	1
39	TS-22080	93 - 0052	BLOWER BAFFLE	1
40	TS-22081	93 - 0053	SNORKLE TUBE ASSY.	1
41	TS-1166	93 - 0027	BLOWER WHEEL	1
42	TS-1904	93 - 0045	BOLT, 1/4-20 x 5, HEX HEAD	1
43	TS-1026	93 - 0002	SPACER TUBE 3/8" O.D. x 4-1/4" S/S	1
44	TS-30247	93 - 0076	DIVERTER - BOTTOM	1
45	TS-30248	93 - 0077	DIVERTER - SIDES	1
46	TS-30249	93 - 0078	DIVERTER - TOP	1
47	TS-25130	93 - 0074	LEG 6" S/S - WITH ADJUSTABLE FOOT (TSCV-2)	1
48	TS-25131	93 - 0075	LEG PLATE ASSY. (TSCV-2)	1
49	TS-1030	93 - 0081	BURNER	1
50	TS-1097	93 - 0009	PILOT, 6S20-2 (NAT)	1
	TS-1025-26	93 - 0001	PILOT BELL ORIFICE - 3/16 CC #26 (NAT)	1
	TS-1631	93 - 0033	PILOT FERRULE 3/16 CC	1
	TS-1637	93 - 0035	PILOT NUT 3/16 CC	1
	TS-1098	93 - 0010	PILOT, 6S20-2 (LP)	1
	TS-1025-16	93 - 0000	PILOT BELL ORIFICE - 3/16 CC #16 (LP)	1
	TS-1631	93 - 0033	PILOT FERRULE 3/16 CC	1
TS-1637	93 - 0035	PILOT NUT 3/16 CC	1	
51	TS-22298	93 - 0068	FRONT BAFFLE - OVEN	1
52	TS-2041	93 - 0048	RACK GUIDE - R/H	1
	TS-2043	93 - 0050	RACK GUIDE - L/H	1
53	TS-2042	93 - 0049	RACK	1
54	TS-22321	93 - 0069	TOP PANEL	1
55	TS-22050	93 - 0051	FLUE EXTENSION (DOUBLE STACK)	1
56	TS-20131	93 - 0047	LEG ASSY. (SINGLE UNIT)	1
57	TS-1045	93 - 0003	FOOT	1
58	TS-23141	93 - 0072	BOTTOM LEG FRAME - SIDES	1
59	TS-23142	93 - 0073	BOTTOM LEG FRAME - FRONT & REAR	1
60	TS-1061	93 - 0007	CASTER W/BRAKE (FRONT)	2
61	TS-1060	93 - 0006	CASTER W/O BRAKE (REAR)	2