



33615 - 1/2" Pre-Rinse Sprayer - 33615

## Application

The overhead spray assembly is used for rinsing or spraying water in directions controlled by hand operation of the spray nozzle. Dual hand knobs allow manual selection of hot and cold water mixtures.

## Standard Specifications

### Spray Assembly:

- Dual water control valves with built in check valves for cross flow prevention.
- Four arm kitchen handles with color coded indexes.
- 44" Flexible hose.
- Spring support for easy control.
- Finger hook to hold the spray nozzle at the back of the sink.

### Mounting and Connection:

- 8" Center to Center vertical backsplash mount through 1-1/4" diameter holes.
- 1/2" NPT x 1/2" Sweat fitting.
- 3/8" NPT x 18" Tall riser.
- 12" Wall bracket for riser support.

### Operational:

- Spray nozzle 1.48 GPM

### Warranty:

- One year on parts from date of shipping.

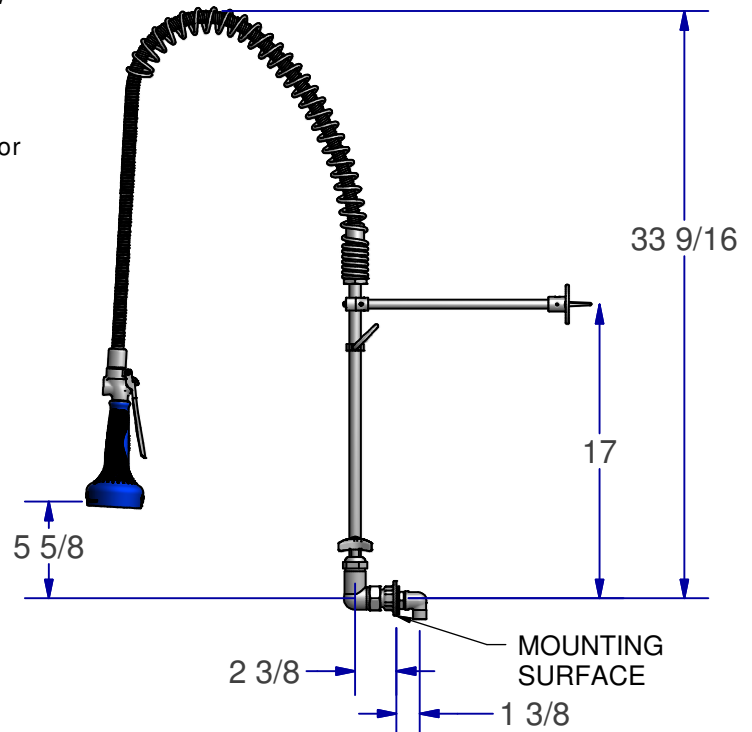

### 33615 Parts List

ITEM	QTY	PART NUMBER	DESCRIPTION
1	1	34266	1/2" Universal Seal Kit
2	2	34087	4-Arm Handle Kit
3	1	34274	1/2" Faucet Body with Valves
4	2	34259	1/2" Coupling Nut
5	2	34275	1/2" Elbow Assembly
6	2	34271	1/2" Spindle Assembly, with Check Valve (RH)
7	1	34276	1/2" Riser Assembly
8	1	33739	Overhead Spring
9	1	33738	44" Flex Hose
10	1	33736	1.48 GPM Sprayer Assembly
11	1	33746	12" Wall Anchor Assembly
12	1	33745	Spring Body

