

OVEN WIRING

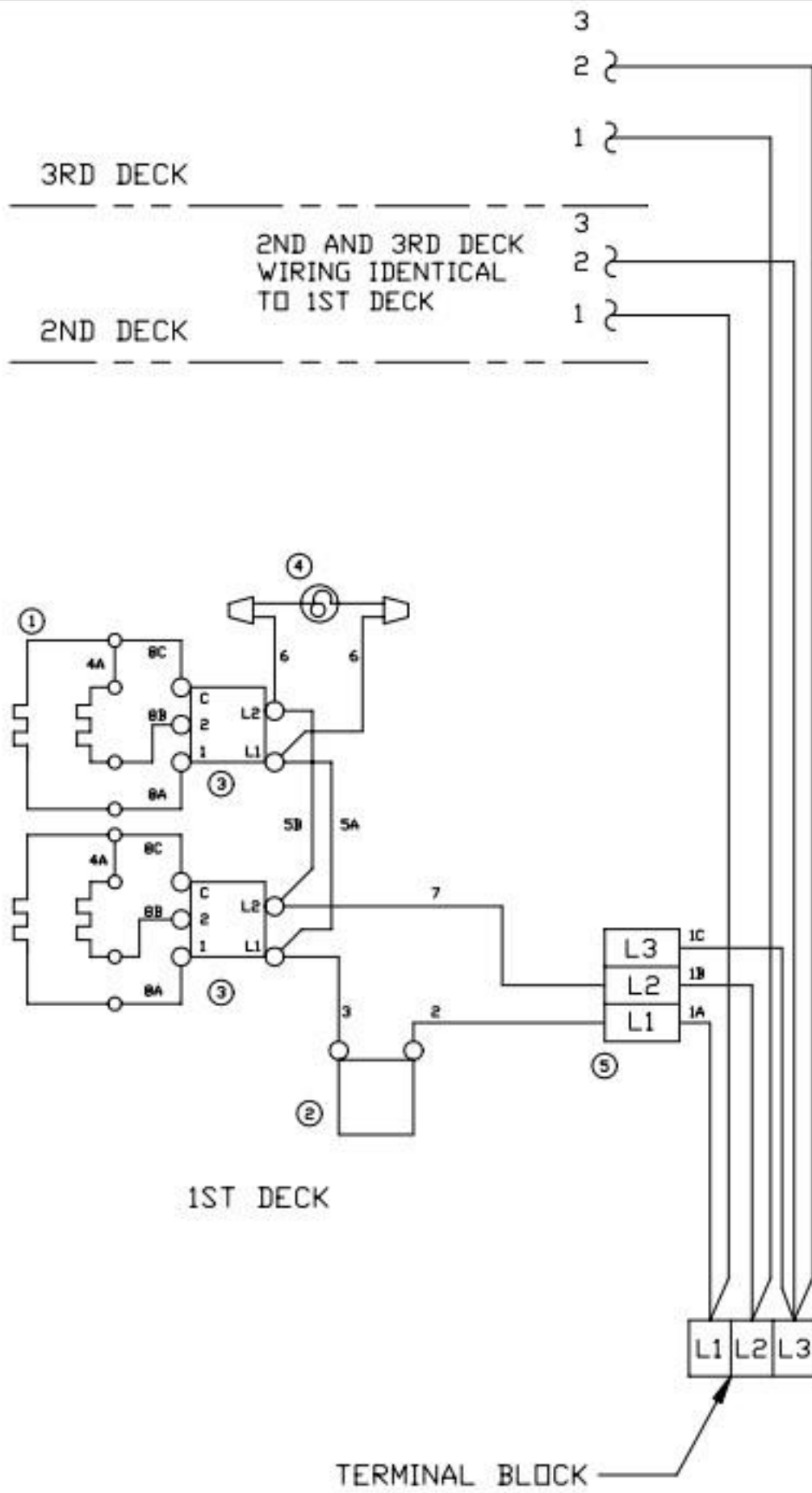

2ND AND 3RD DECK
WIRING IDENTICAL
TO 1ST DECK

1ST DECK

TERMINAL BLOCK

MODEL DESIGNATION

TOP ARRANGEMENT
SEC-1 SEC-2 SEC-3

36S-0	A	A	C
36S-2	B	B	B
36S-3A	B	B	C
36S-10	A	A	A
36S-20	C	C	C

- ① HEAT ELEMENT
- ② THERMOSTAT
- ③ 3 HEAT SWITCH
- ④ PILOT LAMP
- ⑤ CIRCUIT BREAKER
- ⑥ SPEED UNITS
- ⑦ 6 HEAT SWITCH

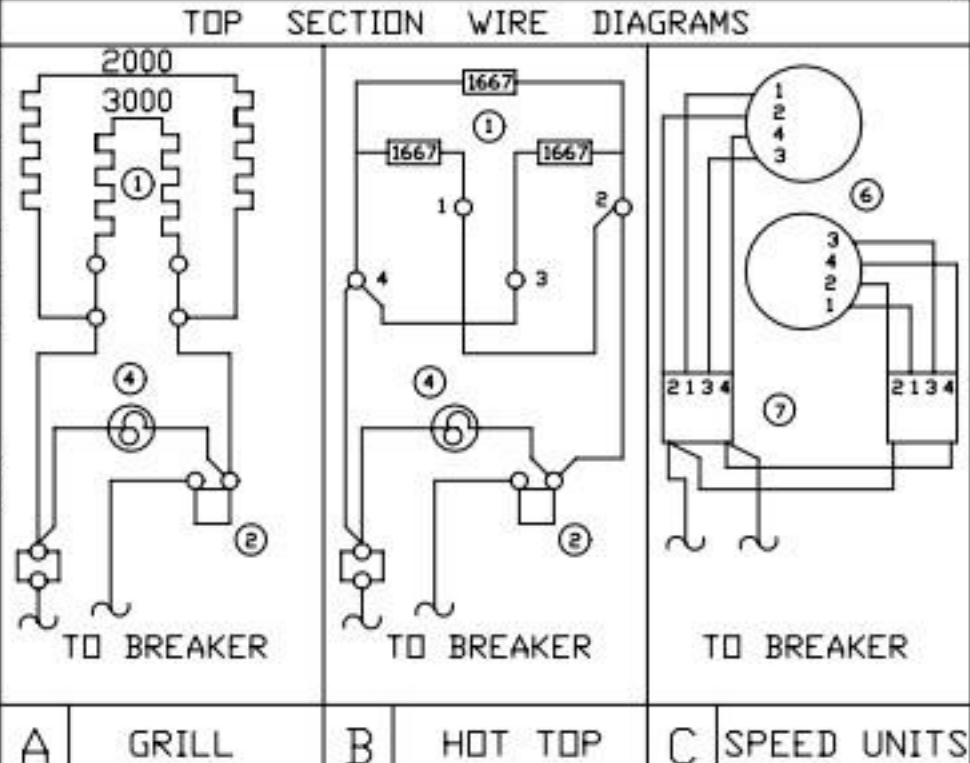
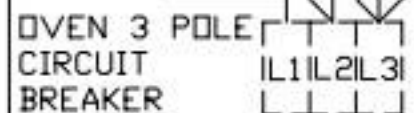

A GRILL B HOT TOP C SPEED UNITS

ELECTRICAL CONNECTIONS

CONNECT WIRES FROM RANGE TOP TO OVEN CIRCUIT BREAKER. CONNECT WIRES FROM ADDITIONAL DECKS TO LOWER OVEN TERMINAL BLOCK

POWER SUPPLY	RANGE TOP CONNECT TO OVEN CIRCUIT BREAKER	UPPER OVENS CONNECT TO BOTTOM DECK TERMINAL BLOCK		
		1st DECK	2nd DECK	3rd DECK
THREE PHASE	L1	3	1	1
	L2	1-5	2	1
	L3	2-4-6	-	2

ELECTRICAL DATA

MODEL NUMBER	LOADING					KW TOTAL	AMPS 480 VOLT		
	KW PER PHASE						L1	L2	L3
	L1	L2	L2	L3	L3				
36S RANGE	6.0	10.0	5.0	21.0	19.9	28.9	27.1		
LA-136 OVEN	6.0	0.0	0.0	6.0	12.5	12.5	0.0		
LA-236S *	6.0	0.0	6.0	12.0	21.7	12.5	12.5		
LA-336S *	6.0	6.0	6.0	18.0	21.7	21.7	21.7		

USE ON ALL E SERIAL NUMBERS

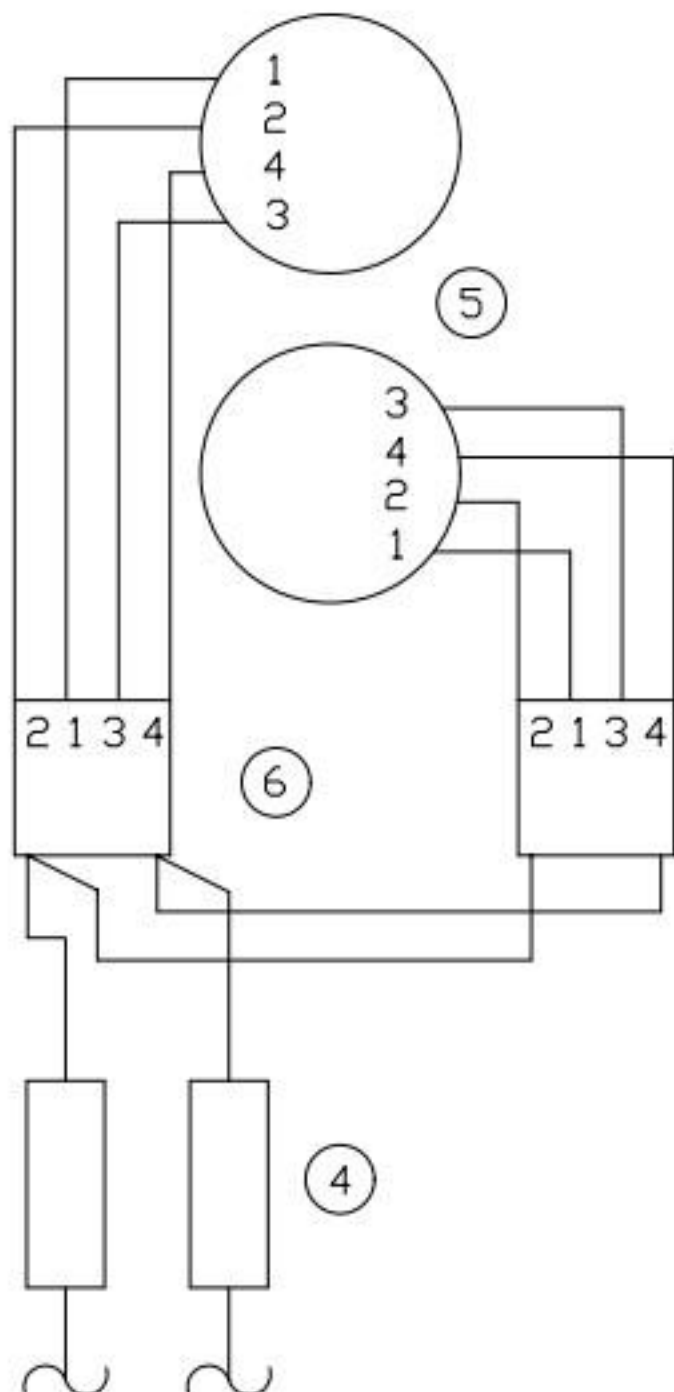

C

SPEED UNITS

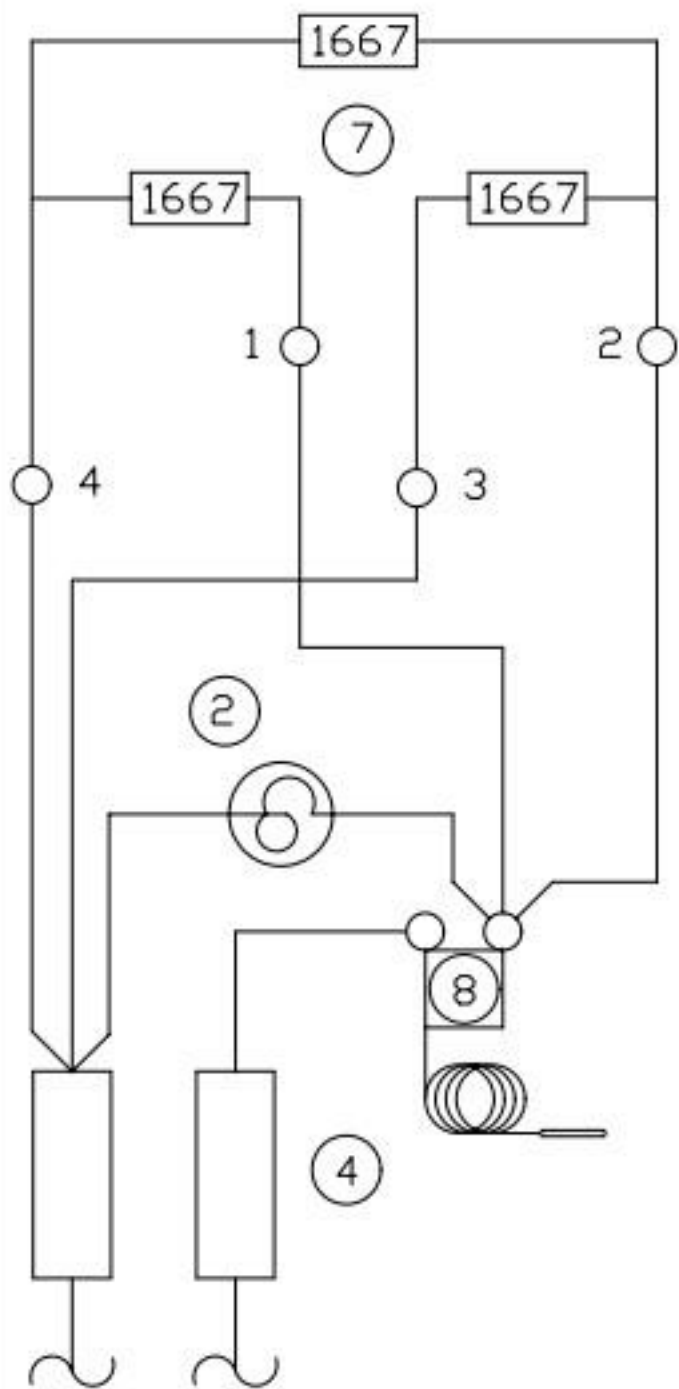

B

HOT TOP

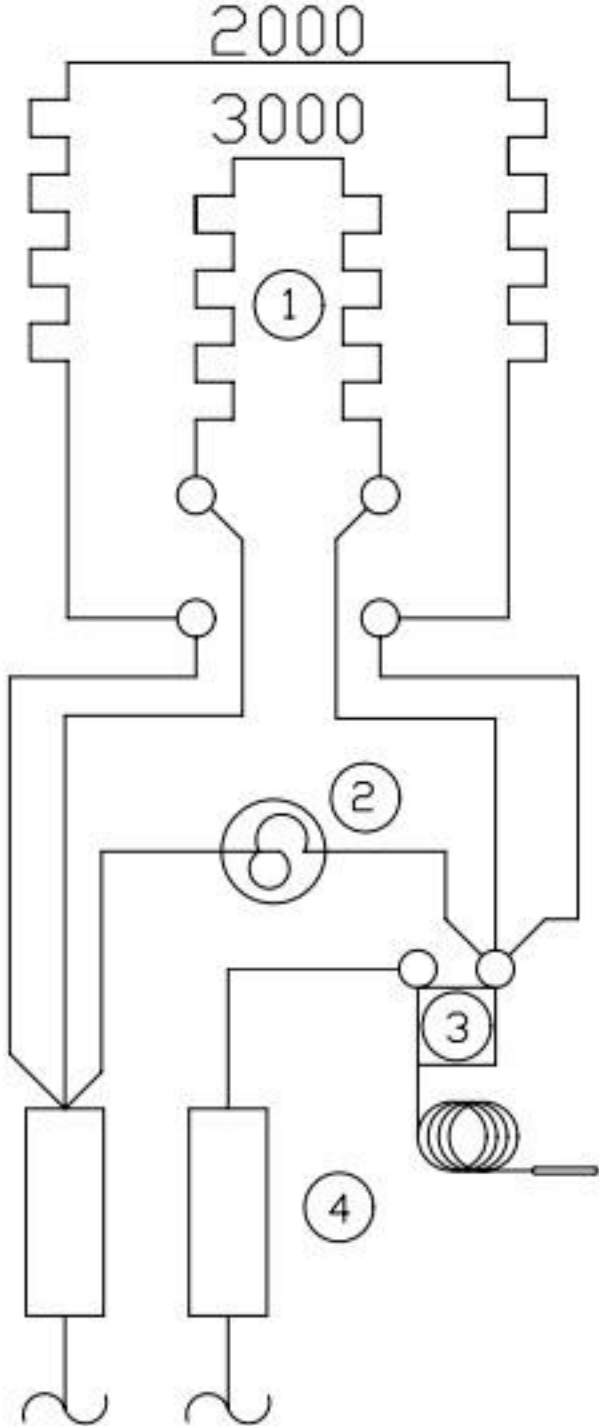

A

GRILL

OVEN WIRING

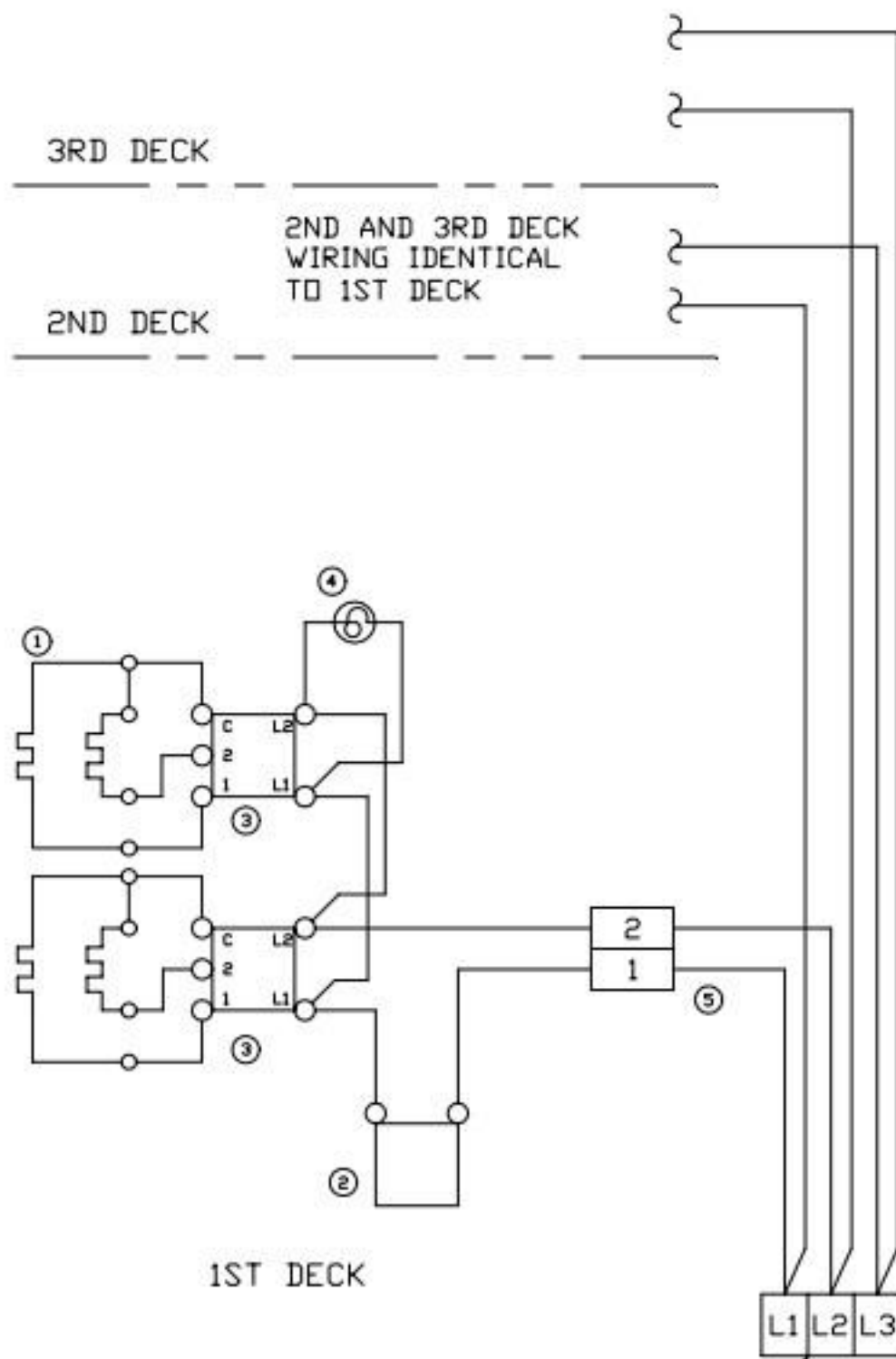

MODEL DESIGNATION	TOP ARRANGEMENT			TOP SECTION WIRE DIAGRAMS		
	SEC-1	SEC-2	SEC-3	A	B	C
36S-0	A	A	C			
36S-2	B	B	B			
36S-3A	B	B	C			
36S-10	A	A	A			
36S-20	C	C	C			
① HEAT ELEMENT ② THERMOSTAT ③ 3 HEAT SWITCH ④ PILOT LAMP ⑤ CIRCUIT BREAKER ⑥ SPEED UNIT ⑦ 6 HEAT SWITCH						

CONNECT WIRES FROM RANGE TOP OR ADDITIONAL DECKS TO LOWER OVEN TERMINAL BLOCK AS SHOWN AT RIGHT

ELECTRICAL CONNECTIONS					
POWER SUPPLY	TERMINAL BLOCK	RANGE TOP	OVEN		
			1st DECK	2nd DECK	3rd DECK
SINGLE PHASE	L1	1-3-5	1	1	1
	L2	2-4-6	2	2	2
THREE PHASE	L1	3	1	1	-
	L2	1-5	2	-	1
	L3	2-4-6	-	2	2

MODEL NUMBER	LOADING					KW TOTAL	THREE PHASE AMPS						SINGLE PHASE AMPS		
	KW PER PHASE						208 VOLT			240 VOLT			208V		240V
	L1	L2	L2	L3	L3		L1	L1	L2	L3	L1	L2	L3		
36S RANGE	6.0		10.0		5.0	21.0	45.8	66.7	62.5	39.7	57.8	54.2	101.0	87.5	
LA-136S OVEN	6.0		0.0		0.0	6.0	28.8	28.8	0.0	25.0	25.0	0.0	28.8	25.0	
LA-236S	6.0		0.0		6.0	12.0	50.0	28.8	28.8	43.3	25.0	25.0	57.7	50.0	
LA-336S	6.0		6.0		6.0	18.0	50.0	50.0	50.0	43.3	43.3	43.3	86.5	75.0	

USE ON ALL E SERIAL NUMBERS