

**SOLID STATE DIGITAL TOASTER  
PRINCE CASTLE MODEL NO. 411-C SERIES**



This equipment chapter is to be placed in the toasters section of your *Equipment Manual*.

**MANUFACTURED FOR  
MCDONALD'S®  
BY  
PRINCE CASTLE INC.  
355 KEHOE BLVD.  
CAROL STREAM, IL. 60188 USA  
PHONE 1-630-462-8800  
TOLL FREE NUMBER  
1-800-323-2930  
FAX:1-630-462-1460**



WARRANTY .....	Page 1
SIDE VIEW .....	Page 2
FRONT VIEW .....	Page 3
REAR VIEW .....	Page 3
INTERNAL VIEW .....	Page 4
EQUIPMENT SET-UP .....	Page 5
PROGRAMMING .....	Page 6
CLEANING .....	Page 8
TROUBLESHOOTING .....	Page 8
DIAGNOSTIC TROUBLESHOOTING .....	Page 9-10
SPANISH TRANSLATION .....	Page 11-16
WIRING DIAGRAM .....	Page 17

**LIMITED WARRANTY**

This product is warranted to be free from defects in material and/or workmanship for a period of (2) years from date of original installation not to exceed 30 months from date of shipment from our factory. Printed circuit boards and platen are warranted for a period of (3) years from date of original installation not to exceed 42 months from date of shipment from our factory. Any part or component which proves to be faulty in material and/or workmanship within the warranty period will be replaced or repaired without cost to the customer for parts or labor. (At the option of Prince Castle, Inc.)

This warranty is subject to the following exceptions/conditions:

- Any use of Non-genuine Prince Castle spare parts voids this warranty, and all work must be performed by an authorized Prince Castle Service Agent.
- All labor should be performed during regular working hours. Overtime premium will not be covered.
- On location service is limited to 100 miles (200 km) round trip and 2 hours travel time, one trip per repair.
- Damage caused by carelessness, neglect, and/or abuse (e.g., using wrong current, dropping , tampering with or altering electrical components, or improper cleaning) is not covered.
- Equipment damaged in shipment, by fire, flood or an act of God.

This manual is for the exclusive use of licensees and employees of McDonald's Systems, Inc.

Printed in September

## SIDE VIEW

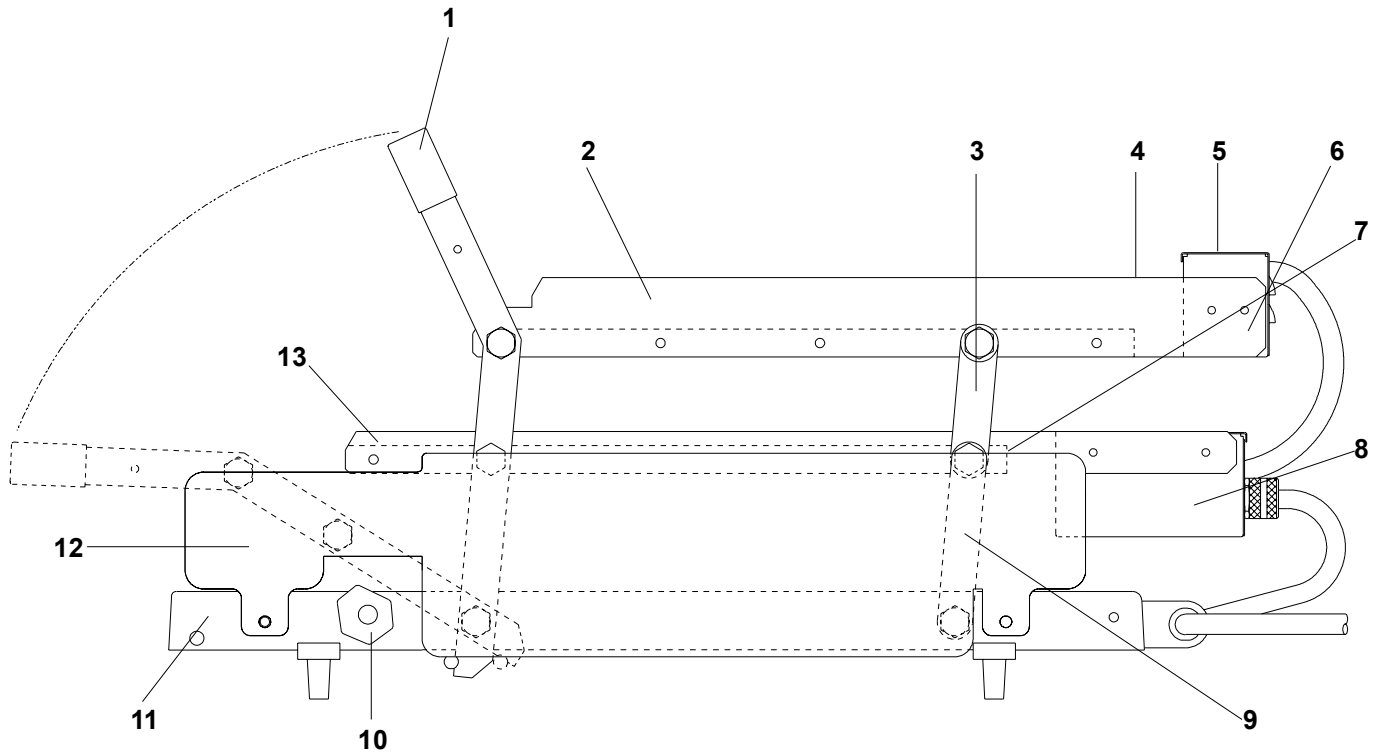

## PARTS LIST

ITEM	PART NUMBER	DESCRIPTION
1	411-149S	Handle and Lever Assy.
2	411-441	Right Hand Upper Bun Fence
	411-440	Left Hand Upper Bun Fence
3	411-461S	Upper Rear Lever Assy.
4	411-378	Upper Rear Bun Fence
5	411-31	Upper Cover
6	411-283	Upper Chassis
7	411-381	Lower Rear Bun Fence
8	411-741	Lower Chassis
9	411-459S	Lower Rear Lever Assy.
10	411-137	Right Hand Stop Block
	411-138	Left Hand Stop Block
11	411-2S	Base
12	411-444	Side Panel, Right Hand
	411-445	Side Panel, Left Hand
13	411-379	Right Hand Lower Bun Fence
	411-380	Left Hand Lower Bun Fence
Not Shown	411-114	Safety Latch
Not Shown	411-131	Bun Board
Not Shown	411-245S	Sensing Strip (On Cover Of Lower Control Box)

## FRONT VIEW

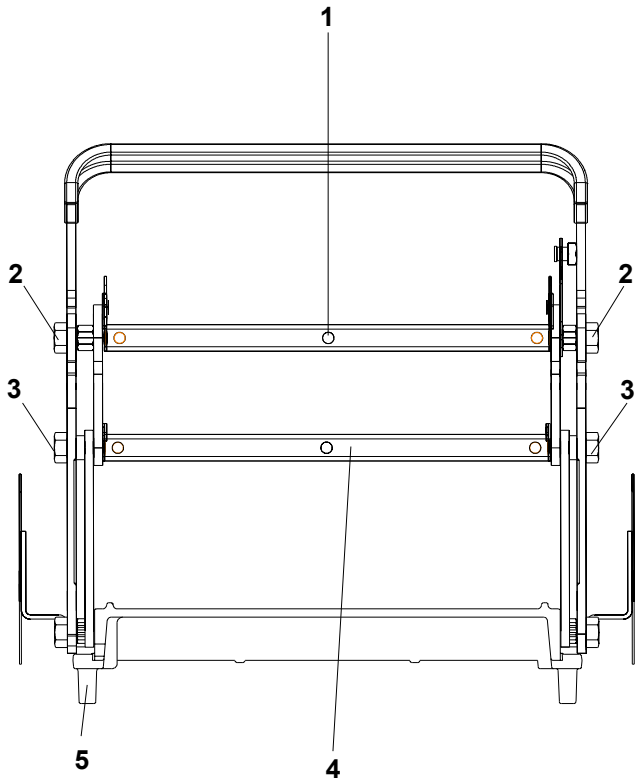

## PARTS LIST

ITEM	PART NUMBER	DESCRIPTION
1	411-6S	Upper Platen 120V
	411-18S	Upper Platen 200V
	411-483S	Upper Platen 220V
2	411-60	Front Upper Platen Stud
	411-60	Front Lower Platen Stud
4	411-8S	Lower Platen 120V
	411-20S	Lower Platen 200V
	411-486S	Lower Platen 220V
5	89-959S	Foot (Pkg. of 4)

## REAR VIEW

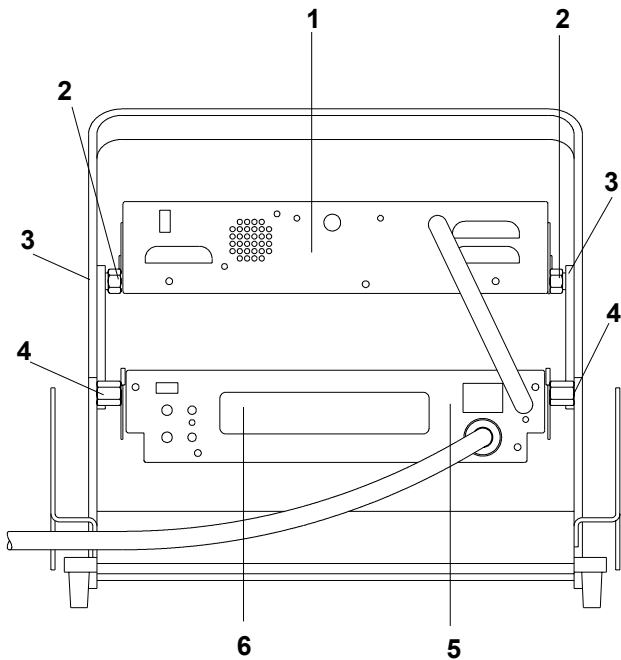

## PARTS LIST

ITEM	PART NUMBER	DESCRIPTION
1	411-712	Upper Faceplate
2	411-57	Platen Spacer
3	411-147	Rear Upper Platen Stud
	411-61	Rear Lower Platen Stud
5	411-705	Lower Faceplate
6	411-707	Overlay

## INTERNAL VIEW UPPER CONTROL BOX

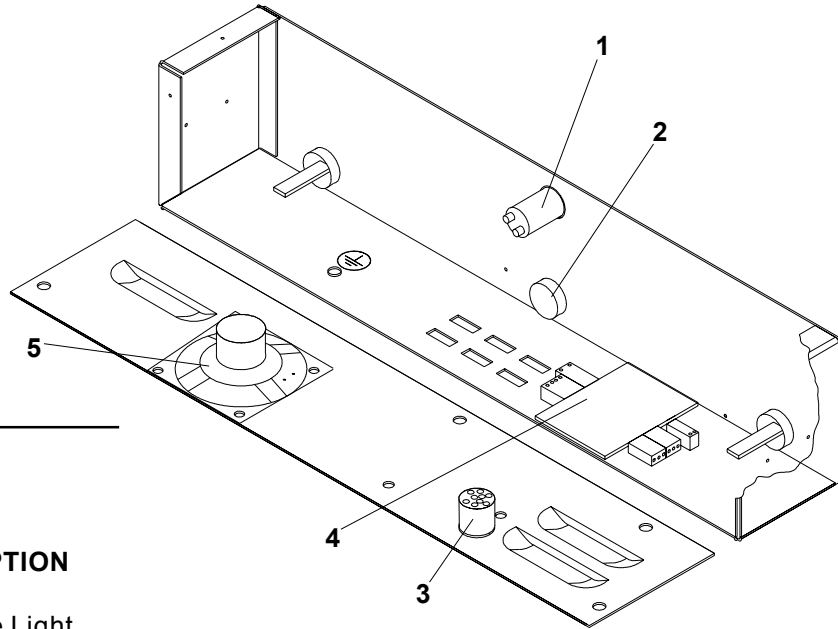

### PARTS LIST

ITEM	PART NUMBER	DESCRIPTION
1	213-257S	Bun Done Light
2	411-700S	Upper Probe
3	411-740	Interconnect Cable
4	411-14S	Interconnect Board
5	213-229S	Speaker

## INTERNAL VIEW LOWER CONTROL BOX

### PARTS LIST

ITEM	PART NUMBER	DESCRIPTION
1	65-053-04S	Relay
2	411-700S	Probe
3	72-301S	Power Cord Only (220-230V)
	72-273S	Power Cord w/Twist Lock Plug(120/208)
4	78-166S	Rocker Switch
5	411-426S	Control Display
	411-427-02S	P.C. Board, 120V
		Control Display
		P.C. Board, 200-230V

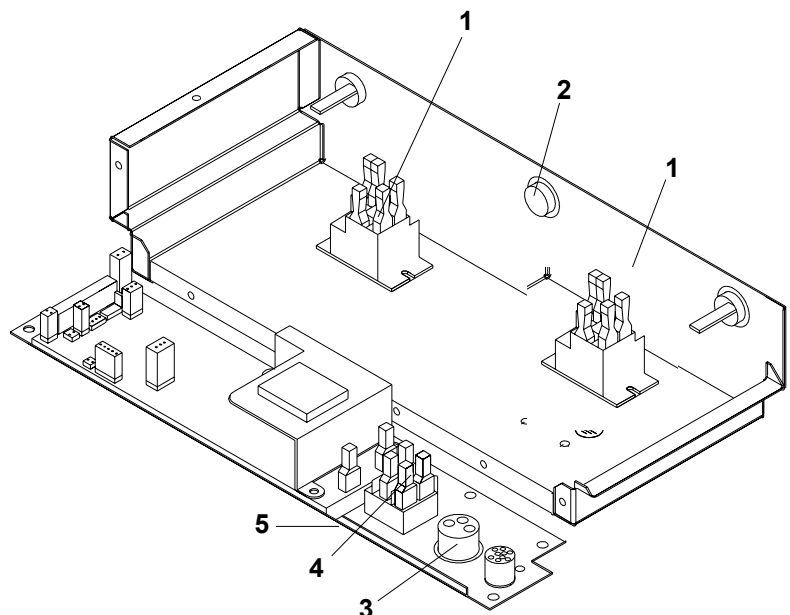

## SYMBOLS & TERMS

**C -- A** Toaster is set on Celsius.

**F -- A** Toaster is set on Fahrenheit.

**A L -** Alarm Level setting 1-4.



Sound Button: Used with timer button and temperature button to set alarm level.



Timer Button: Used to view time in run mode. Used to set time in program mode.



Temperature Button: Used to view set point temperature in run mode, and used to set the set point temperature in program mode.



Up Arrow: Used to set time, sound and temperature in program mode.



Down Arrow: Used to set time, sound, and temperature in program mode.

## FACTORY PRE-SET

Prince Castle's Solid State Digital Display toasters are pre-set at the factory.

If your toaster model is set for a 35 second toast time, then the temperature is pre-set and calibrated to 215°C.

If your toaster model is set for a 55 second toast time, then the temperature is pre-set and calibrated to 204°C.

## SET-UP

1. Refer to the nameplate on the control box for the proper operating voltage. Connect the toaster to a grounded receptacle that matches the nameplate voltage information. Press the power switch to the on position, allow the unit 30 minutes to reach operating temperature.
2. The toaster is factory-set to display temperatures reading in Celsius. When the toaster is turned on, the digital display on the control box will read C--A for Celsius, and the "A" will begin to count down 9 seconds. During this countdown, you can change the temperature display from Celsius to Fahrenheit readings. To change temperature display, press and hold the temperature button for six seconds. See figure 1.

figure 1

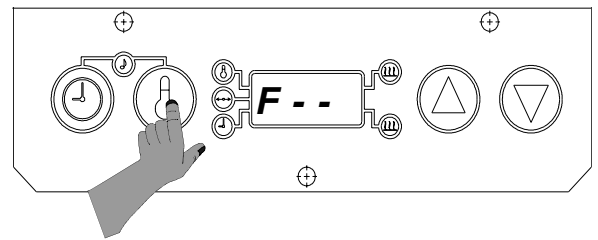

3. During the pre-heat cycle, the display will read -L O-. When the platen temperature reaches 149° C (300° F), the display will begin to show the actual platen temperatures throughout the toasting cycles. See figure 2.

figure 2

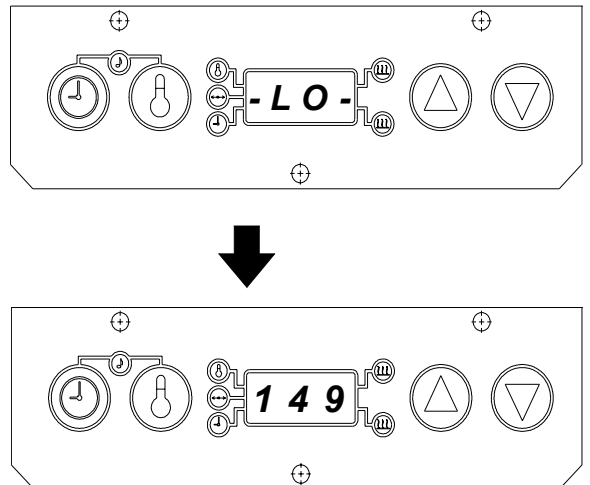

### Sound Level Adjustment



The audio alarm has four sound levels.

1. Press and hold the time button and temperature buttons simultaneously. The display will show the current sound level. The toasters are factory set at level 4, and the display will read, **A L 4** for Alarm Level 4. See figure 3.

figure 3

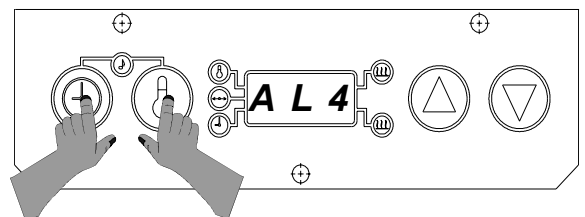

- While holding the time and temperature buttons, press the up or down arrow buttons to adjust the sound level. A continuous tone will sound. Release all buttons when the desired sound level is reached. The display will show the current sound level. See figure 4.

figure 4

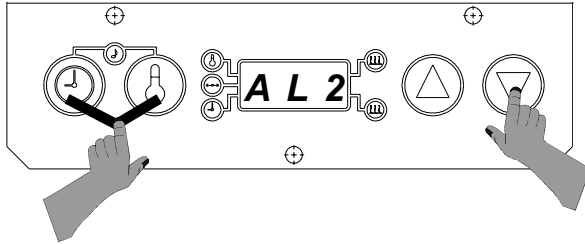

### VIEW SET POINT TEMPERATURE

- Press and release the temperature button. (Do not hold for more than 6 seconds.) A beep will sound, the temperature indicator will turn on, and the display will show the set point temperature for three seconds. The display will then change to show the actual temperature. See figure 5.

figure 5

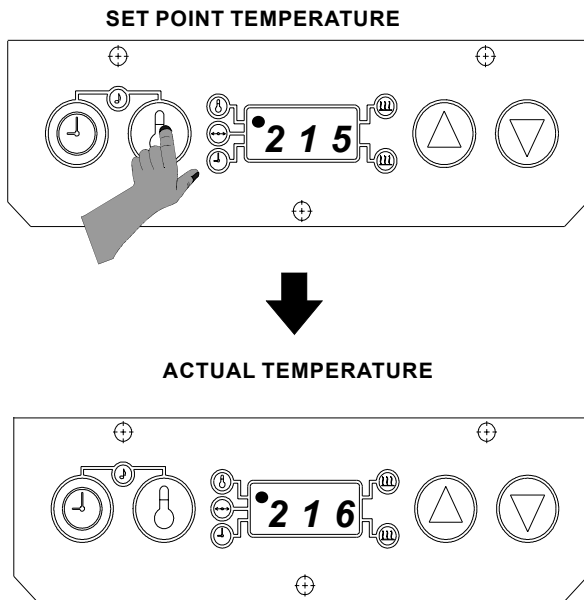

### VIEW TIMER SETTING

- Press and release the time button. (Do not press the time button for more than 6 seconds.) The set time will be displayed for three seconds. If the timer is activated and is in a countdown sequence, the time remaining will be displayed, and will continue to countdown to zero. After three seconds, the display will change to show actual platen temperature. See figure 6.

figure 6

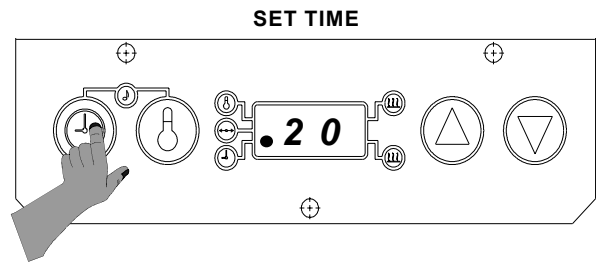

## PROGRAMMING

The programming modes are used for setting individual set point temperature, and setting toast times.

### Programming the Set Point Temperature

- Press and hold the temperature button for six seconds to change both platen temperatures. Press and hold Temperature button and up arrow for upper platen. Press and hold temperature button and down arrow for lower platen. See figure 7.

figure 7

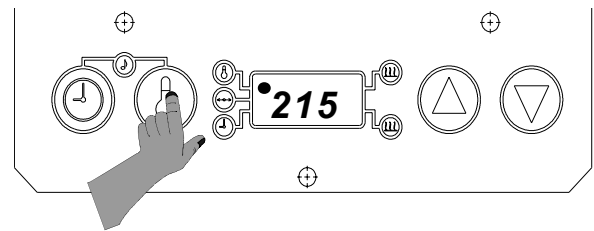

- To change the set point temperature, use the up or down arrow. Once the desired temperature is displayed, press the temperature button to store the new setting. See figure 8.

figure 8

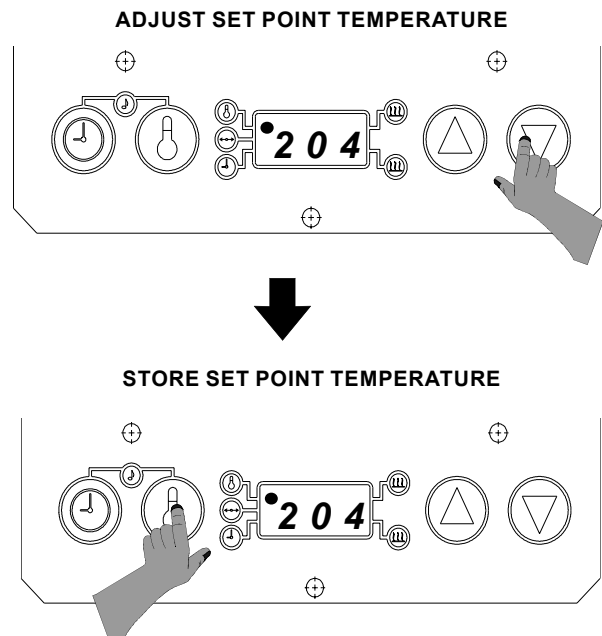

- To cancel the set point programming mode at any time, press and release the time button. The display will change to show the actual platen temperature. See figure 9.

figure 9

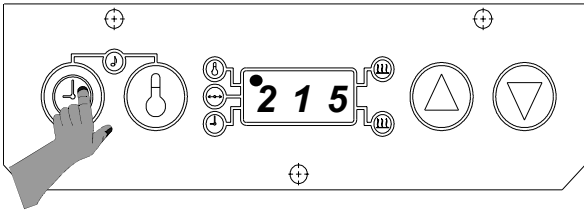

- To cancel the time set function at any time, press and release the temperature button. The time indicator light will turn off, and the display will change to show the actual platen temperature. See figure 12.

figure 12

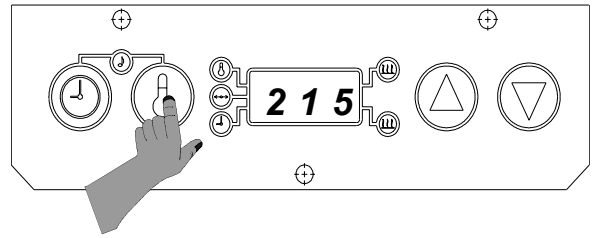

### Programming Toast Times

- Press and hold the time button for 6 seconds. A beep will sound, and the time indicator light will blink. Release the time button to show the current toast time. See figure 10.

figure 10

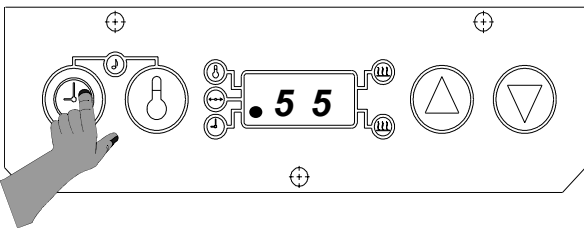

- Use the up and down arrow buttons to set your desired toast time. The range is from 20 seconds to 1 minute, 30 seconds. When desired time is reached, press and release the time button to store the new time. See figure 11.

figure 11

#### SETTING THE NEW TIME

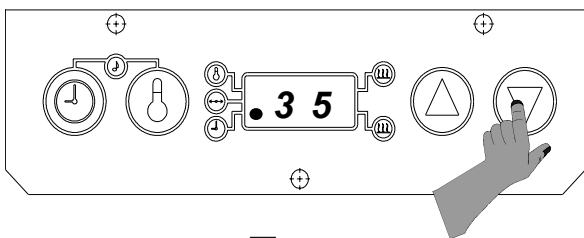

#### STORING THE NEW TIME

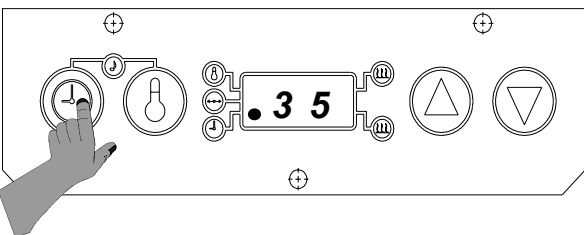

### SETTING STOP BLOCKS

Stop blocks allow for proper crush when toasting buns. The toaster leaves the factory with the stop blocks set on R/Q.

Dual stop blocks allow you to switch back and forth from Reg/Qtr. bun and Big Mac Bun toasting, or Rib bun or Rye bun toasting.

- Ensure the stop blocks are on the correct setting. There are (6) combination Stop Block Settings:

- |                 |                 |
|-----------------|-----------------|
| 1. R/Q / MAC    | 4. RIB / RYE    |
| 2. R/Q+ / MAC + | 5. RIB+ / RYE + |
| 3. R/Q- / MAC - | 6. RIB- / RYE - |

THE (+) SETTING IS FOR BUNS THAT ARE CUT TOO THICK. THE (-) SETTING IS FOR BUNS CUT TOO THIN. FOR NORMAL SIZE BUNS DO NOT USE (+) or (-) SETTINGS.

[R/Q = REG/QTR]

- Rotate stop blocks by hand to the desired combination bun setting listed above.
- View the stop block setting selected through the index window bracket, which is located over the left stop block. See figure 13.

figure 13

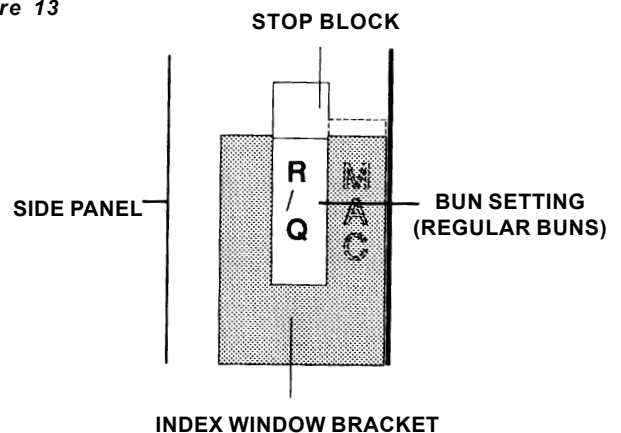

- To switch between the two types of buns per your stop block setting, locate the selector lever on the front of the toaster frame. Move the lever left or right to switch back and forth between the combination setting. See figure 14.

figure 14

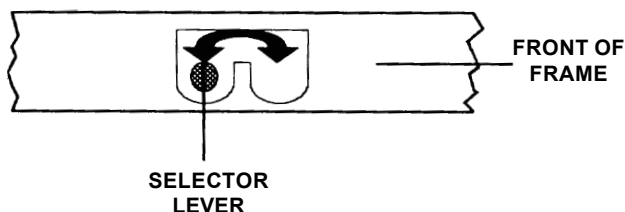
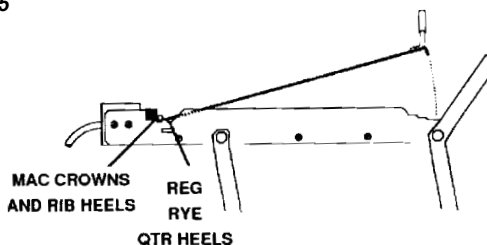

figure 15



### BUN BOARD ADJUSTMENTS

- Push or pull the bun board handle to desired notched setting as indicated by graphics stamped on top of bun board. See figure 15.
- Bun board graphics are:  
 FRONT = REG, RYE, QTR HEELS  
 REAR = BIG MAC, (CROWNS) AND RIB HEELS

## CLEANING

- Press the power switch to the off position.
- Unplug toaster.
- Allow toaster and platens to cool down.
- Wipe entire platen with clean, damp grill cloth. Full toaster cleaning must be done in the morning when toaster is cold. See your *Planned Maintenance Card* for proper cleaning procedures.

**IMPORTANT:** Do not drape cord over hot toaster bun board or platen. This will cause cord to burn.

## TROUBLESHOOTING GUIDE

PROBLEM	CAUSE	SOLUTION
Platen loose.	Platen bolts loose.	Tighten platen bolts.
Speaker sounds, but no bun done light comes on.	Done light burned out.	Replace done light.
No audio alarm or amber colored bun "done" light.	Interconnect cable connection loose. Keyhole slot filled with debris. Speaker defective Opto-Sensor board defective	Check connections at Opto-Sensor board and main board. Clean keyhole slot. Replace speaker. Replace Opto-Sensor board.
Buns being crushed.	Stop blocks not adjusted properly. Warped bun trays.  Buns cut improperly.	Adjust stop blocks.  Straighten or replace bun trays. Contact bakery.
Platen does not heat.	No power. Power switch defective. Shorted power board. Platen burned out or shorted.	Check power source. Replace power switch. Replace power board. Check platen with ohmmeter for 11 ohms, if reading is less than 7 ohms or more than 14 ohms, replace platen.
No Display.	Fuse Defective.	Check fuse with ohmmeter, reading should be 1-2 ohms.

# DIAGNOSTIC TROUBLESHOOTING

If the toaster malfunctions, the display will flash an error code **E** and a number between **1-9**, or a letter between **A-E**. Below are different error codes and their solutions. For Example If error code is **EO1**, a failure related to the lower platen controls has occurred. If error code is **E10** a failure related to the upper platen controls has occurred.

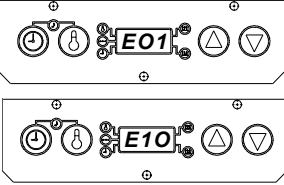
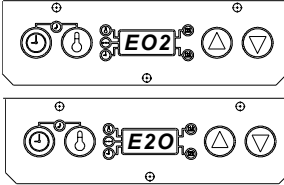
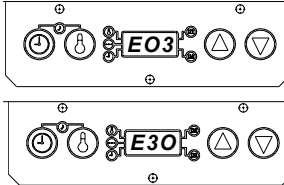
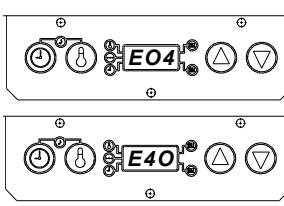
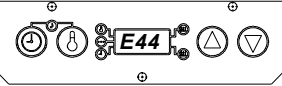
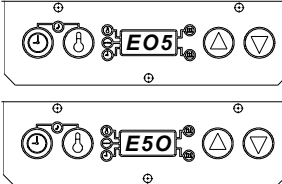
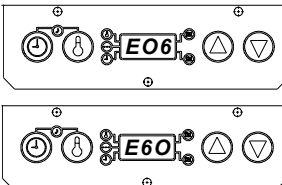
Diagnostics	Problem	Solution
	<p>1. Lower Relay Contacts Shorted. Lower Platen Overheating.</p> <p>1. Upper Relay Contacts Shorted. Upper Platen Overheating.</p>	<p>Replace Lower Relay. Replace P. C. Board.</p> <p>Replace Upper Relay. Replace P. C. Board.</p>
	<p>2. Lower Probe Open.</p> <p>2. Upper Probe Open</p>	<p>Replace Lower Probe.</p> <p>Replace Upper Probe.</p>
	<p>3. Lower Failures 1 And 2 Combined</p> <p>3. Upper Failures 1 And 2 Combined</p>	
	<p>4. Lower Platen Underheating.</p> <p>4. Upper Platen Underheating.</p>	<p>Replace Lower Relay. Check Lower Platen Resistance. Replace P. C. Board.</p> <p>Replace Upper Relay Check Upper Platen Resistance. Replace P. C. Board.</p>
	<p>Both Platens Underheating.</p> <p>2. A maximum of 900 sets of buns can be toasted in 1 hour, anything over that and the toaster can go into an E44 failure. If this happens discontinue using the toaster for 3 minutes and the failure will clear. You can then resume using the toaster again. If None of the above occurs, replace the P. C. Board.</p>	<p>1. Check For Cool Air Blowing On Toaster.</p>
	<p>5. Lower Failures 1 And 4 Combined.</p> <p>5. Upper Failures 1 And 4 Combined.</p>	
	<p>6. Lower Failures 2 And 4 Combined.</p> <p>6. Upper Failures 2 And 4 Combined.</p>	

 	<p>7. Lower Failures 1, 2 And 4 Combined.</p> <p>7. Upper Failures 1, 2 And 4 Combined.</p>	
 	<p>8. Lower Probe Circuit Failure.</p> <p>8. Upper Probe Circuit Failure.</p>	<p>Replace P. C. Board.</p> <p>Replace P. C. Board.</p>
 	<p>9. Lower Failures 1 And 8 Combined.</p> <p>9. Upper Failures 1 And 8 Combined.</p>	
 	<p>10. Lower Failures 2 And 8 Combined.</p> <p>10. Upper Failures 2 And 8 Combined.</p>	
 	<p>11. Lower Failures 1, 2 And 8 Combined.</p> <p>11. Upper Failures 1, 2 And 8 Combined.</p>	
 	<p>12. Lower Failures 4 And 8 Combined.</p> <p>12. Upper Failures 4 And 8 Combined.</p>	
 	<p>13. Lower Failures 1, 4 And 8 Combined.</p> <p>13. Upper Failures 1, 4 And 8 Combined.</p>	
 	<p>14. Lower Failures 2, 4 And 8 Combined.</p> <p>14. Upper Failures 2, 4 And 8 Combined.</p>	

