

OPERATING INSTRUCTIONS

MODEL NO. 965-SPM SPAM SLICER



Limited Warranty

This product is warranted to be free from defects in material and/or workmanship at the time of delivery only. **A Proof of Purchase is required for all warranty claims.**



Note: Although the cutting bars are not sharp, please keep fingers and foreign objects away from cutting bars to prevent injury or damage to slicer.

Installation

1. After you have removed the Spam Slicer from the carton, inspect the unit for signs of damage. If there is damage to the unit:
 - Notify carrier within 24 hours after delivery.
 - Save carton and packing materials for inspection purposes.
 - Contact the Prince Castle Customer Sales Department at 1-630-462-8800 to arrange for a replacement to be sent.
2. Verify that all parts have been received.



Caution: Pieces of Spam left on cutting bars or slotted platform may cause tearing of spam or damage to the slicer. Inspect the slicer after **each** use.

Cleaning

Regularly throughout the day and at closing, thoroughly clean and sanitize the Spam Slicer.

Operation

1. Use only boneless meat products.
2. Place Spam on slotted platform.
3. Lay cutting bars on top of Spam and press down firmly.
4. Use spatula to remove sliced Spam from frame and lift cutting bars to repeat process.
5. Use nylon brush (Prince Castle part no. 943-042) to remove any pieces of Spam left on cutting bars or slotted platform.

1. Remove the hinge pin to release the cutting bars and slotted platform.
2. Spray the slicer parts with hot water to loosen Spam residue.
3. Brush the cutting bars and slotted platform with a nylon cleaning brush.
4. Wash the Spam slicer in cleaning solution, hot soapy water, or a dishwasher.
5. Rinse by spraying the slicer with hot water.
6. Soak/rinse the Spam slicer with sanitizer.
7. Allow to air dry.

PRINCE CASTLE INC. 
WORLDWIDE



A Marmon Retail Services[®] Company

355 E. Kehoe Blvd. • Carol Stream, IL 60188
Tel: (630) 462-8800 • Fax (630) 462-1460
Toll Free: 1-800-323-2930

Parts Identification

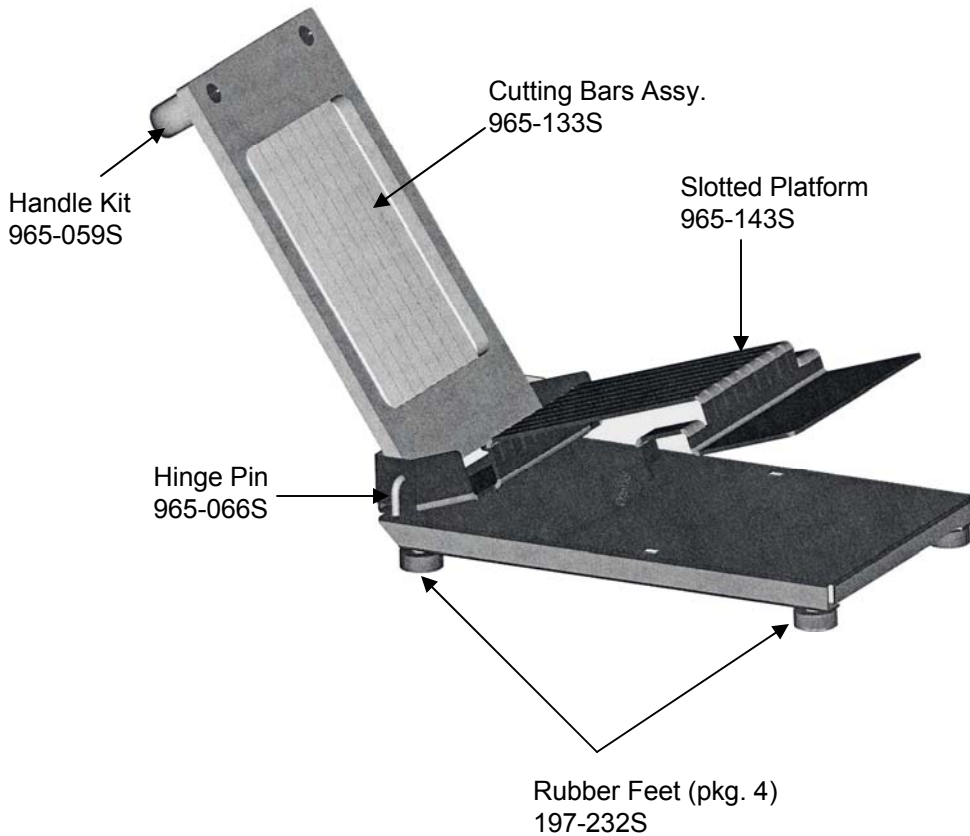

Troubleshooting	
Difficulty in cutting	1. Make sure cutting bars and slotted platform are cleared of any Spam pieces.
	2. Inspect cutting bars. Replace if bars are bent, twisted, or broken.
	3. Inspect slotted platform. Straighten or replace if bent.



FFF A Marmon Retail Services Company

355 E. Kehoe Blvd. • Carol Stream, IL 60188
 Tel: (630) 462-8800 • Fax (630) 462-1460
 Toll Free: 1-800-323-2930