

## Installation/Operation Manual/Parts Manual

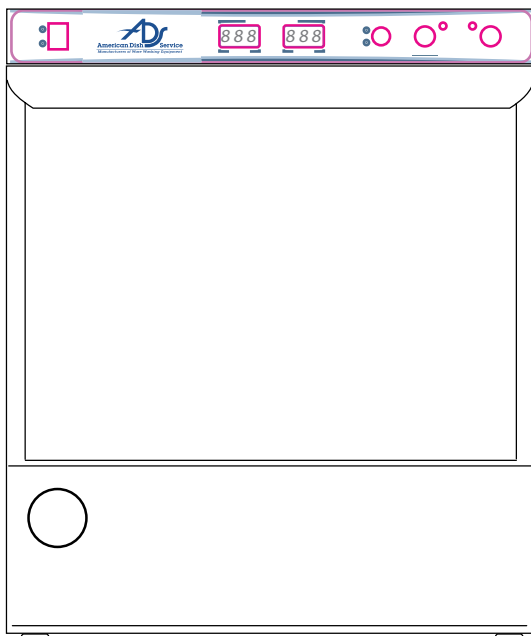

### Undercounter Dishwashers ADS HUB-40-HIGH TEMP

High Temperature  
with built-in booster  
Fresh Water Final Rinse

THE MODELS CONTAINED IN THIS  
MANUAL COMPLY WITH ANSI/ASSE  
1001 & ANSI/ASSE 1004.



[www.americandish.com](http://www.americandish.com)

Issue Date: 8.17.22

**Manual P/N**      **A0513316 Rev.A**

For machines beginning with S/N W2204106955 and above

For future reference, record your dishwasher information in the box below.

Model Number _____	Serial Number _____
Voltage _____ Hertz _____	Phase _____
Service Agent _____	Tel: _____
Parts Distributor _____	Tel: _____

National Service Department  
In the USA:  
Toll-free: 800-922-2178  
Tel: 913-422-3700  
Fax: 913-422-6630  
email: [service@americandish.com](mailto:service@americandish.com)

**ATTENTION:**

The model no., serial no., voltage, Hz and phase are needed to identify your machine and to answer questions.

The machine data plate is located on the lower front panel.

Please have this information ready if you call for service assistance.



*The USGBC Member Logo is a trademark owned by the U.S. Green Building Council and is used by permission. The logo USGBC does not review, certify or endorse the products or services offered by its members.*



- Use the fax form on the next page.



# PRODUCT REGISTRATION BY FAX

**COMPLETE THIS FORM AND FAX TO:**

**913-422-6630 in the USA**

## PRODUCT REGISTRATION CARD

Model	Serial #
-------	----------

Date of Installation: \_\_\_/\_\_\_/\_\_\_

Company Name: \_\_\_\_\_

Address: \_\_\_\_\_ (Street) \_\_\_\_\_ Province \_\_\_\_\_ Postal Code

Telephone #: ( ) \_\_\_\_\_ --- \_\_\_\_\_

Contact: \_\_\_\_\_

Installation Company: \_\_\_\_\_

Address: \_\_\_\_\_

Telephone #: \_\_\_\_\_

Contact: \_\_\_\_\_

**FAILURE TO REGISTER YOUR PRODUCT MAY VOID YOUR WARRANTY**

**IMPORTANT IMPORTANT**

## Revision History

A revision might be a part number change, a new instruction, or other information that was not available at print time. We reserve the right to make changes to these instructions without notice and without incurring any liability by making the changes. Equipment owners may request a revised manual, at no charge, by calling 1 (800) 922-2178 in the USA.

Revision Date	Revised Pages	Serial Number Effectivity	Revision Description
27.06.22	All	W2204106955	Released First Edition

## Limited Warranty

### LIMITED WARRANTY

American Dish Service (herein referred to as ADS), 300 Blake Street, Edwardsville, KS 66111-3820 U.S.A. warrants machines, and parts, as set out below.

**Warranty of Machines:** ADS warrants all new machines of its manufacture bearing the name "ADS" and installed within the United States, Islands, Mexico and Canada to be free from defects in material and workmanship for a period of one (1) year after the date of installation or fifteen (15) months after the date of shipment by ADS, whichever occurs first. [See below for special provisions relating to glasswashers.]

Warranty registration must be submitted to ADS within ten (10) days after installation in the USA Via email, USPS .

or by fax on the form provided at the front of this manual. If warranty registration is not returned to ADS within such period, the warranty will expire after one year from the date of shipment.

ADS will not assume any responsibility for extra costs for installation in any area where there are jurisdictional problems with local trades or unions. If a defect in workmanship or material is found to exist within the warranty period, ADS, at its election, will either repair or replace the defective machine or accept return of the machine for full credit; provided; however, as to glasswashers, ADS obligation with respect to labor associated with any repairs shall end (a) 120 days after shipment, or (b) 90 days after installation, whichever occurs first. In the event that ADS elects to repair, the labor and work to be performed in connection with the warranty shall be done during regular working hours by a ADS authorized service technician. Defective parts become the property of ADS. Use of replacement parts not authorized by ADS will relieve ADS of all further liability in connection with its warranty. In no event will ADS warranty obligation exceed ADS's charge for the machine. The following are not covered by ADS warranty:

- a. Lighting of gas pilots or burners.
- b. Cleaning of gas lines.
- c. Replacement of fuses or resetting of overload breakers.
- d. Adjustment of thermostats.
- e. Adjustment of clutches.
- f. Opening or closing of utility supply valves or switching of electrical supply current.
- g. Cleaning of valves, strainers, screens, nozzles, or spray pipes.
- h. Performance of regular maintenance and cleaning as outlined in operator's guide.
- i. Damages resulting from water conditions, accidents, alterations, improper use, abuse, tampering, improper installation, or failure to follow maintenance and operation procedures.
- j. Wear on Pulper cutter blocks, pulse vanes, and auger brush.

Examples of the defects not covered by warranty include, but are not limited to: (1) Damage to the exterior or interior finish as a result of the above, (2) Use with utility service other than that designated on the rating plate, (3) Improper connection to utility service, (4) Inadequate or excessive water pressure, (5) Corrosion from chemicals dispensed in excess of recommended concentrations, (6) Failure of electrical components due to connection of chemical dispensing equipment installed by others, (7) Leaks or damage resulting from such leaks caused by the installer, including those at machine table connections or by connection of chemical dispensing equipment installed by others, (8) Failure to comply with local building codes, (9) Damage caused by labor dispute or acts of Mother Nature - events, i.e. flood, lightning, hurricane, fire..

**Warranty of Parts:** ADS warrants all new machine parts produced or authorized by ADS to be free from defects in material and workmanship for a period of 90 days from date of invoice. If any defect in material and workmanship is found to exist within the warranty period ADS will replace the defective part without charge.

**DISCLAIMER OF WARRANTIES AND LIMITATIONS OF LIABILITY.** ADS WARRANTY IS ONLY TO THE EXTENT REFLECTED ABOVE. ADS MAKES NO OTHER WARRANTIES, EXPRESS OR IMPLIED, INCLUDING, BUT NOT LIMITED, TO ANY WARRANTY OF MERCHANTABILITY, OR FITNESS OF PURPOSE. ADS SHALL NOT BE LIABLE FOR INCIDENTAL OR CONSEQUENTIAL DAMAGES. THE REMEDIES SET OUT ABOVE ARE THE EXCLUSIVE REMEDIES FOR ANY DEFECTS FOUND TO EXIST IN ADS DISHWASHING MACHINES AND ADS PARTS, AND ALL OTHER REMEDIES ARE EXCLUDED, INCLUDING ANY LIABILITY FOR INCIDENTALS OR CONSEQUENTIAL DAMAGES.

ADS does not authorize any other person, including persons who deal in ADS dishwashing machines to change this warranty or create any other obligation in connection with ADS Machines.

# HUB-40

Item # 411-1040

## Undercounter High Temperature Dishwashing Machine with Built-in Booster Heater



Photo is for general visual representation only. Please refer to specifications for the latest detailed product information.



**American Dish Service**  
Manufacturers of Ware Washing Equipment

### STANDARD FEATURES

- ENERGY STAR® Qualified
- "Extenda-Cycle" – extends the cycle time to ensure 180°F/82°C final rinse
- Universal power 208-240 volt and/or single to three phase field convertable
- Smooth start for protection from breakage
- Built-in booster for 180°F/82°C final rinse water (standard 70°F/39°C rise)
- Detergent and rinse aid pumps accompanied by priming switches
- Noise-reducing double wall design
- Interchangeable Stainless steel wash/rinse arms
- Ease of use controls
- Complete cycle time 90 seconds
- Delime capability
- 1 HP motor with pump drain

### OPTIONS & ACCESSORIES

- Dish Table with Sink\*
  - 099-8020: 48" Right Hand
  - 099-8021: 48" Left Hand
- 17" Stand Stainless Steel
- Leg Stand (8")
- 3 Phase Connection (in-field conversion)
- 1" Caster Kit

\*Not available with 17" Stand / 8" leg stand or casters

### American Dish Service

900 Blake Street | Edwardsville, Kansas, 66111  
Phone: 913.422.3700 | Toll-Free: 800.922.2178 | Fax: 913.422.6630  
orders@americandish.com | [americandish.com](http://americandish.com)

# HUB-40

## Undercounter High Temperature Dishwashing Machine with Built-in Booster Heater

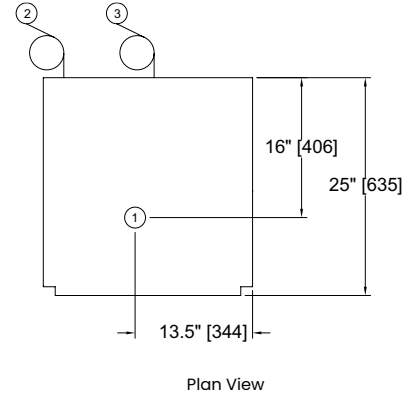
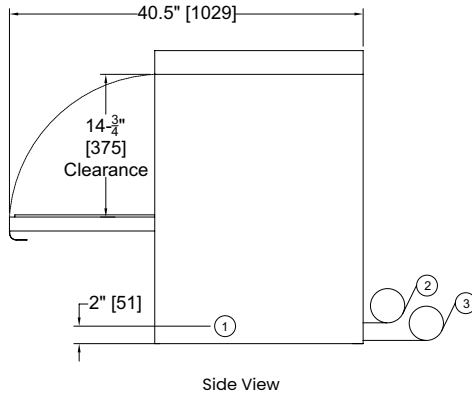
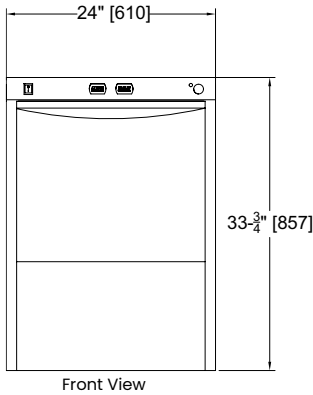

### SPECIFICATIONS

#### Capacities\*

Cycle time (seconds) . . . . . 90  
Racks per hr. . . . . 40

#### Motor horsepower

Wash . . . . . 1

#### Water consumption

U.S. Gal./Imperial Gal.  
(Max. use) per hr. . . . . 23.4/19.2  
U.S. Gal./Imperial Gal.  
per rack. . . . . 0.78/0.64

#### Temperatures °F/°C

Wash . . . . . 150/66  
Rinse . . . . . 180/82

#### Heating

Tank heat, electric, kW . . . . . 2.0

#### Time Cycle in Seconds

Wash . . . . . 70  
Rinse . . . . . 14  
Total cycle. . . . . 90

#### Standard 20" x 20" [508 x 508] Rack Complement

Dish . . . . . 1  
Open . . . . . 1  
\* at 140°F incoming water

### UTILITIES

#### 1 Electrical

208-240/60/1; 3 wire plus ground, (See Box).  
208-240/60/3; 4 wire plus ground, (See Box).  
Field convertible to accept 3 phase power, see service manual for details

#### 2 Hot Water

1/2" supply; 110°F/43°C Min. hot water connection for 70°F/39°C rise booster. Incoming supply pressure must maintain a Flow pressure of 20-22 PSI. Machine equipped with 3/4" [19] hose connector.

#### 3 Pumped Drain

5/8" [15.9] I.D. flexible reinforced hose, 6 ft. [1829] long.  
Max. drain flow 15 US gpm. [12.5 imp gal] Max. drain height 3 ft. [914]

#### 6kW HUB-40 with 70°F/39°C Booster Rise

Elec. Specs	Rated Amps	Minimum Supply Ckt. Conductor Ampacity	Maximum Overcurrent Protective Device
208/60/1	32	40	40
240/60/1	36	40	40
208/60/3	22	30	30
240/60/3	24	40	30

Volume crated: 15 cu. ft./0.42 cu.m

Shipping weight crated: 215 lbs./97.5 kg.

Dimensions shown in inches and [millimeters]

Due to an ongoing value analysis program, specifications contained in this catalog are subject to change without notice.

**Warning** Plumbing and electrical connections should be made by qualified personnel who will observe all the applicable plumbing, sanitary and safety codes and the National Electrical Code.

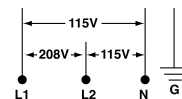

**Note:** Electrical supply service must be a 3-wire plus ground for connection shown.



an Ali Group Company



### American Dish Service

900 Blake Street | Edwardsville, Kansas, 66111  
913.422.3700 | Toll-Free: 800.922.2178 | Fax: 913.422.6630  
orders@americandish.com | [americandish.com](http://americandish.com)

HUB40-V01-R1.0

# Table of Contents

Models ADS HUB-40-HIGH TEMP

Revision History	i
Limited Warranty	ii
Model Descriptions	v
<b>Installation</b>	<b>1</b>
Receiving	1
Placement	1
Electrical Connections	2
Electrical Connections-Wiring Diagrams	3
Connecting Incoming Power to the Main Terminal Block (1 and 3 PH)	4
Booster Heater Conversion from 1 to 3 PH	7
Water Connections	10
Drain Connection	11
Booster Fill Switch - (Filling the booster for the first time)	14
Chemical Connections	16
Pumps and Injection Points - Detergent and Rinse-aid Dispensing Pumps	17
Pump Priming - Detergent and Rinse-aid Dispensing Pumps	19
Pump and Fill Adjustments - Detergent and Rinse-aid Dispensing Pumps	20
<b>Operation</b>	<b>22</b>
Loading Dish Racks - All Models	22
Normal Wash Mode	24
Normal Wash Mode	25
Rinse Sentry Mode	26
Extended Wash Mode	26
Drain Mode - All Models	27
<b>Cleaning</b>	<b>28</b>
Cleaning the Wash Tank	28
Cleaning the Wash Arms - All Models	29
Cleaning the Rinse Arms	30
Cleaning Scrap Screen and Sump Strainer	31
Deliming	32
Deliming	33
<b>Maintenance</b>	<b>34</b>
Daily, Weekly, Monthly	34

## Receiving

### NOTE:

The installation of your dishwasher must be performed by qualified service personnel familiar with food service equipment and must comply with all local health codes. Problems due to improper installation are not covered by the Limited Warranty.

### NOTE:

The installation of the dishwasher must comply with all local electrical, plumbing, health and safety codes or in the absence of local codes, installed in accordance with the applicable requirements in the National Electrical Code, NFPA 70, Canadian Electrical Code (CEC), Part 1, CSA C22.1; and the Standard for Ventilation Control and Fire Protection of Commercial Cooking Operations, NFPA 96.

## Placement

### CAUTION:

Be careful when lifting and moving the dishwasher to prevent damage to the machine.

1. Inspect the outside of the dishwasher carton for signs of damage.
2. Remove the carton and inspect the dishwasher for damage.
3. Check for any options or accessories that may have shipped with your dishwasher.
4. Compare the installation site utility connections with the dishwasher utility connections and make sure they are the same.
5. The dishwasher can be installed as a free-standing unit or under a counter-top. The typical counter-top height in most locations is 34" [86cm].
6. It is highly recommended that the underside of the counter-top be clad in metal.
7. Under counter installations should provide storage space for the dishwasher chemical supply containers. Do not elevate the containers above the finished floor.
8. Chemical supply containers should be placed as close to the machine as possible and the chemical tubing taped to the back of the machine should be repositioned before permanently placing the machine.
9. Place the dishwasher in its permanent location.
10. The dishwasher has 4 adjustable feet for leveling.
11. Level the dishwasher front-to-back and side-to-side.

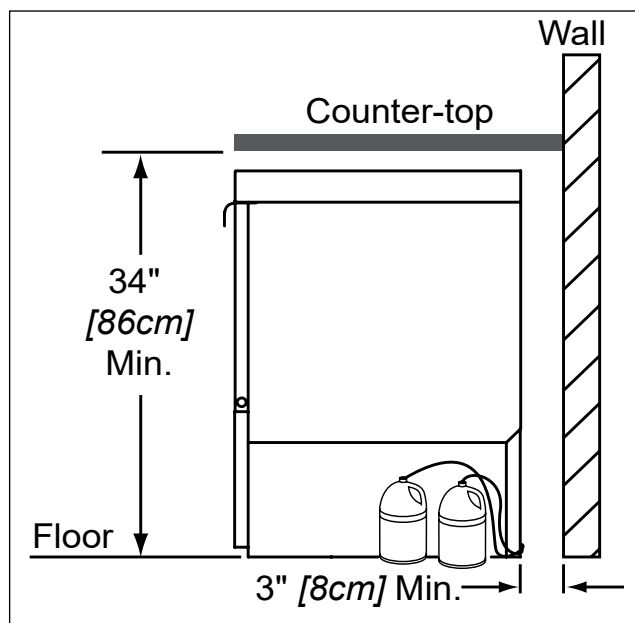

## 1PH and 3PH Wiring Diagrams

**! ATTENTION !**  
ALL DISHWASHERS ARE SHIPPED FROM THE FACTORY WIRED FOR SINGLE PHASE OPERATION UNLESS SPECIFIED AT THE TIME OF ORDER.  
IF YOU ARE CONVERTING A SINGLE PHASE MACHINE TO THREE PHASE BE SURE TO FOLLOW THE BOOSTER WIRING INSTRUCTIONS ON PAGES 7-8.

Refer to the connection diagrams below to connect main incoming power to the dishwasher.

**THREE PHASE POWER CONNECTION**

**! VERY IMPORTANT !**

THE ELECTRICAL POWER MUST BE A 4-WIRE PLUS GROUND SUPPLY WHICH INCLUDES A CURRENT CARRYING NEUTRAL.

**HOW TO CONNECT 3 PHASE POWER**

1. Check the data plate on the front of the dishwasher for the phase of the machine.
- If the data plate says the machine is 3 Phase, then connect a 3 PH power supply.
2. Remove the lower access panel.
3. Pull power connection box forward and out.
4. The Main Terminal Block has terminals for L1, L2, L3, Neutral and Ground.
5. Connect ground, then connect L1, L2, L3 to 208-230VAC.
6. Connect a current carrying neutral to N.
7. Main power connections are complete.

**SINGLE PHASE POWER CONNECTION**

**! VERY IMPORTANT !**

THE ELECTRICAL POWER MUST BE A 3-WIRE PLUS GROUND SUPPLY WHICH INCLUDES A CURRENT CARRYING NEUTRAL.

**HOW TO CONNECT 1 PHASE POWER**

1. Check the data plate on the front of the dishwasher for the phase of the machine.
- If the data plate says the machine is 1 Phase, then connect a 1 PH power supply.
2. Remove the lower access panel.
3. Pull power connection box forward and out.
4. The Main Terminal Block has connections for L1, L2, L3, Neutral and Ground.
5. Connect ground, then connect L1, L2 to 208-230VAC.
6. Connect a current carrying neutral to N.
- DO NOT CONNECT POWER TO L3.**
7. Main Power connections are complete.

## Connecting Incoming Power to the Main Terminal Block



**WARNING:**

Electrocution or serious injury may result when working on an energized circuit.

Disconnect power at the main breaker or service disconnect switch before working on the circuit.

Lock-out and tag the breaker or service disconnect switch to indicate that work is being performed on the circuit.

**! VERY IMPORTANT !**

PROVIDE A 3 FEET/1 METER SERVICE LOOP IN THE POWER SUPPLY CABLE TO SERVICE THE DISHWASHER.

**! SINGLE PHASE POWER REQUIREMENT !**

**SINGLE PHASE**

The electrical power must be a 3-wire plus ground supply which includes a current carrying neutral.

**! THREE PHASE POWER REQUIREMENT !**

**THREE PHASE**

The electrical power must be a 4-wire plus ground supply which includes a current carrying neutral.

## Connecting Incoming Power to the Main Terminal Block

Refer to the photo below:

1. Remove the lower front dishwasher panel.
2. Remove the retaining fasteners (A) from the swing-out brackets and swing the chemical pump bracket (B) and the chemical circuit board bracket (C) out of the way as shown.

(continued on next page)

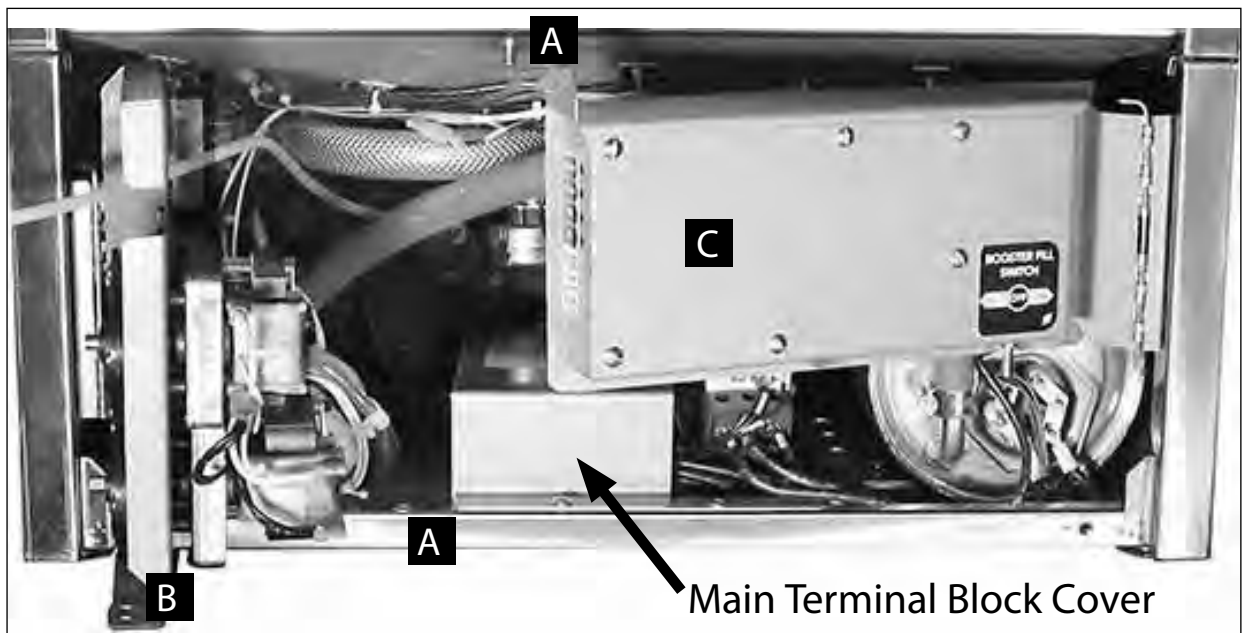

## Connecting Incoming Power to the Main Terminal Block for 1PH and 3PH Machines with Boosters

(continued from previous page)

Refer to the photo below:

3. Provide a 3 foot/1 meter service loop in the power supply cable to service the machine
4. Route the power cable from the rear of the machine to the terminal block making sure the cable does not touch the booster tank.
5. Connect the power cable to the terminal block bracket using a suitable strain relief connector.
6. Connect the power wires according to the wiring diagrams on page 3 for either single phase or three phase operation.
7. Swing the chemical pump bracket and the chemical board back into position and secure with the existing fasteners.

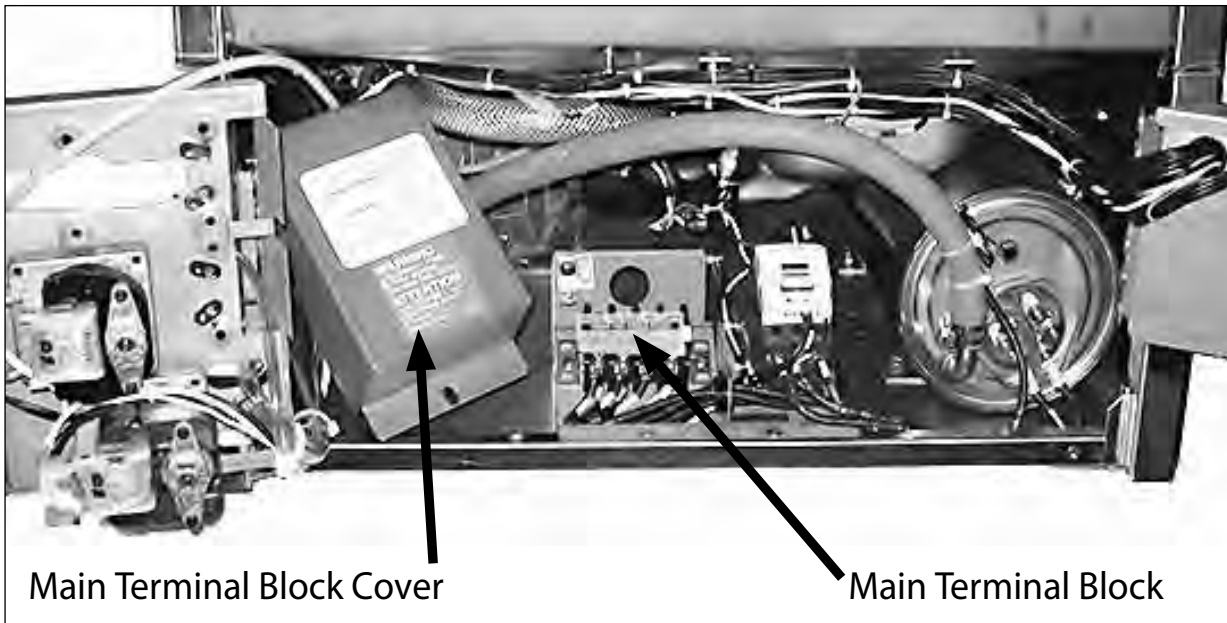

## Booster Heater Conversion from 1PH to 3 PH Operation

**! VERY IMPORTANT !**

THE BOOSTER HEATER IS WIRED FOR 1PH OPERATION WHEN SHIPPED.  
FOLLOW THE INSTRUCTIONS BELOW TO WIRE THE BOOSTER FOR 3PH.

**WARNING:**

Electrocution or serious injury may result when working on an energized circuit.

Disconnect power at the main breaker or service disconnect switch before working on the circuit.

Lock-out and tag the breaker or service disconnect switch to indicate that work is being performed on the circuit.

1. To convert the booster heater from single phase to three phase operation, locate the booster wire labeled 1H3 that is cable-tied to the booster hose.
2. Remove the shrink insulation from the terminal and connect to the booster heater element as shown in the wiring diagram on page 8.

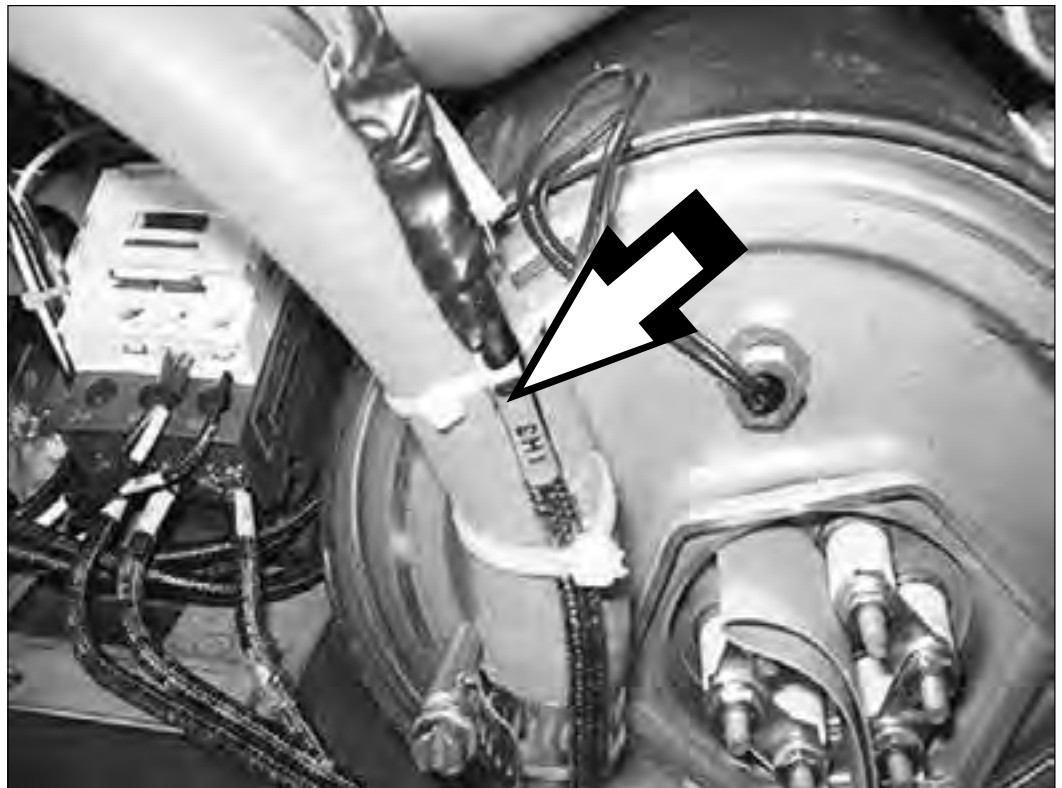

The three phase booster wire (1H3) is cable-tied to the hose adjacent to the booster tank.

## Booster Heater Conversion from 1PH to 3 PH Operation (continued)

**! VERY IMPORTANT !**

THE BOOSTER HEATER IS WIRED FOR 1PH OPERATION WHEN SHIPPED.  
FOLLOW THE INSTRUCTIONS BELOW TO WIRE THE BOOSTER FOR 3PH.

3. Disconnect the existing booster heater wires and change the booster heater element jumpers as shown in the illustration below
4. Connect wires 1H1, 1H2, and 1H3 as shown below .

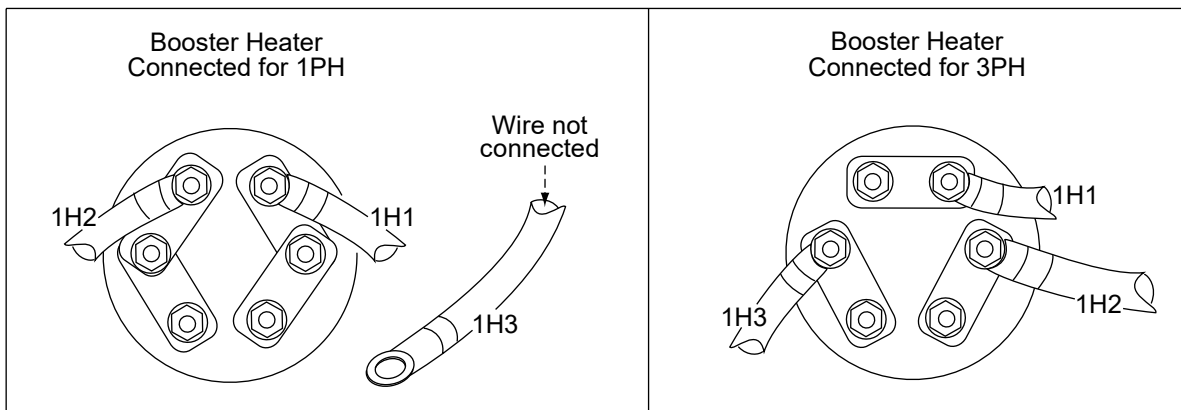

Wiring Diagram - Booster heater element connections shown for 1 phase and 3 phase operation.

5. A replacement 3PH data plate is stowed on the back of the lower front access panel.
6. Replace the existing 1PH data plate on the front of the panel with the new 3PH data plate. Discard the 1PH data plate.
7. Refer to the instructions on page 3 to connect the main incoming power to the machine.

## Completing the 1PH to 3PH Electrical Conversion

**! ATTENTION !**  
**CHANGE THE DATA PLATE ON THE LOWER FRONT PANEL OF THE MACHINE**  
**AFTER THE MACHINE IS WIRED FOR 3PH AND THE BOOSTER HEATER IS CONNECTED**  
**FOR 3PH.**

1. The data plate on the dishwasher lower front panel must be changed after the machine is converted from single phase operation to three phase operation.
2. Locate the replacement data plate stowed on the back of the lower front panel.
3. Remove the paper backing from the label and carefully place it over the existing data plate label making sure it covers the label completely .
4. Re-install the lower front panel to complete the conversion.



A three phase data plate is located on the back of the lower front panel.

## Water Connections

**! VERY IMPORTANT !**

Make sure the flexible water supply and drain hoses are not kinked.

Plumbing connections must allow the machine to be pulled out for service and cleaning.

Plumbing connections must comply with national, provincial local plumbing and sanitary codes. Only qualified service personnel familiar with food service equipment should install the machine.

The installing plumber must thoroughly flush the water supply line to remove all debris BEFORE connecting the water supply line to the machine.

1. All models have a 6 ft. flexible hot water fill hose with a 3/4" female garden hose connector.
2. A 1/2" or larger main incoming supply line must be installed to the dishwasher.
3. A 1/2" or larger shut-off valve should be installed in the main water supply, as close to the dishwasher as possible for servicing.
4. The hot water supply must provide a minimum of 180°F/82°C, measured at the dishwasher. A pressure regulating valve, PRV, (supplied), must be installed after the shut-off service valve if the incoming flow pressure exceeds 20-22 psi.

The hot water supply must provide a minimum of 140°F/60°C, measured at the dishwasher for 40°F/22°C rise booster or 110°F/43°C for 70°F/39°C rise booster.

A pressure regulating valve, PRV, (supplied), must be installed after the shut-off service valve if the incoming flow pressure exceeds 20-22 psi.

5. A water hardness of 3 grains/gal (US) [5.3 mg/L] or less is recommended. Excessively hard water will negatively impact wash results.

## Drain Connections

**! VERY IMPORTANT !**

Do not connect the drain hose to a disposer. The dishwasher will not drain correctly.

Refer to the photo below.

1. All models are equipped with a 6 ft.. 5/8" I.D. drain hose. The maximum drain height connection must not exceed 3 ft.[1 m] and must be vented to prevent the wash tank from siphoning.
2. The drain hose is located at the rear of the dishwasher , and is secured to the rear of the machine by two clamps to maintain an anti-siphoning loop in the drain hose.
3. A 3/4" hose barb fitting is strapped to the drain hose prior to shipment. The service part number for the hose barb is P/N 0512321.
4. Additional plumbing parts must be supplied by the plumbing installer.
5. The maximum drain flow is 15 US gpm/12.4 imp gpm/60 lpm.

**! ATTENTION !**

FAILURE TO FOLLOW THE DRAIN CONNECTION INSTRUCTIONS MAY VOID THE WARRANTY.

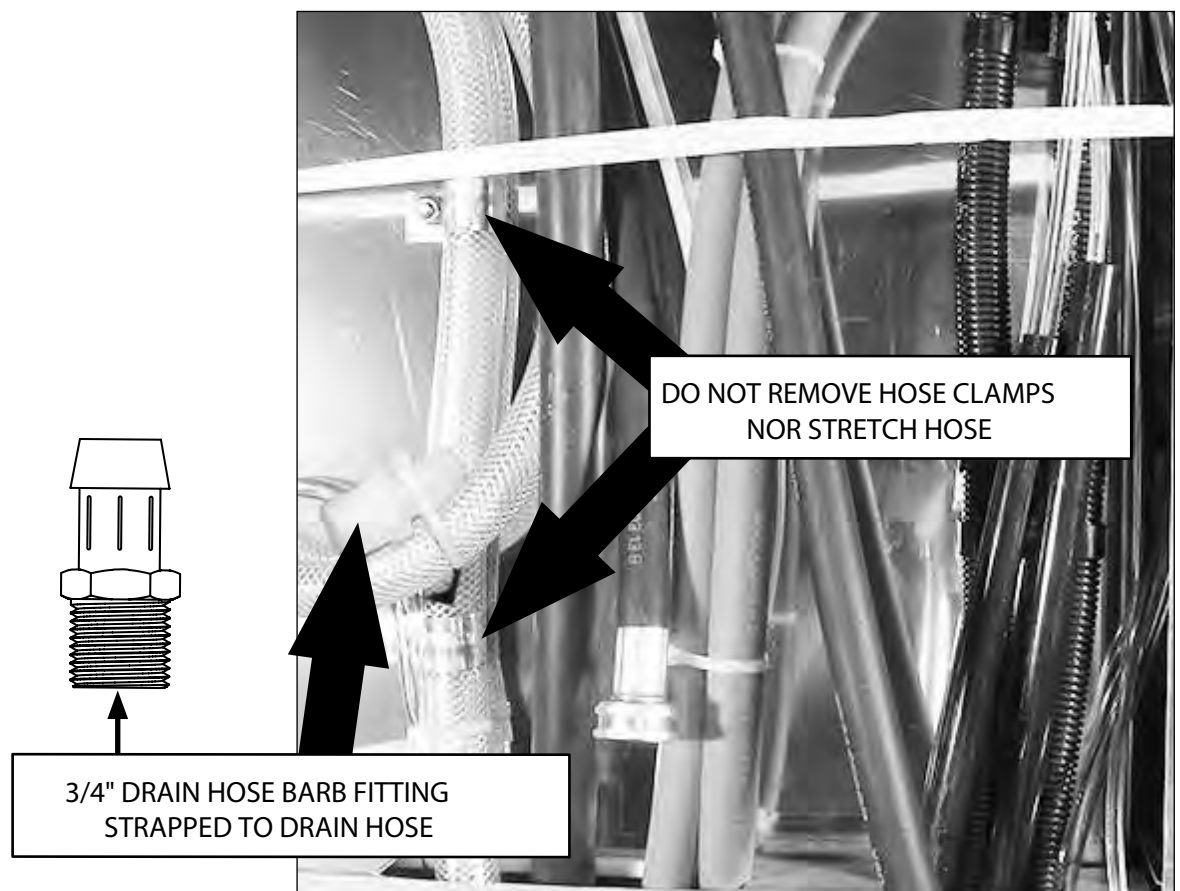

## Drain Connection (continued)

**NOTE**

Plumbing connections must comply with national, provincial local plumbing and sanitary codes.

DO NOT REMOVE THE CLAMPS HOLDING THE DRAIN HOSE TO THE BACK OF THE DISHWASHER.

DO NOT CONNECT THE DRAIN HOSE TO A DISPOSER.

DO NOT REDUCE THE SIZE OF THE DRAIN HOSE CONNECTION NOR USE A DOMESTIC DRAIN FITTING.

DO NOT ADD ADDITIONAL LENGTH TO THE DRAIN HOSE.

DO NOT ALLOW THE DRAIN HOSE TO KINK.

### For a Direct Drain Connection:

1. Install the drain hose to an 1-1/2" or larger vented "WYE" drain fitting.
2. CONNECTION TO A "TEE" FITTING WILL PREVENT THE DISHWASHER FROM DRAINING COMPLETELY.

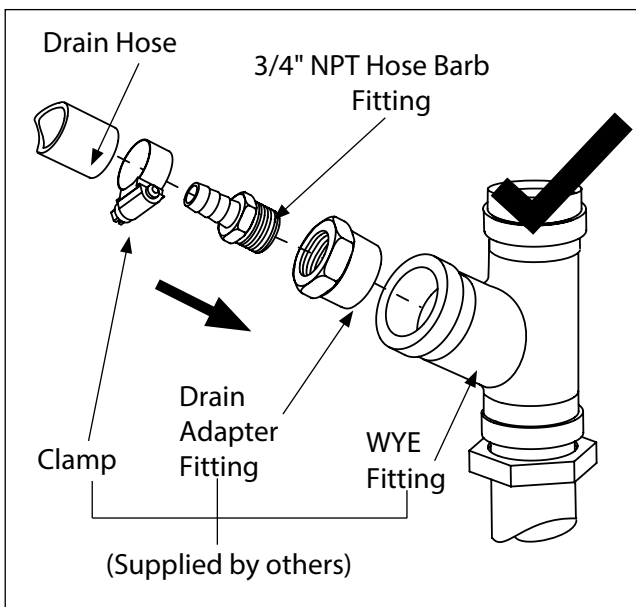

**DO**  
connect the dishwasher flexible drain hose to a vented WYE drain fitting.

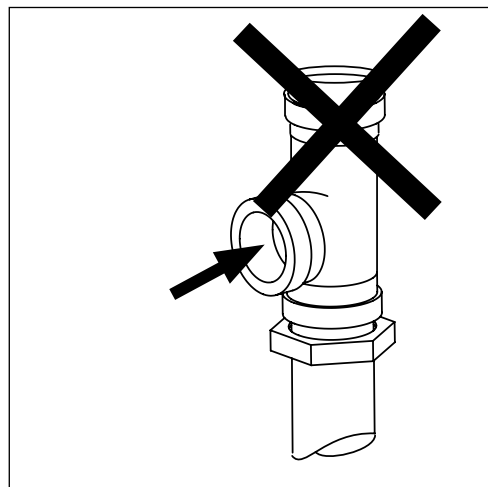

**DO NOT**  
connect the dishwasher flexible drain hose to a TEE drain fitting.

## Drain Connection

## For an Indirect Drain Connection:

1. A 1" [25.4mm] minimum air gap must be provided between the outlet of the dishwasher drain hose and the flood-level rim of the floor drain, floor sink or any other locally approved drain receptacle. (See illustration below.)

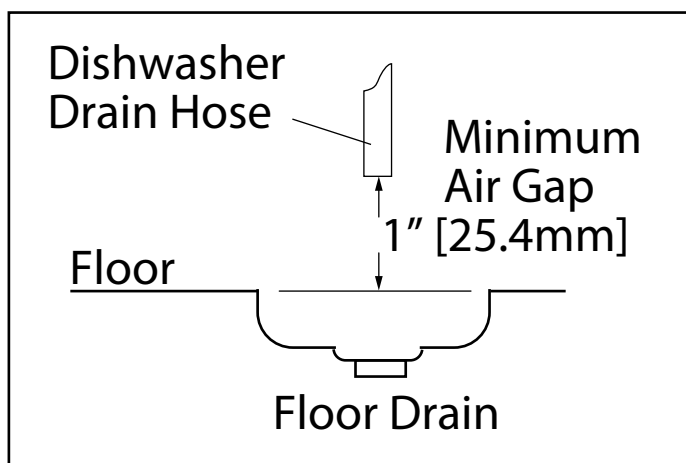

**! VERY IMPORTANT !**  
**IMPROPER INSTALLATION OF MACHINE DRAIN HOSE.**  
Machine drain problems are often the result of improper installation and may not be covered by the limited warranty.

## Booster Fill Switch - (Filling the booster tank for the first time)

**! CAUTION !**  
AVOID PERMANENT DAMAGE TO THE BOOSTER HEATER

DO NOT TURN THE DISHWASHER POWER SWITCH  
ON WHEN FILLING THE BOOSTER FOR THE FIRST TIME.

THE BUILT-IN BOOSTER TANK WAS DRAINED BEFORE SHIPMENT AND  
MUST BE REFILLED BEFORE OPERATING THE DISHWASHER.

THE BOOSTER FILL SWITCH IS LOCATED BEHIND THE LOWER FRONT PANEL ON THE  
RIGHT SIDE OF THE MACHINE.

### To refill the booster for the first time:

1. Turn the main breaker or disconnect switch to the dishwasher ON.
2. DO NOT PUSH THE DISHWASHER ON-OFF/DRAIN POWER SWITCH TO THE ON POSITION.
3. Locate the booster fill switch and note the switch is in the OFF position.

(continued on next page)



## Booster Fill Switch - (Filling the booster tank for the first time)

4. PUSH AND HOLD the booster fill switch in the FILL position until water starts filling inside the wash compartment.
5. Release the FILL switch.

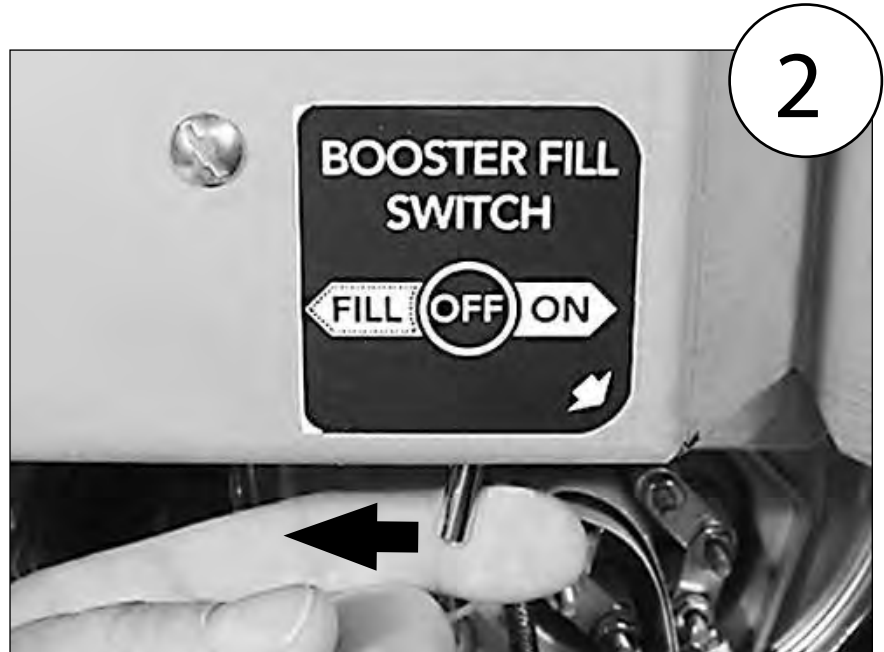

6. PUSH the booster fill switch to the ON position and release.
7. The booster fill operation is complete.
8. Replace the lower front panel on the machine.



## Chemical Connections

### **! VERY IMPORTANT !**

ALWAYS USE A COMMERCIAL-GRADE NON-CHLORINATED DETERGENT.  
PLACE THE CHEMICAL SUPPLY CONTAINERS AS CLOSE TO THE MACHINE AS POSSIBLE.  
DO NOT ELEVATE THE CHEMICAL CONTAINERS ABOVE THE FINISHED FLOOR.

### **! VERY IMPORTANT !**

Contact a chemical supplier for detergent and rinse-aid chemicals. The chemical supplier must adjust the chemical dispensing pumps for water hardness and food soil types.

## Chemical Dispensing Pumps

1. The detergent and rinse-aid pumps are located on the lower left-side of the machine behind the lower -front access panel.
2. Each pump is equipped with 6 feet [1.8 m] of pick-up tubes consisting of supply tubing, stiffener tubes, and strainers.
3. The pick-up tubes are stowed on the back of the machine for shipping.
4. A red label marked DETERGENT and a blue label marked RINSE-AID identify the chemical lines.

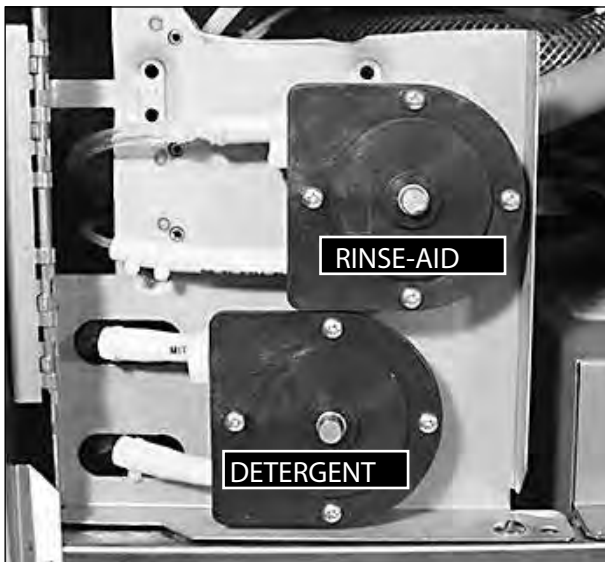

The pumps are located on the left-side behind the lower front panel of the dishwasher.

## Pumps and Injection Points - Detergent and Rinse-aid Dispensing Pumps

2. For the detergent enters the wash tank compartment through a fitting on the back right corner of the wash compartment. Rinse-aid enters the final rinse piping through a fitting near the vacuum breaker.

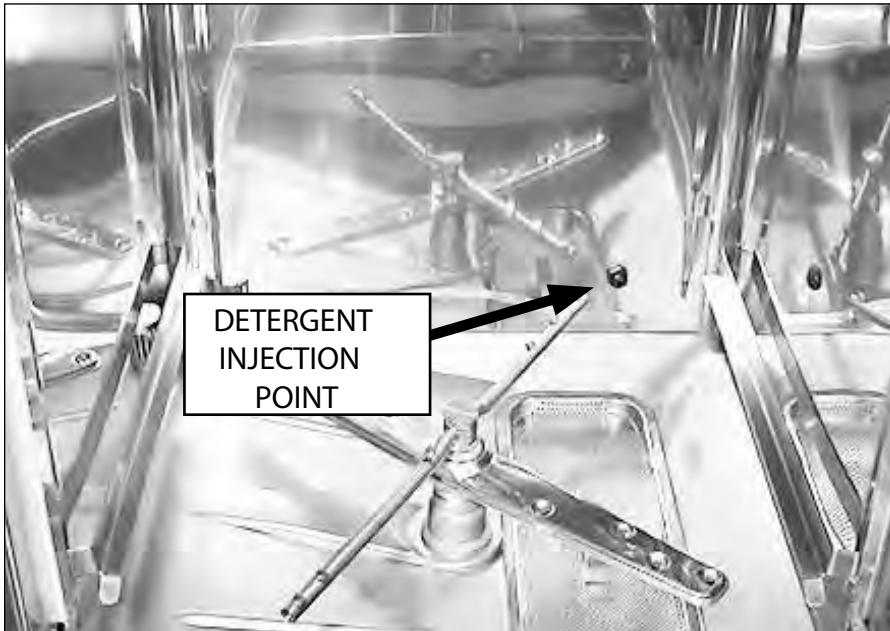

## Pumps and Injection Points - Detergent and Rinse-aid Dispensing Pumps

Priming the Dispensing Pumps**! VERY IMPORTANT !**

The chemical dispensing pumps must be primed before operating the dishwasher and whenever the chemical container is changed.

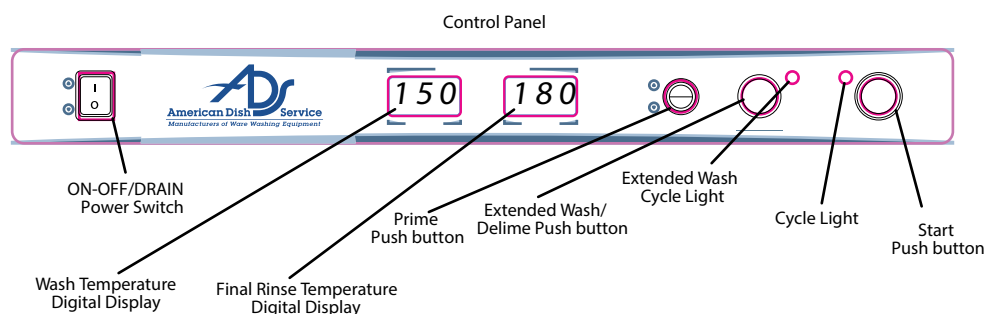

1. The chemical dispensing pump supply lines must be primed before they will pump the chemicals properly .
2. Make sure the chemical containers are full and the correct pick-up tubes are in their containers.
3. Turn the dishwasher power switch ON. The switch will illuminate and the dishwasher will fill with water.
4. Open the dishwasher door , then push and hold the prime push button UP to the DETERGENT position until detergent is observed entering the wash tank compartment through the fitting located on the back right corner of the tank. Release the push button.
5. Push and hold the prime push button DOWN to the Rinse-aid position until you see air bubbles moving through the rinse-aid tubing coming out of the chemical container . Release the push button.
6. Close the door to complete the priming operation.

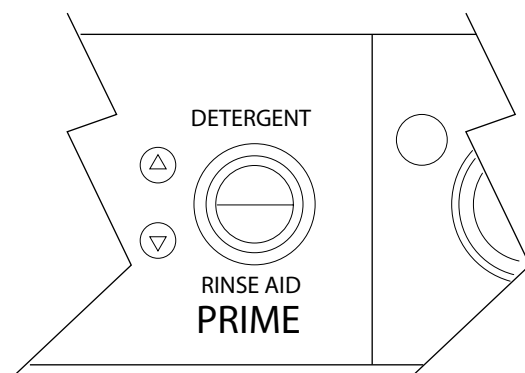

(continued on next page)

## Detergent and Rinse-aid Dispensing Pumps - Pump and Fill Adjustments

### **! ATTENTION !**

The amount of dispensed chemical is determined by the run time of the dispensing pump.

Refer to the photo below:

1. The chemical dispensing pump run and the tank fill adjustment screws are located on the end of the chemical circuit board swing-out bracket.
2. It is not necessary to swing the bracket out to make adjustments, but if desired, remove the mounting nut (A) and swing the bracket (B) out and to the right.
3. Refer to the next page for adjustment instructions.

### **! VERY IMPORTANT !**

INSPECT & REPLACE THE CHEMICAL DISPENSING PUMP SQUEEZE TUBES EVERY SIX MONTHS.

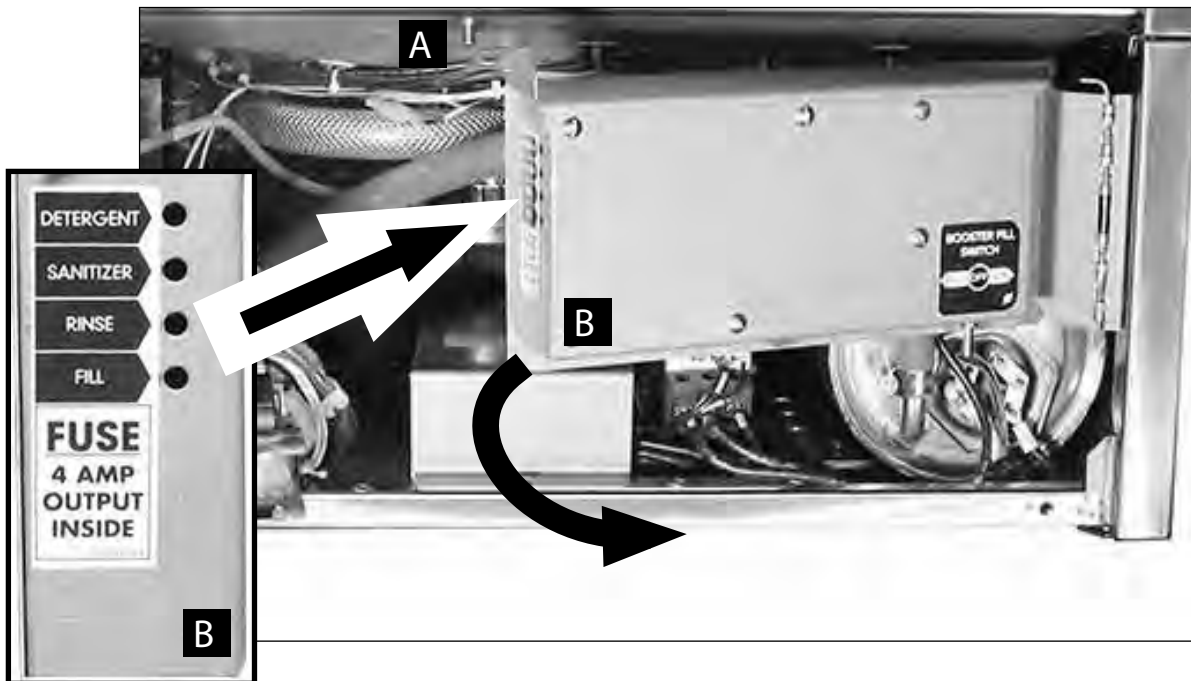

### **! VERY IMPORTANT !**

Contact a chemical supplier for detergent and rinse-aid chemicals. The chemical supplier must adjust the chemical dispensing pumps for water hardness and food soil types.

## Loading Dish Racks

**! VERY IMPORTANT !**  
DO NOT OVERLOAD THE DISH RACK.  
LOAD ONE DISH RACK INTO THE MACHINE AT A TIME.

1. Prescrap and rinse the wares before loading to remove large food particles.
2. Load soiled wares into the dish rack. Place plates and glasses in a peg rack. Place cups and bowls in a flat bottom rack. Place utensils in a single layer in a flat-bottom rack. Place pots and pans in a flat-bottom rack.

Do not overload the dish rack. Wash one dish rack at a time.

3. Slide one dish rack into the wash compartment making sure that wares do not interfere with the rotating spray arms. Do not wash more than one dish rack at a time.

Prescrap and rinse wares before loading into the machine.

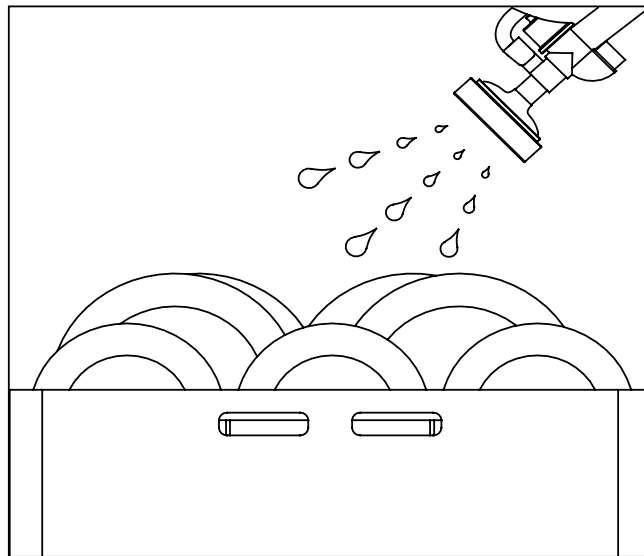

Load plates and glasses in a peg rack.

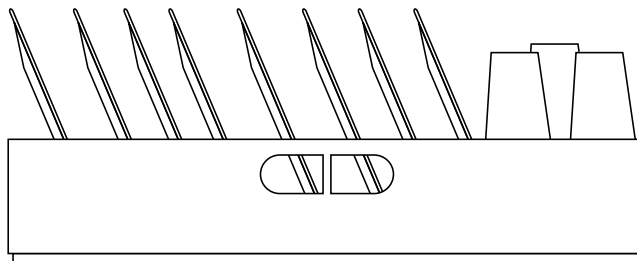

Loading Dish Racks (continued)

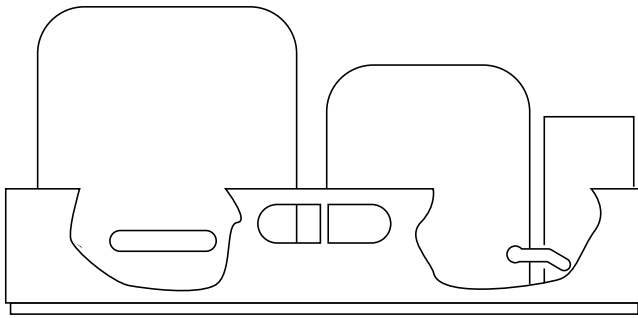

Load pots and pans in a flat-bottom rack.

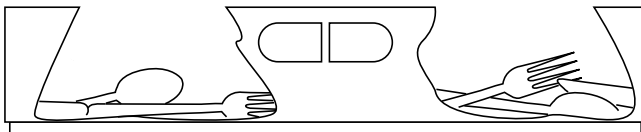

Load utensils in a single layer in a flat-bottom rack.

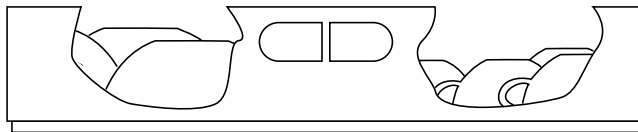

Load cups and bowls in a flat-bottom rack.

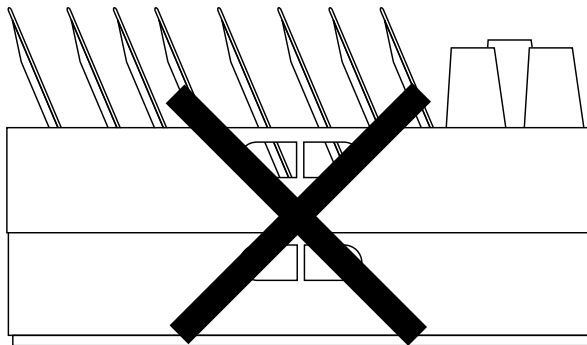

**NEVER** stack dish racks.  
Wash one dish rack at a time.

Normal Wash Mode

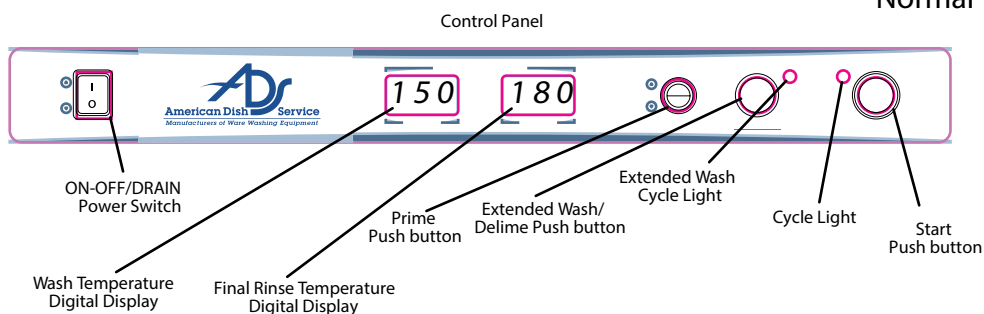

1. Close the door .
2. Push the dishwasher Power Switch UP to turn the power ON.
3. The power switch will illuminate and the machine will fill with water.
4. Check the pressure gauge as the machine fills and make sure the incoming water pressure is between 20-22 PSI.
5. Wait until the wash temperature gauge indicates a minimum of 150°F/66°C.

PLACE AN EMPTY DISHRACK IN THE MACHINE AND RUN THE FIRST CYCLE EMPTY TO HEAT THE WASH TANK INTERIOR.

6. Load the dish rack into the machine. Wash one dish rack at a time.
7. Close the door , then press the START BUTTON for 1 second. The green in-cycle light will illuminate and the wash cycle will begin. The total cycle is approximately 90 seconds.
8. Opening the door during a cycle will stop the dishwasher. If the door is open more than 5 seconds the cycle will restart from the beginning, if open less than 5 seconds the cycle will resume where it left off when the dishwasher door is closed.
9. The final rinse cycle begins at the end of the wash cycle. The machine drains and retains a portion of the final rinse water for the next wash cycle.
10. Check the rinse temperature gauge during the final rinse. It must indicate a minimum of 180-195°F/82-91°C. The final rinse water is retained for the next wash cycle.
11. Check the pressure gauge during the final rinse to ensure the gauge reads 20-22 PSI.
12. When the green cycle light goes out, open the door and remove the rack of clean wares.

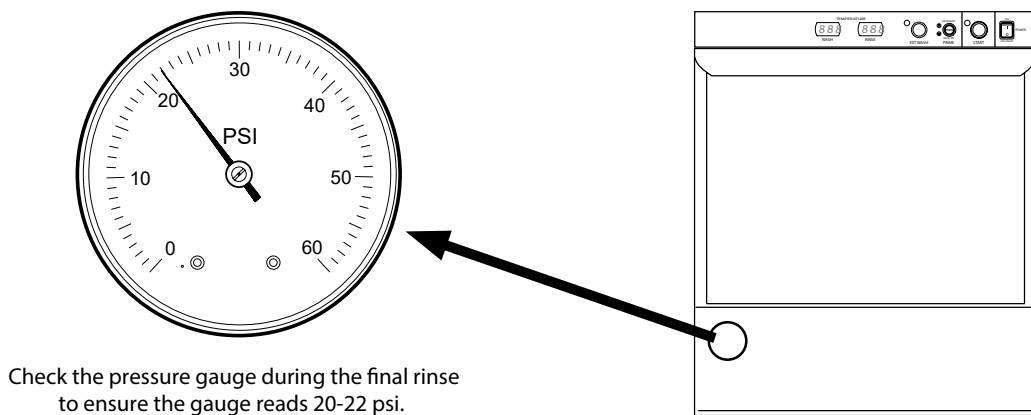

**! ATTENTION !**

**DOOR LEFT OPEN DURING WASH CYCLE**

If the dishwasher door is left open for more than 5 seconds during the normal wash mode, then the dishwasher cycle will reset to the beginning of the normal wash cycle.

**! ATTENTION !**

**RINSE SENTRY MODE WILL EXTEND WASH CYCLE TIME**

In the event that the final rinse temperature has not reached 180-195°F/82-91°C after the wash cycle, the rinse sentry will extend the wash cycle time until the booster reaches 180-195°F/82-91°C. If the proper temperature is not reached within 5 minutes, the machine will leave the rinse sentry mode and complete the cycle.

## Extended Wash Mode

The Extended Wash Mode is used to wash heavily soiled items such as pots, pans and other wares that require more washing time than the standard 90 second Normal Wash Mode. The dishwasher will remain in the Extended Wash Mode until the operator exits the mode or a maximum of 15 minutes, whichever occurs first.

1. Load a dish rack into the dishwasher , close the door and press the START button.
2. The green in-cycle light will illuminate and the dishwasher will begin a normal wash cycle.
3. Wait 10 seconds for the detergent to enter the wash compartment before pressing the EXT WASH button.

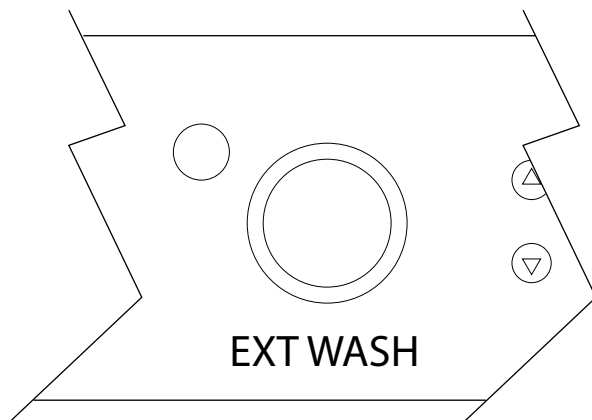

Press the EXT WASH button to place the machine into the extended wash mode to clean heavily soiled wares.

4. Press the EXT WASH button to place the dishwasher in the Extended Wash Mode.
5. The green extended wash light will illuminate indicating that the machine is in the Extended Wash Mode.
6. The dishwasher will continue to wash for a maximum of 15 minutes unless the operator presses the EXT WASH button again.
7. Press the EXT WASH button. The green extended wash light will go out indicating that the dishwasher has returned to the Normal Wash Mode.
8. The dishwasher will finish the wash cycle and perform a final rinse of the wares.

## Drain Mode

The dishwasher will enter the drain mode whenever the Power Switch is pushed down to the OFF/DRAIN position.

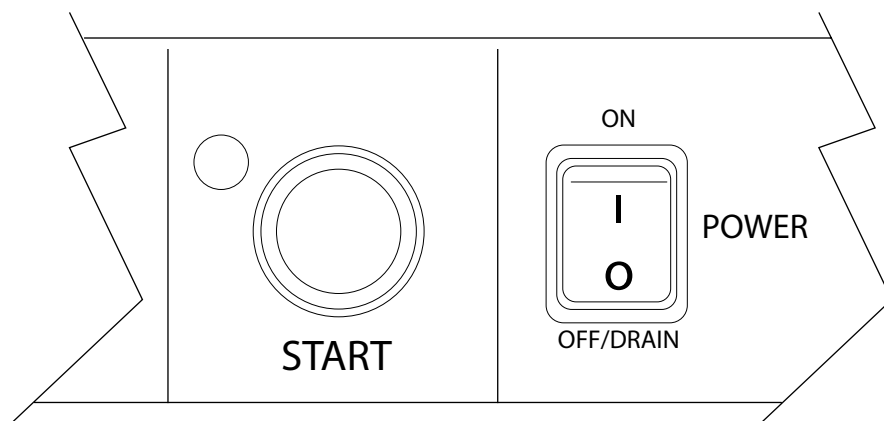

1. Push the illuminated power switch down to the OFF/DRAIN position. The power switch light will go out.
2. The cycle light will illuminate and the machine will drain.
3. The machine, will flush, perform 3 short drain cycles and then drain completely.
4. The cycle light will go out indicating that the drain cycle is complete. Do not open the door until the light goes out.

**! VERY IMPORTANT !****Draining Problems Related To Improper Installation.**

Problems with draining are often the result of improper installation. The drain hose is looped and clamped as shown in the photo below and must not be changed.

The drain hose is looped and clamped and must not be changed. Altering the drain hose routing may result in the machine's inability to drain or may cause the machine to siphon the water out of the machine.

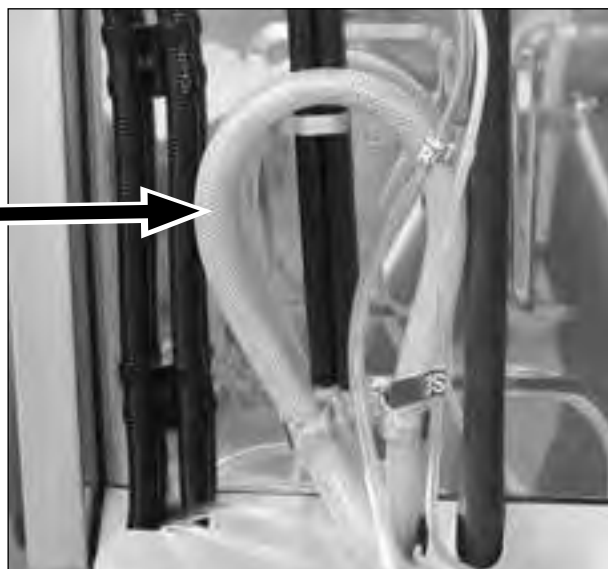

## Cleaning

## Cleaning

**! VERY IMPORTANT !**

DRAIN AND CLEAN THE DISHWASHER EVERY 2 HOURS OF CONTINUOUS OPERATION, AFTER EACH MEAL PERIOD, AND AT THE END OF THE DAY.

### All Models

#### Cleaning the wash tank:

1. Remove the upper and lower spray arms and flush clean in a sink.
2. Remove the scrap screen taking care that debris does not fall off the screen and into the wash tank or sump. Flush the screen clean in a sink. Be sure to back-flush the screen.
3. DO NOT strike the scrap screen on solid surfaces.
4. Check the sump for foreign material.
5. Clean the pump intake strainer in the bottom of the sump.
6. DO NOT scrub the interior with metal scrub pads.
7. Check the sump heating element for lime deposits and gently remove with a scouring pad. DO NOT USE METALLIC SCRUB PADS.
8. Wipe the exterior of the dishwasher with a soft clean cloth and a mild detergent.
9. Leave the door open to aid in overnight drying.

**! ATTENTION !**

DO NOT USE METALLIC SCRUB PADS TO CLEAN THE MACHINE.  
DO NOT SPRAY THE EXTERIOR OF THE MACHINE WITH WATER.

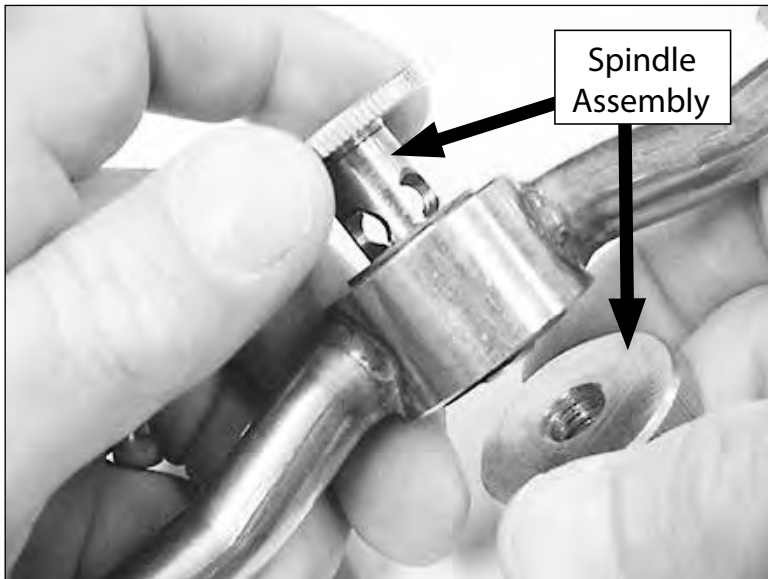

### Rinse Arms

1. There are two rinse arms in the faucet. They are interchangeable.
2. Remove the spindle assembly and end plugs in each pipe and flush the rinse pipes.
3. Inspect the rinse arm bearings for wear and replace as necessary.
4. Clean the rinse arm nozzles with a small paper clip.
5. Reassemble the rinse arm assemblies.

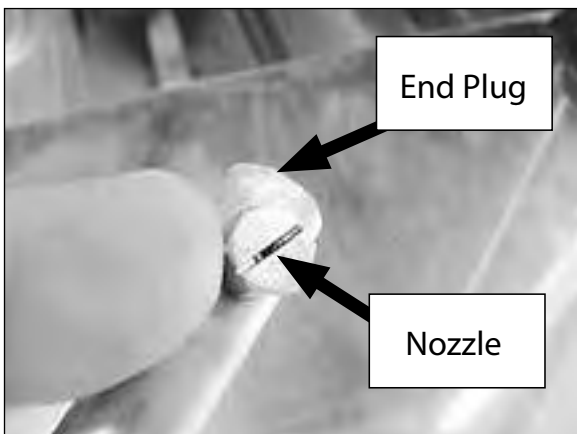

(continued on next page)

All Models - Cleaning

All Models

Scrap Screen and Sump Strainer

1. Lift the scrap screen straight up and out of the machine to prevent food particles from falling into the tank sump.
2. Flush the scrap screen in a remote sink making sure to back-flush both side of the screen.
3. Wipe the tank sump of water and debris.
4. Carefully inspect the pump intake strainer. This strainer is not removeable but must be thoroughly cleaned before reinstalling the scrap screen.

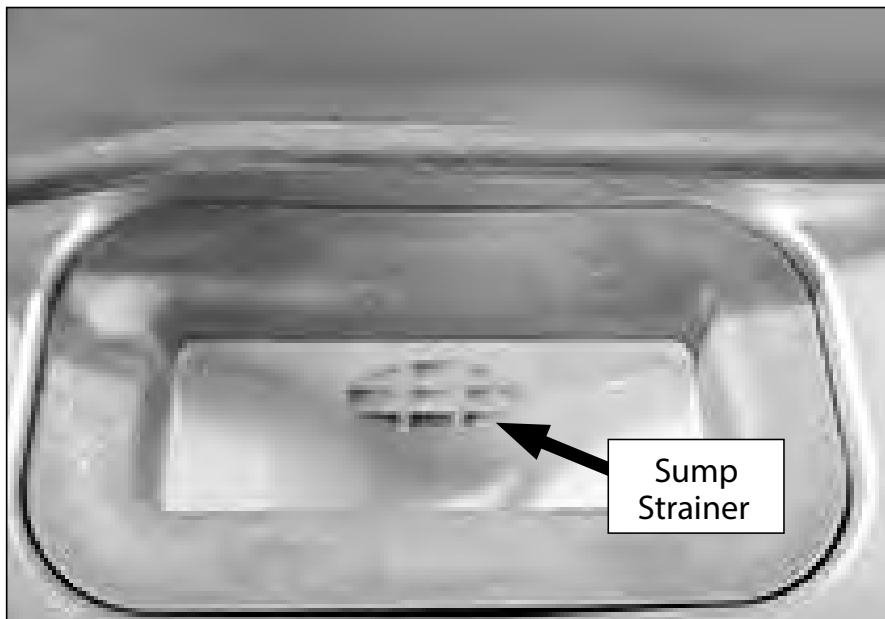
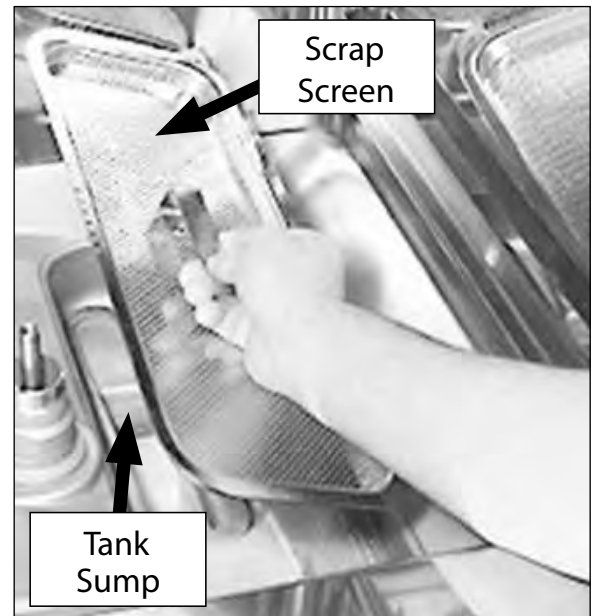

**! ATTENTION !**

A CLOGGED OR RESTRICTED SUMP STRAINER WILL PREVENT THE PROPER WASHING, RINSING AND DRAINING OF THE MACHINE.

**! ATTENTION !**

WIPE THE EXTERIOR OF THE MACHINE WITH A SOFT CLOTH AND MILD DETERGENT. DO NOT SPRAY THE EXTERIOR WITH WATER OR BLEACH.

LEAVE THE DOOR OPEN TO AID IN OVERNIGHT DRYING.

## Deliming Cautions and Warnings

A deliming agent must be used in accordance with your chemical supplier's instructions.

**DANGER:**

Death or serious injury may result when deliming solution is mixed with sodium hypochlorite sanitizing agent. Mixing may cause hazardous gases to form. Deliming solution and other acids must never be mixed with chlorine, iodine, bromine, or fluorine.

**CAUTION:**

Skin contact with deliming solutions can cause severe irritation and possible chemical burns. Always wear eye protection, rubber gloves and protective clothing when handling chemicals.

## Deliming Procedure

Follow the procedures below to de-lime the UH130, UH130B dishwasher.

1. Open the dishwasher door and remove any dish rack.
2. Turn the power switch on the dishwasher to the ON position.
3. Remove the detergent and rinse-aid chemical supply tubing from their chemical supply containers.
4. Place the detergent and rinse-aid tubing in a container of hot water.
5. Press and hold the prime switch UP in the DETERGENT position to flush all of the detergent from the supply tubing. Release the switch.
6. Press and hold the prime switch DOWN in the RINSE AID position to flush all of the rinse-aid from the supply tubing. Release the switch.
7. Close the door and run 4 empty cycles to flush any chemicals from the dishwasher tank
8. Always wear eye protection, rubber gloves and protective clothing when handling chemicals.
9. Open the door and carefully add the deliming chemical to the wash tank in accordance with the chemical supplier's instructions. Be careful to avoid splashing.
10. Close the door and press the START button to run a dishwasher cycle.
11. Check the deliming results and if scale is still present repeat steps 8-9.
12. Run 4 empty cycles to flush any deliming chemicals from the machine.
13. Return chemical supply tubing to their containers and prime the chemical lines.
14. Return the dishwasher to normal operation.

Read and Follow the Deliming Cautions and Warnings  
on page 32 before deliming the machine..

## Deliming Procedure

Follow the procedures below to de-lime

1. Open the dishwasher door and remove any dish racks.
2. Turn the power switch on the dishwasher to the ON position.
3. Remove the detergent and rinse-aid chemical supply tubing from their chemical supply containers.
4. Place the tubing in a container of hot water
5. Press and hold the prime switch UP in the DETERGENT position to flush the detergent from the supply tubing. Release the switch.
6. Press and hold the prime switch DOWN in the RINSE AID position to flush the rinse-aid from the supply tubing. Release the switch.
7. Turn the dishwasher power switch to OFF/DRAIN to drain the wash tank. The green cycle light will go out in about 2 minutes.
8. Always wear eye protection, rubber gloves and protective clothing when handling chemicals. Open the door and carefully add the deliming chemical to the wash tank in accordance with your chemical supplier's instructions. Be careful to avoid splashing.
9. Close the door and press the EXT WASH/DELIME switch three times. The EXT WASH/DELIME indicator light will illuminate and the machine will run for 23 minutes.
10. Check the deliming results and if scale is still present repeat steps 7-9.
11. Push the power switch ON to refill the machine and return the dishwasher to normal operation.
12. Return chemical supply tubing to their containers and prime the chemical lines.

## Maintenance

Follow the maintenance schedules below to keep the dishwasher operating most efficiently.

### Daily Maintenance

1. Make sure the water supply is on and that the drain is not clogged.
2. Check the temperature gauges and/or displays to ensure they are operating.
3. Make sure the dish racks are in good condition.
4. Check the chemical containers and refill as required.
5. Follow the cleaning procedures provided in the Cleaning Section.

### Weekly Maintenance

1. Perform Steps 1-5 in the Daily Maintenance.
2. Inspect water lines for leaks.
3. Check for water leaks underneath the dishwasher.
4. Make sure the flexible water fill and drain hoses are not kinked.
5. Make sure that the dishwasher is level.
6. Clean accumulated lime deposits from the wash tank heating element.
7. Inspect the scrap screen and replace it if damaged.
8. Check the spray arms and replace or repair if damaged.

### Monthly Maintenance

1. Perform the Daily and Weekly Maintenance listed above.
2. Clean the chemical dispenser pick-up tubing for the chemical dispensing pumps.

To clean the pick-up tubing:

1. Remove the pick-up tubes from their containers.
2. Place each tube in a separate container of hot water.
3. Press and hold the PRIME buttons UP and DOWN until water flows into the wash tank compartment.
4. Return the pick-up tubes to their containers.
5. Run 3 empty dishwasher cycles to flush any chemicals from the dishwasher wash compartment.
6. Return the pick-up tubes to their containers and prime the chemical lines.

**NOTE:**

There are no lubrication points on the dishwasher.

# Troubleshooting

<u>Illustrations</u>	<u>Page</u>
Troubleshooting Chart	54
Wash Codes Temperature Display Board	55
Rinse Codes Temperature Display Board	56
Booster Codes Temperature Display Board	57
Timer Board Connection Diagram - All Models	58
Timer Board Diagnostic Testing	59
Temperature Display Board Power Terminal Connections	60
Temperature Display Board M3-M4 Selector Slide Switch	61
Temperature Display Board Diagnostics	62
Booster/Wash Tank Heater Interlock Circuit Operation	63

## Troubleshooting

Condition	Cause	Solution
Dishwasher will not run.	Door not closed. Main power OFF. Dishwasher OFF.	Close door completely. Check breaker on panel. Turn dishwasher power switch ON.
Low or no water.	Main water supply off. Fill hose kinked. Low incoming water pressure Solenoid valve defective. Solenoid strainer clogged. Circuit board fuse blown.	Open supply valve. Straighten fill hose. Set flowing water pressure to 20-22 PSI. Install repair kit or replace. Clean strainer. Contact service agent..
Chemicals won't feed into dishwasher.	Chemical supply low. Supply tubing damaged. Supply tubing kinked. Pick-up tube clogged Chemical circuit board fuse blown.	Refill chemical container. Replace tubing. Straighten tubing. Clean/replace tube. Contact service agent.
Low water pressure pumped from wash spray arms.	Clogged scrap screen. Clogged spray arms.  Clogged pump intake screen.	Clean scrap screen. Clean spray arms.  Inspect sump and clean pump intake screen.
Poor wash results.	Excessively hard water. Water temperature low.  Thermistor defective. (See chemicals won't feed above.) (See low or no water above.) Detergent injector defective.  Chemical circuit board fuse blown. Wares incorrectly loaded in dishrack.  Booster high limit tripped. Wash tank high limit tripped.	Contact chemical supplier. Raise incoming water temperature to 140°F Replace thermistor. (See chemicals won't feed above.) (See low or no water above.) Replace squeeze tube. Replace injector motor. Clean tubing and pick-up. Contact service agent. Reposition wares or reduce amount of wares in dish racks.  Reset or replace high limit. Reset or replace high limit.
Water has drained out of the wash tank while the dishwasher was idle.	Anti-siphon loop in drain hose has been removed. Drain hose clamp is not holding the drain hose in proper position. Building plumbing does not provide correct air vent to prevent siphoning.	Re-route drain hose. DO NOT STRETCH HOSE Replace/adjust hose clamp making sure goose-neck is maintained. Contact service Agent and/or plumber.
Dishwasher stays in wash cycle.	Incoming water supply cold Rinse Sentry extends wash mode for a maximum time of 5-minutes to allow final rinse water booster temperature to reach 180°F/82°C.  Dishwasher is operating in Extended Wash Mode.(UH230B, Only)	Raise incoming water temperature. Adjust/replace final rinse booster thermistor.  Push EXT WASH button to exit the Extended Wash mode.

## Digital Temperature Display Codes

Display codes that appear in the display windows indicate the operating condition of the machine. Refer to the illustrations below for the meaning of the codes.

### Wash Display Codes

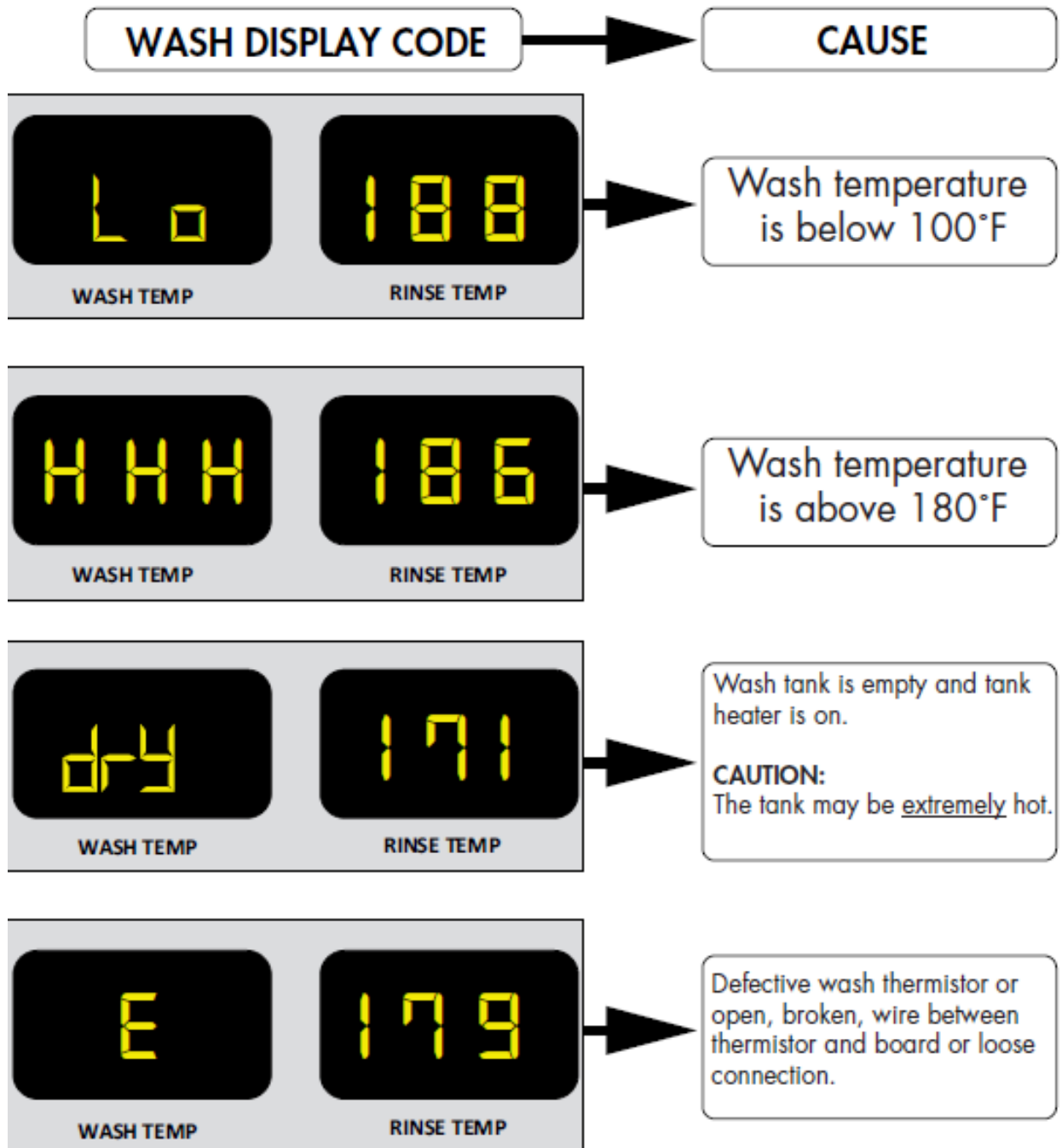

## Rinse Display Codes

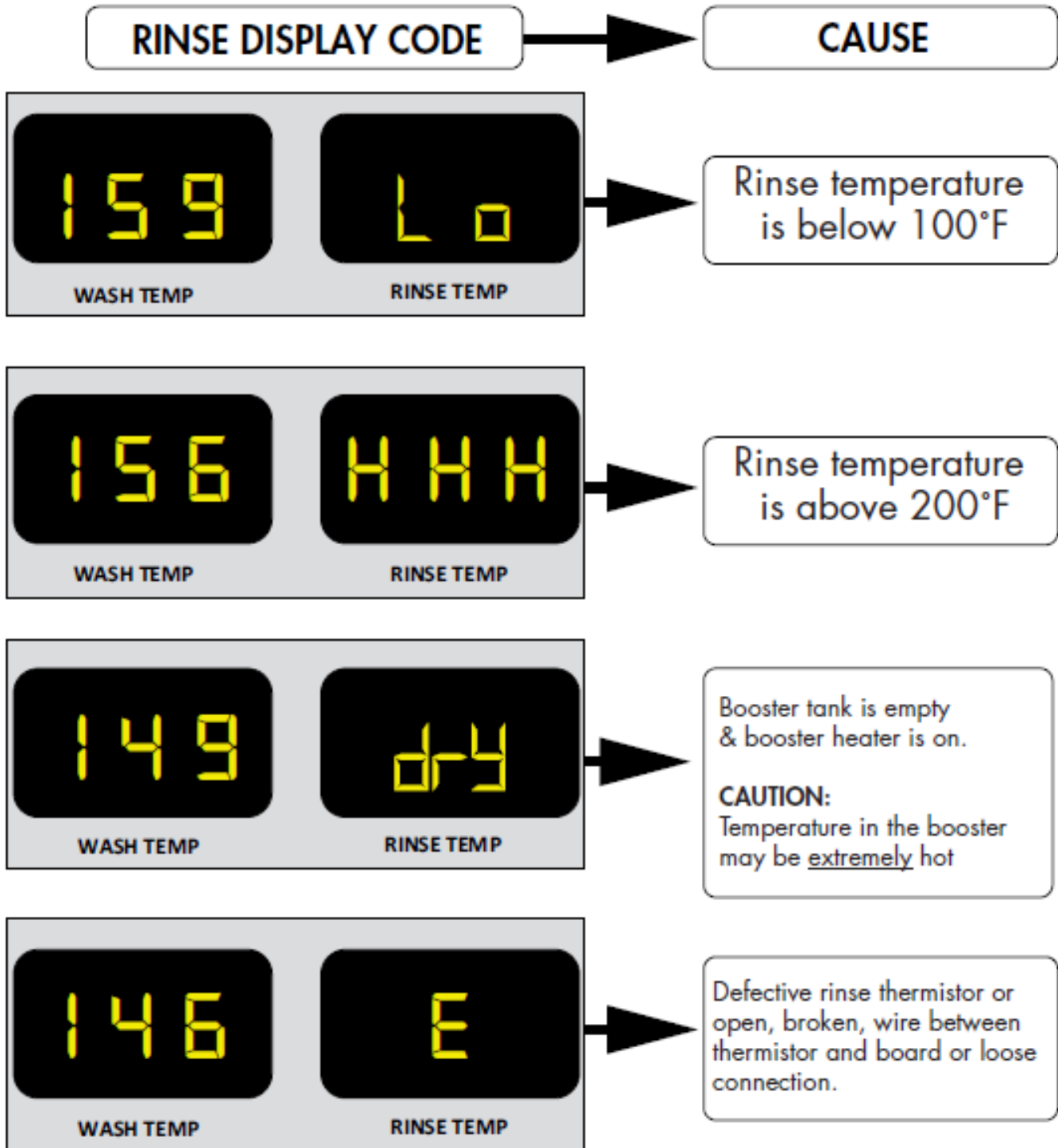

# Booster Display Codes

Error Codes for Booster and Final Rinse Thermistors Only.

DISPLAY CODES

CAUSE

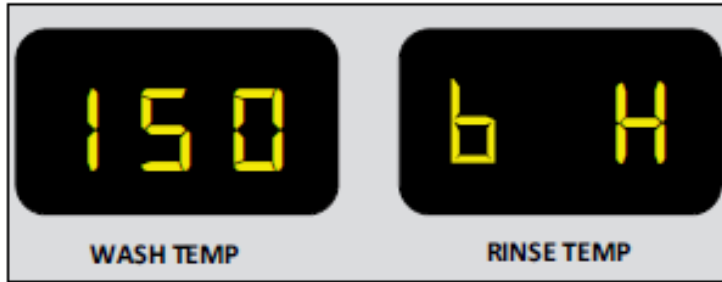

Booster overtemp lockout because booster temperature is greater than 210°F.

**NOTE:** Booster is locked out for 10 minutes before being re-energized.

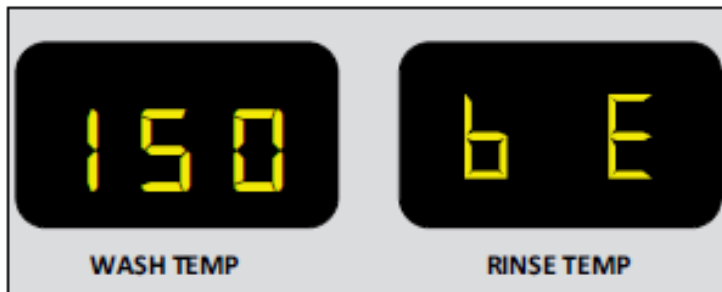

Booster thermistor is defective or disconnected, broken wires.

**NOTE:** After the thermistor is reconnected, there is a 5 second delay before the display is re-energized.

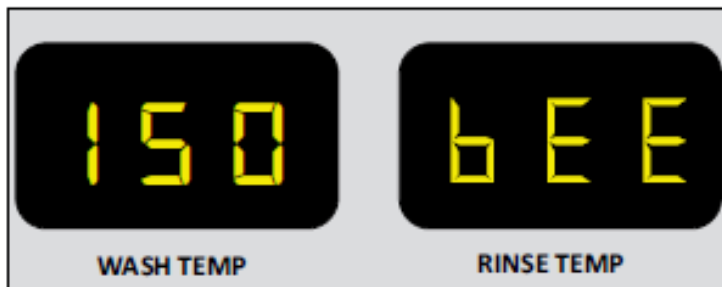

Both booster and final rinse display thermistors are defective, unplugged, or open or broken wires between the display and thermistor.

**NOTE:** After a thermistor is reconnected, there is a 5 second delay before the display is re-energized.

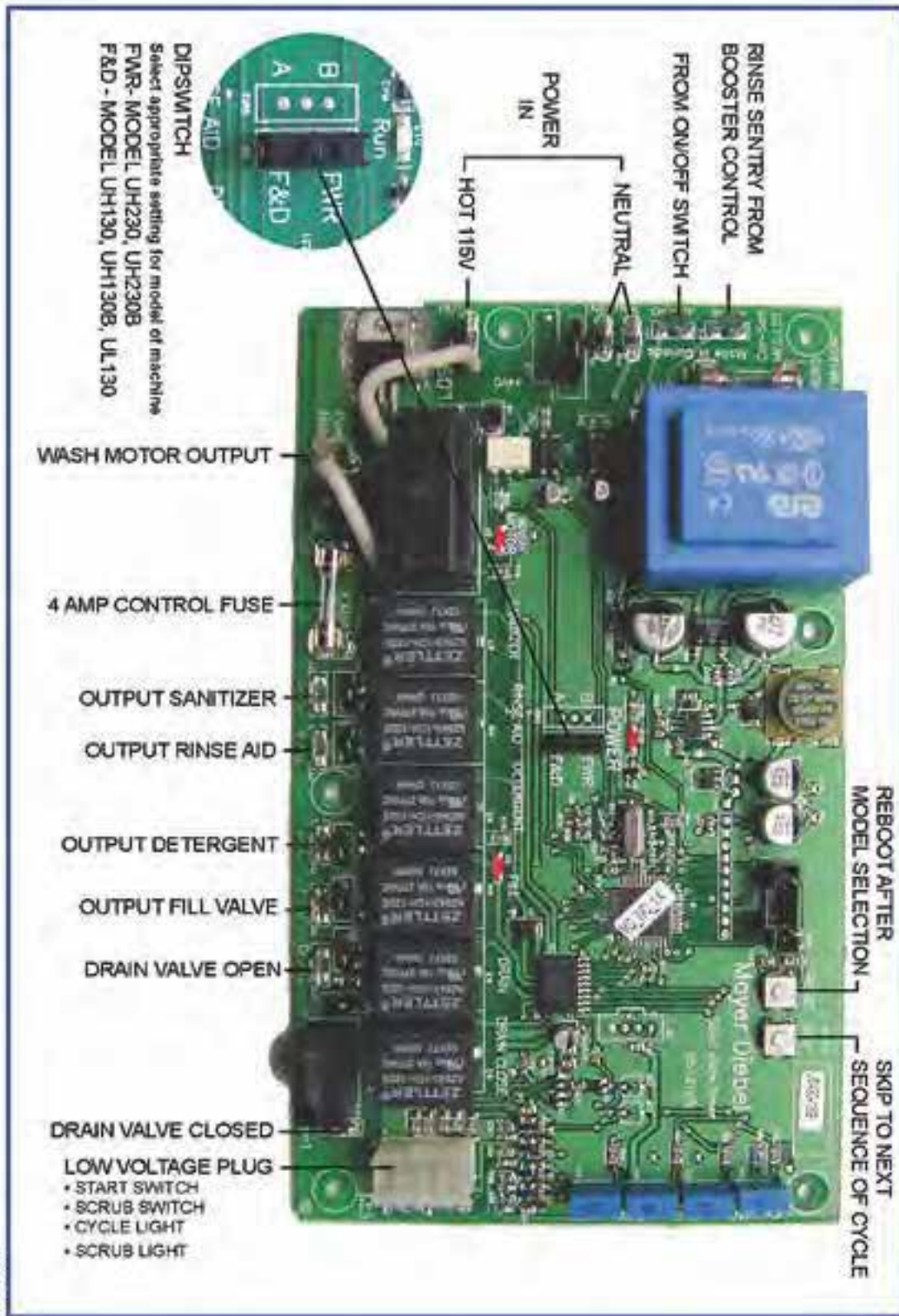

## Timer Connection Diagram

Solid State Timer P/N 0712105

January 2009

## Diagnostic Testing for the Solid State Timer Board, P/N 0712105

Beginning with S/N W081217467 and above

1

Before testing, Press the dishwasher power switch to OFF/DRAIN and allow the machine to complete the drain cycle.

Check the incoming voltages.

2

With the Power switch in the OFF/DRAIN position, press the START button 2 times.

If the drain valve opens and closes 5 times then the DRAIN VALVE is okay.

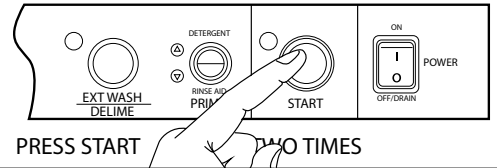

3

Open the door.

If the green cycle indicator light blinks continuously for 10 seconds, then the DOOR SWITCH and the CYCLE LIGHT are okay.

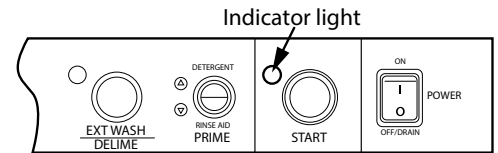

4

Press and release the START button.

If the green cycle indicator light flashes then the START BUTTON is okay.

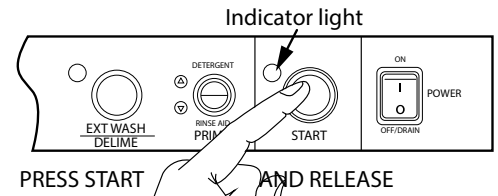

5

With the Power switch in the OFF/DRAIN position, press the START button 3 times.

The timer board and the following components are okay if the components run consecutively for a few seconds in the following order:

1. Fill Valve
2. Detergent Pump
3. Rinse-aid Pump
4. Drain Valve opens and then closes
5. Wash Pump
6. Drain Pump or Sanitizer Pump

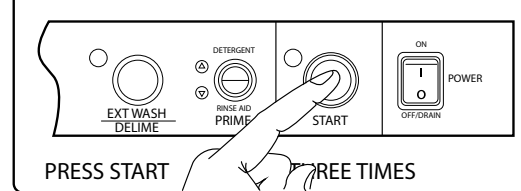

6

Troubleshooting - See below if one or more of the components in Step 5 did not run.

CONDITION	POSSIBLE CAUSE/SOLUTION
A single component in Step 5 does not run.	Check the component that did not run.
Wash pump only component that runs (Except UH330B, 601HT)	Check timer bd 4A fuse. (All except UH330B & 601HT)
Wash pump only component that runs (UH330B, 601HT ONLY)	Check timer bd 6A fuse. (UH330B & 601HT ONLY)
Wash pump only component that won't run. 4A/6A fuse okay.	Check pump/motor - see troubleshooting guide.
None of the components in Step 5 run.	Check neutral wire - see troubleshooting guide.

Undercounter Temperature Display Board — P/N 0512106 -1  
Power Terminals.

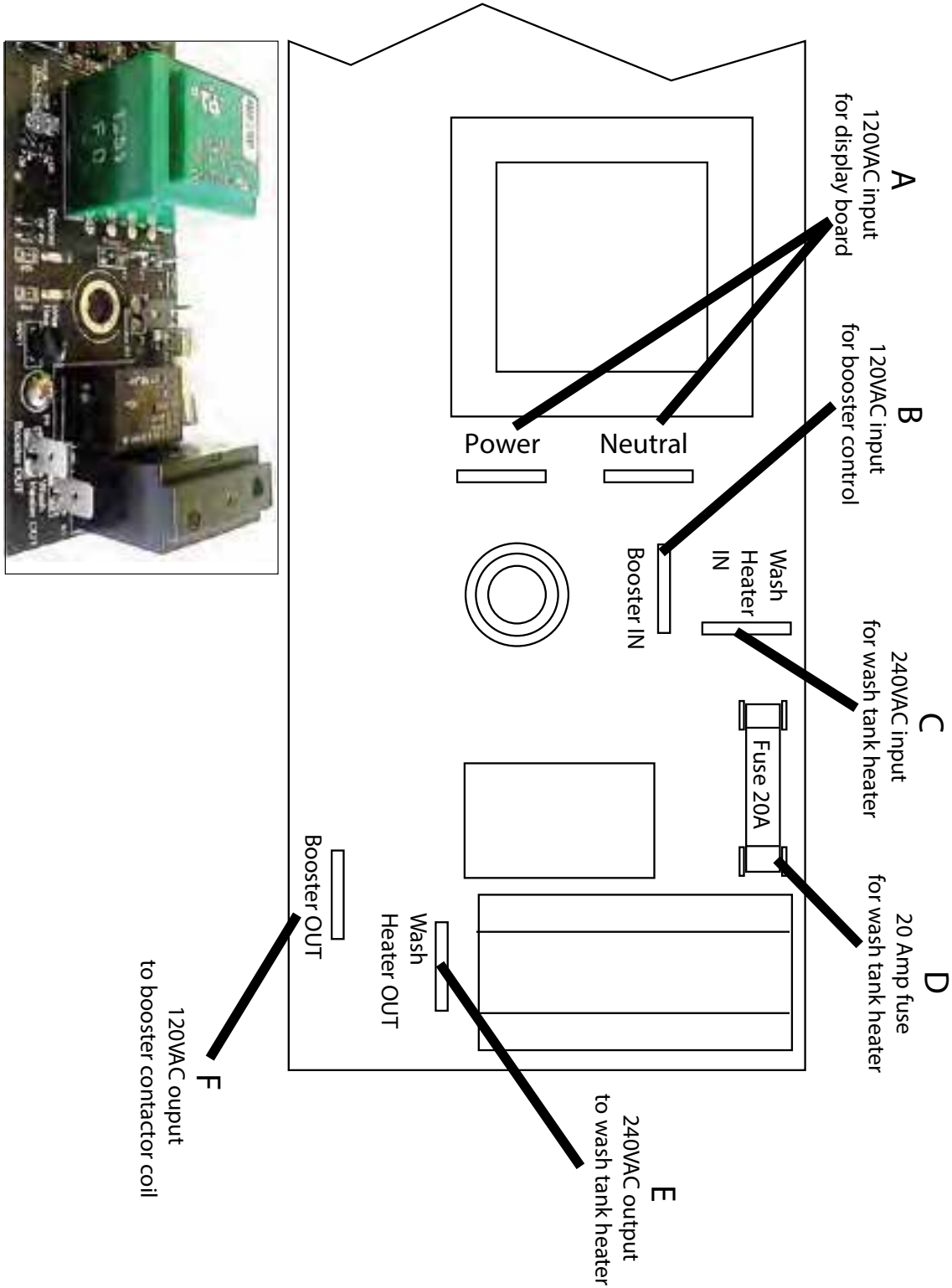

# UNIVERSAL TEMPERATURE CONTROL BOARD



REVA - 10-JAN-2018



## Power Up

When the board is powered up, it will do a self-diagnostic test, and then display; 1)The software version. 2) m4 mode. 3) Temperature units in F or C. 4) Wash and Rinse temperature pre-sets.



## Setting Temperatures

To adjust temperatures, push and hold the button of the target heat system. The display will begin to flash its temperature set point. Continue to push and release the button, and the available set points will scroll through the display. When you reach your desired temp set point, let go of the button, and the board will store the new setting.

RINSE TEMP ADJUSTMENT BUTTON

WASH TEMP ADJUSTMENT BUTTON

FAHRENHEIT OR CELSIUS SELECTOR BUTTON

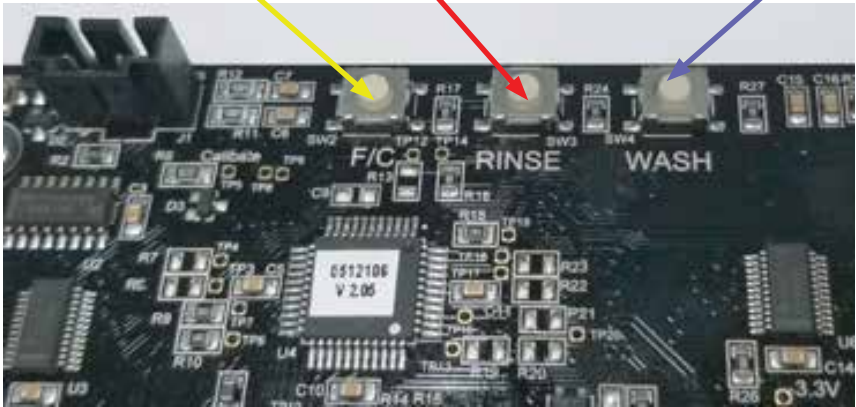

## Booster Heater/Wash Tank Heater Interlock Circuit Operation

The booster heater/wash tank heater interlock circuit removes power from the wash tank heater whenever the booster heater contactor energizes. The illustration below shows how the booster heater contactor is wired.

The booster heater contactor is located on the center of the base behind the lower front access panel.

### Interlock Circuit Operation

1. The dishwasher fills with water when the main power switch on the dishwasher is turned on. The booster heater thermistor calls for heat which energizes the booster heater contactor.
2. The auxiliary contact on the top of the contactor opens and removes power from the wash tank heater.
3. When the booster heater thermistor is satisfied, the booster heater contactor de-energizes and the auxiliary contacts close applying power to the wash tank heater.
4. This operation is repeated whenever the booster thermistor calls for heat.

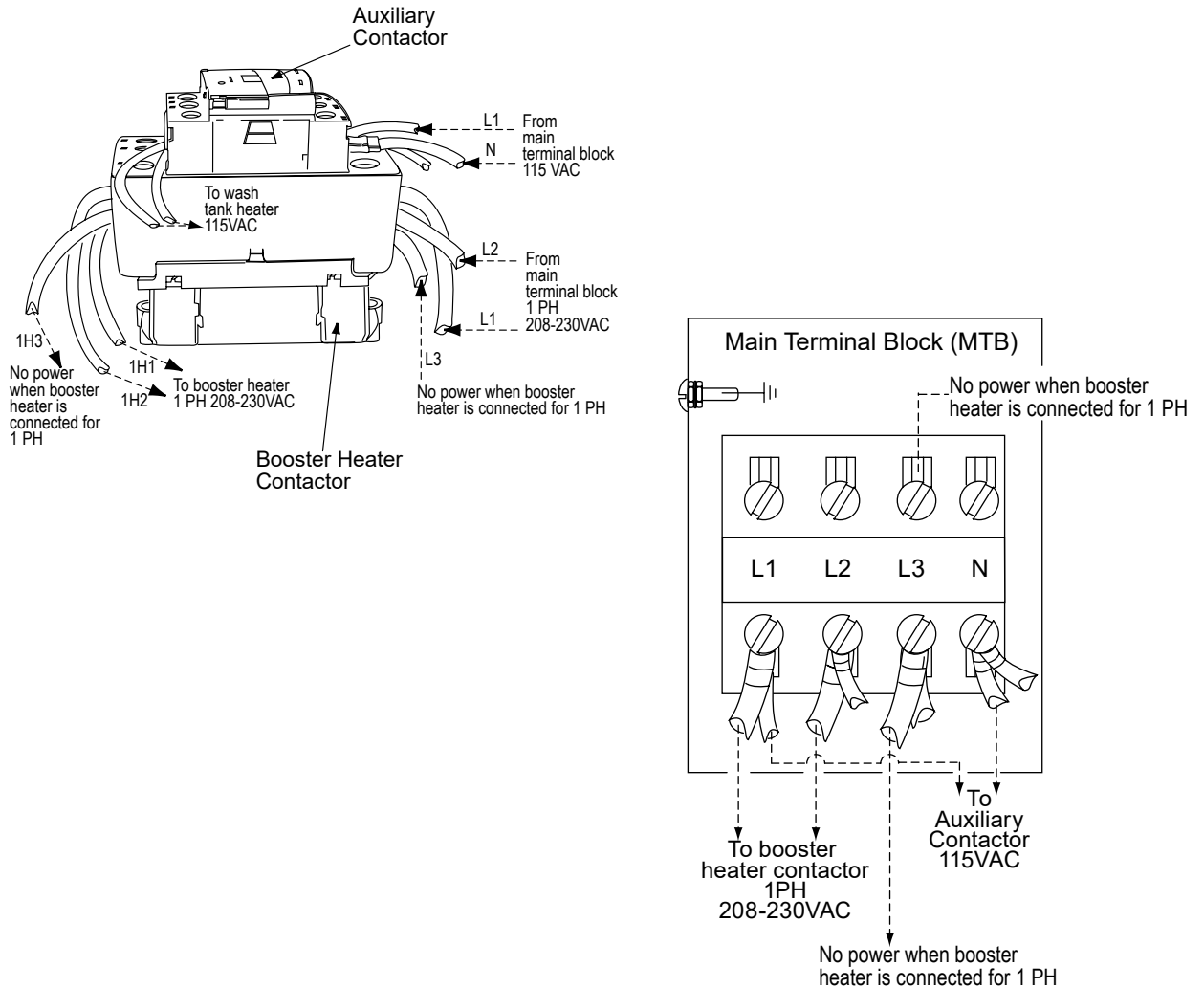

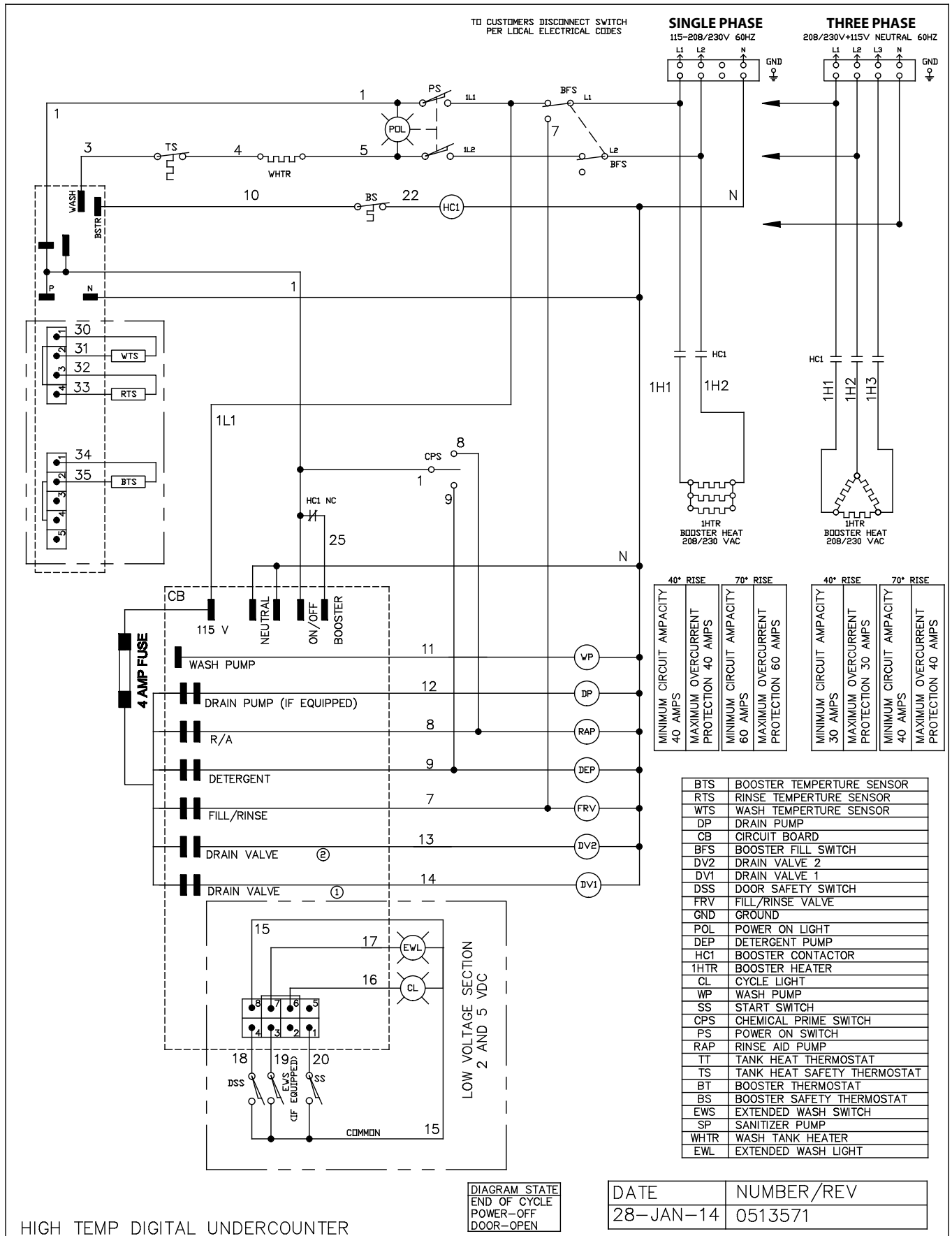

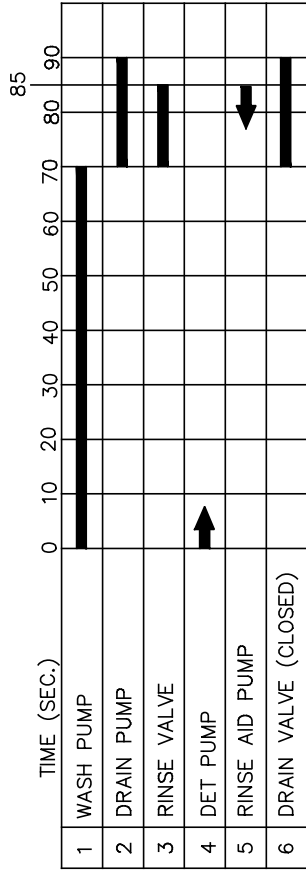
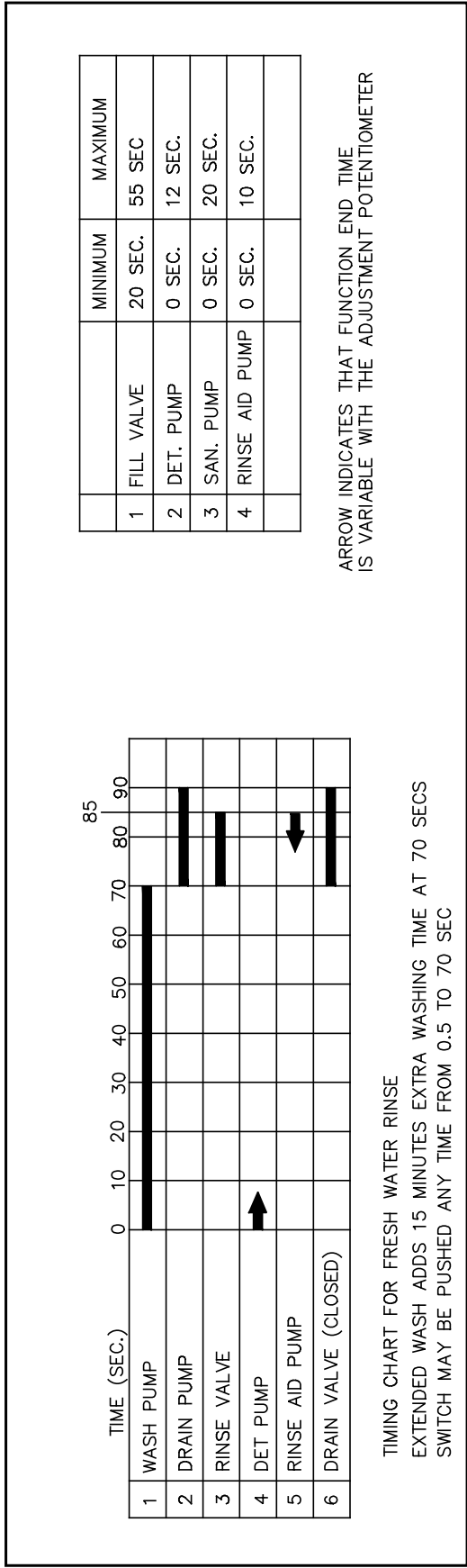

TIMING CHART FOR FRESH WATER RINSE  
 EXTENDED WASH ADDS 15 MINUTES EXTRA WASHING TIME AT 70 SECS  
 SWITCH MAY BE PUSHED ANY TIME FROM 0.5 TO 70 SEC

# Service Replacement Parts

Illustrations	Page
Wash Pump/Motor Assembly - All Models	2
Base Assembly - All Models	4
Fill Piping Assembly	12
Fill Rinse Piping Assembly	14
Final Rinse Piping	16
Fill Chute Assembly	30
Chemical Dispensing Pumps	32
Booster Assembly	38
Power Input Block and Cord Assemblies	40
Timer Control Board Assembly	42
Wash and Rinse Spray Arms and Drain Valve	44
Control Panel	48
Control Panel	50
Control Panel	52
Control Panel	54
Panels	56
Door Assembly	60
Dish Racks, Line Strainer, PRV	62

Wash Pump/Motor Assembly - All Models

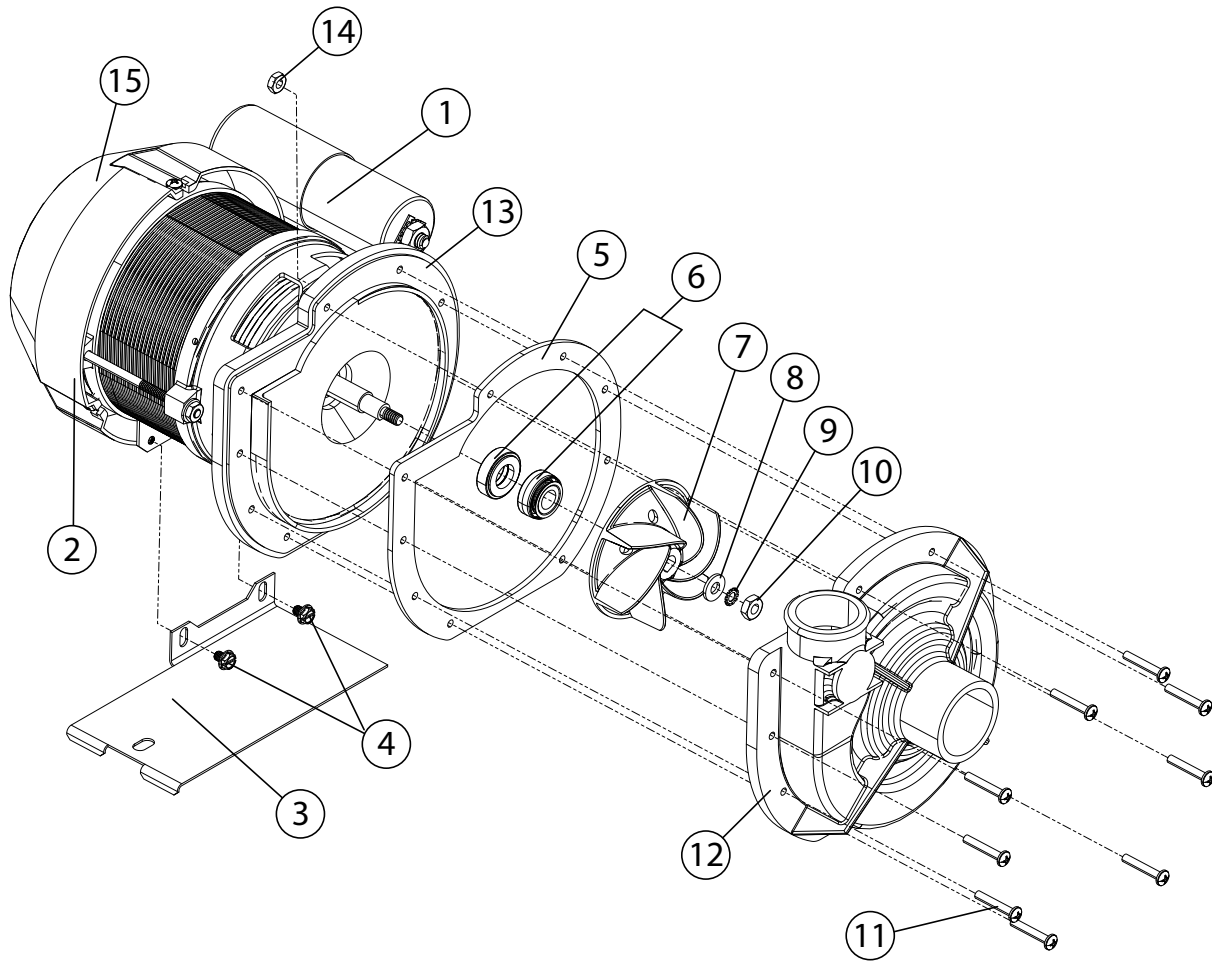

Item No.	Part No.	Description	Qty.
1	A0512347	CAPACITOR 40 $\mu$ F	1
2	A0512101	PUMP/MOTOR ASSEMBLY COMPLETE 115VAC/60/1	1
3	A0313394	BRACKET, WASH PUMP	1
4	A0512185	BOLT, HEX FLANGE 1/4-20 X 3/8" SST	2
5	A110285	GASKET	1
6	A114139	SEAL	1
7	A0512345	IMPELLER	1
8	A0501478	WASHER, PLAIN, 17/64"	1
9	A106482	WASHER, LOCK, 1/4"	1
10	A114144	NUT, M6	1
11	A0512340	SCREW, M4, PHIL, PAN HD.	9
12	A0512341	VOLUTE, PUMP	1
13	A114137	BACKPLATE, PUMP	1
14	A107337	NUT, M4	9
15	A0513131	COVER, REAR MOTOR FAN	1

NOTE: The pump motor is not sold separately.

Base Assembly - All Models

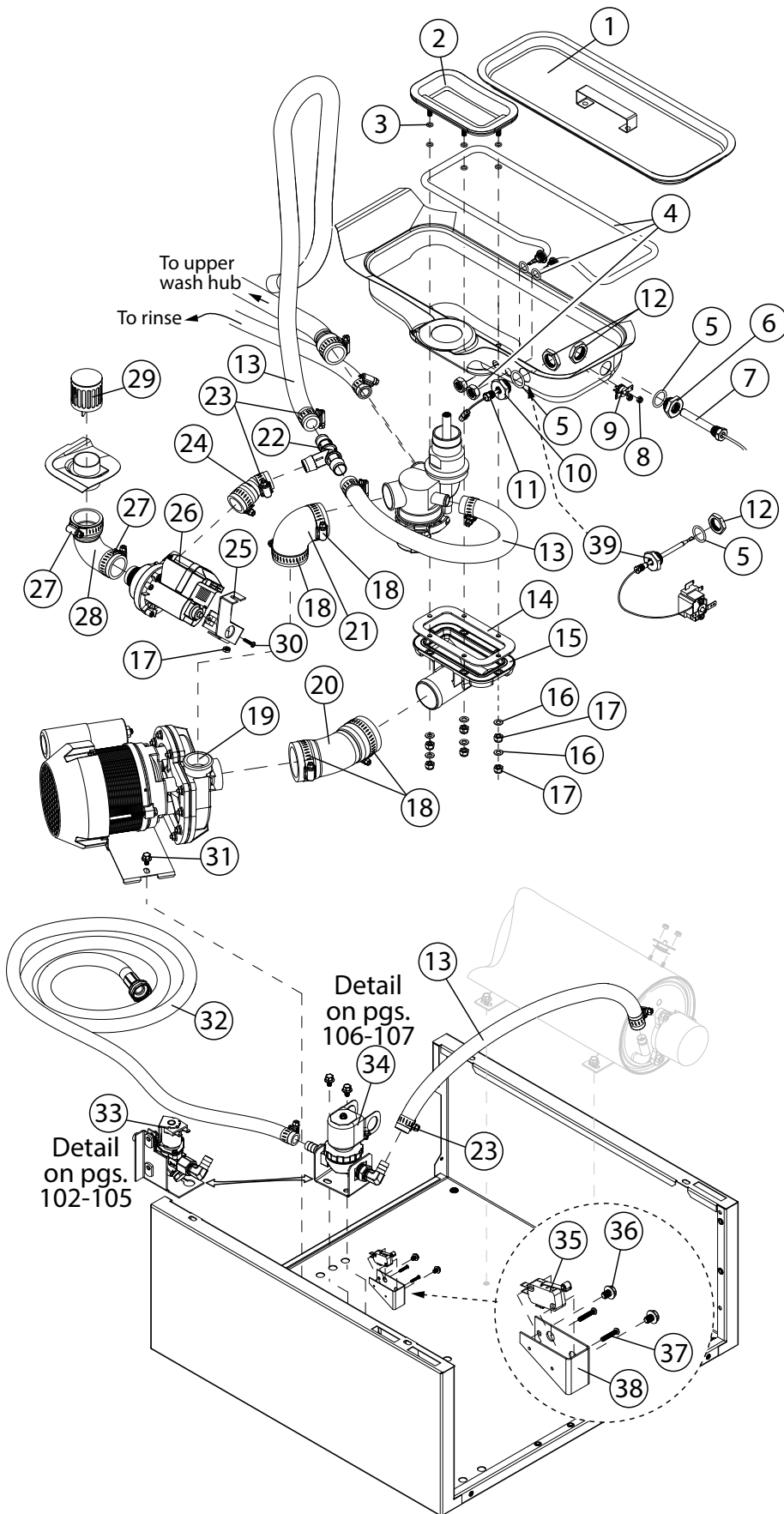

Item No.	Part No.	Description	Qty.
1	A0512136	SCREEN, SCRAP ASSY.	1
2	A0513324	FLANGE, PUMP SUCTION	1
3	A0513677	O-RING	A/R
4	A0512169	HEATER, 120VAC 750W)	1
---	A0512426	HEATER, 240VAC 2000W	1
5	A0512099	O-RING	1
6	A0508872	ADAPTOR, THERMOMETER	1
7	A0512107	THERMOMETER, WASH TANK	1
8	A108954	NUT, GRIP 6-32 WITH NYLON INSERT SST	2
9	A113604	THERMOSTAT, HI-LIMIT BI-METAL SNAP, 212°F	1
10	A0512299	ADAPTOR, THERMISTOR	1
11	A112612	THERMISTOR, 10 KΩ, 2 WIRE ASSY, WASH TANK	1
12	A201029-1	NUT, LOCK 1/2 INCH NI PLATED	A/R
13	A0509302	HOSE, 5/8" ID X 1" OD	A/R
14	A0513329	GASKET, PUMP SUCTION	1
15	A0513325	ELBOW, PUMP SUCTION	1
16	A0501476	WASHER	6
17	A107967	NUT, 1/4-20 W/NYLON INSERT SST	6
18	A0502571	CLAMP, HOSE 1-1/16" - 2"	2
19	A0512101	PUMP/MOTOR COMPLETE 115/60/1	1
20	A0513328	HOSE, PUMP SUCTION	1
21	A0512119	HOSE, PUMP DISCHARGE	1
22	A0512134	TEE, 3/4", POLY.	1
23	A0508808	CLAMP, SS GEAR	2
24	A0313171	HOSE, MOULDED 2-1/2"	1
25	A0312145	BRACKET, DRAIN PUMP	1

All Models - Base Assembly

Item No.	Part No.	Description	Qty.
26	A0512227	PUMP, DRAIN 115VAC	1
27	A0512322	CLAMP, HOSE	2
28	A0513339	HOSE, OVERFLOW	1
29	A0712236	TUBE, OVERFLOW GUARD	1
----	A0712236-1	TUBE, OVERFLOW GUARD	1
30	A109835	SCREW #8 X 1/2" SELF-TAPPING SST	1
31	A0512185	BOLT, HEX FLANGE 1/4-20 X 3/8" SST	1
32	A0509526	HOSE, 1/2" X 7 FT. FEM. GARD. ADAPT.	1
33	A0504952	VALVE, FILL 5.0 GPM	1
----	A0513557	VALVE, FILL 1.0 GPM	1
34	A109886	VALVE, SOLENOID, 1/2" NPT	1
35	A0501379	SWITCH, 15A	1
36	A0512792	SCREW, 10-32 X 1/4" RD. HD. PHILL. SST	2
37	A0508752	SCREW, 4-40 X 5/8" RH. HD. PHILL. SST	2
38	A0313432	BRACKET, DOOR SWITCH	1
39	A0507323	THERMOSTAT, WASH	1

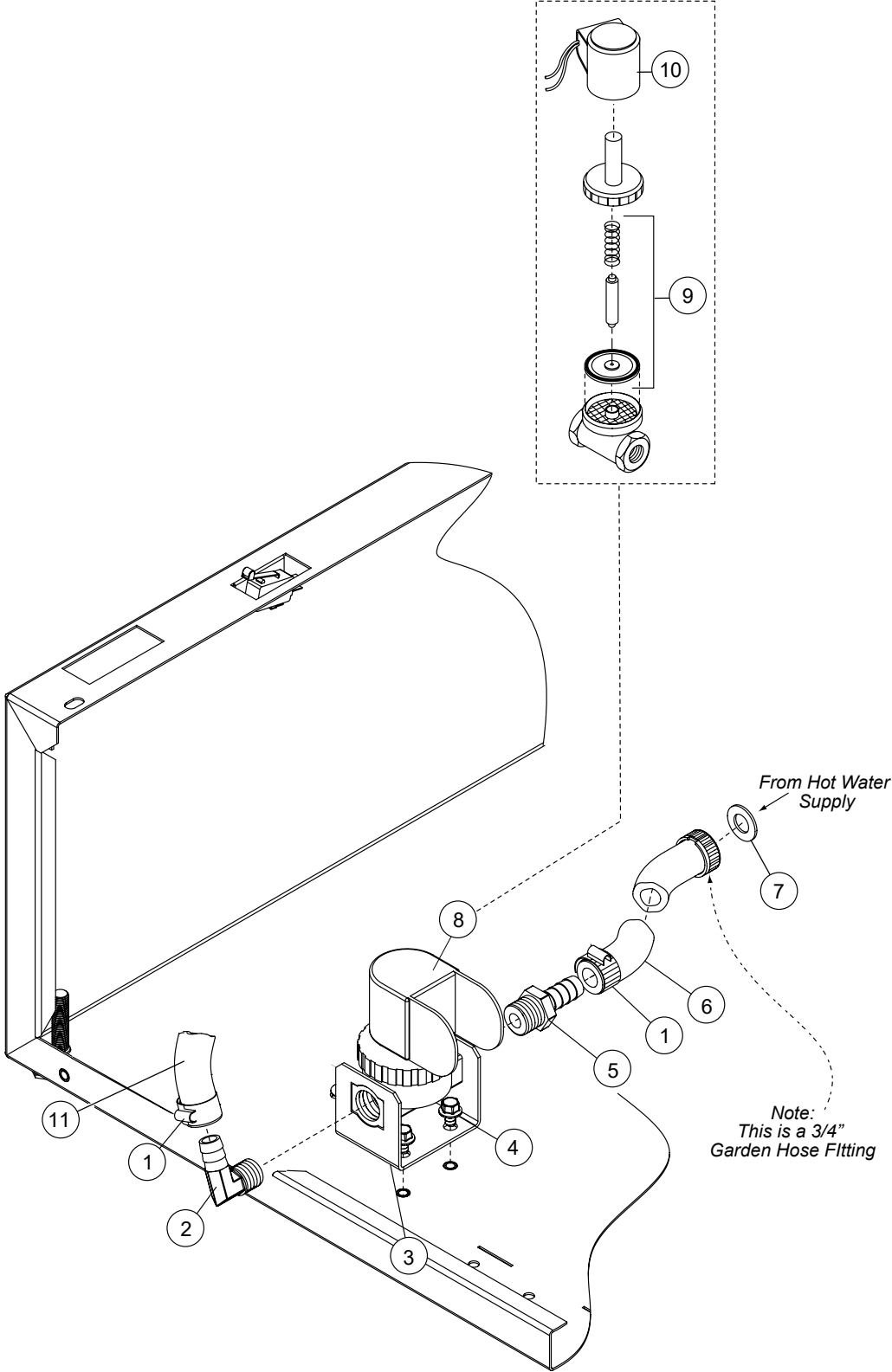

Fill Piping Assembly

Item No.	Part No.	Description	Qty.
1	A0512985	CLAMP, HOSE	2
2	A0508782	ELBOW, 90° 1/2" MPT X 1/2" HOSE	1
3	A0312146	BRACKET, 1/2" SOLENOID VALVE (UH230, UH230B)	1
4	A0512185	BOLT, HEX FLANGE 1/4-20 X 3/8" SS	2
5	A0502618	BARB, HOSE 1/2" X 3/8" MPT	1
6	A0509526	HOSE, 1/2" X 7 FT. FEM. GARD. ADAPT.	1
7	A0505320	WASHER, 1" OD GARDEN HOSE	1
8	A109886	VALVE, SOLENOID, 1/2" NPT 120VAC	1
9	A109902	KIT, REPAIR, 1/2" SOLENOID VALVE	1
10	A108516	KIT, REPAIR, COIL, 120VAC	1
11	A107417	HOSE, RUBBER 1/2" ID X .84" OD	A/R

# Upper Final Rinse Piping

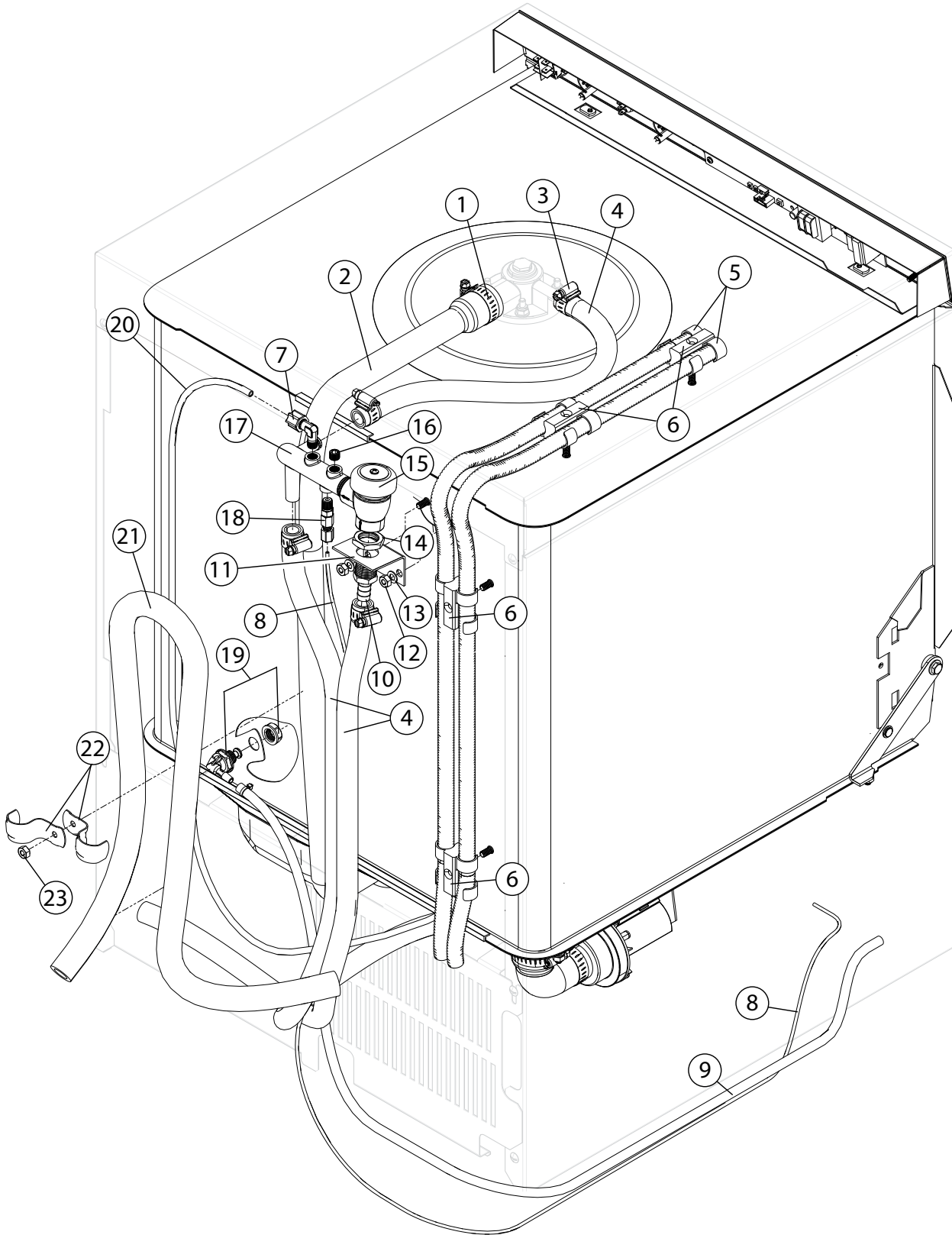

Item No.	Part No.	Description	Qty.
1	A0502571	CLAMP, HOSE	1
2	A0512120	HOSE, UPPER WASH	1
3	A0512985	CLAMP, HOSE	A/R
4	A107417	HOSE, RUBBER 1/2" ID X .84" OD	A/R
5	A0512757	CONDUIT, 1/2"	A/R
---	A0512758	CONDUIT, 3/8"	A/R
6	A0512369	CLAMP, CONDUIT	4
7	A112728	ELBOW, 1/8" MPT X 1/4" COMP PP	1
8	A112883-1	TUBING, 1/8" OD X 1/16" ID (RINSE-AID)	A/R
9	A0502667	TUBING, 1/4" ID X 3/8" OD (DETERGENT)	A/R
10	A0502651	COUPLER 1/2" MPT X 1/2" HOSE	1
11	A0312190	BRACKET, VACUUM BREAKER	1
12	A100003	NUT, HEX SST 1/4-20	2
13	A106482	WASHER, SPLIT LOCK 1/4" SST	2
14	A201029-1	NUT, LOCK 1/2" NICKEL PLATED	1
15	A100500	VACUUM BREAKER, 1/2" NPT, BRONZE	1
----	A900836	REPAIR KIT, VACUUM BREAKER 1/2"	1
16	A0508817	PLUG, 1/8" HEX COUNTERSUNK	A/R
17	A0513110	MANIFOLD, RINSE	1
18	A112763	FITTING, INJECTOR RINSE-AID	1
19	A0713656	KIT, DETERGENT FITTING	1
----	A110750	GASKET	1
----	A0513672	NUT, NP 1/4" NPS PP BLACK	1
20	A107928	TUBING, 1/4" NATURAL	AR
21	A0509302	HOSE, 5/8" ID X 1" OD	A/R
22	A107239	CLAMP, EMT	2
23	A107967	NUT, 1/4-20 W/NYLON INSERT SST	1

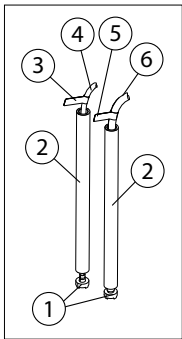

**IMPORTANT:**  
Check Items #9 and #10  
every 6 months and replace  
if stretched or worn.

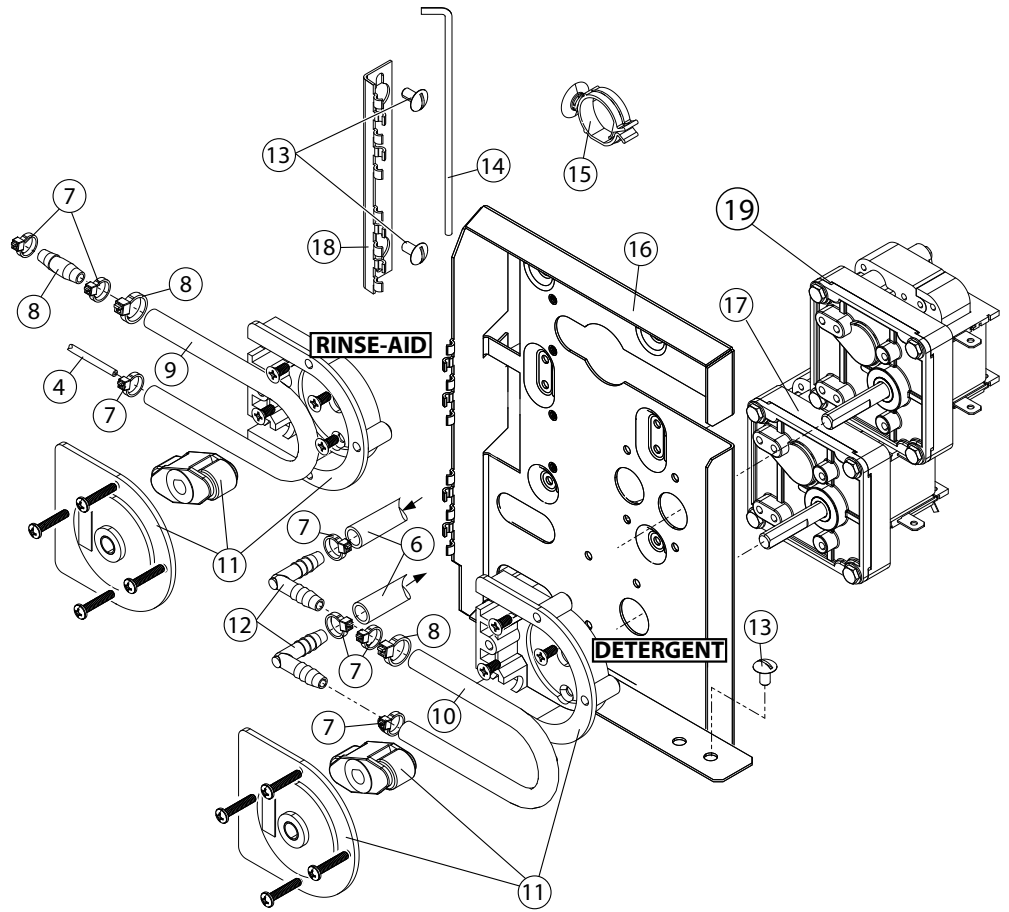

Chemical Dispensing Pumps

Item No.	Part No.	Description	Qty.
1	A0501869	STRAINER	2
2	A0306363	TUBE, 3/8" ID X 12" LG. STIFFENER	1
3	A0505483	LABEL, RINSE-AID HOSE	1
4	A112883-1	TUBING, 1/8" OD X 1/16" ID	A/R
5	A0503695	LABEL, DETERGENT HOSE	A/R
6	A0502667	HOSE, 1/4" ID X 3/8" OD PVC	A/R
7	A0501519	TIE, NYLON 4"	9
8	A0512369	CLAMP, HOSE	2
9	A112759	TUBE, PUMP 1/8" ID X 9" LG.	1
10	A114202	TUBE, PUMP 3/16" ID X 3/8" OD X 9" LG.	1
11	A114203	PUMP HD KIT, PERISTALIC	2
12	A0502644	ELBOW, 1/4" HOSE BARB	2
13	A100007	SCREW, 10-32 X 3/8" TRUSS SST	3
14	A0313644	PIN, HINGE	1
15	A0513645	HOLDER, CABLE	4
16	A0313393	BRACKET, CHEMICAL PUMP	1
17	A0510870-1	GEARMOTOR, 115/60/1, DETERGENT PUMP	1
18	A0313431	BRACKET, HINGED PANELS	1
19	A0510872-1	GEARMOTOR, 115/60/1, RINSE-AID PUMP	1

# Booster Assembly

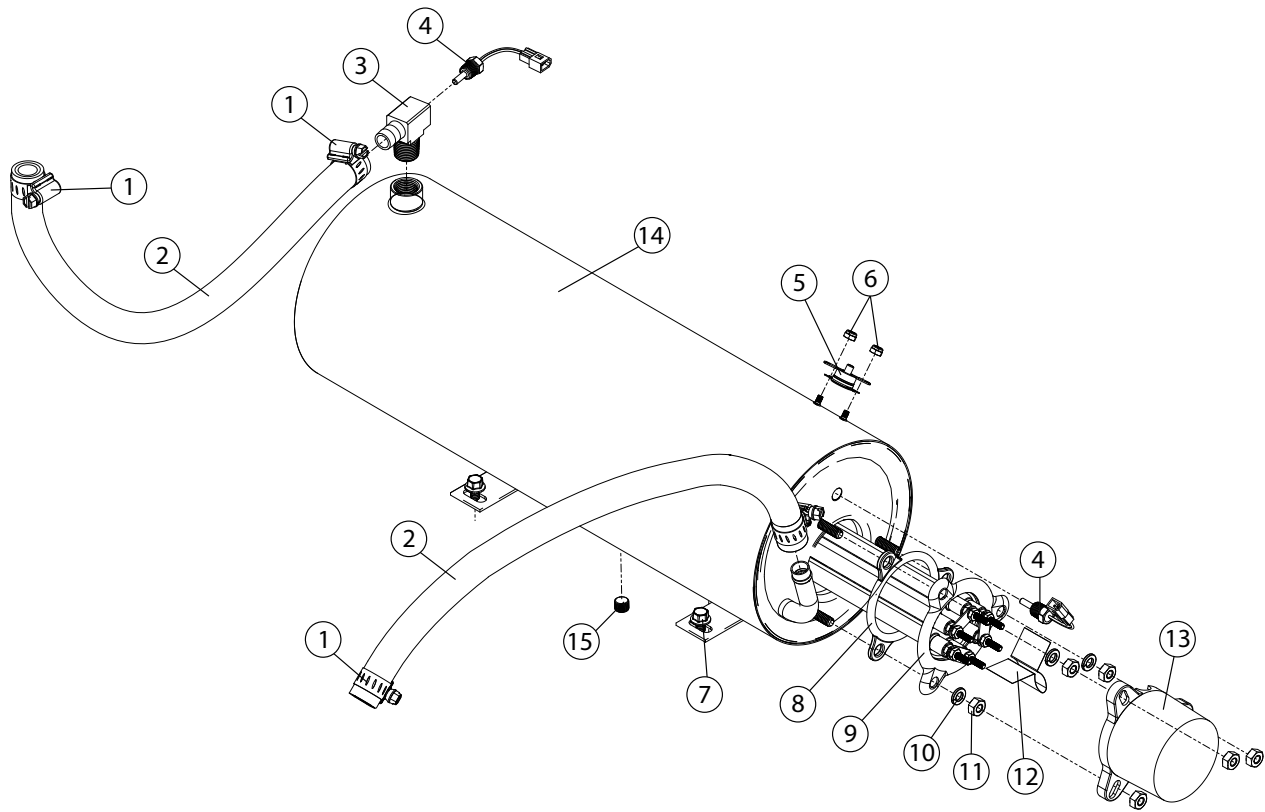

Item No.	Part No.	Description	Qty.
1	A0512985	CLAMP, SS GEAR-MIN. 1/2"	4
2	A107417	HOSE, RUBBER 1/2" ID X .84" OD	A/R
3	A0513314	TEE, RINSE	1
4	A0513310	THERMISTOR 10 kΩ, 2-WIRE	2
5	A110562	THERMOSTAT, HIGH LIMIT 240°F	1
6	A108954	NUT, GRIP 6-32 W/NYLON INSERT SST	2
7	A0512185	BOLT, HEX FLANGE, 1/4-20 X 3/8" SST	2
8	A109985	SEAL, BOOSTER ELEMENT	1
9	A111235-1	BOOSTER, ELEMENT 5 KW, 40°F RISE	1
---	A111233	BOOSTER, ELEMENT 9 KW, 70°F RISE	1
10	A106482	WASHER, LOCK 1/4" SPLIT SST	3
11	A100003	NUT, PLAIN 1/4-20 SST	6
12	A111885	INSULATOR	1
13	A107908	COVER, ELEMENT	1
14	A0713333	TANK, BOOSTER SST	1
15	A0508817	PLUG, 1/8"	1
----	A0513538	HARNESS, BOOSTER CONTROL (Not Shown)	1

# Power Input Block and Cord Assemblies

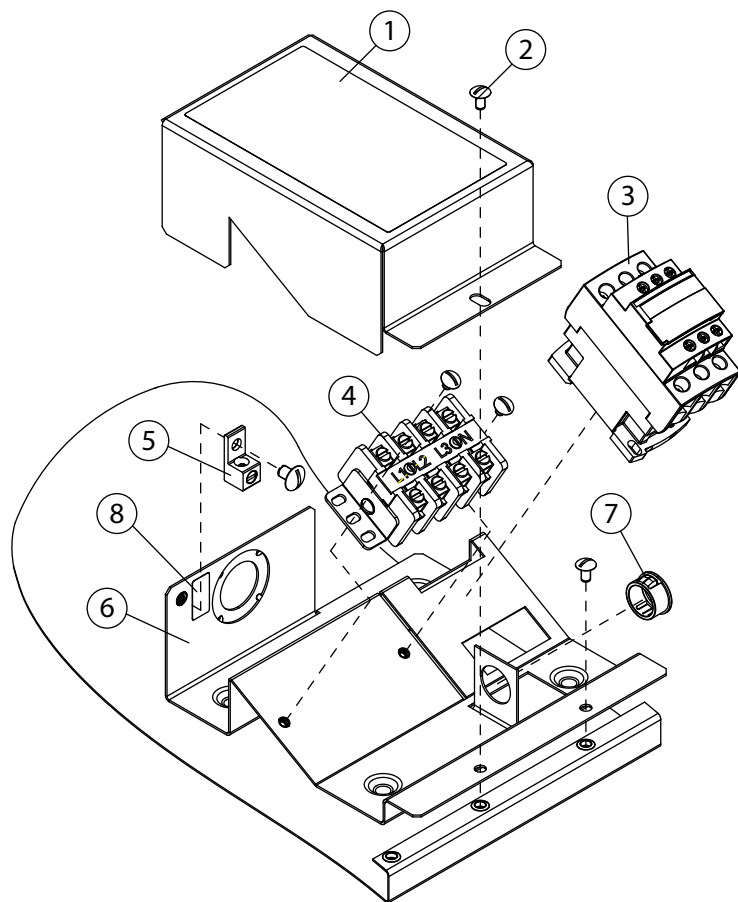

Power Input Block and Cord Assemblies

Item No.	Part No.	Description	Qty.
1	A0313396	COVER, BOX WIRING	1
2	A0501411	SCREW, 10-32 X 1/4", TRUSS HD.	2
3	A0512432	CONTACTOR, 3-POLE 120VAC COIL	1
4	A0509527	BLOCK, TERMINAL, 4-POLE (All except UL130)	1
5	A103310	LUG, GROUND	1
6	A0313395	BOX, WIRING	1
7	A107964	BUSHING, STRAIN RELIEF, SMALL	A/R
8	A0503592	LABEL, GROUND	1

# Timer Control Board Assembly

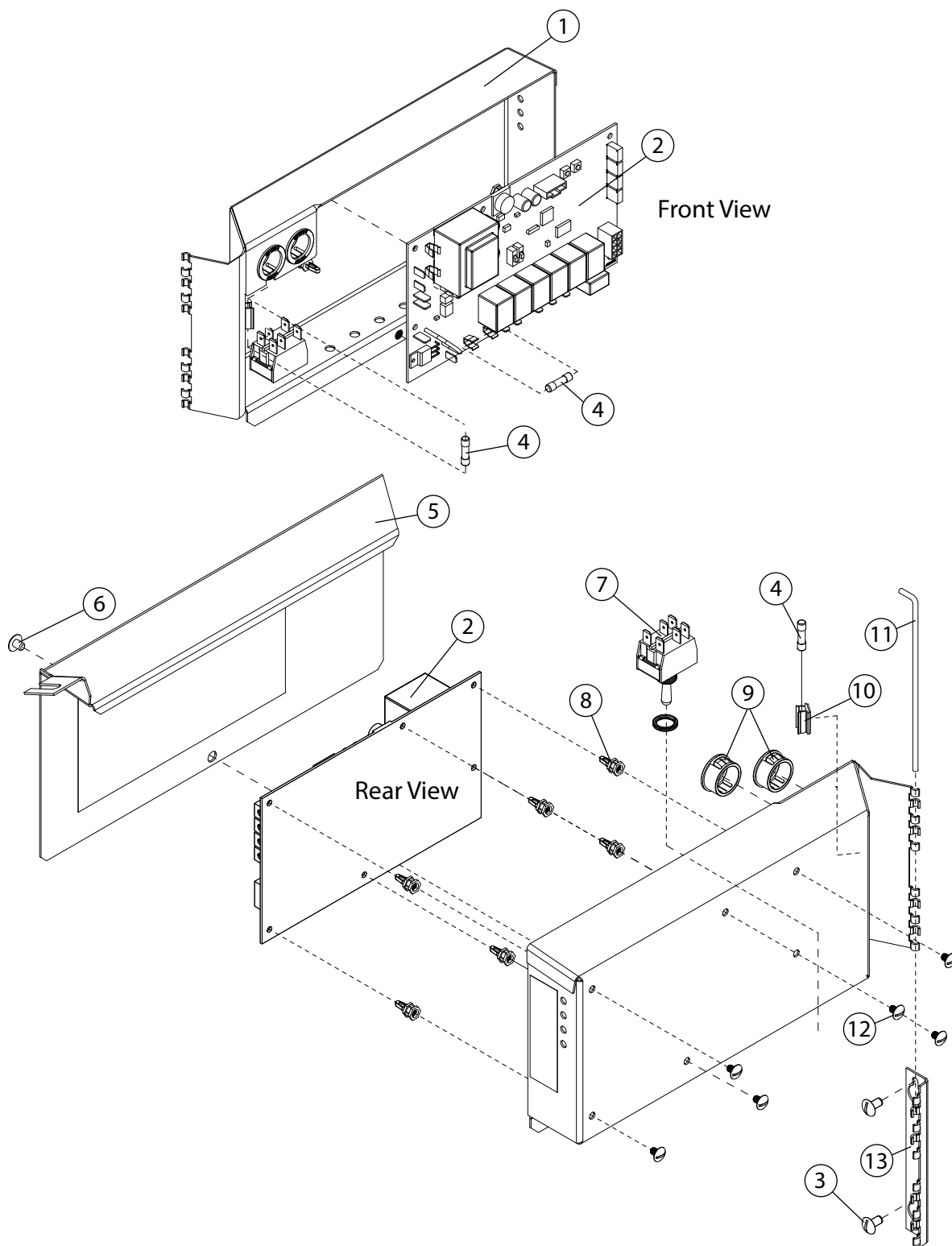

Item No.	Part No.	Description	Qty.
1	A0313397	BOX, CONTROL BOARD	1
2	A0712105	TIMER CKT. BD.	1
3	A0501464	SCREW, 10-24 X 3/8; TRUSS HD. SST	2
4	A0512373	FUSE, 4A 250V	1
---	A0513698	FUSE, 6A 250V	1
5	A0313398	COVER, BOX	1
6	A0501411	SCREW, 10-32 X 1/4" SST	1
7	A0501373	SWITCH, BOOSTER FILL	1
8	A0512973	STANDOFF	6
9	A107964	BUSHING, STRAIN RELIEF	2
10	A0512781	HOLDER, FUSE	1
11	A0313644	PIN, HINGE	1
12	A0501408	SCREW, 8-32 X 1/4" TRUSS HD. PHIL. SST	6
13	A0313431	BRACKET, HINGED PANELS	1

# Wash and Rinse Spray Arms and Drain Valve

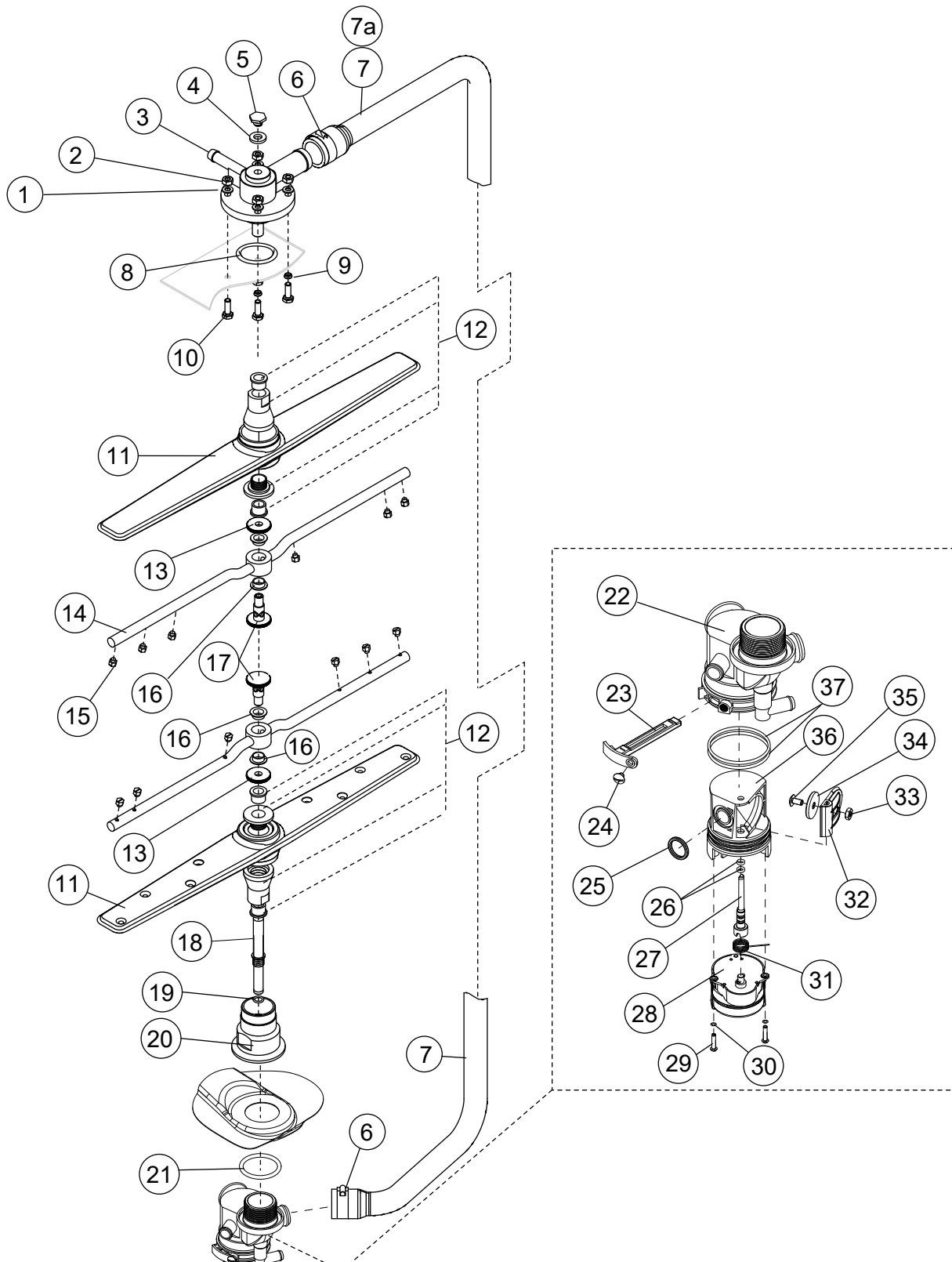

Wash and Rinse Spray Arms and Drain Valve

Item No.	Part No.	Description	Qty.
1	A0501478	WASHER, 17/64 id X 9/16" OD SST	4
2	A107967	NUT, HEX 1/40-20 NYLON INSERT SST	4
3	A0514251-1	HUB, UPPER SPRAY ARMS	1
4	A107873	WASHER, PACKING	1
5	A110215	SCREW, RETAINING	1
6	A0502571	CLAMP, HOSE GEAR 1-1/2" SST	2
7	A0512120	HOSE, UPPER WASH ARM (UH230, UH230B)	1
7a	A0513699	HOSE, UPPER WASH ARM (UH330B)	1
8	A0512133	O-RING, 2-1/8" OD X 1-3/4" ID X 3/16"	1
9	A0501481	WASHER, NYLITE	4
10	A100738	BOLT, 1/4-20 X 1" SST	4
11	AH420548	WASH ARM ASSEMBLY (Includes Item 12)	2
12*	A0712749	BEARING ASSEMBLY	2
13	AH34998	NUT, SPACER	2
14	AH36211	RINSE ARM ASSEMBLY (Includes Items 13, 16, and 17)	2
15	AH37149	NOZZLE, RINSE ARM	12
16	AH190663	BEARING, RINSE ARM	4
17	AH36275	SPINDLE, RINSE ARM	2
18	A0512124	SHAFT, LOWER	1
19	A0512239	O-RING	1
20	A0512066	HUB, LOWER WASH ARM	1
21	A0512133	O-RING, 2-1/8" OD X 1-3/4" ID X 3/16"	1
22	A0513439	HOUSING, MANIFOLD FWR	1
23	A0513443	PIN, RETENTION	1
24	A0509439	SCREW, RETENTION PIN 10-32 X 5/16" SST	1
25	A0513446	O-RING, QUAD	1
26	A0513445	O-RING, PIVOT SHAFT	2
27	A0513447	SHAFT, FLAPPER	1
28	A0712123	MOTOR, DRAIN VALVE	1
----	A0509257	PIN, MOTOR (COMES WITH MOTOR)	1
29	A104883	SCREW, MOTOR 6-32 X 3/8" SST	2
30	A0501497	WASHER, SPLIT LOCK #8	2
31	A0512126	SPRING, TORSION	1
32	A0513442	FLAPPER	1
33	A100194	NUT, FLAPPER SEAL 10-32 SST	1
34	A0512127	GASKET, FLAPPER	1
35	A100007	SCREW, FLAPPER SEAL 10-32 X 3/8" RD.HD. SST	1
36	A0513441	BODY, CARTRIDGE DRAIN VALVE	1
37	A0513444	O-RING, CARTRIDGE BODY	2
----	A0713667	CARTRIDGE ASSEMBLY, DRAIN VALVE COMPLETE INCLUDES ITEMS 23-37	1

\* Note:

The bearing assembly, P/N A0712749 includes 2 bearings, 1 locknut, and 1 wash arm hub. The bearings, locknut and hub are not available as separate service replacement parts.

# Control Panel

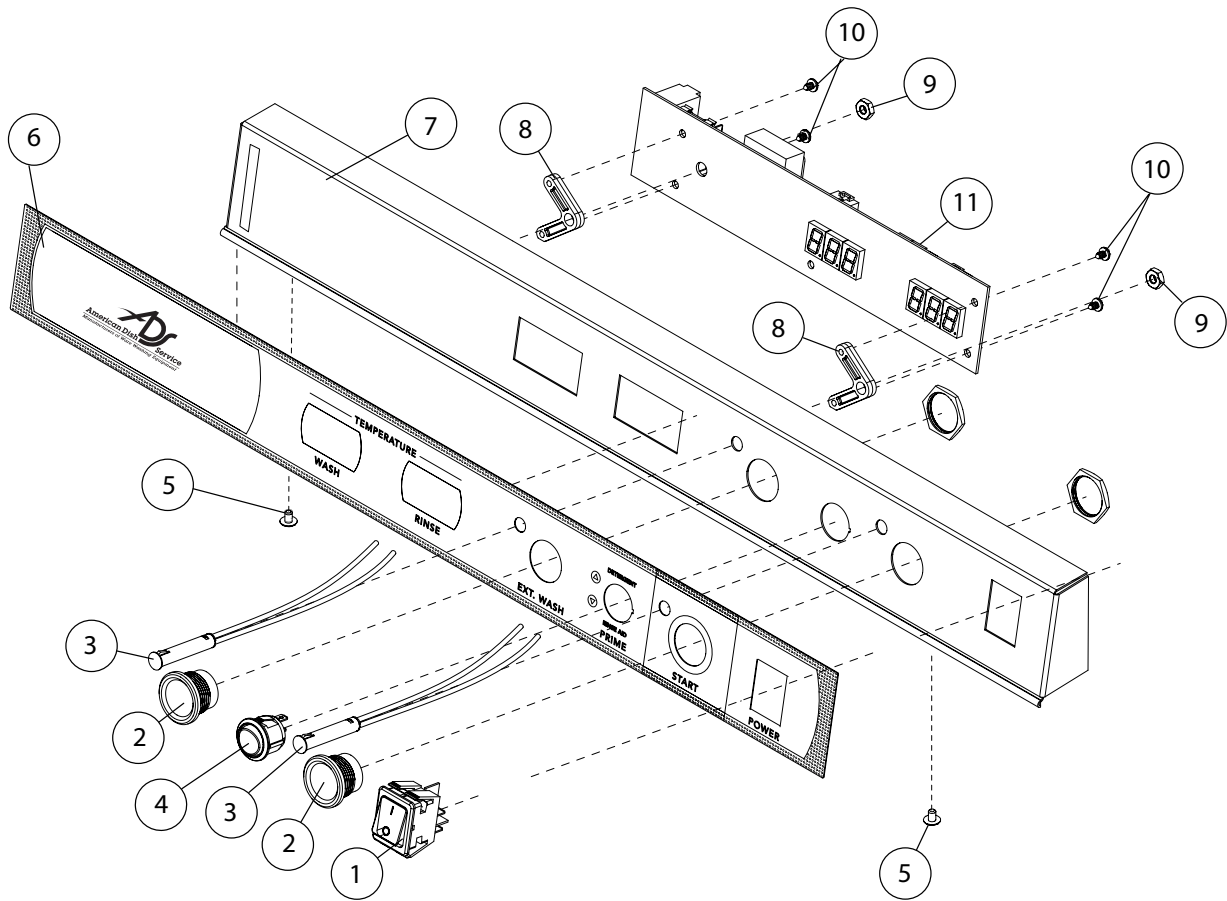

Item No.	Part No.	Description	Qty.
1	A0512221	SWITCH, ROCKER DPST 250V NEON	1
2	A0512213	SWITCH, PIEZIO	2
3	A0512232	LIGHT, INDICATOR, GREEN	2
4	A0512226	SWITCH, ROCKER RND SPDT MOMENTARY	1
5	A0501408	SCREW, TRUSS PHIL. SST 8-32 X 1/4"	2
6	A0513313	LABEL, FACIA ADS HUB-40 HIGH TEMP	1
7	A0313415	PANEL, FACIA	1
8	A0512357	STANDOFF, LED DISPLAY BOARD	2
9	A0503580	NUT, 10-32	2
10	A0501563	SCREW, #8 X 3/8"	4
11	A0712106	TEMPERATURE INDICATOR BD., DIGITAL	1
---	A0512362	HARNESS, DIGITAL DISPLAY (Not Shown)	1
---	A0513538	HARNESS, BOOSTER CONTROL (Not Shown)	1
--	A0513361	HARNESS, MACHINE (Not Shown) (Does not include Booster or Digital display harness)	1

# Panels

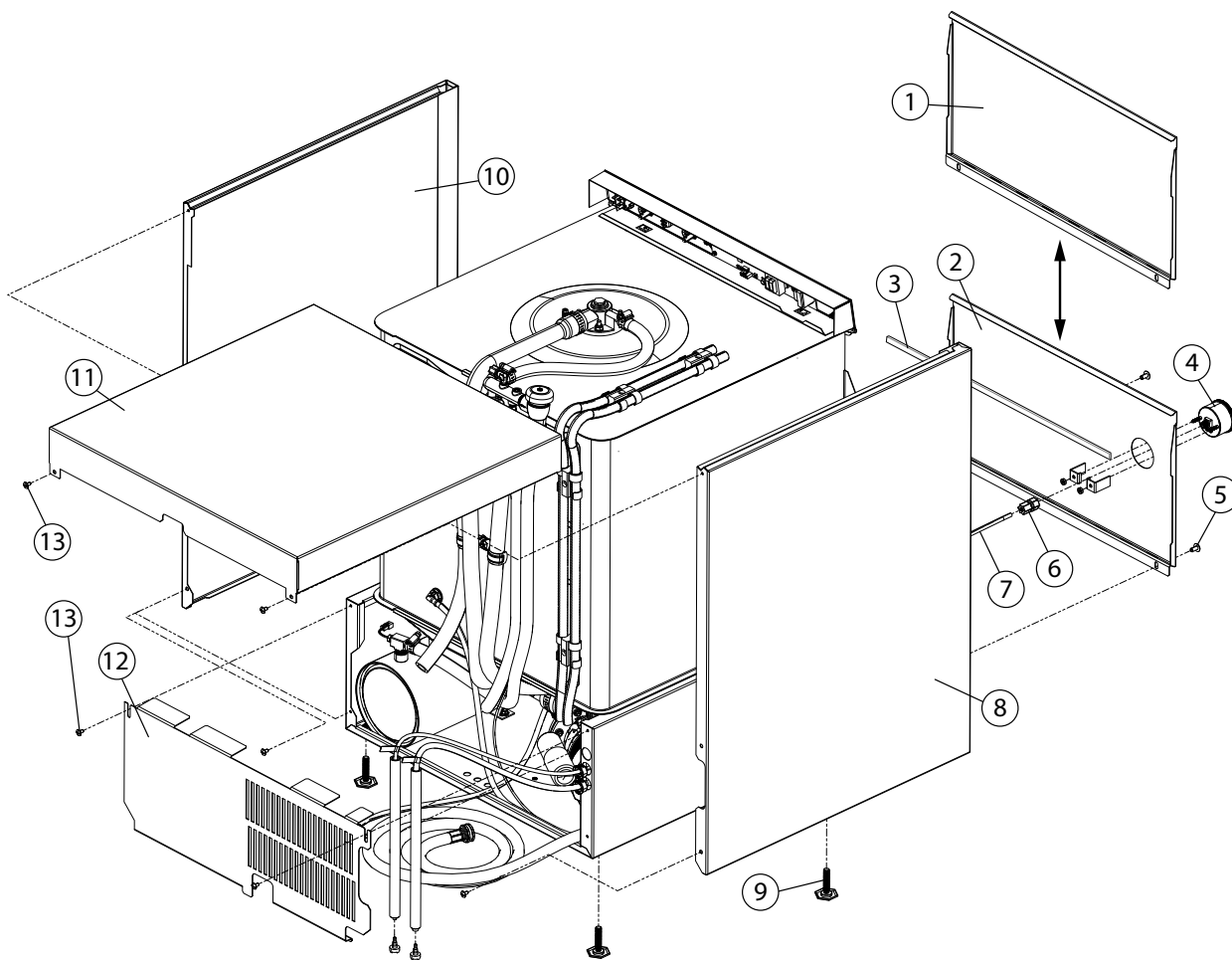

Item No.	Part No.	Description	Qty.
1	A0313406	PANEL, FRONT WITHOUT GAUGE HOLE	1
2	A0313407	PANEL, FRONT WITH GAUGE HOLE	1
3	A0512319	GASKET, 1/8" x 5/8" x 21-1/2"	1
4	A109812	GAUGE, PRESSURE 0-60 PSI	1
5	A100779	SCREW 1/4-20 X 5/8" TRUSS SS PHIL	A/R
6	A0513659	FITTING, 1/4" TUBE X 1/8" FNPT PP	1
7	A107928	TUBING, 1/4" NATURAL	A/R
8	A0313403	PANEL, LH SIDE	1
9	A0503718	FOOT, ADJUSTING	4
10	A0313402	PANEL, RH SIDE	1
11	A0313401	PANEL, TOP	1
12	A0313404	PANEL, REAR	1
13	A100007	SCREW, TRUSS SLOT SST 10-32 X 3/8"	A/R

# Door Assembly

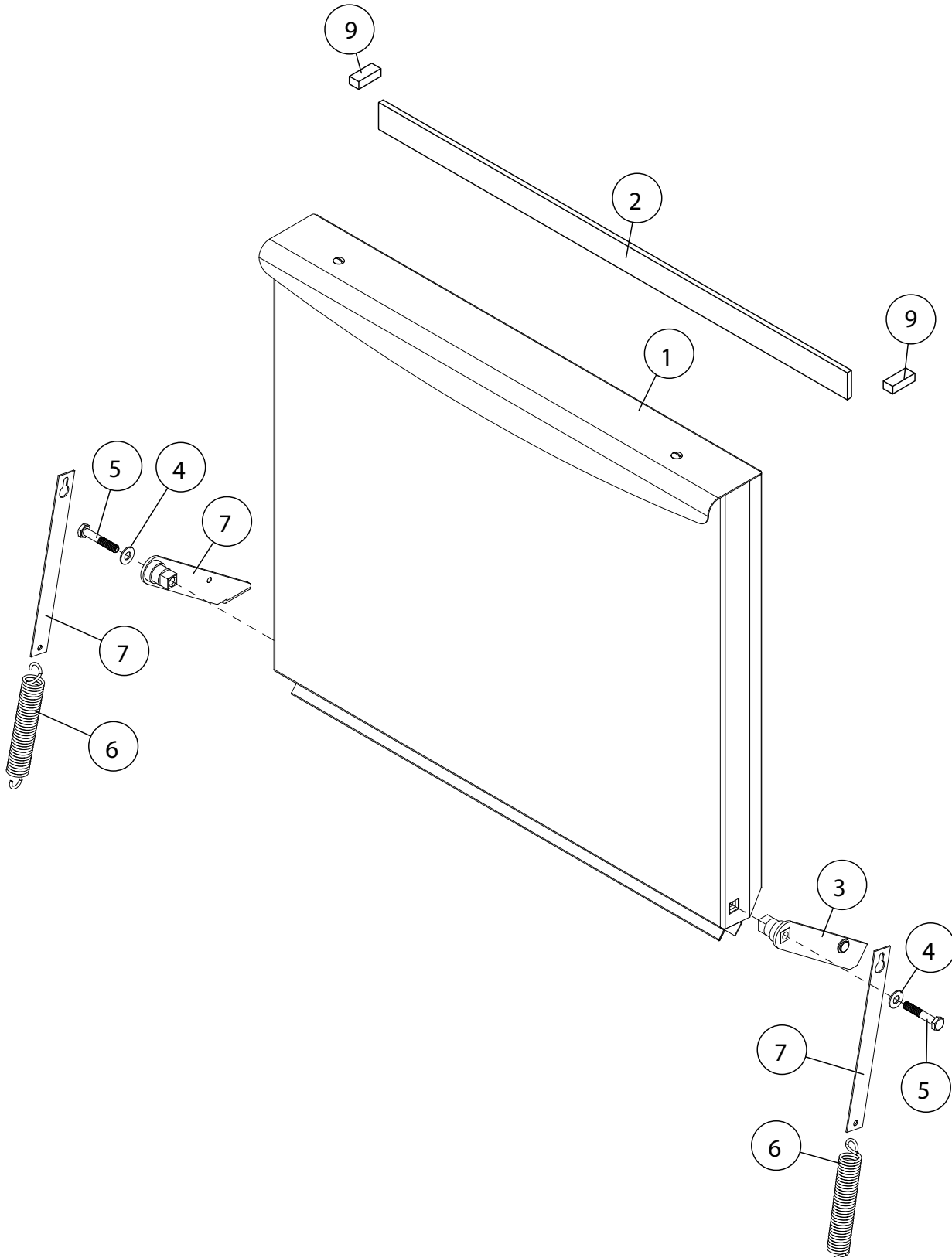

Item No.	Part No.	Description	Qty.
1	A0713136	DOOR ASSEMBLY	1
2	A0513558	GASKET, DOOR TOP	1
3	A0713428	HINGE, RH ASSY	1
4	A0501476	WASHER, 9/32" X 5/8" OD SS	1
5	A0501422	BOLT, HEX SS 1/4-20 X 1-1/2"	1
6	A0513332	SPRING, DOOR	2
7	A0713429	HINGE, LH ASSY	1
8	A0313430	ARM, DOOR SPRING	2
9	A0512320	GASKET, STEAM	2

Dish Racks, Line Strainer, PRV

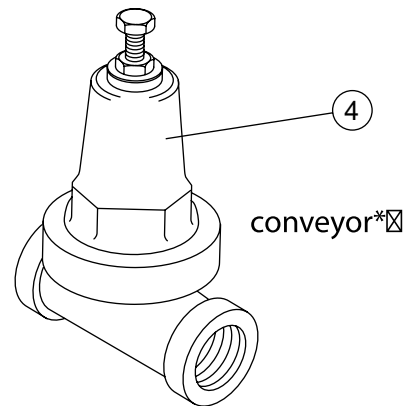
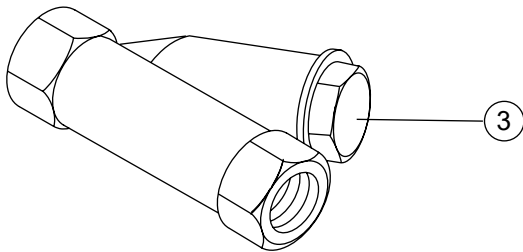
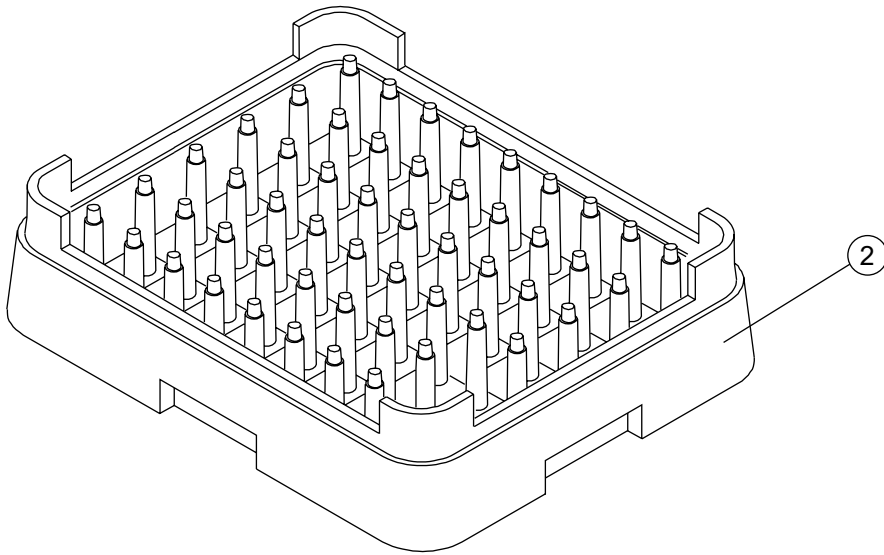
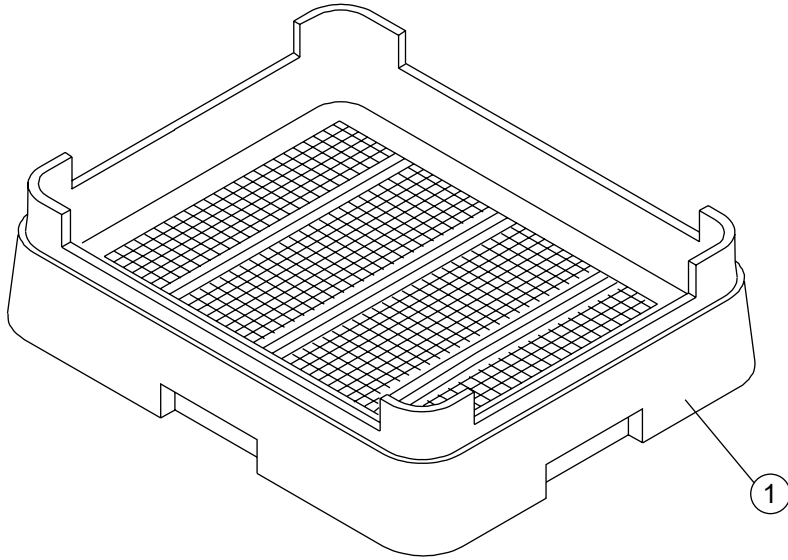

Item No.	Part No.	Description	Qty.
1	A101273	DISH RACK, FLAT-BOTTOM	AR
2	A101285	DISH RACK, PEG	AR
3	A104421	STRAINER, LINE 1/2" BRONZE	1
4	A108265	VALVE, PRESSURE REGULATING (PRV)	1

This Page  
Intentionally  
Left Blank