

INSTALLATION INSTRUCTIONS

Model L-90-3DW-S | L-90-3DWC-S

Available in 72 & 90-Second Time Cycles

Door-Type, Single-Rack, Chemical Sanitizer, Dump & Fill Dishmachine

Listed by UL #E68594, NSF/ANSI 3, ASSE 1004 #933, LA Test Labs File M-780089, Mass. License P3-0111-306



DANGER

The electrical power supplied to this machine is an imminent hazard that could result in severe bodily injury or death if not properly installed or hooked up correctly. When working in the control box or on electrical parts, always disconnect power and tag-out before servicing. Replace cover to control box and other protective covers when finished servicing this equipment.

© **American Dish Service**

900 Blake Street | Edwardsville, Kansas 66111
Phone: 913.422.3700 | Toll-Free: 800.922.2178 | Fax: 913.422.6630
orders@americandish.com | americandish.com

If you have questions, call 800-922-2178 or
visit our website at
www.americandish.com



CAUTION

Read manufacturer's manual before using this product. For your safety read and observe all cautions shown throughout these instructions. While performing installations described in this booklet, wear approved personal protective equipment, including safety eye-wear.

CHEMICALS—There are potentially hazardous situations when working with industrial cleaning chemicals for dishmachines. See chemical manufacturer's safe practices and SDS sheets for handling and installing chemicals and supply containers.



WARNING: Cancer and Reproductive Harm – www.P65Warnings.ca.gov

NOTICE

#1 BEFORE YOU BEGIN—American Dish Service provides this information as a service to our customers. Keep all instructions for future reference. ADS reserves the right to alter or update this information at any time. Should you desire to make sure that you have the most up-to-date information, we would direct you to the appropriate document on our web site: www.americandish.com. Set out below are the specifications and requirements that you must use and follow to properly install the type or types of equipment listed above. It is your obligation as the customer to ensure that the machine is installed safely and properly, and when completed, the machine is left in proper and safe working order. Electrical, Plumbing, and Chemical hookup should be performed by a qualified professional who will ensure that the equipment is installed in accordance with all applicable Codes, Ordinances, and Safety requirements. Failure to follow the installation instructions could void the warranty. ADS assumes no liability or control over the installation of the equipment. Product failure due to improper installation is not covered under the ADS Warranty.

#2 FLUSH OUT—Do not install spray arm until machine is flushed with water. When this machine is turned on, first fill by pushing and holding the button marked FILL until water inside the pan reaches the water level decal on the outside of the pan, then push the button on front door marked START to complete one cycle. Do this before installing the spray arm. Dump the flush water out before installing spray arm by pushing the button marked DRAIN. Draining the water will flush installation debris from the tank and pump; this prevents damage to the spray arm bearing.

#3 WATER HEATERS—or boilers must provide the minimum temperature of 120°F required by the machines listed above, which have a minimum demand of 60 gallons per hour. The recommended temperature range for optimal performance is 130–140°F. These specifications are for the dishmachine only, which typically accounts for 70% of a restaurant's hot water demand.

#4 IMPORTANT—The models of dishmachine listed in this document must be installed with space around the outside to allow for servicing of the motor as well as a 4" space behind the machine from the wall. It should not be built into wooden cabinets.

#5 INSPECT FOR DAMAGE—If you receive a damaged dishmachine, do not sign “Clear” but write “damaged” on the documents.

#6 LOOSE ELECTRICAL CONNECTIONS—Damage to equipment can occur if the following precautions are not observed. Before connecting power to the machine, check all electrical terminals in the control box. Screws can loosen in transit. Loose connections on high amp load terminals such as the pump motor will cause wire burning and component damage during operation and will not be covered under ADS warranty.

#7 “CLEAN CIRCUIT” means the electrical circuit breaker for the dishmachine supplies no other outlets, machines, or lights. GFCI outlets are not recommended for commercial dishmachines; ADS recommends that a single-rack machine be installed with the wire connection (hard-wired) directly from the circuit breaker. If a plug and socket are used to provide electrical power to a dishmachine in a commercial kitchen, then according to electrical code it must be a GFCI, but not all GFCIs are the same. They must be rated for the draw of the circuit.

Reference NEC Article 210.8 GFCI Protection (B) Other Than Dwelling Units (2) Commercial and Institutional Kitchens. All 15 and 20A, 125V receptacles installed in kitchens, even those that do not supply the countertop surface, must be GFCI protected.

#8 This equipment is considered an item of heavy use. It is not rated for outdoor use.

ELECTRICAL SECTION



The electrical power supplied to this machine is an imminent hazard that could result in severe bodily injury or death if not properly installed or hooked up correctly

Electrical: L-90-3DW-S or L-90-3DWC-S (120 volt, 20 amp)

Time cycles of 90- or 72-seconds are available for this model and are compliant with NSF listing. The model number would appear as L-90-3DW-S or L-72-3DW-S. The “C” identifies the machine as a corner model. To change to a shorter time cycle, the entire cam timer assembly must be changed because of motor gearing.



Showing control tray installed in normal position

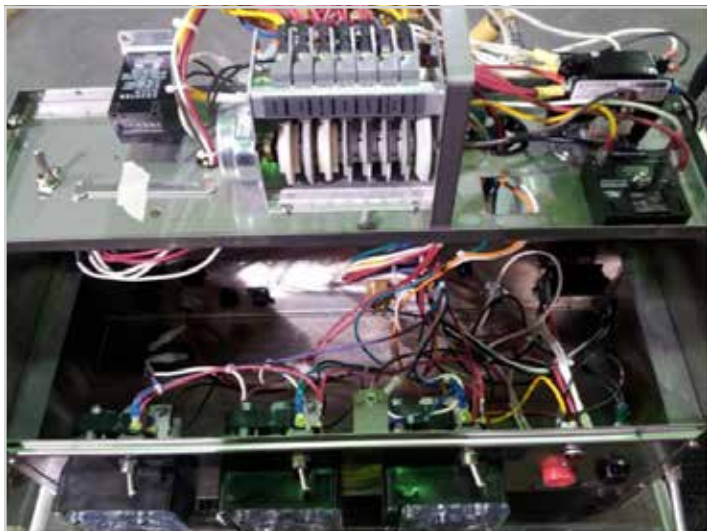

Showing control tray lifted to service pumps

The power supply for 120 volts, 20 amps shall consist of two #10-12-gauge wires and one suitable green ground wire. The 20 amp breaker or 20 amp fuse must be on a clean circuit for only the machine. ADS has provided a junction box with a 7/8" hole for the 1/2" conduit that will bring the building's electrical power to the machine. This junction box is attached to the back of the control box.

Remove the junction box cover, attach the conduit and connect a black 120 volt supply wire to the black wire in the junction box. Connect a white neutral supply wire to the white wire in the junction box. When powered up, test the neutral wire to a ground source with a volt meter, it should read 0 to 6 volts. Test the black wire to a ground source, it should read 110-120 volts. Attach a building ground wire to the green ground screw located in the junction box and tighten all wires. Replace the junction box cover and control box lid.



Showing L3DWS control box, chemical pumps, prime switches



Showing power connection box for 120v wiring

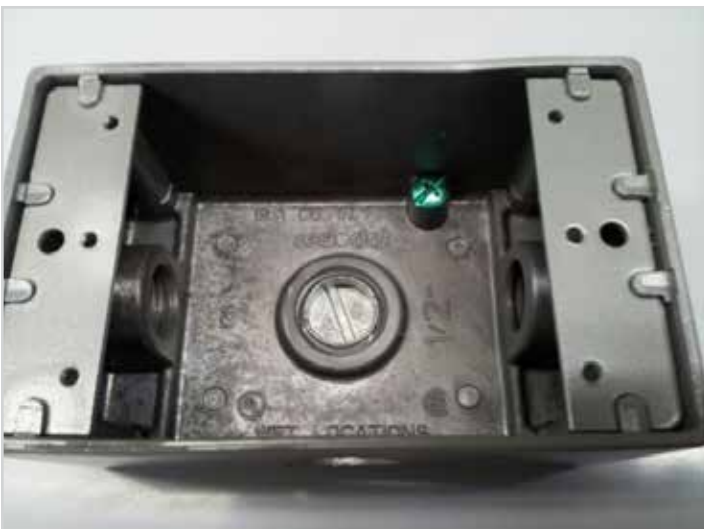

Ground screw in junction box



Line connection spades for L1, Neu (arrow 1 & 2)

IT IS RECOMMENDED THAT THIS EQUIPMENT BE INSTALLED USING A NEW CIRCUIT BREAKER.

This machine does not use a booster heater.

PLUMBING SECTION

NOTICE

#1 TANKLESS WATER HEATERS can be problematic for commercial dishmachines. The ADS model L90-3DWS dishmachine requires the full cycle amount of water (1.2 gallons) supplied within 10 seconds. It has been the experience of ADS that tankless supply systems require multiple units plumbed in sequence with a recirculation loop to achieve proper pressure and temperature.

Check with the tankless water heater manufacturer, they may recommend a storage tank to guarantee proper flow and line pressure to the machine. Failure to provide adequate water quantity, pressure and temperature to the machine will cause the machine to function improperly and is not the responsibility of ADS. Improperly installing ADS equipment in this manner could void the warranty. All costs associated with providing an adequate water supply to the machine is the sole responsibility of the user.

#2 HOODS—Follow all local plumbing and mechanical codes. IMC 2012, section 507.2.2 requires Type II hoods for all commercial dishwashers except where the heat and moisture loads are incorporated into the building's HVAC systems or dishwashing equipment designed with separate heat and moisture removal systems. A door-type, chemical sanitizing dishwasher is rated at 4770 Btu/h by table 5E, ASHRAE Research Project #1362, 8/5/2008. **ADS DOES NOT SPECIFY BUILDING HVAC VALUES.**

#3 DRAIN SIZE—Gravity drain line is 2" pipe size. Do not use reducing adapters for drain lines, always use same diameter pipe or larger. Close pump petcocks if equipped.





Showing 1/2" female pipe inlet, ball valve, y-line filter, water solenoid



ASSE approved air gap (backflow preventer)

Hot Water Connection

WATER HEATER—WATER HEATER—Flush the building's water lines before connecting to the dishmachine. Prior to connecting plumbing, level the machine by adjusting the feet at the bottom of each leg up or down. Water heaters or boilers must provide the minimum temperature of 120°F for this model of machine and have a minimum hourly demand of **44 GPH for L-90-3DW-S**. Temperatures above 150°F exceed the operational design limits for these models. These models cannot  be converted to high temp sanitizing by adding a booster.

INLET FLEX HOSE—Domestic style 1/2" flexible braided hose should not  be used to connect the dishmachine to plumbing. The ID of the plastic liner for this type hose restricts flow. Connect 1/2" male pipe thread (1/2" is the minimum allowable pipe size) of the hot water supply line to the 1/2" female pipe thread on the dishmachine's water inlet manifold.

SINK FAUCET—If the hot water line is also supplying the faucet of a pre-rinse sink, install check valves on both cold and hot water inlets to the faucet—to avoid cooling the water by cross-connection in the mixing head of the faucet. The hot water inlet manifold is located behind the L3DW-S control box. The supply water must have a minimum of 120°F, but 130-140°F is recommended for best results.

Water Pressure for Filling

Minimum pressure needed at the machine is 15 psi DURING the fill. This is called FLOW pressure. STATIC pressure readings can be misleading and can drop to "0" during fill. With flow pressures below 15 psi, additional measures will be needed to resolve the problem. The first suggestion is to run 3/4" pipe directly from the water heater to the dishmachine. If the problem persists, install a pressure bladder tank used for domestic well water; a 5 gallon size would be a minimum, 10 gallon as a maximum. Another option is to order a cam timer with longer cycle times but this will reduce hourly production rates.

Simple Test For Water Pressure

Empty the water out of the machine by lifting the drain ball, push the manual FILL button while counting the seconds to fill back up to the water level decal. If it takes more than 20 seconds to fill, there is not enough building water pressure to operate the machine properly.

Drain Requirements

To the rear of the scrap box there will be either a side exit or bottom exit fitting (depending on how it was ordered) that fits a rubber "no-hub" connector shipped inside the machine. This connector will fit 2" copper pipe or PVC tube. To prevent clogging, run drain lines as straight as possible. Do not run drain plumbing with tight radius elbows or 180-degree bends. The use of floor sinks for drains can cause flooding. Always run gravity drain lines downhill. Do not reduce the diameter of the drain pipe, always 2" or larger.



Showing L-3DW-S internal sump and scrap box



L-3DW-S scrap box in-frame mounting



Drain ball assembly, note rubber washer on push rod

SERVICE BULLETIN

Cautions on Inside Sump Drain Systems (ET-AF, AWF & AFWC)

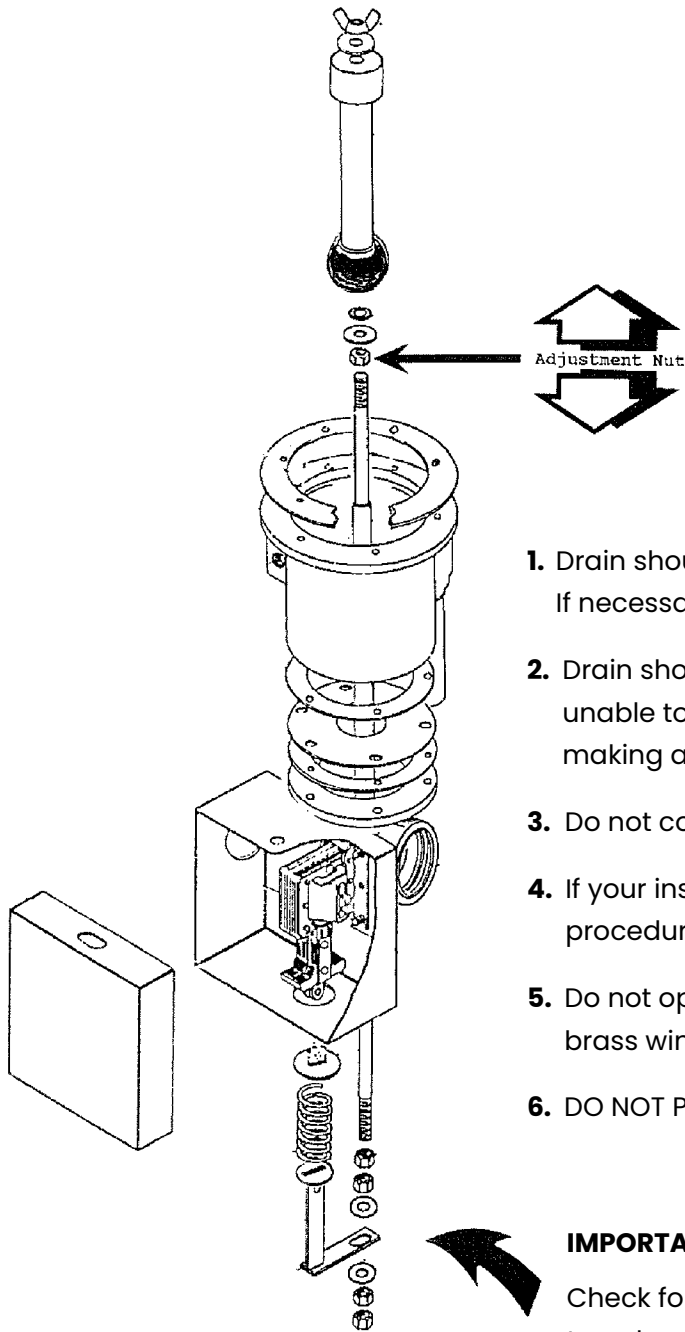

A. Unscrew wingnut and remove drain tube assembly from drain rod.

B. Using a 7/16" wrench, turn 1/4-20 nut clockwise two complete turns and re-assemble. This procedure regulates water flow to the drain, thus eliminating back pressure. If two complete turns does not eliminate the back pressure leak, repeat procedure to obtain desired results. **CAUTION:** Make sure when making adjustments that machine completely removes all water from tank in the drain cycle mode.

1. Drain should be plumbed with 1-1/2" pipe or larger. Do not reduce pipe. If necessary to reduce pipe, do it as far away from machine as possible.
2. Drain should be plumbed straight out 8" before making any turns. If unable to plumb straight out, then try to adapt to a larger pipe before making any turns.
3. Do not connect to a slow running or a plugged drain.
4. If your installation dictates that you cannot follow the recommended procedures (1-3), then the above drain adjustment may be necessary.
5. Do not operate machine with the water level too high. (Not above the brass wing nut on the drain tube.)
6. DO NOT PLUMB DRAIN UPHILL.

IMPORTANT:

Check for bent or binding rod and link. Adjust for smooth travel up & down.

CHEMICAL FEEDERS SECTION



WARNING

You must wear approved safety eye-wear before connecting chemicals. Read the chemical manufacturer's SDS sheets. Chemicals can damage or corrode plumbing and stainless parts of the dishwasher. Do not run chemical lines over controls or plumbing. Always secure chemical lines and check regularly for leaks. If not properly handled, chemicals can cause serious bodily injury. In the event of chemical contact to skin or eyes; wash immediately with fresh water and seek medical attention.

DE-LIME SWITCH—The de-lime switch is placed inside of the control box to avoid unauthorized operations. Because of potential hazards resulting from the combination of chlorine with acid solution, only authorized trained individuals should be allowed to de-lime a commercial dishwasher.

INSTRUCTIONS FOR USING THE DE-LIME FEATURE: First empty all water out of the machine by removing the drain ball from the seated position. After all water has emptied out, replace the drain ball and fill the machine with fresh water. Turn on the de-lime switch to operate the pump motor. Repeat this first step again by removing the drain ball, then refill and turn on the de-lime switch. This will flush the machine, refill again and this time add the de-lime acid. READ THE DIRECTIONS ON THE CONTAINER FOR CORRECT CONCENTRATION OF THE CHEMICAL. TYPICAL CONCENTRATION LEVELS 1:20 to 1:60.

Turn the de-lime switch on again and let it run long enough to return the inside of the machine to the appearance of shiny metal surfaces. It is best to de-lime more often with milder acid solutions than waiting until there is heavy build up of white minerals, then trying to remove the build up with very strong acid concentrations. Using too strong of an acid solution or running it for very long periods of time will erode the metal of the impeller because it is spinning in the acid solution.



De-lime switch in control box



Warning decal about mixing chemicals



Impeller damaged from high acid solution

CHEMICAL FEEDER PUMPS

ADS provides three (3) peristaltic pumps to dispense liquid chemicals

Chemical feed lines are color coded "Red" Detergent, "Green" Sanitizer, "Blue" Rinse-aid

Pick-up tubes are provided for chemical product containers

Sanitizer (chlorine) concentrations should be set at 50 parts per million

Inspect the transfer tubing for any cuts or holes, keep them protected and secured out of the way



Showing deter, rinse, sanitizer external pumps



Typical name plate information



Showing sump, drain ball, pump filter



Optional Chemical Alarm switch, buzzer

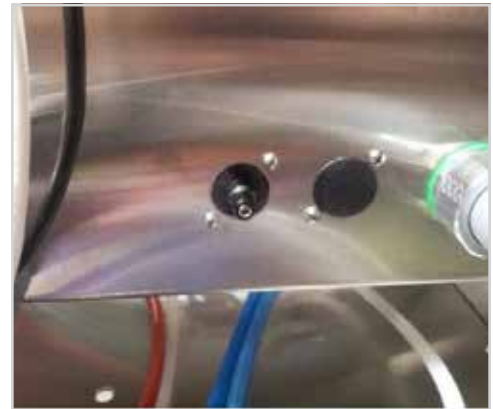

Chemical alarm barb adjusting screw*

TYPE OF CHEMICALS—Use only commercial grade low-energy chemicals. For proper operation, use non-foaming detergents and buffered sanitizer. Do not wash gold, pewter, silver, or silver-plate with chlorine based sanitizers. High concentrations of chlorine sanitizers and caustic detergents will cause damage to metals and welds. Do not exceed 50 parts-per-million (PPM) “free” or available chlorine. Any setting higher than 50 ppm will be dependent on local health requirements, however, the increased chlorine will result in higher corrosion of metal parts. Purpose-built ware-washing dispensers are needed to properly meter chemicals for wash and rinse. These dispensers are included with this model. Manually adding industrial chemicals to the dishwasher is unsafe and not approved.

CHEMICAL LINES—Place color coded tubes into proper chemical containers. The containers need to be as close to the machine as possible and at floor level. This may require shortening of the flexible chemical transfer tube. On the control box, there are chemical prime switches. There is a decal identifying each switch. To prime chemicals use these momentary prime switches, verifying that all three pumps rotate. If a chemical pump squeeze tube has taken a set (not allowing the pump to turn), manually free the pump by pulling on the discharge side (right-hand) of the squeeze tube while pushing the prime switch. Squeeze tubes should be replaced at least every six months.



WARNING

CONTAINERS: The ADS chemical delivery system is designed for 5 gallon pails of industrial low-energy chemical products. Always use chemical resistant safety gloves and safety goggles (indirect-vented or non-vented) when changing chemical buckets. Immediately report spills and refer to your chemical suppliers SDS safety data sheet or SDS material safety data sheet for information if chemical come in contact with skin or eyes.

Any modifications to the chemical delivery system for smaller containers must include **Closed Loop Chemical Containers** (spill proof bottles) in a secured racking system. It is the responsibility of the user of the machine to purchase chemicals in spill proof containers. **FAILURE CAN RESULT IN SERIOUS INJURY.** Never place chemicals in open containers or containers that can be easily tipped over when moving or changing product. Failure to do so will void your ADS warranty.

CHEMICAL ADJUSTMENT—Chemical dispensing is controlled by a mechanical cam timer. All chemical products must be adjusted for the product's concentration and local water conditions. It will be necessary to adjust initial factory settings (See below for Cam Timer Adjustment Section). Water softeners should be added to correct hard water conditions. Hard water is often treated with the more expensive ware washing chemicals, but it is more effective and less destructive to the metal to soften the water before it comes to the dishmachine.

AUDIBLE CHEMICAL ALARM OPTION—The optional chemical alarm (P/N [031-0326](#)) uses a pressure switch with a barb fitting that extends from the control box and connects to the chemical line by means of a "T" fitting. The switch sends voltage to a buzzer located in the control box. Sensitivity is adjusted by an Allen wrench (5/64" or 2mm) to turn a screw located in the center of the barb (see photo* p.9). Remove the tube from the barb; turn the screw to the right for less sensitivity. Chemical buckets must be placed on the floor for the pressure switch to work properly.

SOLID CHEMICAL PRODUCTS OPTION—ADS offers certain models with solid chemical dispensing for detergents and rinse additives. These dispensers are mounted on the hood next to the control box. Each dispenser is controlled by a water solenoid that is mounted in place of the liquid peristaltic pump. The initial signal comes from the cam timer. An optional metering relay is available for high concentration rinse additives. Cold Water Products require a separate water line connected to the 1/4" female compression fitting (provided). Hot Water Products require no additional plumbing. This option cannot be added in the field.

CAM TIMER ADJUSTMENT SECTION

Timers are available with 7- or 8-cams. The cycle times are not adjustable. The cams of the timer are wheels whose positions are either fixed or adjustable. Each cam controls a specific machine function, as noted on the timer decal. Adjustable cams are comprised of two wheels held together at the hub. The perimeter of each wheel is divided into 180-degrees of high cam and 180-degrees of low cam. When one of these wheels is rotated on the hub in relation to the opposing wheel, the two lower cam segments can form a notch in the perimeter. Above each cam is a timer switch with a metal finger that rides along the outer edge of the cam. When the finger drops into the lower cam notch, the function of that cam begins. To widen the notch (length = time energized) or close the notch use the timer adjustment tool, which is provided and taped to the control box shelf. This tool has two (2) raised buttons that fit into the holes on the side of each wheel. The factory sets the start of each function using the right-side wheel of the cam. TO ADJUST rotate only the left-side cam wheel. The left-side of the wheel controls the point when that specific functions ends. Factory settings are only initial settings, adjustments will be required for each chemical and the water fill time because water pressures will be different for every account.

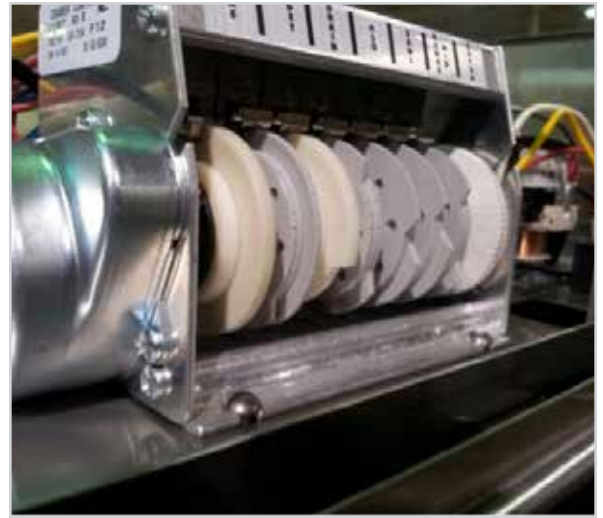

The arrow is pointed at the left-side wheel of the cam which is used to lengthen or shorten the low cam or the time ON for the respective switch. Adjustable cams are colored either black or gray.



Cam timer adjustment tool



Chlorine test strips



Spray arm pressure tester #088-1048

Looking at the front of the cams with the cam timer assembly sitting on its mounting base~read left to right

#1 Cam: The white cam on the left is the master cam. It controls the total time of the cycle and is not adjustable.

#2 Cam: Continuing left to right, this black or gray cam controls detergent. The detergent cam is adjustable and should begin as soon as the wash action starts.

#3 Cam: This white cam controls the drain time and is not adjustable.

#4 Cam: The H₂O or fill cam opens the water solenoid. Too little water will cause the pump to cavitate (surging). Overfilling does not allow the soiled wash water to fully drain between cycles, causing carry-over. Do not move the right side of the cam wheel. Adjust the left-side of the cam wheel to close the water solenoid when the dishwasher reaches full spray arm pressure.

#5 Cam: This black or gray cam controls sanitizer. The sanitizer cam is adjustable. Set sanitizer concentrations at 50 parts per million (Notice: Do not exceed 100 PPM's). Monitor chlorine levels by using chlorine test strips. To Test—run a rack of dishes through a complete cycle, use the test strip to test water samples from the top of any glass.

#6 Cam: This black or gray cam controls rinse additive. The rinse-aid cam is adjustable.

#7 Cam: This cam is used to pause or “burp” the pump on the 3D-S, ES, 5AG-S, 5CD, and L Series. It is set at the factory but can be adjusted.

TUNING A DUMP & FILL MACHINE SECTION

Tuning is essential for proper cleaning; do not skip this IMPORTANT PROCEDURE

The key to understanding proper tuning is to realize that the drain sequence cannot be changed. It is a fixed time function and the regulator of the cycle between wash and rinse. Therefore, all tuning is accomplished by setting or adjusting the fill cam in relationship to the fixed drain cam. The goal of tuning is to eliminate all soiled wash water through the drain, before the drain closes. A sign that soiled wash water has exited the tank will be the typical hollow sound of a pump running without water.

It is at this point that the H₂O (FILL) cam should be adjusted so the water solenoid turns the fill water on. That function is controlled by the adjustment of the fill cam. For optimum results, allow the fill water to flush the interior of the machine for a few seconds before the drain closes. Once the drain is closed the fill cycle begins. Fill must continue until full spray arm pressure is reached. This can be verified with the use of a spray arm pressure tester (Kit #088-1048) attached where one of the end plugs are usually screwed into the lower wash arm. The tester gauge will indicate full spray arm pressure when the needle stops fluctuating and remains steady. Adjust the fill cam to turn the water OFF when this point of steady pressure is reached. It is important that the machine is not overfilled. Use just enough water to reach Full Spray-arm Pressure (FSP), no more than that is needed for proper operation.

Typical 90-second timer operation

[Pump shut off] - [*sanitizer here]

START [----- WASH 50-Sec -----] - [- DRAIN 10-Sec -] - [--- 30-Seconds to FILL and Rinse ---] END

[*detergent here]

[-Fill until FSP is reached-]

If a pressure gauge tester is not available, an approximation of full spray arm pressure could be determined by the sound of the spray arms. There would be a typical continuous swishing sound of the water spraying. Again, when this sound is heard, that would be the point to turn the water OFF. Seven seconds of full spray arm rinse pressure is required by health code. In the event that air is trapped in the pump during fill, a vapor lock can occur where the pump is turning but there is no spraying.

If this vapor lock occurs, check incoming water temperature and reduce the temperature if it is above 140-150°F. Operating temperature of 120°F is the minimum, 130-140°F is recommended. If the problem is caused by low water pressure to the machine, then see the Plumbing Section above to correct that condition. If vapor lock is still present, electrically stop or pause the pump to release air. This machine has a 7th cam timer, the pause feature is wired into the 7th cam from the factory.

DOOR AND ARM SECTION

For the L-3DW-S in-line model, a conversion kit (088-1061) is available to change to a corner configuration. For the L-3DWC-S corner model, a conversion kit (088-1062) is available to change to an in-line configuration. The "L-3DW-S-3-doors-up" model is not convertible.



Showing ❌ misaligned arm, same is true for inline



Showing correct arm alignment

Care should be used in transporting and placing the machine, watch that the door arm is not twisted or bent. When dish tables are attached, watch that they do not bind and bend the door guides by lifting against the machine. This will cause binding of the guide on the door. When one door is standing above the top of the hood while the other door is resting down on the hood, this is caused by a door arm that is bent—hold one door arm handle down while lifting the handle of the other to align the arm handles. Use enough lifting force to bend the arm back into the correct position.

FINAL INSTALLATION CHECK LIST

- 1 Check to be sure power is disconnected at the breaker and the control box is switched OFF.
- 2 The master switch is located on the back of the control box for all Top Mount machines, under the control box on Front Mount machines. Open door and remove all packaging, save all instructions for future reference.
- 3 Remove the white protective film from doors, front panel, and control box.
- 4 Check dishtable placement, correct any binding or pinching caused to the dishmachine door guides by dishtables during installation.
- 5 Turn on water supply. Check for leaks. Tighten connections if needed.



Spray arm bearing with sealing o-ring



Spray arm end caps



L-3DWS spray arm (six jets)

- 6 TO OPERATE, turn on the main power circuit breaker and switch the dishmachine master switch to ON position. Remove spray arms and manually fill the machine with water using the fill switch (labeled FILL). This switch is located on the front of the control box. Run one complete cycle by closing the doors (optional auto/start machine only) or pushing the start switch (labeled START). This is the flush cycle, which removes installation debris from wash tank and pump.
- 7 AFTER FLUSHING, install the spray arms. These arms are interchangeable upper and lower. Failure to follow this flush procedure can damage spray arm bearings. Observe the water level decal. This decal is located on the outside of the sump area next to the drain tube of the machine. This mark is the approximate level for initial fill. Verify incoming water temperatures 120°F minimum, 130°F for the AFB (130–140°F recommended).
- 8 Inspect the sump area and verify pump filter is in place. Verify that chemical feed lines are in their proper container and that lines are primed. Post an operational wall chart close to the machine.



WARNING

Do not open doors while machine is in cycle. Doing so could result in serious bodily injury from spraying hot water and chemicals.

ADS Wire Chart (Ladder)

Model: L-90-3DW-S | L-90-3DWC-S

Connect to electrical supply source using 12-10 AWG copper wire

120 Volt Circuit Protection: 20 Amp Breaker or Fuse with a 2 AMP rating

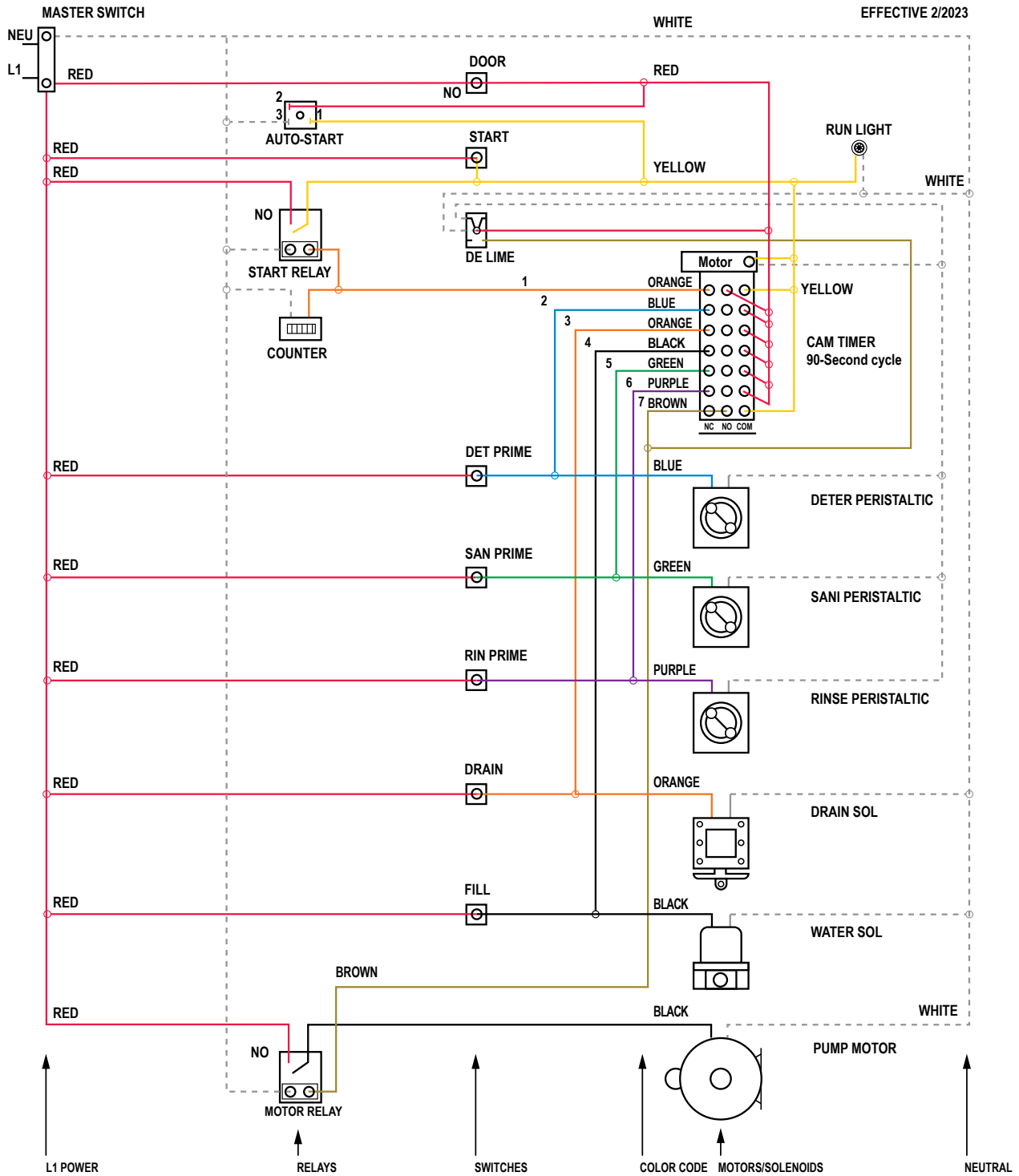

WARNING!

This product is manufactured solely for **commercial** use.
It is not to be used in residential installations of any kind.
Doing so will immediately void all warranties.
American Dish Service assumes no liability for such
unintended uses.

**FOR PARTS & SERVICE
MANUALS GO TO**

www.americandish.com



PRODUCTION FINAL INSPECTION

AMERICAN DISH SERVICE CORPORATION DISHMACHINE TEST



SERIAL #: _____

MODEL #: _____

DATE: _____

Checked:

- 1 Drain Ball - seated properly
- 2 No leaks around nuts & bolts
- 3 Chemical pumps traced, through prime switches, for proper operation *

Detergent	Rinse Aid	Sanitizer
<input type="checkbox"/> Prime	<input type="checkbox"/> Prime	<input type="checkbox"/> Prime
- 4 Pump - free from leaks.
- 5 Plumbing - free from leaks.
- 6 Tight nuts and bolts
- 7 Tight drain linkage.
- 8 Spray arms rotate freely.
- 9 Spray arm end plugs - secure.
- 10 Spray arm pressure - 16 PSI minimum.
- 11 Smooth door operation.
- 12 Smooth rack operation.
- 13 Nameplate properly installed and engraved.
- 14 Decals properly installed and are straight.
- 15 Overall machine operation is to standard.
- 16 Overall machine cleanliness is to standard.
- 17 General appearance of machine is free from scratches, dents, etc.

ELECTRICAL SAFETY

- 18 Hi Pot Test - passed to standard
- 19 Ground Test - passed to standard

I certify the above items have been checked and meet or exceed established American Dish Standards

Inspector: _____

***CUSTOMER NOTE: Cam adjustment varies with chemical concentrations. Adjust factory settings accordingly.**