

Mini Contact Toaster

Model VCT-2

Owner's Manual

Mfg. Numbers:

9210907 & 9210955

CONTENTS

General	2
Warranty	
Information	2
Service/Technical Assistance.....	2
Important Safety Information	3
Warnings	3
Specifications.....	4
Installation	5
Installing the Release Sheet	6
Bun Thickness Compression	
Knob Settings.....	6
Operating Instructions	7
Check Bun Thickness Compression	
Settings.....	7
Toasting Product	7
If product gets stuck inside toaster:.....	7
Adjusting Toast Quality	8
Shutting down the Toaster	8
Reset to Default Settings.....	8
Hi Limit Reset Button	8
Errors.....	8
Maintenance	9
Daily Maintenance.....	9
Weekly Maintenance.....	10
Monthly Cleaning.....	11
Quarterly Cleaning	13
Troubleshooting	15
Replacement Parts.....	16
Wiring Diagram.....	21
Notes.....	22
Limited Warranty	24

IMPORTANT

Antunes reserves the right to change specifications and product design without notice. Such revisions do not entitle the buyer to corresponding changes, improvements, additions or replacements for previously purchased equipment.

IMPORTANT

Keep these instructions for future reference. If the unit changes ownership, be sure this manual accompanies the equipment.

GENERAL

This manual provides the safety, installation, and operating procedures for your toaster. Please read all of the information contained in this manual prior to installing and operating the toaster.

Your toaster is manufactured from the finest materials available and is assembled to our strict quality standards. This toaster was tested at the factory to ensure dependable trouble-free operation.

WARRANTY INFORMATION

Please read the full text of the Limited Warranty in this manual.

If the unit arrives damaged, contact the carrier immediately and file a damage claim with them. Save all packing materials when filing a claim. Freight damage claims are the responsibility of the purchaser and are not covered under warranty.

The warranty does not extend to:

- Damages caused in shipment or damage as result of improper use.
- Installation of electrical service.
- Normal maintenance as outlined in this manual.
- Malfunction resulting from improper maintenance.
- Damage caused by abuse or careless handling.
- Damage from moisture into electrical components.

Damage from tampering with, removal of, or changing any preset control or safety device.

SERVICE/TECHNICAL ASSISTANCE

If you experience any problems with the installation or operation of your system, contact Antunes Technical Service +1-877-392-7854 (toll free).

Fill in the information in the next column and have it handy when calling for assistance. The serial number is on the specification plate located on the system.

Purchased From

Date of Purchase

Model Number

Serial Number

Mfg. Number

Use only genuine Antunes replacement parts in this unit. Use of replacement parts other than those supplied by the manufacturer will void the warranty.

IMPORTANT SAFETY INFORMATION

Use the following guidelines for safe operation of the unit.

- Read all instructions before using equipment.
- For your safety, the equipment is furnished with a properly grounded cord connector. Do not attempt to defeat the grounded connector.
- Install or locate the equipment only for its intended use as described in this manual. Do not use corrosive chemicals in this equipment.
- Do not operate this equipment if it has a damaged cord or plug, if it is not working properly, or if it has been damaged or dropped.
- This equipment should be serviced by qualified personnel only. Contact Antunes Technical Service for adjustment or repair.
- Do not block or cover any openings on the unit.
- Do not immerse cord or plug in water.
- Keep cord away from heated surfaces.
- Do not allow cord to hang over edge of table or counter.
- Turn the power off, unplug the power cord, and allow unit to cool down before performing any service or maintenance on the unit.
- The equipment should be grounded according to local electrical codes to prevent the possibility of electrical shock. It requires a grounded receptacle with separate electrical lines, protected by fuses or circuit breaker of the proper rating.
- All electrical connections must be in accordance with local electrical codes and any other applicable codes.
- Do not clean this appliance with a water jet.

WARNINGS

Be advised of the following warnings when operating and performing maintenance on this unit.

- If the supply cord is damaged, it must be replaced by the manufacturer or its service agent or a similarly qualified person in order to avoid a hazard.
 - Do not modify the power supply cord plug. If it does not fit the outlet, have a proper outlet installed by a qualified electrician.
 - Do not use an extension cord with this appliance.
 - Electrical ground is required on this appliance.
 - Check with a qualified electrician if you are unsure if the appliance is properly grounded.
 - If a chemical cleaner is used, be sure it is safe to use on cast aluminum. Observe all precautions and warnings on product label.
 - Inspection, testing, and repair of electrical equipment should only be performed by qualified service personnel.
 - This equipment is to be installed to comply with the basic plumbing code of the Building Officials and Code Administrators, Inc. (BOCA) and the Food Service Sanitation Manual of the Food and Drug Administration (FDA).
- Do not use abrasive materials. The use of these may cause damage to the stainless steel finish.
 - Chlorides or phosphates in cleaning agents (e.g. bleach, sanitizers, degreasers or detergents) could cause permanent damage to stainless steel equipment. The damage is usually in the form of discoloration, dulling of metal surface finish, pits, voids, holes, or cracks. This damage is permanent and not covered by warranty.
 - The following tips are recommended for maintenance of your stainless steel equipment:
 - Always use soft, damp cloth for cleaning, rinse with clear water and wipe dry. When required, always rub in direction of metal polish lines.
 - Routine cleaning should be done daily with soap, ammonia detergent, and water.
 - Stains and spots should be sponged using a vinegar solution.
 - Finger marks and smears should be rubbed off using soap and water.
 - Hard water spots should be removed using a vinegar solution.

SPECIFICATIONS

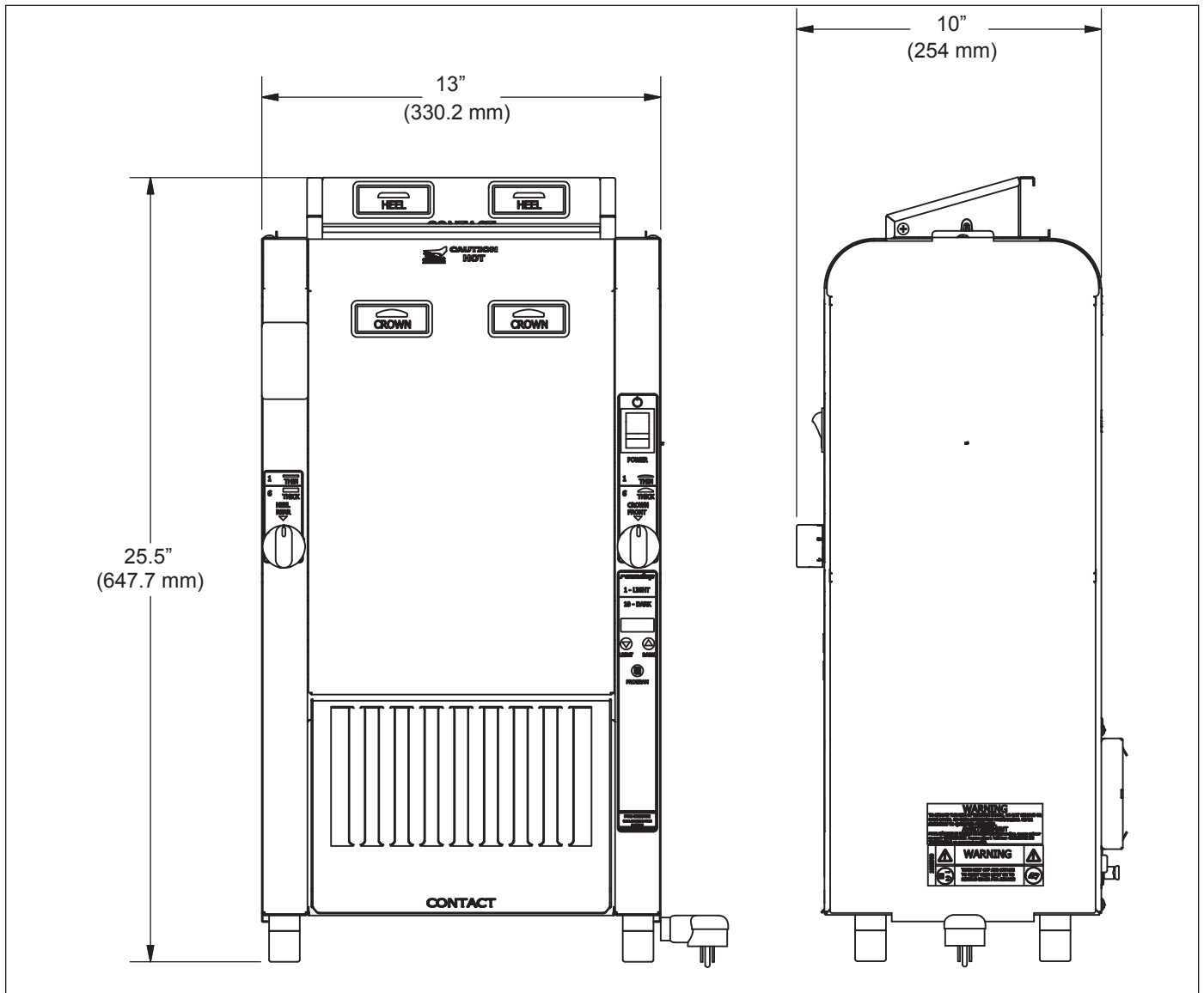

Model & Mfg. No.	Volts	Watts	Amps	Hertz	Plug Description
9210907 VCT-2 (Belt Wraps)	120	1800	15	50/60	5-15P 15 Amps., 120 V., Non-Locking (assembly only)
9210955 VCT-2 (No Belt Wraps)	120	1800	15	50/60	5-15P 15 Amps., 120 V., Non-Locking (assembly only)

INSTALLATION

NOTE: When placing the toaster into service, make sure to provide at least 3 inches of space on all sides of the unit.

1. Remove unit and all packing materials from shipping carton. The toaster is shipped with an accessories box that includes the items listed below:
 - Bun Feeder Assembly
 - Bun Chute
 - Release Sheet (pkg. Of 2) A Release sheet is also shipped installed onto the unit platen.
 - Platen Cleaning Tool
 - Owner's Manual

NOTE: If any parts are missing or damaged, contact Antunes Customer Service IMMEDIATELY at +1-877-392-7856 (toll free).

2. Remove all packing materials and protective coverings from the unit.

3. Refer to Figure 1. Wash, rinse, and sanitize the Bun Feeder, Bun Chute, and Cleaning tool at the 3 compartment sink and set aside to air dry.

NOTE: The removable parts have CONTACT etched on them to make it easier to identify which toaster they belong to.

4. Refer to Figure 2. Remove the Release Sheet.

NOTE: Do not wash the Release Sheet in the sink. The Release Sheet **must** be washed by hand.

5. Wipe all surfaces of the unit with a hot damp cloth.
6. Wipe both sides of the Release Sheet with a hot damp cloth.

NOTE: Do NOT use a dripping wet cloth. Wring out before use.

7. Install the Bun Feeder and Bun Chute onto the unit (Figure 1).

8. Refer to the section titled **Installing the Release Sheet** on the next page. Install the Release Sheet according to those instructions.
9. Store the Platen Cleaning Tool in an accessible place.

When placing the unit into service, pay attention to the following guidelines.

- Make sure to provide at least 3 inches of space on all sides of the unit.
- Make sure the power switch is off and the unit is at room temperature before plugging in the power cord.
- Do not block or cover any openings on the unit.
- Do not immerse the power cord or plug in water.
- Keep the power cord away from heated surfaces.
- Do not allow the power cord to hang over edge of table or counter.

Figure 1

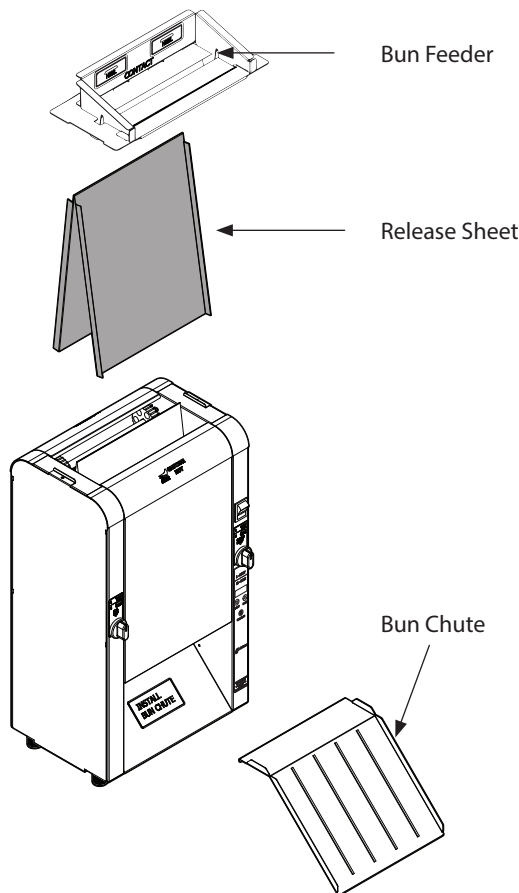
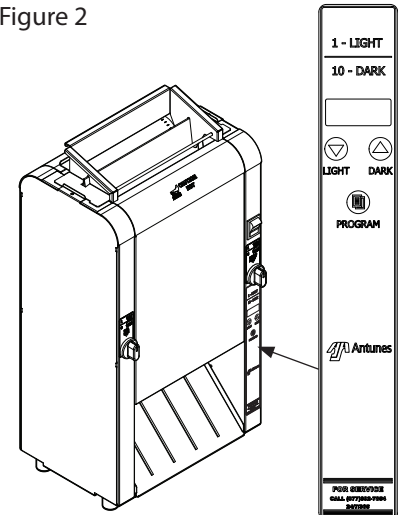

Figure 2



NOTE: The main Control Panel is located on the front of the unit.

INSTALLING THE RELEASE SHEET

The Release Sheet allows buns to pass through the toaster without sticking. The toaster should never be operated without a clean Release Sheet installed.

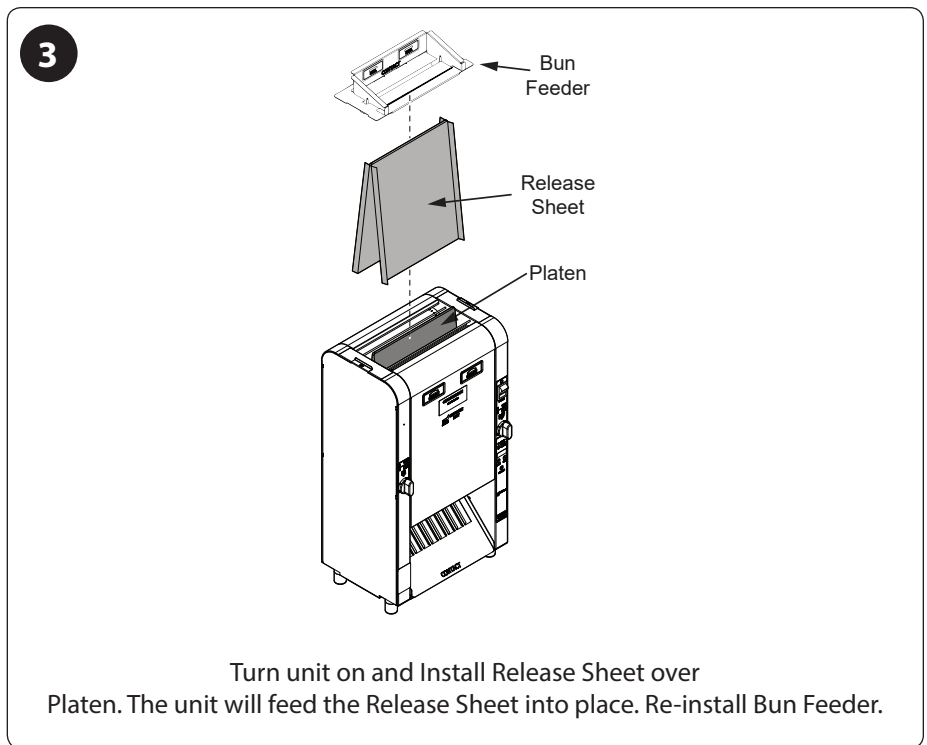
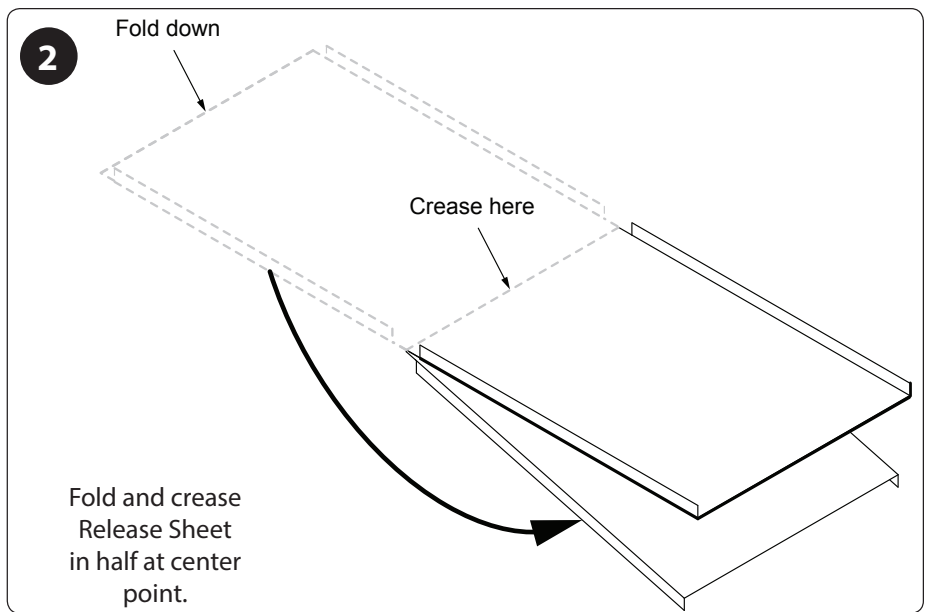
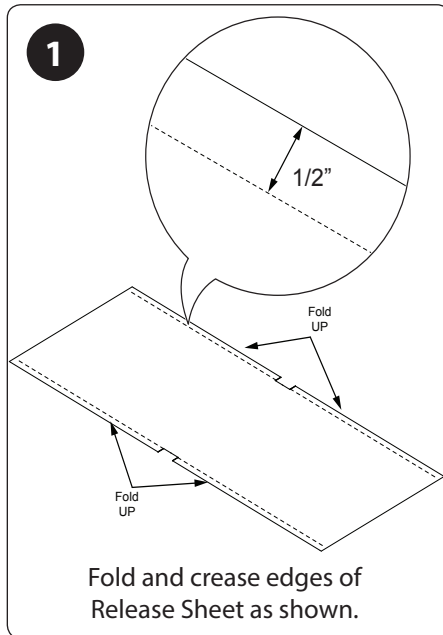

BUN THICKNESS COMPRESSION KNOB SETTINGS

The toaster uses two Bun Thickness Compression Knobs for proper toasting of buns (heels and crowns).

For best results, set both Bun Thickness Compression Knobs to 4.

The compression settings range from 1 to 6. Setting 1 is the thinnest setting and Setting 6 is the widest setting.

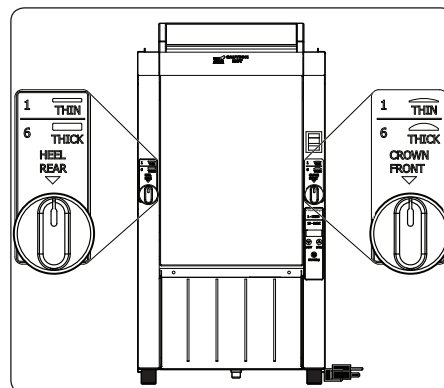

WARNING

Do NOT operate the toaster without the release sheet installed. Do not use any abrasive cleansers or tools such as scrubbers or scrapers on the Platen. Damage to the Platen from operation without a Release Sheet or damage caused from abrasive cleansers or tools voids the warranty.

OPERATING INSTRUCTIONS

NOTE: If the toasting quality needs adjustment, refer to the section titled “Adjusting Toasting Quality” in the Operation section of this manual.

1

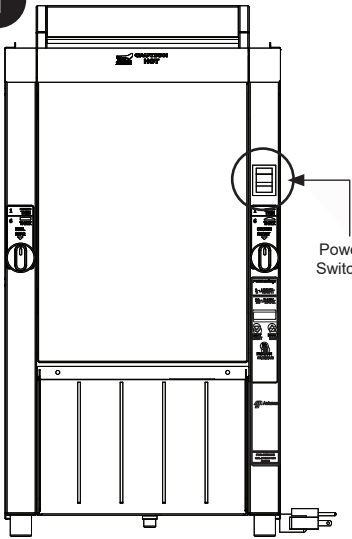

Power Switch.

Verify that the toaster is clean and assembled correctly. Turn the Power switch to the on position. The unit makes a clicking sound. This is normal.

2



The unit displays the software version, the current platen setpoint temperature and starts to warm up.

3



After the system check, the unit begins to warm up and Lo-P appears on the display.

4



The unit displays the USE message when it reaches proper operating temperature (in approximately 10 minutes).

CHECK BUN THICKNESS COMPRESSION SETTINGS

Before toasting product, verify that the Bun Thickness Compression Knobs are set appropriately. The typical settings for crowns and heels is #4, however these can be changed according to product thickness. See the section titled “Bun Thickness Compression Knob Settings” for more information.

TOASTING PRODUCT

Test the toaster before use by toasting 1 bun and 1 slice of Wheatberry bread. Facing the front of the unit, insert product as described:

- Bun - Feed crown into front slot and heel into back slot, with cut sides facing each other.
- Wheatberry bread - place 1 slice of bread into back slot.

Check the color against Quality Photos (Buttered White Bun Toasting, Multi grain Bun Toasting, Chicken Salad Sandwich toasting). Adjust settings if needed.

TOASTING PRODUCT

Test the toaster before use by toasting

- Insert Crowns into the front lane with the cut side facing in.
- Insert Heels into the rear lane with the cut side facing in.

Refer to the image below.

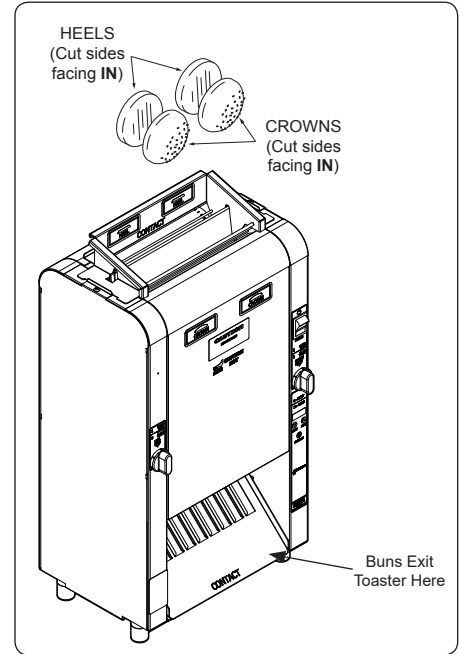

IF PRODUCT GETS STUCK INSIDE TOASTER:

If buns or a bread slice gets stuck inside the toaster, use the platen tool to dislodge it from the toaster. Before using the platen tool:

1. Insert one edge of a new scrub pad onto the top slot of the platen tool.
2. Insert the other edge of the scrub pad into the bottom slot. Make sure the scrub pad is flat against the tool.
3. From the top of the toaster, insert the platen tool with the pad facing the middle of the toaster. Dislodge product.

WARNING
Do NOT use the platen tool without a scrub pad installed. Be sure to insert the platen tool into the toaster with the scrub pad facing the toaster platen. Do not allow the metal portion of the platen tool to contact the toaster platen.

ADJUSTING TOAST QUALITY

The unit can be adjusted to provide a lighter or more darkly toasted product.

The lightest setting is 1 and the darkest setting is 10.

Follow these steps to adjust toasting quality.

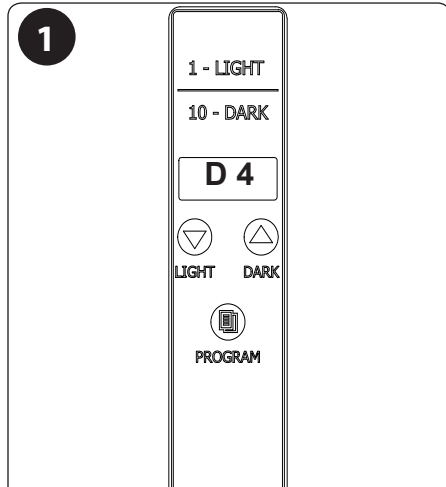

To view the current Light/Dark setting, briefly press **Light** or **Dark** button. The current Light/Dark setting appears in the display.

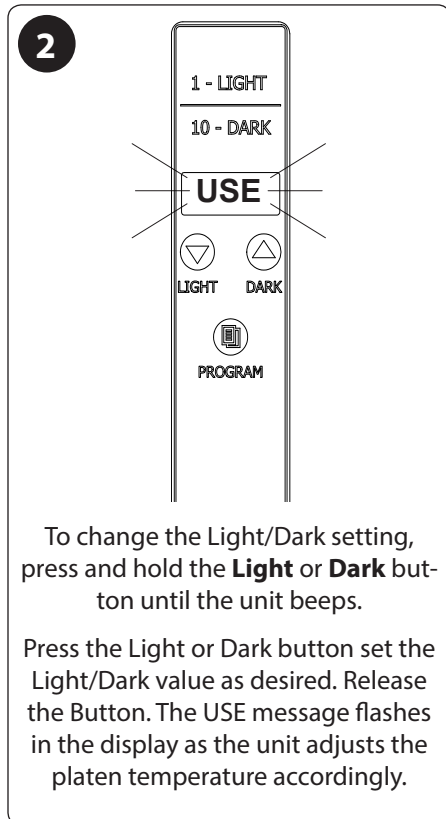

To change the Light/Dark setting, press and hold the **Light** or **Dark** button until the unit beeps.

Press the Light or Dark button set the Light/Dark value as desired. Release the Button. The USE message flashes in the display as the unit adjusts the platen temperature accordingly.

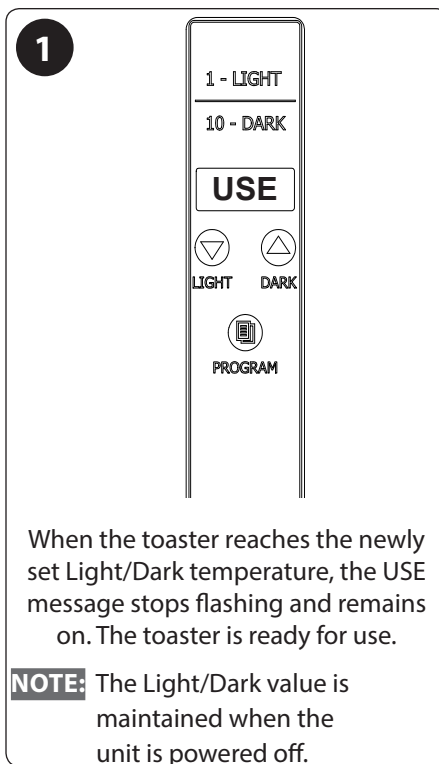

When the toaster reaches the newly set Light/Dark temperature, the USE message stops flashing and remains on. The toaster is ready for use.

NOTE: The Light/Dark value is maintained when the unit is powered off.

SHUTTING DOWN THE TOASTER

To turn the toaster off, turn the Power switch to the off position.

RESET TO DEFAULT SETTINGS

Follow these steps to reset the toaster to the factory settings

Follow these steps to reset to default settings:

1. Turn the toaster off.
2. Press and hold both the Light and Dark buttons and turn the toaster on.
3. Continue holding the Light and Dark buttons until "fr" (factory reset) appears in the display. The toaster beeps when resetting is done and starts up normally.

HI LIMIT RESET BUTTON

A hi-limit control turns off power to the unit if it overheats. To reset this Hi-Limit control, allow sufficient time (10-15 minutes) for the unit to cool down, then remove the Hi-Limit control cap and press the reset button located on the rear of the unit. If the unit requires continuous resetting, call for service.

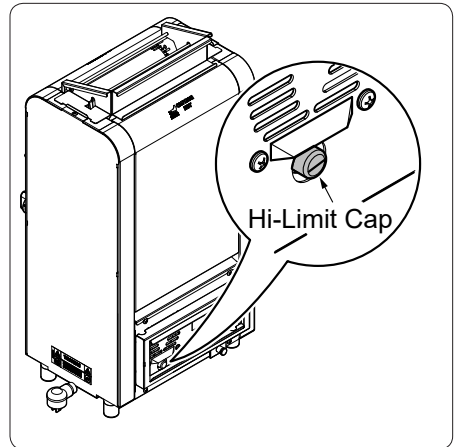

ERRORS

The toaster displays any kind of error message, contact the factory immediately at 1-630-784-1000

MAINTENANCE

WARNING

The unit will remain hot while it is cooling down. Personal injury and burns may result from touching the unit before it is finished cooling down. Wear Heat Resistant Gloves.

DAILY MAINTENANCE

NOTE: The following are general maintenance procedures. For additional details including approved chemicals, please see the Toaster Procedure documents by scanning the QR Code on the front page of this manual.

The daily maintenance steps involve:

- Cleaning the Accessories and Toaster
- Cleaning the Release Sheet

Cleaning the Accessories and Toaster

1. Turn the toaster off and allow it to cool before proceeding.
2. Refer to Figure 3. Remove the Bun Feeder, Release Sheet, and Bun Chute and set aside.

NOTE: Do not wash the Release Sheet in the sink. It **must** be washed by hand.

3. Wash the Bun Feeder and Bun Chute in soap and water. Rinse with clean water and allow to air dry.
4. Wipe all surfaces of the unit with a hot damp cloth.

NOTE: Do not use a dripping wet cloth. Wring out before use.

Cleaning the Release Sheet

1. Inspect the Release Sheet. Replace the Release Sheet if it is worn, creased, or torn.
2. Spray an approved cleanser on a clean, dry towel.
3. Wipe the Release Sheet firmly from top to bottom.
4. Repeat this procedure with a clean, dry towel dampened with water.

5. Next, wipe the release sheet with a clean towel dampened with an approved sanitizer. Allow to air dry.
6. Repeat Steps 1 through 6 on the inside portion of the Release Sheet. Set the clean Release Sheet aside.

Cleaning the Belt Wraps

7. Open the front and rear Conveyor Covers (Figure 4a)
8. Inspect the front and rear Belt Wraps. Replace the Belt Wraps if there are any signs of tearing, folding, or other damage.
9. Turn on the unit.

NOTE: This step requires that the toaster be turned on with the Conveyor Covers open. Use caution during these steps.

10. Spray a clean, sanitized towel with an approved cleanser and wipe the front and rear Belt Wraps for one full rotation.
11. Repeat Step 4 with an approved sanitizer.

NOTE: Repeat these steps as needed until the Belt Wraps are clean and tacky/sticky to the touch.

12. Reinstall the Release Sheet, Bun Chute, and Bun Feeder and return the toaster to operation.

Cleaning the Rear Fan

Use a clean dry cloth and wipe the fan intake. If there is heavy debris buildup, use an Ecolab Detail Brush (item# 92212765) followed by a clean, dry cloth (see Figure 4b).

Figure 3

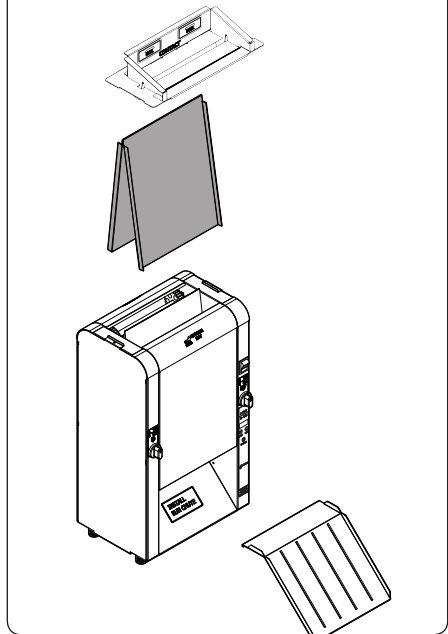

Figure 4a

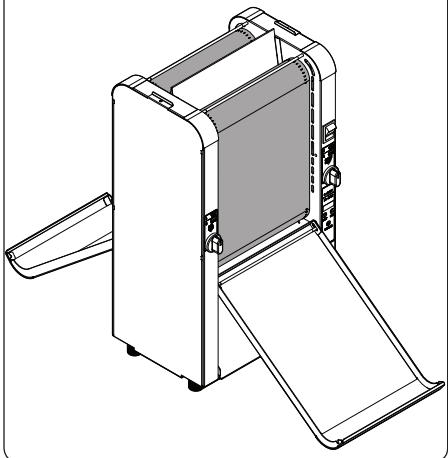
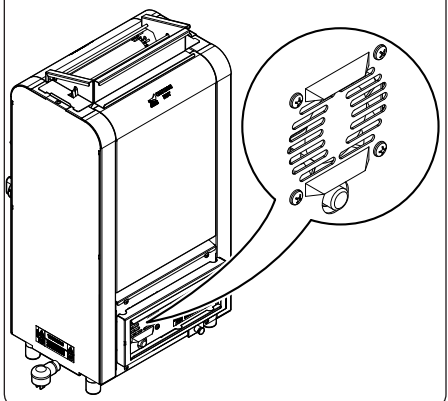

Figure 4b



WEEKLY MAINTENANCE

The following weekly maintenance is recommended only when buttering buns prior to toasting them:

Butter buildup on the platen will have a negative affect on toast quality. Follow the procedure below to clean the platen.

1. Turn the unit off, unplug the power cord and allow the unit to cool down for 15 minutes.
2. Put on heat resistant gloves. Remove the Bun Feeder, Release Sheet, and Bun Chute (Figure 6). Set these items aside.
3. Set both Bun thickness Compression Knobs to 6. (Figure 7).
4. Place a red food tray in front of toaster to collect drips from cleaning.
5. Insert a scrub pad into platen tool (Figure 5).
 - a. Inspect scrub pad to ensure it is clean and undamaged. Discard scrub pad if it has loose shreds, food particles or debris stuck in fibers.
 - b. Insert one edge of scrub pad into top slot.
 - c. Then, insert other edge into bottom slot, making sure pad is flat.
6. Prepare clean rinse water. It is helpful to have water in a 12 qt container next to toaster during cleaning process.
7. Spray Sizzle onto scrub pad.
8. Scrub each side of toasting platen gently with scrub pad, applying additional Sizzle to scrub pad as needed (Figure 5)

NOTE: Front and rear covers of toaster should be closed during this step to prevent Sizzle from dripping on the belt wraps or other areas of toaster.

9. Rinse scrub pad in clean water.
 - a. Press against scrub pad with gloved hand, while it is in water, to rinse it out.
 - b. Squeeze out excess water by scraping scrub pad against edge of container.

NOTE: It is important to squeeze out excess water because too much water dripping into toaster can damage electronic components.

10. Scrub each side of toasting platen gently with rinsed scrub pad to remove Sizzle residue. Continue rinsing scrub pad and scrubbing platen gently until all residue has been removed from platen.

NOTE: It will be necessary scrub each side of toasting platen with rinsed scrub pad approximately 4-5 times to remove all Sizzle residue.

11. Discard scrub pad. Scrub pads are for single use only.
12. Remove bun chute and red food tray and take them to compartment sink for cleaning.
13. Complete remaining steps in daily cleaning process. (See Contact Toaster: Cleaning Contact Toaster at End of Day.)

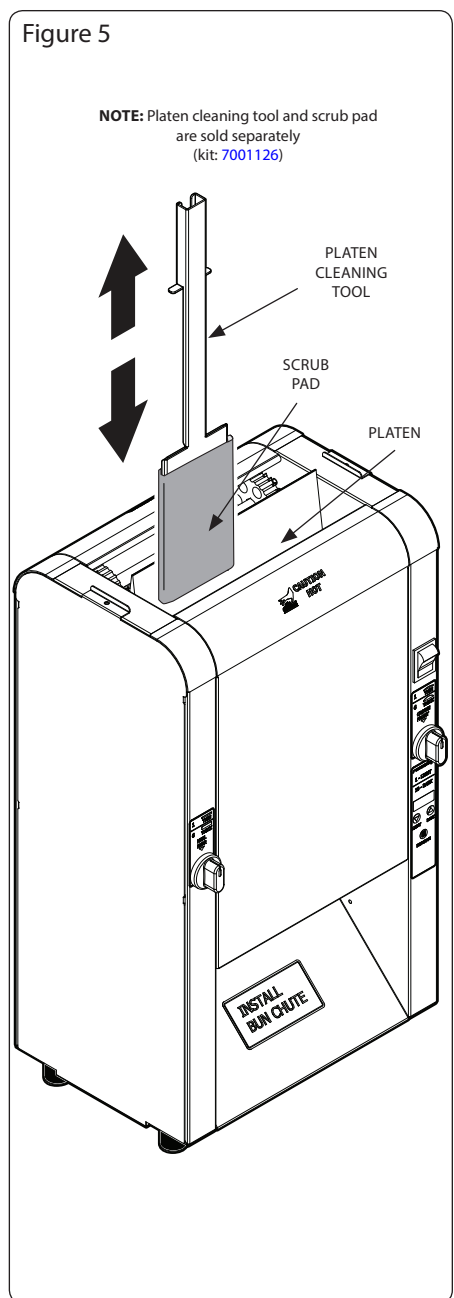

MONTHLY CLEANING

The monthly preventative maintenance steps include:

- Cleaning the Conveyor Belt Chains
- Checking the Conveyor Belt Chains for Stretching

Cleaning the Conveyor Belt Chains

1. Turn the unit off, unplug the power cord, and allow the unit to cool down.
2. Put on heat resistant gloves. Remove the Bun Feeder, Release Sheet, and Bun Chute (Figure 6). Set these items aside.
3. Set both Bun thickness Compression Knobs to 6. Next, open both Conveyor Covers (Figure 7).
4. Remove both Belt wraps if present- lift the flap on the Belt Wrap and pull the Pin out of the zipper (Figure 8). Disconnect the Belt Wrap clips from the Conveyor Chain and remove the Belt Wraps from the toaster (Figure 8).
5. Inspect the Belt Wraps (if present) for rips or tears. If the Belt Wraps are in good condition, set them aside. They will be reinstalled onto the toaster later in this process.
6. Use a clean, nylon brush to remove all debris and residue from the Conveyor Belt Chains. Do this on both sides of the toaster.
7. Clean and sanitize the front and rear Conveyor Belt Chain with a green scrub pad sprayed with Super contact Cleaner solution. Wipe the links of the Conveyor Belt Chain firmly from side to side until they are completely free of residue and debris (Figure 9). Then, Wipe the Chains with a clean sanitizer soaked towel.
8. Plug in the power cord and turn the unit on. Wait for both Conveyor Belt Chains to rotate and expose the uncleaned portion of the chains. Turn the unit off and unplug the power cord again. Repeat Steps 6 and 7 to clean and sanitize the soiled side of the Conveyor Chains.

NOTE: You may need to repeat steps 7 and 8 to ensure the Conveyor Belt Chains are completely free of debris and cleanser.

Figure 6

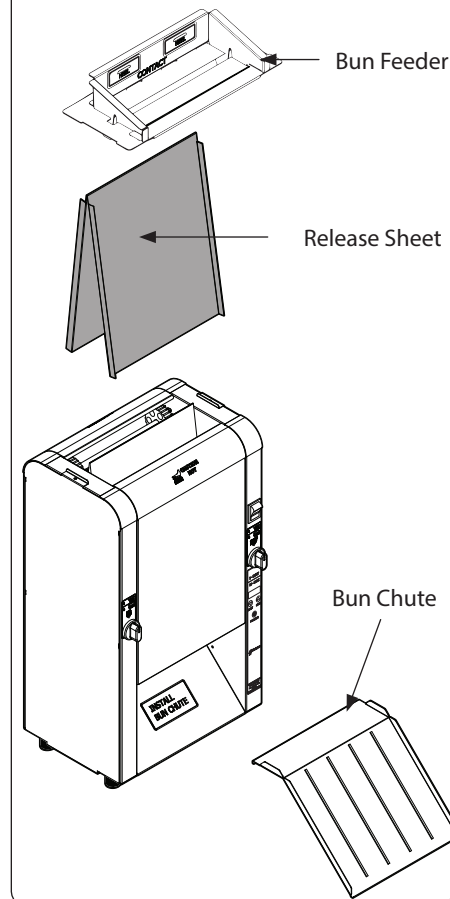

Figure 7

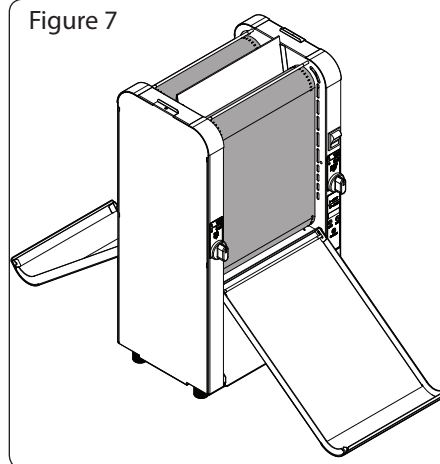

Figure 8

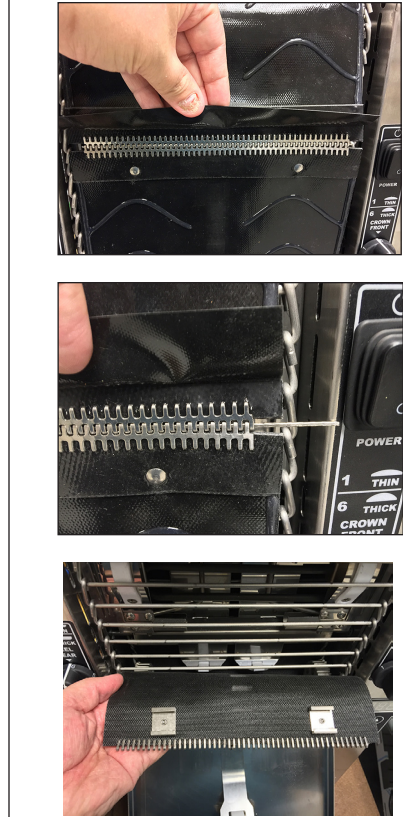
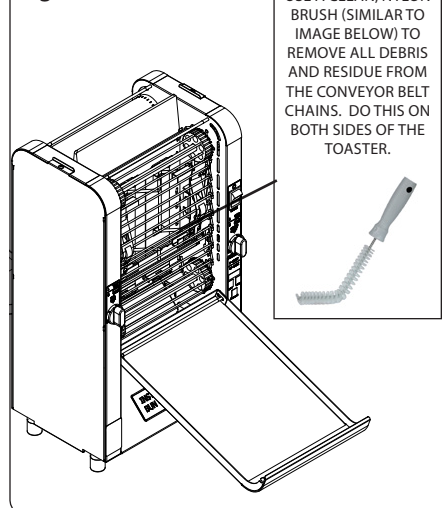

Figure 9



Checking the Conveyor Belt Chains for Stretching

1. Set the Bun Thickness Compression Knobs to 6 and 6 and ensure both Belt Wraps are removed.
2. Locate the approximate center-point of the Conveyor Belt Chain.
3. Pull the Conveyor Belt Chain away from the edge of the toaster (Figure 10).
4. Using a U.S. Dime coin (1.8 cm) for reference or a ruler, measure the space between the toaster frame and the Conveyor Belt Chain (Figure 10). The coin should fit snugly.
5. If the gap is more than twice the width of the coin (2.6 cm):
 - a. Disconnect the Conveyor Belt chain by squeezing any two links together and unhooking both ends of the one link (Figure 11). Pliers may be used.

NOTE: There are two small 1/2 inch links on each side of the Conveyor Belt Chain. The rest are large 3/4 inch links.

- b. Depending on how loose the chain is, remove a 1/2" or 2/4" link.

NOTE: It is recommended to perform the Quarterly Cleaning any time you disconnect or remove a Conveyor Belt Chain from the toaster.

- c. Reassemble the Conveyor Belt Chain onto the sprockets.

NOTE: Make sure the Conveyor Belt Chain hooks are pointing **DOWN** as shown in Figure 10.

- d. Measure the gap again to confirm the gap is approximately the width of the U.S. Dime coin.
6. If the Conveyor Belt Chain is too tight, remove a small 1/2 inch link and install a large 3/4 inch link in its place. This increases the length of the Conveyor Belt Chain by 1/4 inch overall.
 7. Repeat steps 1 through 6 on the opposite Conveyor Belt Chain.

Figure 10



Figure 11

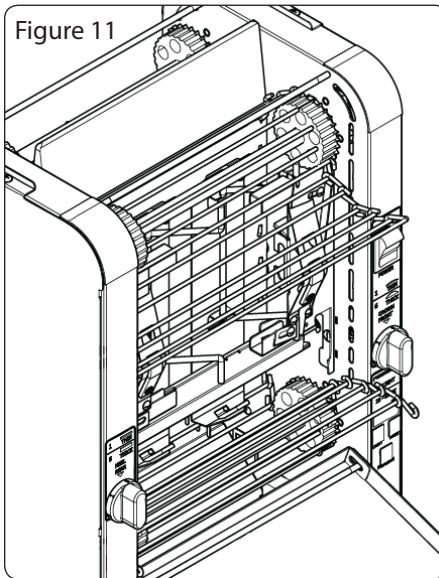

Reassembling the Toaster

1. Reinstall the Belt Wraps onto the toaster under the yellow rods and making sure the flap is pointing down.
2. Connect the Belt Wrap clips to the Conveyor Belt Chain.
3. Then, reconnect the ends of the Belt Wraps with the Belt Wrap Pin, making sure the zipper teeth are properly aligned (Figure 13)

NOTE: Make sure the Belt Wraps are installed under the yellow rods.

4. Close the Conveyor Covers.
5. Reinstall the Release Sheet, Bun Chute, and Bun Feeder and return the toaster to operation.

Figure 12

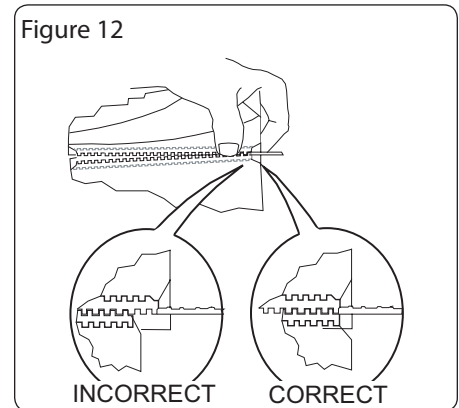

QUARTERLY CLEANING

The Quarterly Cleaning involves cleaning the interior of the unit.

1. Turn the unit off, unplug the power cord and allow the unit to cool down.
2. Put on heat resistant gloves. Remove the Bun Feeder, Release Sheet, and Bun Chute (Figure 6). Set these items aside.
3. Set both Bun thickness Compression Knobs to 6. Next, open both Conveyor Covers (Figure 7).
4. Remove both Belt wraps if present- lift the flap on the Belt Wrap and pull the Belt Wrap Pin out of the zipper (Figures 8). Disconnect the Belt Wrap clips from the Conveyor Belt Chain and remove the Belt Wraps from the toaster (Figure 8).
5. Inspect the Belt Wraps (if present) for rips or tears. If the Belt Wraps are in good condition, set them aside. They will be reinstalled onto the toaster later in this process.
6. Disconnect the Conveyor Belt chains by squeezing any two links together and unhooking both ends of the one link (Figure 14). Pliers may be used. Remove the Conveyor Belt Chains and set aside.
7. Use a clean, nylon brush to carefully remove all debris and residue from the inside components of the toaster (Figure 15). Do this on both sides of the toaster.

NOTE: With proper and regular daily and monthly cleaning, the interior of toaster should be free of residue and debris. If you find that the interior is extremely dirty on a regular basis, please review how the daily and monthly the frequency and daily and monthly cleaning steps.

8. Reassemble the Conveyor Belt Chain onto the sprockets.

NOTE: Make sure the Conveyor Belt Chain hooks are pointing **DOWN** as shown in Figure 10.

9. For Mfg. No. 9210907, re-install the Belt Wraps onto the toaster under the yellow rods and making sure the flap is pointing down.
10. Connect the Belt Wrap clips to the Conveyor Belt Chain.
11. Then, reconnect the ends of the Belt Wraps with the Belt Wrap Pin, making sure the zipper teeth are properly aligned (Figure 13).

NOTE: Make sure the Belt Wraps are installed under the yellow rods.

12. Close the Conveyor Covers.
13. Reinstall the Release Sheet, Bun Chute, and Bun Feeder and return the toaster to operation.

Figure 14

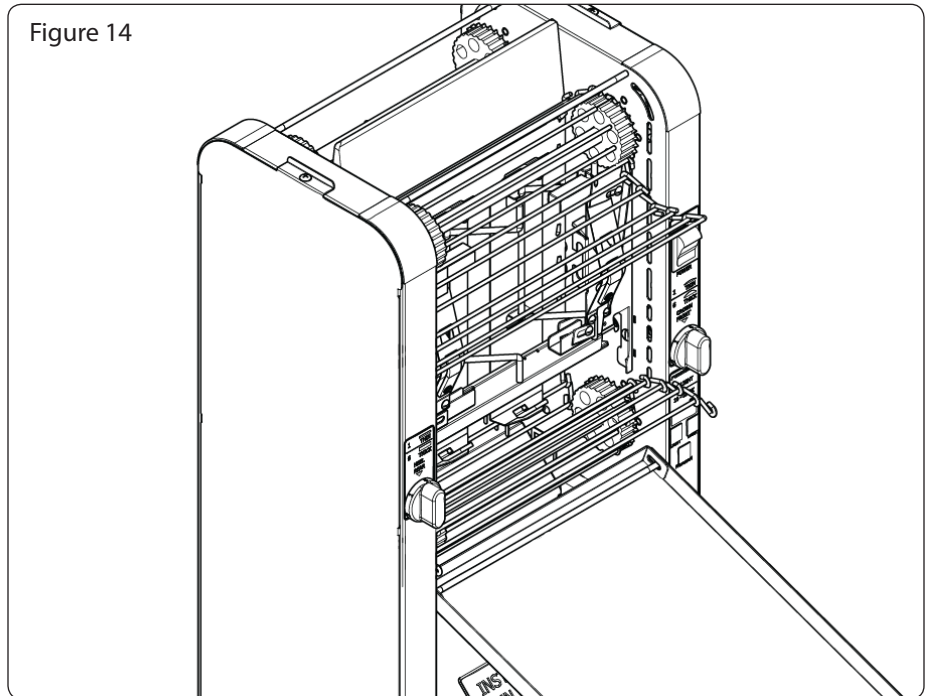
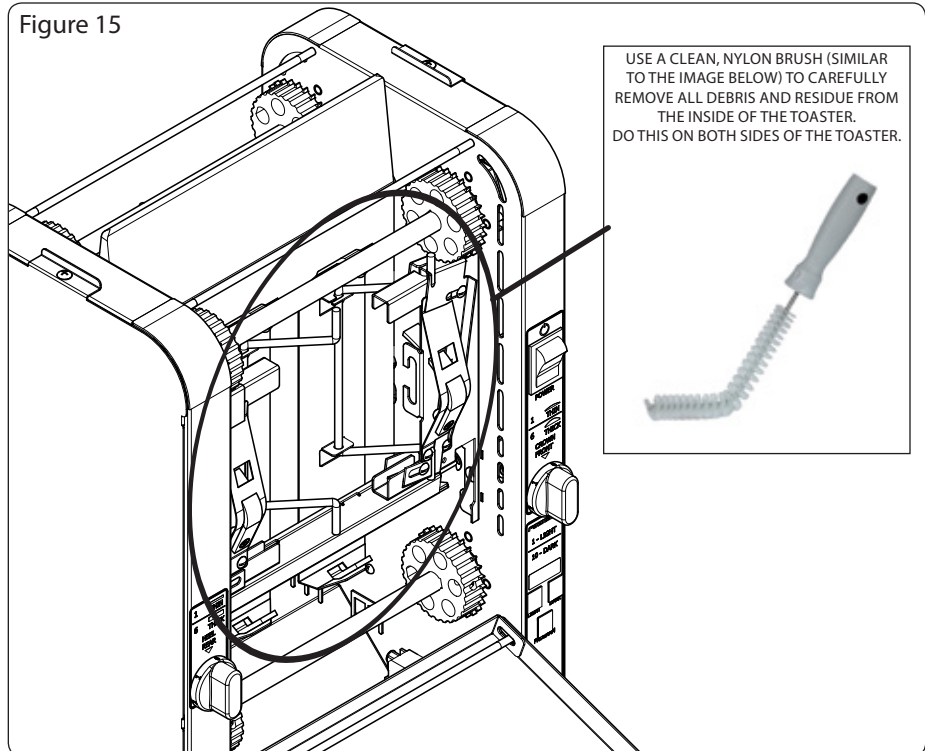

Figure 15



Replacing the Belt Wraps (Mfg. No. 9210907 Only)

The frequency of Belt Wrap replacement depends on usage and daily maintenance. We recommend replacing Belt Wraps Quarterly for optimal performance.

NOTE: Belt Wraps should feel sticky/tacky not slick/slippy.

1. Turn the unit off, unplug the power cord, and allow the unit to cool down.
2. Put on heat resistant gloves. Remove the Bun Feeder and Bun Chute (Figure 16). Set these items aside.
3. Set the Bun Thickness Compression Knobs to 6 and 6.
4. Next, open both Conveyor Covers (Figure 17).
5. Remove both Belt wraps - lift the flap on the Belt Wrap and pull the Belt Wrap Pin out of the zipper (Figures 18). Disconnect the Belt Wrap clips from the Conveyor Chain and remove the Belt Wraps from the toaster (Figure 18).

NOTE: If the pin is difficult to remove, cut the belts off carefully using scissors.

6. Install the new Belt Wraps onto the toaster under the yellow rods and making sure the flap is pointing down.
7. Attach the Belt Wrap clips to the Conveyor Chain.
8. Then, connect the ends of the Belt Wraps with the Pin, making sure the zipper teeth are properly aligned (Figure 19).

NOTE: Verify both clips are attached by pulling belt wrap away from chain and reattach if needed.

9. Close the Conveyor Covers.
10. Reinstall the Bun Chute and Bun Feeder and return the toaster to operation.

Cleaning the Rear Fan

1. Turn the unit off, unplug the power cord, and allow the unit to cool for 15 minutes before proceeding.

Figure 16

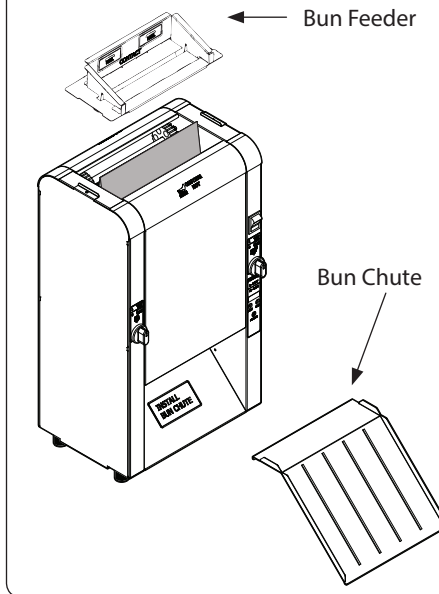
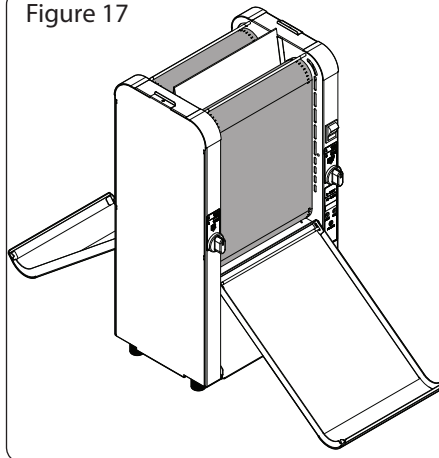

Figure 17



2. Refer to Figure 20. Remove the four Rear Panel screws circled and set aside.
3. Carefully remove the Rear Panel and lay it down so the fan is accessible.
4. Wipe inner surface of the Rear Panel and rear compartment with a clean, dry cloth to remove all debris and residue.
5. Use a clean, dry towel or a clean, nylon brush to remove all debris and residue from the Fan.
6. Reattach the Rear Panel and secure with the screws removed in Step 2.

Figure 18

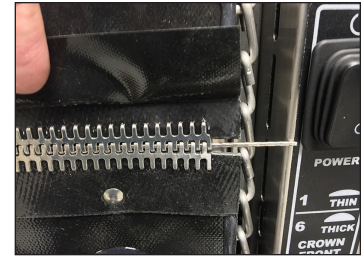

Figure 19

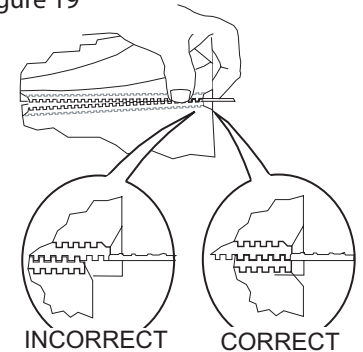
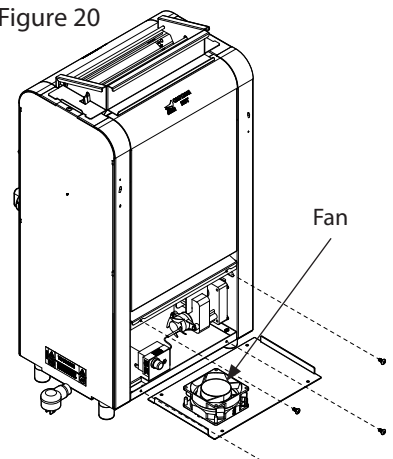
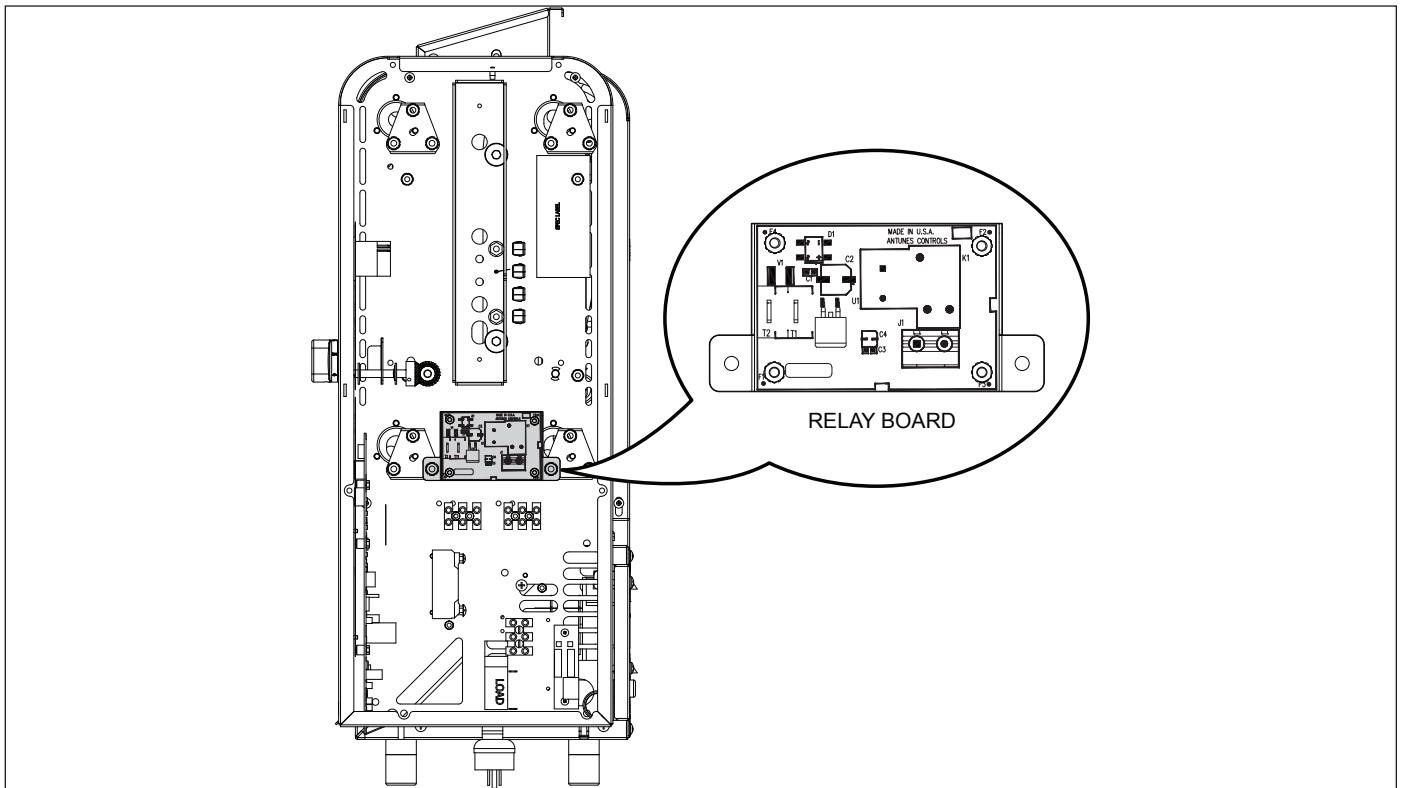
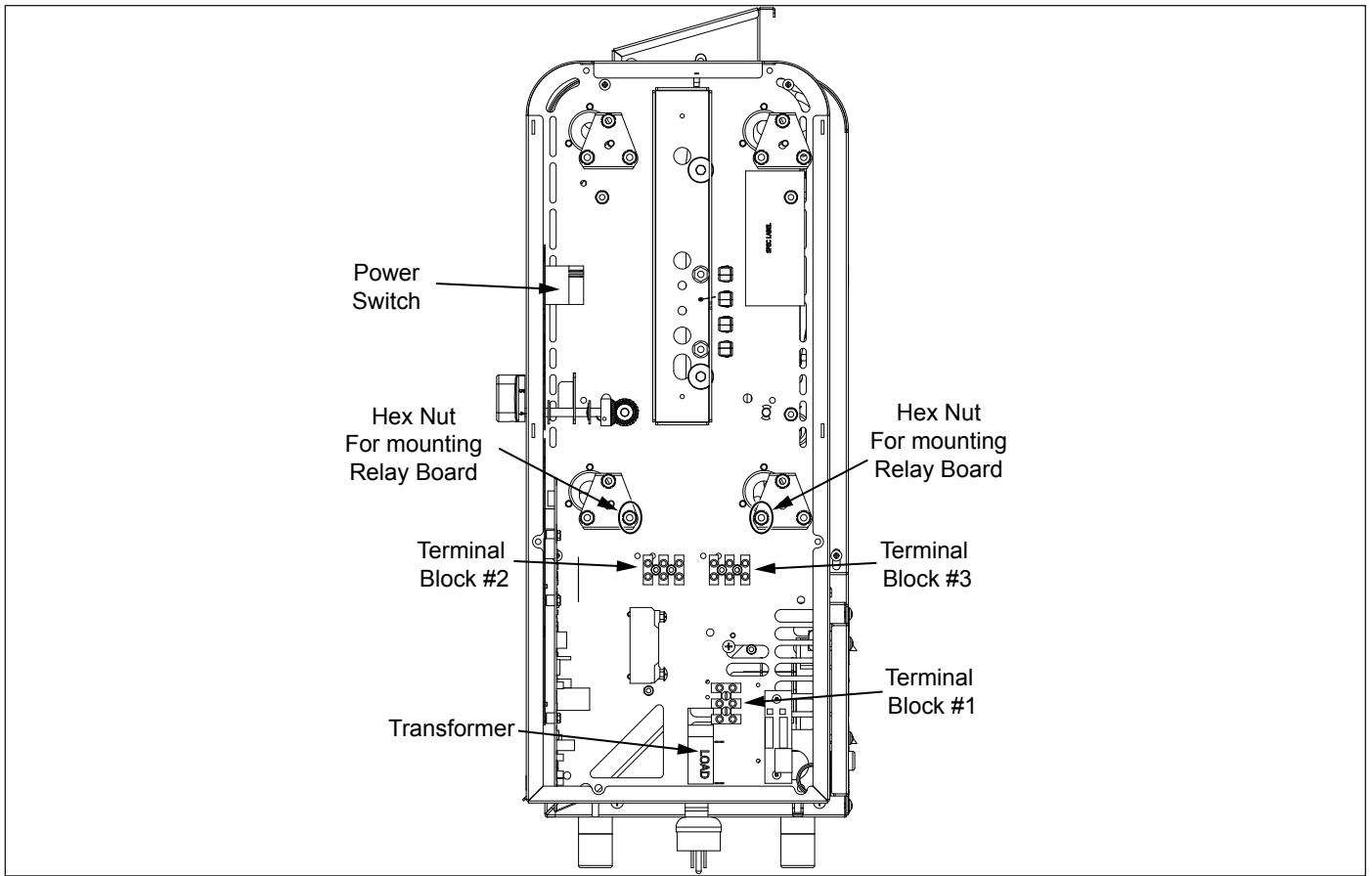

Figure 20



TROUBLESHOOTING

Problem	Possible Cause	Corrective Action
No Control Display	Power cord not plugged in	Plug power cord into the proper electrical outlet.
	Circuit breakers turned off or tripped. Damaged electrical outlet, plug, or cord. Power switch damaged	Reset circuit breakers. If they trip again, check the power cord, plug, and outlet for damage. Contact Antunes technical service, your maintenance person, or authorized service provider.
	Power Switch not turned on or is faulty.	Turn the unit off and then on again. If the problem persists, Contact Antunes technical service, your maintenance person, or authorized service provider.
	Faulty Transformer	
Conveyor does not rotate	Conveyor Belt/Chain has stretched. Chain skipping on sprockets.	Measure and adjust the conveyor belt chains as described in the Maintenance section of this manual.
	Loose setscrew on one of the drive sprockets	Contact Antunes technical service, your maintenance person or authorized service provider.
	Motor Drive Chain loose	Contact Antunes technical service, your maintenance person or authorized service provider.
	Internal part /object interfering within conveyor system	Check for interference & clear up as necessary.
Conveyor(s) skips or hesitates	Conveyor chains loose.	Measure and adjust the conveyor belt chains as described in the Maintenance section of this manual.
	Belt wrap clip not attached.	Verify both clips on each belt wrap are attached, reattach if necessary.
	Loose or misaligned sprocket	Contact Antunes technical service, your maintenance person or authorized service provider.
	Motor drive chain loose or stretched	Contact Antunes technical service, your maintenance person or authorized service provider.
	Drive motor(s) have failed	Contact Antunes technical service, your maintenance person or authorized service provider.
Buns not toasting adequately	Compression settings are incorrect.	Use recommended setting or adjust compression knobs as needed to achieve desired toast quality.
	Release sheet is worn or needs cleaning (replace every 2-4 weeks).	Inspect release sheet for cleanliness, worn spots, wrinkles, or tears. Clean or replace release sheet as described in the Maintenance section of this manual.
	Platen has butter/debris buildup.	Clean Platen as described in the Maintenance section of this manual.
	Light/Dark setting needs to be adjusted.	Adjust light/dark setting. See Operation section of this manual.
Crowns and/or Heels must be forced into the toaster. Buns sticking and burning.	Belt wraps are dirty, worn or damaged.	Clean or replace Belt Wraps as described in the Maintenance section of this manual.
	Platen has butter/debris buildup.	Clean Platen as described in the Maintenance section of this manual.
	Release sheet is dirty, worn or damaged.	Clean both sides or replace release sheet as described in the Maintenance section of this manual.
	Conveyor Chains loose.	Adjust the conveyor belt chains as described in the Maintenance section of this manual.
	Drive motor stalls intermittently.	Contact your Maintenance person or Authorized Service agency for service.
	Compression settings are incorrect.	Use the recommended settings or adjust as needed to achieve desired toast quality.
	Buns are not inserted into the toaster properly.	Insert Crowns in front conveyor with and Heels in rear conveyor. Cut side of buns need to face the platen.
Toaster making unusual sounds	Fan needs to be cleaned or replaced.	Clean fan as described in the Maintenance section of this manual or contact your maintenance person or authorized service company.
	Conveyor belt chains have stretched or adjusted incorrectly.	Adjust the conveyor belt chains as described in the Maintenance section of this manual.
	Motor Drive chain needs lubrication.	Lubricate chain.
	Conveyor shaft bearing is binding.	Contact your Maintenance person or Authorized Service agency for service.
Buns getting caught in bun chute area	Bun chute installed incorrectly	Reinstall Bun chute correctly.
Toaster displays ERR 10.	Internal temperature of control compartment exceeded 160° F.	Verify fan intake on back of toaster is clean, not blocked and has proper spacing. Clean cooling fan if needed, if not rotting, contact your authorized service provider. Check if cooling fan is functioning. If not, replace fan.
Toaster Displays ERR 11, 12,15 or 17.	Electrical failure.	Perform a factory reset. Ensure power switch is in off position and press and hold Up & Down arrow buttons together while turning power switch on. Display will show FR (factory reset). If Error code continues to display, contact Antunes technical service.



REPLACEMENT PARTS

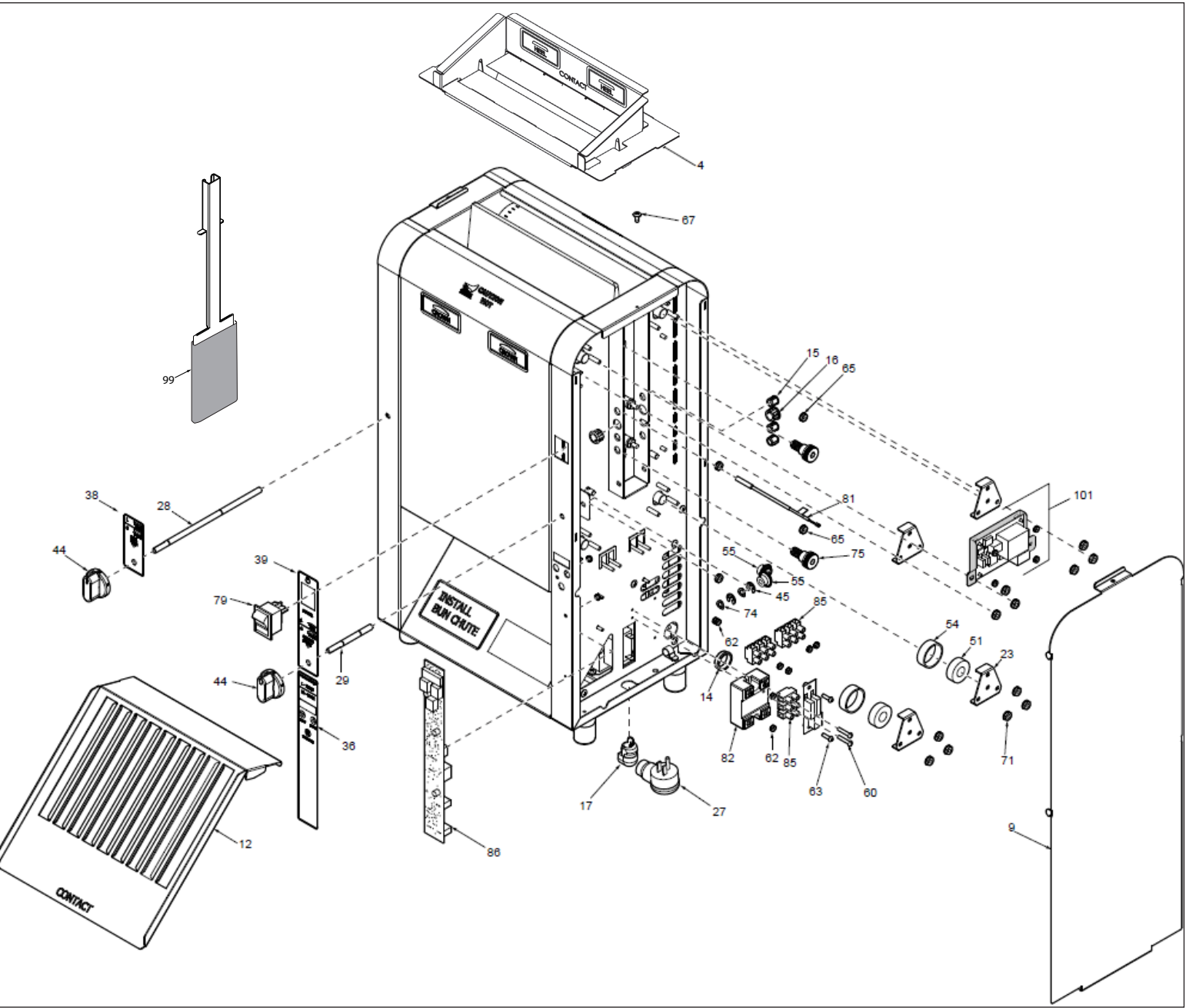

REPLACEMENT PARTS (CONTINUED)

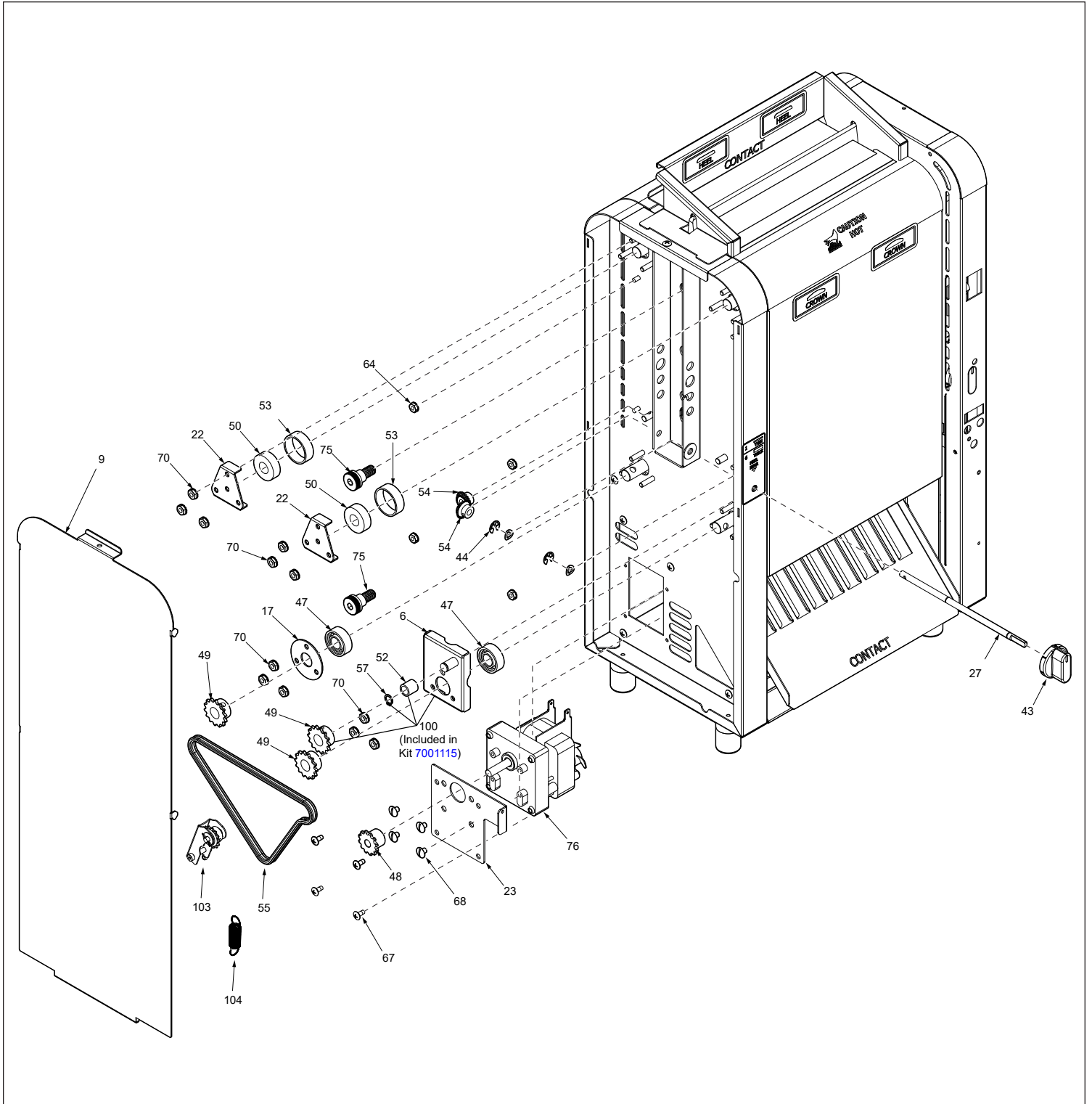

REPLACEMENT PARTS (CONTINUED)

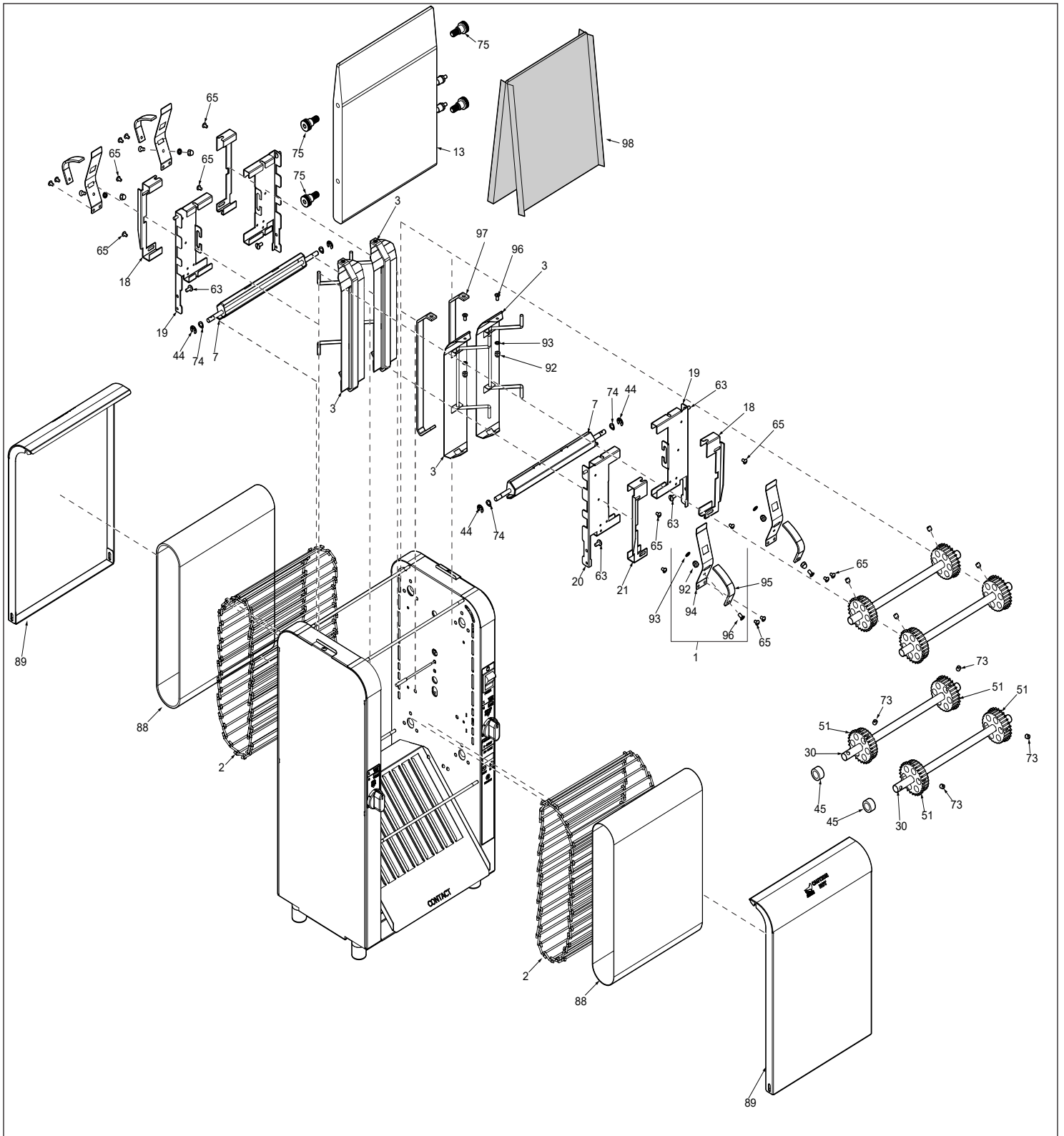

REPLACEMENT PARTS (CONTINUED)

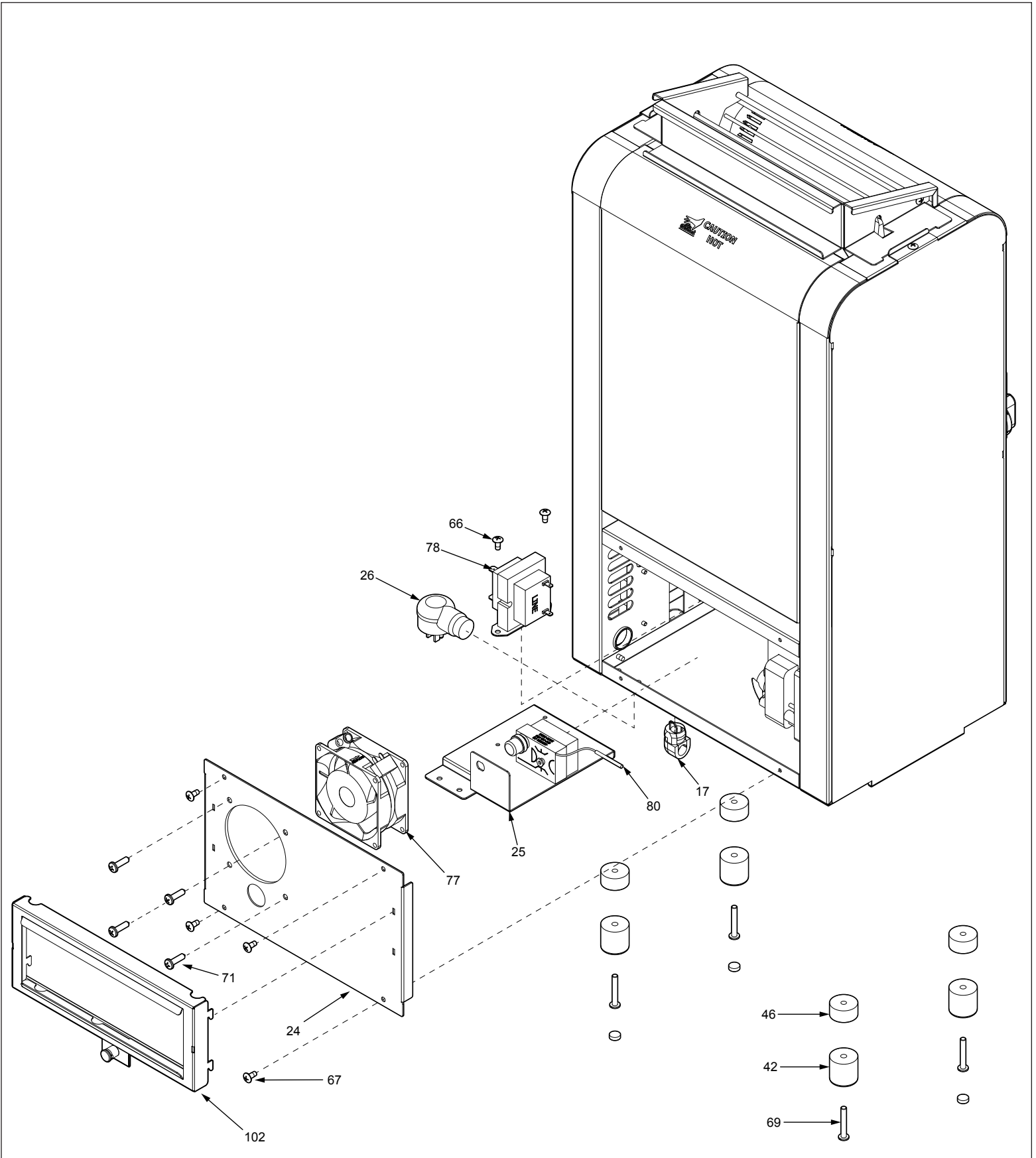

REPLACEMENT PARTS (CONTINUED)

Item Part No.	Description	Qty.	Item Part No.	Description	Qty.	Item Part No.	Description	Qty.			
1	0012472	Inner Spring Tensioner Assy.	4	39	1001556	Label, Wiring Diagram	1	72	325P104*	Washer, Flat 1/4" S/S	4
2	0012982	Conveyor Belt Assembly 37/2	2	40	1001592	Label, Chain Tensioning	1	73	325P163*	Set Screw, 1/4-28 X 5/16"	8
3	0012988	Tensioner Assembly	4	41	1031188	Spec Label	2	74	325P203*	Washer, Spring Steel Single-Wave	8
4	0012989	Bun Feeder Assembly	1	42	2100230	Bumper, Recess W/Washer	4	75	3380116	Screw, Shoulder 3/8-16 X 3/8 W/ 1/2 Shoulder	4
6	0021900	Idle Bearing Retainer Weldment (Incl. with kit 7001115 - Item 100)	1	43	2100348	Knob, 1/4" Shaft, Push-On	2	76	7001375	Drive Motor Kit 120V	1
7	0021959	Cam Weldment	2	44	2110127	Ring, Retaining	8	77	4000210	Fan, Axial 115V	1
8	0021960	Base Weldment	1	45	2120107	Spacer, Aluminum	2	78	4010199	Transformer, 120 Vac/12Vac	1
9	0021962	Control Panel Weldment	2	46	2120147	Spacer, Leg	4	79	7000882	Power Switch Repl. Kit	1
10	0021964	End Housing Weldment	1	47	7000296	Ball Bearing Kit (2-Pak)	1	80	4030332	Thermostat, Hi-Limit	1
11	0021965	Control Housing Weldment	1	48	2150173	Sprocket, 25B12 3/8" Bore	1	81	4050214	Thermocouple Type "K" (Open End)	1
12	0022040	Bun Chute Weldment	1	49	2150179	Sprocket, 25B14 1/2" Bore (1 Incl. with kit 7001115 - Item 100)	3	82	4051010	Relay, Random Phase, Solid State-50A	1
13	7000780	Platen, Grill 120V/1800W	1	50	7000224	Bearing & Retainer Kit	1	83	4060234	Wire Strap - 3/7"	1
14	0400147	Bushing, Shorty 7/8"	1	51	7000207	Sprocket Kit, 25B28 x 1/2" Bore Stepped Tooth	1	84	4060303	Bus Bar Contact 3-Pole	2
15	0400265	Bushing, Shorty 3/8"	4	52	2150258	Bearing, Idler (Incl. with kit 7001115 - Item 100)	1	85	4060355	Terminal Block, 3-Pole	3
16	0400437	Strain Relief, Rt Angle	1	53	2150260	Spacer, Bearing	6	86	7001005	Control Board Kit	1
17	0500464	Bearing Retainer	1	54	2150368	Miter Gear, 20° Pressure Angle	4	87	4070213	Varistor Board	1
18	0503495	Bracket, Retainer Right	2	55	2150370	Chain, Drive	1	88	7001158	Black Wavy Silicone Belt	1
19	0503496	Bracket, Tensioner-Right	2	56	2180145	Cover, Bumper	4	89	0021961	Conveyor Cover Weldment	2
20	0503497	Bracket, Tensioner-Left	2	57	3000124	Ring, Retaining 3/8" (Incl. with kit 7001115 - Item 100)	1	93	308P102*	Washer, Int. Tooth #09 Steel; Zinc Plated	4
21	0503507	Bracket, Retainer Left	2	58	304P105*	Nut, Hex 'Keps' #4-40	2	94	0505968	Spring, Inner Tensioner	4
22	0506755	Retainer, Bearing	6	59	306P121*	Screw, Mach #6-32 X 3/4"	2	95	7000780	Rail, Slide Kit (Small)	1
23	0508503	Plate, Motor	1	60	306P123*	Screw, Mach #6-32 X 7/8" Slrndhd	4	96	308P181*	Screw, Mach. #8-32 X 3/8" Lg Phflthd, 18-8 S/S Brt	4
24	0508370	Panel, Electrical	1	61	306P130*	Nut, Hex Keps #6-32 (Small Pattern)	8	97	7000779	Rail, Slide Kit (Large)	1
25	0507180	Bracket, Trx-Hi-Limit	1	62	306P156*	Screw, Mach. #6-32 X 1/2"	2	98	7000989	Sheet, Platen (Pk of 2)	1
26	0700925	Power Cord Right Angle	1	63	308P115*	Screw, Mach. #8-32 X 3/8"	8	99	7001126	Cleaning Tool Kit - VCT-2	1
27	0800455	Rod, Knob (Heel)	1	64	308P143*	Nut, Hex 'Keps' #8-32	8	100	7001115	Idler Sprocket Replacement Kit	1
28	0800457	Rod, Knob (Crown)	1	65	308P144*	Screw, #8-32 X 1/4" (#6 Head)	16	101	7001372	Relay Board Kit	1
29	0800458	Rod, Support	4	66	308P157*	Screw, Tap 8-32 X 3/8" Lg	4	102	7001602	Baffle Kit	1
30	0800460	Shaft, Drive	2	67	308P203*	Screw, Tap 8-32 X 3/8" W/Int. Tooth Washer	26	103	7001529	Drive Chain Tensioner	1
31	0800461	Shaft, Idler	2	68	310P103*	Screw, Mach. #10-32 X 1/4"	4	104	0600155	Compression Setting Spring	1
32	1000900	Label - Warning	1	69	310P136*	Screw, Mach. #10-32 X 1/4"	4	105	7001126	Platen Cleaning Kit (see pg 10)	1
33	1001181	Label, Crown	2	70	310P146*	Nut, Hex 'Keps' #10-32	24	106	7001932	Inner Tensioner Kit (2 pack)	2
35	1001550	Label, Control	1	71	310P213*	Screw, Phphnd #10-16 X 3/4" Thrd Form	4				
36	1001551	Label, Install	1								
37	1001552	Label, Cam (Heel)	1								
38	1001553	Label, Cam (Crown)	1								

*Available in Packages of 10 (ten).

NOTE: If your unit currently has the older styled roller tensioners attached to the covers of the unit, it is highly RECOMMENDED to eliminate the roller tensioner and upgrade to the newer Inner Tensioners.

#106 - P/N 7001932

NOTE: If a new cover is ordered it will NOT include the roller tensioners formerly attached to the inside of the covers. You will need to order the new inner tensioners to maintain proper tension of the toaster belts.

#106 - P/N 7001932

WIRING DIAGRAM

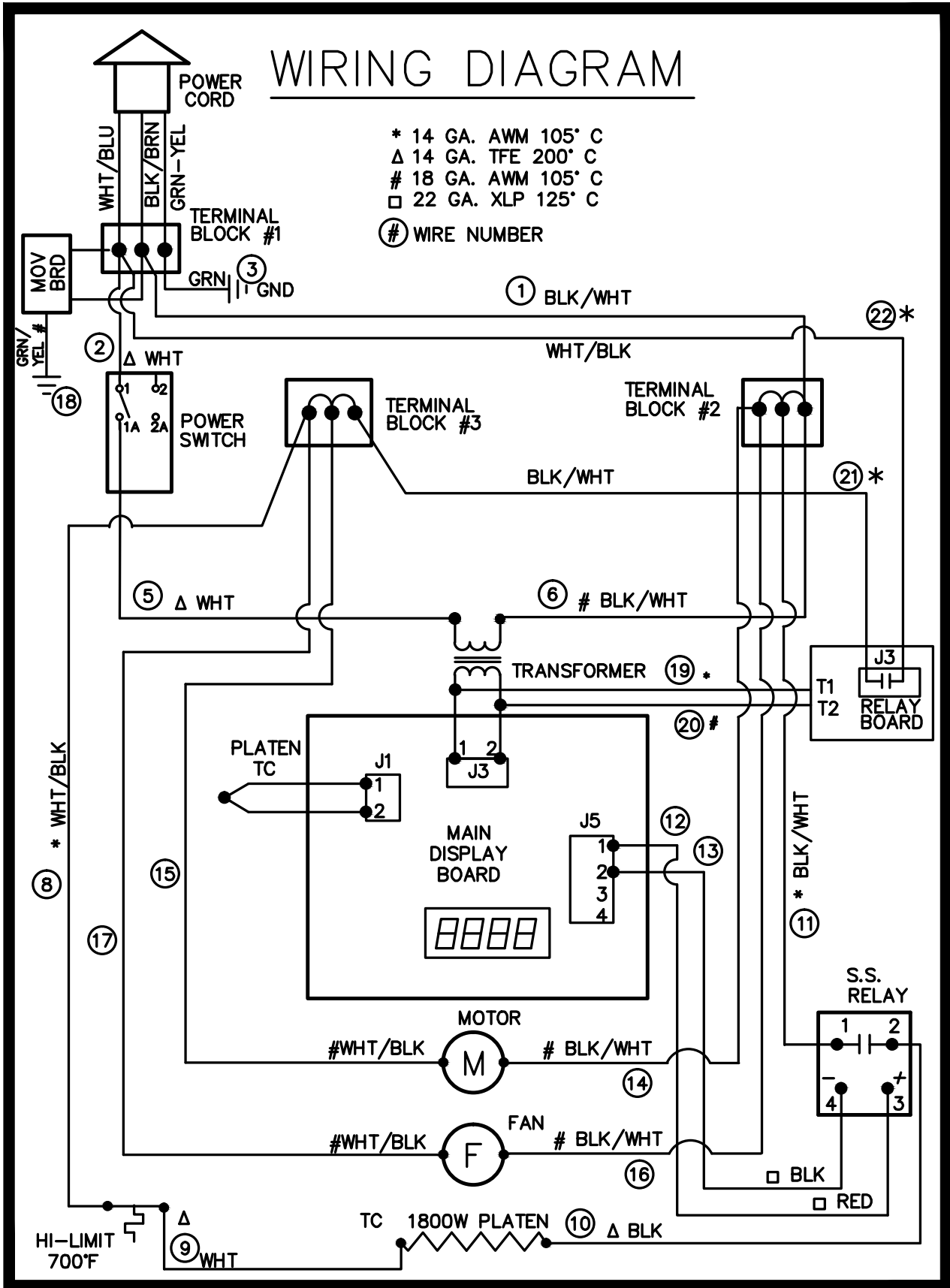

LIMITED WARRANTY

Equipment manufactured by Antunes has been constructed of the finest materials available and manufactured to high quality standards. These units are warranted to be free from electrical and mechanical defects for a period of two (2) years from date of purchase under normal use and service, and when installed in accordance with manufacturer's recommendations. To insure continued operation of the units, follow the maintenance procedures outlined in the Owner's Manual. During the first 12 months, electro-mechanical parts, non-overtime labor, and travel expenses up to 2 hours (100 miles/160 km), round trip from the nearest Authorized Service Center are covered. During the second year of this warranty (months 12 - 24), the following items are covered by a Part Only warranty: Drive Motor, Control Board, and Platen Heater.

1. This warranty does not cover cost of installation, defects caused by improper storage or handling prior to placing of the Equipment. This warranty does not cover overtime charges or work done by unauthorized service agencies or personnel. This warranty does not cover normal maintenance, calibration, or regular adjustments as specified in operating and maintenance instructions of this manual, and/or labor involved in moving adjacent objects to gain access to the equipment. This warranty does not cover consumable/wear items such as Release Sheets, Conveyor Belt Chain Link removal, Belt Wraps, and Dampers. This warranty does not cover damage to the Platen due to operating the toaster without a Release Sheet or cleaning with abrasive cleansers or tools, misuse or dropping of unit. This warranty does not cover problems or failures resulting from improper/incorrect voltage supply. This warranty does not cover Travel Time & Mileage in excess of 2 hours (100 miles/160 km) round trip from the nearest authorized service agency.
2. Antunes reserves the right to make changes in design or add any improvements on any product. The right is always reserved to modify equipment because of factors beyond our control and government regulations. Changes to update equipment do not constitute a warranty charge.
3. If shipment is damaged in transit, the purchaser should make a claim directly upon the carrier. Careful inspection should be made of the shipment as soon as it arrives and visible damage should be noted upon the carrier's receipt. Damage should be reported to the carrier. This damage is not covered under this warranty.
4. Warranty charges do not include freight or foreign, excise, municipal or other sales or use taxes. All such freight and taxes are the responsibility of the purchaser.
5. This warranty is exclusive and is in lieu of all other warranties, expressed or implied, including any implied warranty or merchantability or fitness for a particular purpose, each of which is hereby expressly disclaimed. The remedies described above are exclusive and in no event shall Antunes be liable for special consequential or incidental damages for the breach or delay in performance of this warranty.



Corporate Headquarters

Carol Stream, Illinois
Phone: +1 (630) 784-1000
Toll Free: +1 (800) 253-2991
Fax: +1 (630) 784-1650

China Facility

Suzhou, China
Phone: +86-512-6841-3637
Fax: +86-512-6841-3907