

**Aladdin Temp-Rite**<sup>®</sup>...better by degrees.

250 East Main Street, Hendersonville, TN 37075

1-800-888-8018 or 615-537-3600

Fax 1-888-812-9956

www.aladdintemprite.com

## Convect-Rite 3<sup>®</sup> INSIGHT<sup>™</sup>



### Docking Stations

*Mini 20/24 Meal Capacity (CRNDS4XXXXXX)*

*Junior 24 Meal Capacity (CRNDS0XXXXXX)*

*Senior 26/30 Meal Capacity (CRNDS1XXXXXX)*



Intertek



Intertek

Used with  
Convect-Rite 3 Cart manual 11067

U.S. Patent Number 7,025,121

Manual P/N 14196  
Rev. B 2/10/23

# INSTALLATION & SERVICE MANUAL



To start a manual heating cycle, press Manual Start and then the desired meal profile

The time the cart needs to be docked by for the next Heating. Displayed when in automatic heating mode.

Home screen when in automatic heating mode

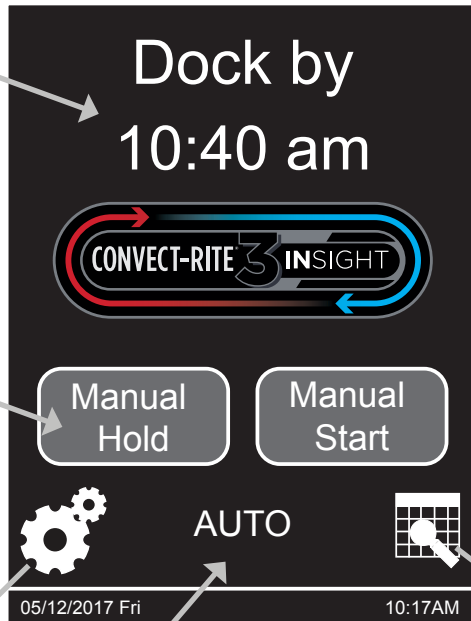

Manual hold will start the holding cycle of the meal profile to keep food warm & cold after heating.

passcode required



HOME button, takes you back to the home screen

BACK button, takes you back one screen

Mode displayed:  
 Auto: uses programed meal times  
 Manual: user starts heating cycle  
 Boost: user docks a cart, is prompted for a meal profile and heating cycle starts

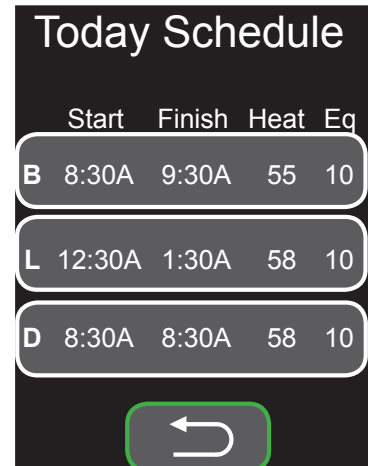
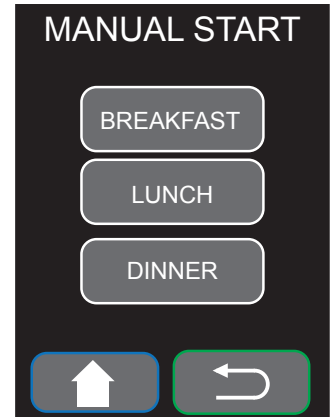

Today Schedule gives you an overview of the day. You can change the meal profile by pressing the meal and then entering a pass code

## Clear preventative maintenance alarm

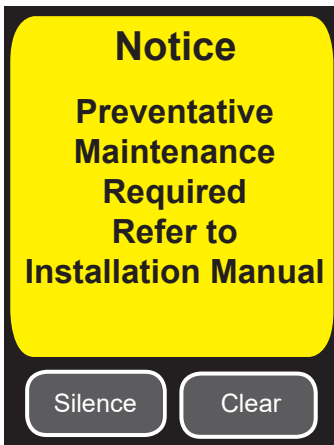

Any user can silence the reminder.  
To clear the reminder press "Clear"



Enter a level 3 or 4 pass code  
Press the ✓ check mark.

If an incorrect pass code is used or silence is press, the reminder will show up during the next cycle.

---

---

# CONTENTS

---

---

<b>CLEAR PREVENTATIVE MAINTENANCE ALARM</b>	<b>4</b>
<b>I. INTRODUCTION</b>	<b>6</b>
<b>II. RECEIVING INSPECTIONS</b>	<b>8</b>
<b>III. INSTALLATION INSTRUCTIONS</b>	<b>9</b>
INTRODUCTION	10
INSTALLATION POLICIES	11
ELECTRIC POWER REQUIREMENTS	11
SELECTING THE OPERATING LOCATION	11
<b>IV. PARTS LIST &amp; ILLUSTRATION</b>	<b>24</b>
PARALOOP/REMOTE ASSEMBLY ILLUSTRATION	27
<b>V. OPERATION &amp; PROGRAMMING</b>	<b>29</b>
SAFE-TEMP2 PARTS (OPTIONAL)	29
CLEARLINK PARTS (OPTIONAL)	29
<b>VI. PREVENTIVE MAINTENANCE</b>	<b>30</b>
INTRODUCTION	30
OPERATOR'S TROUBLESHOOTING	32
TROUBLESHOOTING NOTES	32
SERVICING PROCEDURES	38
REPAIRING THE REFRIGERATION SYSTEM	42
PUMP DOWN	42
MINI WIRING DIAGRAMS	44
JUNIOR & SENIOR WIRING DIAGRAM	50
EMERGENCY 9 VOLT CART RELEASE	57
<b>VII. WARRANTY</b>	<b>58</b>

# I. INTRODUCTION

## Convect-Rite 3® Insight™ Docking Stations

The Convect-Rite 3 Insight Docking Stations are installed and electrically connected in the food service pantry for a decentralized operation or grouped in one area for a centralized operation. Operation and programming of these units is shown in the Owners Manual. The Convect-Rite 3 Insight Docking Station is a dual cold and hot air-generator, which may be used up to three times a day in the Auto mode:

- To keep the meals at the recommended and safe temperature of 37/41°F (+3°C/+5°C) during stand-by periods prior to rethermalization.
- To rethermalize starters, soups, hot desserts or main-courses in approximately 50-60 minutes before service.
- **IMPORTANT NOTE:** The food products in the cold section, should be at maximum homogeneous 41°F (5°C) temperature when loaded inside the cart, so that the Convect-Rite 3 Insight System can keep them between 37 and 41°F (+3° and +5°C) at the end of the chill-down and rethermalization cycle.
- A minimum chill-down cycle of 50 minutes is recommended prior to rethermalization to assure the lowest possible cold food temperatures.

TABLE 1-1

DIM	CONVECT-RITE 3 INSIGHT SYSTEM MODELS	Mini Dock	Junior Dock	Senior
		20/24 Meal	24 Meal	26/30 Meal
	ALADDIN SALES CODE	CRNDS4XXXXXX	CRNDS0XXXXXX	CR3DS1X.XXXXX
A	DEPTH (OFF WALL FOR Docking Station)	33.5" (85 cm)	33.5" (85 cm)	33.5" (85 cm)
B	WIDTH	39.25" (99.70 cm)	39.25" (99.70 cm)	39.25" (99.70 cm)
C	HEIGHT	73.53 (186.7 cm)	77.39 (196.57 cm)	81.85"(207.90 cm)
	WEIGHT	450 lb (204 kg)	530 lb (204 kg)	573 lb (259.9 kg)
	SHIPPING WEIGHT	470 lb (213 kg)	550 lb (213 kg)	593 lb (268.9 kg)
	MAX HEAT REJECTION@ 70°F AMBIENT	7900 BTU/HR	7900 BTU/HR	9900 BTU/HR
	COOLING CAPACITY	6000 BTU/HR	6000 BTU/HR	7500 BTU/HR
	ELECTRICAL REQUIREMENTS	208V - 3 Phase - 60 HZ / 4 Wire - 30 Amp (Hard wire connection standard - cord & plug optional, 50 amp plug Senior)		

# SPECIFICATIONS

## CONVECT-RITE 3 Insight Docking Stations

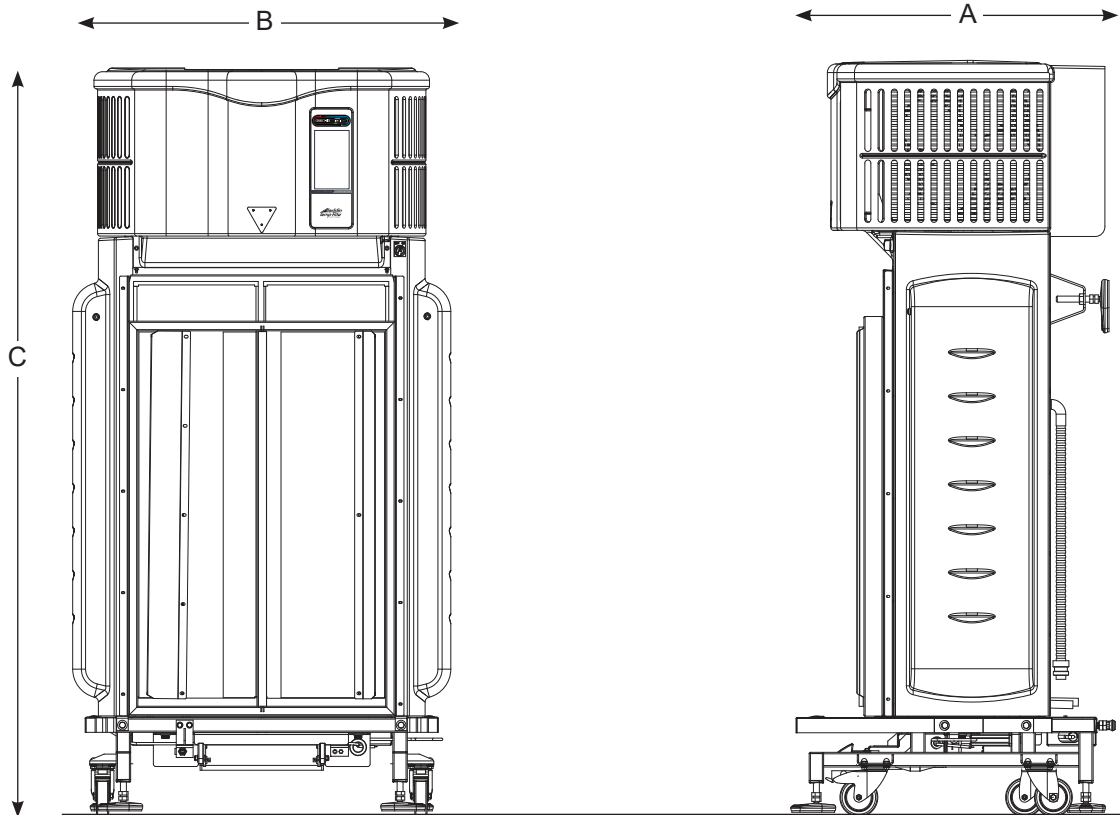

### MINI/JUNIOR MEAL - HEAT REJECTION

	AMBIENT TEMP (F)	HEAT REJECTION* (BTU/HR)
WATER COOLED	70°	2900
	85°	3000
	95°	3500
REMOTE	70°	2200
	85°	2200
	95°	2200

### SENIOR MEAL - HEAT REJECTION

	AMBIENT TEMP (F)	HEAT REJECTION* (BTU/HR)
WATER COOLED	70°	2900
	85°	3400
	95°	4300
REMOTE	70°	2200
	85°	2200
	95°	2200

\* During steady state operation, Contact ATR Tech Service for more details of unit heat rejections

## SERIAL / PRODUCT INFORMATION PLATES

During manufacture, Convect-Rite 3 Insight Docking Stations are assigned individual serial numbers. The serial number plate is located on the top left hand side of the black plastic top cover. The product information plate lists the model number, serial number, voltage, power and wiring requirements, amount and kind of refrigerant, pressure, and ETL listed mark.

# II. RECEIVING INSPECTIONS

---

Your Aladdin Temp-Rite Convect-Rite 3 Insight Docking Station is factory tested for performance and is free from defects when shipped. The utmost care has been taken in packaging this product to protect against damage in transit. All interior fittings have been secured to prevent damage.

The purchaser/user has the best knowledge and is in the best position to determine the operating conditions, appropriateness of the product for the operating environment, and safe use of the product. Aladdin Temp-Rite does not warrant, implied or expressly, that the product is fit for a particular use or operating environment.

You should carefully inspect your Convect-Rite 3 Insight Docking Station to assure that no damage has occurred in transit. If however, damage is detected, you should save all the packaging materials and make note on the carrier's Bill of Lading describing this shipment. A freight claim should be filed immediately. If damage is subsequently noted during or immediately after installation, contact the respective carrier and file a freight claim. Under no condition may a damaged unit be returned to Aladdin Temp-Rite without first obtaining written permission (return authorization).

### PACKAGING:

Your Convect-Rite 3 Insight Docking Station is packaged with care and shipped on dedicated carriers to you from the factory.

### IMPORTANT NOTE:

**Aladdin Temp-Rite does not recommend laying the Docking Station down on its front, side or back.** However, if you must, please be certain to allow the unit to remain in an upright position for 24 to 48 hours before attempting to place the unit into service, to assure that the compressor oils and refrigerant may settle.

### ALADDIN DAMAGED GOODS POLICY

There are two types of damaged merchandise:

- Visual Damage
- Concealed Damage

---

---

Visual Damage – When the product being received is visibly damaged.

1. Receiver should not accept merchandise with visual damage.
2. Receiver must sign delivery receipt “refused merchandise due to damage” and specify damage.
3. Receiver should call Aladdin Customer Service immediately after refusal.
4. Carrier will notify Aladdin Traffic Department and a claim will be filed.
5. Carrier will send acknowledgement of claim within 7 days after receiving.

Concealed Damage – When damaged merchandise cannot be externally detected.

Any receiving operation should be looking for this type of damage. Sometimes, depending on the type of product, it is almost impossible to notice.

1. Merchandise must not be removed from point of delivery and all packaging must be kept intact.
2. Receiver must contact Aladdin customer service to report damage.
3. Aladdin traffic department will request inspection based on the dollar value of the cargo.
4. Aladdin traffic department will file a claim based on the findings of the inspection.

Failure to comply with these policies will result in the customer’s responsibility to file claims.



## III. INSTALLATION INSTRUCTIONS

---

### IMPORTANT NOTE:

**DO NOT INSTALL** a Convect-Rite 3 Insight Docking Station if damage is suspected.

**INJURY & EQUIPMENT DAMAGE** could result from improper installation of the Convect-Rite 3 Insight Docking Station or from installation of a unit damaged during shipment or storage. **Either of these conditions will void the equipment warranty.**

 <b>WARNING</b> 	
	<b>DO NOT</b> move a Convect-Rite 3 Insight Docking Station up a slope greater than 10°.
	<b>NEVER</b> tow a Convect-Rite 3 Insight Docking Station
	<b>DO NOT</b> push a Convect-Rite 3 Insight Docking Station from the front or back side

### ⚠ CAUTION ⚠

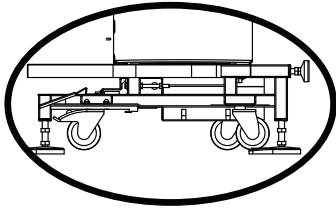

Casters are **ONLY** intended for use during **transport, installation or service**.

Unit **MUST** be positioned securely against a wall during operation!

## INTRODUCTION

Install the Convect-Rite 3 Insight Docking Station according to the policies and procedures outlined in this manual. After selecting and preparing the Convect-Rite 3 Insight Docking Station operating location, the unit can be positioned and installed. When installation is complete, perform all start-up checks to verify proper installation and operation.

This section is a guide for installation of the Convect-Rite 3 Insight models identified in the Introduction section of this manual. This guide is for use by qualified professionals and does not include all procedures and precautions in the common domain of licensed plumbers, pipe fitters, and electricians or experienced food service equipment installers.

This guide **MUST** be used in conjunction with professional experience and thorough understanding of the local and national utility, construction & sanitation codes.

**Before starting installation, the owner and the installer should read through this chapter and thoroughly understand and agree upon:**

- The installation policies of Aladdin Temp-Rite® as stated in Installation Policies Section.
- An installation plan based on the Installation Instructions and Start-Up Check List.

---

---

## INSTALLATION POLICIES

The Convect-Rite 3 Insight Docking Station must be installed by qualified electrical, mechanical, or refrigeration personnel, working to all applicable national and local codes. Equipment installation must comply with the local and national codes.

- All models of the Convect-Rite 3 Insight Docking Station comply with the applicable standards for manufacturers. Included among those certification agencies are: ETL Safety and ETL Sanitation.
- The Convect-Rite 3 Insight Docking Station is certified for safe operation only when permanently installed in accordance with local and/or national codes. Many local codes exist and it is the responsibility of the owner and installer to comply with these codes.
- In no event shall Aladdin Temp-Rite assume any liability for damage or injury resulting from installations which are not in strict compliance with the Installation Instructions and the codes cited above. Specifically, Aladdin Temp-Rite will not assume any liability for damage or injury resulting from improper installation of equipment, including but not limited to temporary or mobile installations.

## ELECTRIC POWER REQUIREMENTS

Docking Station should be hard wired or cord & plug to electrical disconnect requirements specified which can also be found on the product identification plate. The plate is secured to the top on the left hand side as you look at the front of the unit as mentioned in serial/product information plate section. 208 volts / 3 phase / 30 amp circuit / 4 wire (3 hots & 1 ground) Cord and plug connection is optional but may require a larger circuit.

## SELECTING THE OPERATING LOCATION

For safe and efficient operation, observe the following criteria when selecting an operating location for the Convect-Rite 3 Insight Docking Station.

### **IMPORTANT NOTE:**

The flooring directly under this unit must be made of non-combustible material and be capable of supporting the weight of this equipment.

1. Do not install these units in areas where combustibles are stored or may accumulate. The surrounding area must be clear of combustibles, including the space under the unit.
2. A proper air supply for ventilation is critical to safe, efficient operation of the Docking Station. The area around the Docking Station must have adequate ventilation and the ambient temperature should never be above 85°F (35°C).
3. Do not block the louvers or panels. Do not install any heat producing equipment near the louvers of the unit. Ventilation occurs through open slots on the dock's right side and through louvers on the back of the unit.
4. The dimension drawings in Figure 3-1 specify all dimensions and clearances required for proper installation, operation and, service of the Convect-Rite 3 Insight Docking Station covered in this manual. **The front and rear door swing of the cart is 30" (750 cm).**

5. The condensing unit and controller can be accessed by removing the black plastic top cover. Removable side panels provide access for service of various components; the right side for the cold side blowers and electrical panel and the left side for the hot side motors. The back access panel permits service to the cold side motors and expansion valves. Removing the front assembly allows access to the hot side heaters and blowers. **A minimum 6" (15.16 cm) clearance is required on both sides of the unit.** For access to the back and side panels the Docking Station should be lowered onto the casters and pulled away from the wall where it can be turned 90°-180° for ease of service.
6. The location selected must be capable of supporting the operational weight of the Convect-Rite 3 Insight system including the weight of the Convect-Rite 3 cart loaded with trays, crockery, and food-products. See Table 1-1 for equipment weights.
7. **The floor surface under the docking station must be level and continuous with the flooring in front of the unit.** The cart must roll smoothly to the Docking Station for ease of operation and maintenance of the seal between the Docking Station and the cart.

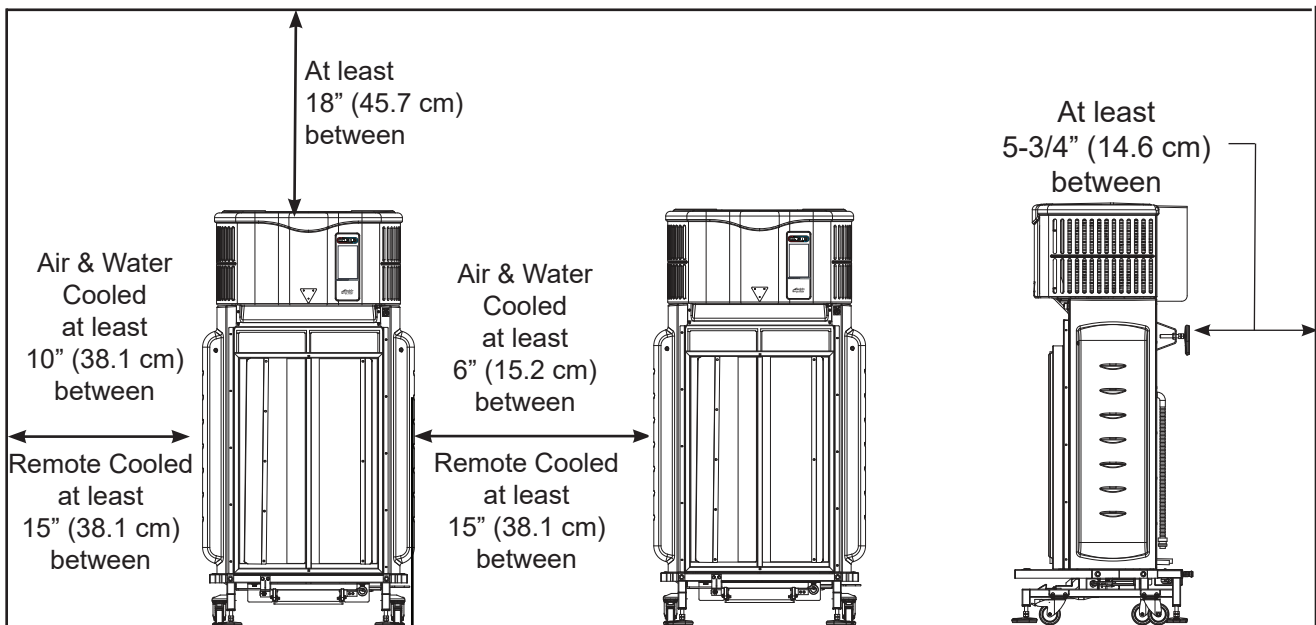

**Figure 3-1**

## WALL MOUNTING INSTRUCTIONS

### IMPORTANT NOTE:

The wall directly behind the Docking Station must be able to support the average cart docking force of 550 lbs. Based on the condition of the support wall, a reinforcing horizontal or vertical brace may be required at the upper and lower wall contact points, for better stability. See figure below for details.

Support braces should be:

- 1) 2" x 6" X 3'  
SPIB Southern pine wood or equivalent
- 2) 8" X 3'  
10 Gauge 304 Stainless steel or equivalent
- 3) Use optional Aladdin wall mounting kit PN 98507

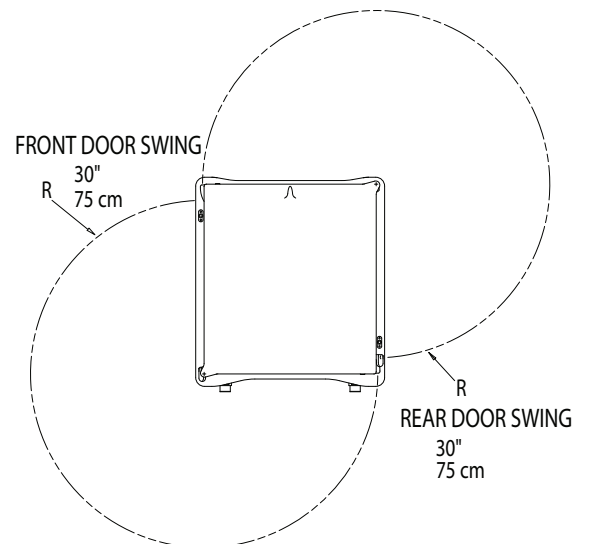
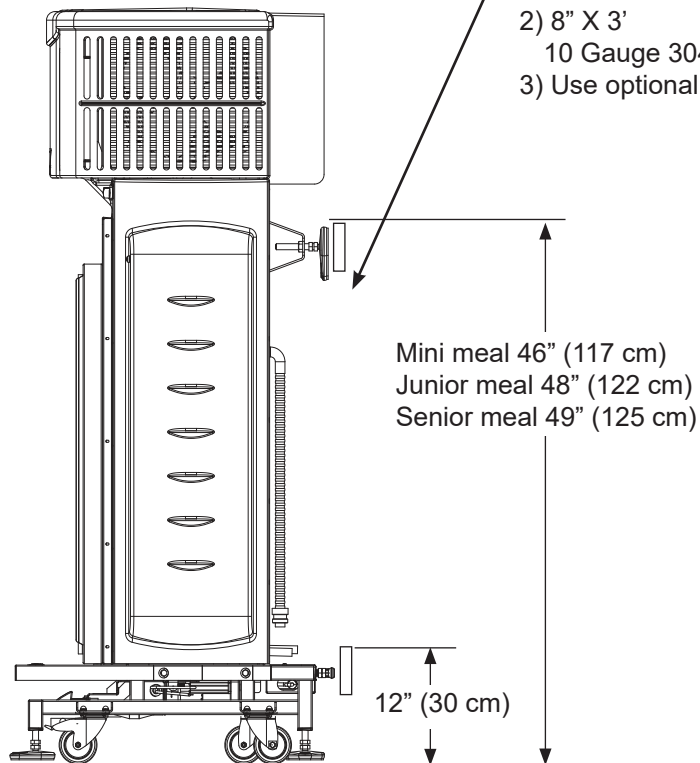

## WATER-COOLED REQUIREMENTS

The Aladdin water-cooled condensing unit has a tube-in-tube type spiral water-cooled condenser coil. The compressor is a refrigerant-cooled compressor. The water-regulating valve on the condensing unit has been factory preset to regulate the high side pressure at 250 PSI +/- 10 PSI (or 105°F). The allowable working pressure of water valves is normally 150 PSI. If in excess, a pressure reducing valve must be used.

The optimum operating conditions for the water-cooled condensing unit as suggested by the original manufacturer requires a maximum inlet water temperature of 75°F with a 20°F exiting temperature differential. The graphs below list alternate gallons per minute (GPM) values vs. incoming water temperature for the designed evaporative temperature of 10°F and 15°F for the 20/24 (Mini & Jr) and 30 (Sr) models. Use these values to determine the GPM required when 75°F incoming water temperature is not available. Table 3.1 lists the exiting water temperature differential vs. the incoming water temp when 75°F incoming water is not available.

The flexible hose running from the supply loop to the inlet valve on the 20/24 & 26/30 Meal Docking Stations should be at least 5 feet long, 3/8" MIN ID (9.5 mm), 3/8" female NPT connection and water pressure rating of 300 PSI.

The flexible hose running from the outlet of the 20/24 & 26/30 meal Docking Stations to the waste or recycle loop should be at least 5 feet long, 3/8" MIN ID (9.5 mm), 3/8" female NPT connections and a water pressure rating of 300 PSI.

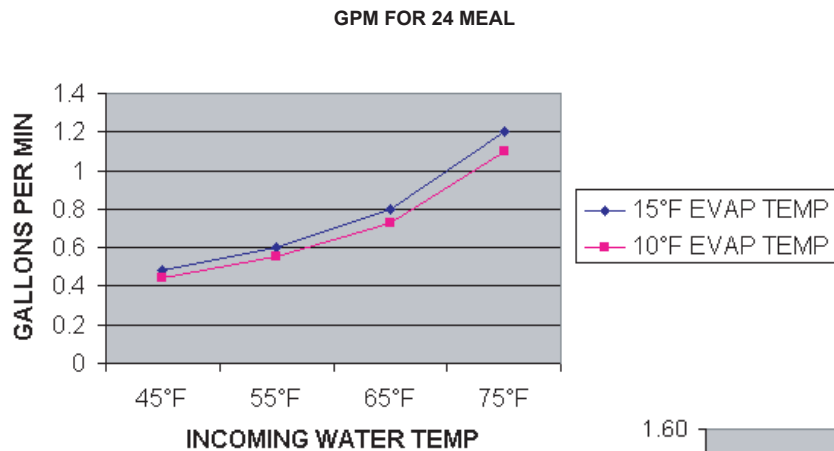

**NOTE:**  
**GPM rates shown are with a steady state 10°F or 15°F coil. Flow rates requirements at start up will be higher.**

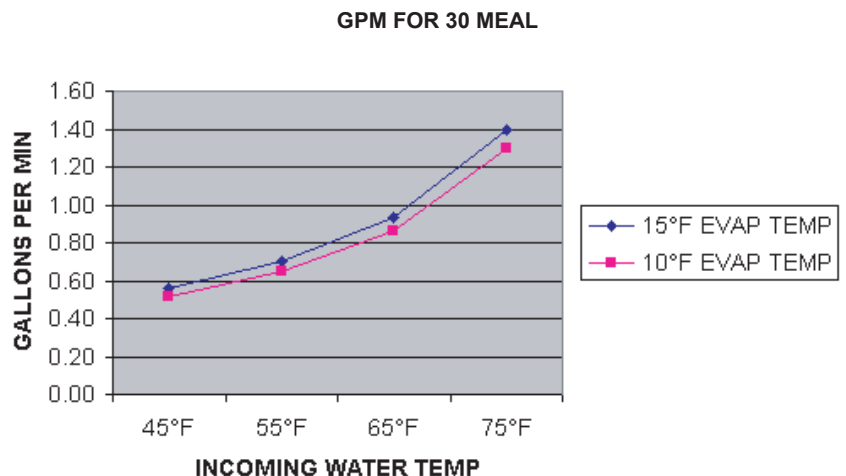

TEMPERATURE DIFFERENTIAL vs INCOMING WATER TEMP				
INCOMING WATER TEMP	45°F	55°F	65°F	75°F
WATER TEMP DIFFERENTIAL EXITING CONDENSER	50°F	40°F	30°F	20°F

**Table 3.1**

**Water cooled connections**

	Mini MEAL		Junior MEAL		Senior MEAL	
	INLET	OUTLET	INLET	OUTLET	INLET	OUTLET
ELEVATION FROM FLOOR	62.5"	66.5"	70.3"	66.4"	75"	71"
CONNECTION SIZE	3/8" Male NPT					

**Table 3.2**

**Remote cooled connections**

	Mini MEAL		Junior MEAL		Senior MEAL	
	SUCTION	DISCHARGE	SUCTION	DISCHARGE	SUCTION	DISCHARGE
CONNECTION SIZE	7/8"	3/8"	7/8"	3/8"	7/8"	3/8"
VERTICAL ELEV FROM FLOOR	59.7"	59.7"	63.8"	63.8"	68.2"	68.2"
HORIZ DIM FROM RIGHT OF DOCKING STATION (looking at the front of the unit)	27"	19"	27"	19"	27"	19"

**Table 3.3**

**INSPECTED FOR SHIPPING DAMAGE** (see Section II. RECEIVING INSPECTION)

**CONNECT ELECTRICAL LINE**

Electrical schematic diagrams can be found in Section VI. *PREVENTIVE MAINTENANCE*. Connect the electrical cord to the electric connection box as described in image below. Refer to Table 3-1 for amperage distribution or plug the cord into the wall outlet if so equipped.

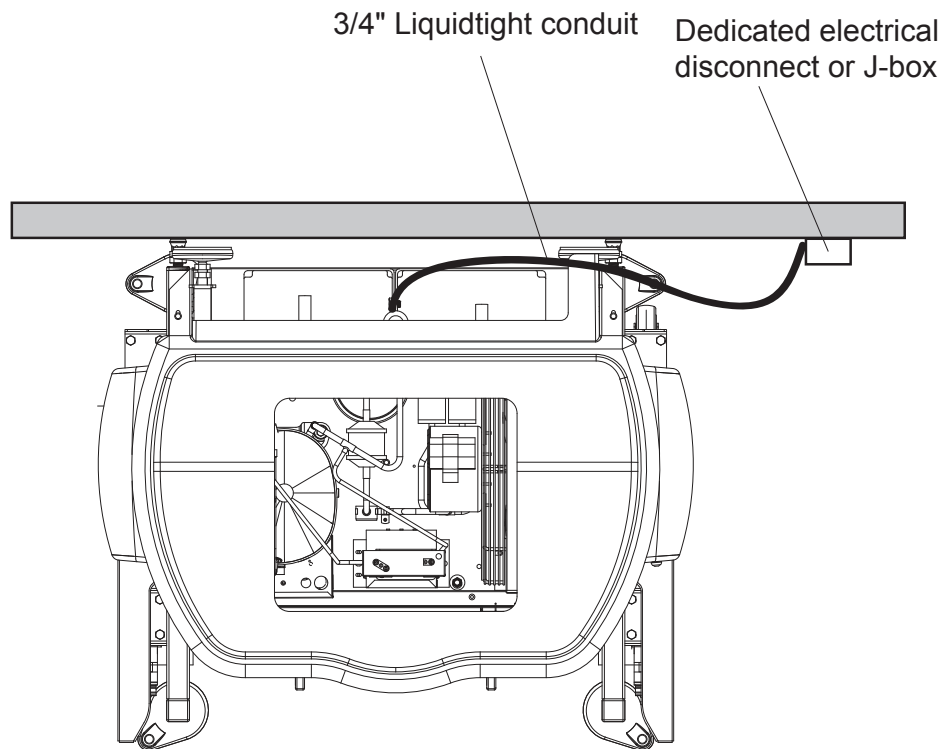

<b>Table 3-1</b>				
<b>Convect-Rite 3 Insight Docking Stations</b>				
208V / 3PH / 4 wire/ (3 hot, 1 ground) / 60 HZ	Mini & Junior 20/24 Meal Unit		Senior 26/30 Meal Unit	
	Power Watts	Amps	Power Watts	PH1 Amps
Product Total	<b>9.3 kw MAX*</b>	24	<b>10 kw MAX*</b>	28

\*Actual duty load during rethermalization cycle is approximately 75% of maximum power requirements. Cord and plug is optional and may require a larger circuit.

## ✓ TEST BOOT

With the unit still on all four casters, and after the hard wire connection is complete, switch the breaker on for the unit. Turn on the unit (the switch located on the upper right front of the unit). The unit should boot up and the screen should display the time and Idle (see figure to right). Turn the unit and breaker off. If the unit does not boot correctly check electrical connection. For further information call Aladdin Tech Service 1 (800) 888-5426.



## ✓ SETTING AGAINST THE WALL

Make adequate space and thoroughly clean the location before you begin the install. The Docking Station has eight adjustable feet (four on the back & four on the bottom). When starting the install process all eight feet should be completely seated. Gently push unit within 1/4" of the wall. Loosen the 5/8" jam nuts on the back four feet. Adjust all four back feet close to the wall but not touching it. Extend one foot at a time to touch the wall, trying to keep the unit parallel to the wall as possible (due to wall inconsistency all four feet may need to be adjusted to different lengths) NOTE: Recommend adjusting the top feet until the Docking Station sits at a 5° angle away from the wall as a starting position.

## ✓ LIFTING THE UNIT OFF THE CASTERS

**NOTE: If feet are unevenly set the unit's frame may be damaged by racking.**

The Convect-Rite 3 Insight Docking Station **MUST BE LEVEL BOTH FRONT TO BACK AND SIDE TO SIDE**. Depending on floor condition, reference gasket alignment between the cart and Docking Station to insure proper gasket seal for correct positioning.

Ensure that both caster locks point away from the wall, and are 90° to the wall in the locked position.

Make sure the four feet on the base of the Docking Station are attached and adjustable to achieve the proper height. Be mindful when setting the feet that:

- A Docking Station set too low can result in interference between the lower cart hinge and the Docking Station interface channel. Care should be taken to not set the dock too high otherwise the gasket will not seal correctly.
- A Docking Station set out of level right-to-left can result in an insufficient seal between the unit and the gaskets on the cart.
- A Docking Station set out of level front-to-back can result in an insufficient seal between the unit and cart and possibly make mating the cart more difficult.

Loosen the 5/8" jam nuts on the four bottom feet. Then adjust the four feet close to the floor, but not touching it. Slowly continue to extend each foot a turn at a time, until the top of the interface is 11.25" (see diagram) off the floor (the caster should be off the floor at this point). However, due to floor inconsistency, all four feet may need to be adjusted to different lengths

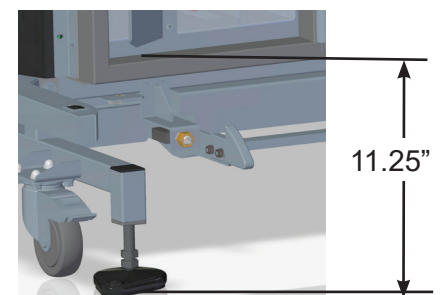

## ✓ EXTENDING THE REAR FEET AGAINST THE WALL

**NOTE:** Shims should NOT be used.

Adjust back feet until they are tight against the wall. Check that the feet are not bowed, skewed, or have fewer than 3 threads protruding from rear brackets. If any of these conditions occur, the dock should be lowered back on its casters and moved closer to the wall.

## ✓ ADJUSTING THE SEAL & LATCHES

Turn on the dock. Roll a Convect-Rite Retherm Cart up to the front of the Docking Station with the door open on the non-handle end of the cart. **NOTE:** if Docking Station is set too low the cart will run into the door support. If the cart does not hit the door support, dock the cart to the unit. The Dock will pull the cart up to it. Adjust feet, if necessary, until a uniform compression seal is formed around the cart. You may need to dock & undock the cart several times to ensure a proper fit.

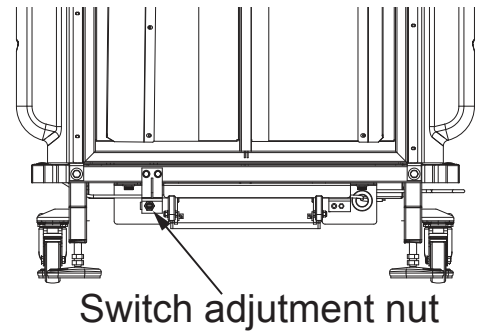

Tighten ALL 5/8 " jam nuts for extended use.

If a docking error occurs more than once, adjust nuts on the cart present switch in or out as needed.

## ✓ MOUNTING TO THE FLOOR

The Docking Station should be secured to the floor with floor anchors. Turn the rubber feet out 45°, for better stability. Select a carbide drill bit equal to the anchor diameter, 1/2". Drill hole to desired depth suitable for the floor type. A minimum embedment of 1-7/8" is required for concrete. Clean hole or continue drilling additional depth to accommodate floor finish. Assemble washer and nut, leaving nut flush with end of anchor to protect threads. Drive anchor through the foot until the washer is flush. Expand anchor by tightening nut 3 to 5 turns past the hand tight position, or 25 ft-lbs. torque.

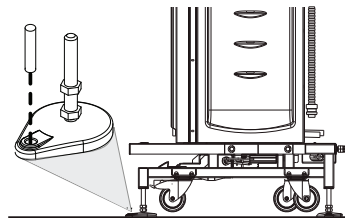
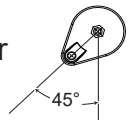

---

---

## STARTUP CHECK LIST

This inspection checks for proper electrical wiring to the Convect-Rite 3 Insight Docking Station and verifies basic operation of the unit.

### **IMPORTANT NOTE:**

Equipment damage and faulty operation will result if electrical supply falls below requirements. This may be caused by other equipment on the same supply line. **Supply a dedicated electric service for each unit.**

- Refer to the appropriate dimension drawing and verify that the specified clearances are met (Fig 3.1).
- Verify that the voltage supplied complies with the voltage requirements specified on the Product Identification Plate located on top of the unit. Verify that the wiring connections are correct for these voltage requirements.
- Turn the unit power-switch to the “on” position. **After a 5 second delay**, fan-motor rotation should start.
- Connect the Convect-Rite 3 Insight Cart to the Convect-Rite 3 Insight Docking Station with both cart doors opened. (check air blowing on both sides)
- Operate a complete cycle (make sure door opposite Docking Station is closed) to check every function of the Convect-Rite 3 Insight unit. Temperatures set points for the cold and hot sections are pre-set at the factory. Both can be adjusted to meet customer’s requirements. (Refer to **Section V of the owners manual for programming instructions**)
- Verify cold air blowing and hot air ventilation functions.

### OPTIONAL WALL MOUNT

#### BACK MOUNTING BRACKETS



Remove lower cane tips from dock.

Add the wall mounting bracket (98076) to the dock from the mounting kit PN 98674.

Wall Mounting Brackets

Remove Feet

#### STANDARD UPPER MOUNTING ASSEMBLY

Step 1: To secure top horizontal support channel see Figure 3-2. Confirm  $1\frac{5}{8}$ " x  $1\frac{5}{8}$ " Unistrut channel is level and fasten to vertical wall surface using appropriate fastening devices for wall surface encountered to insure equipment stability.

Step 2: Measure  $6\text{-}5/8$ " from center of "Unistrut" channel down to center of lower channel and fasten to wall surface as directed above.

This "Unistrut" assembly will serve as an attachment point for the wall mounting hardware detailed in Figure 3-3.

Note: Utilize an 8'-0" span of "Unistrut" when mounting two Docking Stations adjacent to one another, and maintain 6" between air & water cooled unit, 15" between remote cooled units for serviceability.

Step 3: Assemble mounting hardware to support brackets located at the rear of Docking Station and fasten to "Unistrut" support channel assembly previously described and detailed in Figure 3-3.

Note: Fasten Floor Mounts only after unit has been adjusted for proper fit and seal with retherm cart.

#### OPTIONAL LOWER MOUNT:

If a lower mount assembly is utilized then the following instructions apply. The lower wall mount is identical to the upper mounting assembly see Figure 3-2.

---

---

## POSITION & LEVEL THE Convect-Rite 3 Insight Docking Station

1. The Convect-Rite 3 Insight Docking Station **MUST BE LEVEL BOTH FRONT TO BACK AND SIDE TO SIDE**. Depending on floor condition, reference gasket alignment between the cart and Docking Station to insure proper gasket seal for correct positioning.
2. The floor must be flat and smooth.
3. Make adequate space and thoroughly clean the location.
4. Leave the minimum clearances (see Figure 3-1) on each side of the Docking Station for better ventilation and access for technical service.

The unit **must** sit level on a level floor. The unit must be level both front-to-back and right-to-left. The four lower Docking Station feet are adjustable to achieve this. Be mindful when setting the feet that:

- A Docking Station set too low can result in interference between the lower cart hinge and the Docking Station interface channel.
- A Docking Station set out of level right-to-left can result in an insufficient seal between the unit and the gaskets on the cart.
- A Docking Station set out of level front-to-back can result in an insufficient seal between the unit and cart and possibly cause mating a cart to be more difficult.

Open the door of the Convect-Rite 3 Insight Cart opposite the handles and mate the cart to the Convect-Rite 3 Insight Docking Station. Confirm that the cart gasket seals against the Docking Station's interface channel around its full perimeter. Make the proper adjustments to the Docking Station if the mating is not correct. Once the Docking Station level is set, tighten all wall 5/8" jam nuts to final torque settings. Once the Docking Station is secure, anchor the unit to the floor. If cart does not latch properly adjust latch position (see "Adjusting the latches")

## MOUNTING TO THE FLOOR

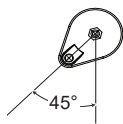

The dock should be secured to the floor with the floor mounting brackets. Turn the feet out 45°, for better stability. Select a carbide drill bit equal to the anchor diameter, 1/2". Drill hole to desired depth suitable for the floor type. A minimum embedment of 1-7/8" is required for concrete. Clean hole or continue drilling additional depth to accommodate floor finish. Assemble washer and nut, leaving nut flush with end of anchor to protect threads. Drive anchor through the foot until the washer is flush. Expand anchor by tightening nut 3 to 5 turns past the hand tight position, or 25 ft-lbs. torque.

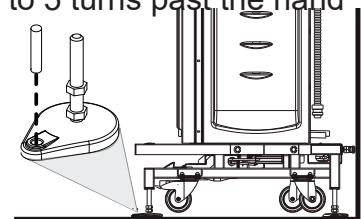
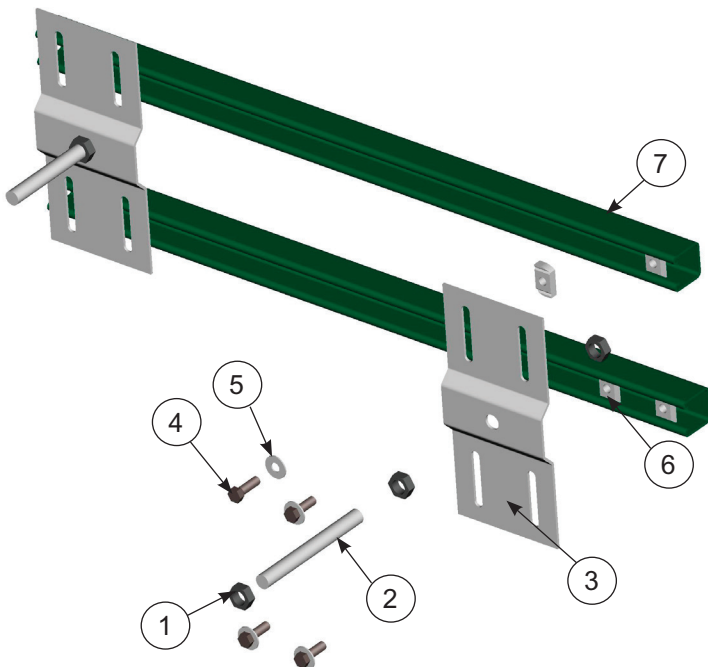
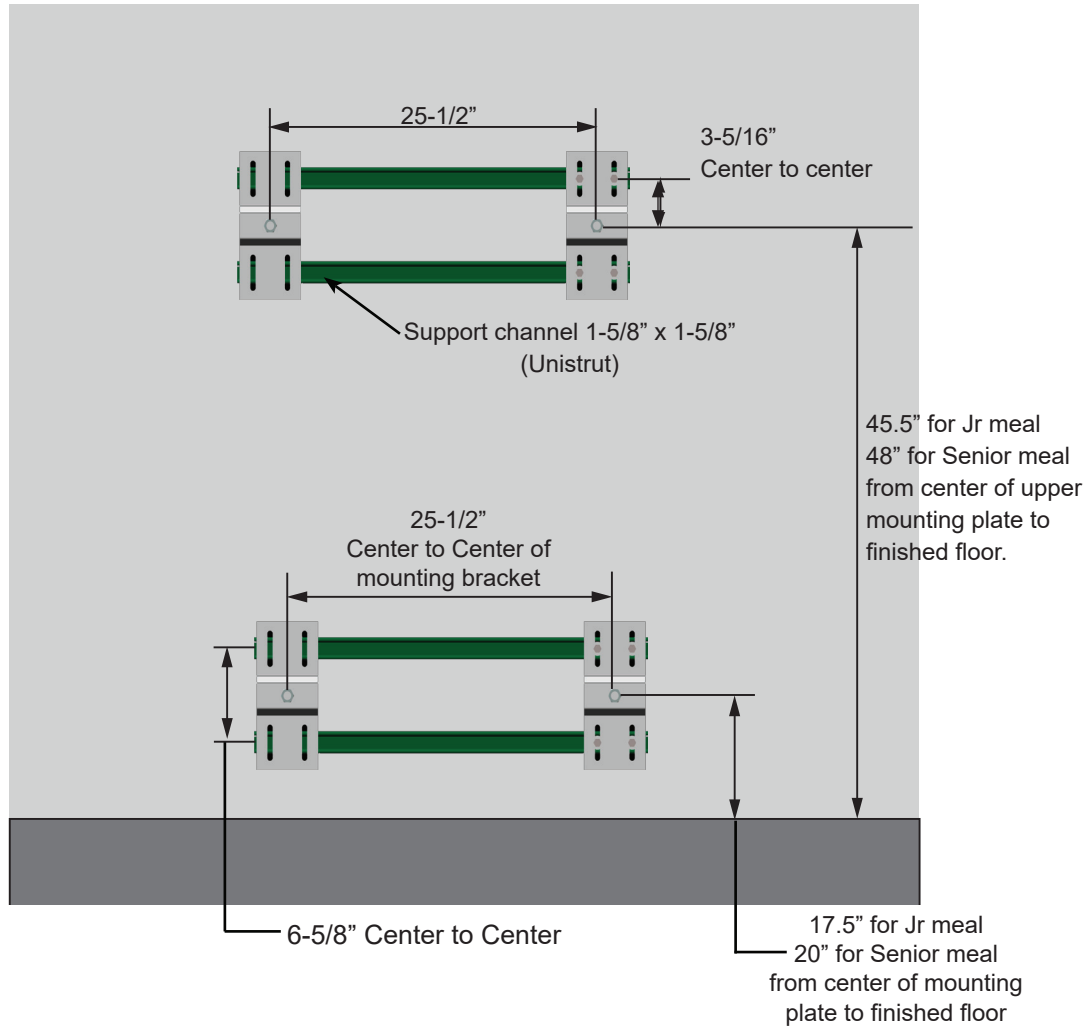

FIGURE 3-2



Wall Mounting Kit Components

#	Description	PN
1	5/8"-11 jam nut	98627
2	5/8"-11x 6" full-thread stud	98626
3	Wall Mounting plate	98672
4	3/8"-16 x 1-1/4" hex head bolt	<a href="#">39618</a>
5	3/8" Belleville washer	97765
6	3/8"-16 channel nut	96332
7*	Unistrut channel	na

\*Item not supplied by ATR

△OPTIONAL WALL MOUNT REQUIRED

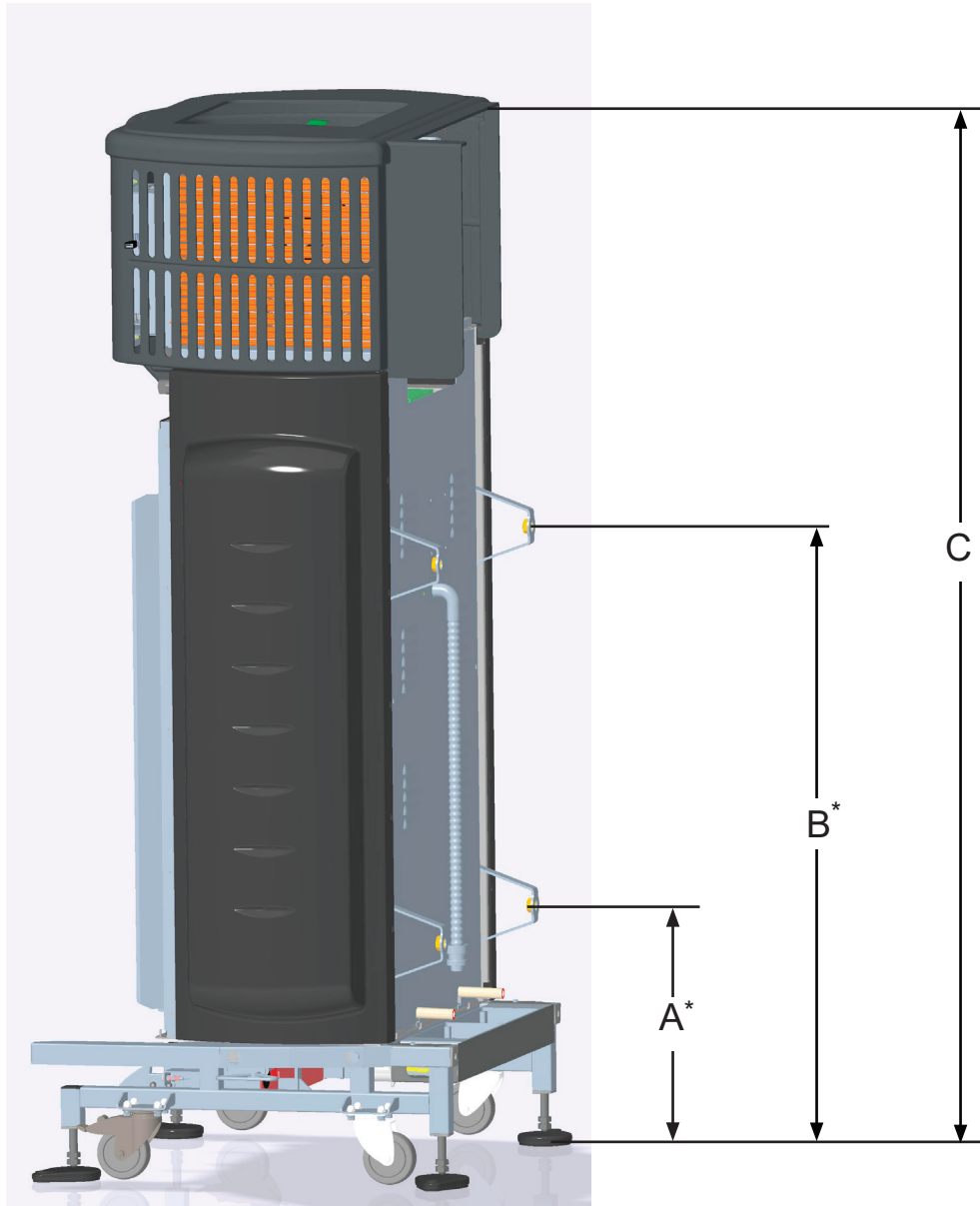

**FIGURE 3-3**

	Mini Unit	Jr Unit	Senior Unit
A	15.6	17.5"	19.75"
B	43.8"	45.5"	47.75"
C	73.5"	77.25"	81.7"

\* From center of mounting plate to finished floor.

## IV. PARTS LIST & ILLUSTRATION

Item	PN	Description
3*	13126	autodock pin
4	96734	blower wheel, cold side (Mini & Jr 3, Sr 1)
5	11991	blower wheel, cold side (Sr qty 2)
6	96887	blower wheel, hot side qty 3
7	96768	brass hook latch, foot pedal
8	13127	bumper (next to magnetic switch)
9	98632	canoe tip (back)
10	98073	cap plastic (top of leveling feet)
11	10840	capacitor motor
12	98086	caster 4" swivel
13	98087	caster 4" swivel with brake
15*	98774	compressor (mini & Jr)
16*	98773	compressor (Sr)
17	13688	condensing unit air cooled (Mini & Jr)
18	13690	condensing unit air cooled (Sr)
19*	99074	condensing unit remote
20*	13912	condensing unit water cooled (Mini & Jr)
21*	13913	condensing unit water cooled (Sr)
22	13104	controller, touchscreen
23	13195	Controller overlay
24*	13152	controller relay board
25*	13511	controller transformer 24v DC
26	13295	controller USB extension cable
27*	13296	controller wiring harness
34*	98681	evap pan bracket
35*	99731	evaporative pan asy
36	96758	filter dryer
37	98838	foot, floor, tear drop
38	10860	gasket, center (mini)
39	98631	gasket, center (Jr)
40	98657	gasket, center (Sr)
41a	11823	heater coil 3100W (mini)
41b	96742	heater coil 2200W (Jr & Sr)

Item	PN	Description
42*	96688	heater gasket, silicone
43	11128	motor, fan cold side and hot side
44*	96156	safe-temp thermocouple (white wire)
45	96787	sensor nut,m14x1,260 brass
46	14203	side panel w insert plastic cold (mini)
47	99789	side panel plastic cold (JR) 49.6"
48	99898	side panel plastic cold (Sr) 54"
49	14272	side panel w insert plastic hot (mini)
50	99790	side panel plastic hot (JR) 49.6"
51	99899	side panel plastic hot (Sr) 54"
52*	96759	site glass
53*	96756	solenoid
54*	98571	solenoid repair kit
55	13130	switch dock/undock
56	11238	switch magnetic
57	13201	switch plate (Jr & Sr)
58	12321	switch plate (Mini)
59	96766	switch, limit, roller plunger, 9ft cable
60	96716	switch, on-off with light knob
61	13356	temperature probe
62	99788	top cover plastic
63	99588	triangle locator
64*	99791	trim strip left & right side (Mini & Jr)
65*	99897	trim strip left & right side (Sr)
66*	96993	valve, thermal expansion hot&cold (Mini & Jr)
67*	97718	valve, thermal expansion cold (Sr)
68*	97719	valve, thermal expansion hot (Sr)
69*	98076	wall mount brackets

\*Item NOT shown

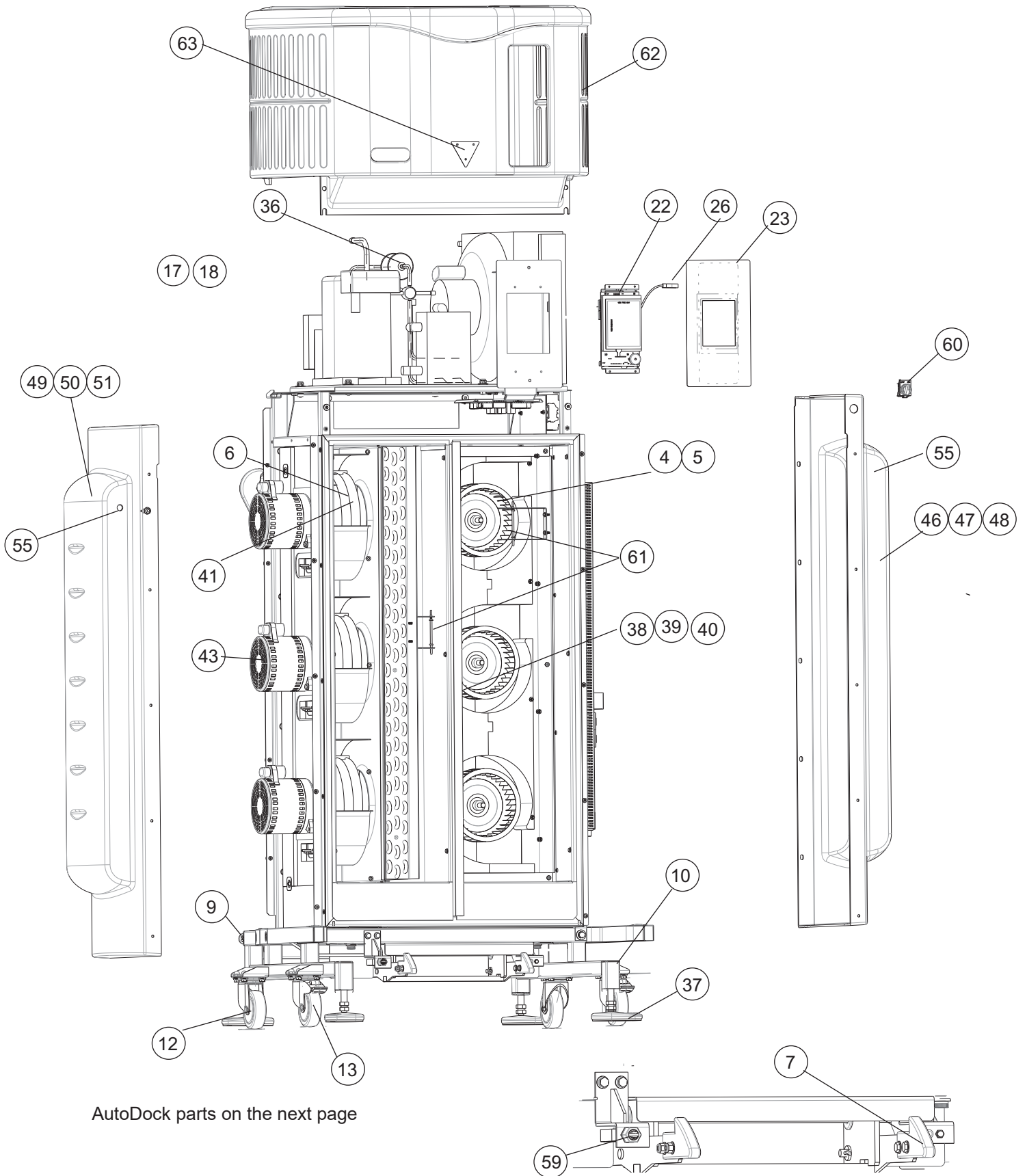

AutoDock parts on the next page

item	PN	description
70	96783	clevis pin, 3/8",5/32" hole,1" lg
71	96784	cotter pin, 5/32" d, 3/4"L
72	96785	thrust bearing,3/8" shft d, 3/4" od,1/8" t
73	13123	linear actuator
74	13126	clevis pin
75	13125	bearing
76	14242*	shim ,3/8" X 0.01"SS (under bearing)
77	13124	shoulder bolt

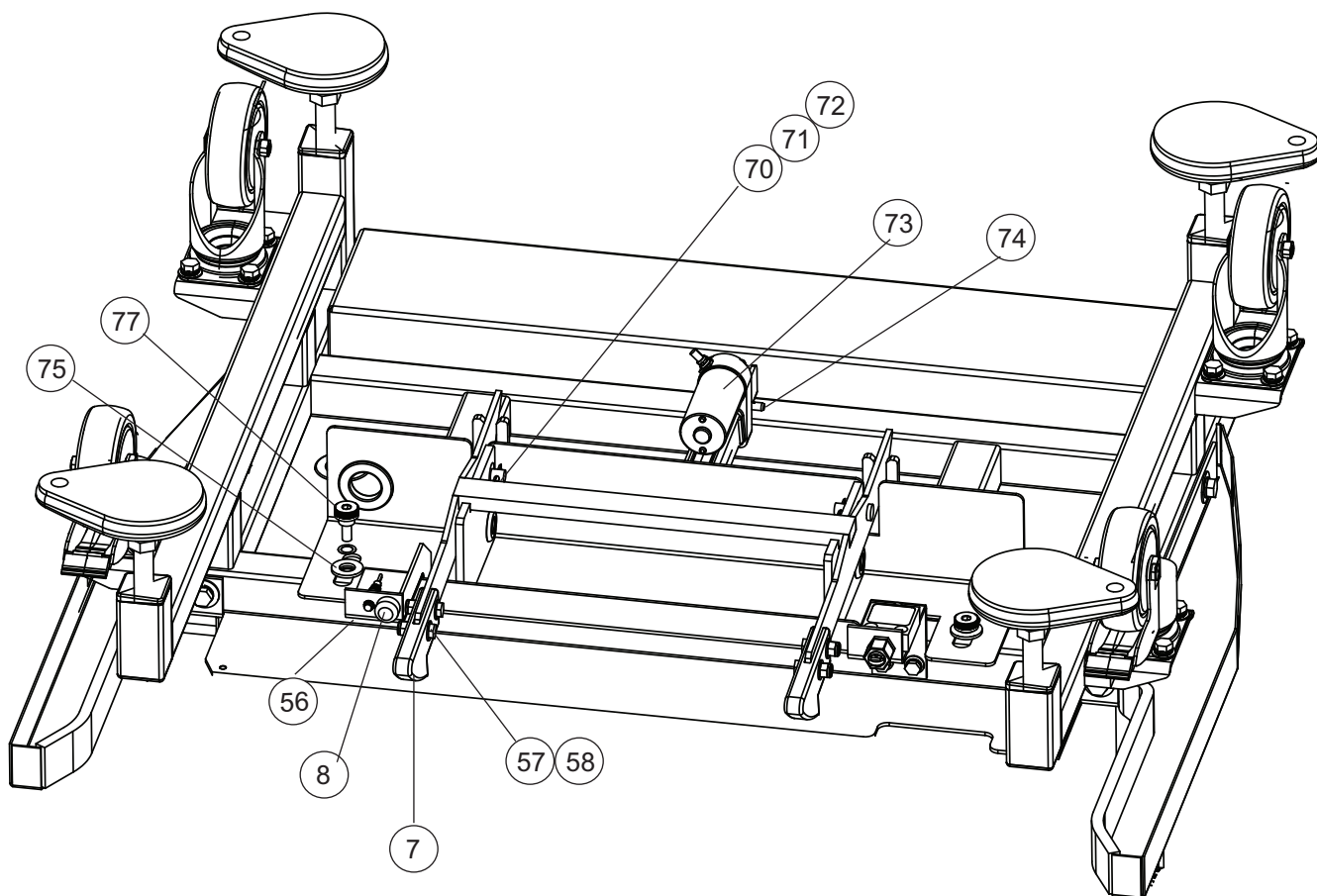

## Paraloop/Remote assembly Illustration

ITEM#	PART	DESCRIPTION
1	99082	1/2" Clamp
2	99086	1/2" Rotolock valve
3	99089	3/8" Breakaway
4	99081	3/8" Clamp
5	99084	7/8" Clamp
6	99087	7/8" Rotolock valve
7	99088	5/8" Breakaway
8	99083	5/8" Clamp
9	99076	Valve pan
10*	99074	Complete assy

\* item NOT shown

**High Side**

**Low Side**

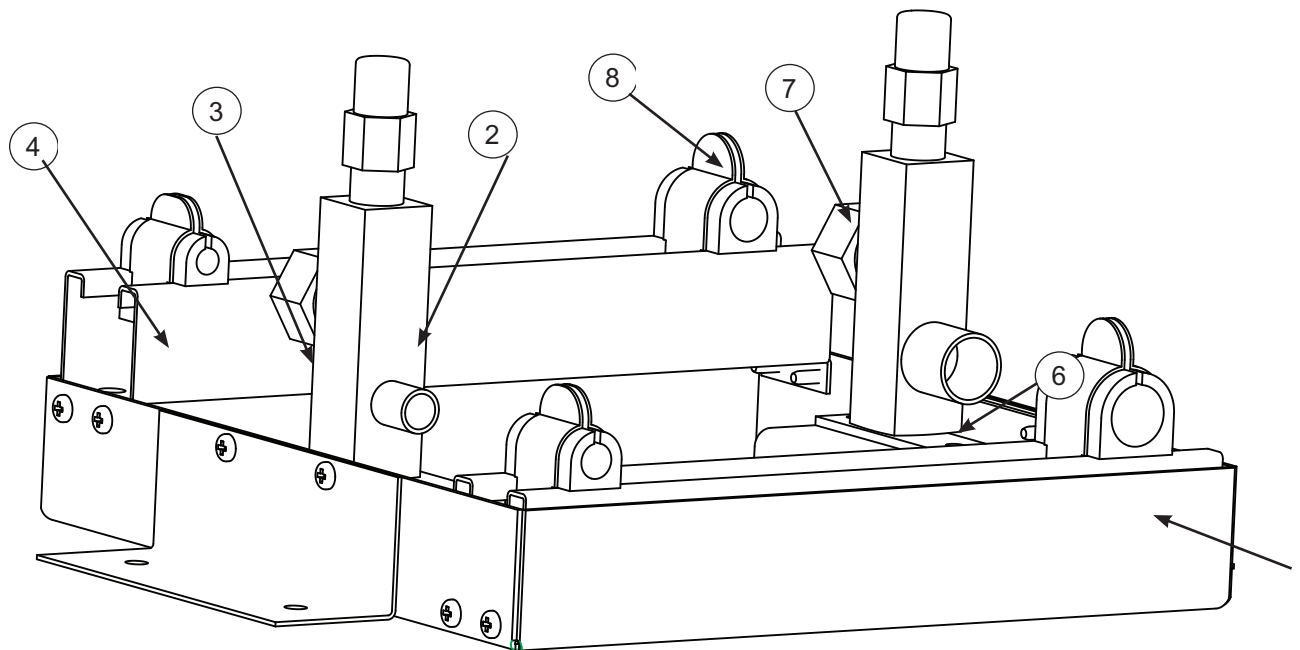

### Electrical Layout and Parts List

### Electrical Parts List

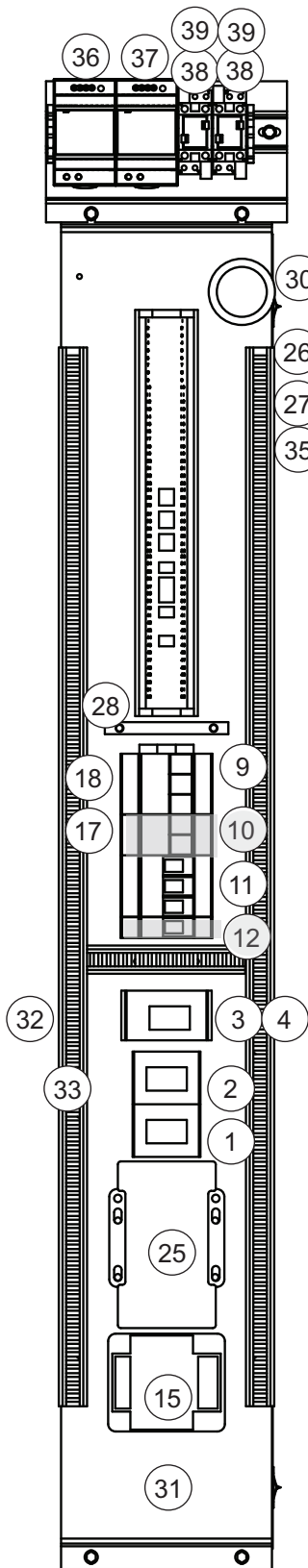

KEY	QTY	SUPPLIER	PART NUMBER	DESCRIPTION
1	1	Aladdin	96910	Contact, IEC 9 Amp, 208 VAC, 4 Pole
2	1	Aladdin	96940	Contact, IEC 9 Amp, 24 VAC, 4 Pole
3	1	Aladdin	96911	Contact, IEC 30 Amp, 208 VAC, 3 Pole
4	1	Aladdin	98231	Auxiliary Contact Block
*5	2	Aladdin	96913	Jumper, 2 Pole
*6	3	Aladdin	96914	Jumper, 3 Pole
*7	6	Aladdin	96915	End Anchor, DIN 35mm
*8	5	Aladdin	96916	End Barrier
9	1	Aladdin	96917	Fuse Block, Class CC, 3 Pole, 600 V, W/Indication
10	1	Aladdin	96918	Fuse Block, Class CC, 2 Pole, 600 V, W/Indication
11	1	Aladdin	96920	Supplementary Protector, 15AMP, 3 Pole
12	1	Aladdin	96919	Supplementary Protector, 4AMP, 1 Pole
*13	30	Aladdin	96921	Terminal, 30 Amp, Gray, 600V, 22-10 Awg
*14	12	Aladdin	96922	Terminal, 30 Amp, Red, 600V, 22-10 Awg
15	1	Aladdin	96923	Transformer, 208V/24V, 63VA
*16	3	Aladdin	96924	Terminal, Grounding, 22-12 Awg
17	2	Aladdin	96925	Fuse, 600V, 4 Amp, Class CC
18	3	Aladdin	96926	Fuse, 600V, 30 Amp, Class CC
*19	1	Allen Bradley	1492-SM6X12	Terminal Strip Marker, Vertical 1-50
*24	9	Thomas & Betts	C10-10	Ring Terminal, Un-insulated, 10-12 Awg, #10
25	1	Aladdin	14230	Contact, 30A, CR2, Allen Bradley
*26	1	Te Connectivity	1-480707-0	Connector 9pin
*27	4	Te Connectivity	1-480709-0	Connector 12 pin
28	1	Square D	PK9GTA	Ground Bar
*29	1	Acco	TS-35	Din Rail, Steel, 7x35mm, (1) 12", (1) 7", (1) 6.5"
30	1	Aladdin	96928	Thermostat, 15A, 250V Contact, 200C Fixed SP
31	1	Quality Ind.	96763	Custom Panel
32	A/R	Thomas & Betts	F1A2LG6	Wire Duct, 1 x 2" Gray
33	A/R	Thomas & Betts	C1LG6	Wire Duct Cover, 1" Gray
35	16	Te Connectivity	350570-7	Connector, crimp socket
36	1	Aladdin	13113	Power supply 24VDC
37	1	Aladdin	13418	Power supply 15VDC NUC
38	2	Aladdin	13115	Socket 24VDC DPDT
39	2	Aladdin	13114	Relay 24VDC DPDT

\* Item not shown

---

---

## Safe-Temp2 Parts (OPTIONAL)

Description	DIGITAL	WIFI
Temperature transmitter (Hot & Cold side)	11161	11154
On/Off switch transmitter	11162	-
Thermocouple (Hot & Cold side)	96156	96156
Address label	98315	98315
Mounting bracket	99923	99923
Wi-Fi 24 volt power supply	-	11849
Wi-Fi dc plug (6' cable)	-	11850
<i>NOTE: DIGITAL transmitters have blue wire terminals</i>		

## ClearLink Parts (OPTIONAL)

Description	WIFI
NUC mini computer	13387
USB to RS485 cable	13294
15 volt power supply	13418
DC plug (6' cable)	13417

---

# V. OPERATION & PROGRAMMING

---

The Convect-Rite 3 Insight System is safe and easy to operate. The system uses the most advanced rethermalization methods available. Please refer to the Owner's Manual, Operating & Programming sections for details on how to operate the Convect-Rite 3 Insight System.

# VI. PREVENTIVE MAINTENANCE

## PREVENTIVE MAINTENANCE AND CLEANING

### INTRODUCTION

Maintenance on the Convect-Rite 3 Insight Docking Station must be performed on a regular basis to keep the unit operating properly. Follow the maintenance instructions in this chapter and problems will be kept to a minimum. If problems do occur, refer to the Troubleshooting Guide.

 <b>WARNING</b> 
<b>DEATH, INJURY, OR EQUIPMENT DAMAGE</b> may result from improper service or maintenance practices. Always turn the main power switch or breaker on the Docking Station switch to the OFF position on each unit before starting service, maintenance, or repairs.

### Convect-Rite 3 Insight Docking Station

#### Daily

- Clean the exterior of the unit only. As with any other piece of equipment containing electrical components, it should be cleaned on a regular basis with a wet sponge. Wipe it dry with a smooth cotton cloth. Avoid the use of abrasive products or chlorides. Do not spray Docking Station with **hose or steam wand**.

#### Monthly

- Check and adjust the Docking Station micro limit switches as required.
  - Check and tighten all adjustment bolts both at the wall and on the floor.
- Check alignment of each dock for proper docking. Adjust as needed.

#### Biannually

- Verify proper operation of timer: reset clock time if needed.
- Check for proper voltage supply to the rethermalization unit. Refer to the data plate for the proper voltage supply.
- Check electrical cord and connections for broken or loose wires.
- Remove side covers and check all electrical connections tighten as needed.

- 
- 
- Verify that the temperature on the docking station is chilling down.
  - Check heaters for operation. Replace or repair as needed.
  - Fans are located across the front of the unit. Check shaft bearings & motor couplings replace as needed. Viewing from inside, verify all circulating fans are operating properly and are unrestricted.
  - Check that evaporator pan is heated. Check connections and/or replace if pan not warm.  
Replace pan if water leaking or pan is severely pitted.
  - Check for proper refrigerant pressure levels (as required on data plate) as needed. Physically check for refrigerant leaks at the compressor, evaporator coils and associated piping. Charge as needed
  - Remove the black plastic top cover of the Docking Station. Vacuum the condensing unit coil to remove dust and dirt.

## CAUTION

Inside and outside front panel of the hot section of the Convect-Rite 3 Insight Docking Station stays hot for a short period of time after rethermalization. Allow 15 minutes for cool-down before cleaning.



### **Cleaning of plastic top and side panels:**

**NOTE:** It is extremely important to read the following instructions for cleaning plastic ancillary equipment.

---

- It is sufficient to wipe the plastic components of the Convect-Rite 3 Insight Docking Station with a soft cloth using warm water (Not to Exceed 140°F/60°C) to which diluted detergent has been added . The detergent used must have a low alkaline value and contain a very low percentage of caustic soda. The detergent must not exceed the dilution rate recommended by the supplier.
- After cleaning these components, wipe down with a soft cloth using clear water.
- Make sure that all plastic components are thoroughly dried before using.
- Manufacturer accepts no responsibility if the above instructions are not strictly adhered to.

**OPERATOR'S TROUBLESHOOTING GUIDE FOR OPERATIONAL SAFETY**

 <b>WARNING</b> 
<p><b>DEATH, INJURY, OR SHOCK</b> can occur by touching electrical components and wires inside the Docking Station when the main power switch is in the ON position.</p>
<p><b>NEVER REMOVE THE PLASTIC TOP OR SERVICE ACCESS PANELS</b> of the Docking Station while main power switch is in the ON position. Allow only authorized factory trained service representatives to perform service, maintenance and repairs that require the removal of the plastic top or service access panels.</p>

This troubleshooting guide includes a list of conditions that may be encountered during routine operation and maintenance. The first column on the left on the following page describes these symptoms. The second column in the middle lists the causes for the conditions listed in column one. The third column on the right lists remedies and/or references for the conditions and causes in columns one and two.

**DO NOT TRY** to correct the condition that requires an authorized service representative as this may adversely affect the warranty coverage.

**TROUBLESHOOTING NOTES**

1. If problem is inside the Docking Station, call the Aladdin Temp-Rite® Service Department at 1-800-888-5426. Aladdin will not pay for warranty repairs by unauthorized repair centers.
2. Repairs to external wiring should be done by a Licensed Electrician.
3. Proper installation of the Convect-Rite 3 Insight Docking Station is the responsibility of the owner or installer.
4. Repairs to external plumbing (if required) should be done by a Licensed mechanical contractor.
5. Repairs to compressor-condensing unit should be done by a Licensed Refrigeration Engineer.

<b>Condition is occurring when:</b>	<b>Condition/symptom:</b>	<b>Solutions and things to check:</b>
<i>Moving the Docking Station</i>	Leveling feet hit thresholds and other floor imperfections.	Raise feet to full up positions.
		Use ramp to roll dock over obstruction
	Casters do not roll	Check that lock is not depressed on either front caster.
<i>Installing the Docking Station.</i>	Leveling feet will not lower or raise.	Unlock 5/8" jam nut
		Adjust feet by turning 5/8" nut
		Check that black tube caps are not in the tube.
	Leveling feet will not reach wall due to wall imperfections.	Securely fasten a 2"X8"X4' wood board to the wall to close gap between leveling feet and wall.
<i>Engaging the cart to the Docking Station.</i>	Gap exists between cart and dock when cart is engaged.	Adjust appropriate feet to close gap
	Cart does not depress one or both switches	Check that the dock is parallel to cart interface.
		Make sure cart has a magnet
		Check for damaged sensor
		Adjust contact switch bracket
	Docking Station rolls or creeps in location over time.	Check that dock is not resting on casters.
		Use floor to secure front leveling feet.
		Check that leveling feet have rubber grips.
	Cart doesn't engage	Check that dockside door is open
		Check that dock is secured properly against the wall
		Check that dock is parallel to cart
		Check that the optional safety doors on the Docking Station are not closed
		Check that the side of the cart with the locking casters is facing away from the dock
		Check that the dock is at the appropriate height for the cart
		Check that the dock has power
Cart pulled in, but is immediately released	adjust contact switch in or out	
	level docking station	
	check docking height	
	Check micro switch position (see section III for location)	
	Controller shows Cart no present	

Condition is occurring when:	Condition/symptom:	Solutions and things to check:
		Check "on/off" switch
		Check safety switches
		Check unit breaker in control panel
		Check all wiring is properly seated
		Check plug or junction box
<i>Loading trays</i>	Tray does not slide in slot	Check that the tray is not warped or damaged
		Auto-therm seal may be jammed
<i>Shutting doors</i>	Doors on cart won't close	Tray not completely pushed in
		Check latch and door alignment
		Check gasket fit
<i>Keeping cart door open</i>	Door not engaged in detent latch	Push door completely to the side of the cart (270°)
		Check that door at hinge is completely seated
		Check that no debris is around detent latch
<i>Chill Down</i>	Cart engaged--compressor hums, but does not start up	Contact ATR technical service representative
	Cart engaged--compressor does not hum and does not start up	Contact ATR technical service representative
	Cart engaged but evaporator fans do not turn on	Contact ATR technical service representative
	Unit does not chill down (reach programmed settings) in one hour	Check that cart doors are completely closed
		Make sure doors are adjusted to prevent air leak around doors
		Check that there is no air leak between dock and cart
		Initial temperature of food may be too high
		Make sure ambient air temperature is less than 85 degrees F.
		(Remote ONLY) check that service valve is not closed.
		(Water cooled ONLY) check that water self-regulating valve has not been closed.
		(Water cooled ONLY) Check that water self-regulating valve has been set to 250 psi head pressure.
	Compressor does not cycle off in one hour	Check that cart doors are completely closed

<b>Condition is occurring when:</b>	<b>Condition/symptom:</b>	<b>Solutions and things to check:</b>
		Make sure doors are adjusted to prevent air leak around doors
		Check that there is no air leak between dock and cart
		Check condenser for proper spacing and air ventilation, and coil free of debris
<i>Cold holding overnight</i>	A significant amount of water appears on floor the following morning	Check that water in evaporator drain tubes drains into condensate pans
		Check the connection between the condensate evaporating pans to insure it is not clogged.
		Check for air leaks between cart and dock
		Check that evap pans are getting hot.
		Check for air leaks around cart doors
	Evaporator has frost exceeding 10% of coil	Defrost occurrence and duration is not often or long enough. Adjust as necessary to eliminate condition.
		Check for air leaks between cart and dock
		Check for air leaks around cart doors
<i>Heating Cycle</i>	Does not start Heating cycle	Check that automatic programmed start time window has not passed
		Check that controller is in automatic or manual Heating mode
		Check time AM-PM
	Heating cycle is too long/short	Check meal setting in program
		Check time of meal settings
		Wrong meal may have been selected in manual mode
		Cart was disengaged too soon or during cycle
	Unit does not reach Heating temperature setting at end of cycle and hot food temperature is NOT acceptable	Slots in cart center panel may be missing auto-therm seals or stuck in the "up" position.
		Check that all fans are turning
		One or more heater elements may not be functioning.
		Check for air leaks between cart and dock
		Check for air leaks around cart doors

Condition is occurring when:	Condition/symptom:	Solutions and things to check:
	Heater element(s) do not get hot	Check components (Electrical Contractor)
<i>Equalization Cycle</i>	Does not start Equalization	Check that Equalization time is programmed
	Equalization cycle is too long/short	Adjust Equalization cycle temperature setting(s) and duration(s)
<i>Hold Cycle after Equalization</i>	Does not start Hold	Check that Hold time is programmed
	Hold cycle is too long/short	Adjust Hold cycle temperature setting(s) and duration(s)
<i>Disengaging cart</i>	Cart will not disengage	Push and Hold undock button Check for power to unit. Check that mating mechanism has released the cart if not emergency release may have to be used
		Check cart caster locks
		Use the 9 volt emergency release on the right side of the dock.
	Dock continues to run when cart is disengaged	Check that micro switch is not sticking closed
<i>Hot food temperatures</i>	Hot food temperatures not hot enough after Heating and equalization	Check Heating/Equalization cycle temperature setting(s) and duration(s)
		Check for air leaks between cart and dock
		Check for air leaks around cart doors
		Slots in cart center panel may be missing auto-therm seals or stuck in the "up" position.
		Inappropriate entrée dome, mug & soup bowl may be in use
		Check that all fans are turning
		One or more heater elements may not be functioning.
		Wrong meal may have been selected in Manual mode
		Adjust temperature setting and tolerance
	Hot food temperatures too hot after Heating and Equalization	Wrong meal may have been selected in Manual mode
		Inappropriate entrée dome, mug & soup bowl may be in use
		Adjust Heating/Equalization cycle temperature setting(s) and duration(s)
		Food input temperature may have been too high.

<b>Condition is occurring when:</b>	<b>Condition/symptom:</b>	<b>Solutions and things to check:</b>
	Hot food temperatures have more than 20°F difference from tray to tray	Slots in cart center panel may be missing auto-therm seals are stuck in the “up” position. Push all seals down. Clean debris if present.
		Check that all fans are turning
		Check for presence of air deflectors inside the supply plenum on the cart
		One or more heater elements may not be functioning.
<i>Cold food temperatures</i>	Cold food temperatures not cold enough after one hour of chill down cycle	Check for air leaks between cart and dock
		Check for air leaks around cart doors
		Check that all fans are turning
		Check to see if compressor is running
		Check to see if system is generating cold air (possible refrigerant leak)
		Adjust temperature setting and tolerance
	Cold food temperatures have more than 5°F difference from tray to tray	Check that all fans are turning
		Check for presence of air deflectors inside the supply plenum on the cart
		Slots in cart center panel may be missing auto-therm seals or stuck in the “up” position. Clean debris if present
<i>Controller Display</i>	Improper temperature units	Check program for proper unit - °C or °F

## SERVICING PROCEDURES

### FOR SERVICE ACCESS:

Adjust the four feet on the base of the Docking Station, lower the unit onto the casters. Remove floor brackets. Pull unit away from the wall and turn 90°-180° for ease of access.

### MOTOR, HOT SIDE

1. See “FOR SERVICE ACCESS” then remove the fasteners:
  - a. That hold the rear surface of the side panel to the Upper Dock Frame
  - b. That holds the left trim piece to the Upper Dock Frame (i.e., leave the trim angle attached to the side panel)
2. Disconnect wiring for the failed motor. (Time-saving tip: splice the wiring of the new motor into existing wiring) \*\*Confirm that the problem is NOT the motor’s capacitor before removing the motor, as a capacitor is a much easier replacement\*\*
3. Remove the front assembly from the front of the unit by removing the top two fasteners before lifting the frame to clear the bottom pins. Mark or measure the placement of the blower wheel on the shaft and its depth from the side wall. (See Step 7)
4. Loosen the blower wheel set screw that keeps the wheel mounted to the shaft of the failed motor so that blower wheel will slide off the shaft when you remove the motor. (You may remove the front portion of the scroll to give you additional room should you feel you need it.)
5. Remove the 1/4” fasteners holding the motor to the motor mount panel before removing the motor from the panel. It may take some work to remove the fan from the shaft though the set screw has been loosened.
6. Replace the failed motor and attach the new motor in the same position and in the same orientation (capacitor at 12 o’clock). Use the same 1/4” fasteners to secure the motor.
7. Attach the fan blower wheel to the shaft of the motor and slide the wheel down to the same depth from the wall that you measured in step 3. Tighten the setscrew on the FLAT portion of the shaft.
8. Reattach all removed components.

---

---

## MOTOR, COLD SIDE

1. See "FOR SERVICE ACCESS" then slide the unit forward across the floor and remove the fasteners:
  - a. That hold the rear surface of the side panel to the Upper Dock Frame
  - b. That holds the right trim piece to the Upper Dock Frame (i.e., leave the trim angle attached to the side panel)
  - c. That hold the rear panel in place.
2. Disconnect wiring for the failed motor. (Time-saving tip: splice the wiring of the new motor into existing wiring) \*\*Confirm that the problem is NOT the motor's capacitor before removing the motor, as a capacitor is a much easier replacement\*\*
3. Remove the control panel, housing insulation, housing access panel and EPS vane.
4. Mark or measure the placement of the blower wheel on the shaft and its depth from the side wall. (See Step 8)
5. Loosen the blower wheel set screw that keeps the wheel mounted to the shaft of the failed motor so that blower wheel will slide off the shaft when you remove the motor.
6. Remove the 1/4" fasteners holding the motor to the motor mount panel before removing the motor from the panel. It may take some work to remove the fan from the shaft though the set screw has been loosened.
7. Replace the failed motor and attach the new motor in the same position and in the same orientation (capacitor at 12 o'clock). Use the same 1/4" fasteners to secure the motor.
8. Attach the fan blower wheel to the shaft of the motor and slide the wheel down to the same depth from the wall that you measured in step 4. Tighten the setscrew on the FLAT portion of the shaft.
9. Reattach all removed components

## HEATERS

1. See "FOR SERVICE ACCESS" then remove the fasteners:
  - a. That hold the rear surface of the side panel to the Upper Dock Frame
  - b. That holds the left trim piece to the Upper Dock Frame (i.e., leave the trim angle attached to the side panel)
2. Disconnect the wiring for the failed heater.

3. Remove the perforated plates from the front of the unit and then remove the orifice plate. Mark the location of the blower on the shaft.
4. Remove front part of the shroud, and then loosen the blower wheel mounted to the shaft of the motor so you can easily slide it off.
5. Replace the failed heater and rectangular silicone insulator. Be careful to attach the wires to the same terminal locations.
6. Attach the fan blower wheel to the shaft of the motor and slide down so it is set at a depth on the shaft marked previously. Tighten setscrew on the “**FLATS**” of the shaft.
7. Reattach all removed components.

#### GASKET

1. Remove damaged gasket.
2. Obtain a new gasket and **install the corners or ends first**, and then continue towards the center, spreading gasket uniformly so no wrinkling occurs.

#### LIMIT SWITCH

1. See “FOR SERVICE ACCESS” then remove the fasteners:
  - a. That hold the rear surface of the side panel to the Upper Dock Frame
  - b. That holds the left trim piece to the Upper Dock Frame (i.e., leave the trim angle attached to the side panel)
2. Disconnect the limit switch wiring.
3. Remove protective brass nut from the front of failed limit switch.
4. Remove thin nut and pull failed switch out.
5. Obtain new limit switch and install it onto the base bracket. Locate and secure the switch with thin nuts that come with the switch and tighten down completely with protective brass nut. Make sure that new limit switch extends to the same level as existing one.
6. Connect wiring and reattach all removed components
7. Dock cart to check engagement. Adjust the limit switch accordingly.

---

---

## MAGNETIC SENSOR SWITCH

1. Remove the front plastic nut.
2. Pull sensor out from the rear of the bracket, cut wire leads and attach new sensor.
3. Insert new sensor into hole in bracket and attach front plastic nut. \*front of sensor must be flush with the face of the front nut.\*
4. Tighten the rear nut.
5. Test Function

## LINEAR ACTUATOR

1. Pull out the front clevis pin holding the cylinder (attached to the emergency release handle).
2. Pull out the rear clevis pin.
3. Cut wire leads (note color of wires for reattachment), then attach new linear actuator wire leads. (See wiring diagram if needed)
4. Insert rear clevis pin first. Rest front cylinder end on floor.
5. Cylinder will need to be extended prior to attachment. To extend the cylinder you will need to access the diagnostic menu on the controller.
6. Press “Settings” gear icon. Enter passcode.
7. Press “Diagnostic”
8. Press “Cart Release” until cylinder extends enough to attach from clevis pin.
9. Align holes and insert front clevis pin (with emergency handle) .
10. Test Function

### EVAPORATIVE PAN

1. See “FOR SERVICE ACCESS” then slide the unit forward across the floor and remove the fasteners:
  - a. That hold the rear surface of the side panel to the Upper Dock Frame
  - b. That holds the right trim piece to the Upper Dock Frame (i.e., leave the trim angle attached to the side panel)
  - c. That hold the read panel in place
2. Disconnect failed evaporative pan wiring.
3. Replace the pans and install new pans, making sure that drain piping goes inside the pans. Recommend cleaning drain piping at the same time.
4. Connect wiring and reattach removed components.

## **REPAIRING THE REFRIGERATION SYSTEM**

### **PUMP DOWN**

1. Close the receiver outlet valve and operate the compressor until the suction pressure gauge levels off to 3-5 psi.
2. Close the receiver valve and stop the compressor.
3. The system can now be opened for repair.

### **LEAK CHECKING**

1. Once a repair has been made, pressurize and leak test the entire system including the condensing unit, evaporator, and all connecting tubing, fittings, and brazed joints using the intended operating refrigerant for leak testing.
- 2. DO NOT USE OXYGEN OR COMBUSTIBLE GASES FOR LEAK TESTING.**
3. A pressure equal to the low side test pressure marked on the unit nameplate is recommended for leak testing.
4. Again, repair any leaks found.

---

---

## EVACUATION

1. Connect a vacuum pump to both the low and high side evacuation valves with copper tube or high vacuum tube (3/8" ID MIN.) and draw a deep vacuum of at least 1500 microns.
- 2. DO NOT USE THE MOTOR-COMPRESSOR TO PULL A VACUUM.**
- 3. DO NOT OPERATE THE MOTOR-COMPRESSOR IN A VACUUM.**
4. Break the vacuum with nitrogen.
5. Evacuate the system to hold at 500 microns and break the vacuum with refrigerant.
6. Remove the vacuum pump.
7. The system is now ready for charging.

## CHARGING

1. Charge the system with the correct amount of refrigerant as listed on the data nameplate on the right hand side of the unit.
- 2. DO NOT CHARGE THE UNIT BY THE SITE GLASS LOCATED ON THE CONDENSING UNIT.**
- 3. BE SURE NOT TO OVERCHARGE THE UNIT. AN OVERCHARGE MIGHT PERMIT LIQUID REFRIGERANT TO ENTER THE MOTOR-COMPRESSOR AND DAMAGE THE VALVES, RODS, PISTONS, ETC.**
4. Make sure all flare caps and valve caps are tight.

MINI WIRING DIAGRAMS

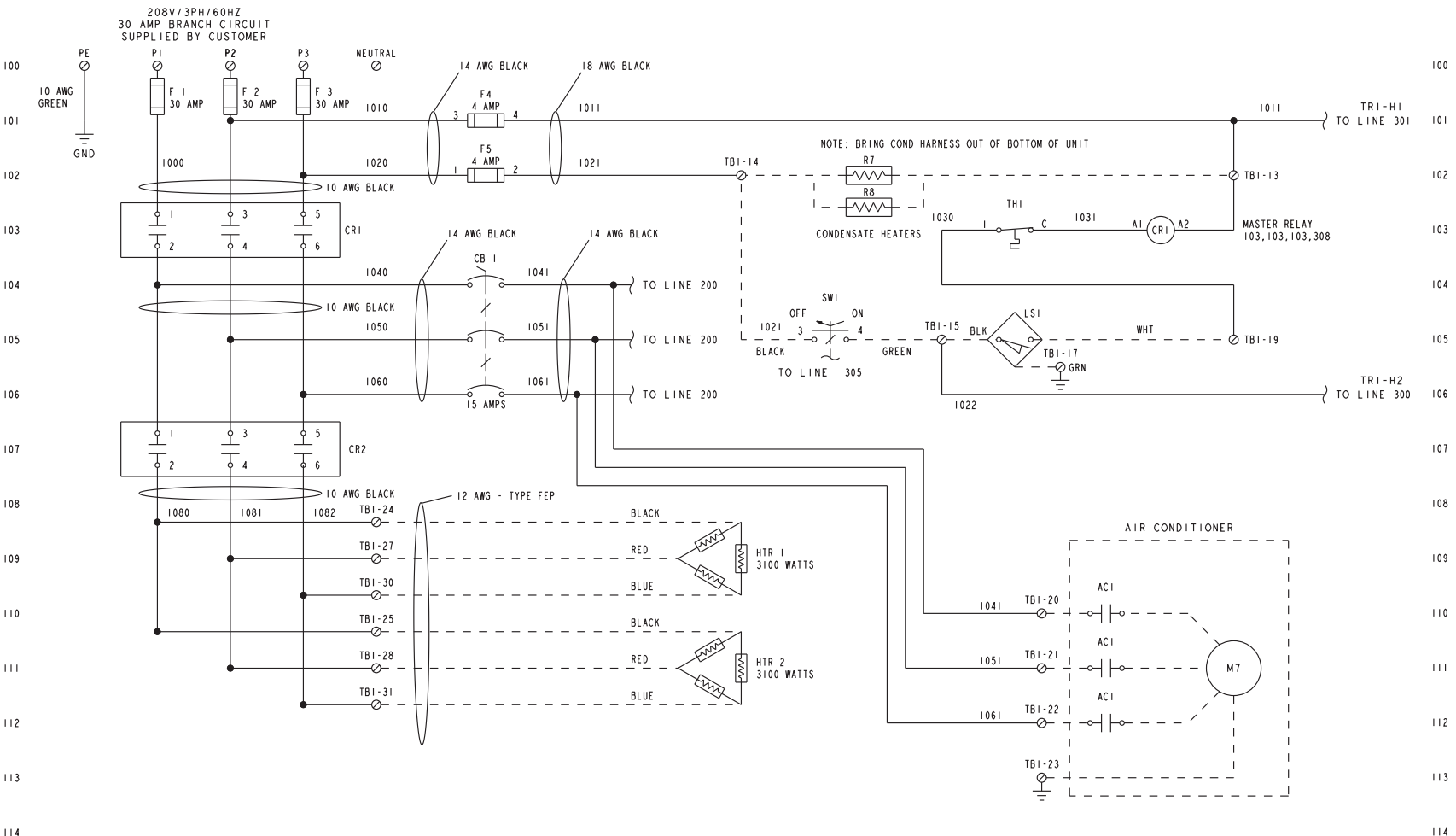

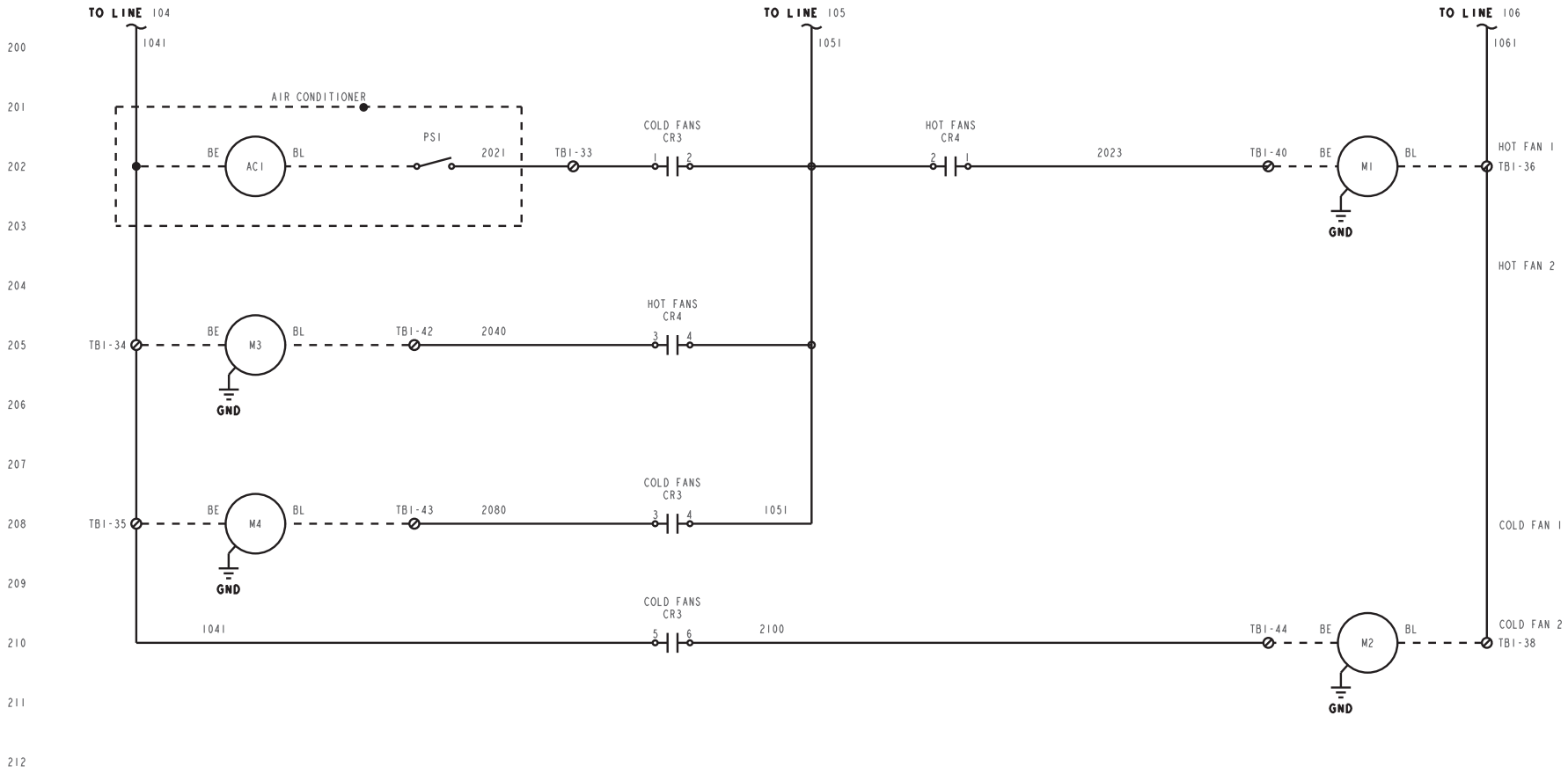

### Mini Wiring Diagram Continued

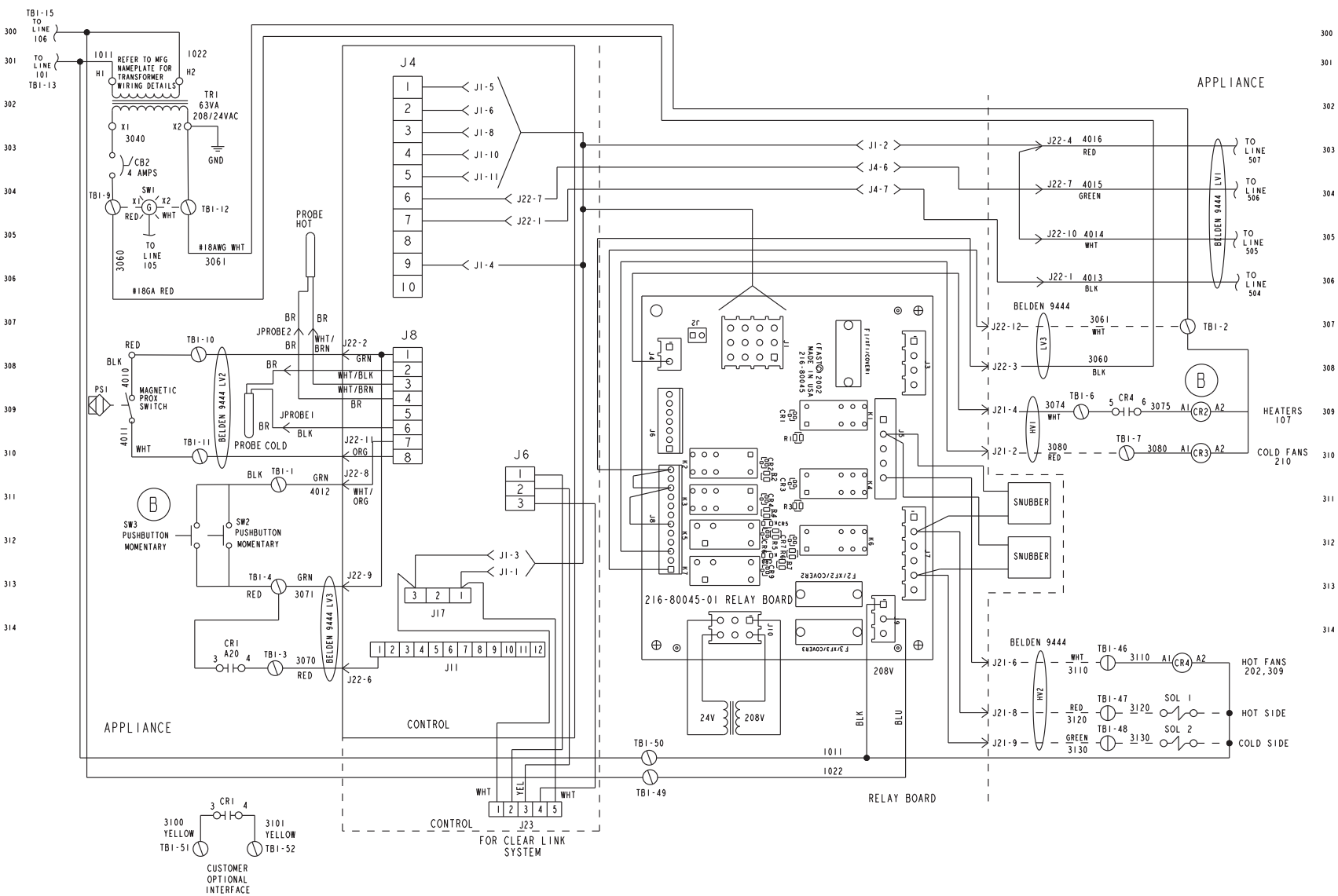

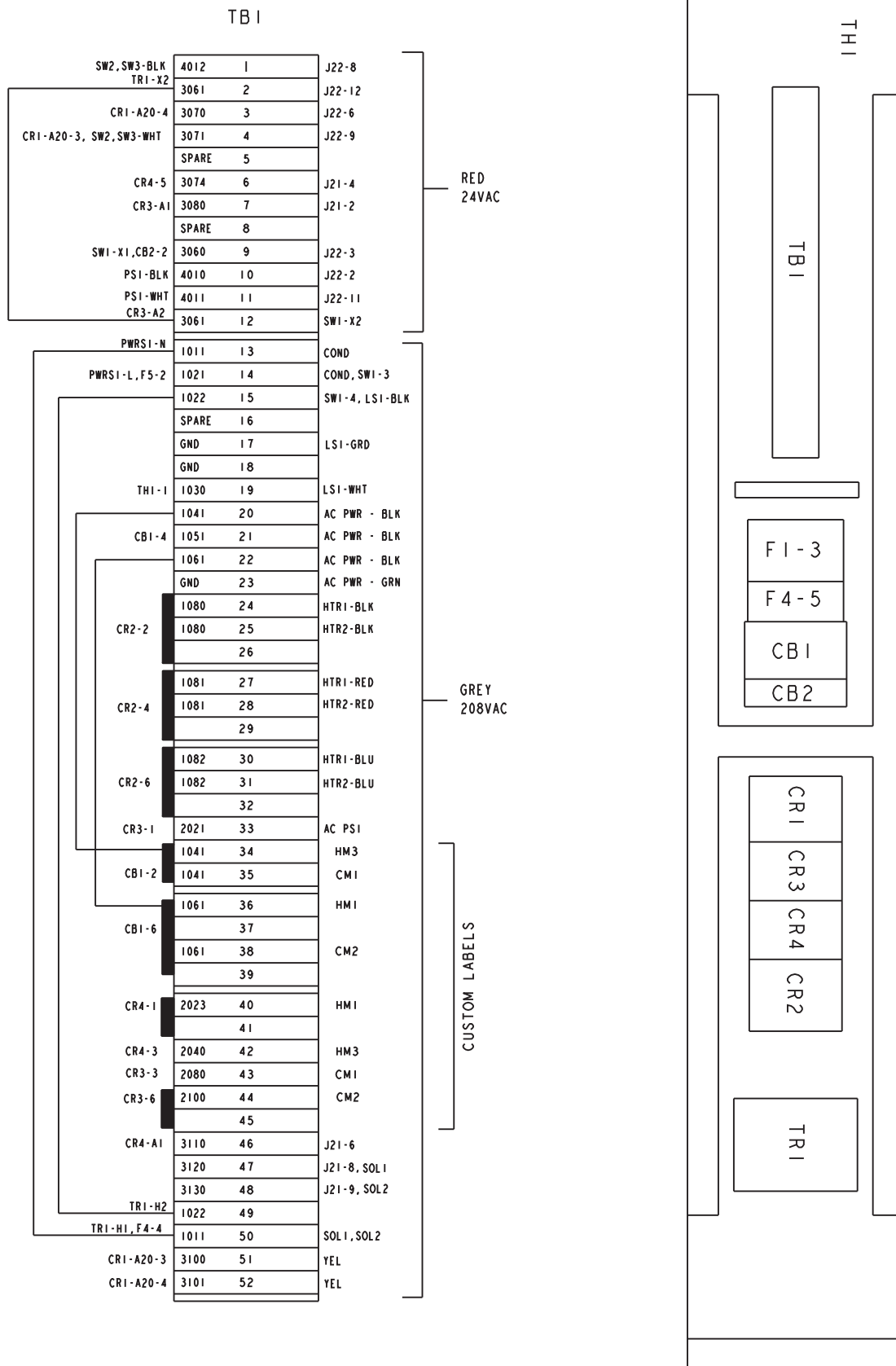

### Mini Wiring Diagram Continued

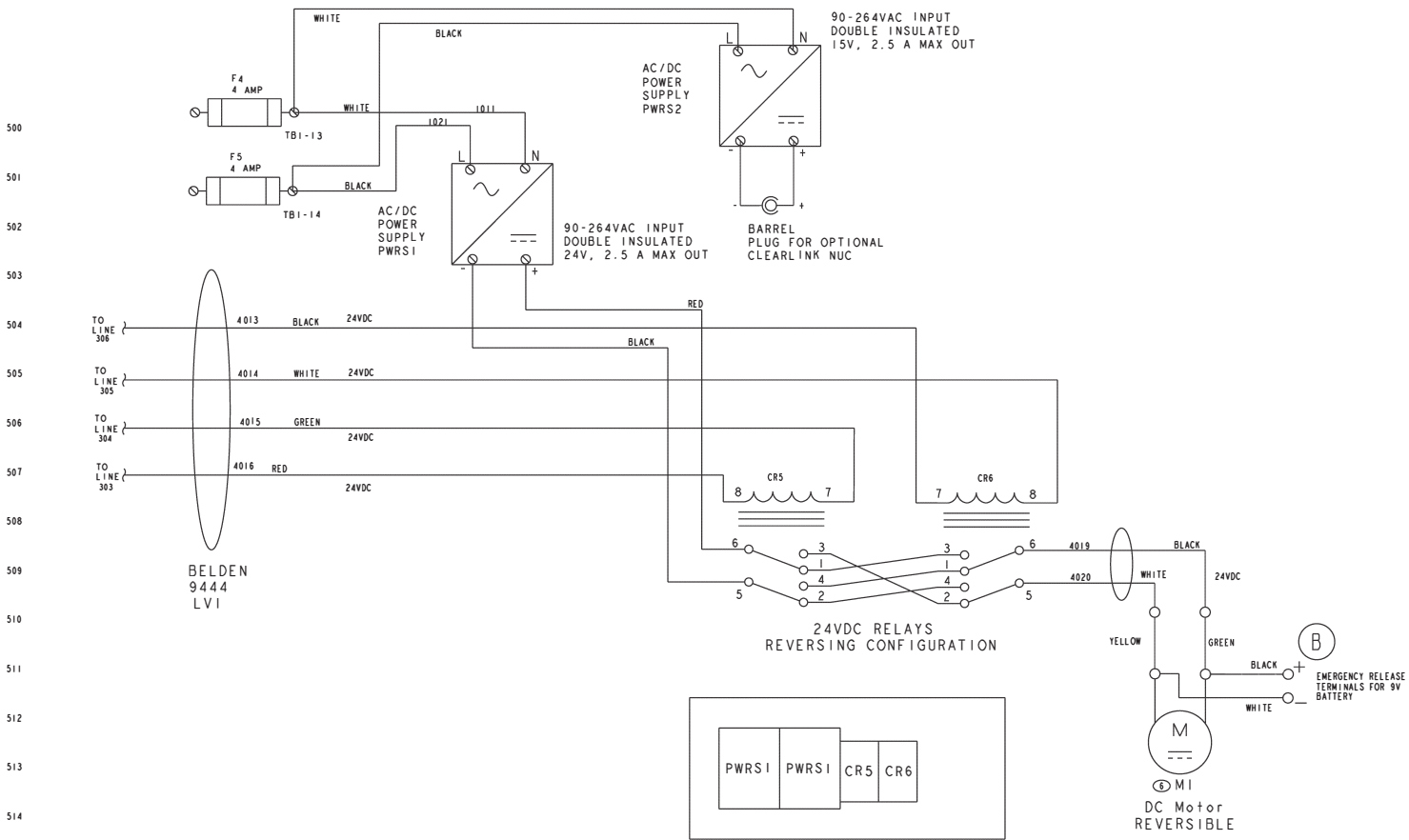

SEE PANEL DRAWING 13226 FOR PANEL DETAILS

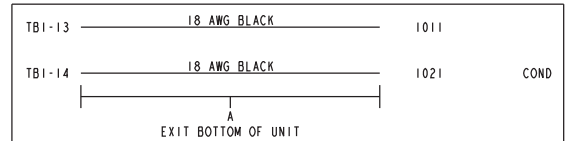
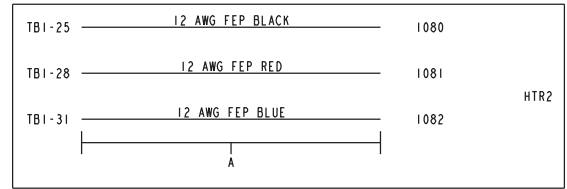
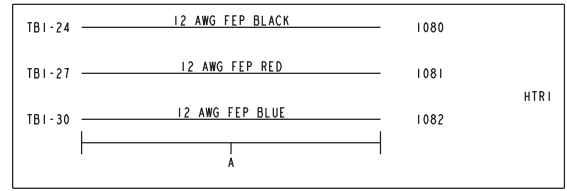
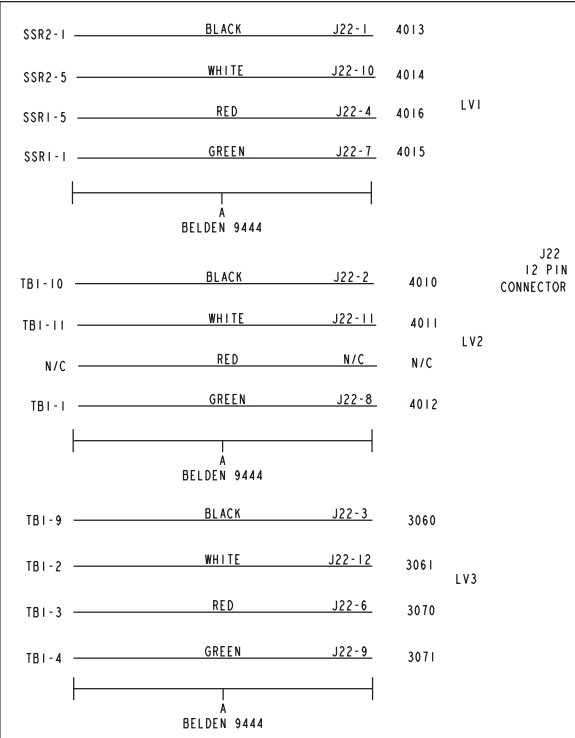
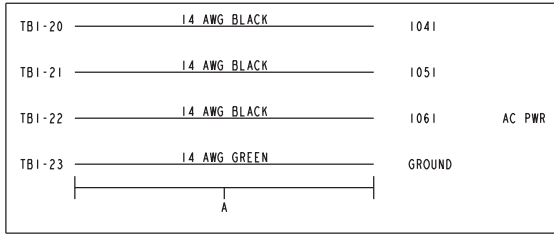
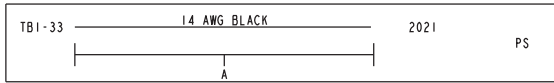
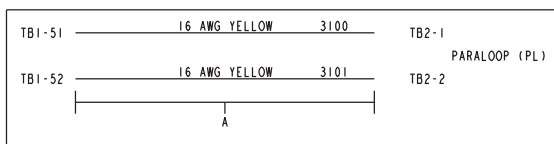
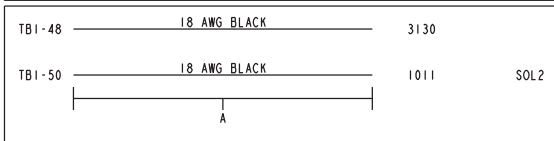
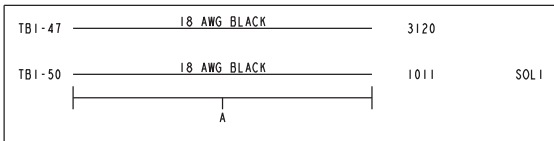
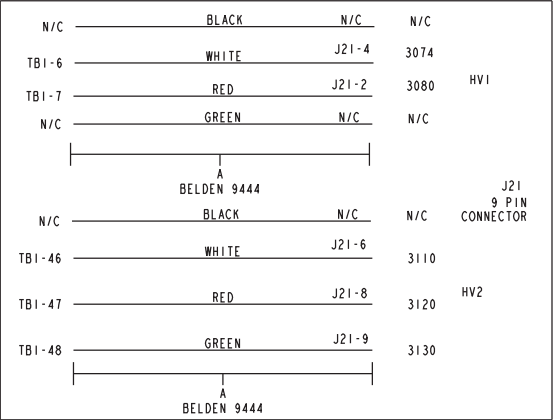
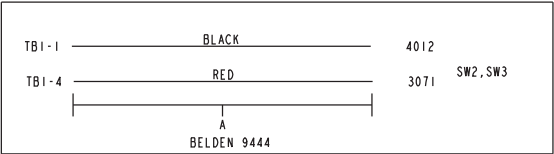
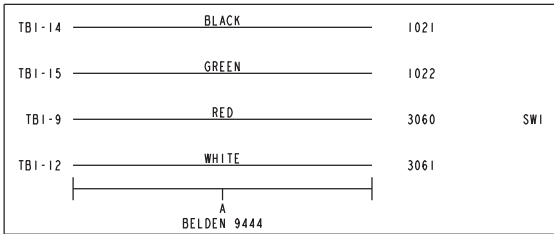

CABLE		LENGTH
SW1, SW2, SW3		7'
PS		7'
AC PWR		7'
J21 9PIN CONNECTOR	HV1	7'
	HV2	7'
J22 12PIN CONNECTOR	LV1	7'
	LV2	7'
	LV3	7'
COND		7'
HTR1		7'
HTR2		7'
SV1		7'
SV2		7'
PARALOOP (PL)		7'

JUNIOR & SENIOR WIRING DIAGRAM

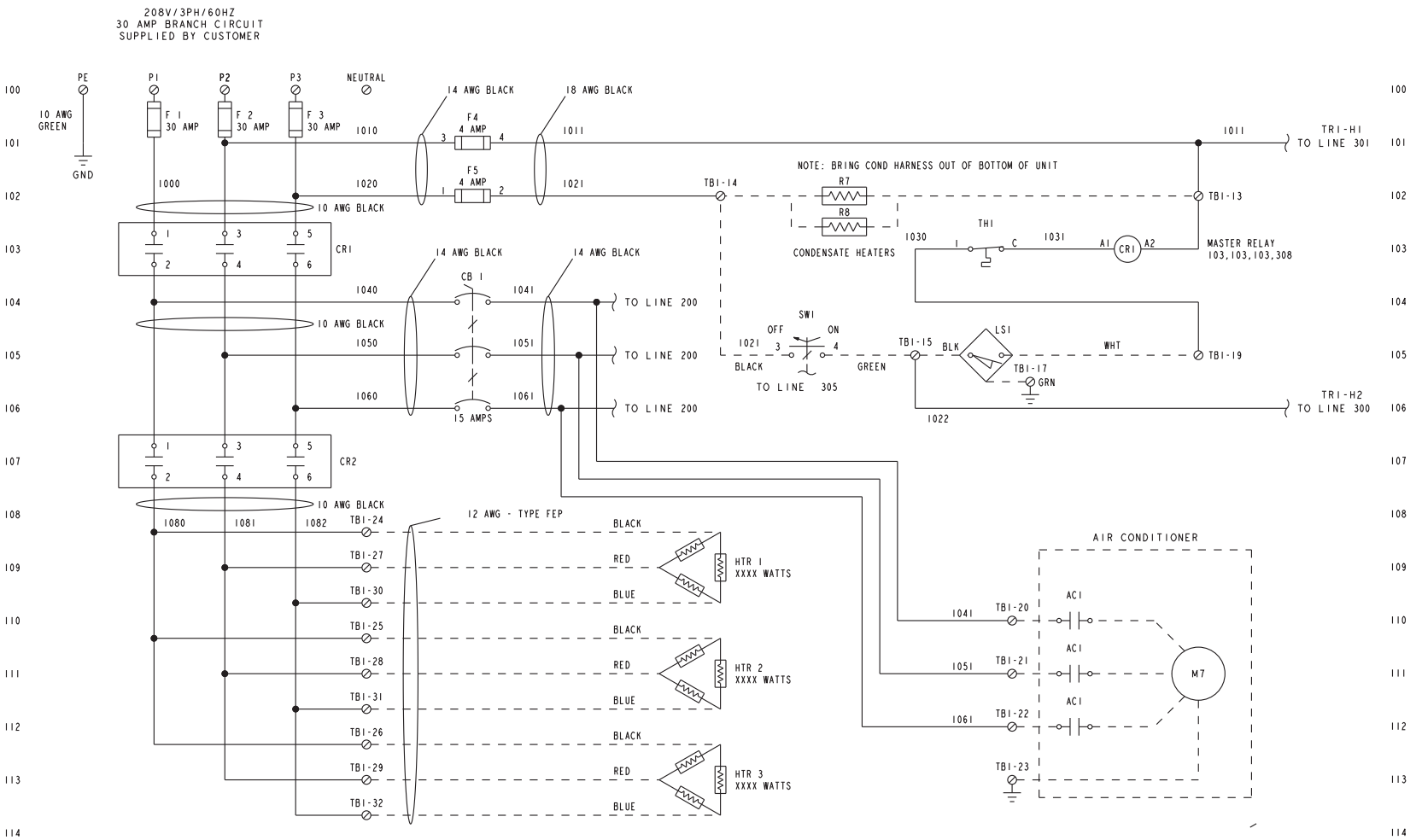

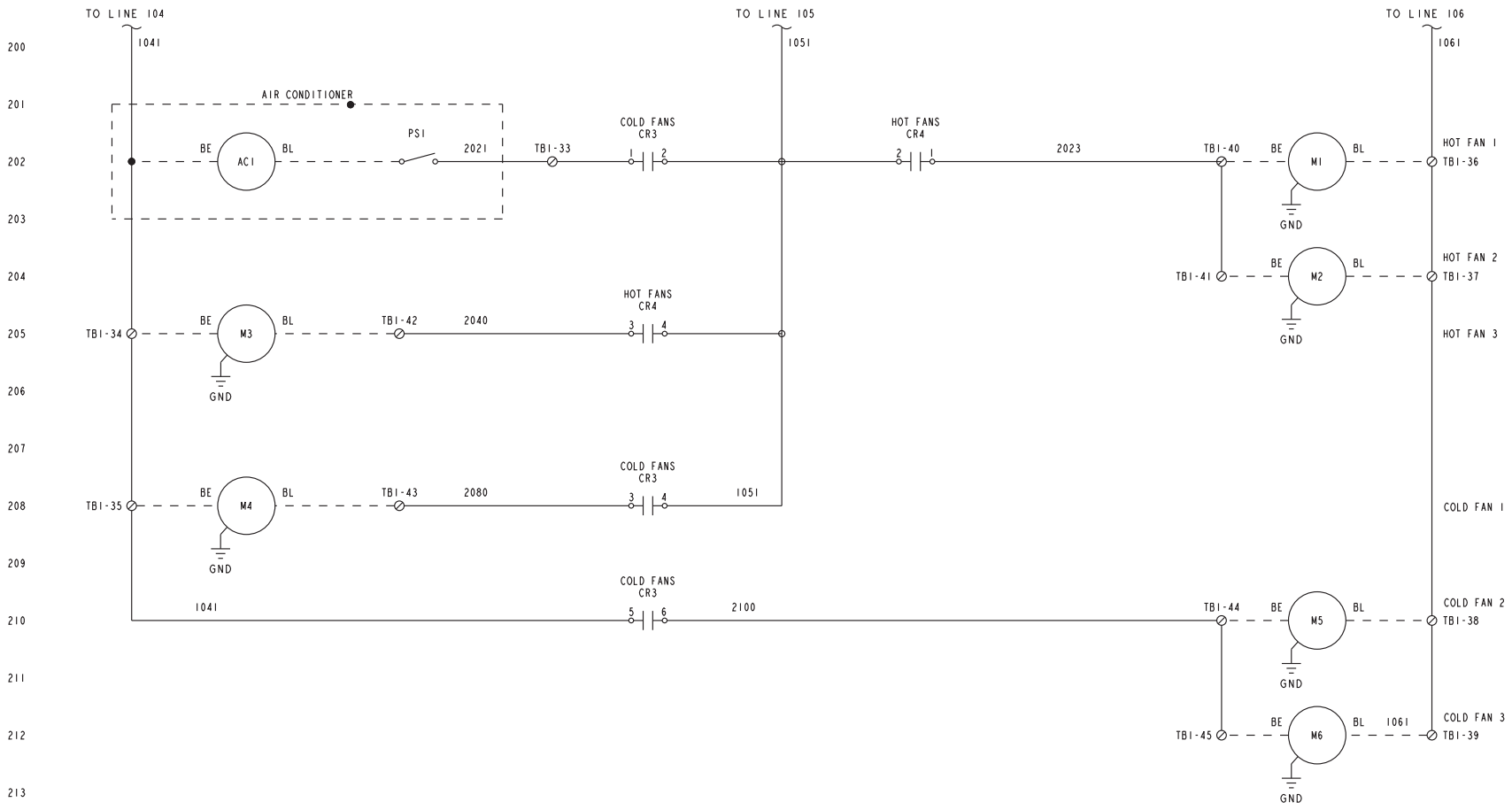



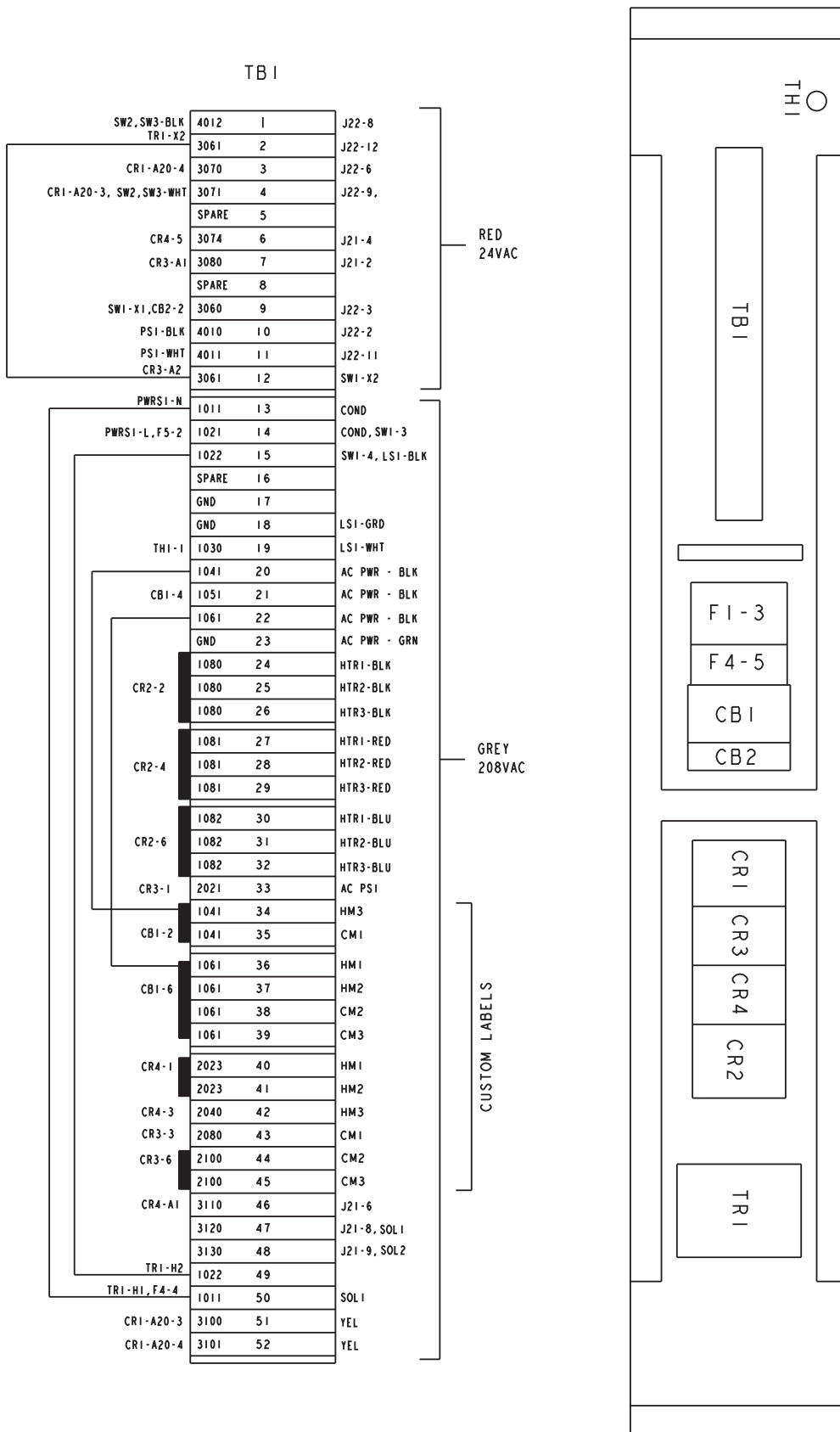

Junior

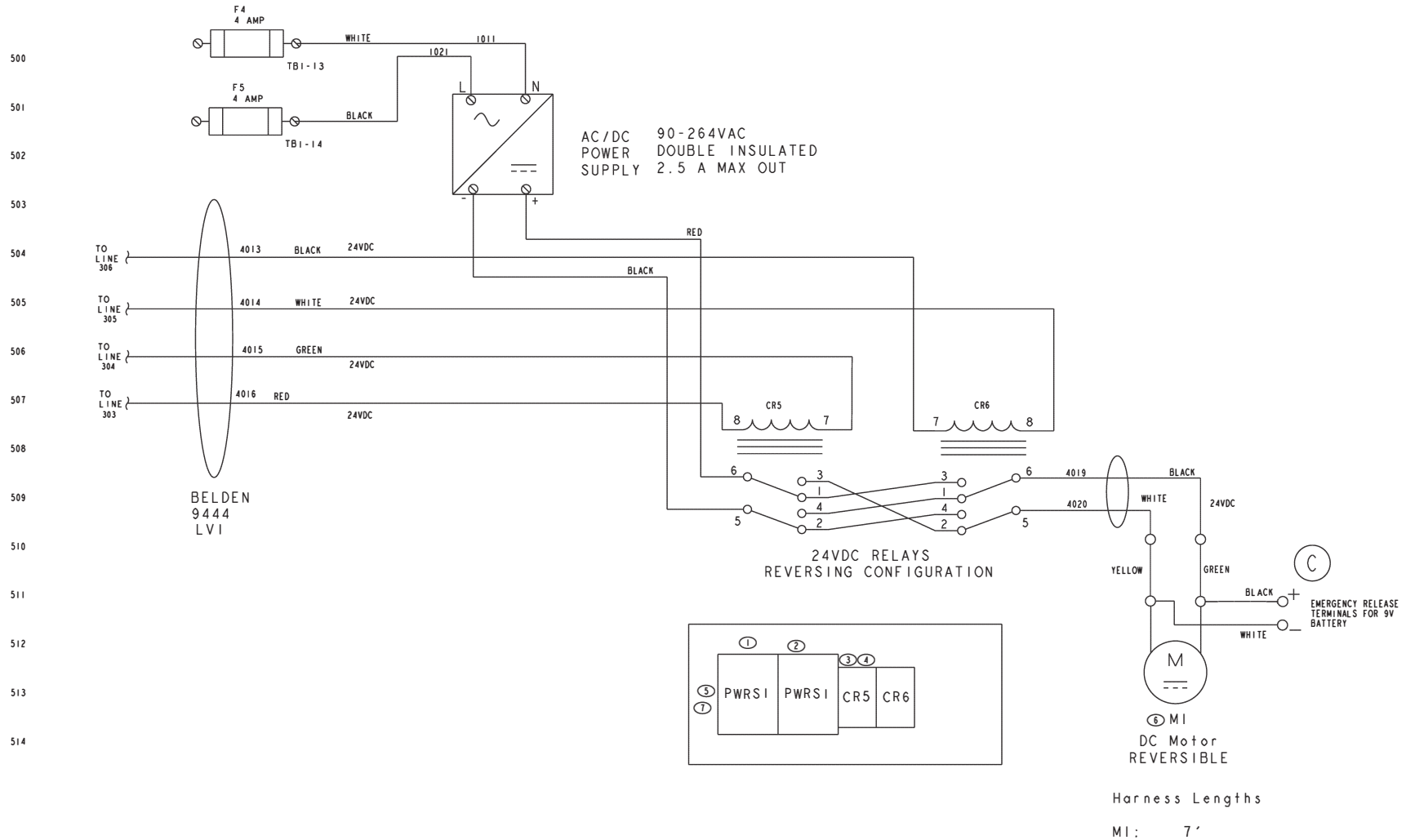

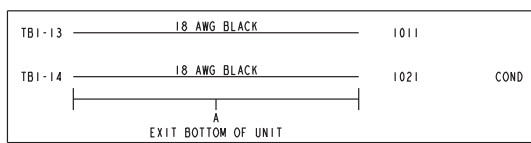
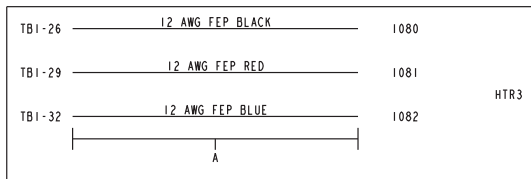
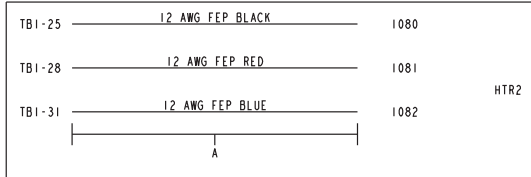
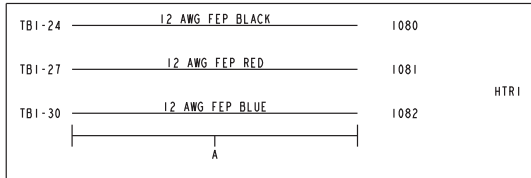
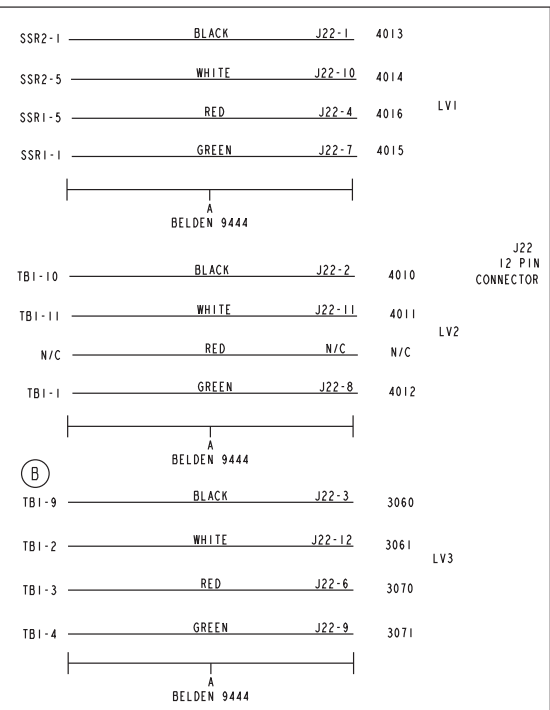
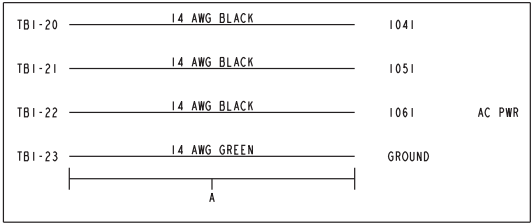
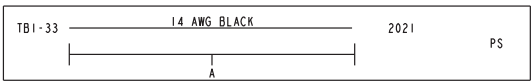
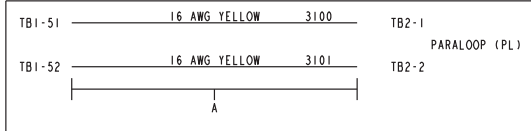
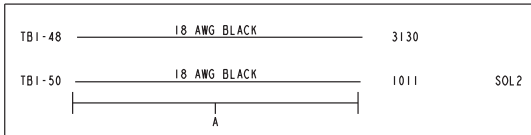
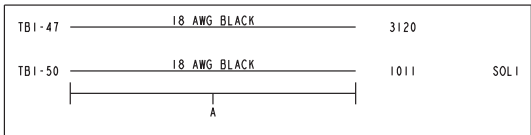
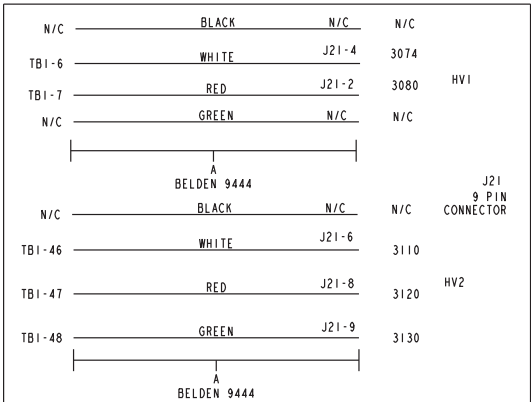
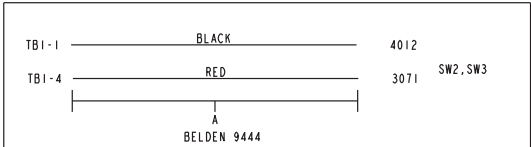
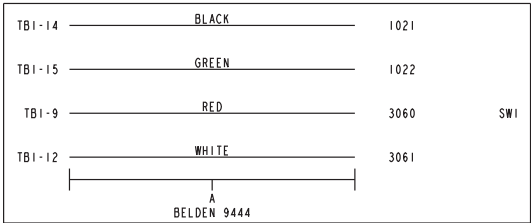

HARNESS LENGTHS		
CABLE	LENGTH	
SW1, SW2, SW3	7'	
PS	7'	
AC PWR	7'	
J21 9PIN CONNECTOR	HV1	7'
	HV2	7'
J22 12PIN CONNECTOR	LV1	7'
	LV2	7'
	LV3	7'
COND	7'	
HTR1	7'	
HTR2	7'	
HTR3	7'	
SV1	7'	
SV2	7'	
PARALOOP (PL)	7'	

OPTIONAL SAFE TEMP II WI-FI WIRING DIAGRAM

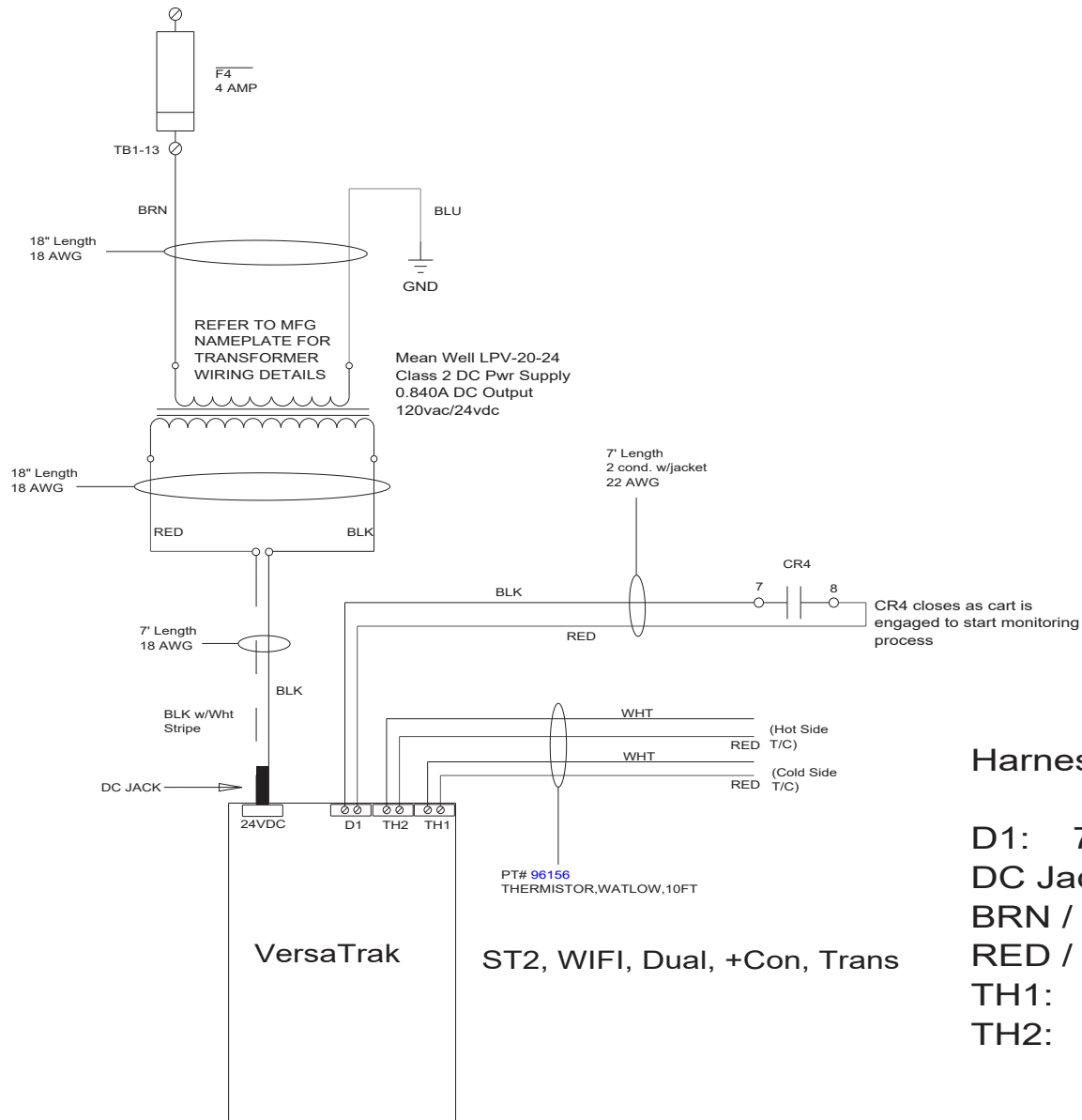

Harness Lengths

- D1: 7'
- DC Jack: 7'
- BRN / BLU: 18"
- RED / BLK: 18"
- TH1: 10'
- TH2: 10'

## EMERGENCY 9 VOLT CART RELEASE

In case of malfunction or prolonged power loss there is a 9 volt emergency release on the lower right side of the dock.



To use, disconnect power to the dock, slide cover to right to expose terminals. Insert a 9 volt battery as shown for 5 seconds to release the cart from the dock. Remove battery and replace cover.

*Note: 9 volt batter NOT included.*

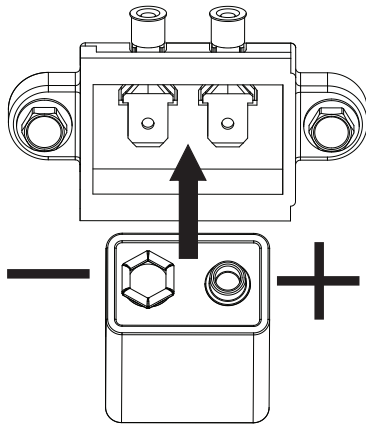

## VII. WARRANTY

ALADDIN TEMP-RITE  
EQUIPMENT  
LIMITED WARRANTY

Effective March 1, 2022

Aladdin Temp-Rite (“ATR”) warrants to the original purchaser that the equipment listed below shall be free from defects in material and workmanship under normal use for the applicable warranty term set forth below. ATR’s obligation under this warranty is limited to the repair or replacement, at the sole option of ATR, of any part which upon inspection and examination by ATR or its authorized agent is found to be defective. A written description detailing the nature of the claimed defect, together with the equipment claimed to be defective if required by ATR, must be delivered to ATR or its authorized agent within 30 days of discovery of the claimed defect (but in no event later than 30 days after the expiration of the applicable warranty term).

CONVECT-RITE 3 EQUIPMENT*	WARRANTY TERMS*		COMPRESSOR WARRANTY TERM* PARTS ONLY**
	PARTS	LABOR	
Convect-Rite 3 Insight DOCKING STATION	1 Year	1 Year	5 Years
Convect-Rite 3 Insight DOCKING STATION HEATING ELEMENTS	2 Years	1 Year	na

\*The warranty term commences 30 days after the date of ATR’s invoice for the equipment. All our reusable crockery such as: plates, dishes, bowls, covers are not included in our manufacture’s equipment warranty.

\*\*The compressor warranty covers the compressor only and does not include any shipping charges, other transportation costs, any external parts or electrical components, labor, refrigerants and taxes. Max 85°F Ambient operating environment.

THE WARRANTIES AND REPRESENTATIONS OF ATR CONTAINED HEREIN ARE EXPRESSLY IN LIEU OF, AND THE BUYER WAIVES, ANY AND ALL OTHER WARRANTIES EXPRESS OR IMPLIED, INCLUDING THE WARRANTIES OF MERCHANTABILITY AND FITNESS FOR A PARTICULAR PURPOSE, AND ANY OTHER REMEDIES AGAINST ATR, WHETHER BASED UPON CONTRACT, NEGLIGENCE, STRICT LIABILITY OR OTHERWISE. ATR SHALL NOT BE LIABLE FOR ANY CONSEQUENTIAL OR INCIDENTAL DAMAGES OR ECONOMIC LOSS OF ANY NATURE (INCLUDING WITHOUT LIMITATION LOSS OF REVENUES AND/OR PROFITS) THAT MAY BE CLAIMED TO RESULT FROM ANY NEGLIGENCE OR BREACH OF WARRANTY OR CONTRACT BY ATR.

### Exceptions and Exclusions

This warranty is issued only to the original purchaser, and is not transferable and applies only to the products installed within the United States of America, its territories and Canada. During the term of any labor warranty, ATR will pay all pre-approved shipping charges incurred in returning defective equipment to ATR and labor costs incurred in the removal and reinstallation of such equipment. Contact ATR before returning any defective equipment or otherwise performing any warranty repairs. ATR assumes no liability for any work or repair performed without its prior approval. After the expiration of any labor warranty, the original purchaser is responsible for all shipping charges incurred in returning defective equipment to ATR and labor for removing and reinstalling such equipment. ATR shall not be responsible for the replacement of expendable items like lamps and fuses or product failure resulting from normal wear and tear, improper installation, misuse, sabotage, abuse, neglect, accident, unauthorized alterations to repair, or other factors beyond the control of ATR. Neither this warranty, nor the liability of ATR may be modified or extended by action of any agent, distributor or other person or by custom or practice.

CALL ATR TOLL FREE AT 1-800-888-5426 IF YOU HAVE ANY QUESTIONS ABOUT THIS WARRANTY OR YOUR ATR PRODUCT.





***Aladdin Temp-Rite***<sup>®</sup>

250 East Main Street, Hendersonville, TN 37075  
1-800-888-8018 • [www.aladdintemprite.com](http://www.aladdintemprite.com) • [info@aladdin-atr.com](mailto:info@aladdin-atr.com)

an Ali Group Company



The Spirit of Excellence