

Aladdin Temp-Rite[®]...better by degrees.

P.O. Box 2978, Hendersonville, TN 37077-2978
1-800-888-8018 or 615-537-3600
Fax 1-888-812-9956
www.aladdintemprite.com



IMX200/IMX300 INSUL-MAX[™] Base Heaters



Model IMX200 Shown

INSTALLATION, OPERATION & MAINTENANCE MANUAL

Manual P/N 97058
Rev. K 10/13/2017

Copyright © 2003 Aladdin Temp-Rite®

Changes may be made to the information in this document without notification.

CONTENTS

- I. MODELS 4
- II. RECEIVING INSPECTIONS 4
- III. INSTALLATION 5
- IV. ELECTRICAL 6
- V. START-UP 7
- VI. CLEANING 8
- VII. TROUBLESHOOTING 9
- VIII. PARTS LIST/DIAGRAMS 10
- IX. PREVENTATIVE MAINTENANCE 14
- X. SERVICE 15
- XI. WARRANTY 15

IMX 200/IMX 300

CONVECTED AIR INSUL-MAX™ BASE HEATERS

I. MODELS

The Aladdin Temp-Rite® Convected Air Insul-Max™ Base Heaters are available in two capacities. These units are designed specifically for use with the Aladdin Insul-Max™ bases.

The Aladdin Temp-Rite® Convected Air Insul-Max™ Base Heaters are mobile, modularly designed products which are able to be used independently or in conjunction with other units in a tray line arrangement.

Aladdin Sales Codes	IMX 200	IMX 200A	IMX 200E	IMX 300	IMX 300A	IMX 300E
Number of Stacks	2	2	2	3	3	3
Capacity per Stack	33	33	33	33	33	33
Capacity (Total)	66	66	66	99	99	99

Overall Dimensions:

Length	33-3/4"	33-3/4"	33-3/4"	47-1/8"	47-1/8"	47-1/8"
Width	24-1/2"	24-1/2"	24-1/2"	24-1/2"	24-1/2"	24-1/2"
Height	42-13/16"	42-13/16"	42-13/16"	42-13/16"	42-13/16"	42-13/16"

Electrical Requirements:

Voltage / Phase	208V /1	240V/1	240V/1	208V /1	240V/1	240V/1v
Amperage	16	14	15	16	14	15
Cycle	60	60	50	60	60	50
NEMA Plug Configuration	6-20P	6-20P	none	6-20P	6-20P	none
Approximate Shipping Weight	270 lbs.	270 lbs.	270 lbs.	300 lbs	300 lbs.	300 lbs

II. RECEIVING INSPECTIONS

NOTE: All Aladdin Temp-Rite® units are factory tested for performance and certified free from defects and customer ready prior to shipment.

You should carefully inspect your to assure that no damage has occurred in transit. If however, damage is detected see the following damaged goods policy. Under no condition may a damaged unit be returned to Aladdin Temp-Rite without first obtaining written permission (return authorization). No credit will be issued for claims not reported to Aladdin within ten (10) business days from receipt of shipment.

ALADDIN DAMAGED GOODS POLICY

There are two types of damaged merchandise:

- Visual Damage
- Concealed Damage

Visual Damage – When the product being received is visibly damaged.

1. Receiver should not accept merchandise with visual damage.
2. Receiver must sign delivery receipt “refused merchandise due to damage” and specify damage.
3. Receiver should call Aladdin Customer Service immediately after refusal.
4. Carrier will notify Aladdin Traffic Department and a claim will be filed.
5. Carrier will send acknowledgement of claim within 7 days after receiving.

Concealed Damage – When damaged merchandise cannot be externally detected.

Any receiving operation should be looking for this type of damage. Sometimes, however, depending on the type of product, it is almost impossible to notice.

1. Merchandise must not be removed from point of delivery and all packaging must be kept intact.
2. Receiver must contact Aladdin customer service to report damage.
3. Aladdin traffic department will request inspection based on the dollar value of the cargo.
4. Aladdin traffic department will file a claim based on the findings of the inspection.

Failure to comply with these policies will result in the customer’s responsibility to file claims.

III. INSTALLATION



NOTE: The installation instructions are similar for both heaters.

- A. All models are equipped with self-leveling mechanisms that are removable through the top of the unit. No adjustments are required to the tension springs as they are preset at the factory.
- B. See ELECTRICAL (section IV) and START-UP (section V) before plugging unit into power supply.

IV. ELECTRICAL

Refer to the specifications data on page 4, the serial tag, your local code or the National Electrical Code to be sure the unit is connected to the proper power source. A protected circuit of the correct voltage and amperage must be available for connection of the line cord.

All Insul-Max™ base heaters are provided with a NEMA plug type 6-20P.

 WARNING 
Every heater is fitted with a grounded power cord and must be connected to a properly grounded receptacle. Each receptacle must be wired to a dedicated circuit breaker rated at not more than 20 amps.

 WARNING 
To prevent electrical shock hazard, the main power switch must be turned to "off " position and the heater disconnected from the power source whenever performing service or maintenance.

 WARNING 
Hazardous voltage inside back of cabinet. Only qualified personnel totally familiar with electrical circuits, service manual and service procedures should open or work inside unit.

The purchaser/user has the best knowledge and is in the best position to determine the operating conditions, appropriateness of the product for the operating environment, and safe use of the product. Aladdin Temp-Rite does not warrant, implied or expressly, that the product is fit for a particular use or operating environment.

V. START-UP

A. OVERVIEW

These units are designed to heat Insul-Max™ bases only. Once the unit is turned on, the fan motor, heater and power indicator light will come on. There is a power indicator light to let the operator know the power is on.

The fan motor will begin to circulate the heated air in and around the bases in a convection process that promotes a quick and even heat absorption by the bases.

Once the air inside the cabinet has reached the desired and preset temperature, the thermostat will continue to maintain this temperature by regulating the power to the heater. The fan motor will run as long as the unit is energized.

B. LOADING

Load carrier platform by carefully stacking the bases in each cavity. Always keep the load leveled on the platform or it may bind. Never try to exceed the recommended base capacities that are shown in the models chart on page 4.

C. POWER

Set the power switch to the "ON" position. The power switch will light up when the unit is on. Keep the cover closed completely to insure proper and efficient heating. The heater should always be turned on 120 minutes before dispensing.

D. DISPENSING

After the unit is turned off or unplugged, the bases remaining inside the unit will remain hot for some time. Leave the lid open to allow the unit and its contents to cool.



Operators should always wear gloves or use base lifters when dispensing bases.

VI. CLEANING

The following procedures should be followed during the regular cleaning regimen on all of the base heaters.

1. Turn the unit off and disconnect the plug from the outlet, and allow the cabinet to cool. Remove plug by pulling it straight out. **Never pull on the cord.**
2. Pull the spring loaded dispenser mechanism up and out, place it on a work surface. You can now wipe down the mechanism with a damp cloth to clean it.
3. Clean out any debris inside the cabinet and wipe the cabinet down with a damp cloth.
4. Place the spring loaded dispenser mechanisms back inside the cabinet and clean the outside of the cabinet with a mild, non-abrasive soap or detergent in a warm water solution. A commercial stainless steel cleaner can also be used for this procedure.
5. After the heater has been thoroughly cleaned and dried with a soft cloth the plug can be replaced.

NOTE: Do not use abrasives, harsh chemicals, or chlorine products for cleaning.

 WARNING 
Do not steam or pressure clean or hose down the cabinet. This could damage the equipment and possibly cause an electrical shock to the operator.

 WARNING 
Repairs to be done by qualified service personnel only.

VII. TROUBLESHOOTING

COMPLAINT	PROBLEM	SOLUTION
A. Unit does not operate and no lights are on	1. No power	1. Make sure plug is connected and switch is ON. Check for power to the receptacle
	2. Bad power switch	2. Replace power switch
	3. Loose wiring	3. Check and secure wiring
B. Unit heats, but fan does not operate	1. Defective motor	1. Replace motor
	2. Jammed or loose fan blade	2. Replace or tighten blade
	3. Loose wiring	3. Determine fault and correct
C. Unit does not heat, but fan operates	1. Defective heating element	1. Replace heating element
	2. Open high limit switch	2. Replace switch. Check for causes before restarting equipment
	3. Loose wiring	3. Check and secure wiring
D. Base temperature is too low, fan operating	1. Jammed or loose fan blade	1. Replace or tighten blade
	2. Cover is open	2. Close cover
E. Base temperature is too high, fan is operating	1. Closed thermostat	1. Replace thermostat
	2. Closed high limit switch	2. Replace high limit switch
F. Cover is loose	1. Hinge screws are missing or loose	1. Replace or tighten screws
G. Dispenser Binds	1. Improper springs	1. Check springs chart and use correct number of springs. Make sure identical number and size of springs are on each side of dispenser
	2. Debris on guide rods	2. Clean off debris
H. Cabinet does not roll easily	1. Debris on wheel or axle	1. Clean out debris
	2. No lubrication	2. Lubricate axles with load bearing grease. Lubricate swivel bearings with 30-weight oil.

VIII. PARTS LIST/DIAGRAMS

Item#	DESCRIPTION	ALADDIN PART#	IMX200	IMX300
1	Lid assembly-End	92496	2	2
2	Lid assembly-Center	92497	-	1
3	Hinge, RH & LH	92203	4	6
4	Lid handle	92500	2	3
5	Push/Pull handle	92501	1	1
6	Rear louvered panel IMX 200	10554	1	-
7	Rear louvered panel IMX 300	10553	-	1
8	Cord-10 foot length	94837	1	1
9	Plug-NEMA 6-20 straight blade	92504	1	1
10	Corner Bumper	93052	4	4
11a	On/off switch	97539	1	1
11b	Switch guard	10570	1	1
12	Motor-208/230V,60hz. 1ph. 3200 rpm	13068	1	1
13	High limit switch- manual reset 350°F	96392	2	2
14	Thermostat-320°F, non-adjustable	97319	1	1
15	Heating element-208V	92510	1	1
16	Fan Blade, 5/16" bore	92512	1	1
17	Caster 5" swivel	97223	2	2
18	Caster 5" swivel with brake	92516	2	2
19	Elevator spring	93104	14	21
20	Elevator bushing	10816	8	12
21	Elevator guide rod	10638	4	6
22	Elevator assembly	93105	2	3
23	Heating element-240V ("E" Models ONLY)	92511	-	-
24	Heating element-240V ("A" Models ONLY)	98220	1	1

IMX200 EXPLODED VIEW DRAWING

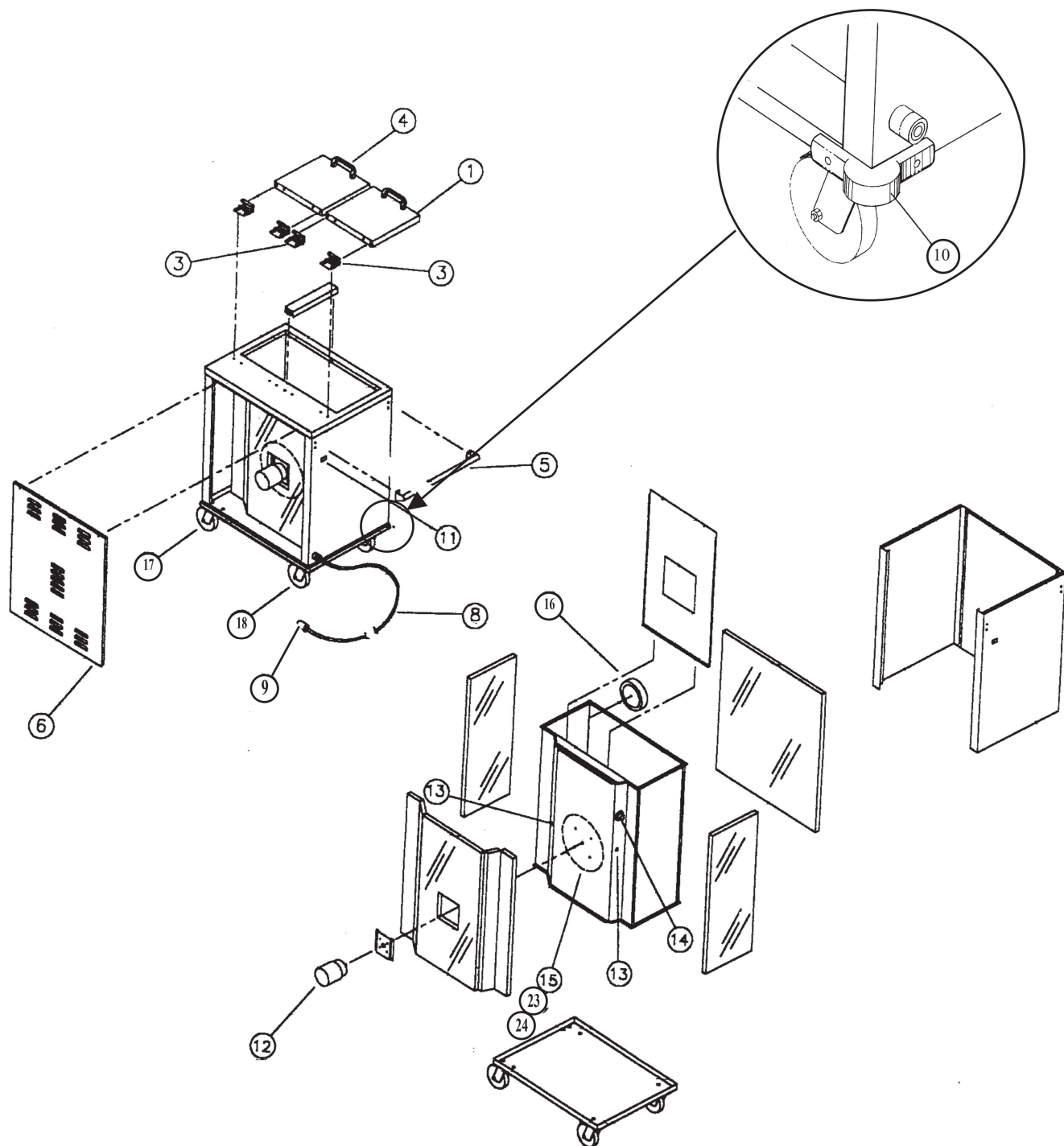

IMX 200/IMX 300

CONVECTED AIR INSUL-MAX™ BASE HEATERS

IMX300 EXPLODED VIEW DRAWING

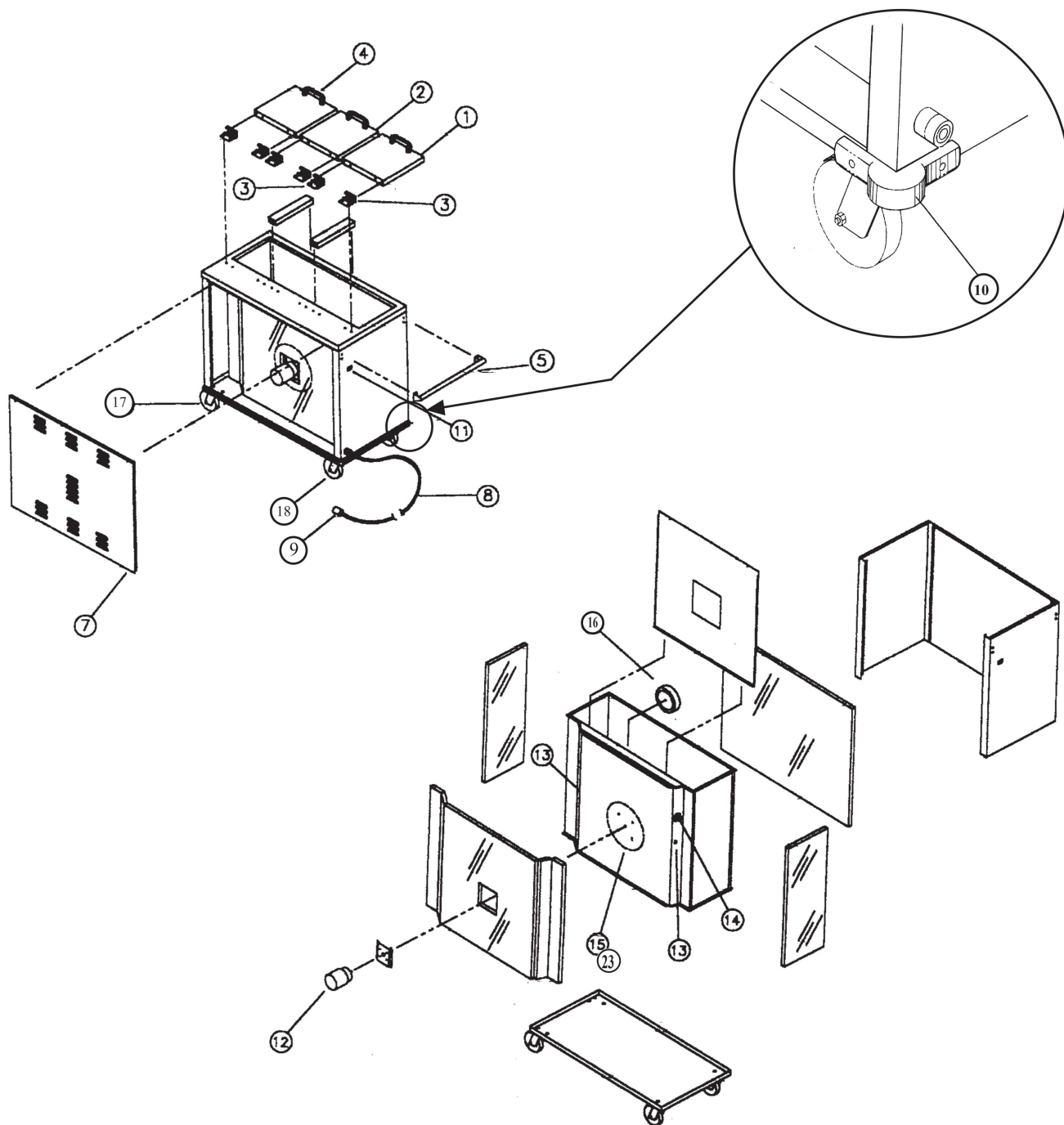

IMX 200/IMX 300 ELEVATOR ASSEMBLY EXPLODED VIEW DRAWING

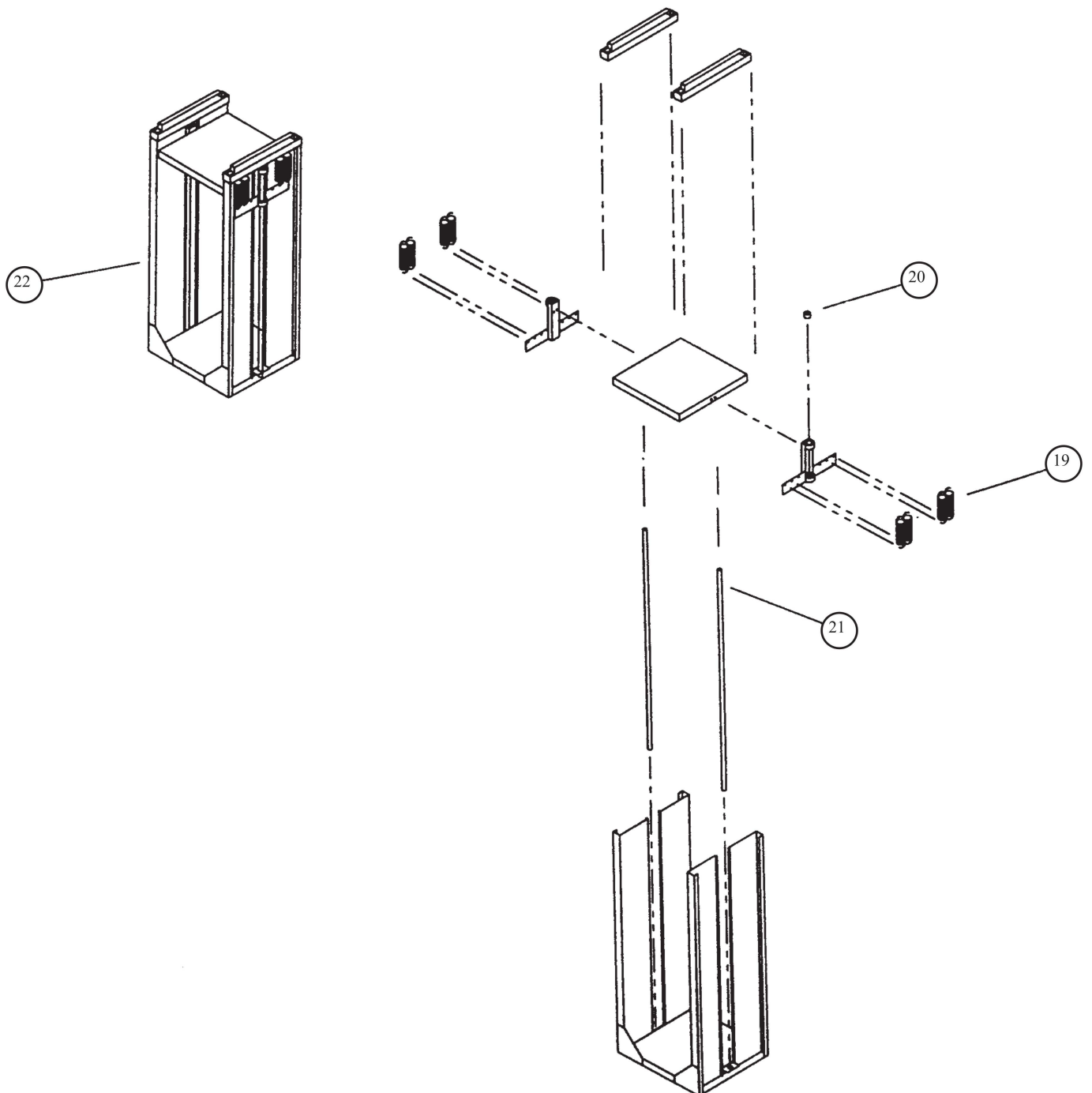

IMX 200/IMX 300

CONVECTED AIR INSUL-MAX™ BASE HEATERS

WIRING DIAGRAM

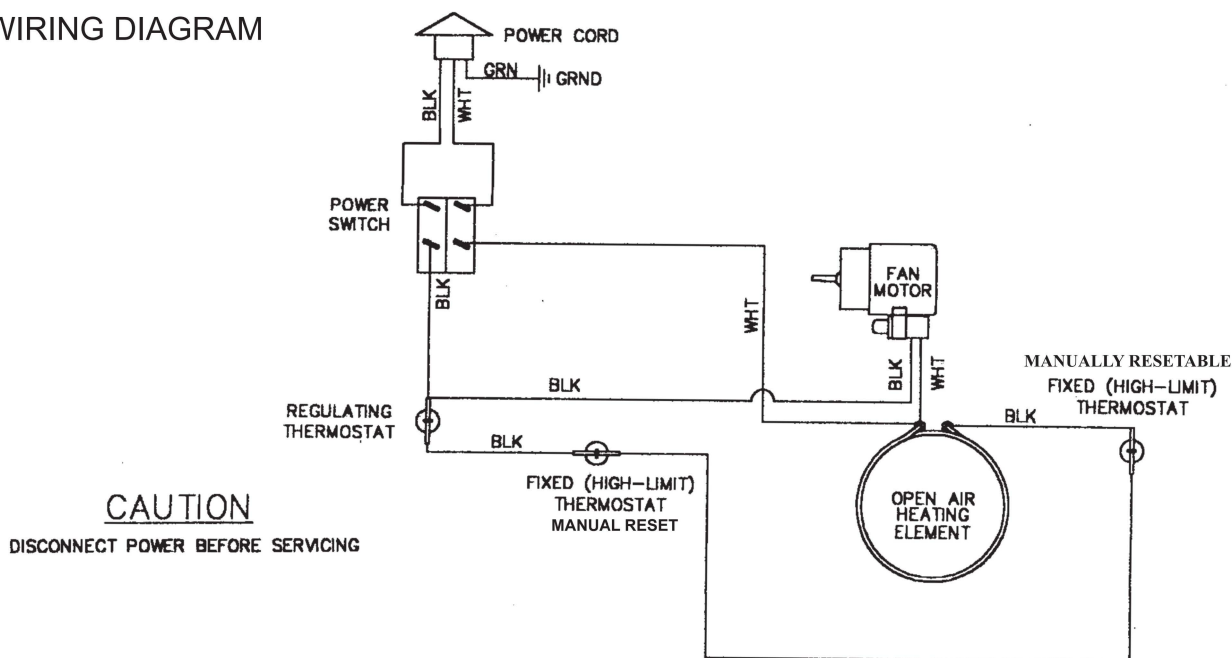

IX. PREVENTATIVE MAINTENANCE

CASTERS

1. Check casters for freedom of movement and proper brake retention.
2. Maintain casters free of debris. (mop strings, paper plastic, hair nets, etc.)
3. Clean or replace as required.
4. Replace caster when rubber tread is less than ¼" from rim.

CORD & PLUG

1. Inspect plug blades for distortion and replace if any blades are missing, bent or broken.
2. Inspect cord wiring for integrity at termination points by having qualified service person remove the back panel from cabinet. Make sure the cord sheathing extends into the cabinet interior. If wires are showing on the outside of the cabinet, remove the unit from use and have repairs made before turning on power to the unit.

DISPENSING MECHANISM

1. Periodically check springs for proper base dispensing by filling each cavity with bases and checking to see that it indexes as bases are removed. If bases do not index properly and the unit is not overloaded, remove the dispenser from the unit. Aladdin has included an extra spring on each dispenser that is not connected to the mechanism on one end. Connect the extra spring which will bring the total number of springs to eight per dispenser. Test the unit again for proper base dispensing and if the additional spring does not correct any lifting problems, replace all the springs.

X. SERVICE

In the event service is required on your Aladdin IMX200/IMX300 Series Base Heaters please call: **ALADDIN TEMP-RITE® SERVICE DEPARTMENT AT 1-800-888-5426.**

XI. WARRANTY

ALADDIN TEMP-RITE®
EQUIPMENT
LIMITED WARRANTY

Effective March, 2003

Aladdin Temp-Rite® ("ATR") warrants to the original purchaser that the equipment listed below shall be free from defects in material and workmanship under normal use for the applicable warranty term set forth below. ATR's obligation under this warranty is limited to the repair or replacement, at the sole option of ATR, of any part which upon inspection and examination by ATR or its authorized agent is found to be defective. A written description detailing the nature of the claimed defect, together with the equipment claimed to be defective if required by ATR, must be delivered to ATR or its authorized agent within 30 days of discovery of the claimed defect (but in no event later than 30 days after the expiration of the applicable warranty term).

EQUIPMENT	WARRANTY TERM*	
	PARTS	LABOR
IMX200,200A, 200E, 300, 300A,300E	1 year	90 Days

*The warranty term commences 30 days after the date of ATR's invoice for the equipment.

**The compressor warranty covers the compressor only and does not include any shipping charges, other transportation costs, any external parts or electrical components, labor, refrigerants and taxes.

THE WARRANTIES AND REPRESENTATIONS OF ATR CONTAINED HEREIN ARE EXPRESSLY IN LIEU OF, AND THE BUYER WAIVES, ANY AND ALL OTHER WARRANTIES EXPRESS OR IMPLIED, INCLUDING THE WARRANTIES OF MERCHANTABILITY AND FITNESS FOR A PARTICULAR PURPOSE, AND ANY OTHER REMEDIES AGAINST ATR, WHETHER BASED UPON CONTRACT, NEGLIGENCE, STRICT LIABILITY OR OTHERWISE. ATR SHALL NOT BE LIABLE FOR ANY CONSEQUENTIAL OR INCIDENTAL DAMAGES OR ECONOMIC LOSS OF ANY NATURE (INCLUDING WITHOUT LIMITATION LOSS OF REVENUES AND/OR PROFITS) THAT MAY BE CLAIMED TO RESULT FROM ANY NEGLIGENCE OR BREACH OF WARRANTY OR CONTRACT BY ATR.

Exceptions and Exclusions

This warranty is issued only to the original purchaser, and is not transferable and applies only to the products installed within the United States of America, its territories and Canada. During the term of any labor warranty, ATR will pay all pre-approved shipping charges incurred in returning defective equipment to ATR and labor costs incurred in the removal and reinstallation of such equipment. Contact ATR before returning any defective equipment or otherwise performing any warranty repairs. ATR assumes no liability for any work or repair performed without its prior approval. After the expiration of any labor warranty, the original purchaser is responsible for all shipping charges incurred in returning defective equipment to ATR and labor for removing and reinstalling such equipment. ATR shall not be responsible for the replacement of expendable items like lamps and fuses or product failure resulting from normal wear and tear, improper installation, misuse, sabotage, abuse, neglect, accident, unauthorized alterations to repair, or other factors beyond the control of ATR. Neither this warranty, nor the liability of ATR may be modified or extended by action of any agent, distributor or other person or by custom or practice.

CALL ATR TOLL FREE AT 1-800-888-5426 IF YOU HAVE ANY QUESTIONS ABOUT THIS WARRANTY OR YOUR ATR PRODUCT.