

Aladdin[®]

Aladdin Synergetics, Inc.
Nashville, TN 37214
1-800-888-8018

J612 & J614 SERIES HOT FOOD COUNTERS

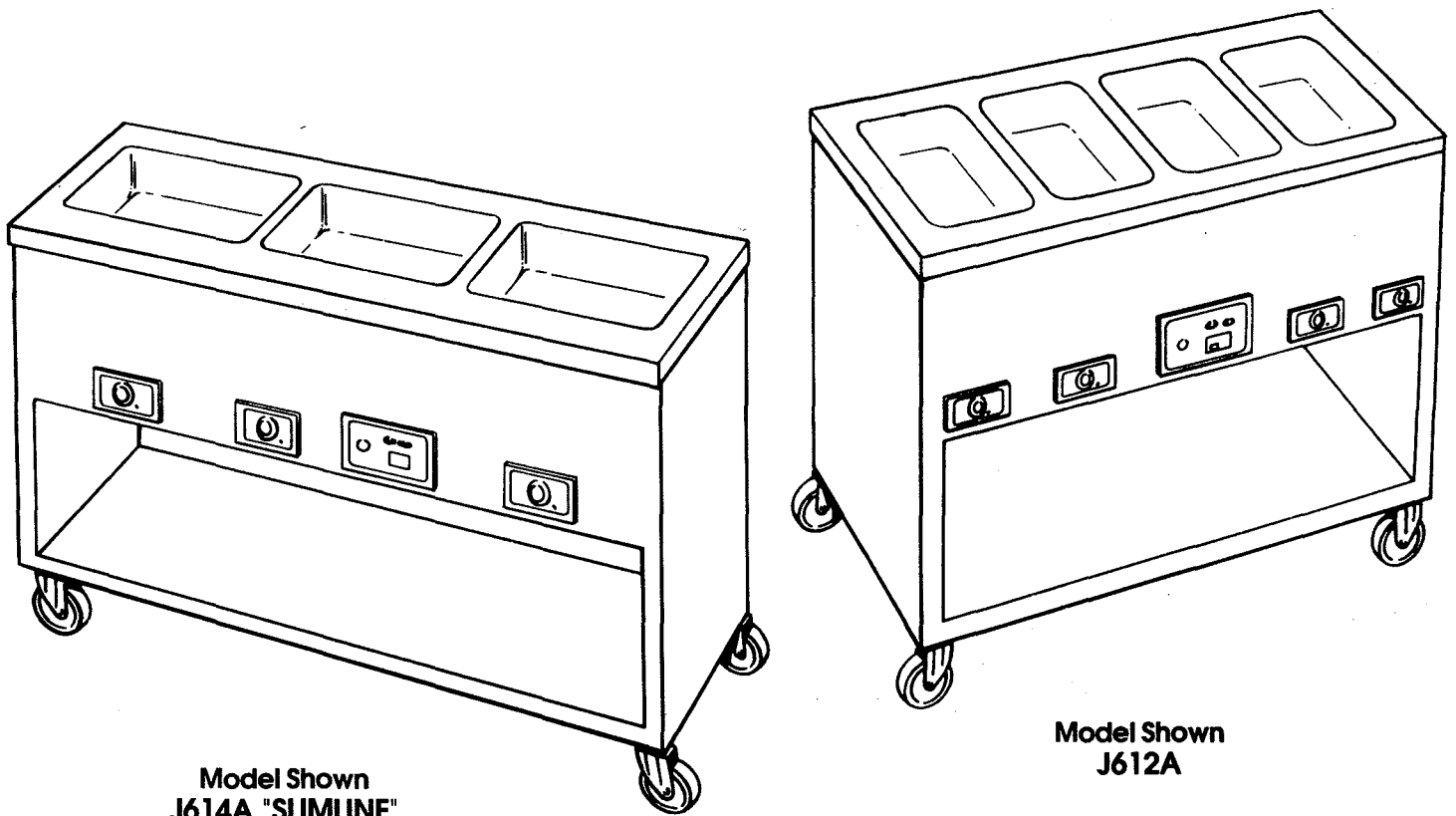

Model Shown
J614A "SLIMLINE"

Model Shown
J612A

INSTALLATION, OPERATION & MAINTENANCE MANUAL

Manual P/N 34974

J612, J614 SERIES HOT FOOD COUNTERS

I. MODELS

The Aladdin J612 & J614 series Hot Food Counters contain five different models in the J612 line and four different models in the J614 "Slim-Line" series.

All Aladdin Hot Food Counters are mobile modularly designed products which are able to be used independently or in conjunction with other units in a cafeteria line arrangement.

Aladdin Sales Codes Description	J612 3-well	J612A 4-well	J612B 5-well	J612L L-shaped 4-well left	J612R L-shaped 4-well right
Overall Dimensions:					
Length	48"	60"	74"	48"	48"
Width**	30"	30"	30"	30"	30"
Counter Height					
Height with optional 1 tier	51 1/4"	51 1/4"	51 1/4"	51 1/4"	51 1/4"
Height with optional 2 tiers	64"	64"	64"	64"	64"
*Electrical Requirements:					
Voltage	208V	208V	208V	208V	208V
Amperage	14.42A	19.23A	24.03A	19.23A	19.23A
Standard NEMA Plug	6-20P	6-30P	6-30P	6-30P	6-30P
Approximate Shipping Weight without options	345 lbs.	450 lbs.	495 lbs.	550 lbs.	550 lbs.

NOTE: If required power is other than 208V/1PH, voltage and phase must be specified.
***Electrical requirements and NEMA plug will change with added electrical options-(heat lamps & convenience outlet)**
****The overall width with optional 6" wide workshelf is 36" on J612, J612A, J612B**

Aladdin Sales Codes Description (Slim-Line MODELS)	J614 2-well	J614A 3-well	J614L L-shaped 4-well left	J614R L-shaped 4-well right
Overall Dimensions:				
Length	48"	70"	70"	70"
Width	22"	22"	38"	38"
Counter Height	37"	37"	37"	37"
*Electrical Requirements:				
Voltage	208V	208V	208V	208V
Amperage	9.6A	14.42A	19.23A	19.23A
Standard NEMA Plug	6-15P	6-20P	6-30P	6-30P
Approximate Shipping Weight without options	330 lbs.	400 lbs.	500 lbs.	500 lbs.

NOTE: If required power is other than 208V/1PH, voltage and phase must be specified.
***Electrical requirements and NEMA plug will change with added electrical options-(heat lamps & convenience outlet)**

II. RECEIVING INSPECTIONS

NOTE: All Aladdin® units are factory tested for performance and certified free from defects and user ready prior to shipment.

Upon receipt, the crate should be inspected for visual damage, any damage should be reported immediately to the carrier.

ALADDIN DAMAGED GOODS POLICY

There are two types of damaged merchandise: **A. VISIBLE DAMAGE** **B. CONCEALED DAMAGE**

A. VISIBLE DAMAGE- (The product being received is visibly damaged).

1. The receiver should refuse the damaged merchandise.
2. Receiver should sign packing slip "refused merchandise due to damage" when receiving partial shipment.
3. Contact Aladdin Customer Service Representative and alert to the situation.

B. CONCEALED DAMAGE- (Damaged merchandise cannot be externally detected). Any receiving operation should inspect for this type of damage. Sometimes, however, depending on the type of product, it is almost impossible to notice.

IF PRODUCT IS DAMAGED:

1. Save all packing material.
2. Contact Aladdin Customer Service Representative and alert to the situation.
3. Receiver must call the carrier to schedule an inspection of the damaged merchandise before Aladdin can file a claim with the carrier.

III. INSTALLATION INSTRUCTIONS

The Aladdin J612 and J614 series Hot Food Serving Counters are self-contained units for holding and dispensing hot food. The design of this unit allows for maximum mobility, where the units can be arranged in the most productive position and easily moved for cleaning or maintenance purposes.

Simply position the unit in its place of operation and connect it to the proper power supply. **Refer to the "Operating Instructions" before energizing the unit.**

J612, J614 SERIES HOT FOOD COUNTERS

IV. OPERATING INSTRUCTIONS

A. HOT FOOD SECTION

The food warming unit is designed for holding or warming pre-cooked food. It will not over cook food when properly used. There are three ways of maintaining hot food in the food well: (1) Dry Heating, (2) Steam Heating or (3) Hot Water Heating.

1. DRY HEATING

- a. Place the control knob on the desired position and allow the food well to preheat for 15 to 20 minutes.
- b. Place the container of food in the food well, keep the food covered when not serving.

2. STEAM HEATING (See section V page 9 for draining & cleaning instructions).

- a. Place cold water or (hot water for a faster pre-heat) into the receptacle, to a depth that will allow for a 1" space between pan and water surface. Set the thermostat to a position for moderate boiling. Cover the receptacle with an empty food pan or a food pan cover until the water boils.
- b. Place the container of food in the receptacle. Keep the food covered when not being served.
- c. Adjust the thermostat to a point where the water just boils.
- d. Add water as needed during operation.

CAUTION: Should all of the water boil out of the receptacle, **DO NOT** refill the receptacle with water until the receptacle has cooled down. Placing water in a hot receptacle that is empty can damage the receptacle!

3. HOT WATER HEATING (See section V page 9 for draining & cleaning instructions).

- a. Fill the receptacle with hot water to a depth that allows the food container to make contact with the water.
- b. Set the thermostat to a high position and cover the receptacle with an empty food pan or a food pan cover until the water boils.

- c. Lower the setting on the thermostat slightly so that the water temperature is just below the boiling point.
- d. Place the container of food in the receptacle. Keep the food covered when not serving.
- e. Add water as needed during operation

CAUTION: Should all of the water boil out of the receptacle, **DO NOT** refill the receptacle with water until the receptacle has cooled down. Placing water in a hot receptacle that is empty can damage the receptacle!

NOTES:

Exact dial settings to maintain desired food temperature will vary with the character of the food, such as whether or not the food has a high water content or has a considerable amount of grease. The most satisfactory temperature setting must be determined by experience.

With steam and hot water heating, the drying out of food is minimized because the water vapor from the receptacle creates humid air over the food.

B. THERMOSTAT

The thermostat bulb is clamped to the outside of the base of the receptacle. A capillary tube extends from the bulb to the thermostat control. Whenever the heating unit is energized, the pilot light will illuminate. It goes off when the preset temperature is reached. The cycling of the thermostat is therefore indicated by the pilot light.

C. SHUTDOWN

At the end of the day or food serving period, turn the thermostat controls to the off position. This removes all power to the heating units. To shut off the equipment for long periods of time or prevent the unauthorized use of equipment, turn off the switch that controls power to the table
CAUTION: When the Hot Food Counter is to be used, be sure that it is turned on before adjusting the thermostat control(s).

J612, J614 SERIES HOT FOOD COUNTERS

V. CLEANING

A. HOW TO CLEAN STAINLESS STEEL

1. WHEN TO CLEAN

It is recommended that all stainless steel equipment be cleaned on a regular basis. Any piece of stainless steel equipment that is soiled should be cleaned daily to ensure the long life of the equipment. Routine cleaning will lessen stainless steel abrasion.

2. HOW TO CLEAN

To remove most soil, use a nonabrasive, non-chlorinated soap solution. Rinse thoroughly with warm water and wipe dry using an absorbent cloth. *TO REMOVE HEAVY SOIL, RUB THE AREA WITH A NON-METALLIC, FINE GRAIN SCOURING CLOTH.* Be sure to rub in the same direction as the metal grain. Rinse thoroughly with warm water and wipe using a soft absorbent cloth. As a final step, a stainless steel polish may be used. The polish will shine the stainless steel and provide a protective finish that will reduce future soiling.

3. CLEANING SAFEGUARDS

Always rub with the metal grain. *NEVER USE STEEL WOOL OR METALLIC SCOURING CLOTHS.* This will help prevent scratching and possible damage to the surface finish.

Use recommended dilution. Do not exceed concentration levels which may cause long term deterioration of surface. Be certain to rinse thoroughly to prevent build-up of cleanser.

NEVER USE CHLORINE OR BLEACH SOLUTIONS. Check the ingredients of cleaning solutions or disinfectants used as they may contain chlorinated solvents.

Always read the label of the cleaning solutions. Check for warnings about use on stainless steel products. Repeated use of chlorinated solvents may cause a chemical reaction with the stainless steel, which will damage the surface and cause rusting.

4. STERILIZING STAINLESS STEEL

When sterilizing stainless steel equipment, pay particular attention to agents containing chlorine compounds such as potassium hypochlorite. These compounds may break down and release free chlorine or hydrolyze to form hydrochloric acid. Stainless steel resists attack by the compounds for up to two hours. Severe localized pitting may occur with longer exposure. For safe use of the agents, keep contact time short, flush thoroughly with water and operate equipment normally between applications. Using these precautions, the sterilization process can be repeated any number of times.

B. HOT FOOD WELLS

Wet Operation: If hot water or steam operation is used, all surfaces are covered with a film of water, so that food spillage into the receptacle will not stick or carbonize. It will drop into the water and float or settle to the bottom. To clean the receptacle, turn the unit off, move the unit to a floor drain and open the drain valve (located on the bottom side of the unit under the receptacle area) to drain the water from the receptacles, remove the remaining water with a towel or sponge. The water can also be removed by placing a full size 4" deep pan under the drain spigot to catch the water. The pan will have to be emptied and replaced until the receptacles are empty. Another method to drain the receptacles is to attach a hose to the spigot and insert the opposite end into the floor drain before opening the valve. Wash the receptacle with a detergent and hot water, rinse and dry. (See how to clean stainless steel, Page 8)

Dry Operation: When the food warmer is used dry, food spillage on the hot surfaces will burn and stick. The same commercial cleaners used on stainless steel utensils may be used to clean the receptacle. Wash the interior surfaces with water and a detergent to remove mild discolorations. Rinse with plain water and dry with an absorbent cloth. The bottom of the receptacle may take on a straw colored appearance when it is used dry. This is due to the intense heat, which causes stainless steel to discolor. This discoloration will not come off with normal cleaning procedures, but poses no problems. (See how to clean stainless steel, Page 8).

WARNING: Do not use harsh chemicals, acids or alkalis in the cleaning of this table.

NOTE: The food warmer receptacle is made of stainless steel, but use care during the cleaning operation. Heavy objects should not be dropped in the receptacle.

For more information on cleaning see the section "How To Clean Stainless Steel".

C. CONTROL KNOBS

To clean the thermostat knob, pull it outward to remove it from the shaft. Wash the knob with mild soap and water, rinse, and dry with a soft cloth. Do not use abrasive cleaners on the plastic surfaces of the knob.

J612, J614 SERIES HOT FOOD COUNTERS

VI. TROUBLESHOOTING

CAUTION: THE FOLLOWING TROUBLE SHOOTING PROCEDURE AND ALL ELECTRICAL REPAIRS SHOULD BE PERFORMED BY A QUALIFIED ELECTRICIAN.

COMPLAINT	POSSIBLE SOLUTION
Hot food well does not heat	<ol style="list-style-type: none"> 1. Check to make sure that there is a proper power supply at the receptacle. Check the unit nameplate for voltage and phase required. 2. Make sure the unit is plugged in properly. 3. Unplug the unit and remove the thermostat control panel cover. 4. Using extreme care, reapply power to the unit and check power coming to the circuit breaker. If 1 and 2 are OK and no voltage is present at the line side of the breaker then, check the electrical connections at the junction box located on the bottom of the unit where the power supply cord connects to the unit. 5. Turn the breaker on and check for power coming out of the circuit breaker. If no voltage is present, the breaker is defective. 6. Check voltage from the breaker to the thermostat. If no voltage is present at the thermostat, check the electrical connections between the breaker and the thermostat. 7. Turn the thermostat on at the defective well and check voltage going from the thermostat to the heating element. If no voltage is present then the thermostat is defective, REPLACE IT. 8. If an amperage reading meter is available check the amperage of the lines going to the heating elements. If no amperage is present but voltage is present, then the element is defective. REPLACE IT. (If an amperage reading meter is not available, remove all power from the unit. Disconnect the heating element leads from the thermostat. Check for continuity through the heating element. If continuity is not present replace the heating element.)
Hot food well unit does not heat properly	<ol style="list-style-type: none"> 1. Check the name plate for the proper voltage for which the unit is designed. Using a suitable instrument, check the voltage being supplied to the unit. The voltage should be within 10% of the unit name plate rating. 2. The thermostats are precalibrated at the factory but may be field adjusted. (See <i>checking calibration page 12</i>)
Heat lamps not heating up (for units with the optional heat lamps)	<ol style="list-style-type: none"> 1. Check the fuses located on the thermostat control panel. Check them with a suitable instrument for continuity. If a fuse is blown, replace with same size and type fuse that was originally supplied. 2. If fuse is OK, remove all power from the unit. Remove the thermostat control panel cover. Check all electrical connections at switches and fuses for loose connections. 3. Using extreme caution reapply power to the unit. Normally power is supplied to the light and heat lamp circuits directly from the primary side of the circuit breaker of the unit. Check power coming from the junction box to the primary side of the breaker. If no power is present, check the connections at the junction box located on the bottom of the unit where the power supply cord connects to the unit.

COMPLAINT	POSSIBLE SOLUTION
Heat lamps not heating up, continued	<ol style="list-style-type: none"> 4. Next check the power from the primary side of the breaker to the fuse holder. If no power is present, check the connection between these two points. 5. Make sure that there is a good fuse in the fuse holder. Check voltage on the outlet pin of the fuse holder. If no voltage is present, the fuse holder may be defective. 6. Check voltage going from the fuse holder to the switch. If no voltage is present, check the connections between the two points. 7. Turn the switch on and check voltage at the switch terminal going to the heat lamp. If no voltage is present switch is defective. REPLACE SWITCH. 8. Turn off all power to the unit. Remove the end cover plate from the heat lamp. Check all electrical connections. 9. If an amperage reading meter is available, check the amperage of the lines going to the heat lamp. If no amperage is present but voltage is present, then the heat lamp housing is defective. (If an amperage reading meter is not available, remove all power from the unit. Disconnect the heat lamp housing leads from the circuit and check for continuity through the heat lamp housing. If no continuity is present replace the heat lamp housing.)
Heat lamp not heating properly (For units with the heat lamp option)	<ol style="list-style-type: none"> 1. Check the name plate rating on heat lamp for the proper voltage for which the unit is designed. Using a suitable instrument, check the voltage being supplied to the unit. The voltage should be within 10% of the unit name plate rating.

VII. SERVICE

In the event service is required on your Aladdin J612 & J614 Series Electric Hot Food Counters, please call:

**ALADDIN SYNERGETICS, INC.,
SERVICE DEPARTMENT
1-800-888-5426**

J612, J614 SERIES HOT FOOD COUNTERS

IX. MAINTENANCE/CALIBRATION

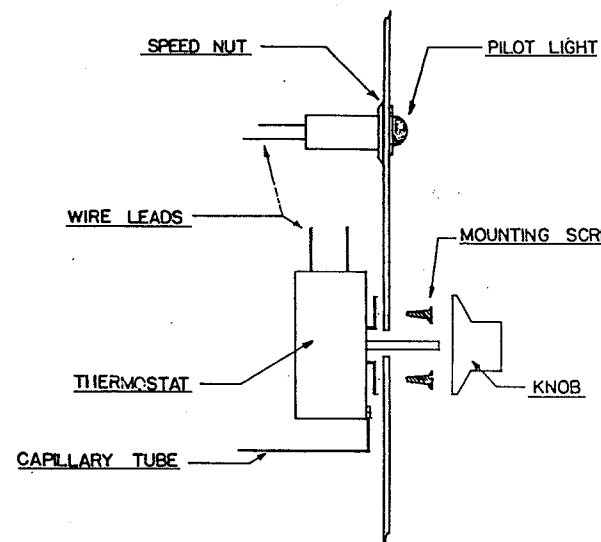

THERMOSTAT & PILOT LIGHT MOUNTING

To remove thermostat

1. Disconnect electricity
2. Remove thermostat mounting panel by removing screws and pulling panel forward
3. Remove wire leads on thermostat
4. Remove the two mounting screws on front of thermostat
5. Remove the four screws in the inspection plate, remove capillary tube

To remove pilot light

1. Disconnect electricity
2. Remove thermostat mounting panel by removing screws and pulling panel forward
3. Remove wire leads on pilot light
4. Remove speed nut on back of pilot light
5. Pull pilot light forward

NOTE: Installation is the reverse of the removal procedure on both the Pilot Light and the Thermostat.

CHECKING CALIBRATION

Each electric thermostat is adjusted at the factory and calibrated on precision instruments to control temperatures accurately. Adjustment or recalibration is not needed unless the thermostat has been mishandled in transit, or changed, or abused while in service.

To Check Calibration

1. Use a potentiometer or a good grade thermometer to determine temperature at location where temperature regulation is required
2. Turn the dial of the thermostat to a medium temperature setting
3. Allow enough time for temperature to stabilize, or until several temperature readings are identical

To Recalibrate

1. Remove dial from shaft "B"
2. Turn screw "A" clockwise to decrease and counter clockwise to increase
3. Replace dial

After calibration is made, let the unit operate until the temperature has stabilized, then recheck to determine whether or not the calibration has been corrected

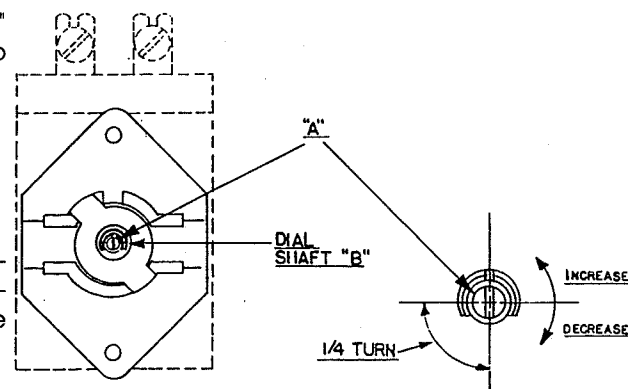

HEATING ELEMENTS MAY BE REMOVED FOR INSPECTION OR REPLACEMENT AS FOLLOWS:

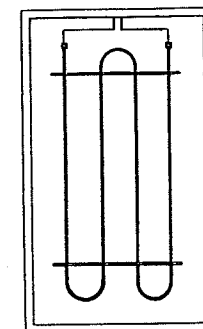

1. Disconnect electricity
2. Remove wires (2) from heater
3. Remove nuts (4) holding reflector pan. (if is not necessary to remove the thermostat bulb)
4. Remove reflector pan and heater
5. Install new heater into the slots of the standoff brackets.
6. Connect the two electric wires to the terminals using the screws in the terminals
7. Replace reflector pan

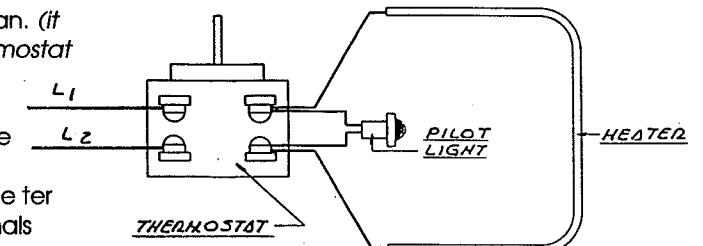

X. DIAGRAMS/DRAWINGS

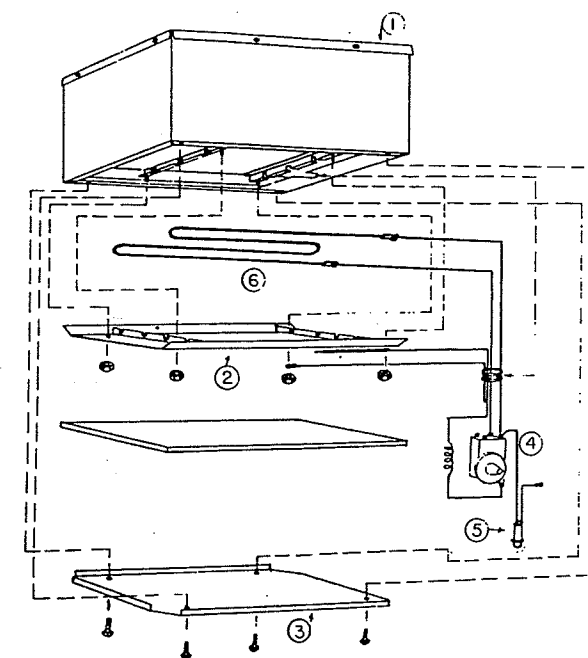
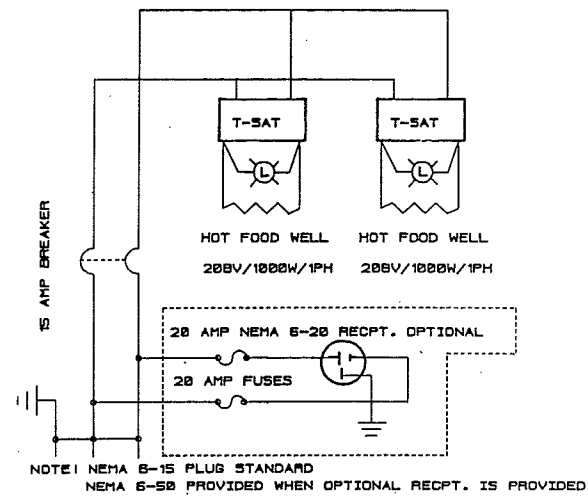

Diagram No.	Description
1	12" x 20" stainless steel well
2	Reflection plate
3	Insulated bottom
4	Thermostat
5	Pilot light
6	1000 watt heating element

J612, J614 SERIES HOT FOOD COUNTERS

X. PARTS LIST



WIRING DIAGRAM MODEL J614

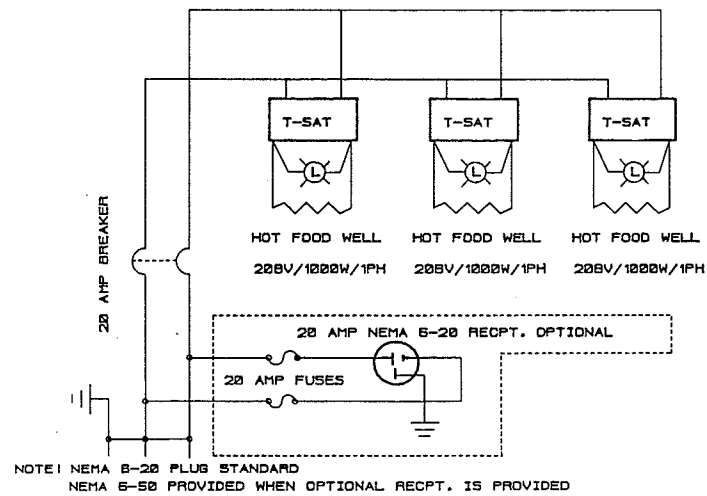

WIRING DIAGRAM MODELS J612 & J614A

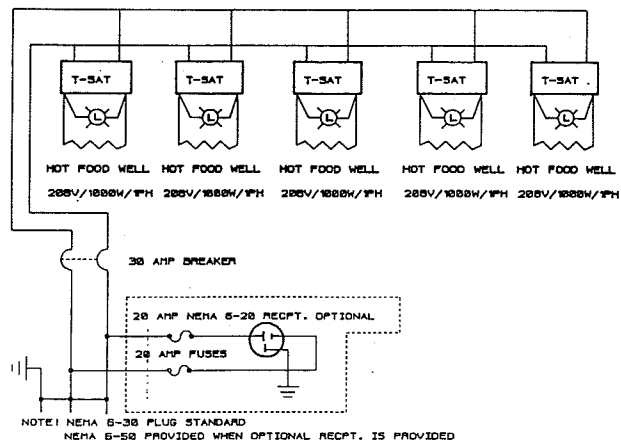

WIRING DIAGRAM MODEL J612B

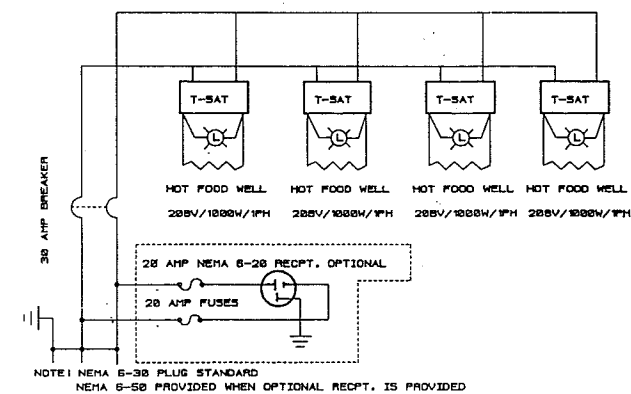

WIRING DIAGRAM MODELS J612A & J614R & J614L

No.	Aladdin Part No.	Stock No.	Item Name	Description
1		N/A	Hot food Well (total assembly)	Model LT- 1008D S.S. well w/ T-stat & Heating Element
2	24856	1950	Heating Element	1000W/208V
3	24855	1954	Thermostat	450 Degree Max. w/Knob
4	24860	3580	Pilot Light	250V / Ruby Red
5		3322	Circuit Breaker	2 Pole 15 AMP (Used on J614)
5A		3322A	Circuit Breaker	2 Pole 20 AMP (Used on J612 & J614A)
5B	39977	3322B	Circuit Breaker	2 Pole 30 AMP (Used on J612A, J612B, J612R, J612L, J614R, J614L)
*6		3404	Receptacle	250V / 20 AMP Single
*7	24859	3582B	Fuse Holders	20A, 600 Volt
*8	39834	5138H	Fuses	20 AMP Type SC Class G
*9		2516	Cord	8/3 SO Cord (Used on J612, J614, J614A)
*9A		2517B	Cord	6/3 SO Cord (Used on J612A, J612B, J612, J614R, J614L)
*10		3452	Plug	250V/50 Amp NEMA6-50P (for models w/ specified outlet)
11		1310	Casters	5" Plate Type Swivel w/ Brakes
12		2370	Drain Valve	3/4" Gate Valve
13		2507	Cord	14/3 Cord (for standard model J614)
14		2510	Cord	12/3 Cord (for standard models J612 & J614A)
15		2515	Cord	10/3 Cord (for standard models J612A, J612B, J614R & J614L)
16		3407A	Plug	250V/15A NEMA 6-15P (for standard J614)
17		3405A	Plug	250V/20A NEMA 6-20P (for standard J614, 612, J614A)
18		3411	Plug	250v/30A NEMA 6-30P (for standard J612A, 612B, J612R & J612L)

NOTES; Heat lamps must be specified individually.

Cord and plug size may change with the addition of heat lamps.

Items marked by (*) are used when electrical receptacle option is specified.

XI. WARRANTY

ALADDIN SYNERGETICS, INC. EQUIPMENT LIMITED WARRANTY

Effective January, 1996

Aladdin Synergetics, Inc. ("Aladdin") warrants to the original purchaser that the equipment listed below shall be free from defects in material and workmanship under normal use for the applicable warranty term set forth below. Aladdin's obligation under this warranty is limited to the repair or replacement, at the sole option of Aladdin, of any part which upon inspection and examination by Aladdin or its authorized agent is found to be defective. A written description detailing the nature of the claimed defect, together with the equipment claimed to be defective if required by Aladdin, must be delivered to Aladdin or its authorized agent within 30 days of discovery of the claimed defect (but in no event later than 30 days after the expiration of the applicable warranty term).

EQUIPMENT	WARRANTY TERM*	
	PARTS	LABOR
J612, J612A, J612B	1 YEAR	90 DAYS
J612L, J612R	1 YEAR	90 DAYS
J614, J614A	1 YEAR	90 DAYS
J614L, J614R	1 YEAR	90 DAYS

*The warranty term commences 30 days after Aladdins invoice for the equipment.

THE WARRANTIES AND REPRESENTATIONS OF ALADDIN CONTAINED HEREIN ARE EXPRESSLY IN LIEU OF, AND THE BUYER WAIVES, ANY AND ALL OTHER WARRANTIES EXPRESS OR IMPLIED, INCLUDING THE WARRANTIES OF MERCHANTABILITY AND FITNESS FOR A PARTICULAR PURPOSE, AND ANY OTHER REMEDIES AGAINST ALADDIN, WHETHER BASED UPON CONTRACT, NEGLIGENCE, STRICT LIABILITY OR OTHERWISE. ALADDIN SHALL NOT BE LIABLE FOR ANY CONSEQUENTIAL OR INCIDENTAL DAMAGES OR ECONOMIC LOSS OF ANY NATURE (INCLUDING WITHOUT LIMITATION LOSS OF REVENUES AND/OR PROFITS) THAT MAY BE CLAIMED TO RESULT FROM ANY NEGLIGENCE OR BREACH OF WARRANTY OR CONTRACT BY ALADDIN.

Exceptions and Exclusions

This warranty is issued only to the original purchaser, and is not transferable and applies only to the products installed within the United States of America, its territories and Canada. During the term of any labor warranty, Aladdin will pay all pre-approved shipping charges incurred in returning defective equipment to Aladdin and labor costs incurred in the removal and reinstallation of such equipment. Contact Aladdin before returning any claimed defective equipment or otherwise performing warranty repairs. Aladdin assumes no liability for any work or repair performed without its prior approval. After the expiration of any labor warranty, the original purchaser is responsible for all shipping charges incurred in returning defective equipment to Aladdin and labor for removing and reinstalling such equipment. Aladdin shall not be responsible for the replacement of expendable items like lamps and fuses or product failure resulting from normal wear and tear, improper installation, misuse, sabotage, abuse, neglect, accident, unauthorized alterations or repair, or other factors beyond the control of Aladdin. Neither this warranty nor the liability of Aladdin may be modified or extended by action of any agent, distributor or other person or by custom or practice.

CALL ALADDIN TOLL FREE AT 1-800-888-5426 IF YOU HAVE ANY QUESTIONS ABOUT THIS WARRANTY OR YOUR ALADDIN PRODUCT.