

# Aladdin Temp-Rite®



P.O. Box 2978, Hendersonville, TN 37077-2978

1-800-888-8018 or 615-537-3600

Fax 1-888-812-9956 [www.aladdintemprite.com](http://www.aladdintemprite.com)

...better by degrees.

## READY 2 DYNE

(REFRIGERATED AUTOMATIC RETHERMALIZER)



R2D2005 (5 Shelf) Shown  
R2D2010 (10 Shelf)

---

---

### INSTALLATION, OPERATION & MAINTENANCE MANUAL

---

---

Manual P/N 94464  
Rev. L 01/08/2013



# READY 2 DYNE QUICK REFERENCE SHEET

## **PROGRAMMING MODE #1: PROGRAMMING MEALS 1-5 (M1-M5)**

To enter Programming Mode, press UP and DOWN at the same time, hold for 3 seconds. Use arrows to scroll from M1 to M5 to select meal to program. Then, follow the steps below to make changes to desired meal(s).

PROMT	DESCRIPTION	RANGE (Default)	DIRECTIONS
EnAbl	Enable/disable meal	Yes/no (no)	<ul style="list-style-type: none"> <li>• Press VIEW.</li> <li>• Press VIEW again, the message will be “no”, press the UP key and “yes” will appear.</li> <li>• Press ENTER</li> </ul>
Htine	Duration of hold state	0-5 hrs in 5 min increments (3 hrs)	<ul style="list-style-type: none"> <li>• Press UP, “HtinE/3:00” will flash.</li> <li>• Press VIEW, “3:00” will appear.</li> <li>• Press the UP or DOWN key until the correct holding time is on the screen.</li> <li>• Press ENTER</li> </ul>
HstPt	Hold state temperature set point	160-210 in 1 degree increments (160)	<ul style="list-style-type: none"> <li>• Press UP, “HstPt/160” will flash.</li> <li>• Press VIEW, 160 will appear.</li> <li>• Press the UP or DOWN key until the correct holding temperature is displayed.</li> <li>• Press ENTER</li> </ul>
rEthd	Retherm duration	5-180 minutes in 5 minutes increments (120)	<ul style="list-style-type: none"> <li>• Press UP key, “rEthd/2:00” will flash.</li> <li>• Press VIEW, “2:00” will appear.</li> <li>• Press the UP or DOWN key to increase or decrease until the correct retherm time is on the screen.</li> <li>• Press ENTER.</li> </ul>
rEtht	Retherm temperature set point	165-230 in 1 degree increments (225)	<ul style="list-style-type: none"> <li>• Press UP key, “rEtht/225” will flash.</li> <li>• Press VIEW, “225” will appear.</li> <li>• Press the UP or DOWN key to increase or decrease until the correct retherm temperature is on the screen.</li> <li>• Press ENTER.</li> </ul>
TinE1	Retherm start time	A12:00-P11:59, in 1 min increments (A9:00)	<ul style="list-style-type: none"> <li>• Press UP key, “TinE1/A9:00” will flash.</li> <li>• Press VIEW, “A9:00” will appear.</li> <li>• Press the UP and DOWN key until the correct retherm start time is on the screen.</li> <li>• Press ENTER.</li> </ul>

**NOTE:** Press ENTER twice (rather than once) to exit programming mode after you make changes to any of the above settings. Press ENTER only once (as directed above in chart) to save and to continue to make changes to other meal setting.

## **PROGRAMMING MODE #2: SETTING TIME OF DAY, CELSIUS/FARHENHEIT, and ALTERING ALARMS**

To enter this programming mode, press VIEW and SHIFT at the same time, hold for 3 seconds. Use UP and DOWN keys to pick which option you want to change (the options/prompts are listed below.)

<b>PROMPT</b>	<b>DESCRIPTION</b>	<b>DIRECTIONS</b>
tod	Time of day	<ul style="list-style-type: none"><li>• “tod/time” will flash, Press VIEW</li><li>• Press the UP and DOWN key to change time (“A” represents AM, “P” represents PM)</li><li>• Press ENTER to set the change.</li><li>• Press ENTER again to exit programming.</li></ul>
C_F	Type of temperature scale (Celsius or Fahrenheit)	<ul style="list-style-type: none"><li>• Press UP key, “ C_F “ will flash, Press VIEW.</li><li>• Press the UP key to change to desired temperature scale (“ C” represents Celsius, “ F” represents Fahrenheit)</li><li>• Press ENTER to set the change.</li><li>• Press ENTER again to exit programming</li></ul>
rSnd	Alarm at end of retherm	<ul style="list-style-type: none"><li>• Press UP key, “rSnd/5” will flash, Press VIEW.</li><li>• Press the UP key to change to desired alarm setting (list is below).</li><li>• Press ENTER to set change.</li><li>• Press ENTER again to exit programming</li></ul>
hSnd	Alarm at end of hold state	<ul style="list-style-type: none"><li>• Press UP key, “hSnd/0” will flash, Press VIEW.</li><li>• Press the UP key to change to desired alarm setting (list is below).</li><li>• Press ENTER to set change.</li><li>• Press ENTER again to exit programming</li></ul>

<b>ALARM SETTING</b>	<b>WHAT IT MEANS</b>
0	No alarm sound
1	Alarm sounded for 2 seconds
2	Alarm sounds off/on every second for 20 seconds
3	3 beeps followed by 1 second off, repeats for 20 seconds
4	Alarm sounds off/on every second continuously
5	Alarm is on solid continuously

---

---

# READY 2 DYNE

---

---

## CONTENTS

I. MODELS .....	6
II. RECEIVING INSPECTIONS .....	8
III. INSTALLATION .....	9
IV. ELECTRICAL .....	10
V. START-UP .....	10
VI. CONTROLLER FACE .....	12
VII. PROGRAMMING THE CONTROLLER .....	13
VIII. CLEANING & MAINTENANCE .....	18
IX. DRAINING & REFILLING THE READY 2 DYNE .....	20
X. WIRING DIAGRAM .....	22
XI. PARTS DIAGRAM & LIST .....	23
XII. SERVICE .....	26
XIII. MATERIAL SAFETY DATA SHEET .....	26
XIV. WARRANTY .....	29

# READY 2 DYNE

## I. MODELS

This conduction unit utilizes cold fluid flowing through hollow shelving, chilling foods until the appropriate pre-programmed time. The cold fluid is then heated and sent back through the shelves, heating foods to HACCP approved serving temperatures. It then enters a holding cycle. The READY 2 DYNE cabinet has an operating temperature range between 34-230°F/1.1-110°C. This unit complies with all HACCP temperature standards regarding refrigeration, rethermalization and holding. Due to the precise temperature control, the food retains moisture, resulting in a higher yield.

<u>MODEL</u>	<u>DESCRIPTION</u>
R2D2010 S	10 Shelf with glass doors

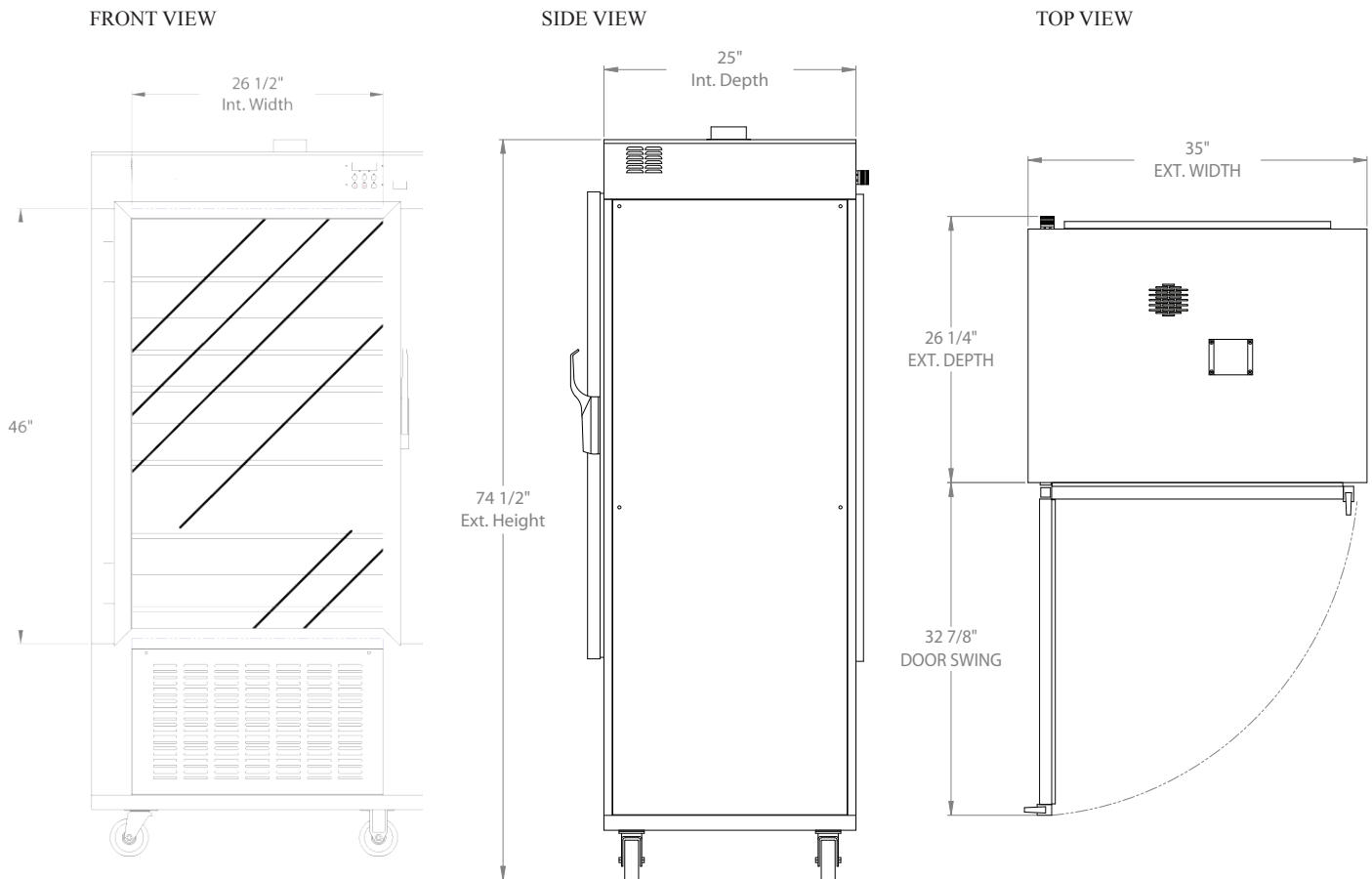

CONTINUED ON NEXT PAGE

MODEL

DESCRIPTION

R2D2005

5 Shelf with glass doors

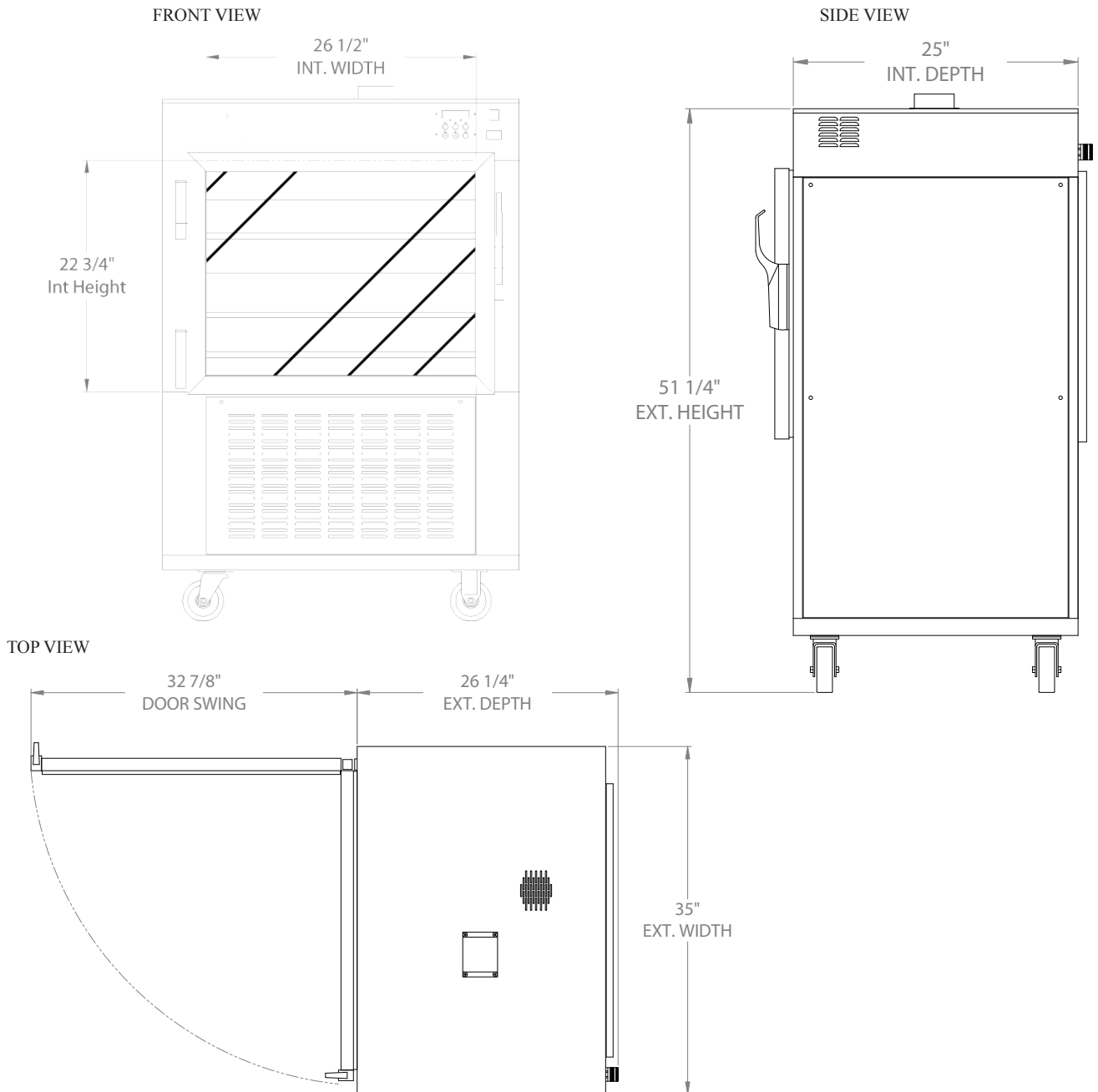

# READY 2 DYNE

## PHYSICAL CHARACTERISTICS/SPECIFICATIONS

Capacity	Model R2D2005 (5 shelf)	Model R2D2010 (10 shelf)
Pan Capacity (per shelf)	2-13.5"x21.5"x2" (full-size) or 4-10.5"x12.5"x2" (half-size)	2-13.5"x21.5"x2" (full-size) or 4-10.5"x12.5"x2" (half-size)
Shelf Capacity	5 shelves to heat 24 lbs/shelf	10 shelves to heat 24 lbs/shelf
Product Capacity	24 lbs/shelf, 120 lbs/unit	24 lbs/shelf, 240 lbs/unit
Heat Transfer Fluid	2.2 gal (8.3 l)	3.9 gal (14.8 l)
Dimensions		
Exterior Dimensions	(WxDxH) 35" (88.9cm) x 26.25" (66.7cm) x 51.25" (130.2 cm)	(WxDxH) 35" (88.9cm) x 26.25" (66.7cm) x 74.5" (189.2 cm)
Interior Dimensions	(WxDxH) 26.5" (67.3 cm) x 25" (63.5 cm) x 22.25" (56.5 cm)	(WxDxH) 26.5" (67.3 cm) x 25" (63.5 cm) x 44.5" (113.0 cm)
Max. operating temp	230°F/110°C	230°F/110°C
Min. operating temp	34°F/1.1°C	34°F/1.1°C
Net Weight	429 lbs (195 kg)	564 lbs (256 kg)
Gross shipping weight	633 lbs (287 kg)	794 lbs (360 kg)
Shipping Cube	64.5 cu. ft. (1.8 cu. m)	91.67 cu. ft. (2.6 cu. m)
Electrical		
Volts	208-240, 50/60 Hz, 1 ph	208-240, 50/60 Hz, 1 ph
Amps	26 amps	53 amps
Watts	5250 (@ 208v)	10,500 (@ 208v)
Breaker required	30 amp	60 amp
Plug Type	NEMA L14-30P, 30 amp 250 Volt	NEMA 14-60P, 60 amp 250 Volt
Electrical Cord	10/4 SO, Length 10' (3.04m)	6/4 SO, Length 10' (3.04m)

## OPTIONAL ACCESSORIES

Push Handles

Bumpers

Heat Transfer Fluid

Temperature Data Logger

## II. RECEIVING INSPECTIONS

### NOTE:

All Aladdin® units are factory tested for performance and certified free from defects.

### ALADDIN DAMAGED GOODS POLICY

There are two types of damaged merchandise:

- Visual Damage
- Concealed Damage

Visual Damage – When the product being received is visibly damaged.

1. Receiver should not accept merchandise with visual damage.
2. Receiver must sign delivery receipt "refused merchandise due to damage" and specify damage.
3. Receiver should call Aladdin Customer Service immediately after refusal.
4. Carrier will notify Aladdin Traffic Department and a claim will be filed.
5. Carrier will send acknowledgement of claim within 7 days after receiving.

Concealed Damage – When damaged merchandise cannot be externally detected.

Any receiving operation should be looking for this type of damage. Sometimes, however, depending on the type of product, it is almost impossible to notice.

1. Merchandise must not be removed from point of delivery and all packaging must be kept intact.
2. Receiver must contact Aladdin customer service to report damage.
3. Aladdin traffic department will request inspection based on the dollar value of the cargo.
4. Aladdin traffic department will file a claim based on the findings of the inspection.

Failure to comply with these policies will result in the customer's responsibility to file claims.

## III. INSTALLATION

Removing unit from packaging material

### **Caution Glass Doors**

1. Cut and remove metal banding from box exterior. This will release any attachment of the box to the pallet.
2. Lift and remove cardboard box. Box does not have a bottom and is easily removed by lifting up.
3. Cut and remove metal banding used to secure unit to pallet. This will release any attachment the unit has to the pallet.
4. Visually check unit for damage per Receiving Inspection

CONTINUED on next page

*FRONT VIEW OF CRATE*

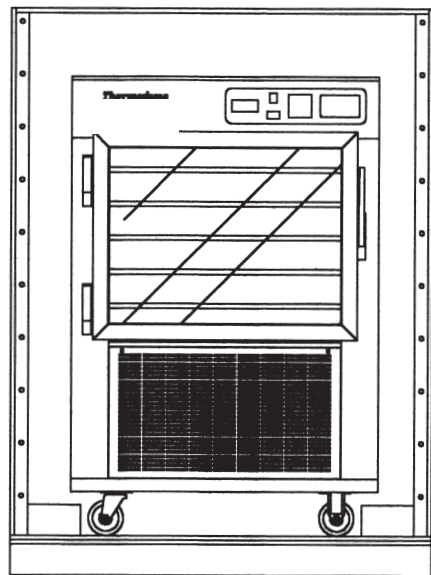

*SIDE VIEW OF CRATE*

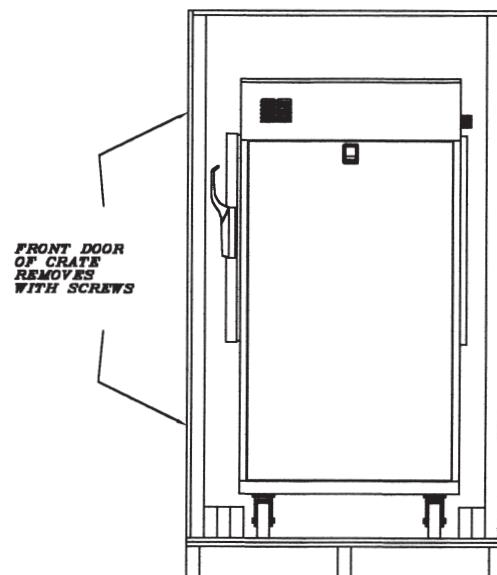

---

---

# READY 2 DYNE

---

---

5. After the crate has been opened the oven can now be removed. Using two people roll the oven to the front of the crate. If a fork lift is available slide the forks under the oven and remove it from the crate and place it on the ground. The oven can now be rolled to its destination. (If a fork lift is not available adequate manpower can lift it from the crate and place it on the floor. **CAUTION** the oven weighs 400 lbs.
6. Check packing list against items received:
  - Heat Transfer Fluid (1 gallon extra fluid located in the space under oven and above pallet)
  - Operations Manual
  - 32oz Fill Bottle
7. Remove plastic covering from oven glass door frames and hinges.
8. Set oven on a level floor.
9. Plug in oven, let sit for 24 hours before putting power switch to the on position.
10. Check all connections for leaking and make sure the fans in the interior of the walls function during the cooling cycle.
11. The Set Point Temperature will be reached in approximately 30 minutes.

NOTE: Refer to Add Fluid light only when oven is cold. If Add Fluid light remains lit after oven has reached operating temperature, refer to V. START-UP section of this manual below.

## IV. ELECTRICAL

---

Electrical	Model R2D2005 (5 shelf)	Model R2D2010 (10 shelf)
Volts	208-240, 50/60 Hz, 1 ph	208-240, 50/60 Hz, 1 ph
Amps	26 amps	53 amps
Watts	5250 (@ 208v)	10,500 (@ 208v)
Breaker required	30 amp	60 amp
Plug Type	NEMA L14-30P, 30 amp 250 Volt*	NEMA 14-60P, 60 amp 250 Volt*
Electrical Cord	10/4 SO, Length 10' (3.04m)	6/4 SO, Length 10' (3.04m)

\*Plugs are 4-wires with ground, 2 hot and neutral

## V. START-UP

---

1. Check to be sure all items have been removed from the unit.
2. Put power switch into "ON" position.
3. Check fluid indicator light.  If light remains on or flickers continuously after fifteen minutes, add Heat Transfer Fluid. Aladdin recommends that the heat transfer fluid be added to a cold unit (below 45°F). If the Oven is overfilled, fluid will escape from the vapor relief valve when the oven heats up. DO NOT TRY TO REMOVE CAP IF TEMPERATURE OF OVEN IS ABOVE 200 DEGREES FAHRENHEIT. HOT FLUID COULD OVERFLOW AND CAUSE BURNS.

CONTINUED ON NEXT PAGE

FLUID REPLENISHMENT:

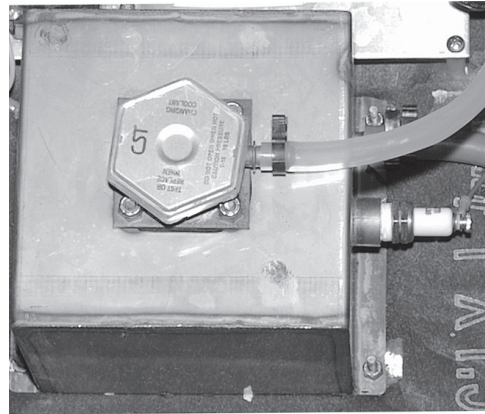

To add fluid, turn the unit off, unplug the unit, remove the top cover (four screws to be removed with a Phillips head screwdriver), and locate the fill cap on top of the fluid tank on the right hand side. This cap is similar to an automotive radiator cap. Unscrew the fill cap. Using the fill bottle of heat transfer fluid provided, pour transfer fluid into the fluid tank just until the “Add Fluid” light goes off or when the level is 1" from the top. After filling, be sure to screw the fill cap firmly back into place. Replace the top, securely refasten screws, plug the unit into receptacle and turn red power switch to the on position.

***IMPORTANT-*** Add fluid only when oven is cold! - With oven temperature between 34° F. and 45° F.

NOTE: AFTER FILLING, BE SURE TO SCREW CAP FIRMLY BACK INTO PLACE.

NOTE: IF THE FLUID INDICATOR LIGHT REMAINS ON AFTER THE UNIT HAS BEEN FILLED, CONTACT THE ALADDIN SERVICE DEPARTMENT.

4. The controller readout will light up and indicate the temperature of the fluid in the tank (not the food temperature) at present time. Cooling temperatures will be between 34°F and 41°F. Heating cycles will have a maximum temperature of 230°F. Holding cycles temperatures can be set between the range of 160-210°F.
5. The operating temperature will be reached in approximately 30 minutes. This time will vary as the beginning fluid temperature and operating temperature are varied.
6. To turn the oven off turn the red power switch to the off position.

# READY 2 DYNE

## VI. CONTROLLER FACE

### A. NAME OF

#### 1. VIEW key

- Press once for time of day.
- Press twice to view the time Left in a heating cycle or the amount of time it has been in a hold cycle.
- Press three time to view the next programmed mealtime

#### 2. ENTER Key

- Used to enter, or confirm, the conclusion of changes to a mealtime setting.

#### 3. UP Key (MANUAL CHILL when used with SHIFT)

- Used to increase, or scroll through the values that can be set when programming the Controller.

#### 4. SHIFT key

- Used in conjunction with the "UP/MANUAL CHILL" key. ONLY while the unit is in the hold cycle, pressing SHIFT and MANUAL CHILL simultaneously will return the unit to the manual chill mode.

#### 5. EXIT / SILENCE Key

- Used to exit programming without changing previous settings.
- Used to silence an audible alarm.

#### 6. DOWN Key

- Used to decrease settings, or scroll through values when programming the controller.

#### 7. Manual Chill Cycle

- Pressing the "UP/MANUAL CHILL" key and the "SHIFT" key at the same time and while the unit is in a hold cycle will revert the unit to its chill cycle.

#### 8. Menu Program Password

- Simultaneously pressing "UP" & "DOWN" keys for 3 seconds sends the controller into the programming menu where Enable, Retherm duration, Retherm Temperature, Hold time, Hold temperatures & Meal Times can be set.

#### 9. Secondary Program Password

- Simultaneously pressing the "VIEW" key and the "SHIFT" for 3 seconds allows the unit to be programmed with time of day and other parameters.

#### 10. Displays The Temperature

- The display shows the fluid temperature that circulates through the oven

#### 11. Heat indicator LED

- When LED is solidly lit - Retherm Cycle, when flashing - Hold Cycle.

#### 12. Chill indicator LED

- When LED is solidly lit - Chill Mode.

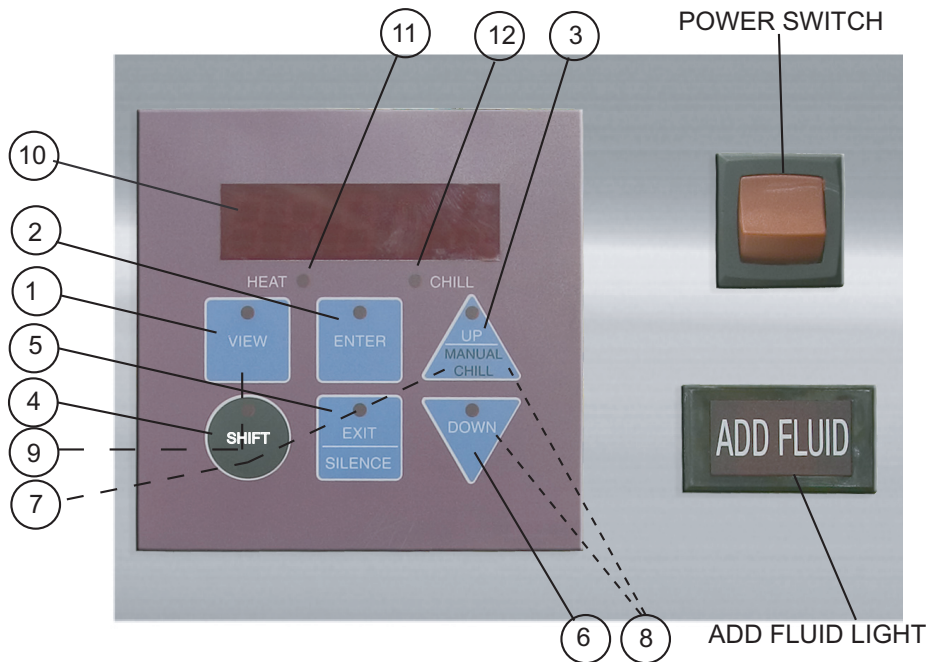

---

---

## VII. PROGRAMMING THE CONTROLLER

---

### SETTING THE TIME OF DAY

1. Turn the Red Power Switch to “ON”
2. To view the “Time Of Day” - Press the “VIEW” button for 1-2 seconds.
3. Setting the Time Of Day
  - Press the “VIEW” & “SHIFT” keys simultaneously for 3 seconds.
  - The display will flash “tod” and the time, alternately.
  - Press “VIEW” again and the time will be displayed, but not flashing.
  - Press the “UP” or “DOWN” keys to change the time. Scroll to the correct time. (A represents AM; P represents PM.)
  - Once the time is correct, press the “ENTER” key to set the time.
  - Press “ENTER” again to confirm and leave this programming stage.\*\*  
DO NOT PRESS the EXIT key as this will make the time revert to the previous setting before it was changed.

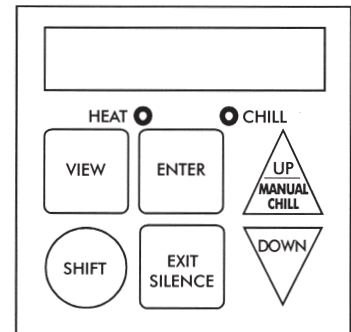

- \*\* Like the “tod” parameter, users may wish to change the settings for the temperature scale, “°C\_°F”; the end of retherm alarm, “r Snd”; or the end of hold alarm “H Snd” at this point by scrolling with the arrow keys to the parameter prior to pressing “Enter” for the second time.

The alarms have 6 settings, 0 through 5. This is what the alarm settings mean:

- 0 = no alarm sound
- 1 = alarm sounded for 2 seconds
- 2 = alarm sound alternatives on/off every second for 20 seconds
- 3 = 3 short beeps follow by 1 second off, this cycle repeats itself for 20 seconds.
- 4 = alarm sounds on/off every second continuously
- 5 = alarm is on solid, continuously

“r Snd” signals the end of retherm, and its default value is 5. “H Snd” indicates the end of the hold cycle, and its default value is 0.

The following is the procedure that should be followed when programming the controller. The controller programming allows six functions for each meal to be entered into the system.

# READY 2 DYNE

They are:

Prompt	Description		Values
EnAbl	Enable/Disable menu number.	Range:	Yes, No
		Default:	No
TinEl	Retherm Start Time	Range:	A12:00, P11:59, set in 1 min increments
		Default:	A09:00
rEtht	Retherm Temperature Setpoint	Range:	165 to 230°F, in 1°F increments
		Default:	225°F
rEthd	Retherm Duration	Range:	5 to 180 min, in 5 min increments
		Default:	120 min.
HStPt	Hold State temperature setpoint	Range:	160-210°F, in 1°F increments
		Default:	160°F
Htine	Duration of Hold State	Range:	0 to 5 hrs, in 5 min increments
		Default:	3 hrs.

When entering programming for the first time, each meal 1-5 [(M1), (M2), (M3), (M4), (M5)] will have the factory defaults entered for each parameter. All Enable settings will be No, all holding times will be 3:00 hours, all holding temperatures will be 160°F, all retherming durations will be 2:00 hours, all retherming temperatures will be 225°F and all meal retherm times will be A-9:00 (9am).

To Enter Programming:

1. Press the “UP” & “DOWN” and hold for 3 seconds until the “M1” characters appear. (Use the arrows to scroll from M1 to M5.) *Keep in mind that if no programming keys are pressed for one minute, the controller will automatically exit to the normal operating mode.*

To enable a meal, set a hold time duration, set a hold temperature, set a retherm duration, set a retherm temperature and set a meal time, follow the following instructions:

## ENABLE A MEAL

2. Press “VIEW.” the screen will display - EnAbl / no - these two words will flash from EnAbl to no appearing alternately on the screen. (no is the factory preset).
3. Press “VIEW” again and the message will be - no.
4. Press the “UP” key then yES will appear.
5. Press “ENTER” the screen will display - EnAbl / yES - alternately flashing. (a meal has been enabled).

TO CONTINUE THROUGH THE PROGRAMMING SCREENS PRESS THE “UP” KEY. THE NEXT OPTION IS HOLDING TIME. - (Proceed to Step 7)

6. To confirm and leave the programming for Meal 1 (M1) stage, Press “ENTER” “ENTER” - (ENTER 2 TIMES).

CONTINUED ON NEXT PAGE

SET HOLDING TIME - Holding time range 0 min to 3 hours

7. Press "UP" the screen will display - HtinE / 3:00 - alternately flashing (HtinE - 3:00 = holding time 3 hours).
8. Press "VIEW" and the 3:00 will appear. (To change the time to 2hr 40 min {for example} proceed with steps 9 & 10.)

IF THREE HOURS IS DESIRED AND NO CHANGES ARE NECESSARY, PRESS ENTER AND PROCEED TO THE NEXT SCREEN WHICH IS HOLDING TEMPERATURE).

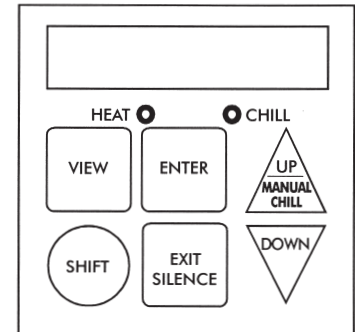

9. Press the "DOWN" key 4 times and 2:40 will appear. (The key changes in 5 minute increments ranging from 0 min to 3 hours).
10. Press "ENTER" and the screen will display - HtinE / 2:40 - alternately flashing (indicating that the new holding time has been entered).

TO CONTINUE THROUGH THE PROGRAMMING SCREENS PRESS THE "UP" KEY THE NEXT OPTION IS HOLDING TEMPERATURE. (Proceed to Step 12)

11. To confirm and leave the programming for Meal 1 (M1) stage. Press "ENTER" "ENTER" - (ENTER 2 TIMES).

SET HOLDING TEMPERATURE - Holding temperature range 160° to 210°F

12. Press "UP" and the screen will display - HstPt / 160 - alternately flashing (HstPt - 160 = holding temp 160° F).
13. Press "VIEW" and 160° can now be changed. (The key changes the temperature in 1 degree increments ranging from 160° - 210° F.)
14. To change the temperature to 185° (for example) - Press the "UP" key 25 times and now the holding temp has been changed to 185°.
15. Press "ENTER" and the screen will display HstPt / 185 alternately flashing. (indicating that the new holding temperature has been entered.)

TO CONTINUE THROUGH THE PROGRAMMING SCREENS PRESS THE "UP" KEY THE NEXT OPTION IS RETHERM HEATING DURATION. (Proceed to Step 17)

16. To confirm and leave the programming for Meal 1 (M1) stage. Press "ENTER" "ENTER" - (ENTER 2 TIMES).

---

---

# READY 2 DYNE

---

---

## SET RETHERM HEATING DURATION – Retherm time range 5 min to 3 hours

17. Press “UP” the screen will display - rEthd / 2:00 - alternately flashing. (rEthd - 2:00 = holding time 2 hours).
18. Press “VIEW” and the 2:00 will appear. (To change the time to 2hr 10 min {for example} proceed with steps 19 & 20.)  
IF TWO HOURS IS DESIRED AND NO CHANGES ARE NECESSARY,  
PRESS ENTER AND PROCEED TO THE NEXT SCREEN WHICH IS RETHERM TEMPERATURE.
19. Press the “UP” key 2 times and 2:10 will appear. (The key changes in 5-minute increments ranging from 5 min to 3 hours).
20. Press “ENTER” and the screen will display - rEthd / 2:10 - alternately flashing (indicating that the new retherm time has been entered).

TO CONTINUE THROUGH THE PROGRAMMING SCREENS PRESS THE “UP” KEY THE NEXT OPTION IS RETHERM TEMPERATURE. (Proceed to Step 22)

21. To confirm and leave the programming for Meal 1 (M1) stage. Press “ENTER” “ENTER” - (ENTER 2 TIMES).

## SET RETHERM TEMPERATURE - Retherm temperature range 165° to 230°F

22. Press “UP” and the screen will display - rEtht / 225 - alternately flashing. (rEtht - 225 = retherm temp 225° F).
23. Press “VIEW” and 225° can now be changed. (The key changes the temperature in 1-degree increments ranging from 165° - 230° F.)
24. To change the temperature to 200° (for example) - Press the “DOWN” key 25 times and now the retherm temp has been changed to 200°.
25. Press “ENTER” and the screen will display rEtht / 200 alternately flashing (indicating that the new retherm temperature has been entered).

TO CONTINUE THROUGH THE PROGRAMMING SCREENS PRESS THE “UP” KEY THE NEXT OPTION IS MEAL RETHERM TIME. (Proceed to Step 27)

26. To confirm and leave the programming for Meal 1 (M1) stage. Press “ENTER” “ENTER” - (ENTER 2 TIMES).

CONTINUED ON NEXT PAGE

---

---

SET MEAL RETHERM TIME- tine 1

27. Press "UP" and the screen will display - tinE 1 / A 9:00 - alternately flashing. (tinE 1 - A 9:00 = retherm time 9am/tinE - P 9:00 = retherm time 9 pm).
28. Press "VIEW" and the A 9:00 will appear. (To change the time to 7am {for example} proceed with the following steps.)
29. Press "DOWN" key and hold until A 7:00 appears. (The key changes in 1-minute increments).
30. Press "ENTER" and the screen will display - tinE / A 7:00 - alternately flashing (indicating that the retherm time has been entered)

ALL PARAMETERS FOR MEAL 1 (M1) HAVE BEEN SET AT THIS POINT. BY CONTINUING THE PROCESS, ALL 5 MEALS (M1, M2, M3, M4, & M5) CAN BE SET FOLLOWING THE PROCEDURE OUTLINED ABOVE.

Press the "UP" (MANUAL CHILL) key and the "SHIFT" key (black circle) simultaneously.

EXITING PROGRAMMING AND SETTING THE TIMES AND TEMPERATURES JUST ENTERED.

31. Press "ENTER" and Press "ENTER" again.

NOTE: If "EXIT" is pressed it will void all the information that was just entered into the controller and default back to the previously set information.

NOTE: If ErtM (error time) is displayed when programming retherm times, an overlapping retherm time has been scheduled. Go back and check for the overlap, because the overlap will not permit those overlapped times to heat.

NOTE: When HOLD times and RETHERM times overlap from a previously set start time, the RETHERM time will take precedence and will not give an error message.

NOTE: If any other messages occur, call Aladdin Temp-Rite Service Department at 1-(800) 888-5426 for assistance as to their meaning.

TO CEASE ANY HOLDING CYCLE AND TO RETURN TO THE CHILL MODE:

Press the "UP"(MANUAL CHILL) key and the "SHIFT" key (black circle) simultaneously.

---

---

# READY 2 DYNE

---

---

## VIII. CLEANING & MAINTENANCE

---

**CAUTION:** To prevent injury, before cleaning, always be sure oven is unplugged from the electrical source and has had sufficient time to cool.

### A. HOW TO CLEAN STAINLESS STEEL

#### 1. WHEN TO CLEAN

It is recommended that all stainless steel equipment be cleaned on a regular basis. Any piece of stainless steel equipment that is soiled should be cleaned daily to ensure the long life of the equipment. Routine cleaning will lessen stainless steel abrasion.

#### 2. HOW TO CLEAN

To remove most soil, use a nonabrasive, non-chlorinated soap solution. Rinse thoroughly with warm water and wipe dry using an absorbent cloth. **TO REMOVE HEAVY SOIL, RUB THE AREA WITH A NON-METALLIC, FINE GRAIN SCOURING CLOTH.** Be sure to rub in the same direction as the metal grain. Rinse thoroughly with warm water and wipe using a soft absorbent cloth. As a final step, a stainless steel polish may be used only on the exterior. The polish will shine the stainless steel and provide a protective finish that will reduce future soiling.

#### 3. CLEANING SAFEGUARDS

Always rub with the metal grain. **NEVER USE STEEL WOOL OR METALLIC SCOURING CLOTHS.** This will help prevent scratching and possible damage to the surface finish.

Use recommended dilution. Do not exceed concentration levels which may cause long term deterioration of surface. Be certain to rinse thoroughly to prevent buildup of cleanser.

**NEVER USE CHLORINE OR BLEACH SOLUTIONS.** Check the ingredients of cleaning solutions or disinfectants used as they may contain chlorinated solvents. Always read the label of the cleaning solutions. Check for warnings about use on stainless steel or aluminum products. Repeated use of chlorinated solvents may cause a chemical reaction with stainless steel and aluminum, which will damage the surface and cause rusting.

#### 4. STERILIZING STAINLESS STEEL

When sterilizing stainless steel equipment, pay particular attention to agents containing chlorine compounds such as potassium hypochlorite. These compounds may break down and release free chlorine or hydrolyze to form hydrochloric acid. Stainless steel resists attack by the compounds for up to two hours. Severe localized pitting may occur with longer exposure. For safe use of the agents, keep contact time short, flush thoroughly with water, and operate equipment normally between applications. Using these precautions, the sterilization process can be repeated any number of times.

CONTINUED ON NEXT PAGE

---

---

## SPECIFIC INSTRUCTIONS FOR CLEANING THE COMPONENTS OF THE READY 2 DYNE OVEN

The Ready 2 Dyne operates on the principle of conduction, rather than convection; it is very important to keep the heat transfer shelves clean so that the heat transfer may take place with maximum efficiency. It is also very important to keep the BOTTOMS (contact surfaces) of your pots and pans as clean as possible to ensure even and complete heat transfer.

The surface and flat coating of the thermal heat transfer shelf is extremely hard, but it will react with strong caustic cleaning solutions and be eaten away. MOST CONCENTRATED SOAPS AND AMMONIA CLEANERS ARE TOO CAUSTIC TO BE USED ON THE READY 2 DYNE. If the coating is destroyed, the heat transfer shelves will lose their nonstick properties and also their surface hardness.

### 1. CLEANING THE HEAT TRANSFER PLATES

The cleaners should always be used at the recommended concentrations and in the case of dry powders, the powders must not be placed directly on the surface of the thermal plate. Care must be taken when using brushes or pads not to scratch the shelf surfaces. If harsh scouring is needed, use a scouring pad. Any nylon type pads are acceptable for scouring. Never use steel wool.

It is recommended that a weekly cleaning schedule is followed to avoid the buildup of heavy food deposits. In the event that heavy deposits occur that are difficult to remove with ordinary cleaning procedures, stronger chemical cleaning agents may be applied if the product is intended for food service use and is also compatible with hard coat anodized aluminum surfaces. When using these stronger solvents it is very important that the thermal plates are rinsed thoroughly with clean, potable water. After cleaning, be sure to remove all traces of the cleaning agent. Between the regularly scheduled cleaning, wipe off the anodized aluminum surfaces periodically with a clean, damp cloth.

### 2. STAINLESS STEEL CABINET

- A. For occasional thorough cleaning, the door should be removed by first opening fully and then lifting up and away from unit. Be sure to place the door after removal in a secure place to prevent damage.
- B. Any pot and pan detergent acceptable for food service cleaning and compatible with aluminum and stainless steel may be used on shelf and cabinet surfaces.
- C. A 20" plastic bristled brush used with the appropriate detergent is acceptable for cleaning. It is very important when cleaning the heat transfer shelves that the undersides of the shelves are thoroughly cleaned also.
- D. Hot water hose rinsing is preferred. Rinse with a sponge or cloth and clear hot water. Be sure all surfaces are completely rinsed.

---

---

# READY 2 DYNE

---

---

- E. The glass door can be cleaned with any commercial window cleaning product providing that they are ammonia & chlorine free and food service compatible.
- F. If door removal was done for maintenance or thorough cleaning. Check that the door fits securely on the hinges and open and close freely.

### 3. HEAT TRANSFER FLUID MAINTENANCE

The Aladdin Heat Transfer Fluid should be flushed and refilled with fresh transfer fluid on an annual basis. transfer fluid if necessary. Aladdin Heat Transfer Fluid has lubricating additives, anti-corrosion additives, and heat transfer properties that may decrease with the passing of time. Heat Transfer Fluid will protect your oven almost indefinitely if the fluid is changed a regular basis.

## IX. DRAINING & REFILLING THE READY 2 DYNE

---

### CHANGING THE HEAT TRANSFER FLUID

**Important:** To be performed by a Qualified Facility Technician.

- A. Disconnect the oven from its power source and allow the unit to cool completely. (*Preferably overnight*)
- B. Remove the stainless steel panel covering the left side of the Ready 2 Dyne.
- C. Locate the drain plugs at the end of the shelf fluid supply rail, (see figure A).
- D. Place a pan underneath the oven to catch the spent fluid. (Be prepared to collect 5 gals. of fluid). See Material Safety Data Sheet for proper disposal. (page 25)

Before opening drain plug:

- 1. Remove locking pressure cap from reservoir tank on top of oven, (see figure B)
- 2. Be sure to have a funnel with a drain hose attached to it.
- 3. Loosen drain plug with wrench while holding funnel below it.

CONTINUED ON NEXT PAGE

E. Remove the drain plugs all the way and allow the fluid to completely drain.

**Caution!** Even after cooling, the fluid may still be hot!

F. After the oven has drained, ***replace the drain plugs.***

G. Refill the oven with new Aladdin Heat Transfer Fluid.

**IMPORTANT:** Do Not Substitute water or any other liquid in your oven since the "Aladdin Heat Transfer Fluid" is formulated to prevent corrosion and protect against freezing and boiling.

Figure A  
Drain Plug

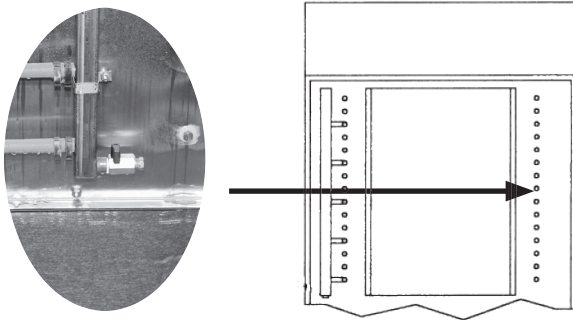
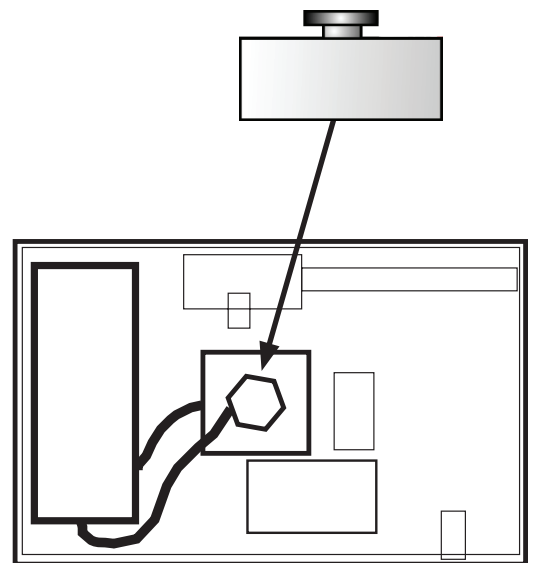

Figure B  
Pressure Cap



# READY 2 DYNE

## X. WIRING DIAGRAM

208-240 V / 1Ph

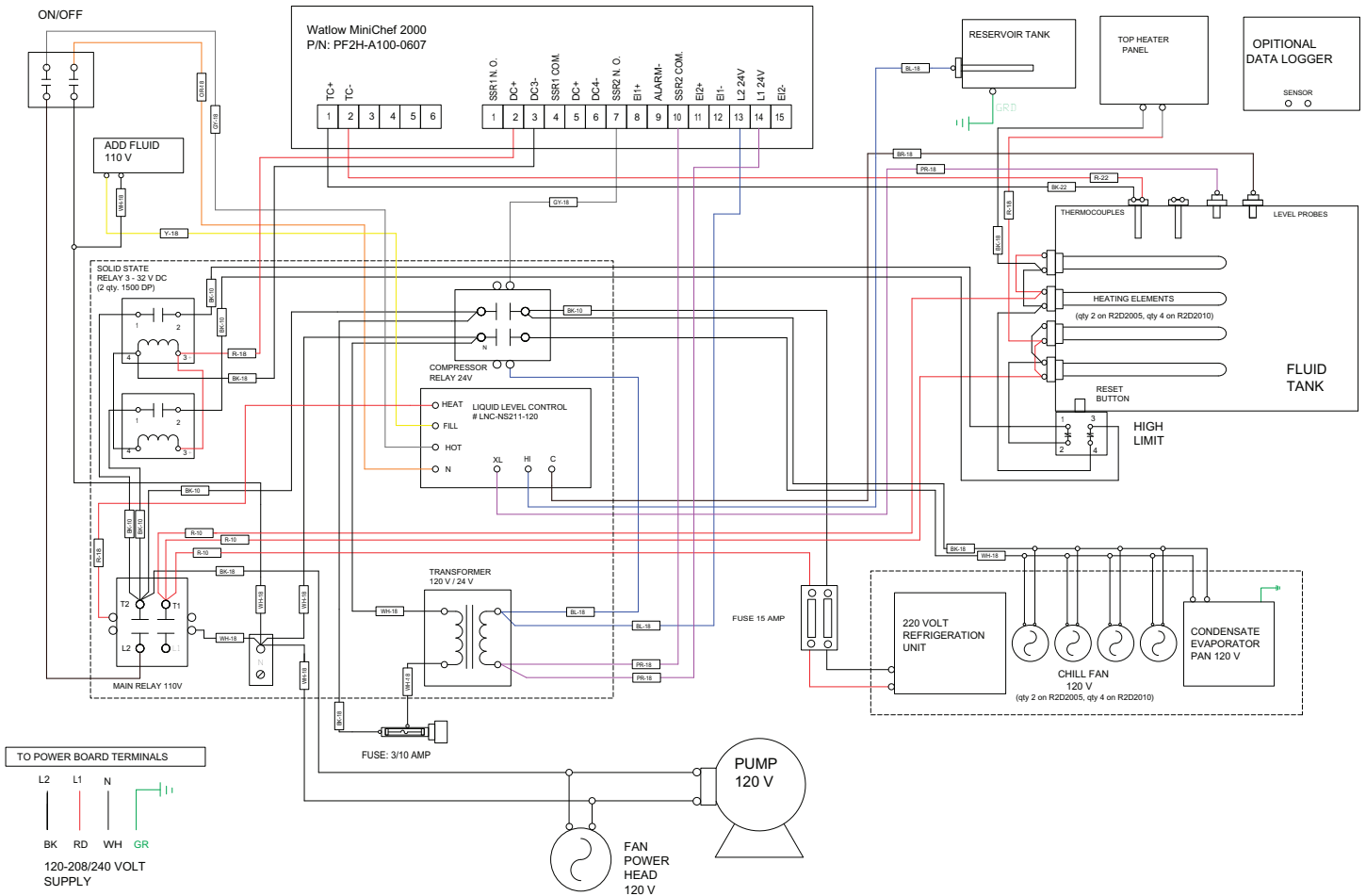

# XI. PARTS DIAGRAM

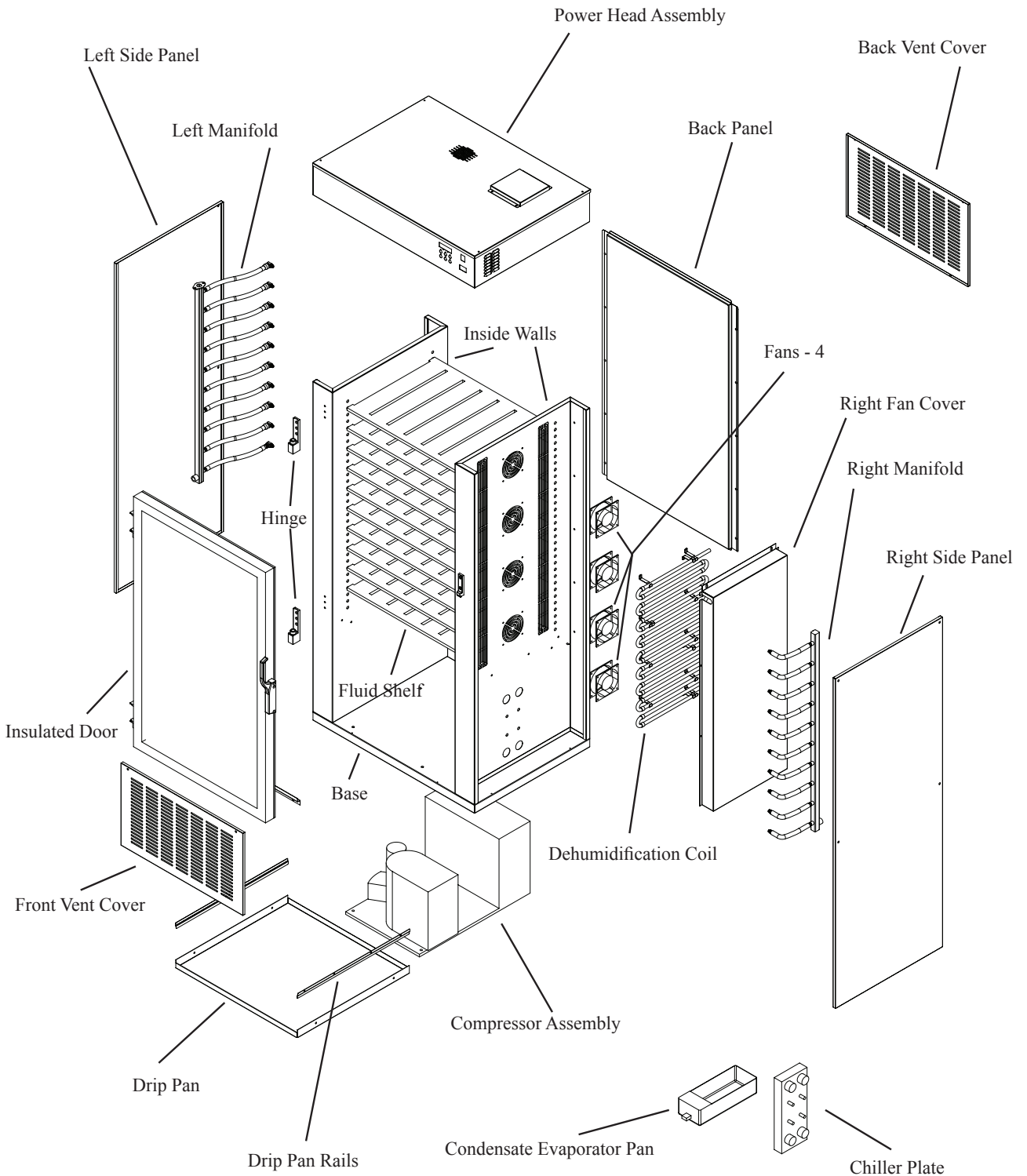

# READY 2 DYNE

## POWER HEAD PARTS LIST

Item	ATR Part No.	Description
1	96417	Heater tank, 5-shelf unit
	96418	Heater tank, 10-shelf unit
2	96420	Thermocouple, type-J, for datalogger
3	96420	Thermocouple, type-J, for main control
4	96421	Ground probe fluid level
5	96421	Extra-low fluid level probe
6	98224	Fluid pump - 120v
6a	99876	tank to pump fitting (for units before 2007, containing Laing pumps)
6b	99875	pump to line fitting (for units before 2007, containing Laing pumps)
7	96421	Reservoir fluid level probe
8	96419	Pressure cap
9	96413	Overflow tube
10	96414	Reservoir tank
11	96415	Power cord, 5-shelf
	96416	Power cord, 10-shelf
12	96398	Main Power Contactor, 3pole/40amp/120v coil
13	98341	Cooling fan - 120v
14	96399	First solid-state relay for heater, dc input x 90amp rating
15	94016	Controller
16	96399	Second solid-state relay for heater, dc input x 90 amp rating (10-shelf only)
17	96397	Compressor contactor, 2pole/30amp/24v coil
18	96409	Fluid level board - 120v
19	96408	Transformer Primary - 120v, secondary 24v
20	96401	High limit switch
21	96407	Heater
22	96411	Siphon tube
<b>On the face - not seen in this view</b>		
LT	96402	"Add fluid" light - 110v
SW	96403	Rocker switch
<b>Additional items</b>		
	96404	Plug,NEMA 14-60, 10-shelf
	96405	Plug,NEMA 6-30, 5-shelf
	96406	Top panel heater
	34925	1 Gallon heat Transfer Fluid
	92361	5 Gallon heat Transfer Fluid
	97889	Heater shelf
	98099	Door handle & catch
	98100	Door hinge
	98342	Compressor cooling fan 240volt
	98343	power head cooling fan 120volt

# POWER HEAD PARTS DIAGRAM

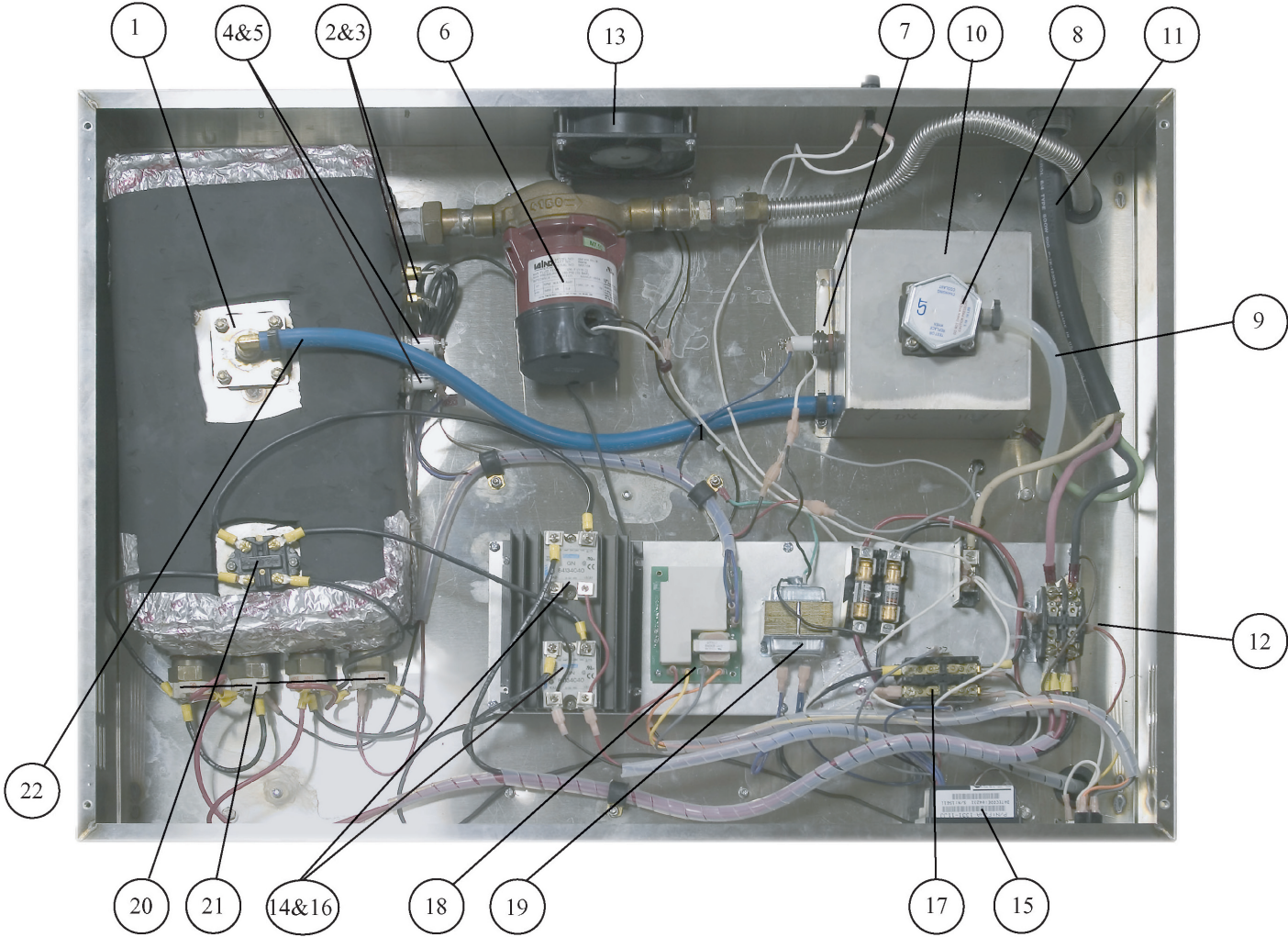

---

---

# READY 2 DYNE

---

---

## XII. SERVICE

---

In the event service is required on your Aladdin READY 2 DYNE refrigerated automatic rethermalizer please call:

ALADDIN TEMP-RITE  
SERVICE DEPARTMENT  
1-800-888-5426

## XIII. MATERIAL SAFETY DATA SHEET

---

1. VAN WATERS & ROGERS INC., A ROYAL PAKHOED COMPANY  
6100 CARILLON POINT, KIRKLAND WA, 98033 (425) 889-3400

.....EMERGENCY ASSISTANCE.....

EMERGENCY ASSISTANCE INVOLVING CHEMICALS CALL:  
CHEMTREC Emergency Phone: 1-(800) 424-9300

Product Name: PROPYLENE GLYCOL USP

Effective Date: 09-16-96 Date Printed: 09/16/96  
MSDS #: D270531

2. COMPOSITION / INFORMATION ON INGREDIENTS:

Propylene glycol CAS# 000057-55-6 99%

3. HAZARDS IDENTIFICATION EMERGENCY OVERVIEW

Colorless liquid, odorless. Toxic fumes are released in fire situations.

POTENTIAL HEALTH EFFECTS  
(See Section 11 for toxicological data.)

EYE: May cause slight transient eye irritation. Corneal injury is unlikely.  
Mists may cause eye irritation.

SKIN: Prolonged contact is essentially nonirritating to skin. A single prolonged exposure is not likely to result in the material being absorbed through skin in harmful amounts. Repeated exposures may cause flaking and softening of skin. May be absorbed in potentially harmful amounts when applied in large quantities to severe burns (second or third degree) over large areas of the body as part of a cream or other topical application. absorption under such circumstances can elevate serum osmolality and may result in osmotic shock.

INGESTION: Single dose toxicity is considered to be extremely low. No hazards anticipated from swallowing small amounts incidental to normal handling operations.

INHALATION: At room temperature, vapors are minimal due to physical properties. Mists may cause irritation of upper respiratory tract.

SYSTEMIC (OTHER TARGET ORGAN) EFFECTS: Repeated excessive ingestion may cause central nervous system effects.

CANCER INFORMATION: Did not cause cancer in long term animal studies.

TERATOLOGY (BIRTH DEFECTS): Birth defects are unlikely. Exposures having no adverse effects on the mother should have no effect on the fetus.

REPRODUCTIVE EFFECTS: In animal studies, has been shown not to interfere with reproduction.

#### 4. FIRST AID

EYE: Flush eyes with plenty of water.

SKIN: Wash off in flowing water or shower.

INGESTION: No adverse effects anticipated by this route of exposure incidental to proper industrial handling.

INHALATION: Remove to fresh air if effects occur. Consult a physician.

NOTE TO PHYSICIAN: No specific antidote. Supportive care. Treatment based on judgement of the physician in response to reactions of the patient.

#### 5. FIRE FIGHTING MEASURES

##### FLAMMABLE PROPERTIES:

FLASH POINT: 218F, 103C

METHOD USED: PMCC

AUTOIGNITION TEMPERATURE: Not determined

##### FLAMMABLE LIMITS

LFL: 2.6% @ 100C

UFL: 12.5% @ 130C

HAZARDOUS COMBUSTION PRODUCTS: During a fire, smoke may contain the original material in addition to unidentified toxic and/or irritating compounds. Hazardous combustion products may include and are not limited to: aldehydes, carbon monoxide.

OTHER FLAMMABILITY INFORMATION: Violent steam generation or eruption may occur upon application of direct water stream to hot liquids. Spills of these organic liquids on hot fibrous insulations may lead to lowering of the autoignition temperatures possibly resulting in spontaneous combustion.

EXTINGUISHING MEDIA: Water fog, or fine spray, Carbon dioxide. Dry chemical. Foam. Alcohol resistant foams (ATC type) are preferred if available. General purpose synthetic foams (including AFFF) or protein foams may function, but much less effectively. Do not use direct water stream. Will spread fire.

MEDIA TO BE AVOIDED: Do not use direct water stream.

FIRE-FIGHTING INSTRUCTIONS: Keep people away. Isolate fire area and deny unnecessary entry. Burning liquids may be moved by flushing with water to protect personnel and minimize property damage. Burning liquids may be extinguished by dilution with water. Do not use direct water stream. May spread fire.

PROTECTIVE EQUIPMENT FOR FIRE FIGHTERS: Wear positive-pressure self-contained breathing apparatus (SCBA) and protective fire fighting clothing (includes fire fighting helmet, coat, pants, boots and gloves). If protective equipment is not available or not used, fight fire from a protected location or safe distance.

#### 6. ACCIDENTAL RELEASE MEASURES (See Section 15 for Regulatory Information)

PROTECT PEOPLE: Isolate area.

PROTECT THE ENVIRONMENT: Contain liquid to prevent contamination of soil, surface water or ground water.

CLEANUP: For small spills, clean up with absorbent material. Collect material in suitable and properly labeled open containers. For large spills, dike and pump into suitable and properly labeled containers.

#### 7. HANDLING AND STORAGE

HANDLING: Product handled hot may require additional ventilation or local exhaust.

STORAGE: Keep containers tightly closed when not in use. Store in stainless steel, aluminum, plastic 3066 lined containers, or 316 stainless steel.

#### 8. EXPOSURE CONTROLS/PERSONAL PROTECTION

ENGINEERING CONTROLS: Provide general and/or local exhaust ventilation to control airborne levels below the exposure guidelines.

##### PERSONAL PROTECTIVE EQUIPMENT

EYE/FACE PROTECTION: Use safety glasses. Safety glasses should be sufficient for most operations; however, for misty operations wear chemical goggles.

SKIN PROTECTION: Use gloves impervious to this material.

RESPIRATORY PROTECTION: Atmospheric levels should be maintained below the exposure guideline. When respiratory protection is required for certain operations, use an approved air-purifying respirator. In misty atmospheres, use an approved mist respirator.

##### EXPOSURE GUIDELINE (S):

Propylene glycol: AIHA WEEL is 50 ppm total, 10 mg/m<sup>3</sup> aerosol only.

#### 9. PHYSICAL AND CHEMICAL PROPERTIES

APPEARANCE: Colorless liquid

ODOR: Odorless

VAPOR PRESSURE: 0.08 mmHg. @ 20°C, 68 °F

VAPOR DENSITY: 2.62

BOILING POINT: 370 °F, 188 °C

SOLUBILITY IN WATER: Complete

SPECIFIC GRAVITY: 1.038 20/20 °C, 68 °F

#### 10. STABILITY AND REACTIVITY

CHEMICAL STABILITY: Stable

CONDITIONS TO AVOID: Product can decompose at elevated temperatures.

INCOMPATIBILITY WITH OTHER MATERIALS: Avoid contact with oxidizing materials.

HAZARDOUS POLYMERIZATION: Will not occur.

CONTINUED ON NEXT PAGE

---

# READY 2 DYNE

---

11. TOXICOLOGICAL INFORMATION (See Section 3 for Potential Health Effects. For detailed toxicological data, write or call the address or non emergency number shown in section 1)

SKIN: The LD50 for skin absorption in rabbits is >10,000 mg/kg.

MUTAGENICITY: In vitro mutagenicity studies were negative. Animal mutagenicity studies were negative.

12. ECOLOGICAL INFORMATION (For detailed Ecological data, write or call the address or non-emergency number shown in Section 1)

## ENVIRONMENTAL FATE

MOVEMENT AND PARTITIONING: Based largely or completely on information for similar material (s), i.e. propylene glycol. Bioconcentration potential is low (BCF less than 100 or Log Pow less than 3). Log octanol/water partition coefficient (log Pow) is -0.92. Henry's Law Constant (H) is 1.2E-8 atm. m<sup>3</sup>/mole.

DEGRADATION & PERSISTENCE: Based largely or completely on information for similar material (s), i.e. propylene glycol. Biodegradation under aerobic static laboratory conditions is high (BOD20 or BOD28/ThOD greater than 40%). Biodegradation is expected to be achievable in a secondary waste water treatment plant. 5-Day biochemical oxygen demand (BOD5) is 1.16 p/p. 20-Day biochemical oxygen demand (BOD20) is 1.45 p/p. Theoretical oxygen demand (ThOD) is calculated to be 1.68 p/p. Inhibitory concentration (IC50) in OECD Activated Sludge Respiration Inhibition Test (OECD test No. 209) is greater than 1 gm/L. Degradation is expected in the atmospheric environment within minutes to hours.

ECOTOXICITY: Based largely or completely on information for similar material (s), i.e. propylene glycol. Material is practically non-toxic to aquatic organisms on an acute basis (LC50 greater than 100 mg/L in most sensitive species). Acute LC50 for fathead minnow (*Pimephales promelas*) is 4600-54900 mg/L. Acute LC50 for guppy (*Poecilia reticulata*) is greater than 10000 mg/L. Acute LC50 for water flea (*Daphnia magna*) is 4850-34400 mg/L. Acute LC50 for rainbow trout (*Oncorhynchus mykiss*) is 44 mL/L (about 44000 mg/L).

13. DISPOSAL CONSIDERATIONS: (See section 15 for Regulatory Information)

DISPOSAL: DO NOT DUMP INTO ANY SEWERS, ON THE GROUND, OR INTO ANY BODY OF WATER. All disposal methods must be in compliance with all Federal, State/Provincial and local laws and regulations. Regulations may vary in different locations. Waste characterizations and compliance with applicable laws are the responsibility solely of the waste generator. THE VENDOR HAS NO CONTROL OVER THE MANAGEMENT PRACTICES OR MANUFACTURING PROCESSES OF PARTIES HANDLING OR USING THIS MATERIAL. THE INFORMATION PRESENTED HERE PERTAINS ONLY TO THE PRODUCT AS SHIPPED IN ITS INTENDED CONDITION AS DESCRIBED IN MSDS SECTION 2 (Composition/Information On Ingredients).

## 14. TRANSPORT INFORMATION

DEPARTMENT OF TRANSPORTATION: This product is not regulated by D.O.T. when shipped domestically by land.

CANADIAN TDG INFORMATION: For TDG regulatory information, if required, consult transportation regulations, product shipping papers, or your DOW representative.

15. REGULATORY INFORMATION (Not meant to be all-inclusive--selected regulations represented)

NOTICE: The information herein is presented in good faith and believed to be accurate as of the effective date shown above. However, no warranty, express or implied is given. Regulatory requirements are subject to change and may differ from one location to another; it is the buyer's responsibility to ensure that its activities comply with federal, state or provincial, and local laws. The following specific information is made for the purpose of complying with numerous federal, state or provincial, and local laws and regulations. See other sections for health and safety information.

SARA 313 INFORMATION: To the best of our knowledge, this product contains no chemical subject to SARA Title III Section 313 supplier notification requirements.

SARA HAZARD CATEGORY: This product has been reviewed according to the EPA "Hazard Categories" promulgated under sections 311 and 312 of the Superfund Amendment and Reauthorization Act of 1986 (SARA Title III) and is considered, under applicable definitions, to meet the following categories:

Not to have met any hazard category

TOXIC SUBSTANCES CONTROL ACT (TSCA): All ingredients are on the TSCA inventory or are not required to be listed on the TSCA inventory.

STATE RIGHT-TO-KNOW: This product is not known to contain any substances subject to the disclosure requirements of: New Jersey, Pennsylvania.

OSHA HAZARD COMMUNICATION STANDARD: This product is not a "Hazardous Chemical" as defined by the OSHA Hazard Communications Standard, 29 CFR 1910, 1200.

## CANADIAN REGULATIONS

WHMIS INFORMATION: The Canadian Workplace Hazardous Materials Information System (WHMIS) Classification for this product is:

This product is not a "Controlled Product" under WHMIS.

## 16. OTHER INFORMATION

MSDS STATUS: Revised to 16 Section format.

## FOR ADDITIONAL INFORMATION

CONTACT MSDS COORDINATOR VAN WATERS & ROGERS INC.  
DURING BUSINESS HOURS, PACIFIC TIME (425) 889-3400

PRODUCT: 610366 CUST NO: 367668 ORDER NO.159806

## NOTICE

"VAN WATERS & ROGERS INC. (VW&R), AROYAL PAKHOED COMPANY, EXPRESSLY DISCLAIMS ALL EXPRESS OR IMPLIED WARRANTIES OF MERCHANTABILITY AND FITNESS FOR A PARTICULAR PURPOSE, WITH RESPECT TO THE PRODUCT OR INFORMATION PROVIDED HEREIN, AND SHALL UNDER NO CIRCUMSTANCES BE LIABLE FOR INCIDENTAL OR CONSEQUENTIAL DAMAGES"

---

---

# XIV. WARRANTY

---

## ALADDIN TEMP-RITE EQUIPMENT LIMITED WARRANTY

Effective November 1, 2000

\*The warranty term commences 30 days after Aladdin's invoice for the equipment.

Aladdin Temp-Rite ("ATR") warrants to the original purchaser that the equipment listed below shall be free from defects in material and workmanship under normal use for the applicable warranty term set forth below. ATR's obligation under this warranty is limited to the repair or replacement, at the sole option of ATR, of any part which upon inspection and examination by ATR or its authorized agent is found to be defective. A written description detailing the nature of the claimed defect, together with the equipment claimed to be defective if required by ATR, must be delivered to ATR or its authorized agent within 30 days of discovery of the claimed defect (but in no event later than 30 days after the expiration of the applicable warranty term).

EQUIPMENT	WARRANTY TERM*	
	PARTS	LABOR
R2D2005, R2D2005C, R2D2010, R2D2010C	1 Year	90 Days

\*The warranty term commences 30 days after Aladdin's invoice for the equipment.

THE WARRANTIES AND REPRESENTATIONS OF ATR CONTAINED HEREIN ARE EXPRESSLY IN LIEU OF, AND THE BUYER WAIVES, ANY AND ALL OTHER WARRANTIES EXPRESS OR IMPLIED, INCLUDING THE WARRANTIES OF MERCHANTABILITY AND FITNESS FOR A PARTICULAR PURPOSE, AND ANY OTHER REMEDIES AGAINST ATR, WHETHER BASED UPON CONTRACT, NEGLIGENCE, STRICT LIABILITY OR OTHERWISE. ATR SHALL NOT BE LIABLE FOR ANY CONSEQUENTIAL OR INCIDENTAL DAMAGES OR ECONOMIC LOSS OF ANY NATURE (INCLUDING WITHOUT LIMITATION LOSS OF REVENUES AND/OR PROFITS) THAT MAY BE CLAIMED TO RESULT FROM ANY NEGLIGENCE OR BREACH OF WARRANTY OR CONTRACT BY ATR.

### Exceptions and Exclusions

This warranty is issued only to the original purchaser, and is not transferable and applies only to the products installed within the United States of America, its territories and Canada. During the term of any labor warranty, ATR will pay all pre-approved shipping charges incurred in returning defective equipment to ATR and labor costs incurred in the removal and reinstallation of such equipment. Contact ATR before returning any claimed defective equipment or otherwise performing warranty repairs. ATR assumes no liability for any work or repair performed without its prior approval. After the expiration of any labor warranty, the original purchaser is responsible for all shipping charges incurred in returning defective equipment to ATR and labor for removing and reinstalling such equipment. ATR shall not be responsible for the replacement of expendable items like lamps and fuses or product failure resulting from normal wear and tear, improper installation, misuse, sabotage, abuse, neglect, accident, unauthorized alterations or repair, or other factors beyond the control of ATR. Neither this warranty nor the liability of ATR may be modified or extended by action of any agent, distributor or other person or by custom or practice.

CALL ALADDIN TOLL FREE AT 1-800-888-5426 IF YOU HAVE ANY QUESTIONS ABOUT THIS WARRANTY OR YOUR ATR PRODUCT.







250 East Main Street, Hendersonville, TN 37075

1-800-888-8018 • [www.aladdintemprite.com](http://www.aladdintemprite.com) • [info@aladdin-atr.com](mailto:info@aladdin-atr.com)