

# OPERATOR MANUAL/USER GUIDE

IMPORTANT INFORMATION, KEEP FOR OPERATOR

This manual provides information for:

## **MODEL SYSTEM II**

### **MEAL DELIVERY SYSTEM**

- Hot Side, flexible to cold foods
- Cold Side
- Conduction heating with adjustable heat intensities
- Available Capacity: 20 trays



**THIS MANUAL MUST BE RETAINED FOR FUTURE REFERENCE. READ, UNDERSTAND AND FOLLOW THE INSTRUCTIONS AND WARNINGS CONTAINED IN THIS MANUAL.**

#### **NOTIFY CARRIER OF DAMAGE AT ONCE**

It is the responsibility of the consignee to inspect the container upon receipt of same and to determine the possibility of any damage, including concealed damage. Unified Brands suggests that if you are suspicious of damage to make a notation on the delivery receipt. It will be the responsibility of the consignee to file a claim with the carrier. We recommend that you do so at once.

Manufacture Service/Questions 888-994-7636.

Information contained in this document is known to be current and accurate at the time of printing/creation. Unified Brands recommends referencing our product line websites, [unifiedbrands.net](http://unifiedbrands.net), for the most updated product information and specifications.

PART NUMBER SYSII REV A (08/11)

The logo for "à la cart" featuring a stylized white 'c' with a dot inside, followed by the text "à la cart" in a serif font with a trademark symbol.

The logo for "unified brands" featuring three interlocking circles to the left of the text "unified brands" in a sans-serif font with a trademark symbol.

**A DOVER COMPANY**

**1055 Mendell Davis Drive**  
**Jackson, MS 39272**  
**888-994-7636, fax 888-864-7636**  
**[unifiedbrands.net](http://unifiedbrands.net)**

# Table of Contents

## **SECTION 1: Product Information**

Product Description .....	page 3
Components & Accessories .....	page 3-5
System II Cart Specification Sheet .....	page 6-7
System II Controller/Chiller Specification Sheet .....	page 8-9

## **SECTION 2: Overview & Operating Instructions**

Menu Planning .....	page 10
Plating Guidelines .....	page 10-11
Plating Principles & Diagrams .....	page 11-16
Tray Presentation/Placement of Dishware .....	page 17
Tray Presentation Diagrams .....	page 18-20
Display Panel Instructions .....	page 21-26
• Overview of Display Panel .....	page 21
• Normal Chiller Operation and Sequence of Events .....	page 22
• Using Manual Retherm & Hold Cycles .....	page 23
• Using “Options” Menu for Programming, Reading Error Log, & Setting Password .....	page 24-26
Instructional Postings .....	page 27-32
• Cart Loader Checklist .....	page 27
• Dock Cart to Chiller .....	page 28
• Undock Cart from Chiller .....	page 29
• Cart Cleaning .....	page 30
• Dishware Care – China .....	page 31
• Dishware Care – Plastic .....	page 32
Cleaning Agents .....	page 33

## **SECTION 3: Troubleshooting Guide**

Faults & Errors .....	page 34-35
Maintenance Log .....	page 36

# Product Information



## PRODUCT DESCRIPTION

System II Retherm Cart PN 98000-1; Controller/Chiller PN 98004-1

- System II uniquely uses a **conduction** heating method for rethermalizing hot foods. The intensity of the conduction heating is adjustable, unlike any other conduction retherm system on the market.
- Food is plated cold and completed trays are placed inside the retherm cart and docked to a controller/chiller unit to hold foods in a refrigerated state, until an automatic or manual retherm cycle is started.
- Conduction heaters are used for the entrée, and soup or hot side dish that can be adjusted for heat intensity, in an approximate 38 minute heating cycle.
- Chilled air circulates throughout the entire cart, and the cart is thermostatically controlled at 36° - 39° F. during the chill, retherm, and hold modes to keep cold foods cold.
- The tray is 14" x 18" and is constructed with a ridge near the center that horizontally divides the hot side from the cold side. The retherm cart holds 20 trays.
- Standard `A la Cart dishware is used on the hot side of the tray; any type or brand of dishware can be used on the cold side of the tray in addition to or in place of `A la Cart dishware.
- System II utilizes advanced retherm technology and programming features, whereby the heater intensity per meal can be customized, a self-diagnostic check of heaters and refrigeration is conducted with each use, and a security password can be set, as outlined in the System II Display Panel Instructions found in Section 2.
- System II is ready to use with the optional `A la Cart Central Management Control System (CMCS).

## COMPONENTS & ACCESSORIES

ITEM	PART NO.	ITEM DESCRIPTION
System II Cart	98000-1	51.25" H x 21.5" W x 41.375" L
System II Controller/Chiller	98004-1	Holds 20 trays
Menu Minder Card	91144-1	60.7" H x 26" W x 24" D
Central Management Control System (CMCS)	97603-1	Requires 208 VAC, 3 ph., 5 wire; 30 amp

# Product Information

## COMPONENTS & ACCESSORIES Continued







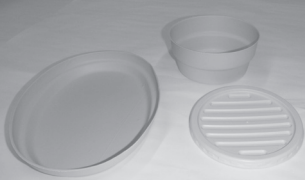

*Items can be purchased separately. All dishware and trays come with a standard 90-day warranty except where noted.*

IMAGE	PART NO.	ITEM DESCRIPTION	NO. PER CASE
<b>CHINA TABLEWARE</b>			
	90682-2	Entrée Plate, oval, 8 3/8"L, 6 1/2"W, 7/8"H	36
	90687-2	Entrée Dish Cradle, dark gray plastic	36
	90689-2	Insulated Entrée Cover, oval, tinted polysulphone, 9"L x 6 1/2"W x 2"H, 2 1/2" food clearance (polysulphone, 1-year warranty)	48
	90658-2	Insulated Entrée Cover, oval, clear, 6 1/2"W x 2"H, 2 1/2" food clearance (polycarbonate, 90-day warranty)	48
	90684-2	Soup Bowl, 10 oz., 4 11/16" diameter, 1 7/8"H, 1 5/8" inner wall height, white	24
	90688-2	Soup Bowl Cradle, dark gray plastic	24
	90662-3	Soup Bowl Lid, opaque, disposable	1K
	90662-4	Soup Bowl Lid, high heat, disposable	2K
	90685-2	Bread Plate, 5 1/4" diameter, 13/16"H	48
	90686-2	Dessert Cup, 4 11/16" diameter, 15/16"H	48
<b>PLASTIC TABLEWARE</b>			
	90682-1	Entrée Dish, rectangular, divided, 8 1/2"L x 6"W, 1 3/8"H	45
	90689-3	Insulated Entrée Cover, tinted (polysulphone, 1year warranty)	48
	90658-3	Insulated Entrée Cover, clear (polycarbonate, 90-day warranty)	48
	90658-1	Non-insulated Entrée Cover, tinted, 8 7/8"L x 6 3/8"W x 1 7/8"H, 2 1/2" food clearance	70
	90684-1	Soup Bowl, 10 oz., 5 1/2" L x 4"W x 1 7/8"H, inner wall height 1 3/8"	56
	90662-1	Soup Bowl Lid, clear, disposable	500

# Product Information

## COMPONENTS & ACCESSORIES Continued

*Items can be purchased separately. All dishware and trays come with a standard 90-day warranty except where noted.*

IMAGE	PART NO.	ITEM DESCRIPTION	NO. PER CASE
<b>PLASTIC TABLEWARE CONTINUED</b>			
	90683-1	Side Dish, 5 1/2"H x 4"W x 1 3/8"H, inner wall height 15/16"	80
	90659-1	Side Dish Cover, 6 15/16"L x 4 7/16"W x 1 7/8"H, 2 1/2" food clearance	56
<b>DISPOSABLE DISHWARE</b>			
	90811-1	Entrée Dish, 9" oval, white (requires Entrée Plate Cradle and Entrée Cover listed under China Tableware)	500
	90812-1	Soup Bowl, 10 oz. round, white (requires Soup Bowl Cradle listed under China Tableware)	500
	90662-4	Soup Bowl Lid, disposable, high heat	2K
<b>TRAYS</b>			
	90709-5	Grey Tray, 14" x 18"	20
	90709-7	Speckled Almond Tray, 14" x 18"	20
<b>TRAY MATS</b>			
	90664-1	Moon Rise Tray Mat, fits 14" x 18" tray	1K
	90666-1	Flower Tray Mat, fits 14" x 18" tray	1K
	90667-1	Southwestern Tray Mat, fits 14" x 18" tray	1K
	90668-1	Patriotic Tray Mat, fits 14" x 18" tray	1K
	90669-1	Fall Tray Mat, fits 14" x 18" tray	1K
	90665-2	Season's Greetings Tray Mat, fits 14" x 18" tray	1K

## System II Cart model 98000-1

### Model Numbers

20-Tray Model 98000-1

### Description

The System II Cart is both a meal storage unit (prior to rethermalization) and a meal delivery and tray retrieval unit. The design offers the optimum in operational simplicity and reliability.

### Specifications

**CABINET EXTERIOR:** High-impact molded polyethylene and stainless steel construction.

**CABINET BASE/INTERIOR:** The cabinet interior and base are formed, welded and riveted stainless steel.

**DOORS:** Two stainless steel and molded polyethylene doors; swing 270 degrees; held open via magnets.

**MOBILITY:** 4 swivel casters; 2 locking and 2 nonlocking.

**REFRIGERATION SYSTEM:** Cooling provided by a cold air supply from a companion Controller Chiller Unit. Refrigerant is R404.

**HEATING:** Individual conduction heaters slide between the tray surface and the underside of the dishware. Rethermalization controlled by the processor in the Controller Chiller Unit.

**ELECTRICAL:** Plugs into Controller Chiller Unit and receives all commands and heating power from that unit.

### Standard Features

- Narrow width for all standard door openings
- Cold rethermalizing environment – trays and covers remain cool to the touch
- “Gentle” heating during rethermalization – preserves food quality

### Dimensions (WxLxH)

- 21.5” x 41.375” x 51.25 ”
- Weight: 231 lbs

### Accessories - Dishware

- 90682-2 Oval China Entrée Dish
- 90658-2 China Entrée Cover
- 90687-2 Cradle Oval China Entree
- 90689-2 China Insulated Entrée Cover
- 90682-1 Plastic Entrée Dish
- 90658-3 Plastic Entrée Cover
- 90689-3 Plastic Insulated Entrée Cover



### Accessories - Dishware Continued

- 90684-1 Plastic Soup Bowl
- 90684-2 China Soup Bowl
- 90688-2 Cradle China Soup Bowl
- 90685-2 China Dessert Cup
- 90686-2 China Bread Plate
- 90662-3 China Soup Bowl Lid
- 90662-1 Plastic Soup Bowl Lid
- 90664-1 Moonrise Tray Mat
- 90665-2 Seasons Greetings Tray Mat
- 90666-1 Flower Tray Mat
- 90667-1 Southwestern Tray Mat
- 90668-1 Patriotic Tray Mat
- 90669-1 Fall Tray Mat
- 90709-5 Gray Tray
- 90709-7 Speckled Almond Tray
- 90811-1 Disposable Entrée Dish
- 90812-1 Disposable Soup Bowl

### Accessories - Support Equipment

- G101099 Enclosed Tray Transport Cart
- 98003-1 A la Cart Transport Cart
- 207304 Open Rack for 32 Trays
- BR229004 Mobile Basket Rack
- DC501-5-480 Side Dish Cart
- DC501-7-240 Entree Dish Cart
- 95008-1 Tray Storage Rack
- 97603-1 CMCS

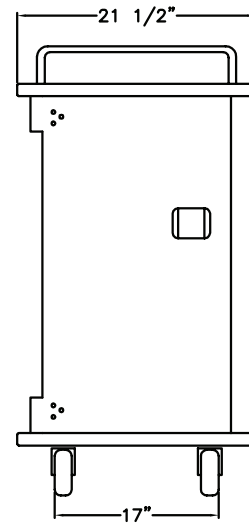
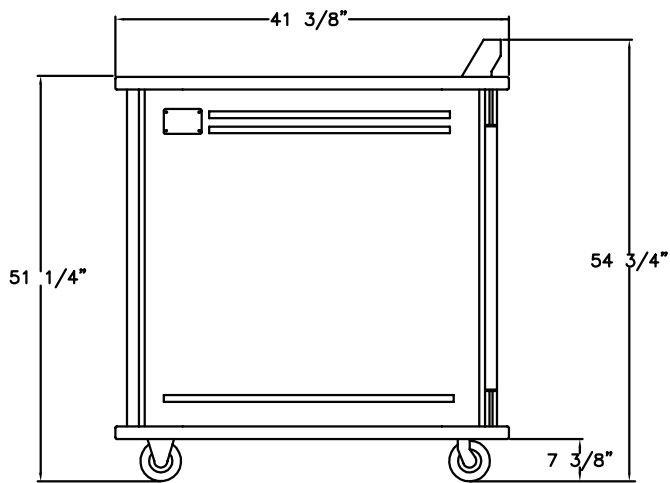
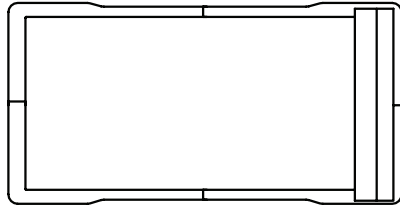

## System II Controller/Chiller model 98004-1

### Model Numbers

Model 98004-1

### Description

The A la Cart Controller/Chiller is the companion unit to the System II Cart. It is typically located in the pantry on the patient floor of a hospital, and in a central kitchen or any other location dedicated for storage and holding of loaded carts before delivery to the patient floor.

Controller/Chiller units easily accommodate centralized or decentralized holding and rethermalization plans.

The Controller/Chiller provides a chilling function to the trays during the initial loading and holding phase and then maintains chilling for dishes that are served cold, during rethermalization of dishes that are served hot. The processor in the Controller/Chiller unit initiates the rethermalization sequence inside the System II Cart by turning on electrical power to the conduction heaters.

### Specifications

**CABINET EXTERIOR:** Heavy Gauge aluminum with a textured powder-coat. Front fascia and top are formed from a high impact, flame retardant plastic (UL approved).

**REFRIGERATION SYSTEM:** 208 Vac, single phase (internally fused) compressor with R404A refrigerant.

**ELECTRICAL REQUIREMENTS:** 208 Vac, 30 Amps, 3 phase WYE, 60 Hz, 5-wire grounded, Plug configuration: NEMA L-2130-P

**TEMPERATURE STATEMENT:** The chiller thermostatically maintains a System II cart at 38 degrees.

**MOBILITY:** The Chiller/Controller unit can be easily moved using a two wheel hand truck. This facilitates installation and allows for easy chiller relocation during renovation or hospital growth.

**CONTROL:** programmable electronic controller; self diagnostics for Chiller and System II cart; unsafe temperature display for HACCP monitoring.



**MANAGEMENT:** An A la Cart Central Management Control System (CMCS) can be added to any System II operation. It can program, monitor and control all units – on every floor, in remote buildings – right from a computer in an office or central kitchen. On-screen indicators provide real time information regarding the status of every Controller/Chiller unit, so you can track cart arrival and meal delivery times, as well as faults. CMCS generates temperature logs that document food safety compliance and produces management reports for HACCP control.

### Dimensions (WxLxH)

- 24" x 26" x 60.7"
- Weight: 242 lbs

**NOTES:**

**1. ELECTRICAL REQUIREMENTS:**

VOLTAGE (VAC)	208
CURRENT (Amps.)	30
WIRING	3 PHASE, 5 WIRE
PHASE A (Amps.)	13
PHASE B (Amps.)	22
PHASE C (Amps.)	12
NEUTRAL (Amps.)	9

**2. RECEPTACLE REQUIREMENT: NEMA NO. L21-30R,**

**3. AIR COOLED SYSTEM, REFRIGERATION REQUIREMENTS:**

- A. SYSTEM CHARGE, 404A 3lb.
- B. HEAT REJECTION 3580 BTU/HR. MIN. 4600 BTU/HR. MAX. @ 74°F. VALUE BASED ON 6 HRS RETHERM/DAY WITH NO OVERNIGHT CHILL.

**4. WATER COOLED SYSTEM, REFRIGERATION REQUIREMENTS:**

- WATER TEMPERATURE (MAX.): 80 DEGREES F.
- WATER FLOW RATE (GPM): 0.8 TO 1.5 @80 DEGREES F.
- INLET WATER PRESSURE (PSI): 30 TO 40 (REGULATED)
- SYSTEM PRESSURE DROP (PSIG): 3 TO 5 @0.8GPM
- WATER FILTRATION: 50 MICRON MINIMUM
- TEMPERATURE DIFFERENTIAL INLET TO OUTLET @ 80 DEG. F: 25 DEGREES F. NOMINAL
- OUTPUT AIR TEMP.: 10 TO 15 DEGREES F.
- EVAPORATOR TEMP.: -10 DEGREES F.
- SUCTION PRESSURE: 15 TO 30 PSI
- DISCHARGE PRESSURE: 225 TO 275 PSI
- SYSTEM CHARGE: 404A, 3 LBS.

**5. USE 304SS EXPANSION ANCHOR, APPROX. LN, 3/8X2-1/4**

**6. INSTALLATION MUST BE PERFORMED IN ACCORDANCE WITH LOCAL, STATE, AND NATIONAL CODES FOR YOUR SPECIFIC FACILITY. A LA CART, INC. PROVIDES THE INFORMATION CONTAINED HEREIN AS ONE POSSIBLE INSTALLATION METHOD. ANY INJURY OR DAMAGE TO EQUIPMENT DUE TO NEGLIGENCE OR IMPROPER INSTALLATION IS THE SOLE RESPONSIBILITY OF THE FACILITY. IMPROPER INSTALLATION MAY ALSO VOID THE EQUIPMENT WARRANTY.**

**7. UNI-STRUT IS 40" LONG X 1.62" WIDE X 1.62" HIGH.**

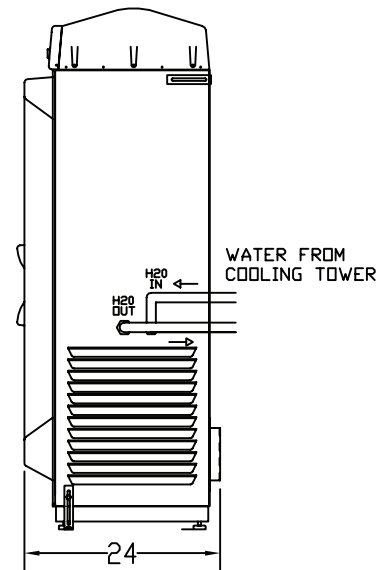
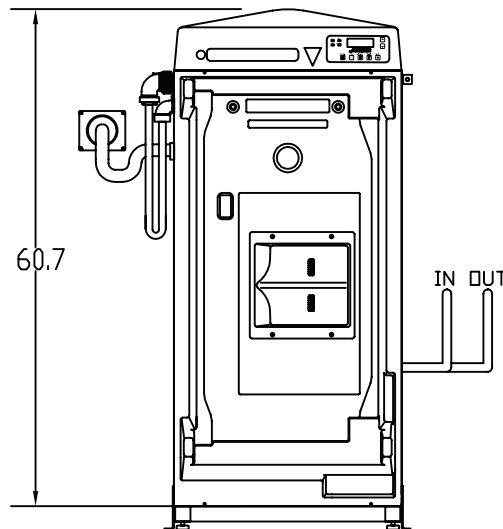
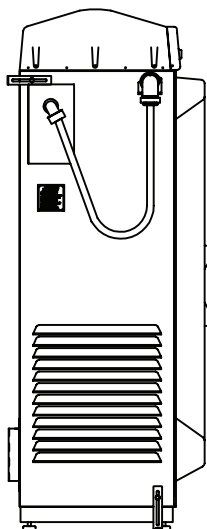
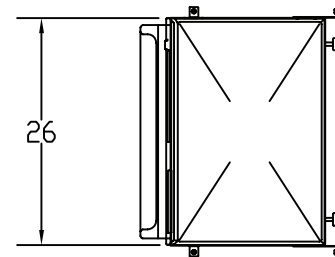

# Overview & Operating Instructions

## MENU PLANNING

With System II any menu format can be utilized, depending on your patients or clientele, length of stay, budget, and other factors. System II provides maximum flexibility with the type of food items to include in your menu that will result in excellent end point quality, due to the ability to customize heat intensity settings for the entrée and soup/side heaters separately for each mealtime. This allows for having a combination of different density foods on the same tray that retherm together with excellent results. You can confidently plan to include a variety of menu items of various density, thickness, texture, and moistness. All foods are prepared according to cook/chill standards, methods, and procedures, prior to plating.

## PLATING GUIDELINES

Many factors determine how hot foods are plated in System II which, in turn, affects the end result of rethermalization. These major factors include:

- food density
- thickness
- texture
- input temperatures
- food item's tolerance to heat
- type of dishware (plastic vs. china)

With System II you have the flexibility of setting the power intensity that is applied to the heaters during the retherm and hold cycles. This allows you to establish the appropriate end point temperatures for the rethermed plate quality you desire. It is done by setting "duty cycle values" for each meal on the entrée and side heaters. The duty cycle value is equal to the number of seconds per minute that a heater remains on during the retherm and hold cycles. Refer to the "Display Panel Instructions" in this manual for instructions on how to set the duty cycles. In general, meals that contain delicate more "easy-to-heat" items require a lower duty cycle value, such as breakfast items like scrambled eggs and French Toast. Meals that contain thick meats require a higher duty cycle value. The table below shows the standard duty cycles.

## Standard Duty Cycle Values

	REThERM CYCLE TOTAL MINS	BREAKFEAST ENTRÉE SEC/MIN	BREAKFAST SIDE SEC/MIN	LUNCH/ DINNER ENTRÉE SEC/MIN	LUNCH/ DINNER SIDE SEC/MIN
Factory Setting	38	60	60	60	60
China Dishware	38	45	55	55	55
Plastic Dishware	40	36	45	45	45

# Overview & Operating Instructions

Plating procedures are the most critical for the hot foods, or hot side of the tray, and will be addressed in this section. For cold foods, placement of items on the tray is important to ensure that the cold foods are set away from the heat, near the outer most edge of the cold side of the tray.

China dishware conducts heat differently than plastic dishware. It gets hotter more quickly and stays hotter for a longer period of time than plastic. China also distributes heat a little more evenly than plastic, although the center of the dish is always the hottest spot for both. Plastic dishware takes longer to heat, therefore the retherm time is generally longer than it is for china. Plating procedures need to be individualized for each facility based on their menu items, food consistency and the type of dishware used.

To simplify plating techniques all food items can be classified as easy or hard to heat. “Easy to heat” food items are low to the plate, moist, and have maximum plate contact. “Hard to heat” food items rest high on the plate, are dry, and very dense. Easy to heat items are made hard to heat by either placing away from the center of the dish, using a buffer under the product, placing on plate frozen (breakfast items only) and/or reducing heat time. Hard to heat items are made easier to heat by either placing in center of the dish, adding moisture to product, increasing plate surface contact, and/or increasing heat times. Ideal plating combinations are one hard to heat item with two easy to heat items. These points are illustrated in the Plating Principles below.

## PLATING PRINCIPLES

### TYPE OF HEAT: **CONDUCTION HEAT**

- Heat transfers from heating element -----> to dishware -----> to food
- Center of the plate is the hottest spot; heat transfers out to the edges

#### EASY TO HEAT

- Fish
- Eggs, Omelets
- Pancakes, French Toast
- Sliced Meats
- Sausage Patty
- Casseroles
- “Low” products
- Breakfast breads

#### TO MAKE HEATING “HARDER”

- place to side of dish
- use a buffer underneath (fruit slices, melba toast, etc.)
- place in high heat cup (i.e. eggs)
- plate partially frozen (breakfast items only)
- reduce heat time

#### HARD TO HEAT

- Baked Potatoes
- Whole Potatoes
- Bread Dressing
- Thick/dense meats
- Meats with bone
- Sausage links (rounded)
- “High” products (i.e. hot sandwiches)
- Hard Cooked Eggs (rounded)

#### TO MAKE HEATING “EASIER”



- place in center of dish
- add moisture
- add sauce
- increase plate surface area
- increase heat time

# Overview & Operating Instructions

It is highly recommended that **food product testing** be conducted on all menu items that will be rethermed to determine the proper plating of food items, and verify that the desired food consistency, quality, flavor and end temperature are met after rethermalization. When testing product, a complete entrée plate is to be tested. Ideally 6 to 10 trays of food are tested at a time. The emphasis in food product testing is evaluating food placement on the plate. A variety of plating options exist for some menu items, depending on what is desired as the end product. Each facility must decide on what is most acceptable to them in terms of presentation and food temperatures.

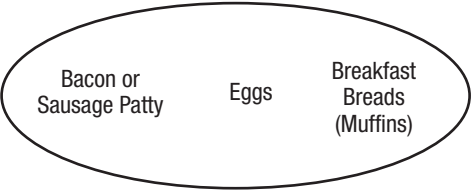
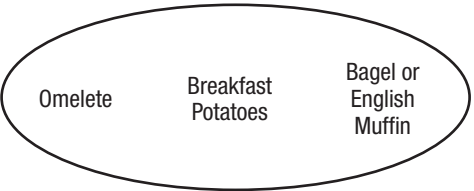

From the food product testing, plating diagrams can be developed to illustrate proper plating of menu items for your specific menu. See the sample plating diagrams below:

## Breakfast Examples (All Easy to Heat Items)

<ol style="list-style-type: none"> <li>1. <b>Hard Cooked Eggs:</b> Place in high heat cup in center of dish.</li> <li>2. <b>Bacon or Sausage Patty:</b> Place on side of the plate.</li> <li>3. <b>Breakfast Breads:</b> Place on a doily on edge of plate.</li> </ol>	
<ol style="list-style-type: none"> <li>1. <b>Scrambled Eggs or Omelete or Breakfast Burrito:</b> Burrito can be frozen.</li> <li>2. <b>Breakfast Potatoes:</b> Place in center of entree plate.</li> <li>3. <b>English Muffin or Bagel:</b> Toast and place toast side down on plate.</li> </ol> <p>Note: Breakfast burrito to be wrapped in foil.</p>	
<ol style="list-style-type: none"> <li>1. <b>French Toast or Pancakes:</b> Place pancakes or french toast to edge of plate.</li> <li>2. <b>Breakfast Meats:</b> Place on side of the plate.</li> </ol>	

# Overview & Operating Instructions

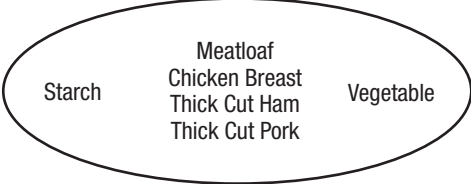
## Lunch or Dinner Examples (One Hard to Heat, Two Easy to Heat)

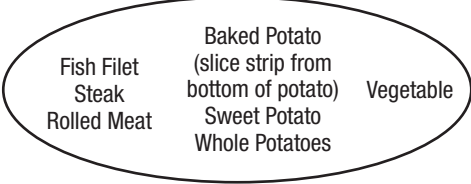
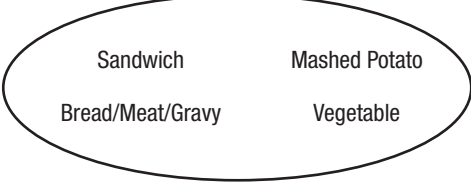
<p><b>Dense Meat</b> (Meatloaf, Chicken Breast, Ham, Pork) <b>Starch/ Vegetable</b></p> <ol style="list-style-type: none"> <li>1. Served meat in center of entree plate. Top with glaze or gravy.</li> <li>2. Serve vegetable and starch to each side of the meat.</li> </ol>	
<p><b>Casserole / Vegetable</b></p> <ol style="list-style-type: none"> <li>1. Lasagna is served in center of entree plate with tomato sauce on top. Layers not to exceed three. Lasagna to be fully baked and chilled prior to serving.</li> <li>2. Vegetables to side of dish.</li> <li>3. Bread, if used, serve across top of plate.</li> </ol> <p>Note: Meat casseroles or enchiladas to be served on top of rice. Beef stew can be served in bowl or on plate.</p>	
<p><b>Sliced and Delicate Meat</b> (thin sliced meat, steak, fish) <b>Baked Potato / Vegetable</b></p> <ol style="list-style-type: none"> <li>1. Roll sliced meat and place rolled and delicate meat to the side of the entree plate. Top with gravy or sauce.</li> <li>2. Serve baked potato in center of the entree plate. Cut thin strip from the bottom of the potato prior to serving to improve the plate contact.</li> <li>3. Serve vegetable to side of the plate.</li> </ol>	
<p><b>Hot Open Faced Sandwich</b></p> <ol style="list-style-type: none"> <li>1. Place bread on entree plate to the side of the dish.</li> <li>2. Cover bread completely with meat. Top with one ounce of gravy.</li> <li>3. Serve vegetable to the bottom side of plate.</li> <li>4. Serve the mashed potatoes to the top side of the plate and back scoop.</li> </ol>	

# Overview & Operating Instructions

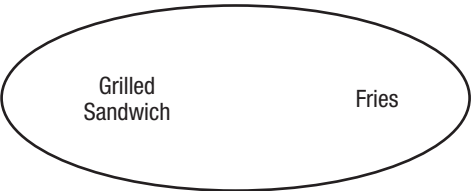
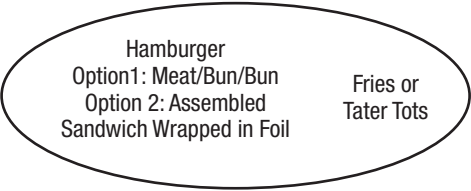
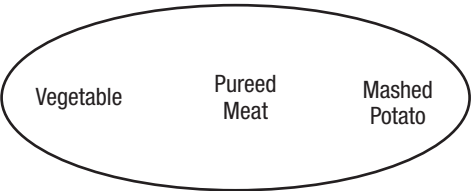

## Lunch and Dinner Sandwich Examples (Challenging Plating Styles)

<p><b>Grilled Sandwich / Fries</b></p> <ol style="list-style-type: none"> <li>1. Grilled sandwiches should be buttered on both sides, grilled on one side and served ungrilled side down to the entree plate.</li> <li>2. Grilled sandwiches should NOT be cut prior to serving.</li> <li>3. Steak fries for dry vegetable to be served to side of the plate.</li> </ol>	
<p><b>Hot Sandwich</b> (Hamburgers, Chicken Breast Filet, Cheese Burger)</p> <p><i>Option 1</i></p> <ol style="list-style-type: none"> <li>1. Serve hamburger patty in center of entree plate. Serve bun on top of patty.</li> <li>2. Serve steak cut fries or tater tots to the side of the entree plate.</li> </ol> <p><i>Option 2</i></p> <ol style="list-style-type: none"> <li>1. Assemble sandwich, wrap in foil and put in center of entree plate.</li> <li>2. Serve steak cut fries or tater tots to the side of the entree plate.</li> </ol>	
<p><b>Ground or Pureed Meat Entree / Vegetable / Mashed Potatoes</b></p> <p><i>Option 1</i></p> <ol style="list-style-type: none"> <li>1. Serve pureed meat and gravy in center of the entree plate.</li> <li>2. Mashed potatoes and vegetables in egg cup served to each side of the meat. Back scoop potatoes.</li> </ol> <p><i>Option 2</i></p> <ol style="list-style-type: none"> <li>1. Serve pureed meat in center of back scooped mashed potatoes with gravy placed at the top of the plate.</li> <li>2. Serve vegetables to the side of the plate in a high heat cup.</li> </ol> <p><i>Option 3</i></p> <ol style="list-style-type: none"> <li>1. Serve formed, frozen purees with meat in the center of the entree plate.</li> <li>2. The mashed potatoes and vegetables are served to the side of the dish. Back scoop the potatoes and place gravy (1 oz) in center.</li> </ol>	

You can develop your own plating diagrams using the forms on the following pages.

# Overview & Operating Instructions

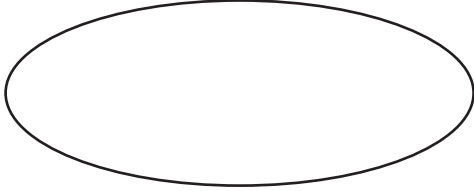
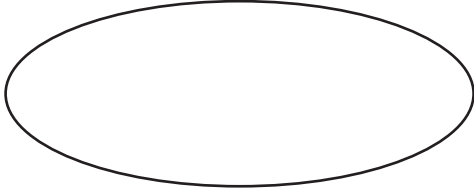
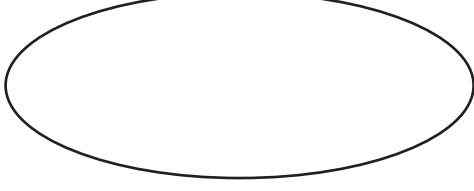
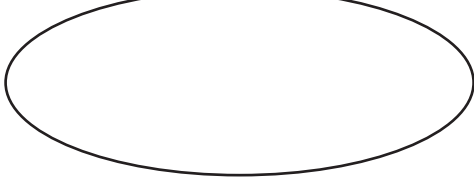
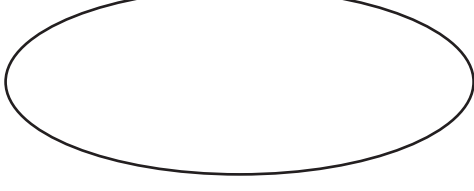
## Plating Diagram Form: China Dishware



# Overview & Operating Instructions

## TRAY PRESENTATION

Tray presentation for System II allows for a main plate hot entrée and soup or hot side dish on the **hot side** of the tray. It also allows for a cold plate entrée on the hot side of the tray, allowing maximum use of the tray space. This is accomplished by setting a “Menu Minder” card that controls the individual shelf heaters when the tray is loaded into the cart. The Menu Minder is set for each shelf heater to heat or not to heat, according to what food items are placed on the hot side of the tray.

The **cold side** of the tray accommodates all cold menu items such as entrée cold plates, salads, desserts, condiments, and cold beverages. Frozen desserts are added to the tray at the time of meal service. The cold items are chilled by super-cold circulating air throughout the cart.

## PLACEMENT OF DISHWARE

The same principles of dishware placement on the tray apply to both plastic and china. The only difference is that when setting up a tray with china, a “cradle” is utilized to hold the entrée plate and soup bowl in place over the heaters.

The following are basic rules for placement of dishware on the hot side of the tray, with the hot side closest to you:

1. The entrée plate is ALWAYS placed to the right. This is also the correct placement for a main dish cold plate. The Menu Minder card is set according to hot or cold entree.
2. The soup/side dish is ALWAYS placed to the left when used alone or in combination with an entrée plate.
3. Two soup/side dishes alone are ALWAYS placed to the right. The entrée slide is set to hot on the Menu Minder card. Note: recommended for plastic soup bowls only.
4. Three soup/side dishes alone are ALWAYS placed together on both the right and left sides, in a row. Note: recommended for plastic soup bowls only.

The tray presentation diagrams on the following pages illustrate the correct placement of dishware and food items on the tray. Correct dishware placement is important so that the dishware rests on top of the large or small heating elements, allowing proper heating.

# Overview & Operating Instructions

## Tray Presentation: China Dishware

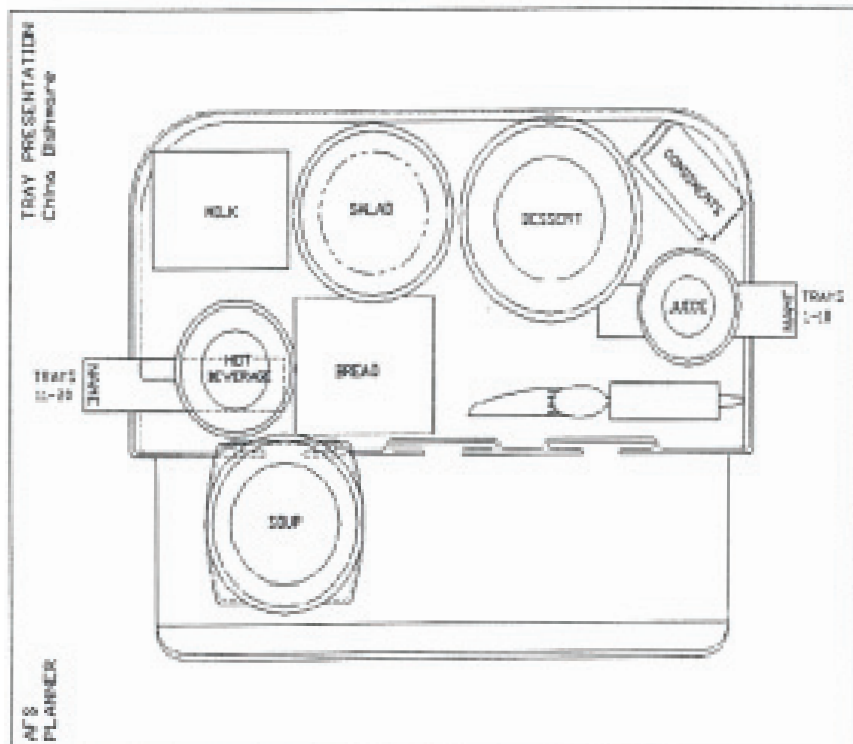
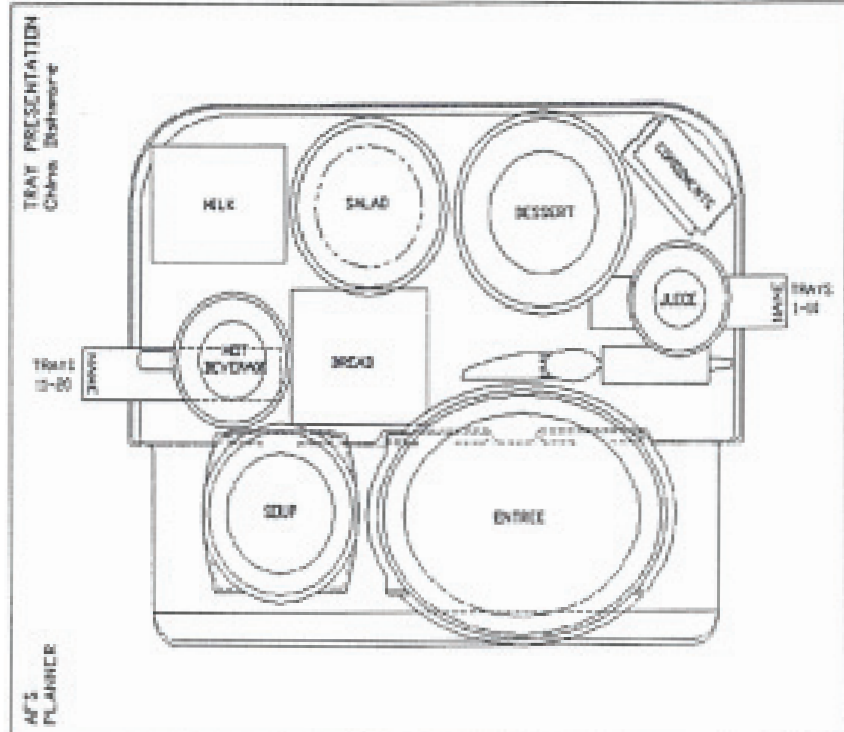

# Overview & Operating Instructions

## Tray Presentation: Plastic Dishware

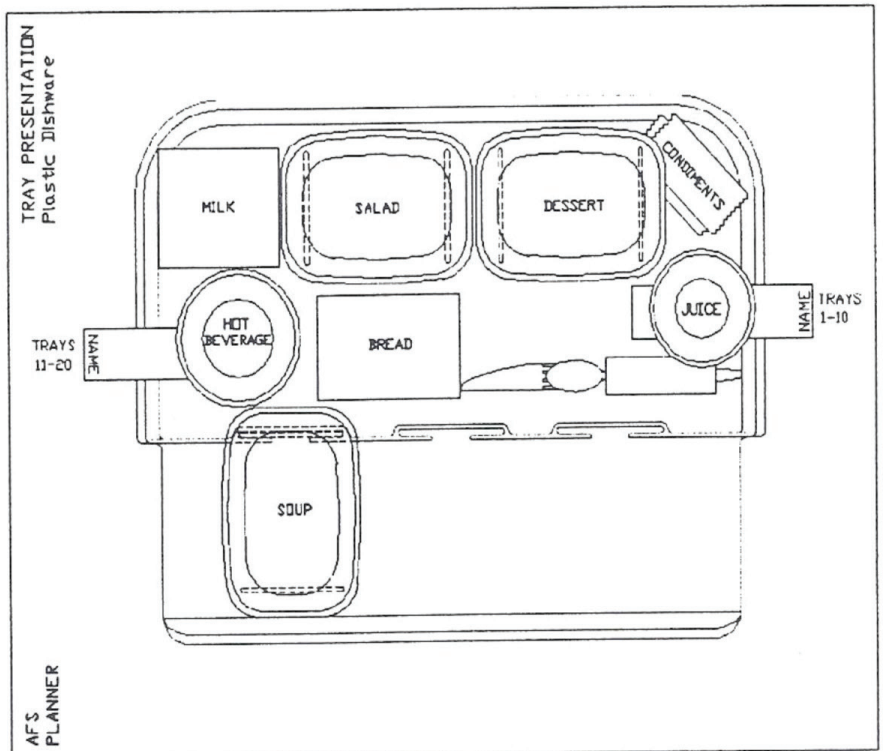
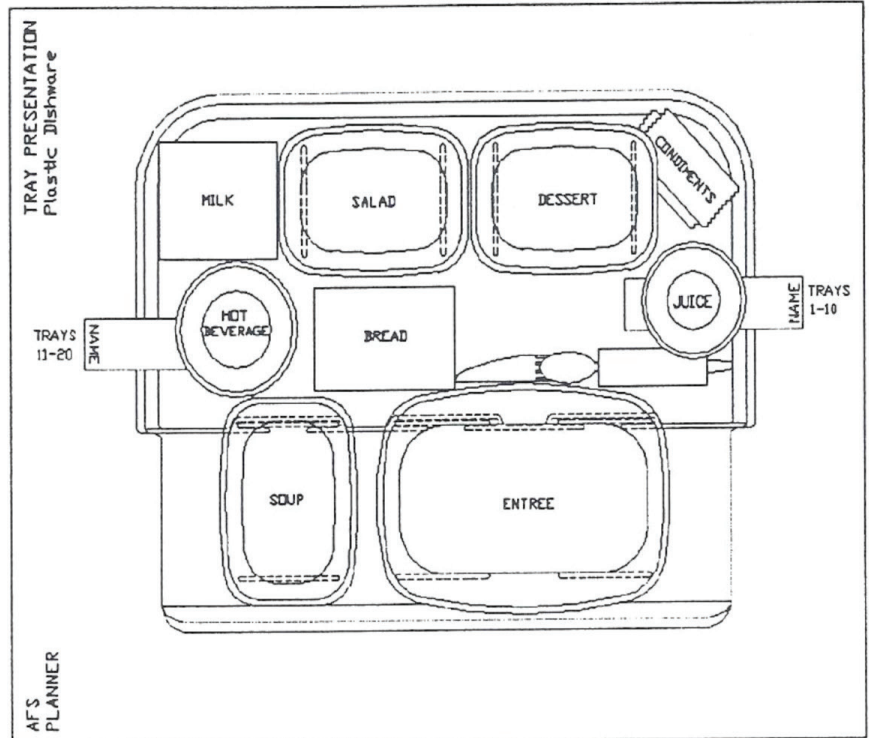

# Overview & Operating Instructions

## Tray Presentation: Plastic Dishware

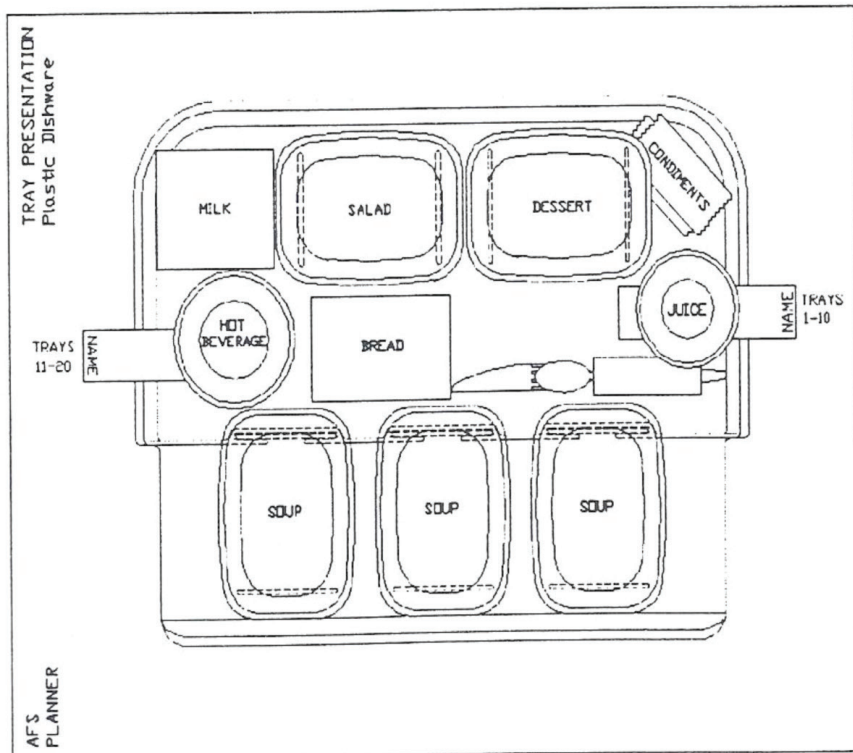
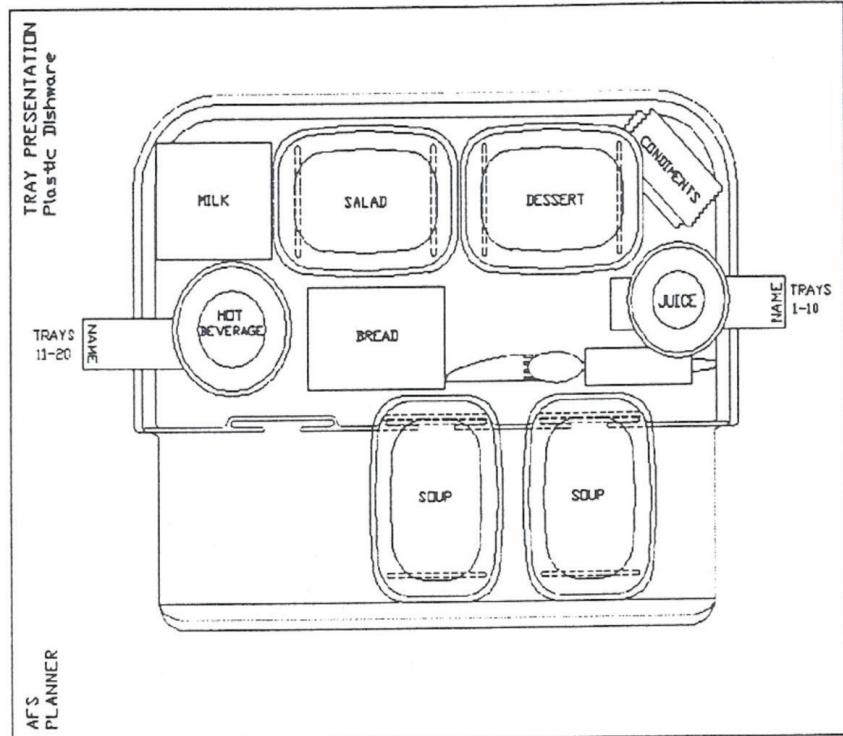

# Overview & Operating Instructions

## DISPLAY PANEL INSTRUCTIONS

### The 4-Line LCD Display Screen

Top 3 lines:	Displays Docking status, Meal Start Times, Operator Messages, and information to setup parameters
Bottom Line:	Displays Time, Date, Return Air (RET) and Input Air (INPUT) temperatures, Error Messages
<b>REThERM Button</b>	Starts/Stops a manual Retherm cycle
<b>HOLD Button</b>	Starts/Stops a manual Hold cycle
<b>BACKLIGHT Button</b>	Turns the display backlight ON/OFF
<b>OPTIONS Button</b>	Accesses the Options menus and saves displayed parameters during parameter setup
<b>ENTER Button</b>	Used to select options and set parameters, and moves cursor horizontally on the screen
<b>UP/DOWN<sup>↑</sup><sub>↓</sub> Buttons</b>	Used to navigate vertically through the Options menus
<b>Chill Light (Blue)</b>	Illuminates when a cart has been docked
<b>Retherm Light (Red)</b>	Illuminates when a Retherm cycle is in process and flashes during the automatic heater check
<b>Ready Light (Green)</b>	Illuminates when a Hold cycle is in process
<b>Fault Light (Yellow)</b>	Illuminates when a fault has been detected

# Overview & Operating Instructions

## Normal Operation & Sequence of Events:

STATUS/ ACTIVITY	DISPLAY SHOWS	COMMENTS
Cart Undocked (Idle)	MENU MINDER: NO CART DOCKED: NO CART PLUGGED: NO	-
Cart Docking Completed	MENU MINDER: YES CART DOCKED: YES CART PLUGGED IN: YES	Chiller beeps during docking until all steps are completed and “yes” is displayed by each. When all docking steps are completed the display shows retherm start times.
Automatic Heater Check	Red Light flashes when heater check is completed.  Yellow Light is ON if fault/error is detected.  Error messages appear on bottom display line at 5 second intervals.	Heater check is automatically performed each time cart is docked; takes 20 seconds.  Error message includes the specific entrée or side heater that is disabled (Example: SIDE 1 OPEN CKT); all other heaters work; error messages are automatically stored in the Error Log in Options menu.
Cart Docked (Chilling)	BRKFST START 7:00 AM LUNCH START 11:30 AM DINNER START 5:00 PM  Blue Light is ON	Automatic retherm start times for each meal appear on display as programmed; if no times are preset, times will read as “Not Set”.
Cart Docked (Retherming)	REHERM IN PROCESS TIME LEFT: 38 MIN  Red Light is ON	Chiller automatically starts retherm at the programmed time or manually when retherm button is pressed; display shows number of minutes left in retherm cycle until completed.
Cart Docked (Holding)	HOLD IN PROCESS TIME ELAPSED: 3 MIN  Green Light is ON	Hold cycle automatically begins at the end of retherm or manually when hold button is pressed; display shows number of minutes cart has been in hold cycle; hold cycle will automatically stop when maximum hold time is reached (default is 60 min.).
Cart Undocking Completed	CART NOT PLUGGED IN STOP CYCLE: 5 MIN HOLD = FORCE STOP	Once undocking is completed screen appears for 5 minutes then returns to idle screen, or pressing Hold returns it to idle.

# Overview & Operating Instructions

## Using Manual Retherm & Hold Cycles:

ACTIVITY	STEPS/DISPLAY SHOWS	COMMENTS
START Manual Retherm Cycle	<ol style="list-style-type: none"> <li>1. Press Retherm button: START RETHERM CYCLE? HIT ENTER TO CONFIRM</li> <li>2. Press Enter button: WHICH DUTY CYCLE? OPTIONS = BREAKFAST ENTER = LUNCH/DINNER</li> <li>3. Press either Options button for Breakfast, OR Enter button for Lunch or Dinner: REThERM IN PROCESS TIME LEFT: 38 MIN</li> </ol> <p>Red Light will be ON.</p>	Manual Heating parameter must be set to "ON" to start a manual retherm cycle. This parameter is found under the OPTIONS menu in Factory Parameters.
STOP Manual Retherm Cycle	<ol style="list-style-type: none"> <li>1. Press Retherm button: REThERM IN PROCESS STOP RETHERM? HIT ENTER TO CONFIRM</li> <li>2. Press Enter button: BRKFST START Time AM LUNCH START Time AM DINNER START Time PM</li> </ol> <p>Blue Light will be ON until cart is undocked.</p>	Once ENTER is pressed the screen will return to the meal start time display and chilling will continue until cart is undocked.
START Manual Hold Cycle	<ol style="list-style-type: none"> <li>1. Press Hold button: START HOLD CYCLE? HIT ENTER TO CONFIRM</li> <li>2. Press Enter button: HOLD IN PROCESS TIME ELAPSED: 0 MIN</li> </ol> <p>Green Light will be ON.</p>	Hold cycle will automatically stop when maximum hold time is reached (default is 60 min.). Elapsed time will go to 60 and return to chill mode if cart is still docked.
STOP Manual Hold Cycle	<ol style="list-style-type: none"> <li>1. Press Hold button: HOLD IN PROCESS STOP HOLD? HIT ENTER TO CONFIRM</li> <li>2. Press Enter button: BRKFST START Time AM LUNCH START Time AM DINNER START Time PM</li> </ol> <p>Blue Light will be ON until cart is undocked.</p>	Once Enter is pressed the screen will return to the meal start time display and chilling will continue until cart is undocked.

# Overview & Operating Instructions

## Using "OPTIONS" Menu, Reading Error Log, & Setting Password:

ACTIVITY	STEPS/DISPLAY SHOWS	COMMENTS
<p>Access OPTIONS Menu (No Password Set)</p> <p>(OPTIONS menu contains all equipment parameter settings)</p>	<p>1. <i>Press Options button:</i> &gt;MEAL PARAMETERS HEATER PARAMETERS FACTORY PARAMETERS ENTER = EDIT, OPTIONS = QUIT</p>	<p>See the following pages for the parameter settings included within each group of parameters.</p>
<p>Access OPTIONS Menu (Password Already Set)</p> <p>(OPTIONS menu contains all equipment parameter settings)</p>	<p>1. <i>Press Options button:</i> ENTER PASSWORD 000 ^^</p> <p>2. <i>Enter password using the Enter button to move the (^^) across on setting and the up or down keys to change values.</i></p> <p>3. <i>Press Options button when correct values are displayed:</i></p> <p>Screen First Shows: PASSWORD ACCEPTED</p> <p>Screen Then Shows: &gt;MEAL PARAMETERS HEATER PARAMETERS FACTORY PARAMETERS ENTER = EDIT, OPTIONS = QUIT</p>	<p>The password is a 3-digit numeric setting. Holding down the up or down key while pressing allows quick scrolling.</p> <p>If the password is entered incorrectly the display will show: PASSWORD REJECTED</p> <p>See the following pages for the parameter settings included within each group of parameters.</p>
<p>View/Change Meal Parameters</p>	<p>1. <i>Complete steps under "Access OPTIONS menu".</i></p> <p>2. <i>With Meal Parameters already selected press the Enter button to go to parameters list.</i></p> <p>3. <i>Use the up or down keys to scroll through parameters list to select a setting.</i></p> <p>4. <i>Press Enter button to edit or change the selected setting.</i></p> <p>5. <i>Use the Enter button to move the (^^) horizontally on the setting and the up or down keys to change values of the setting:</i></p> <p>Example Screen: BREAKFAST TIME 07:00 AM ^^ ENTER = EDIT, OPTIONS = QUIT</p> <p>6. <i>Press Options button to save changes and return to previous screen.</i></p>	<p><i>Meal Parameter Settings:</i> Breakfast Time (sets retherm start time) Lunch Time (sets retherm start time) Dinner Time (sets retherm start time) Retherm Time (sets retherm time in minutes) Hold Time (sets hold time in minutes) Current Time (sets current time/chiller clock) Current Date (sets current date) Daylight Savings (turns on/off daylight savings mode)</p> <p>It is important that AM/PM designation is correct when setting meal start times.</p>

# Overview & Operating Instructions

## Using “OPTIONS” Menu, Reading Error Log, & Setting Password:

ACTIVITY	STEPS/DISPLAY SHOWS	COMMENTS
View/Change Heater Parameters	<ol style="list-style-type: none"> <li>1. Complete steps under “Access OPTIONS menu”.</li> <li>2. Move the “&gt;” down to Heater Parameters using the down key and press Enter button to go to parameters list.</li> <li>3. Use the up or down keys to scroll through parameters list to select a setting.</li> <li>4. Press Enter button to edit or change the selected setting.</li> <li>5. Use the up or down keys to change values of the setting:  Example Screen: BREAKFAST ENTREE 45 (sec/min) ^^ ENTER = EDIT, OPTIONS = QUIT</li> <li>6. Press the Options button to save changes and return to previous screen</li> </ol>	<p>Heater Parameter Settings: Breakfast Entrée (sets duty cycle for breakfast entrée heater) Breakfast Side (sets duty cycle for breakfast side heater) Lunch Entrée (sets duty cycle for lunch &amp; dinner entrée heater) Lunch Side (sets duty cycle for lunch &amp; dinner side heater) Hold Cycle (sets duty cycle for Hold cycle)</p> <p>Heater intensity value indicates how many seconds per minute the heater remains ON during Retherm and Hold cycles.</p>
View/Change Factory Parameters	<ol style="list-style-type: none"> <li>1. Complete steps under “Access OPTIONS menu”.</li> <li>2. Move the“ &gt;” down to Factory Parameters using the down key and press Enter button to go to parameters list.</li> <li>3. Use the up or down keys to scroll through parameters list to select a setting.</li> <li>4. Press the Enter button to edit or change the selected setting.</li> <li>5. Use the Enter button to move the (^ ^) horizontally on the setting and the up or down keys to change values of the setting:  Example Screen: ENTER PASSWORD 000 ^^ ENTER = EDIT, OPTIONS = QUIT</li> <li>6. Press the Options button to save changes and return to previous screen</li> </ol>	<p>Factory Parameter Settings: Error Log (used to access last 10 faults) Enter Password (used to set a password)</p> <p>*Other Parameters for Technical Service Only: Compressor Points Defrost Interval Max. Defrost Time Entrée Current Side Current Max. Interrupt Time Max. Evaporator Time Manual Heating Temperature Display Temperature Scale Factory Reset</p> <p>*Refer to Technical Service Manual for information on these parameters.</p>

# Overview & Operating Instructions

## Using "OPTIONS" Menu, Reading Error Log, & Setting Password:

ACTIVITY	STEPS/DISPLAY SHOWS	COMMENTS
Access/Read Error Log	<ol style="list-style-type: none"> <li>1. Complete steps under "Access OPTIONS menu".</li> <li>2. Move the "&gt;" down to Factory Parameters using the down key and press Enter button to go to parameters list.</li> <li>3. Position the "&gt;" in front of Error Log. Press Enter button to access the Error Log.</li> <li>4. Any faults stored in the ERROR LOG will be displayed on the screen:  Example Screen: SIDE 1 OPEN CKT DATE: 07/07/07 TIME: 10:30 AM ENTER NEXT, OPTIONS = QUIT</li> <li>5. Press Enter button to view the next fault. If there are no other faults the display shows: ERROR LOG EMPTY OPTIONS = QUIT  Yellow Light is OFF</li> <li>6. If no cart is docked press the Options button until the cart status screen is displayed OR, if a cart is docked, continue to press Options until the meal start time screen is displayed.</li> </ol>	<p>The Error Log cannot be accessed if the unit is in the Retherm or Hold cycles.</p> <p>The Error Log stores up to the TEN most current faults recorded.</p>
Set Chiller Password	<ol style="list-style-type: none"> <li>1. Complete steps under "Access OPTIONS menu".</li> <li>2. Move the "&gt;" down to Factory Parameters using the down key and press Enter button to go to parameters list.</li> <li>3. Position the "&gt;" in front of Enter Password. Press Enter button: ENTER PASSWORD 000 ^^</li> <li>4. Enter password using the Enter button to move the (^) across on setting and the up or down keys to change values.</li> <li>5. Press Enter button when correct values are displayed: OPTIONS = QUIT</li> <li>6. Press Options button to save changes and return to idle or previous screen.</li> </ol>	<p>The password can be any 3-digit numeric setting.</p> <p>Holding down the up or down key while pressing allows quick scrolling.</p> <p>Once the password is set, if it is forgotten in the future the password can be bypassed by using a Julian calendar to enter the Julian equivalent for the current date as the password:</p> <p>Example password per Julian calendar: If current date is February 15 the Julian calendar date = 046 (has to be 3 digits). January 1 to February 15 = 46 days.</p>

## CART LOADER CHECKLIST

- Menu Minder switches **MATCH** each tray for heater settings and shelf number.
- Entree Plates are **covered**.
- Soup/Cereal lids are on **tight**.
- Cradles' "feet" are in **ridge** of tray.
- Tray slides **UNDER** heater.
- Tray drops behind **lip edge** of shelf.
- Trays are loaded from **top down**.
- Patient's name and room number are **visible**.

# Overview & Operating Instructions

## DOCK CART TO CHILLER

**REMEMBER:**  
**DOCK IT – LOCK IT – SOCKET**  
**– PULL FROM POCKET**

**Dock it, lock it, socket, and pull from pocket:**

- Open back door of cart.
- Dock cart to chiller. BLUE light is on. Chiller starts beeping.
- Lock wheel brakes.
- Plug Cable Connector into socket. Turn connector to right until it clicks and yellow dots line up.
- Place Menu Minder in chiller pocket. Chiller stops beeping.

**REMEMBER:**  
**STOP – LOOK – LISTEN**

**Stop, look, and listen:**

- Stop - wait for red flashing light on display board to turn off.
- Look - check display for any fault messages, and that the blue light is on.
- Listen - make sure the chiller is not beeping.

## UNDOCK CART FROM CHILLER

**REMEMBER:  
RELEASE SOCKET –  
UNLOCK IT – UNDOCK IT  
– PULL FROM POCKET**

**Release socket, unlock it, undock it, and pull from pocket:**

- When GREEN ready light is on turn Cable Connector to left until it releases from socket.
- Unlock wheel brakes on cart. Pull cart away from chiller.
- Pull Menu Minder from chiller pocket.
- Place Menu Minder in back door of cart and shut door.
- Display shows:
  - Cart Not Plugged in.
  - Stop cycle: 5 min.
  - Hold = Force Stop.

This display will remain for 5 min.

# Overview & Operating Instructions

## CART CLEANING

- Open cart doors and remove all items from cart.
- Remove Menu Minder. Close all switches. Run it through dish machine ONLY if soiled.
- Spray heater shelves and inside of cart with approved cleaner (Oasis 146, Mikro-Quat, Render II or D10). Let set 5 minutes. Wipe with clean damp cloth.
- For heavy food soil only: Spray heater shelves with approved degreaser\* Grease Cutter NC or Grease Beast or D3 or Grease Relief. Let set 5 minutes. Scrub off soil with approved white nylon pad. Rinse with water; wipe dry.
- Cover electrical outlet with cap. Spray outside of cart with approved cleaner. Wipe with clean damp cloth.

*\* Degreaser is NOT necessary for heaters with nonstick dark protective coating (PN 97492-1 & 2).*

# Overview & Operating Instructions

## DISHWARE CARE - CHINA

- SEPARATE and place entree and side cradles in flat rack. Scrape and SORT dishware.
- Load sorted dishes into dish machine and wash.
  - Detergent/rinse agent: Solid Power/Polydry  
(High Temp Washing-Ecolab)  
Ultraklene Plus/Ultra Dry  
(Low Temp Washing-Ecolab)
- Wash and rinse water temperature not to exceed 180° F.
- SOAK dishes that do not come clean. Use an approved light duty nylon scrubber to remove tough soil. Run through dish machine again.
- STORE clean dishware in carts or racks:
  - Cradles in Basket Rack (separated)
  - Trays on Tray Drying Rack (rimmed edge down)
  - Entree dishes in Entree Dish Cart
  - Soup & side dishes in Side Dish Cart
  - Domes in Entrée Cover Rack (right side up)

# Overview & Operating Instructions

## DISHWARE CARE - PLASTIC

- Scrape and SORT dishware. SOAK entree plates and soup bowls in hot water for 15 minutes in one of the following:
  - Bleach (1 cup to 20 gallons hot water)
  - Silver Power–Solid or Soilmaster (water at least 120° F. - Ecolab)
  - K2 (water at least 120° F. – Johnson Diversey)
- Load sorted dishes into dish machine and wash.
  - Detergent/rinse agent: Solid Power/Polydry (High Temp Washing-Ecolab)
  - Ultraklene Plus/Ultra Dry (Low Temp Washing-Ecolab)
- Wash and rinse water temperature not to exceed 180° F.
- SCRUB dishes that do not come clean with an approved light duty nylon scrubber. Run through dish machine again.
- STORE clean dishware in carts or racks:
  - Trays on Tray Drying Rack (rimmed edge down)
  - Entree dishes in Entree Dish Cart
  - Soup & side dishes in Side Dish Cart
  - Domes in Entrée Cover Cart

# Overview & Operating Instructions

## APPROVED CLEANING AGENTS FOR USE WITH 'A LA CART EQUIPMENT

**Product Information:**  
**Ecolab 1 (800) 352-5326**  
**Johnson Diversey 1 (800) 626-5015**

USES	PRODUCT NAME/ MANUFACTURER	PRODUCT TYPE	DILUTION FACTOR/COM- MENTS
Cart cleaning	<b>MicroQuat or Oasis 146</b> Ecolab	Sanitizer	Standard dilution; Oasis 146 is automatically diluted in dispenser,
Cart cleaning	<b>Render II or D10</b> Johnson Diversey	All purpose cleaner and sanitizer	200 ppm (1/4 oz per gal of water)
Cart cleaning – for stainless steel	<b>EcoShine</b> Ecolab	Cleaner/ Polisher	Ready to use.
Cart cleaning – for stainless steel	<b>Deep Gloss</b> Johnson Diversey	Cleaner/ Polisher	Ready to use.
Removal of baked on spills on heater elements.	<b>Grease Cutter NC or Oasis 133</b> Ecolab	Cleaner/ Degreaser	Less than 6% final concentration (3/4 cup per gal water)
Removal of baked on spills on heater elements	<b>Grease Beast or D3</b> Johnson Diversey	Degreaser	Less than 6% final concentration (3/4 cup per gal water)
Presoaking plastic dishware	<b>Bleach</b>	Bleacher	1 cup per 20 gal of water.
Presoaking plastic dishware	<b>Soilmaster or Silver Power-Solid</b> Ecolab	Enzyme presoak	Use in water at 120°F. or hotter.
Presoaking plastic dishware	<b>MikroClor</b> Ecolab	Bleacher, sanitizer	Follow manufacturer's instructions to dilute.
Presoaking plastic dishware	<b>K2</b> Johnson Diversey	Oxygen presoak	Use in water at 120°F. or hotter.
Dishwashing Detergent	<b>Solid Power Ultra Klene Plus</b> (low temp) Ecolab <b>Suma Super L1 Low Energy – LED</b> Johnson Diversey	Wash Agent	-
Dishwashing Rinse Agent	<b>Poly Dry Ultra Dry</b> (low temp) Ecolab <b>Suma Select A7</b> Johnson Diversey	Rinse Agent	-

# Troubleshooting Guide

## FAULTS & ERRORS

ERROR MESSAGE	WHAT IT MEANS	RECOMMENDED ACTION
<b>SOFT FAULT - NON FATAL ERROR</b>		
<b>Entrée Heater Failure Open Ckt</b> Error message includes shelf #	Cart and chiller cannot communicate regarding a specified heater component (side or entrée) on a specified shelf because there is no electrical current flow. This can be a blown fuse in the chiller, a failed heater component in the cart, bad connector pin or cable assembly wire.	Undock cart and clear fault from chiller, recording them on the Cart Chiller Maintenance Log. Dock cart to another chiller and see if fault message recurs. If so, the cart is the source of the problem. Otherwise, dock a good cart to the same chiller and see if the fault recurs. If so, the chiller is the source of the problem. If the fault does not recur at all, then it was likely a docking error. Re-dock the cart to it's designated chiller, and finally, move the affected tray to a heater shelf that is working, and reset the menu minder. System is operational, but service is required.
<b>Side Heater Failure Open Ckt</b> Error message includes shelf #		
<b>Entrée Heater Short Ckt</b> Error message includes shelf #		
<b>Side Heater Short Ckt</b> Error message includes shelf #		
<b>Menu Minder Entrée Failure LED</b> Error message includes shelf #	The system cannot read the menu minder for the specified entrée or side component of the heater on the specified shelf. System still operational, but shelf may not heat properly. It may not heat even when programmed hot, and it may heat even if programmed cold. Service required to repair if recurs.	Move the affected tray to a heater shelf that is working, and reset the menu minder. System is operational, but service is required.
<b>Menu Minder Side Failure LED</b> Error message includes shelf #		
<b>Menu Minder Locator Failure LED</b> Message specifies #1 or #2	There are 2 locator devices that read the menu minder. One or both of them (1 and/ or 2) has failed and cannot read the menu minder. If both fail, it cannot be used. If one fails, and the idle screen changes to menu minder "yes" when docking, it will retherm. If it keeps beeping and remains "menu minder no" after docking is complete, it will not retherm.	If one locator is faulting and it is reading the menu minder when you dock the cart, it is operational, but service is still required.
<b>Defrost Failure</b>	The maximum defrost cycle is 10 minutes. A failure may mean the defrost termination switch failed.	You may continue to use the system, but if the fault recurs, call for service.
<b>Cart Undocked Fault</b> Remove Cart, ENTER to continue	The cart has come undocked during the chill cycle, but the menu minder is still in and the cable is connected. 90 minutes after the cart comes off the docking switches, this message appears. Human intervention is required.	The food has not been actively refrigerated for over 90 minutes. Check food temperature with probe. If food has not been out of temperature range for too long, re-dock the cart and press ENTER and the cart will resume chilling. If you judge the food to be compromised, than discard and replace food. The fault does not have to be cleared from CMCS or Error log.
<b>Power Fail(ed)</b> Messages will vary depending on which cycle the chiller is in: Chill, Retherm or Hold.	There was a power failure that exceeded the "interrupt time." The interrupt time is 90 minutes if chilling, 5 minutes if retherming or holding. Messages will read as "Power failed during chill more than 90 ms, Food may be ruined," "Power Fail exceeded Int. time in retherm, Food may be ruined" or "Power failed while holding, the Food may be ruined"	Cart must be undocked for screen to clear. Then, cart can either be re-docked (if it was chilling and is found to be safe;) Served if it was holding and is found to be hot enough; or put back into the retherm cycle and undocked when trays are hot enough. Human intervention is required to continue operation, but the fault does not have to be cleared from CMCS or Error log.

# Troubleshooting Guide

## FAULTS & ERRORS

ERROR MESSAGE	WHAT IT MEANS	RECOMMENDED ACTION
<b>HARD FAULT - FATAL ERROR</b>		
<b>Return Air Temperature Failure</b> Chiller will beep and display “Fatal Error Service Required” message	Return air (air circulating from cart into chiller) does not achieve 55° temperature within 90 minutes of docking the cart. Usually environment e.g. high room temperature >80°, poor docking seal, blocked chiller vents.	Check environment and correct issue. Undock cart, turn chiller off and back on, allowing the LED display panel to reboot until idle screen appears. Re-dock cart to chiller and continue to operate. If problem does not recur, or environmental factor is not evident, call for service.
<b>Input Air Temperature Failure</b> Chiller will beep and display “Fatal Error Service Required” message	Input air (air circulating from chiller into cart) does not drop below 35° within 15 minutes of docking the cart. Service required. Usually equipment refrigeration issues, not safe to operate, service required.	Take unit out of service, unless very obvious environmental factor is evident (eg. cart door open for 15 min.) If environment, correct issue, power chiller off and on, reboot LED display to idle screen. Re-dock and see if problem recurs. If so, service required.
<b>Water Pressure Fail</b> (water cooled units)	Water pressure required to run refrigeration was not achieved.	Undock the cart and power the chiller off and then back on. Take chiller out of service until water pressure issue is corrected. Service is required.











1055 Mendell Davis Drive • Jackson MS 39272  
888-994-7636 • 601-372-3903 • Fax 888-864-7636  
[unifiedbrands.net](http://unifiedbrands.net)