

# Hot Food Holding Cabinets

**1000-S**  
**1000-UP**



**Units built December 2023—March 2025**

## Manufacturer's Information

### Copyright

© Copyright 12/23 by Alto-Shaam, Inc.  
 All rights reserved.  
 This manual or any portion thereof may not be reproduced or used in any manner whatsoever without the express written permission of Alto-Shaam, Inc

### Trademarks

All trademarks referenced in this documentation are the property of their respective owners.

### Manufacturer

Alto-Shaam, Inc.  
 P.O. Box 450  
 W164 N9221 Water Street  
 Menomonee Falls, WI 53052

### Models Covered

1000-S 1000-UP	Heated Holding Cabinets
-------------------	-------------------------

### Serial Number

The unit serial number is required for identifying and ordering the correct service parts.  
 Record the unit serial number below for reference.

Serial Number

### Parts Finder Tool

Interactive diagrams from this Parts Manual are available online at our Parts Finder Tool:  
<https://www.alto-shaam.com/en/customer-support/parts>.  
 Or, scan the QR code below.



### Parts Ordering Information

Original manufacturer's replacement parts may be ordered directly from the Alto-Shaam network of Authorized Service Agents and Parts Distributors. Follow this link for a map to a local partner: <https://www.alto-shaam.com/en/how-to-buy>. If you are an Authorized Service Agent or Parts Distributor, please submit your purchase order to [parts@alto-shaam.com](mailto:parts@alto-shaam.com).

Non-OEM parts may be substituted; however, these parts must be of equal quality and specifications as those provided by Alto-Shaam.

# Table of Contents

Manufacturer's Information.....2  
 Table of Contents .....3  
 1000-S Exterior Panel Package "A", Reach-In .....4  
 1000-S Exterior Panel Package "B", Pass-Thru .....5  
 1000-UP Exterior Panel Package "A", Reach-In .....6  
 1000-UP Exterior Panel Package "B", Pass-Thru .....7  
 1000-UP Exterior Panel Package "C", Recessed Handles .....8  
 1000-S Core Assembly, Reach-In, Simple .....9  
 1000-S Core Assembly, Reach-In, Deluxe .....10  
 1000-UP Core Assembly, Reach-In, Simple .....11  
 1000-UP Core Assembly, Reach-In, Deluxe .....12  
 1000-UP Core Assembly, Pass-Thru, Simple.....13  
 1000-UP Core Assembly, Pass-Thru, Deluxe .....14  
 Heating Wire Service Kits.....15  
 1000-S Cavity Package "A", Reach-In .....16  
 1000-S Cavity Package "B", Pass-Thru .....17  
 1000-UP Cavity Package "A", Reach-In .....18  
 1000-UP Cavity Package "B", Pass-Thru .....19  
 1000-UP Cavity Package "C", Reach-In Proofer.....20  
 1000-UP Cavity Package "D", Pass-Thru Proofer.....21  
 Bumper Assembly (optional).....22  
 1000-S Bonnet Package "A", Manual 120V .....23  
 1000-S Bonnet Package "B", Manual 208V-240V.....24  
 1000-S Bonnet Package "C", Manual 230V .....25  
 1000-S Bonnet Package "D", Electronic Control 120V .....26  
 1000-S Bonnet Package "E", Electronic Control 208V-240V .....27  
 1000-S Bonnet Package "G", Electronic Control w/Timer 120V.....28  
 1000-S Bonnet Package "I", Electronic Control w/Timer 230V .....29  
 1000-S Bonnet Package "Q", Electronic Control w/Timer 120V Rev Door .....30  
 1000-UP Bonnet Package "A", Manual 120V .....31  
 1000-UP Bonnet Package "B", Manual 208V-240V.....32  
 1000-UP Bonnet Package "C", Manual 230V.....33  
 1000-UP Bonnet Package "D", Electronic 120V .....34  
 1000-UP Bonnet Package "E", Electronic 208V-240V .....35  
 1000-UP Bonnet Package "G", Electronic w/Timer 120V.....36  
 1000-UP Bonnet Package "I", Electronic w/Timer 230V .....37  
 1000-UP Bonnet Package "J", Electronic w/Probe 120V .....38  
 1000-UP Bonnet Package "L", Electronic w/Probe 230V .....39  
 Chassis Assembly, S-Series, Manual 120V .....40  
 Chassis Assembly, S-Series, Manual 208-240V .....41  
 Chassis Assembly, S-Series, Manual 230V .....42  
 Chassis Assembly, 1000-S, Electronic 208V-240V .....43

Chassis Assembly, 1000-S, Electronic 230V .....44  
 Chassis Assembly, 1000-UP, Electronic 120V.....45  
 Chassis Assembly, 1000-UP, Electronic 208V-240V .....46  
 Chassis Assembly, 1000-UP, Electronic 230V .....47  
 Chassis Assembly, 1000-UP, Electronic Deluxe 2000W .....48  
 1000-S Slab Door Package "A", Reach-In .....49  
 1000-S Window Door Package "B", Reach-In .....50  
 1000-S Slab Door Package "C", Pass-Thru .....51  
 1000-S Slab Door Package "E", Reach-In (no vent covers).....52  
 1000-UP Slab Door Package "A", Reach-In .....53  
 1000-UP Window Door Package "B", Reach-In .....54  
 1000-UP Slab Door Package "C", Pass-Thru .....55  
 1000-UP Window Door Package "D", Pass-Thru .....56  
 Control Assembly, Single, Simple.....57  
 Control Assembly, Single, Deluxe with Probe.....58  
 Control Assembly, Single, Deluxe with Timer.....59  
 Control Assembly, Double, Deluxe .....60  
 Control Assembly, Double, Deluxe with Timer .....61  
 Control Assembly, Deluxe w/Timer .....62  
 Control Assembly, Deluxe .....63  
 Probe Assembly, Deluxe.....64  
 1000-S Side Rack and Shelves (Domestic).....65  
 1000-UP Proofer Pan Assembly.....66  
 Cordset/Ferrule Assembly, NEMA 5-15P .....67  
 Cordset/Ferrule Assembly, NEMA 5-20P .....68  
 Cord, 12/3 with Ferrules, 12' .....69  
 Cordset/Ferrule Assembly, SAA AS 3112-16P .....70  
 Cordset Assembly, AS/NZS 3112 .....71  
 Cordset Assembly, AS/NZS 3112 2000.....72  
 Cordset/Ferrule Assembly, NEMA 6-15P .....73  
 Cordset/Ferrule Assembly, CEE-7/7 .....74  
 Cordset/Ferrule Assembly, BS 1363.....75  
 Caster Package, 2-1/2" .....76  
 Caster Package, 2-1/2", All Swivel.....77  
 Caster Package, 3-1/2" .....78  
 Caster Package, 5" .....79  
 Caster Package, 5" (all swivel) .....80

## 1000-S Exterior Panel Package "A", Reach-In

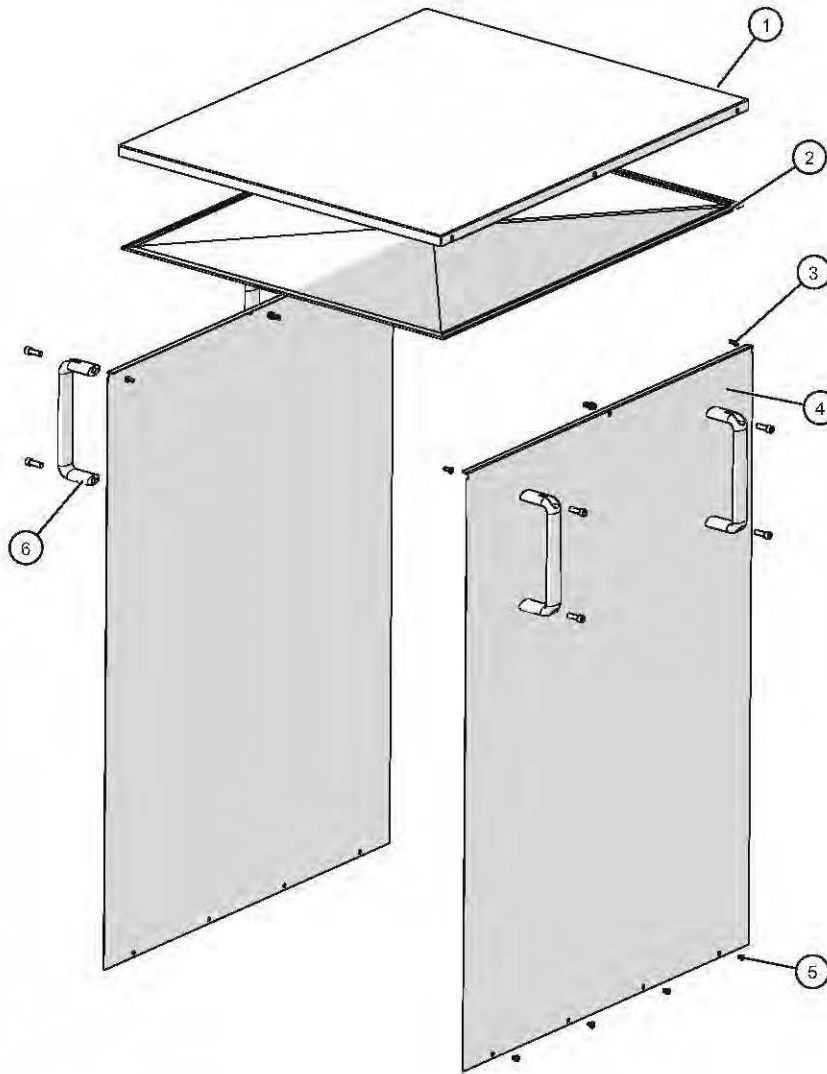

ID	Part No.	Description	Qty
1	1011534	BONNET TOP COVER 1000	1
2	GS-23622	GASKET, ADHESIVE, .125X.1/2" FOAM	1
3	SC-22273	SCREW, M4x0.7X10MM PAN	6
4	5015088R	1000 SERIES SS SIDE PANEL	2
5	SC-22271	SCREW, M4x0.7X6MM PAN	8
6	55662	PUSH/PULL HANDLE KIT (optional)	1

## 1000-S Exterior Panel Package "B", Pass-Thru

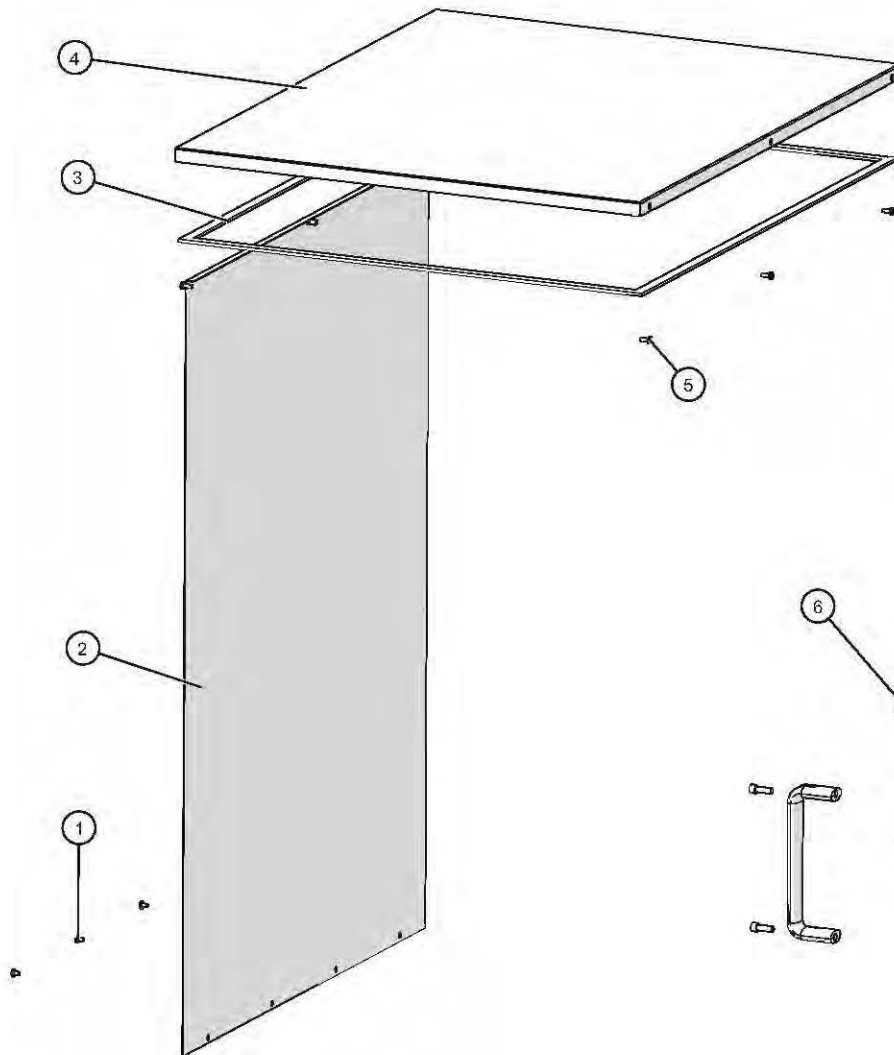

ID	Part No.	Description	Qty
1	SC-22271	SCREW, M4x0.7X6MM PAN	4
2	5015088	1000 SERIES SS SIDE PANEL SUBASSY	1
3	GS-23622	GASKETS, ADHESIVE, .125X.375 FOAM TAPE	1
4	1011534	BONNET TOP COVER 1000	1
5	SC-22273	SCREW, M4x0.7X10MM PAN	6
6	55662	PUSH/PULL HANDLE KIT (optional)	1

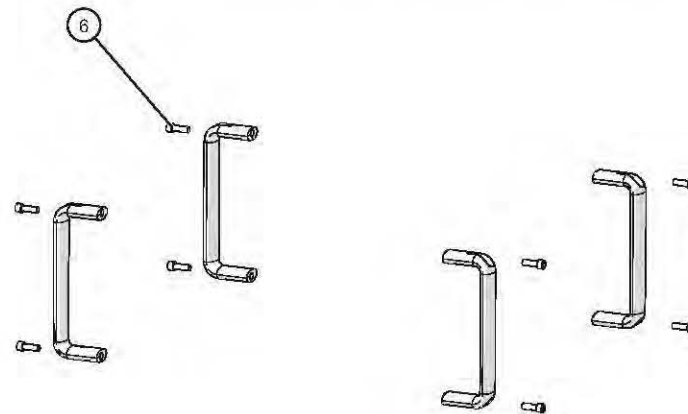

## 1000-UP Exterior Panel Package "A", Reach-In

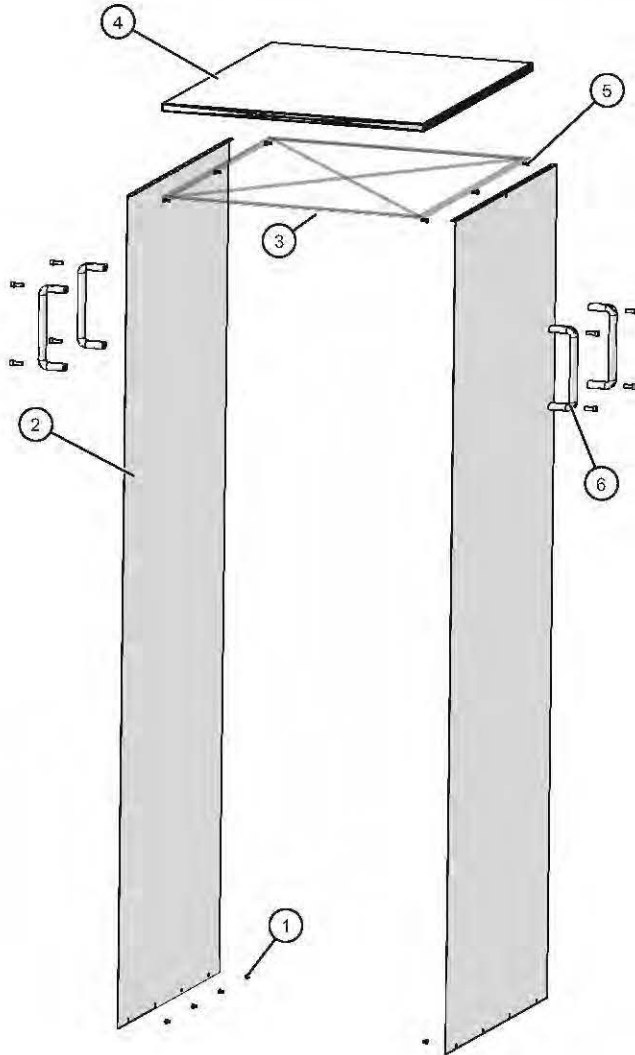

ID	Part No.	Description	Qty
1	SC-22271	SCREW,M4x0.7X6MM PAN	8
2	1011533	SIDE PANEL,1000/1200-UP	2
3	GS-23622	GASKET,ADHESIVE,.125X.1/2" FOAM TAPE	1
4	1011534	BONNET TOP COVER 1000	1
5	SC-22273	SCREW,M4x0.7X10MM PAN	6
6	55662	PUSH/PULL HANDLE KIT (optional)	1

## 1000-UP Exterior Panel Package "B", Pass-Thru

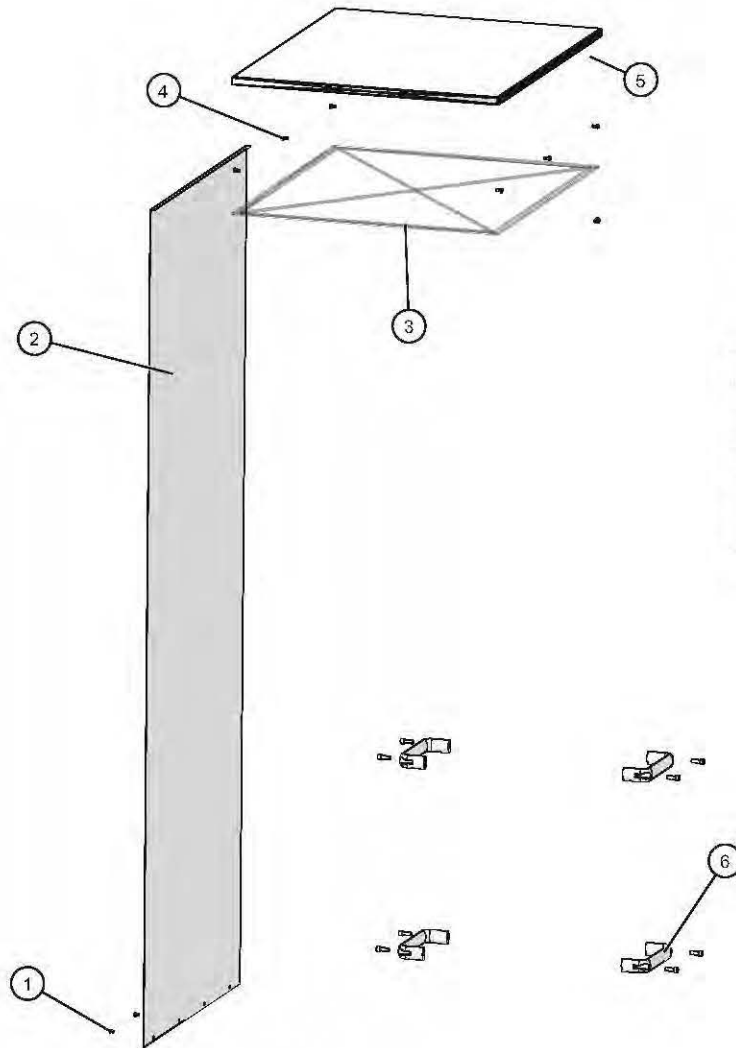

ID	Part No.	Description	Qty
1	SC-22271	SCREW,M4x0.7X6MM PAN	4
2	5015105R	1000/1200 SERIES S/S SIDE PANEL ASSY	1
3	GS-23622	GASKET, ADHESIVE,.125X 1/2" FOAM TAPE	1
4	SC-22273	SCREW,M4x0.7X10MM PAN	6
5	1011534	BONNET TOP COVER 1000	1
6	55662	PUSH/PULL HANDLE KIT (optional)	1

## 1000-UP Exterior Panel Package "C", Recessed Handles

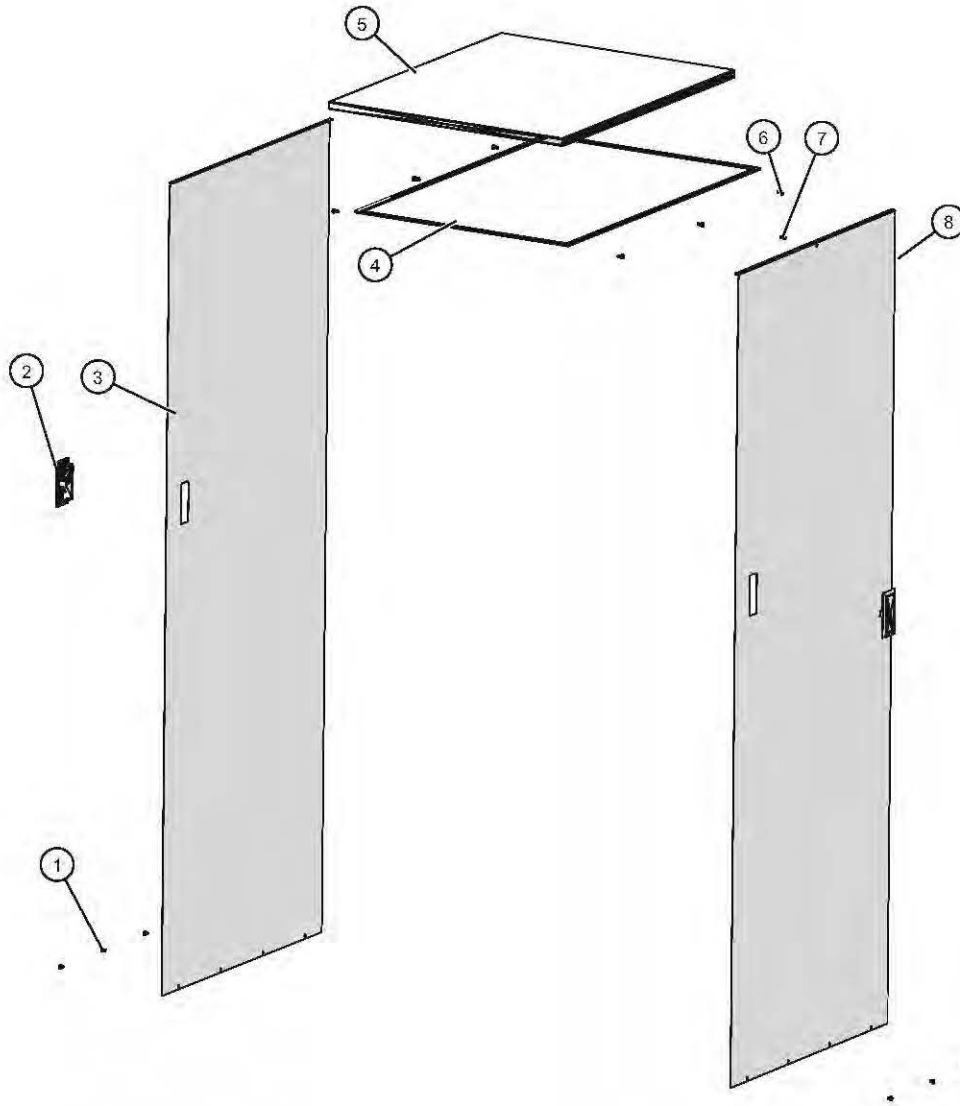

ID	Part No.	Description	Qty
1	SC-22271	SCREW,M4x0.7X6MM PAN	8
2	HD-28789	HANDLE, PULL RECESSED, BLACK	2
3	1034796	1000/1200 LH PANEL,W/HANDLE	1
4	GS-23622	GASKET, ADHESIVE,.125X.1/2" FOAM TAPE	1
5	1011534	BONNET TOP COVER 1000	1
6	SC-22273	SCREW,M4x0.7X10MM PAN	6
7	NU-26866	NUT, HEX INSERT M4	2
8	1034794	1000/1200 RH PANEL,W/HANDLE	1
9	55662	PUSH/PULL HANDLE KIT (optional)	1

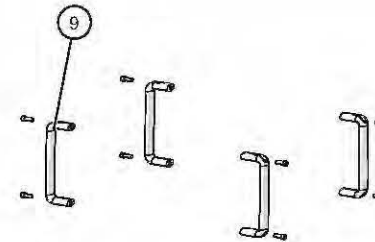

# 1000-S Core Assembly, Reach-In, Simple

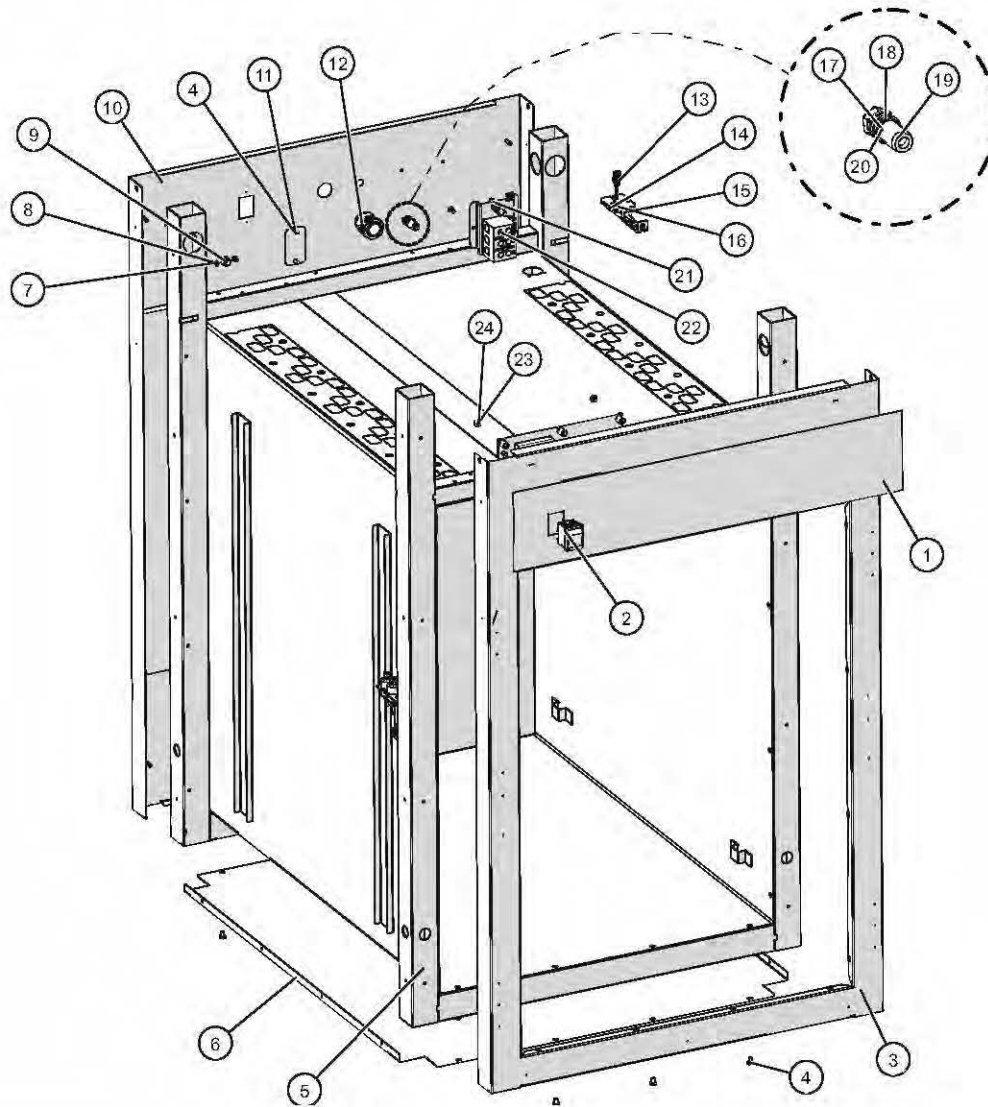

ID	Part No.	Description	Qty
1	PE-47892	OVERLAY, DISPLAY, ELAN '10	1
2	SW-38665	SWITCH,ROCKER,DPST,20A,125V,	1
3	5034517	TRIM,FRONT,SIMPLE,ASSEMBLY	1
4	SC-22271	SCREW,M4x0.7X6MM PAN	9
5	5014583	CAVITY PKG "A", REACH-IN	1
6	1009941	BOTTOM PANEL,1000-TH/I	1
7	5034318	MOUNTING CONTROL ASSY,SIMPLE	1
8	PG-28439	PLUG, DOME, .187" HOLE	2
9	PG-25574	3/8" HOLE PLUG	1
10	5034516	PANEL, BACK, REACH-IN, ASSEMBLY	1
11	1011697	BREAKER SWITCH CUTOFF COVER	1
12	BU-3964	BUSHING, STRAIGHT, STRAIN RELIEF	1
13	SN-47162	SENSOR, 1000 OHM, 40" WIRE,	1
14	SC-22271	M4 X 6MM PH PAN HD M/S .7	2
15	1493	GUARD SENSOR,W/MW	1
16	BK-29605	BLOCK, SENSOR, ELEC. CONTROL	1
17	WS-22302	WASHER, SPLIT LOCK, M6, 18-8 SST	4
18	WS-22297	WASHER, FLAT, M6, 18-8 SST	4
19	NU-22770	NUT, THREADED INSERT, M6	2
20	SC-22924	HHCS, M6 X 20, W/NO MARKING	2
21	RI-38125	RIVET, SEALED, .125"	2
22	5034317	CONTROL ASSY, SIMPLE, SINGLES	1
23	WS-23148	WASHER, 6-32, FLAT, NYL	4
24	NU-2361	NUT, 6-32 HEX, S/S	4

# 1000-S Core Assembly, Reach-In, Deluxe

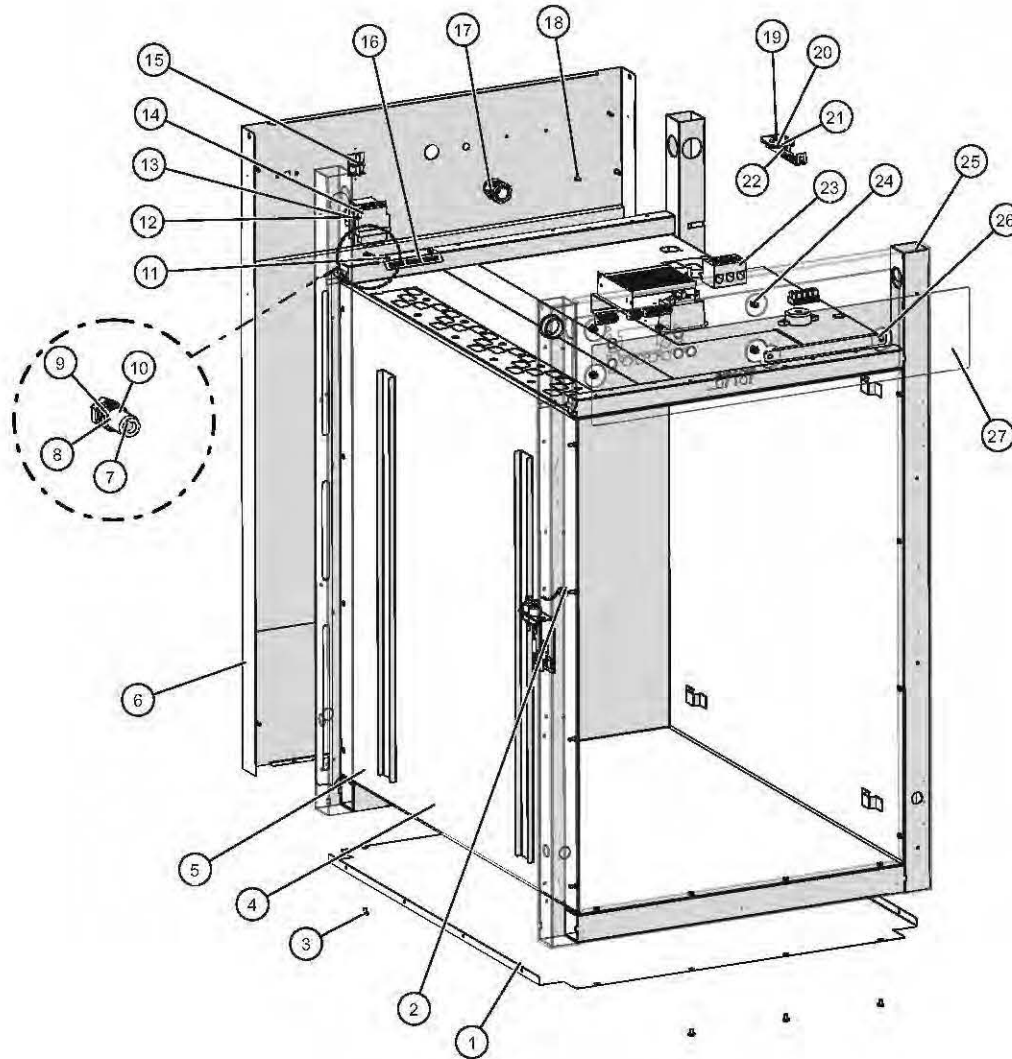

ID	Part No.	Description	Qty
1	1009941	BOTTOM PANEL, 1000-TH/I	1
2	5034314	SWITCH, REED, ASSEMBLY	1
3	SC-22271	SCREW, M4x0.7X6MM PAN	7
4	5014583	CAVITY PKG "A", REACH-IN	1
5	5012280	1000-S, INSULATION ASSEMBLY	1
6	5034516	PANEL, BACK, REACH-IN, ASSEMBLY	1
7	NU-22770	NUT, THREADED INSERT, M6	2
8	SC-22924	HHCS, M6 X 20, W/NO MARKING	2
9	WS-22302	WASHER, SPLIT LOCK, M6, 18-8 SST	4
10	WS-22297	WASHER, FLAT, M6, 18-8 SST	4
11	RI-27108	RIVET, SEALED, 0.125" x 0.45"	2
12	1003936	HI-LIMIT PROTECTION COVER	1
13	SC-22271	M4 X 6MM PH PAN HD M/S .7	2
14	TT-33476	THERMOSTAT, 300F HI-LIMIT	1
15	SW-38665	SWITCH, ROCKER, DPST, 20A, 125V,	1
16	1010119	HI-LIMIT BULB HOLDER	1
17	BU-3964	BUSHING, STRAIGHT, STRAIN RELIEF	1
18	RI-38125	RIVET, SEALED, .125", GRIP .039-.118	2
19	SN-38110	SENSOR, 100 OHM, 110" WIRE,	1
20	BK-29605	BLOCK, SENSOR, ELEC. CONTROL	1
21	SC-22271	M4 X 6MM PH PAN HD M/S .7	2
22	1493	GUARD SENSOR, W/MW	1
23	5034305	WARMER SERIES, DELUXE	1
24	NU-26526	NUT, #8-32 UNC KEPS ZP	4
25	5034548	TRIM ASSY, DX, FRONT	1
26	NU-2296	NUT, HEX #8-32	2
27	PE-27082	1000-S ELECTRONIC OVERLAY	1

# 1000-UP Core Assembly, Reach-In, Simple

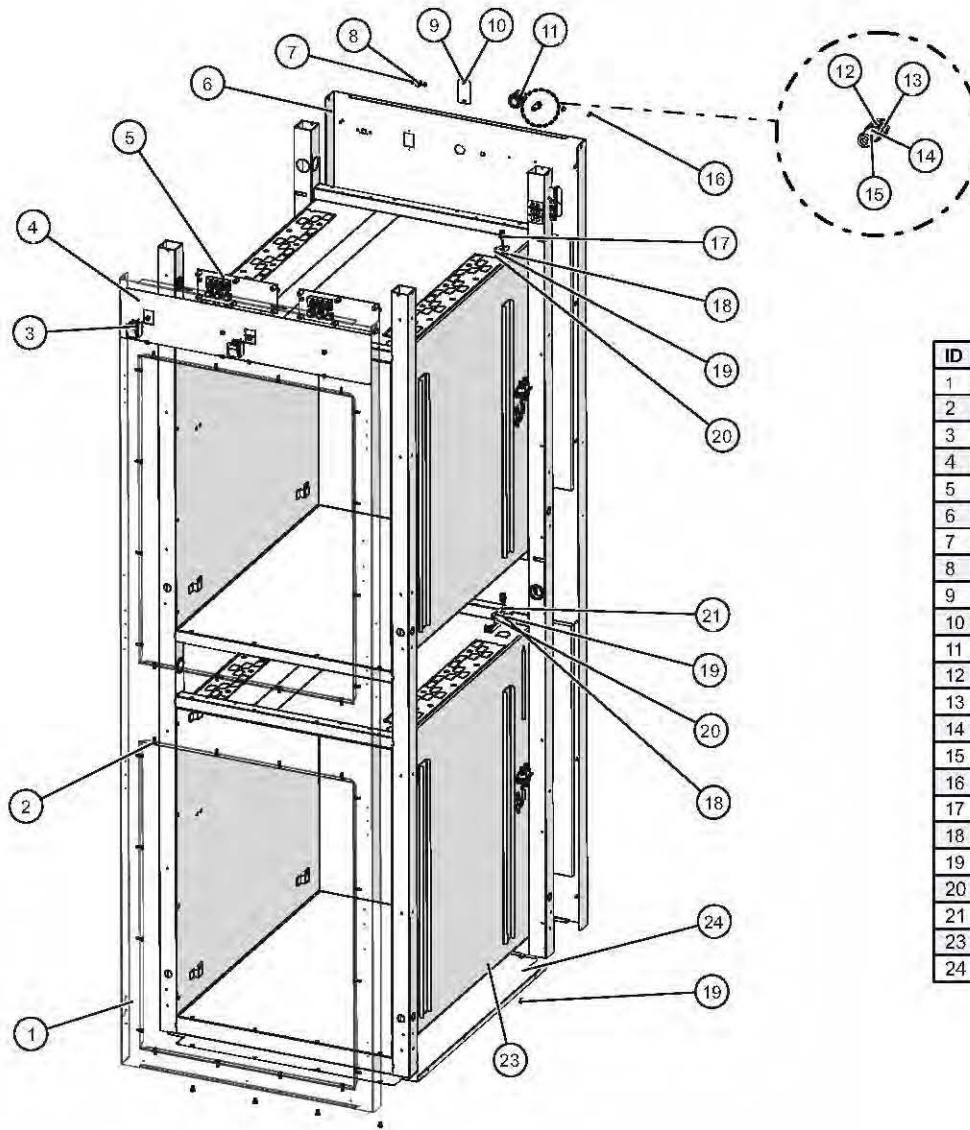

ID	Part No.	Description	Qty
1	5034583	TRIM,FRONT,SIMPLE,OVERLAY	1
2	RI-27108	RIVET, SEALED, 0.125" x 0.45"	44
3	SW-38665	SWITCH,ROCKER,DPST,20A,125V,	2
4	PE-47893	OVERLAY, DISPLAY, ELAN '10	1
5	5012553	CONTROL ASSY,SIMPLE,DOUBLES,	1
6	5034585	PANEL,BACK,REACH-IN,ASSY	1
7	PG-28439	PLUG, DOME,.187" HOLE	2
8	PG-25574	3/8" HOLE PLUG	1
9	SC-22271	SCREW, PAN HEAD M4 X 7MM	2
10	1011697	BREAKER SWITCH CUTOUT COVER	1
11	BU-3964	BUSHING,STRAIGHT,STRAIN RELIEF	1
12	WS-22297	WASHER, FLAT	2
13	SC-22924	HHCS, M6 X 20, W/NO MARKING	1
14	WS-22302	WASHER, SPLIT LOCK	2
15	NU-22770	NUT, THREADED INSERT, M6	1
16	RI-38125	RIVET,SEALED,.125", GRIP .039-.118	2
17	SN-47162	SENSOR, 1000 OHM, 40" WIRE,	1
18	BK-29605	BLOCK, SENSOR, ELEC. CONTROL	2
19	SC-22271	SCREW, PAN HEAD M4 X 7MM	12
20	1493	GUARD SENSOR,W/MW	2
21	SN-38111	SENSOR, 1000 OHM, 110" WIRE,	1
23	5014526	1000-UP CAVITY PKG"A" REACH-IN	1
24	1009941	BOTTOM PANEL,1000-TH/I	1

# 1000-UP Core Assembly, Reach-In, Deluxe

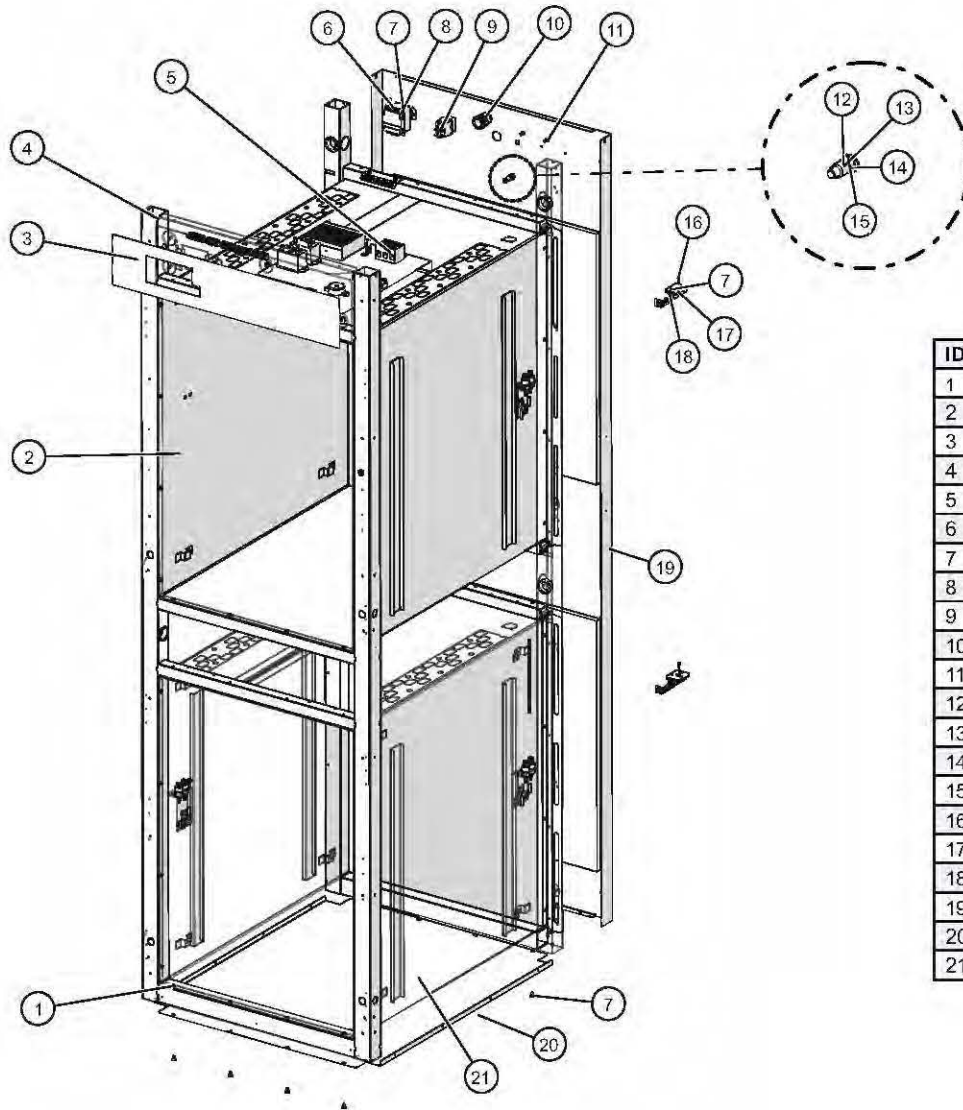

ID	Part No.	Description	Qty
1	RI-27108	RIVET, SEALED, 0.125" x 0.45"	48
2	5014526	1000-UP CAVITY PKG"A" REACH-IN	1
3	PE-27938	1000-UP ELECTRONIC CONTROL	1
4	5034607	TRIM,ELEC.FRONT,OVERLAY,ASSY	1
5	5034606	WARMER SERIES DELUXE DOUBLES,	1
6	1003936	HI-LIMIT PROTECTION COVER	1
7	SC-22271	SCREW, M4 X 6MM PH PAN HD M/S .7	14
8	TT-33476	THERMOSTAT, 300F HI-LIMIT	1
9	SW-38665	SWITCH,ROCKER,DPST,20A,125V,	1
10	BU-3964	BUSHING,STRAIGHT,STRAIN RELIEF	1
11	RI-38125	RIVET,SEALED,.125", GRIP .039-.118	2
12	WS-22302	WASHER, SPLIT LOCK, M6, 18-8 SST	2
13	NU-22770	NUT, THREADED INSERT, M6	1
14	SC-22924	HHCS, M6 X 20, W/NO MARKING	1
15	WS-22297	WASHER, FLAT, M6, 18-8 SST	2
16	SN-38110	SENSOR, 100 OHM, 110" WIRE,	2
17	BK-29605	BLOCK, SENSOR, ELEC. CONTROL	2
18	1493	GUARD SENSOR,W/MW	2
19	5034585	PANEL,BACK,REACH-IN,ASSY	1
20	1009941	BOTTOM PANEL,1000-TH/I	1
21	5012337	CABLE INSULATION 1000-UP	1

# 1000-UP Core Assembly, Pass-Thru, Simple

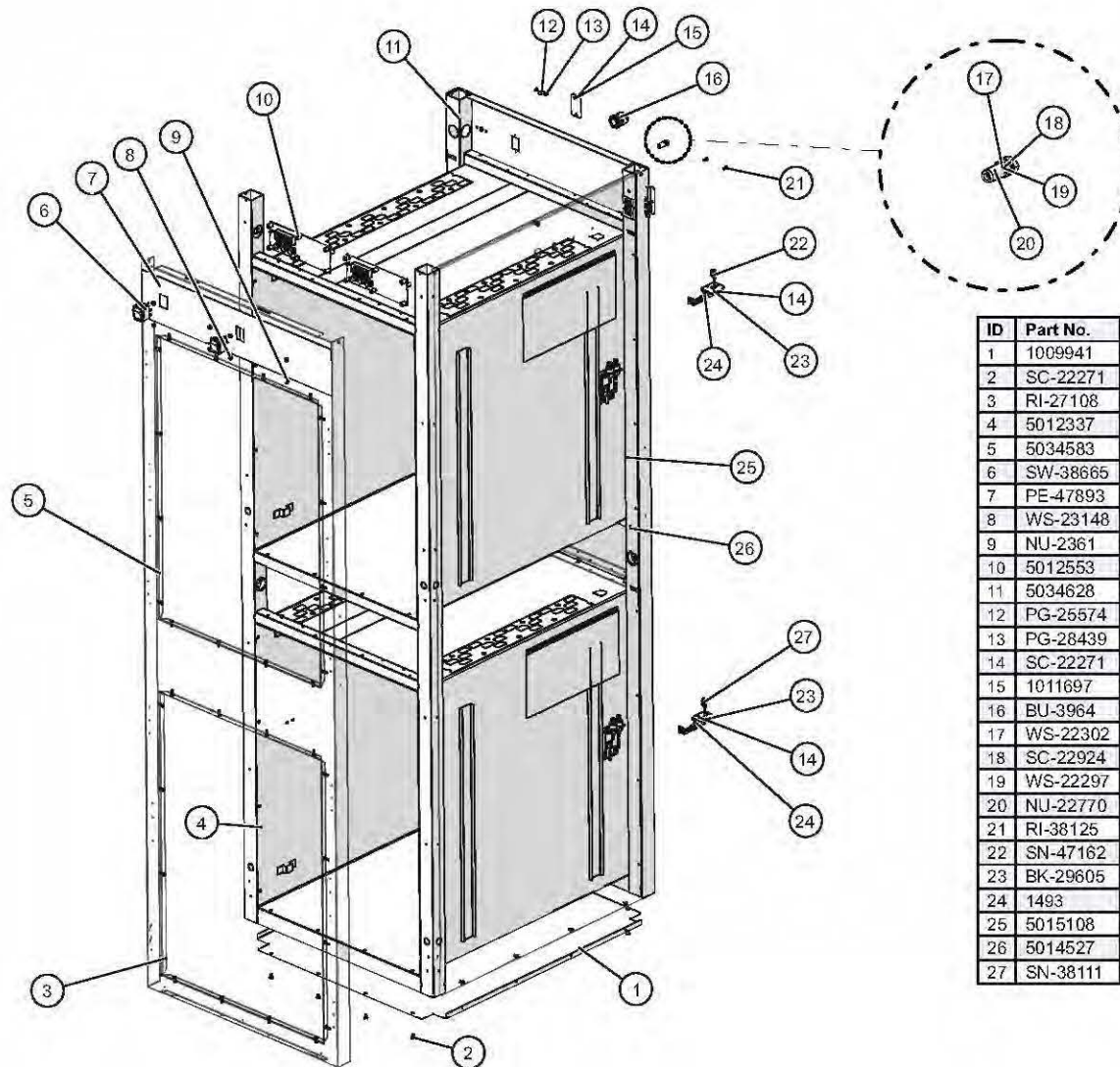

ID	Part No.	Description	Qty
1	1009941	BOTTOM PANEL, 1000-TH/I	1
2	SC-22271	SCREW, M4x0.7X6MM PAN	12
3	RI-27108	RIVET, SEALED, 0.125" x 0.45"	32
4	5012337	CABLE INSULATION 1000-UP	1
5	5034583	TRIM, FRONT, SIMPLE, OVERLAY	1
6	SW-38665	SWITCH, ROCKER, DPST, 20A, 125V,	2
7	PE-47893	OVERLAY, DISPLAY, ELAN '10	1
8	WS-23148	WASHER, 6-32, FLAT, NYL	8
9	NU-2361	NUT, 6-32 HEX, S/S	8
10	5012553	CONTROL ASSY, SIMPLE, DOUBLES,	1
11	5034628	TRIM ASSY, PASS-THRU, REAR	1
12	PG-25574	3/8" HOLE PLUG	1
13	PG-28439	PLUG, DOME, .187" HOLE	2
14	SC-22271	SCREW, PAN HEAD M4 X 7MM	6
15	1011697	BREAKER SWITCH CUTOFF COVER	1
16	BU-3964	BUSHING, STRAIGHT, STRAIN RELIEF	1
17	WS-22302	WASHER, SPLIT LOCK	2
18	SC-22924	HHCS, M6 X 20, W/NO MARKING	1
19	WS-22297	WASHER, FLAT	2
20	NU-22770	NUT, THREADED INSERT, M6	1
21	RI-38125	RIVET, SEALED, .125", GRIP .039-.118	2
22	SN-47162	SENSOR, 1000 OHM, 40" WIRE,	1
23	BK-29605	BLOCK, SENSOR, ELEC. CONTROL	2
24	1493	GUARD SENSOR, W/MW	2
25	5015108	1000/1200 SERIES SIDE PANEL	1
26	5014527	CAVITY, PKG"B"PASS-THRU	1
27	SN-38111	SENSOR, 1000 OHM, 110" WIRE,	1

# 1000-UP Core Assembly, Pass-Thru, Deluxe

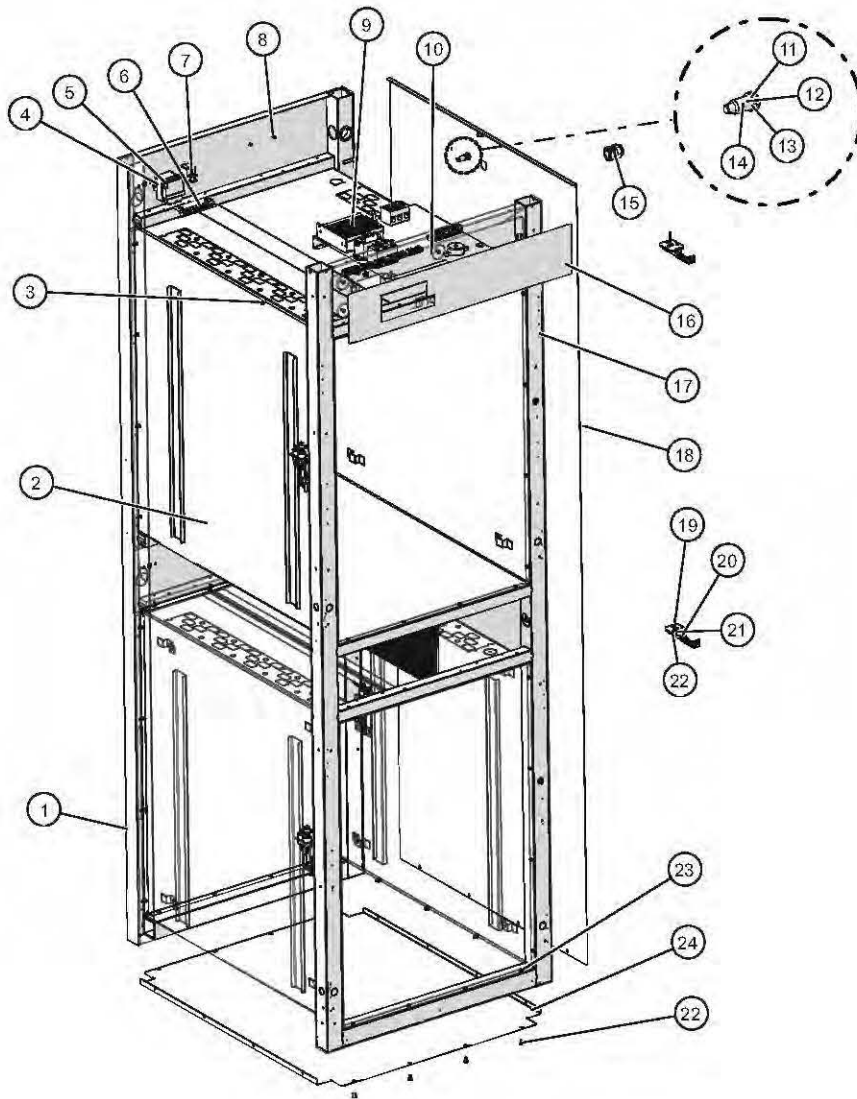

ID	Part No.	Description	Qty
1	5034628	TRIM ASSY,PASS-THRU,REAR	1
2	5012337	CABLE INSULATION 1000-UP	1
3	NU-26526	NUT, #8-32 UNC KEPS ZP	4
4	1003936	HI-LIMIT PROTECTION COVER	1
5	TT-33476	THERMOSTAT, 300F HI-LIMIT	1
6	1010119	HI-LIMIT BULB HOLDER	1
7	SW-38865	SWITCH,ROCKER,DPST,20A,125V,	1
8	RI-38125	RIVET,SEALED,.125", GRIP .039-.118	2
9	5034606	WARMER SERIES DELUXE DOUBLES,	1
10	NU-2296	NUT, HEX #8-32	2
11	WS-22297	WASHER, FLAT, M6, 18-8 SST	4
12	WS-22302	WASHER, SPLIT LOCK, M6, 18-8 SST	4
13	SC-22924	HHCS, M6 X 20, W/NO MARKING	2
14	NU-22770	NUT, THREADED INSERT, M6	2
15	BU-3964	BUSHING,STRAIGHT,STRAIN RELIEF	1
16	PE-27938	1000-UP ELECTRONIC CONTROL	1
17	5034607	TRIM,ELEC.FRONT,OVERLAY,ASSY	1
18	5015108	1000/1200 SERIES SS P/T	1
19	SN-38110	SENSOR, 100 OHM, 110" WIRE,	2
20	1493	GUARD SENSOR,W/MW	2
21	BK-29605	BLOCK, SENSOR, ELEC. CONTROL	2
22	SC-22271	SCREW, M4 X 6MM PH PAN HD M/S .7	12
23	RI-27108	RIVET, SEALED, 0.125" x 0.45"	34
24	1009941	BOTTOM PANEL,1000-TH/I	1

## Heating Wire Service Kits

Cable Heating Kit > (One kit required per compartment)		#4874 (500, 750, 1000)	#4881 (1200 - 4000W)	#4878 (1200 - all but 4000W)
Part No.	Description	Qty	Qty	Qty
CB-3045	Cable Heating Element	—	210 feet (6401cm)	90 feet (2591cm)
CB-3044	Cable Heating Element	120 feet (3658cm)	—	—
CR-3226	Ring Connector	4	12	4
IN-3488	Insulation Corner	1 foot (30,5cm)	1 foot (30,5cm)	1 foot (30,5cm)
BU-3105	Shoulder Bushing	4	12	4
BU-3106	Cup Bushing	4	12	4
ST-2439	Stud	4	12	4
NU-2215	Hex Nut	8	24	8
SL-3063	Insulating Sleeve	4	12	4
TA-3540	Electrical Tape	1 roll	1 roll	1 roll

For heating wire replacement instructions, scan the QR code below.



# 1000-S Cavity Package "A", Reach-In

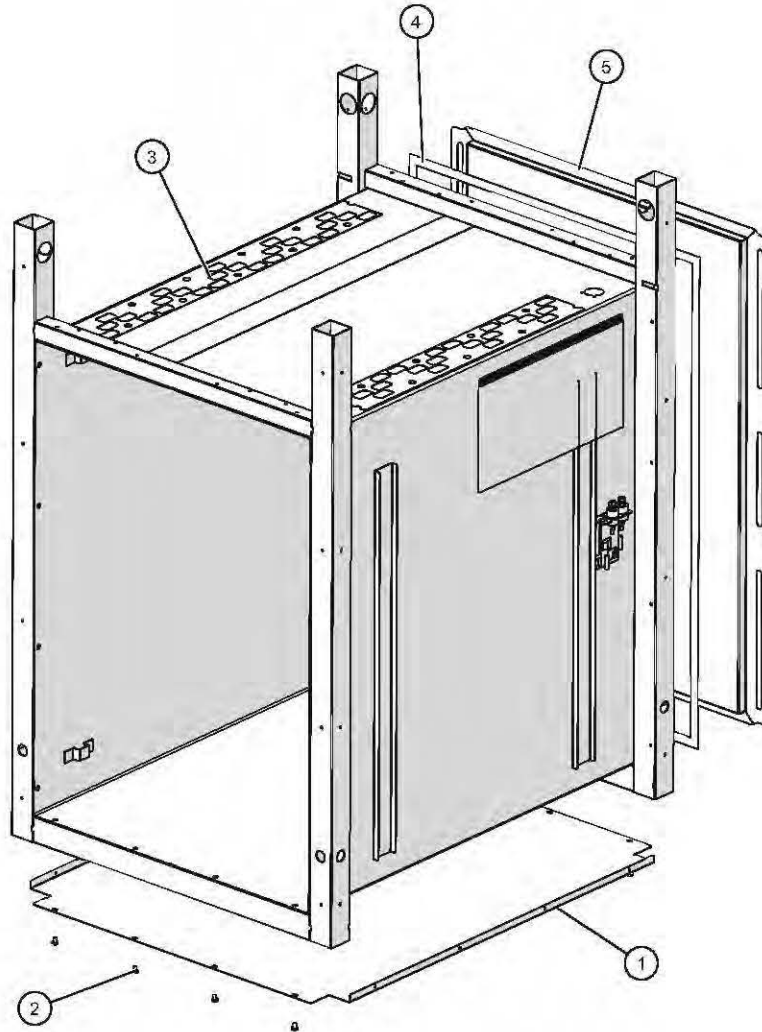

ID	Part No.	Description	Qty
1	1009941	BOTTOM PANEL, 1000-TH/I	1
2	SC-22271	SCREW, M4x0.7X6MM PAN	8
3	5012280	1000-S, INSULATION ASSEMBLY	1
4	TA-24637	.5" WIDE X 25 MIL VHB TAPE	1
5	1011529	1000-S/UP, INNER BACK PANEL	1

## 1000-S Cavity Package "B", Pass-Thru

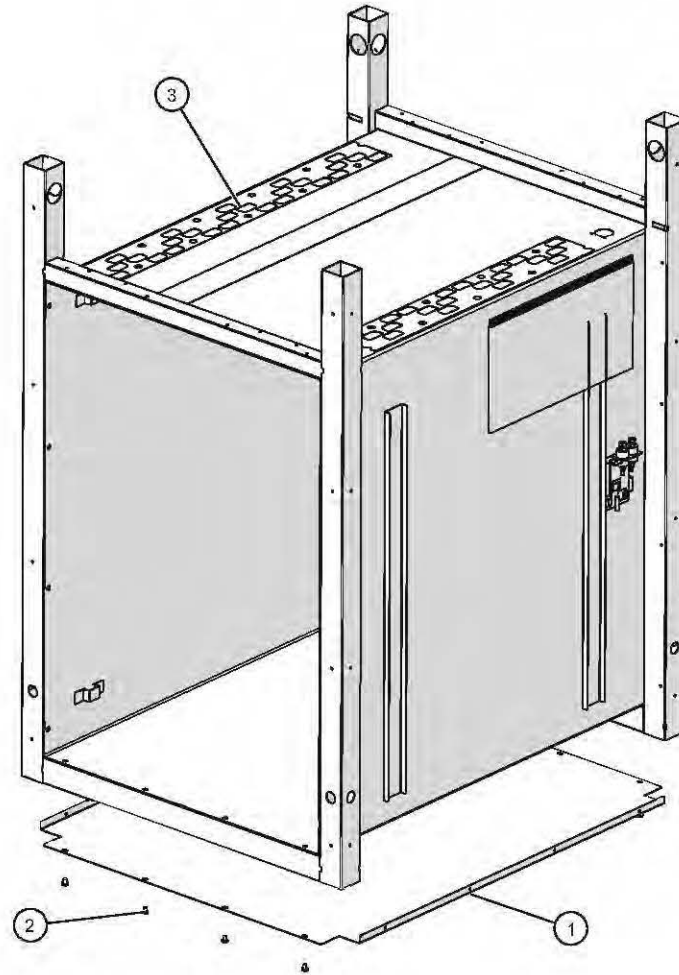

ID	Part No.	Description	Qty
1	1009941	BOTTOM PANEL,1000-TH/I	1
2	SC-22271	SCREW,M4x0.7X6MM PAN	8
3	5012280	1000-S, INSULATION ASSEMBLY	1

## 1000-UP Cavity Package "A", Reach-In

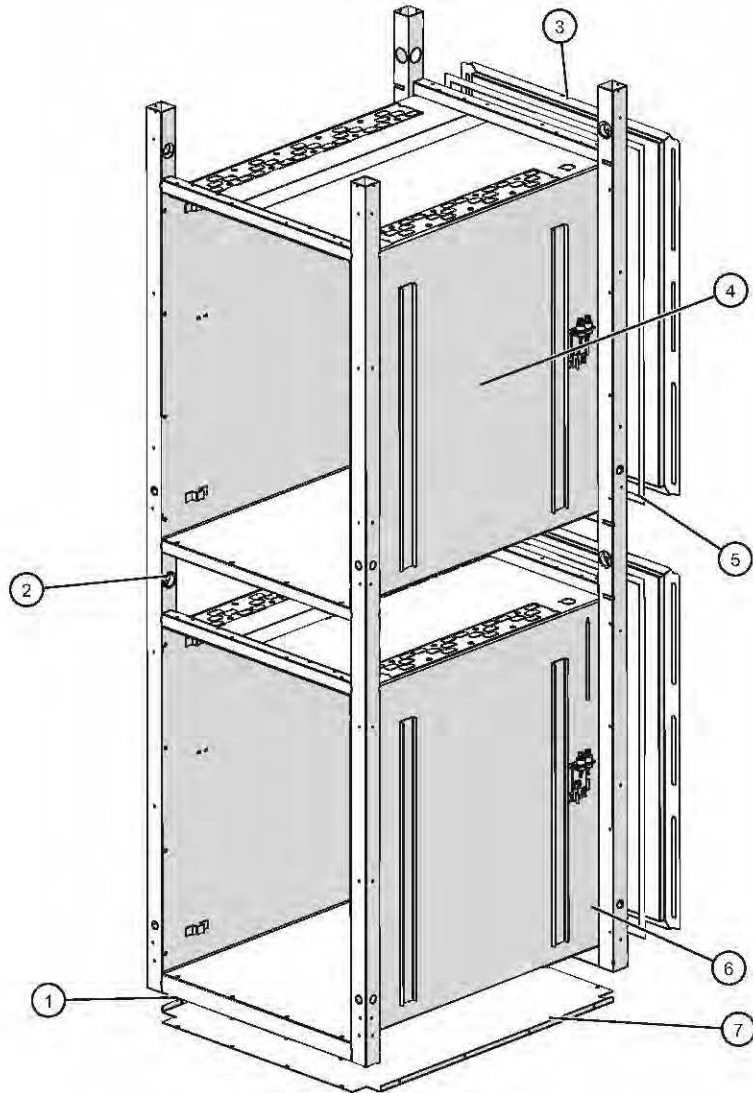

ID	Part No.	Description	Qty
1	SC-22271	M4 X 6MM PH PAN HD M/S .7	8
2	BU-3378	1 1/8" SNAP BUSHING	4
3	1011529	1000-S/UP, INNER BACK PANEL	2
4	1011528	1000-S/UP CAVITY, 2010	2
5	TA-24637	.5" WIDE X 25 MIL VHB TAPE	2
6	5012337	CABLE INSULATION 1000-UP	1
7	1009941	BOTTOM PANEL, 1000-TH/I	1

# 1000-UP Cavity Package "B", Pass-Thru

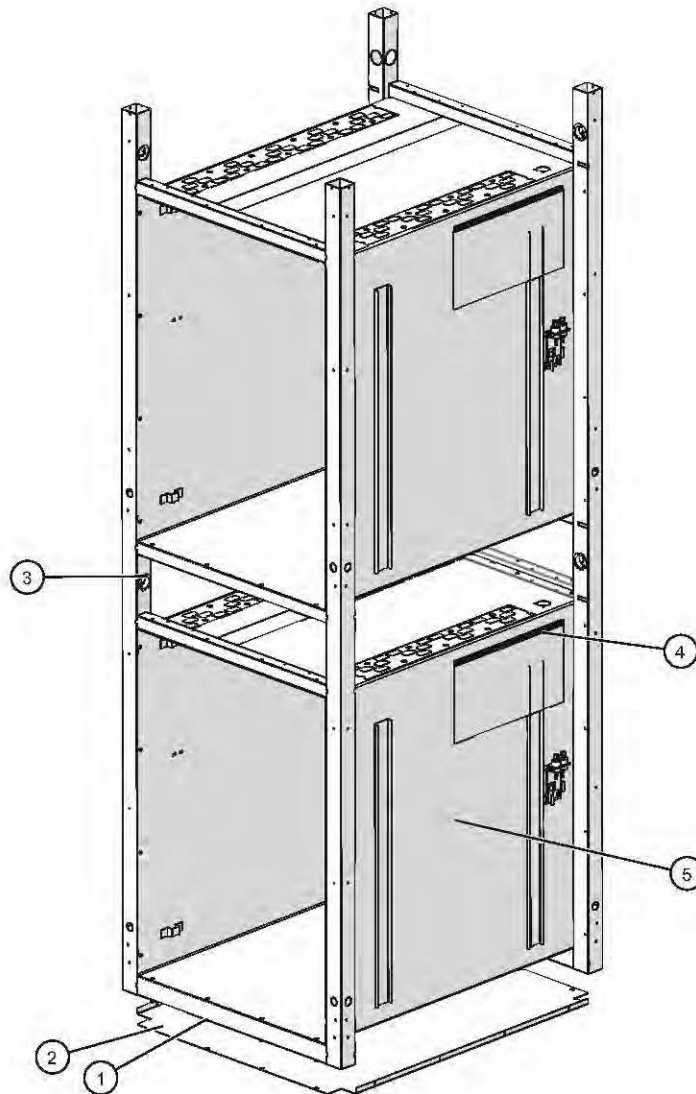

ID	Part No.	Description	Qty
1	SC-22271	M4 X 6MM PH PAN HD M/S .7	8
2	1009941	BOTTOM PANEL, 1000-TH/I	1
3	BU-3378	1 1/8" SNAP BUSHING	4
4	5012337	CABLE INSULATION 1000-UP	1
5	1011528	1000-S/UP CAVITY, 2010	2

## 1000-UP Cavity Package "C", Reach-In Proofer

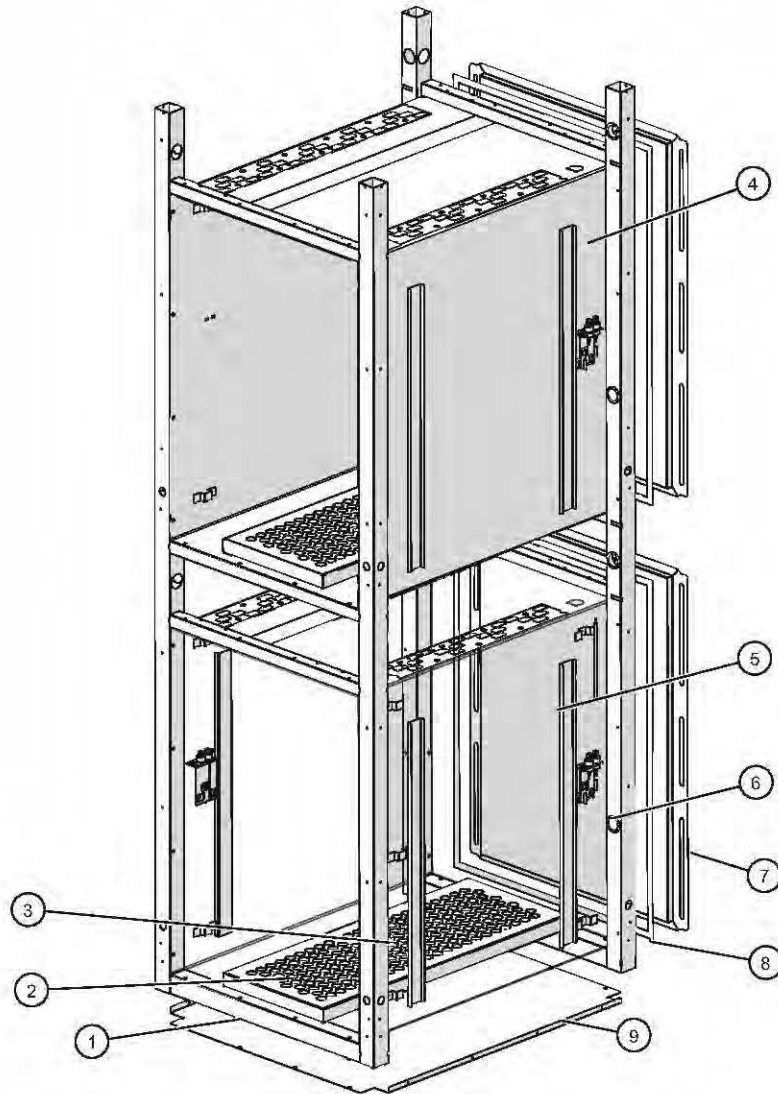

ID	Part No.	Description	Qty
1	SC-2459	8-32 x 1/4" PHIL SCREW	8
2	1775	MOISTURE PAN	2
3	1774	PAN COVER	2
4	5012337	CABLE INSULATION 1000-UP	1
5	1011528	1000-S/UP CAVITY, 2010	2
6	BU-3378	1 1/8" SNAP BUSHING	8
7	1011529	1000-S/UP, INNER BACK PANEL	2
8	TA-24637	.5" WIDE X 25 MIL VHB TAPE	2
9	1009941	BOTTOM PANEL, 1000-TH/I	1

## 1000-UP Cavity Package "D", Pass-Thru Proofer

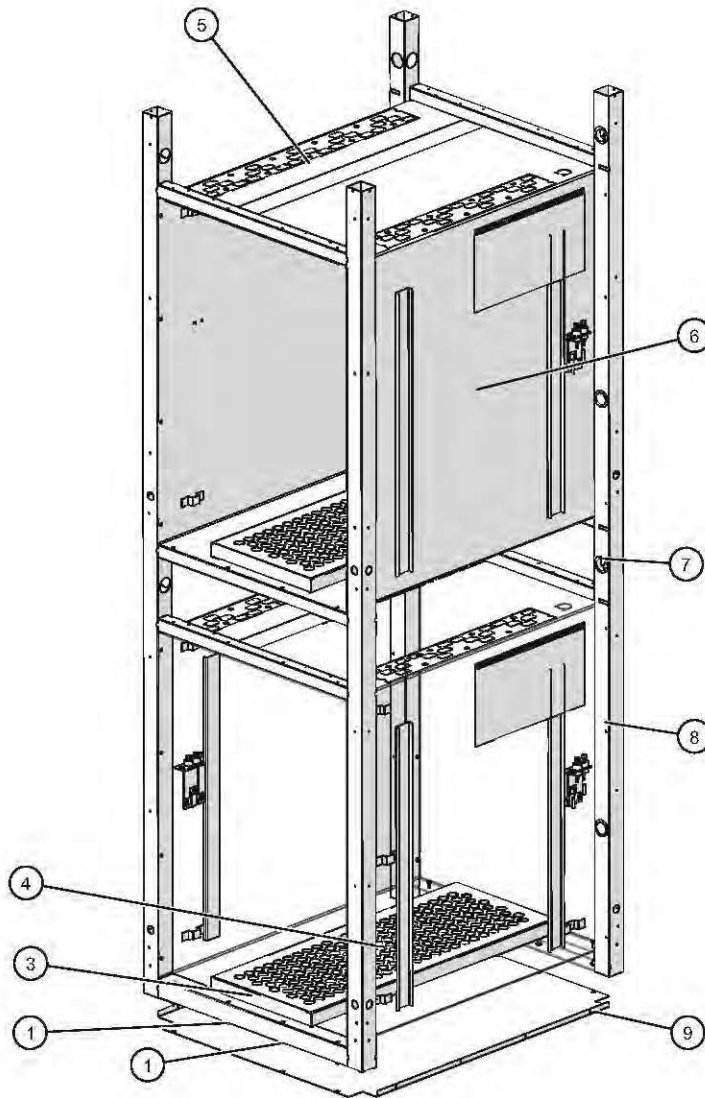

ID	Part No.	Description	Qty
1	SC-2459	8-32 x 1/4" PHIL SCREW	8
3	1775	MOISTURE PAN	2
4	1774	PAN COVER	2
5	5012337	CABLE INSULATION 1000-UP	1
6	1011528	1000-S/UP CAVITY, 2010	2
7	BU-3378	1 1/8" SNAP BUSHING	8
8	RI-27108	RIVET, SEALED	32
9	1009941	BOTTOM PANEL, 1000-TH/I	1

## Bumper Assembly (optional)

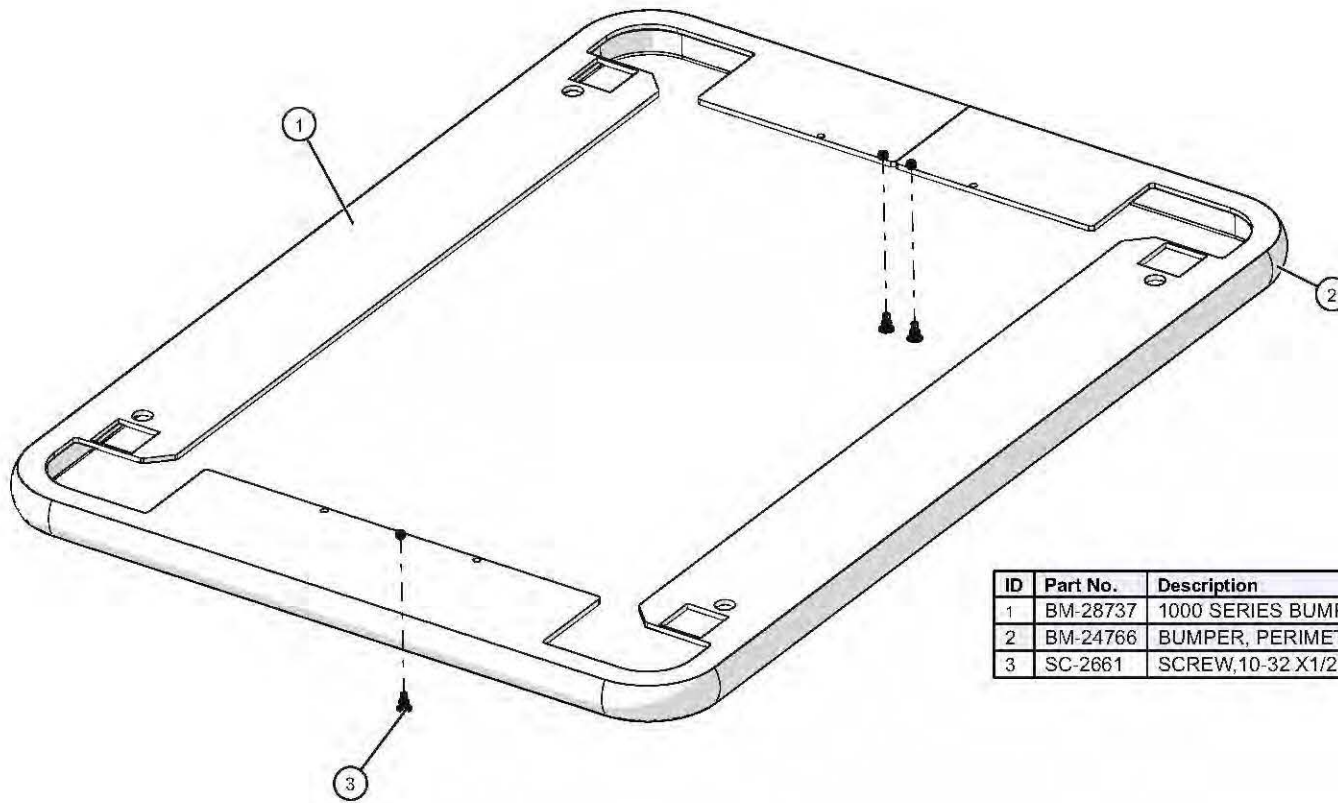

ID	Part No.	Description	Qty
1	BM-28737	1000 SERIES BUMPER	1
2	BM-24766	BUMPER, PERIMETER, RUBBER	1
3	SC-2661	SCREW,10-32 X1/2,NF PHIL TRUSS M/S,18-8 SS	3

# 1000-S Bonnet Package "A", Manual 120V

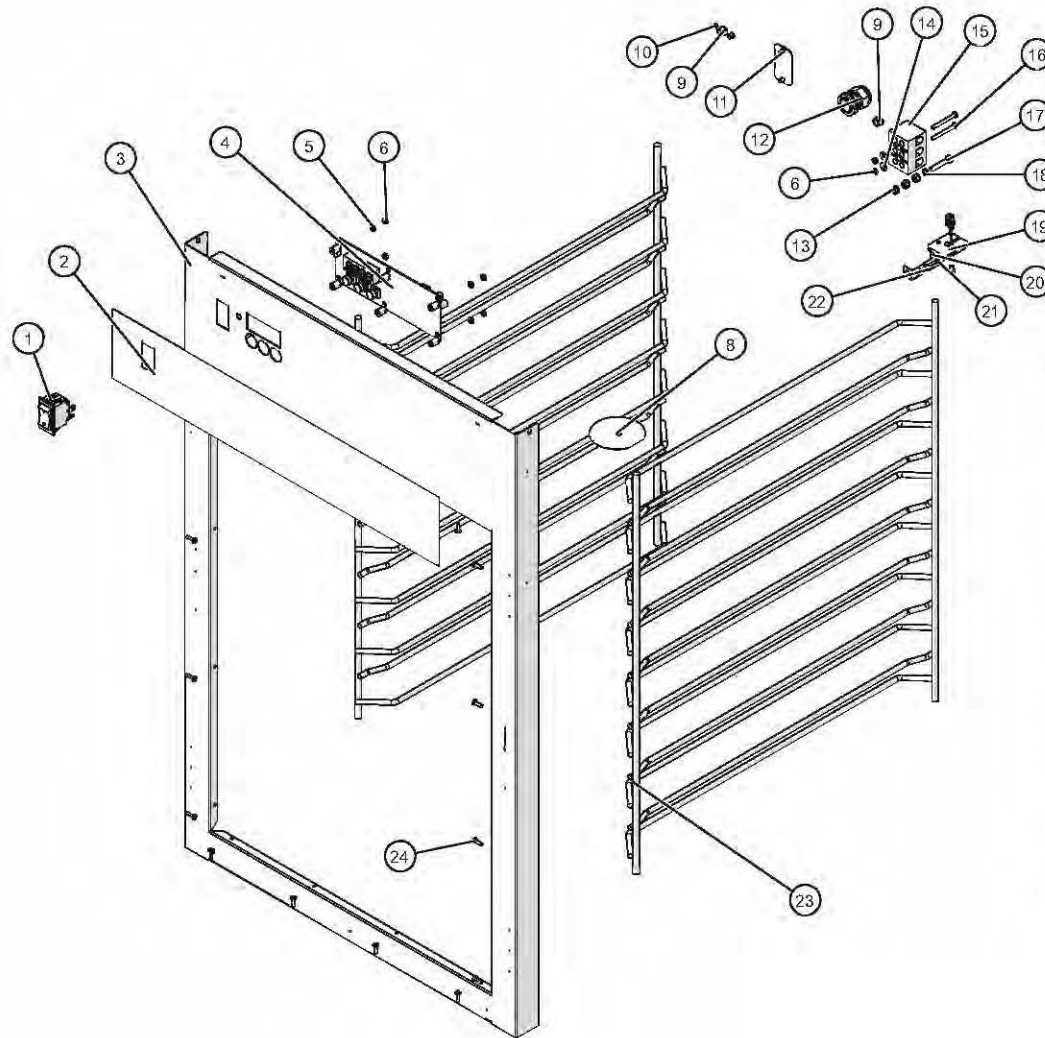

ID	Part No.	Description	Qty
1	SW-34769	SWITCH,ROCKER,125-277V,20A	1
2	PE-29396	PANEL, OVERLAY, 1000-S ELAN 2010	1
3	5012285	1000-S FRONT TRIM SPOT ASSB	1
4	5012587	ELEC CHASSIS, 1000/1200-S MANUAL 120V	1
5	WS-23148	WASHER, 6-32, FLAT, NYL	4
6	NU-2361	NUT, 6-32 HEX, S/S	6
8	1006871	NON-PRODUCT PROBE SEAL	1
9	PG-25574	3/8" HOLE PLUG	2
10	PG-28439	PLUG, DOME, .187" HOLE	2
11	1011697	BREAKER SWITCH CUTOFF COVER	1
12	BU-3964	BUSSING,STRAIGHT,STRAIN RELIEF	1
13	NU-36234	NUT, M5, KEPS	3
14	WS-23424	WASHER, FLAT, #8, 18-8 SST	2
15	BK-3019	T-BLOCK	1
16	SC-47136	SCREW,6-32X1-1/2" PAN	2
17	SC-38128	SCREW,PAN PH, METRIC, M5	1
18	WS-2467	WASHER, INT. LOCK	1
19	BK-29605	BLOCK, SENSOR, ELEC. CONTROL	1
20	1493	GUARD SENSOR,W/MW	1
21	SC-22271	SCREWS,M4-0.7X6MM PHIL	5
22	SN-38111	SENSOR, 1000 OHM, 110" WIRE,	1
23	SR-2120	1000-S,UP SIDE RACK	2
24	RI-27108	RIVET, SEALED	16

# 1000-S Bonnet Package "B", Manual 208V-240V

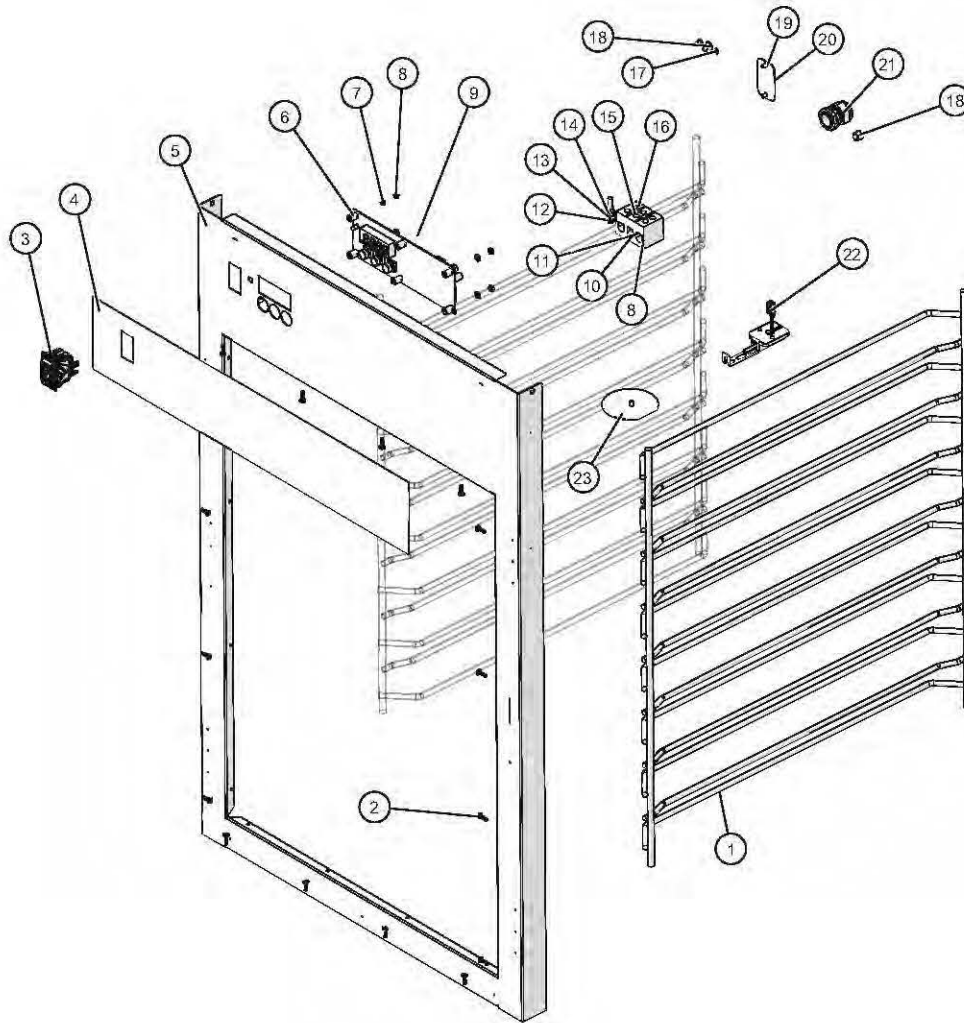

ID	Part No.	Description	Qty
1	SR-2120	1000-S,UP SIDE RACK	2
2	RI-27108	RIVET, SEALED	16
3	SW-34769	SWITCH,ROCKER,125-277V,20A	1
4	PE-29396	PANEL, OVERLAY, 1000-S ELAN 2010	1
5	5012285	1000-S ELAN CONTROL	1
6	SP-29392	SPACER, SNAP-IN, 7/16"	6
7	WS-23148	WASHER, 6-32, FLAT, NYL	4
8	NU-2361	NUT, 6-32 HEX, S/S	6
9	5012588	1000/1200-S MANUAL 208/240V,	1
10	WS-23424	WASHER, FLAT, #8, 18-8 SST	2
11	WS-22300	WASHER, SPLIT LOCK	2
12	WS-2467	WASHER, INT. LOCK	1
13	SC-38128	SCREW,PAN PH, METRIC, M5	1
14	NU-36234	NUT, M5, KEPS	3
15	SC-47136	SCREW,6-32X1-1/2" PAN	2
16	BK-3019	T-BLOCK	1
17	PG-28439	PLUG, DOME,,187" HOLE	2
18	PG-25574	3/8" HOLE PLUG	2
19	SC-22271	SCREWS,M4-0.7X6MM PHIL	3
20	1011697	BREAKER SWITCH CUTOUT COVER	1
21	BU-3964	BUSHING,STRAIGHT,STRAIN RELIEF	1
22	SN-38111	SENSOR, 1000 OHM, 110" WIRE,	1
23	1006871	NON-PRODUCT PROBE SEAL	1

# 1000-S Bonnet Package "C", Manual 230V

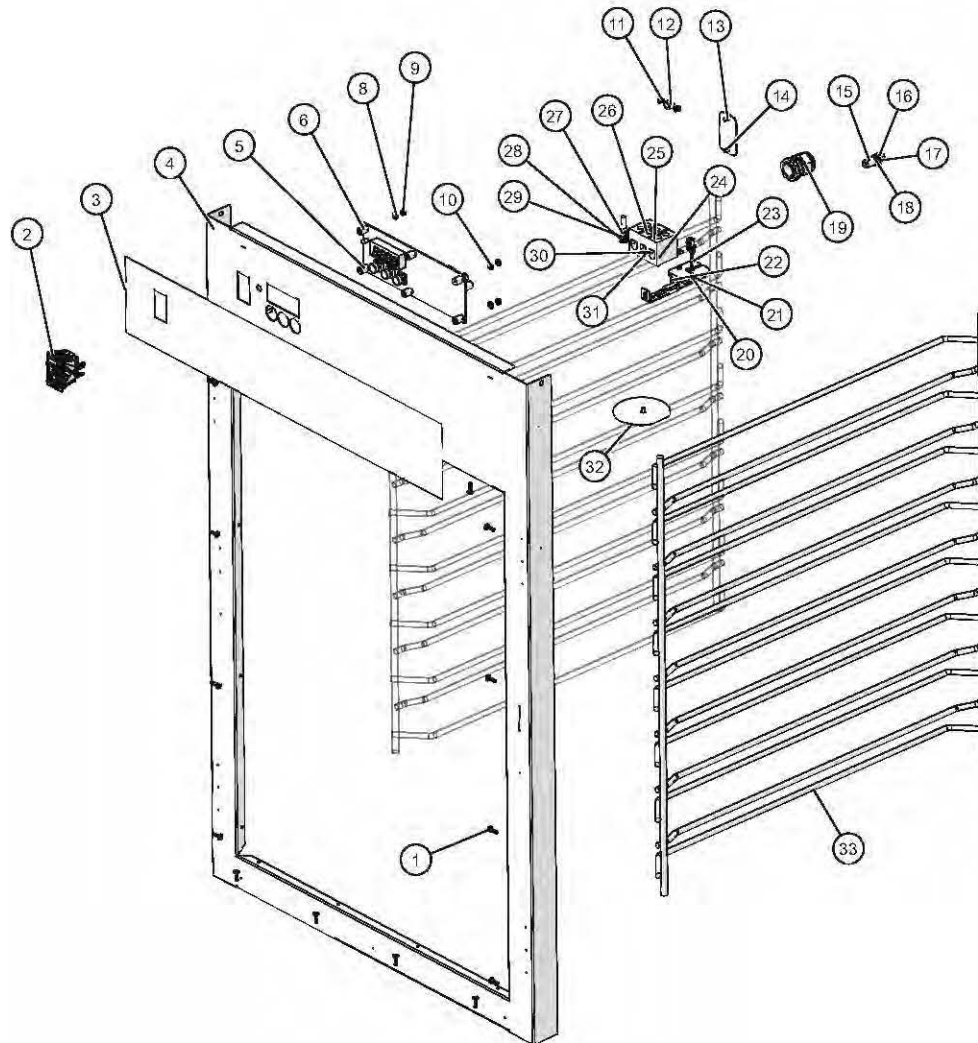

ID	Part No.	Description	Qty
1	RI-27108	RIVET, SEALED, 0.125" x 0.45"	16
2	SW-34769	SWITCH,ROCKER,125-277V,20A	1
3	PE-29396	PANEL, OVERLAY, 1000-S ELAN 2010	1
4	5012285	1000-S FRONT TRIM SPOT ASSB	1
5	5012589	ELEC CHASSIS MANUAL 230V	1
6	SP-29392	SPACER, SNAP-IN, 7/16"	1
8	WS-23148	WASHER, 6-32, FLAT, NYL	1
9	NU-2361	NUT, 6-32 HEX, S/S	1
10	WS-23148	WASHER, 6-32, FLAT, NYL	3
11	PG-28439	PLUG, DOME, 187° HOLE	2
12	PG-25574	3/8" HOLE PLUG	1
13	1011697	BREAKER SWITCH CUTOFF COVER	1
14	SC-22271	SCREWS,M4-0.7X6MM PHIL	3
15	NU-22770	NUT, THREADED INSERT, M6	1
16	WS-22297	WASHER, FLAT, M6, 18-8 SST	2
17	SC-22924	HHCS, M6 X 20, W/NO MARKING	1
18	WS-22302	WASHER, SPLIT LOCK, M6, 18-8 SST	2
19	BU-3964	BUSHING,STRAIGHT,STRAIN RELIEF	1
20	SC-22271	SCREWS,M4-0.7X6MM PHIL	2
21	BK-29605	BLOCK, SENSOR, ELEC. CONTROL	1
22	1493	GUARD SENSOR,W/MW	1
23	SN-38111	SENSOR, 1000 OHM, 110° WIRE,	1
24	WS-22300	WASHER, SPLIT LOCK, M4, 18-8 SST	2
25	BK-3019	T-BLOCK	1
26	SC-47136	SCREW,6-32X1-1/2" PAN	2
27	NU-36234	NUT, M5, KEPS	3
28	WS-2467	WASHER, INT. LOCK	1
29	SC-38128	SCREW,PAN PH, METRIC, M5	1
30	NU-2361	NUT, 6-32 HEX, S/S	5
31	WS-23424	WASHER, FLAT, #8, 18-8 SST	2
32	1006871	NON-PRODUCT PROBE SEAL	1
33	SR-2120	1000-S,UP SIDE RACK	2

# 1000-S Bonnet Package "D", Electronic Control 120V

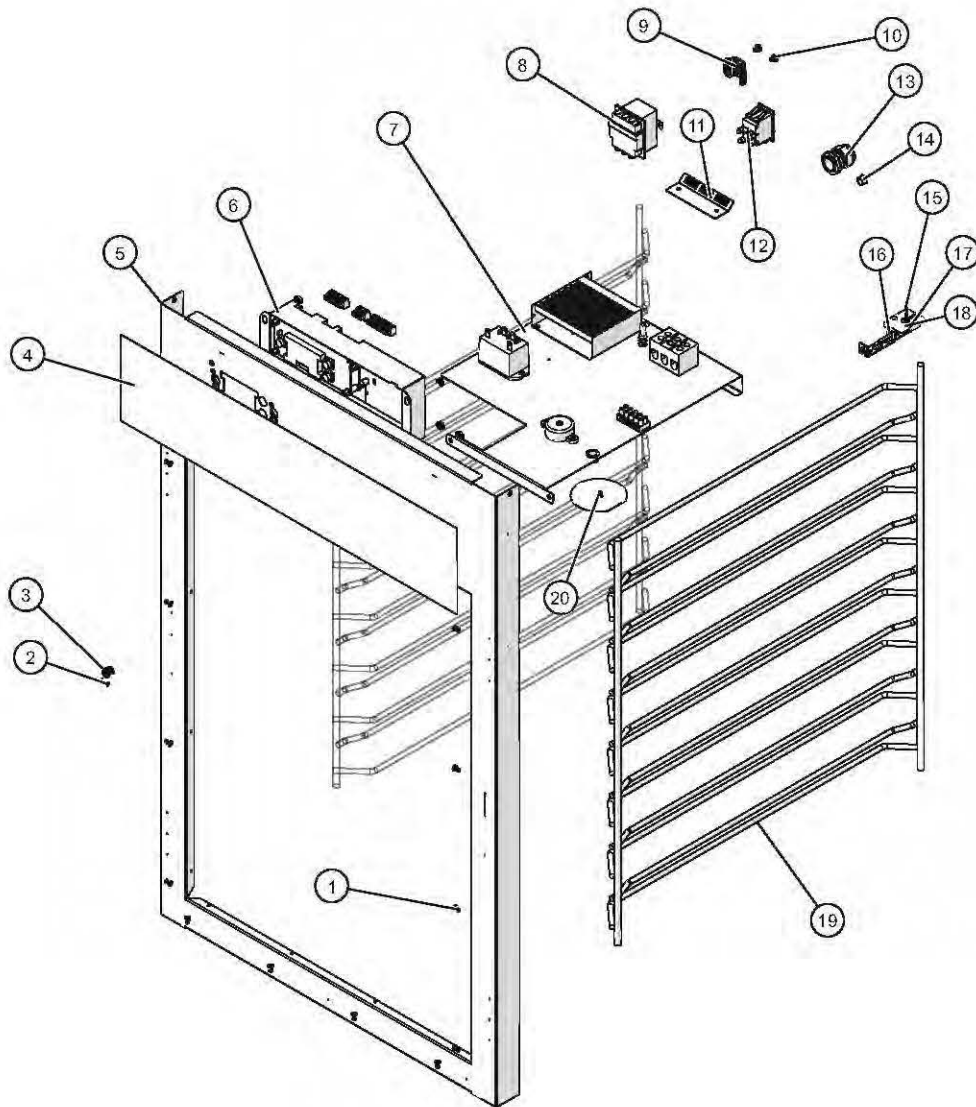

ID	Part No.	Description	Qty
1	RI-2100	RIVET,BLIND,#44,STNLS	16
2	SW-33559	SWITCH, REED, SPST	1
3	BU-3419	3/8" BLACK HOLE BUSHING	1
4	PE-27082	1000-S ELECTRONIC OVERLAY	1
5	5012609	1000-UP ELEC FRONT TRIM ASSY	1
6	CC-34322	ELECTRONIC WARMER CONTROL	1
7	5012604	WARMER SERIES ELEC 120V,	1
8	TT-33476	THERMOSTAT, 300F HI-LIMIT	1
9	1003936	HI-LIMIT PROTECTION COVER	1
10	SC-22271	SCREWS,M4-0.7X6MM PHIL	2
11	1010119	HI-LIMIT BULB HOLDER	1
12	SW-34769	SWITCH,ROCKER,125-277V,20A	1
13	BU-3964	BUSHING,STRAIGHT,STRAIN RELIEF	1
14	PG-25574	3/8" HOLE PLUG	1
15	SN-38110	SENSOR, 100 OHM, 110" WIRE,	1
16	1493	GUARD SENSOR,W/MW	1
17	SC-22271	SCREW,M4x0.7X6MM PAN	2
18	BK-29605	BLOCK, SENSOR, ELEC. CONTROL	1
19	SR-2120	1000-S,UP SIDE RACK	2
20	1006871	NON-PRODUCT PROBE SEAL	1

# 1000-S Bonnet Package "E", Electronic Control 208V-240V

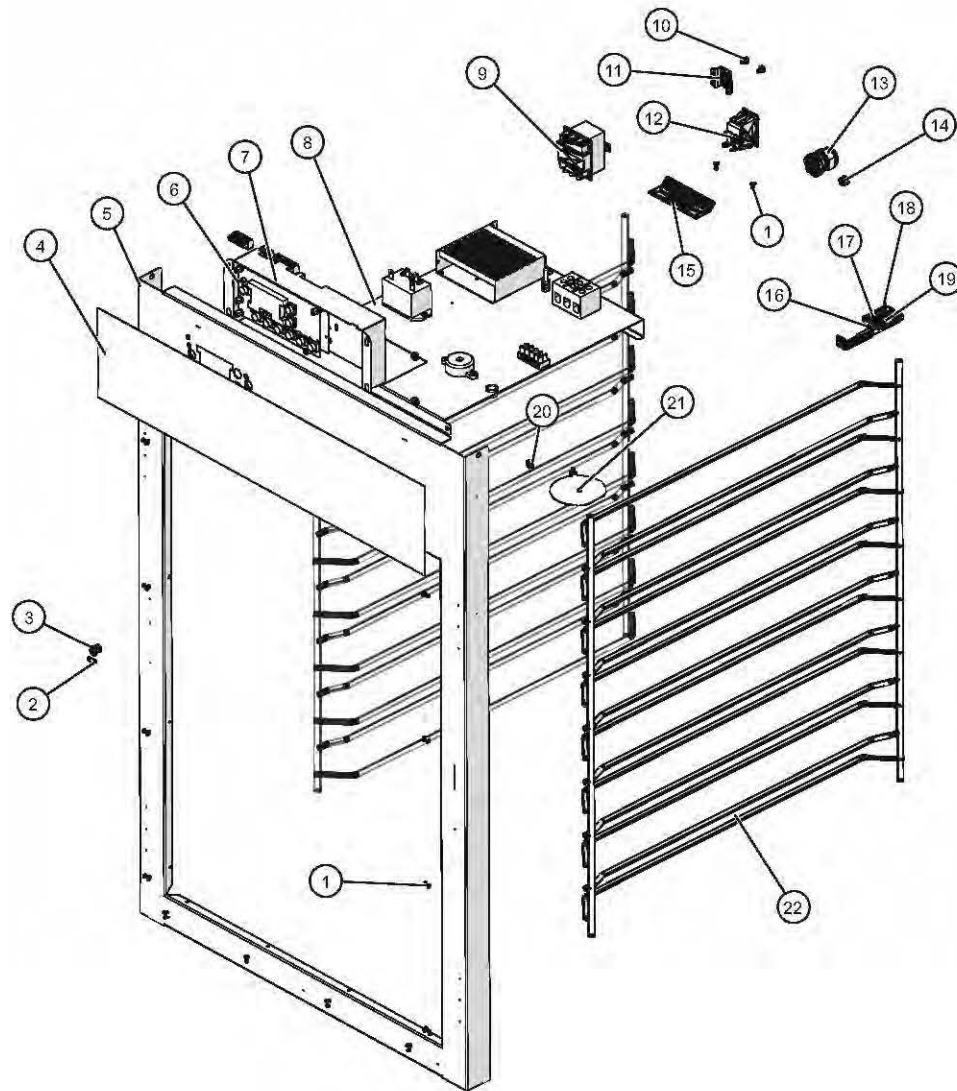

ID	Part No.	Description	Qty
1	RI-2100	RIVET,BLIND,#44,STNLS	18
2	SW-33559	SWITCH, REED, SPST	1
3	BU-3419	3/8" BLACK HOLE BUSHING	1
4	PE-27082	1000-S ELECTRONIC OVERLAY	1
5	5012609	1000-UP ELEC FRONT TRIM ASSY	1
6	CC-34324	CONTROL ASSY W/TIMERS	1
7	NU-26526	NUT, #8-32 UNC KEPS ZP	4
8	5012605	1000-S ELEC CHASSIS 208/240V	1
9	TT-33476	THERMOSTAT, 300F HI-LIMIT	1
10	SC-22271	SCREWS, M4-0.7X6MM PHIL	3
11	1003936	HI-LIMIT PROTECTION COVER	1
12	SW-34769	SWITCH,ROCKER,125-277V,20A	1
13	BU-3964	BUSHING, STRAIGHT, STRAIN RELIEF	1
14	PG-25574	3/8" HOLE PLUG	1
15	1010119	HI-LIMIT BULB HOLDER	1
16	1493	GUARD SENSOR, W/MW	1
17	SC-22271	SCREW, M4x0.7X6MM PAN	2
18	SN-38110	SENSOR, 100 OHM, 110" WIRE,	1
19	BK-29605	BLOCK, SENSOR, ELEC. CONTROL	1
20	NU-2296	NUT, HEX #8-32	2
21	1006871	NON-PRODUCT PROBE SEAL	1
22	SR-2120	1000-S,UP SIDE RACK	2

## 1000-S Bonnet Package "G", Electronic Control w/Timer 120V

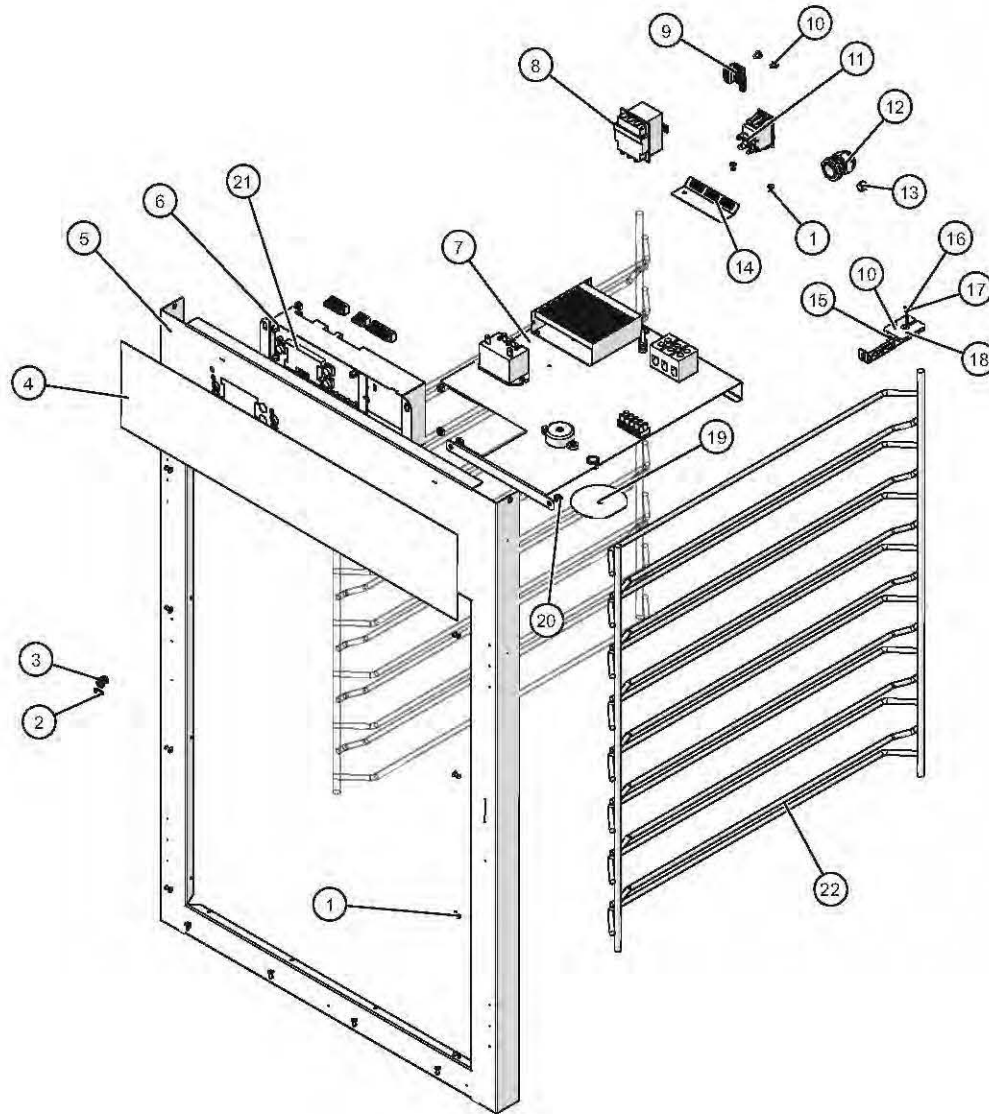

ID	Part No.	Description	Qty
1	RI-2100	RIVET,BLIND,#44,STNLS	18
2	SW-33559	SWITCH, REED, SPST	1
3	BU-3419	3/8" BLACK HOLE BUSHING	1
4	PE-26714	1000-S ELECTRONIC OVERLAY	1
5	5012609	1000-UP ELEC FRONT TRIM ASSY	1
6	CC-34324	ELEC WARMER CONTROL W/ TIMER	1
7	5012604	ELEC CHASSIS, 120V	1
8	TT-33476	THERMOSTAT, 300F HI-LIMIT	1
9	1003936	HI-LIMIT PROTECTION COVER	1
10	SC-22271	SCREW	5
11	SW-34769	SWITCH,ROCKER,125-277V,20A	1
12	BU-3964	BUSHING,STRAIGHT,STRAIN RELIEF	1
13	PG-25574	3/8" HOLE PLUG	1
14	1010119	HI-LIMIT BULB HOLDER	1
15	1493	GUARD SENSOR,W/MW	1
16	SN-38110	SENSOR, 100 OHM, 110" WIRE,	1
17	CR-33625	CONNECTOR, FERRULE #20	2
18	BK-29605	BLOCK, SENSOR, ELEC. CONTROL	1
19	1006871	NON-PRODUCT PROBE SEAL	1
20	NU-2296	NUT, HEX #8-32	2
21	NU-26526	NUT, #8-32 UNC KEPS ZP	4
22	SR-2120	1000-S,UP SIDE RACK	2

# 1000-S Bonnet Package "I", Electronic Control w/Timer 230V

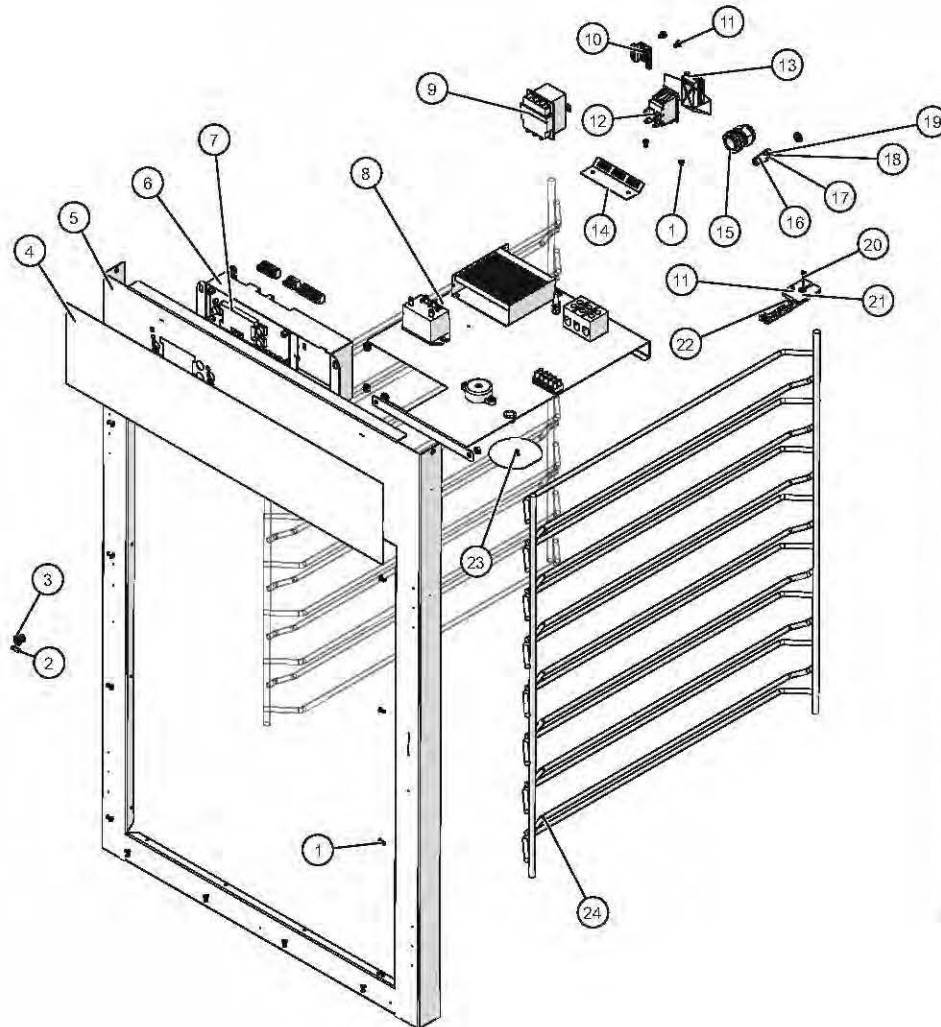

ID	Part No.	Description	Qty
1	RI-2100	RIVET,BLIND,#44,STNLS	3
2	SW-33559	SWITCH, REED, SPST	1
3	BU-3419	3/8" BLACK HOLE BUSHING	1
4	PE-26714	1000-S ELECTRONIC OVERLAY	1
5	5012609	1000-UP ELEC FRONT TRIM STUD WELD	1
6	CC-34324	ELEC WARMER CONTROL W/ TIMER	1
7	NU-26526	NUT, #8-32 UNC KEPS ZP	4
8	5012606	1000-S ELEC 230V, ELEC CHASSIS	1
9	TT-33476	THERMOSTAT, 300F HI-LIMIT	1
10	1003936	HI-LIMIT PROTECTION COVER	1
11	SC-22271	SCREW,M4x0.7X6MM PAN	4
12	SW-34769	SWITCH,ROCKER,125-277V,20A	1
13	CV-38297	COVER, IPX RATED, SW-34769	1
14	1010119	HI-LIMIT BULB HOLDER	1
15	BU-3964	BUSHING,STRAIGHT,STRAIN RELIEF	1
16	NU-22770	NUT, THREADED INSERT, M6	1
17	SC-22924	HHCS, M6 X 20, W/NO MARKING	1
18	WS-22302	WASHER, SPLIT LOCK	2
19	WS-22297	WASHER, FLAT	2
20	SN-38110	SENSOR, 100 OHM, 110" WIRE,	1
21	BK-29605	BLOCK, SENSOR, ELEC. CONTROL	1
22	1493	GUARD SENSOR,W/MW	1
23	1006871	NON-PRODUCT PROBE SEAL	1
24	SR-2120	1000-S,UP SIDE RACK	2

## 1000-S Bonnet Package "Q", Electronic Control w/Timer 120V Rev Door

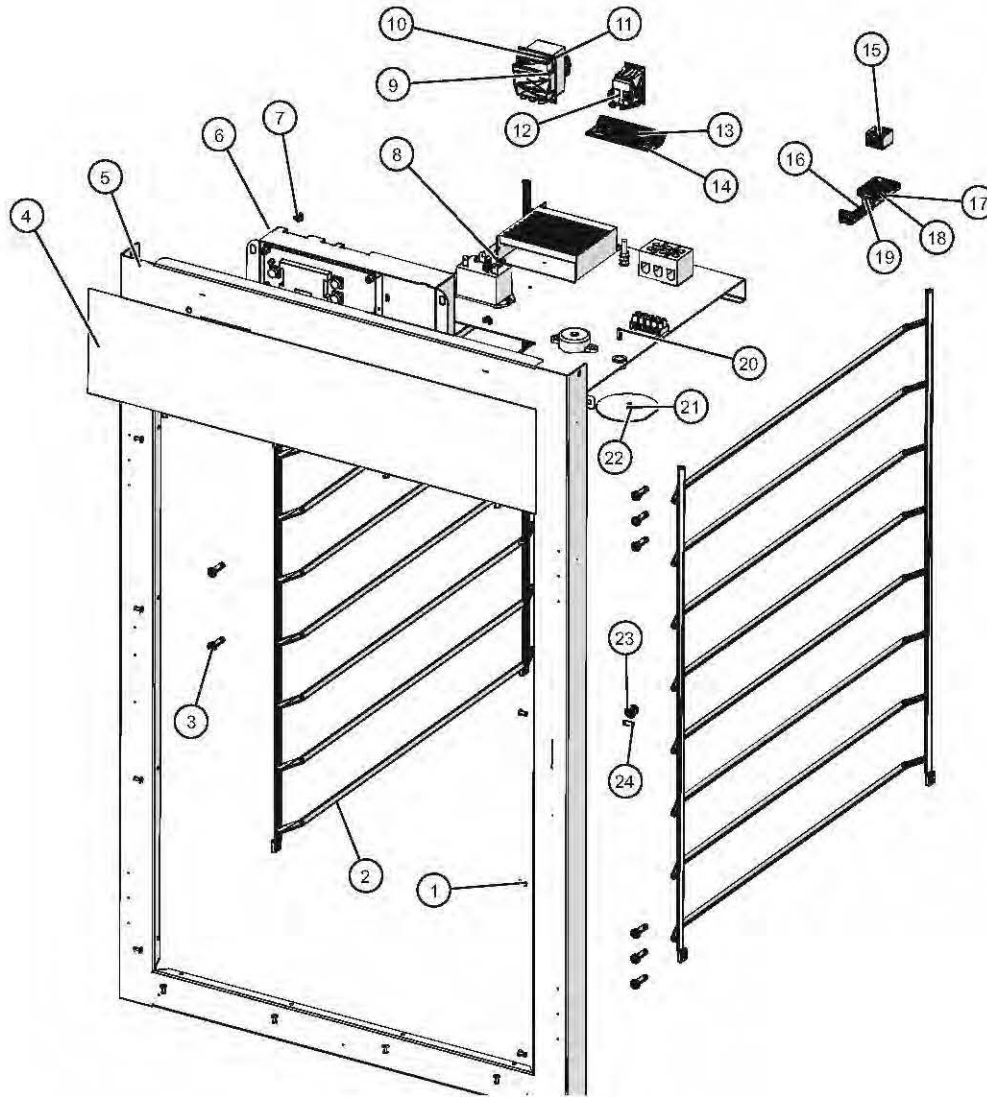

ID	Part No.	Description	Qty
1	RI-2100	RIVET,BLIND,#44,STNLS	16
2	SR-36612	SIDE RACK, 1000-S, CHROME PLATED	2
3	SC-22779	SCREW,M5x0.8X20MM PAN	8
4	PE-27906	1000-S ELECTRONIC OVERLAY	1
5	5012609	1000-UP ELEC FRONT TRIM STUD WELD	1
6	CC-34324	ELEC WARMER CONTROL W/ TIMER	1
7	NU-26526	NUT, #8-32 UNC KEPS ZP	4
8	5012604	WARMER SERIES ELEC 120V,	1
9	TT-33476	THERMOSTAT, 300F HI-LIMIT	1
10	SC-22271	SCREWS,M4-0.7X6MM PHIL	2
11	1003936	HI-LIMIT PROTECTION COVER	1
12	SW-34769	SWITCH,ROCKER,125-277V,20A	1
13	1010119	HI-LIMIT BULB HOLDER	1
14	RI-2100	RIVET,BLIND,#44,STNLS	2
15	BK-33546	BLOCK, 2 TERMINAL, PORCELAIN	1
16	SN-33541	SENSOR,1 3/4" LENGTH	1
17	SC-22271	SCREW,M4x0.7X6MM PAN	2
18	BK-29605	BLOCK, SENSOR, ELEC. CONTROL	1
19	1493	GUARD SENSOR,W/MW	1
20	SW-33559	SWITCH, REED, SPST	1
21	1006871	NON-PRODUCT PROBE SEAL	1
22	SC-22271	SCREWS,M4-0.7X6MM PHIL	1
23	BU-3419	3/8" BLACK HOLE BUSHING	1
24	SW-33559	SWITCH, REED, SPST	1

# 1000-UP Bonnet Package "A", Manual 120V

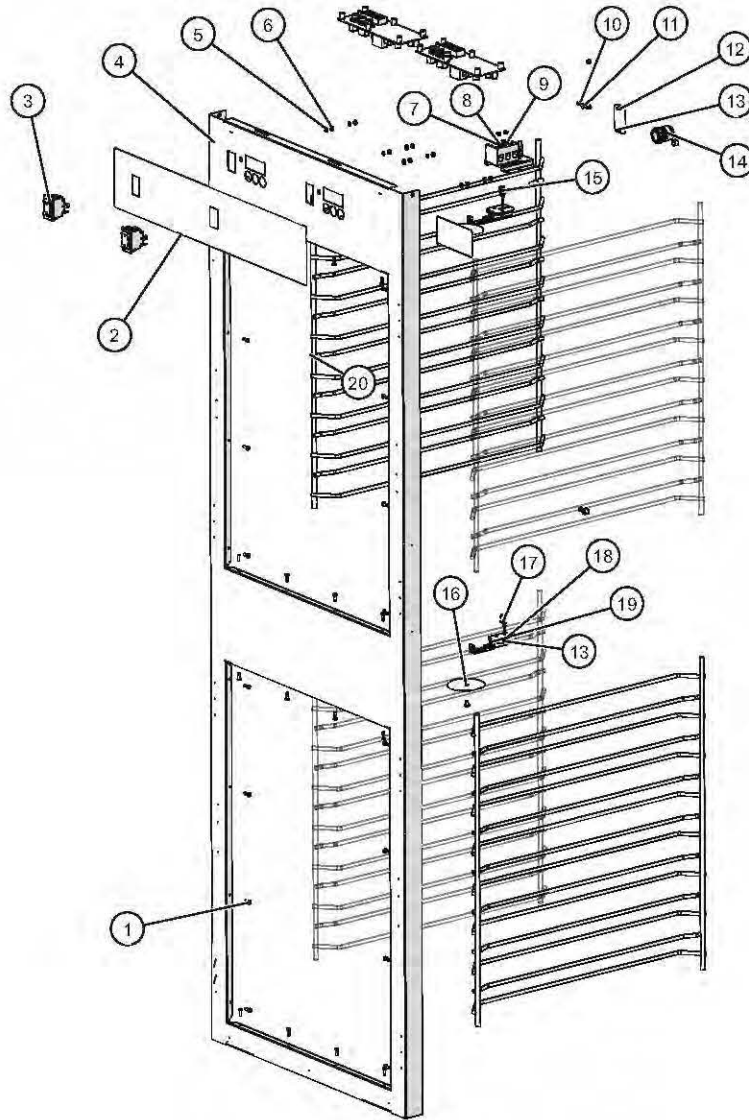

ID	Part No.	Description	Qty
1	RI-27108	RIVET, SEALED	32
2	PE-29394	PANEL, OVERLAY, 1000-UP ELAN 2010	1
3	SW-34769	SWITCH,ROCKER,125-277V,20A	2
4	5012113	1000-UP ELAN CONTROL	1
5	WS-23148	WASHER, 6-32, FLAT, NYL	7
6	NU-2361	NUT, 6-32 HEX, S/S	10
7	WS-23424	WASHER, FLAT, #8, 18-8 SST	2
8	WS-22300	WASHER, SPLIT LOCK	2
9	5012553	CONTROL ASSY,SIMPLE,DOUBLES,	1
10	PG-28439	PLUG, DOME,.187" HOLE	4
11	PG-25574	3/8" HOLE PLUG	3
12	1011697	BREAKER SWITCH CUTOFF COVER	1
13	SC-22271	SCREWS,M4-0.7X6MM PHIL	8
14	BU-3964	BUSHING,STRAIGHT,STRAIN RELIEF	1
15	SN-47162	SENSOR, 1000 OHM, 40" WIRE,	1
16	1006871	NON-PRODUCT PROBE SEAL	2
17	SN-38111	SENSOR, 1000 OHM, 110" WIRE,	1
18	BK-29605	BLOCK, SENSOR, ELEC. CONTROL	2
19	1493	GUARD SENSOR,W/MW	2
20	SR-2120	1000-S,UP SIDE RACK	4

## 1000-UP Bonnet Package "B", Manual 208V-240V

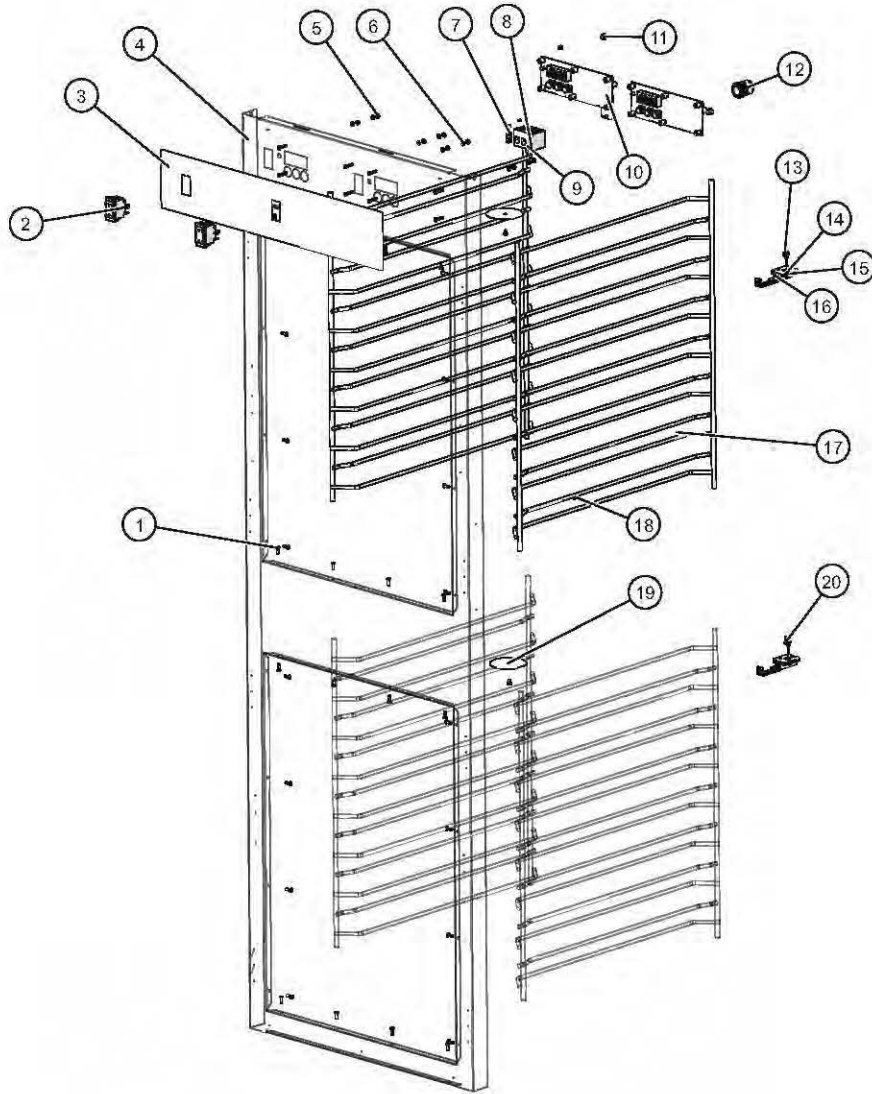

ID	Part No.	Description	Qty
1	RI-27108	RIVET, SEALED	32
2	SW-34769	SWITCH,ROCKER,125-277V,20A	2
3	PE-29394	PANEL, OVERLAY, 1000-UP ELAN 2010	1
4	5012113	1000-UP FRONT TRIM ASSY	1
5	NU-2361	NUT, 6-32 HEX, S/S	10
6	WS-23148	WASHER, 6-32, FLAT, NYL	7
7	5012554	1000/1200-UP ML 208/240V,	1
8	WS-23424	WASHER, FLAT, #8, 18-8 SST	2
9	WS-22300	WASHER, SPLIT LOCK	2
10	1011697	BREAKER SWITCH CUTOFF COVER	1
11	PG-25574	3/8" HOLE PLUG	3
12	BU-3964	BUSHING, STRAIGHT, STRAIN RELIEF	1
13	SN-47162	SENSOR, 1000 OHM, 40" WIRE,	1
14	BK-29605	BLOCK, SENSOR, ELEC. CONTROL	2
15	SC-22271	SCREWS, M4-0.7X6MM PHIL	8
16	1493	GUARD SENSOR, W/MW	2
17	SR-2120	1000-S, UP SIDE RACK	4
18	PG-28439	PLUG, DOME, .187" HOLE	4
19	1006871	NON-PRODUCT PROBE SEAL	2
20	SN-38111	SENSOR, 1000 OHM, 110" WIRE	2

# 1000-UP Bonnet Package "C", Manual 230V

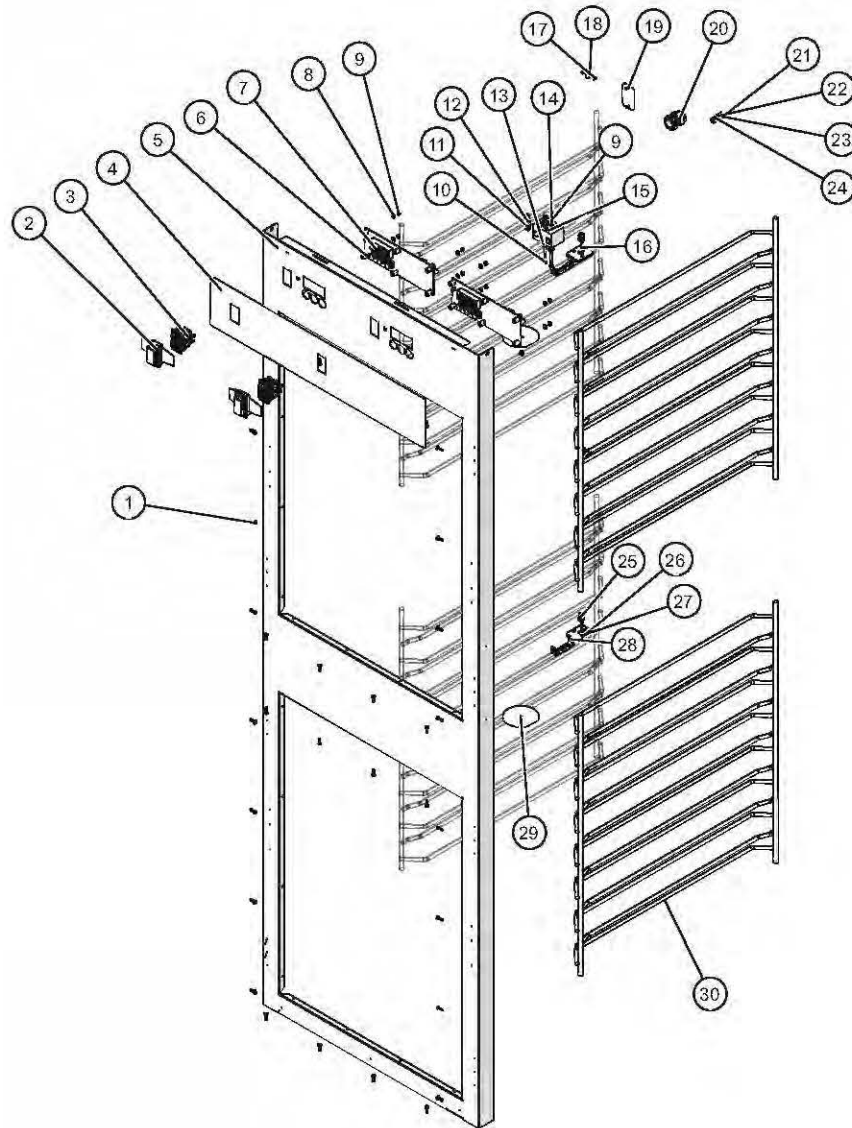

ID	Part No.	Description	Qty
1	RI-27108	RIVET, SEALED, 0125"x0.45"	32
2	CV-38297	COVER, IPX RATED, SW-34769	2
3	SW-34769	SWITCH,ROCKER,125-277V,20A	2
4	PE-29394	PANEL, OVERLAY, 1000-UP ELAN	1
5	5012113	1000-UP ELAN CONTROL	1
6	SP-29392	SPACER, SNAP-IN, 7/16"	12
7	5012555	ELEC. CHASSIS, 1000/1200-UP	1
8	WS-23148	WASHER, 6-32, FLAT, NYL	8
9	NU-2361	NUT, 6-32 HEX, S/S	10
10	SC-47136	SCREW,6-32X1-1/2" PAN	2
11	SC-38128	SCREW,PAN PH, METRIC, M5	1
12	NU-36234	NUT, M5, KEPS	3
13	WS-23424	WASHER, FLAT, #8, 18-8 SST	2
14	WS-22300	WASHER, SPLIT LOCK, M4, 18-8 SST	2
15	BK-3019	T-BLOCK	1
16	SN-47162	SENSOR, 1000 OHM, 40" WIRE,	1
17	PG-28439	PLUG, DOME, .187" HOLE	4
18	PG-25574	3/8" HOLE PLUG	2
19	1011697	BREAKER SWITCH CUTOUT COVER	1
20	BU-3964	BUSHING,STRAIGHT,STRAIN RELIEF	1
21	SC-22924	HHCS, M6 X 20, W/NO MARKING	1
22	WS-22297	WASHER, FLAT,M6, 18-8 SST	2
23	WS-22302	WASHER, SPLIT LOCK, M6, 18-8 SST	2
24	NU-22770	NUT, THREADED INSERT, M6	1
25	SN-38111	SENSOR, 1000 OHM, 110" WIRE,	1
26	SC-22271	SCREWS,M4-0.7X6MM PHIL	4
27	BK-29605	BLOCK, SENSOR, ELEC. CONTROL	2
28	1493	GUARD SENSOR,W/MW	2
29	1006871	NON-PRODUCT PROBE SEAL	2
30	SR-2120	1000-S,UP SIDE RACK	4

# 1000-UP Bonnet Package "D", Electronic 120V

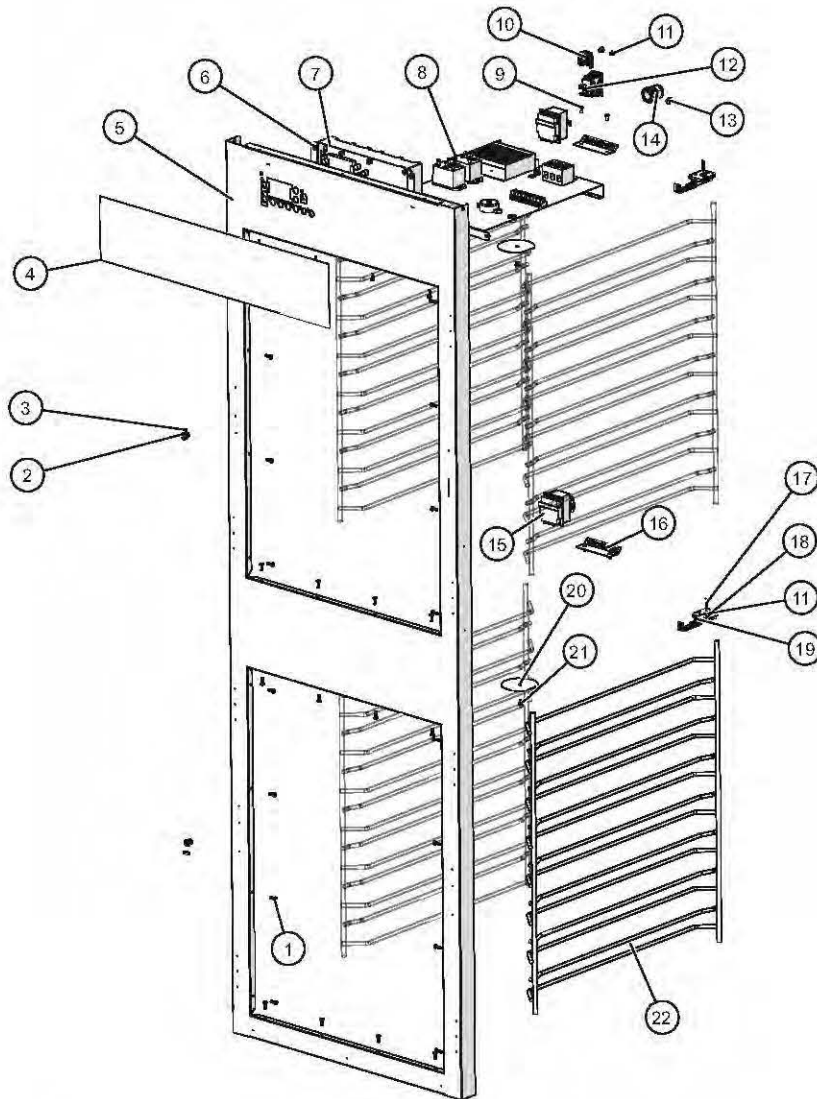

ID	Part No.	Description	Qty
1	RI-27108	RIVET, SEALED, 0.125" x 0.45"	32
2	BU-3419	3/8" BLACK HOLE BUSHING	2
3	SW-33559	SWITCH, REED, SPST	2
4	PE-27938	1000-UP, ELEC, OVERLAY	1
5	5012557	1000-UP ELEC FRONT TRIM STUD WELD	1
6	NU-26526	NUT, #8-32 UNC KEPS ZP	4
7	CC-34326	CONTROL W/O TIMERS	1
8	5012558	1000-UP ELEC 120V, ELEC. CHS	1
9	RI-38125	RIVET,SEALED,.125"	4
10	1003936	HI-LIMIT PROTECTION COVER	2
11	SC-22271	SCREW,M4x0.7X6MM PAN	8
12	SW-34769	SWITCH,ROCKER,125-277V,20A	1
13	PG-25574	3/8" HOLE PLUG	1
14	BU-3964	BUSHING,STRAIGHT,STRAIN RELIEF	1
15	TT-33476	THERMOSTAT, 300F HI-LIMIT	2
16	1010119	HI-LIMIT BULB HOLDER	2
17	SN-38110	SENSOR, 100 OHM, 110" WIRE,	2
18	BK-29605	BLOCK, SENSOR, ELEC. CONTROL	2
19	1493	GUARD SENSOR,W/MW	2
20	1006871	NON-PRODUCT PROBE SEAL	2
21	SC-2459	8-32 x 1/4" PHIL SCREW	2
22	SR-2120	1000-S,UP SIDE RACK	4

# 1000-UP Bonnet Package "E", Electronic 208V-240V

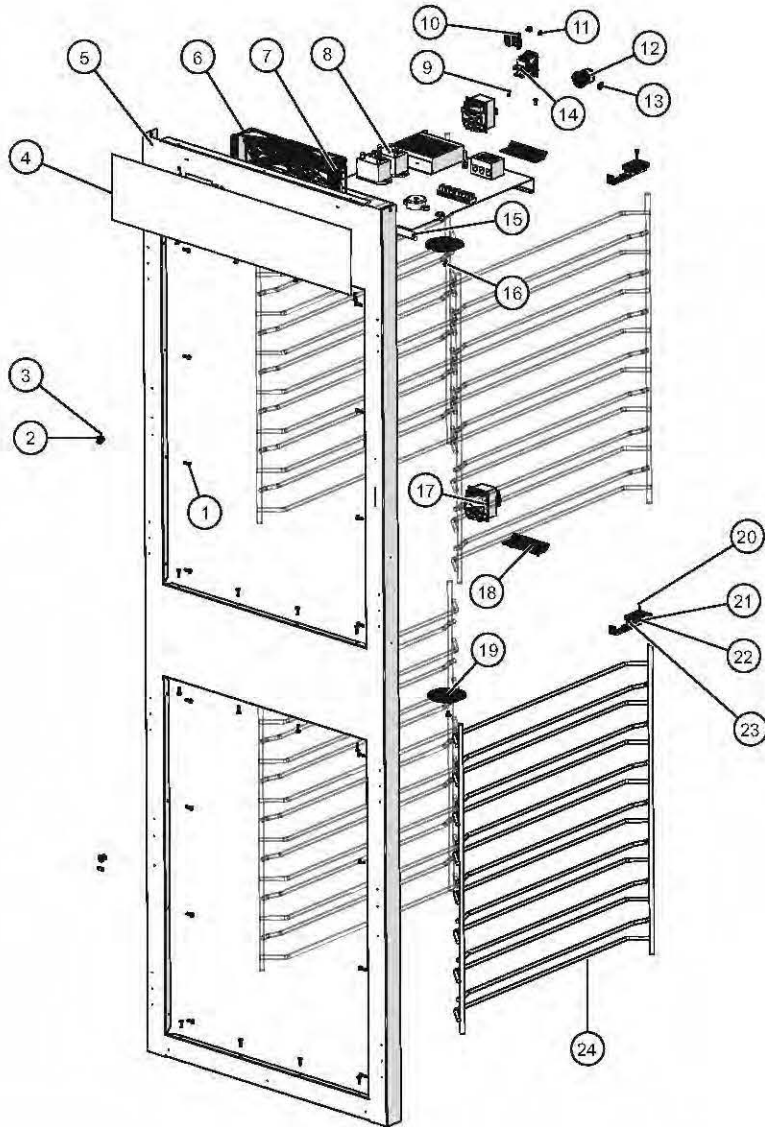

ID	Part No.	Description	Qty
1	RI-27108	RIVET, SEALED	32
2	BU-3419	3/8" BLACK HOLE BUSHING	2
3	SW-33559	SWITCH, REED, SPST	2
4	PE-27938	1000-UP, ELEC, OVERLAY	1
5	5012557	1000-UP ELEC FRONT TRIM STUD WELD	1
6	CC-34326	CONTROL W/O TIMERS	1
7	NU-26526	NUT, #8-32 UNC KEPS ZP	4
8	5012565	1000-UP ELEC 208/240V, ELEC.	1
9	RI-38125	RIVET,SEALED,.125"	4
10	1003936	HI-LIMIT PROTECTION COVER	2
11	SC-22271	SCREW,M4x0.7X6MM PAN	4
12	BU-3964	BUSHING,STRAIGHT,STRAIN RELIEF	1
13	PG-25574	3/8" HOLE PLUG	1
14	SW-34769	SWITCH,ROCKER,125-277V,20A	1
15	NU-2296	NUT, HEX #8-32	2
16	SC-2459	8-32 x 1/4" PHIL SCREW	2
17	TT-33476	THERMOSTAT, 300F HI-LIMIT	2
18	1010119	HI-LIMIT BULB HOLDER	2
19	1006871	NON-PRODUCT PROBE SEAL	2
20	SN-38110	SENSOR, 100 OHM, 110" WIRE,	2
21	SC-22271	SCREW,M4x0.7X6MM PAN	4
22	BK-29605	BLOCK, SENSOR, ELEC. CONTROL	2
23	1493	GUARD SENSOR,W/MW	2
24	SR-2120	1000-S,UP SIDE RACK	4

## 1000-UP Bonnet Package "G", Electronic w/Timer 120V

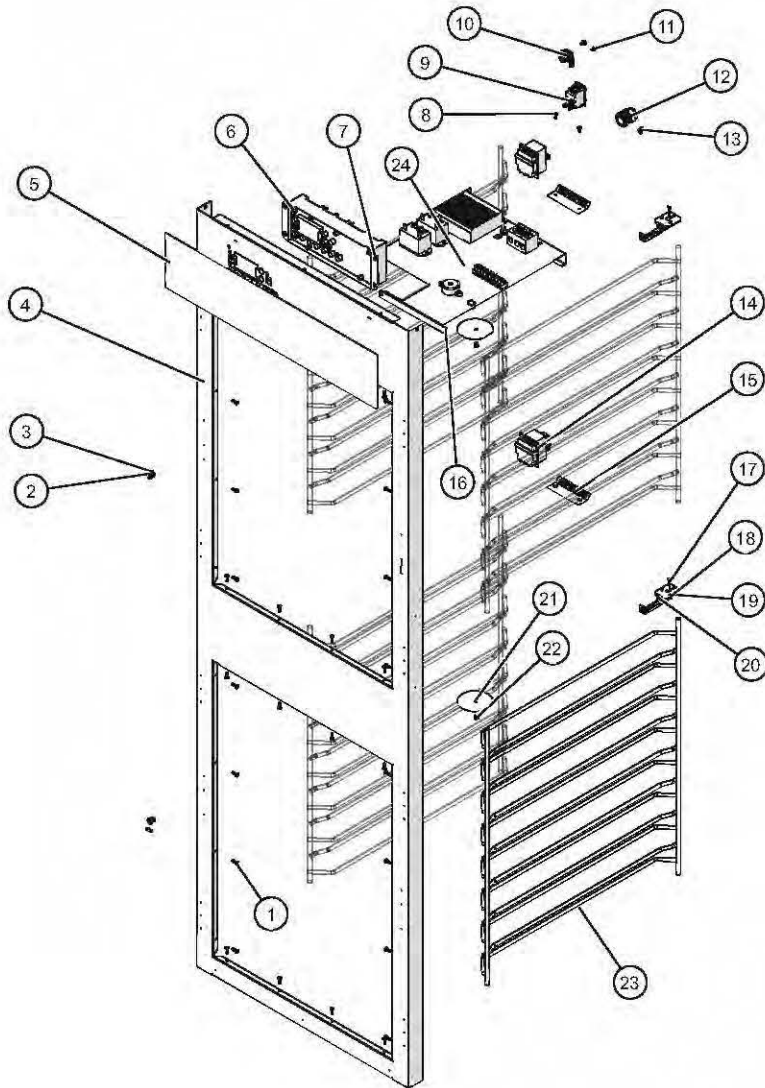

ID	Part No.	Description	Qty
1	RI-27108	RIVET, SEALED, 0.125" X 0.45"	32
2	BU-3419	3/8" BLACK HOLE BUSHING	2
3	SW-33559	SWITCH, REED, SPST	2
4	5012557	1000-UP ELEC FRONT TRIM PANEL	1
5	PE-27937	1000-UP, ELEC, OVERLAY, W/TIMER	1
6	CC-34328	CONTROL W/ TIMERS	1
7	NU-26526	NUT, #8-32 UNC KEPS ZP	4
8	RI-38125	RIVET,SEALED,.125"	4
9	SW-34769	SWITCH,ROCKER,125-277V,20A	1
10	1003936	HI-LIMIT PROTECTION COVER	2
11	SC-22271	SCREW,M4x0.7X6MM PAN	4
12	BU-3964	BUSHING,STRAIGHT,STRAIN RELIEF	1
13	PG-25574	3/8" HOLE PLUG	1
14	TT-33476	THERMOSTAT, 300F HI-LIMIT	2
15	1010119	HI-LIMIT BULB HOLDER	2
16	NU-2296	NUT, HEX #8-32	2
17	SN-38110	SENSOR, 100 OHM, 110" WIRE,	2
18	SC-22271	SCREW,M4x0.7X6MM PAN	4
19	BK-29605	BLOCK, SENSOR, ELEC. CONTROL	2
20	1493	GUARD SENSOR,W/MW	2
21	1006871	NON-PRODUCT PROBE SEAL	2
22	SC-2459	8-32 x 1/4" PHIL SCREW	2
23	SR-2120	1000-S,UP SIDE RACK	4
24	5012558	1000-UP ELEC 120V, ELEC. CHS	1

# 1000-UP Bonnet Package "I", Electronic w/Timer 230V

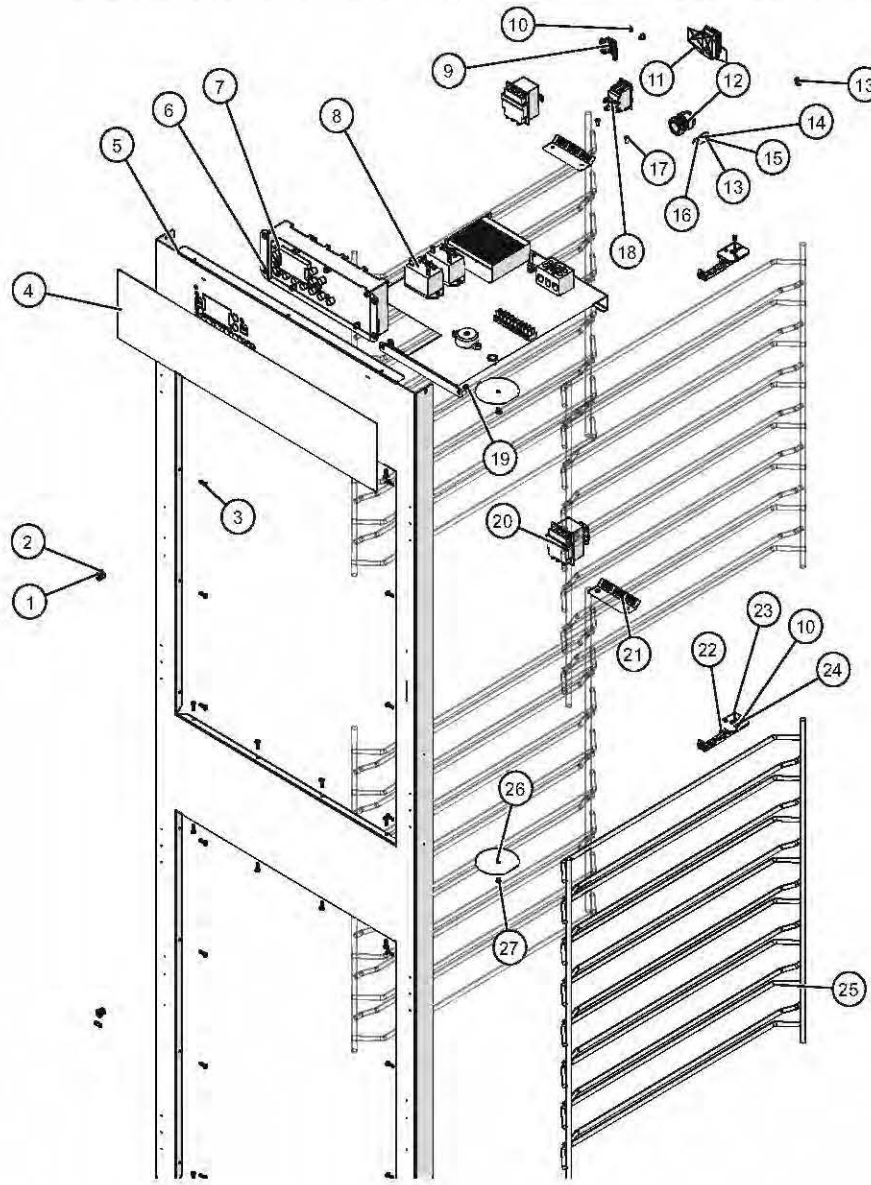

ID	Part No.	Description	Qty
1	BU-3419	3/8" BLACK HOLE BUSHING	2
2	SW-33559	SWITCH, REED, SPST	2
3	RI-27108	RIVET, SEALED, 0.125"X0.45"	32
4	PE-27937	1000-UP, ELEC, OVERLAY, W/TIMER	1
5	5012557	1000-UP ELEC FRONT TRIM ASSY	1
6	NU-26526	NUT, #8-32 UNC KEPS ZP	4
7	CC-34328	CONTROL W/ TIMERS	1
8	5012566	1000-UP ELEC 230V ELEC CHASSIS	1
9	1003936	HI-LIMIT PROTECTION COVER	2
10	SC-22271	SCREW, M4x0.7X6MM PAN	8
11	CV-38297	COVER, IPX RATED, SW-34769	1
12	BU-3964	BUSHING, STRAIGHT, STRAIN RELIEF	1
13	WS-22297	WASHER, FLAT, M6 18-8	2
14	WS-22302	WASHER, SPLIT LOCK, M6 18-8 SST	2
15	SC-22924	HHCS, M6 X 20, W/NO MARKING	1
16	NU-22770	NUT, THREADED INSERT, M6	1
17	RI-38125	RIVET, SEALED, .125", GRIP .039-.118	4
18	SW-34769	SWITCH, ROCKER, 125-277V, 20A	1
19	NU-2296	NUT, HEX #8-32	2
20	TT-33476	THERMOSTAT, 300F HI-LIMIT	2
21	1010119	HI-LIMIT BULB HOLDER	2
22	1493	GUARD SENSOR, W/MW	2
23	SN-38110	SENSOR, 100 OHM, 110" WIRE,	2
24	BK-29605	BLOCK, SENSOR, ELEC. CONTROL	2
25	SR-2120	1000-S, UP SIDE RACK	4
26	1006871	NON-PRODUCT PROBE SEAL	2
27	SC-2459	8-32 x 1/4" PHIL SCREW	2

# 1000-UP Bonnet Package "J", Electronic w/Probe 120V

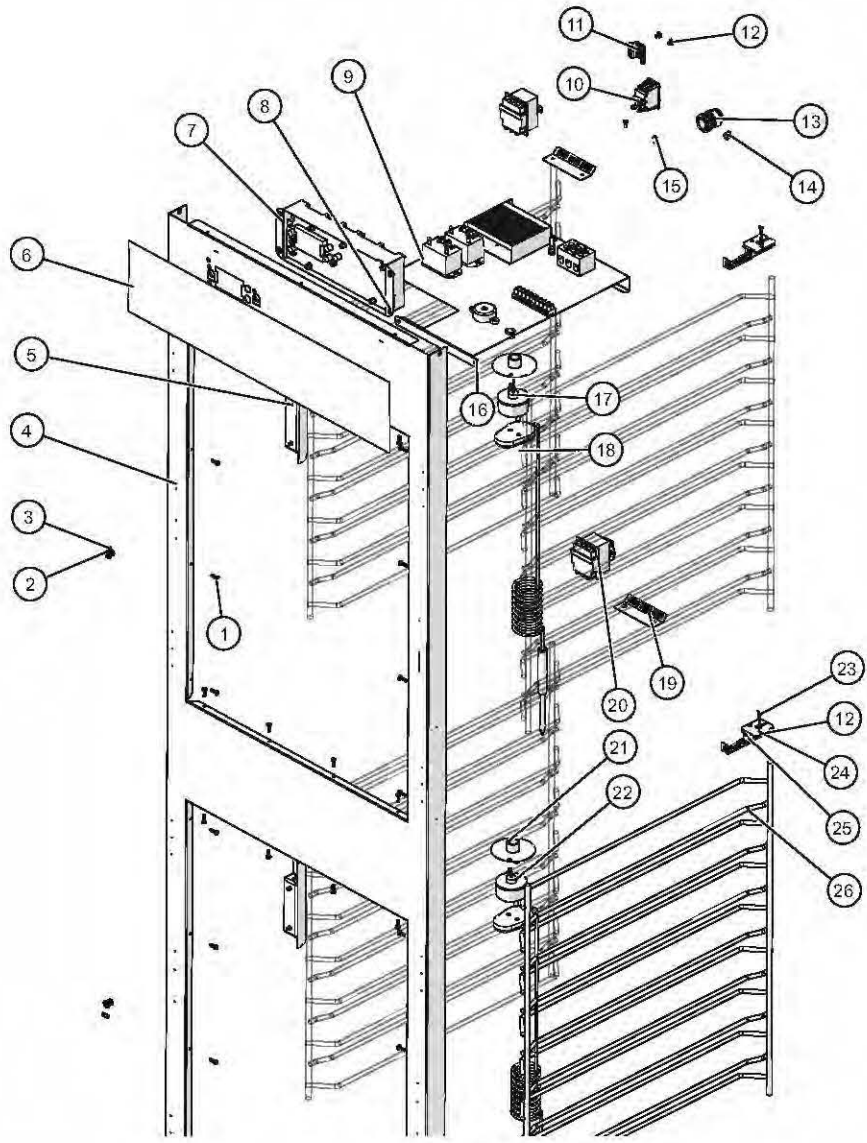

ID	Part No.	Description	Qty
1	RI-27108	RIVET, SEALED, 0.125"x 0.45"	32
2	BU-3419	3/8" BLACK HOLE BUSHING	2
3	SW-33559	SWITCH, REED, SPST	2
4	5012557	1000-UP ELEC FRONT TRIM ASSY	1
5	13239	PROBE HOLDER	2
6	PE-27938	1000-UP, ELEC, OVERLAY	1
7	CC-34326	CONTROL W/O TIMERS	1
8	NU-26526	NUT, #8-32 UNC KEPS ZP	4
9	5012558	1000-UP ELEC 120V, ELEC. CHS	1
10	SW-34769	SWITCH,ROCKER,125-277V,20A	1
11	1003936	HI-LIMIT PROTECTION COVER	2
12	SC-22271	SCREW,M4x0.7X6MM PAN	16
13	BU-3964	BUSHING,STRAIGHT,STRAIN RELIEF	1
14	PG-25574	3/8" HOLE PLUG	1
15	RI-38125	RIVET,SEALED,.125",GRIP .039-.118	4
16	NU-2296	NUT, HEX #8-32	2
17	PR-34705	PROBE,RECEPTACLE,600MM WIRE	1
18	PR-36065	PROBE,QUICK CONNECT,PT100	2
19	1010119	HI-LIMIT BULB HOLDER	2
20	TT-33476	THERMOSTAT, 300F HI-LIMIT	2
21	5009712	PROBE COVER WELDMENT	2
22	PR-34704	PROBE, RECEPTACLE, 2200MM WIRE	1
23	SN-38110	SENSOR, 100 OHM, 110" WIRE,	2
24	BK-29605	BLOCK, SENSOR, ELEC. CONTROL	2
25	1493	GUARD SENSOR,W/MW	2
26	SR-2120	1000-S,UP SIDE RACK	4

# 1000-UP Bonnet Package "L", Electronic w/Probe 230V

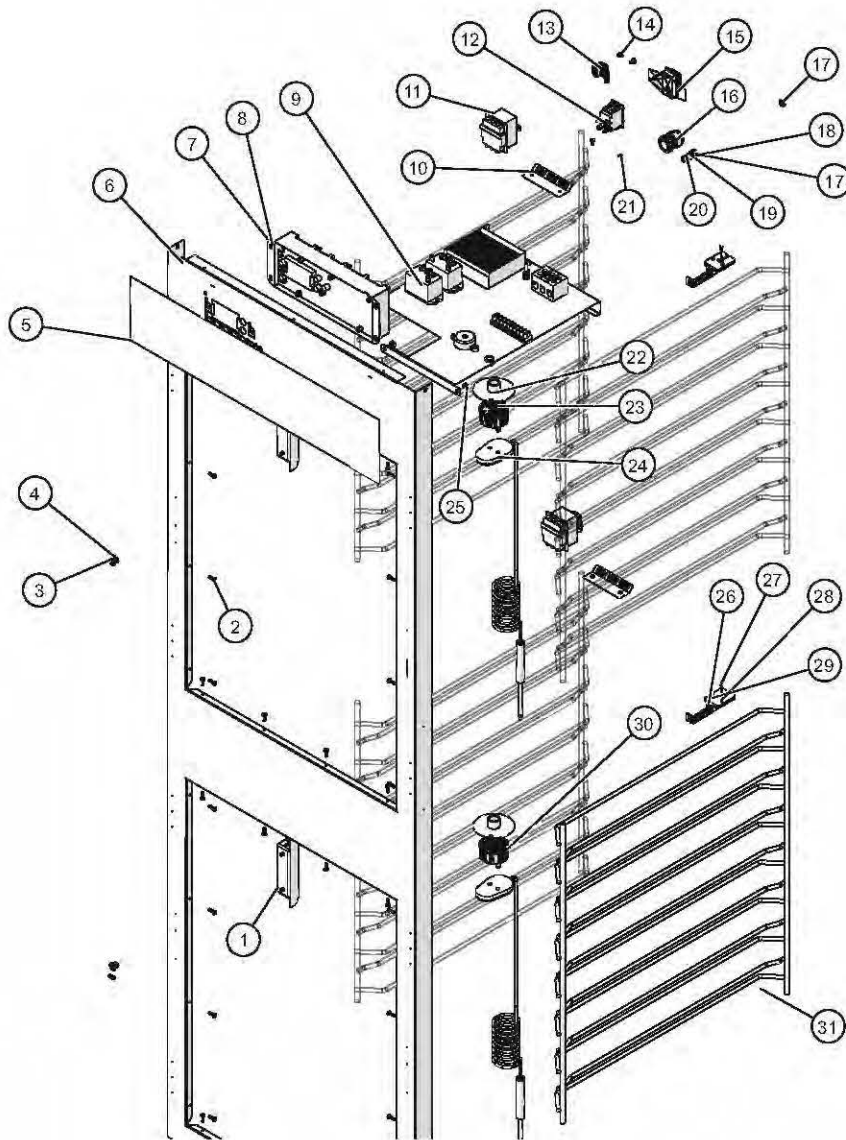

ID	Part No.	Description	Qty
1	13239	PROBE HOLDER	2
2	RI-27108	RIVET, SEALED, 0.125" x 0.45"	32
3	BU-3419	3/8" BLACK HOLE BUSHING	2
4	SW-33559	SWITCH, REED, SPST	2
5	PE-27938	1000-UP, ELEC, OVERLAY	1
6	5012557	1000-UP ELEC FRONT TRIM STUD WELD	1
7	CC-34326	CONTROL W/O TIMERS	1
8	NU-26526	NUT, #8-32 UNC KEPS ZP	4
9	5012566	1000-UP ELEC 230V, ELEC. CHS	1
10	1010119	HI-LIMIT BULB HOLDER	2
11	TT-33476	THERMOSTAT, 300F HI-LIMIT	2
12	SW-34769	SWITCH,ROCKER,125-277V,20A	1
13	1003936	HI-LIMIT PROTECTION COVER	2
14	SC-22271	SCREW,M4x0.7X6MM PAN	12
15	CV-38297	COVER, IPX RATED, SW-34769	1
16	BU-3964	BUSHING,STRAIGHT,STRAIN RELIEF	1
17	WS-22297	WASHER, FLAT, M6, 18-8 SST	2
18	SC-22924	HHCS, M6 X 20, W/NO MARKING	1
19	WS-22302	WASHER, SPLIT LOCK M6, 18-8 SST	2
20	NU-22770	NUT, THREADED INSERT, M6	1
21	RI-38125	RIVET,SEALED,.125",GRIP .039-.118	4
22	5009712	PROBE COVER WELDMENT	2
23	PR-34705	PROBE,RECEPTACLE,600MM WIRE	1
24	PR-36065	PROBE,QUICK CONNECT,PT100	2
25	NU-2296	NUT, HEX #8-32	2
26	1493	GUARD SENSOR,W/MW	2
27	SN-38110	SENSOR, 100 OHM, 110" WIRE,	2
28	BK-29605	BLOCK, SENSOR, ELEC. CONTROL	2
29	SC-22271	SCREW,M4x0.7X6MM PAN	4
30	PR-34704	PROBE, RECEPTACLE, 2200MM WIRE	1
31	SR-2120	1000-S,UP SIDE RACK	4

## Chassis Assembly, S-Series, Manual 120V

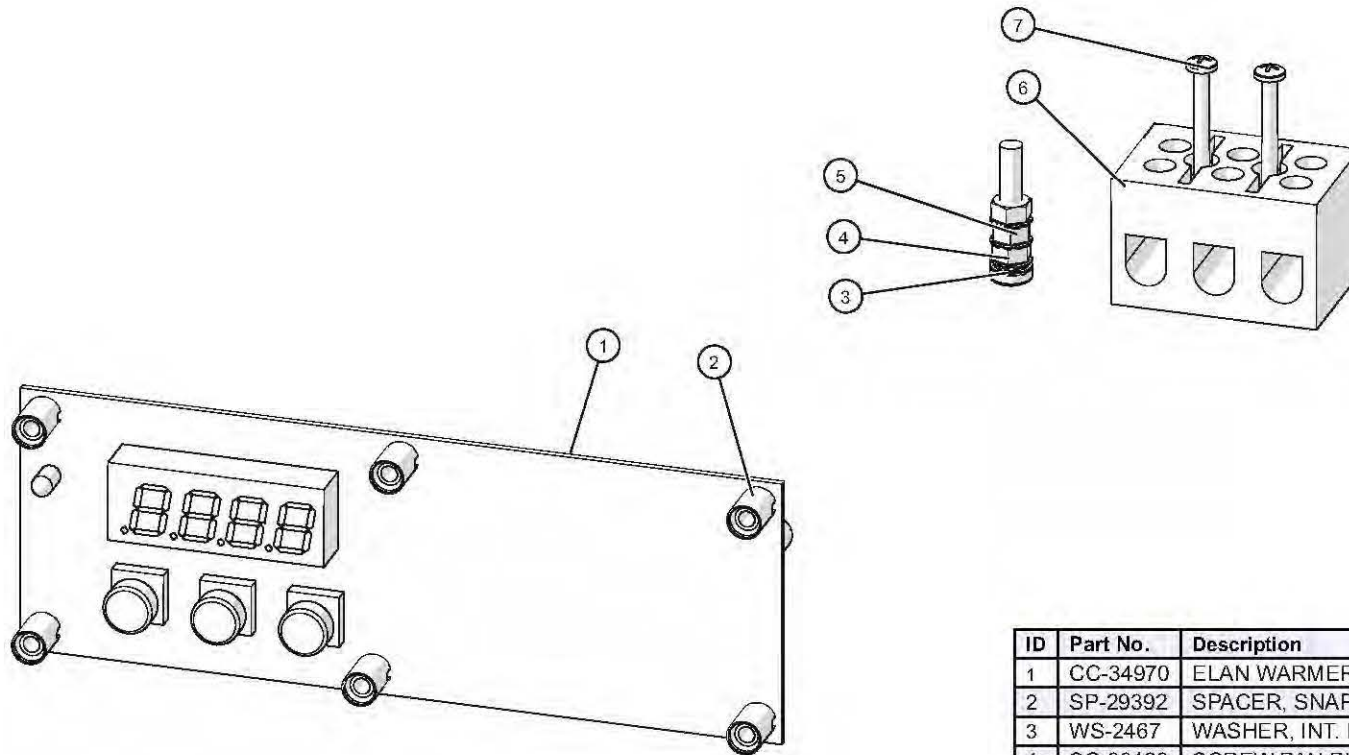

ID	Part No.	Description	Qty
1	CC-34970	ELAN WARMER CONTROL	1
2	SP-29392	SPACER, SNAP-IN, 7/16"	6
3	WS-2467	WASHER, INT. LOCK	1
4	SC-38128	SCREW,PAN PH, METRIC, M5	1
5	NU-36234	NUT, M5, KEPS	3
6	BK-3019	T-BLOCK	1
7	SC-47136	SCREW,6-32X1-1/2" PAN	2

# Chassis Assembly, S-Series, Manual 208-240V

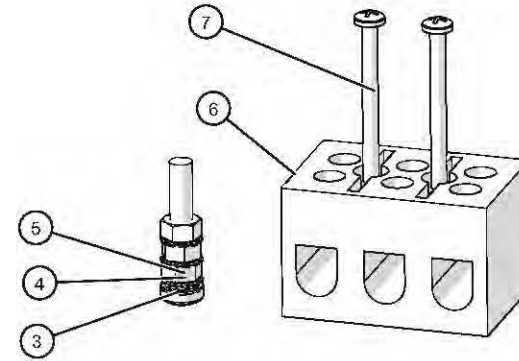
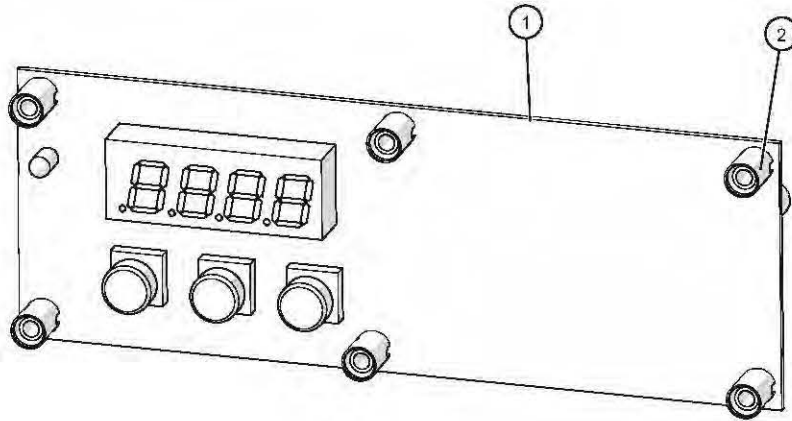

ID	Part No.	Description	Qty
1	CC-34970	ELAN WARMER CONTROL	1
2	SP-29392	SPACER, SNAP-IN, 7/16"	6
3	WS-2467	WASHER, INT. LOCK	1
4	SC-38128	SCREW,PAN PH, METRIC, M5	1
5	NU-36234	NUT, M5, KEPS	3
6	BK-3019	T-BLOCK	1
7	SC-47136	SCREW,6-32X1-1/2" PAN	2

## Chassis Assembly, S-Series, Manual 230V

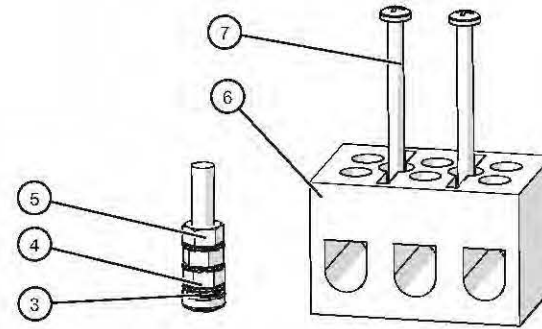
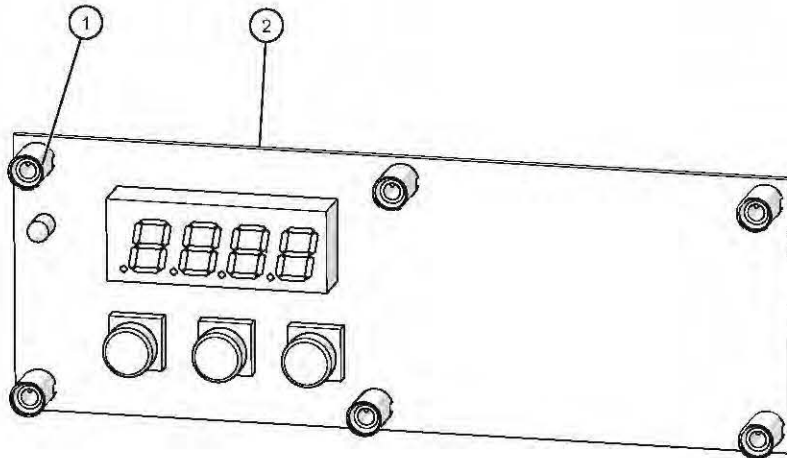

ID	Part No.	Description	Qty
1	SP-29392	SPACER, SNAP-IN, 7/16"	6
2	CC-34970	ELAN WARMER CONTROL	1
3	WS-2467	WASHER, INT. LOCK	1
4	SC-38128	SCREW,PAN PH, METRIC, M5	1
5	NU-36234	NUT, M5, KEPS	3
6	BK-3019	T-BLOCK	1
7	SC-47136	SCREW,6-32X1-1/2" PAN	2

## Chassis Assembly, 1000-S, Electronic 208V-240V

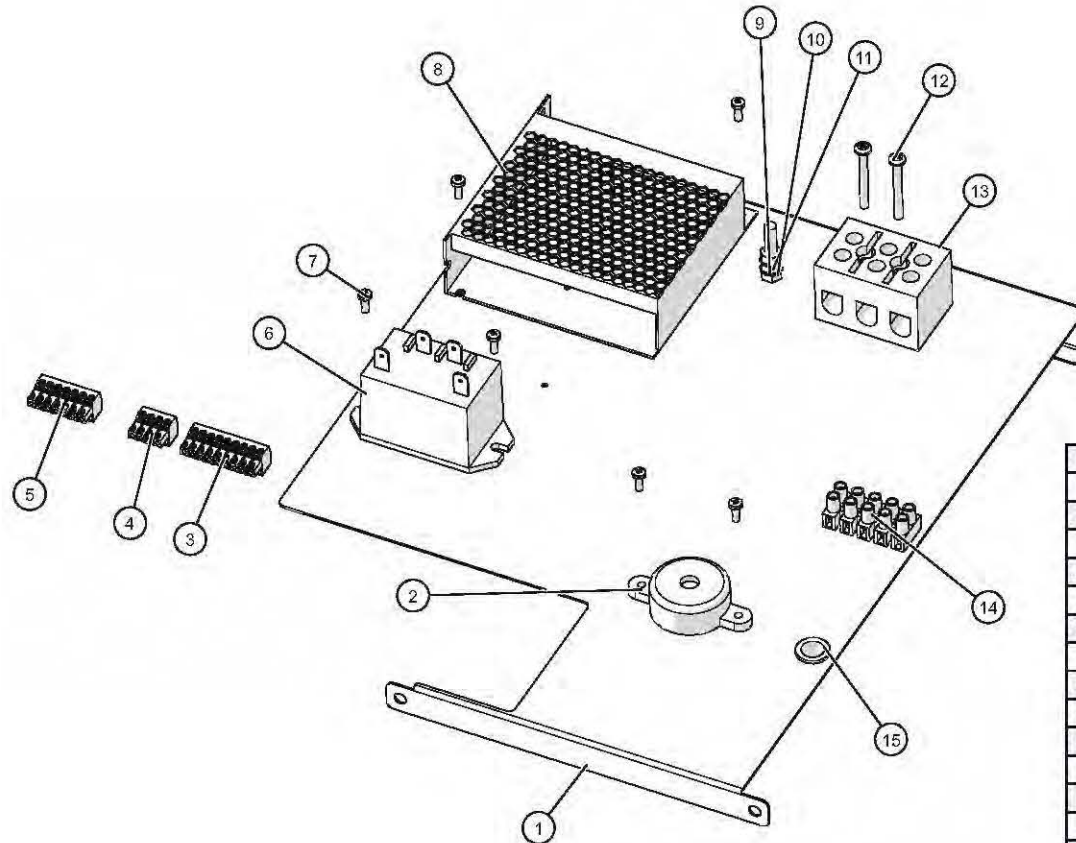

ID	Part No.	Description	Qty
1	1011531	WARMER SERIES ELEC CHASSIS	1
2	BP-3567	BEEPER, SOLID STATE, 1.5-20V	1
3	CR-33718	CONNECTOR 9 PIN	1
4	CR-33763	CONNECTOR 4 PIN	1
5	CR-33761	CONNECTOR, 7 PIN	1
6	RL-33558	RELAY, SPST 30A @ 277 VAC 12VDC	1
7	SC-22268	SCREW, M3x0.5X8MM PAN	6
8	BA-38586	BOARD, POWER SUPPLY, 12V	1
9	SC-38128	SCREW, PAN PH, METRIC, M5	1
10	WS-2467	WASHER, INT. LOCK	1
11	NU-36234	NUT, M5, KEPS	3
12	SC-2365	SCREW, 6-32X1-1/4, NC PHILLIPS	2
13	BK-3019	T-BLOCK	1
14	TM-33560	TERMINAL, STRIP, 5 CIRCUIT, UL, VDE	1
15	BU-3006	1/2" HOLE BUSHING	1

## Chassis Assembly, 1000-S, Electronic 230V

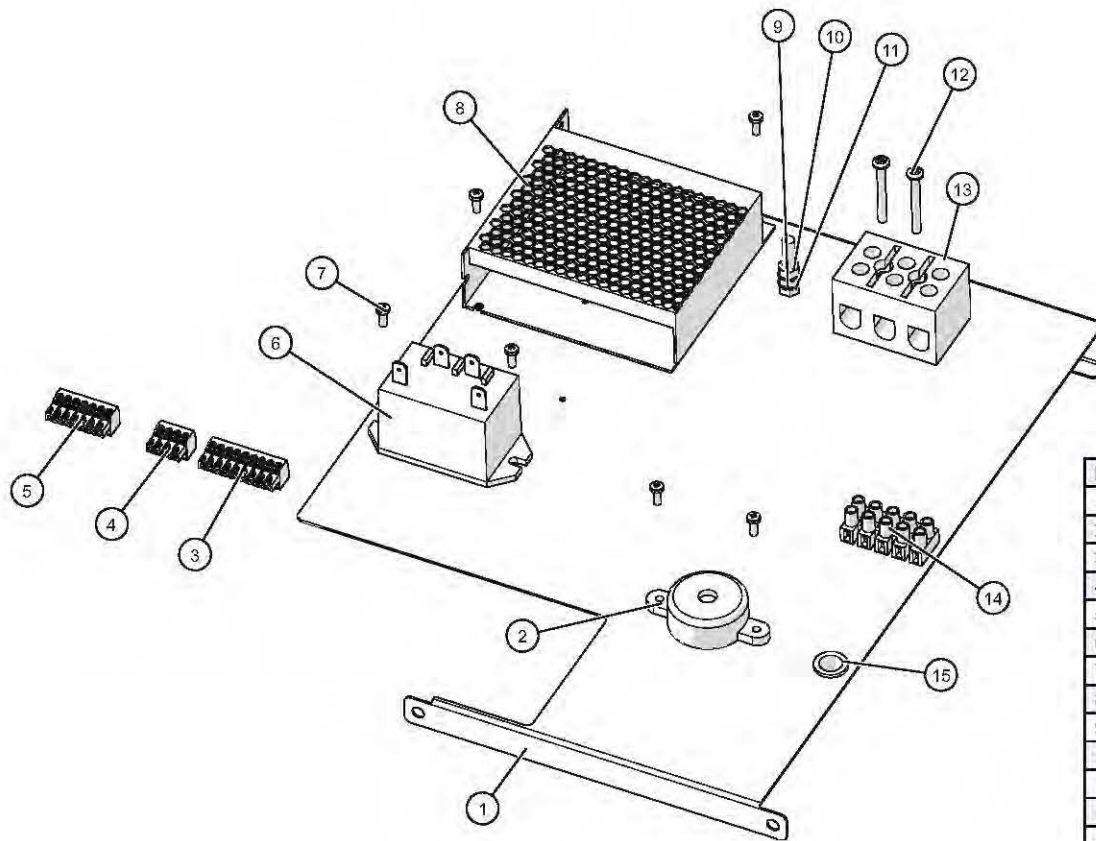

ID	Part No.	Description	Qty
1	1011531	WARMER SERIES ELEC CHASSIS	1
2	BP-3567	BEEPER, SOLID STATE, 1.5-20V	1
3	CR-33718	CONNECTOR 9 PIN	1
4	CR-33763	CONNECTOR 4 PIN	1
5	CR-33761	CONNECTOR, 7 PIN	1
6	RL-33558	RELAY, SPST 30A @ 277 VAC 12VDC	1
7	SC-22268	SCREW,M3x0.5X8MM PAN	6
8	BA-38586	BOARD, POWER SUPPLY, 12V	1
9	SC-38128	SCREW,PAN PH, METRIC, M5	1
10	NU-36234	NUT, M5, KEPS	3
11	WS-2467	WASHER, INT. LOCK	1
12	SC-2365	SCREW,6-32X1-1/4,NC PHILLIPS	2
13	BK-3019	T-BLOCK	1
14	TM-33560	TERMINAL,STRIP,5CIRCUIT,UL,VDE	1
15	BU-3006	1/2" HOLE BUSHING	1

# Chassis Assembly, 1000-UP, Electronic 120V

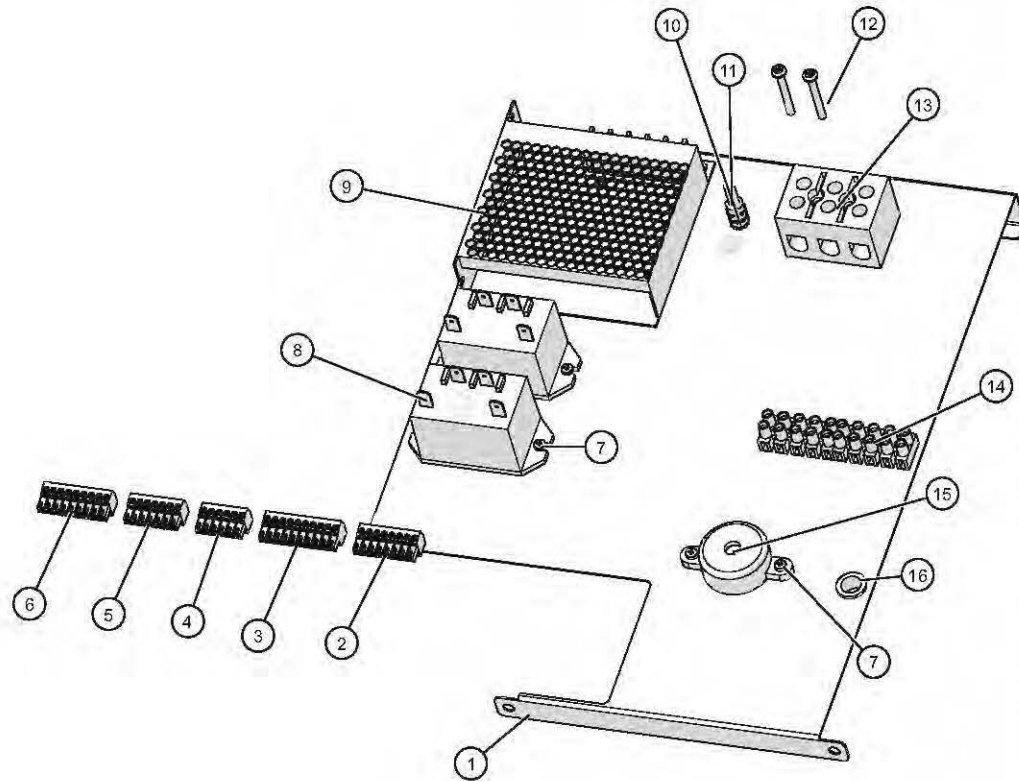

ID	Part No.	Description	Qty
1	1011531	WARMER SERIES ELEC CHASSIS	1
2	CR-33719	CONNECTOR 8 PIN	1
3	CR-33717	CONNECTOR, 10 PIN, PLUGGABLE TERMINAL	1
4	CR-33762	CONNECTOR 6 PIN	1
5	CR-33761	CONNECTOR, 7 PIN	1
6	CR-33718	CONNECTOR 9 PIN	1
7	SC-22268	SCREW,M3x0.5X8MM PAN	8
8	RL-33558	RELAY, SPST 30A @ 277 VAC 12VDC	2
9	BA-38586	BOARD, POWER SUPPLY, 12V	1
10	SC-38128	SCREW,PAN PH, METRIC, M5 x 30MM, GRN	1
11	NU-36234	NUT, M5, KEPS	3
12	SC-2365	SCREW,6-32X1-1/4,NC PHILLIPS	2
13	BK-3019	T-BLOCK	1
14	TM-33560	TERMINAL,STRIP,5 CIRCUIT,UL,VDE	2
15	BP-3567R	BEEPER, SOLID STATE, 1.5-20V	1
16	BU-3006	1/2" HOLE BUSHING	1
17	5007874	WIRE ASSY, 1000-UP 120V (not shown)	1

## Chassis Assembly, 1000-UP, Electronic 208V-240V

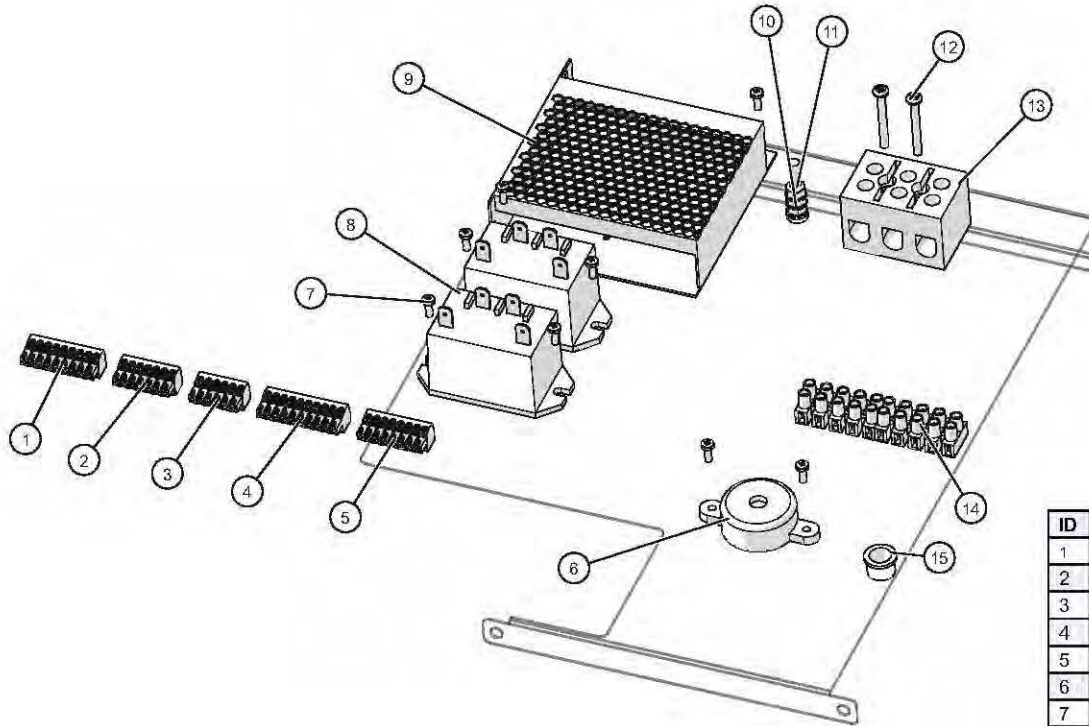

ID	Part No.	Description	Qty
1	CR-33718	CONNECTOR 9 PIN	1
2	CR-33761	CONNECTOR, 7 PIN	1
3	CR-33762	CONNECTOR 6 PIN	1
4	CR-33717	CONNECTOR, 10 PIN	1
5	CR-33719	CONNECTOR 8 PIN	1
6	BP-3567	BEEPER, SOLID STATE, 1.5-20V	1
7	SC-22268	SCREW, M3x0.5X8MM PAN	8
8	RL-33558	RELAY, SPST 30A @ 277 VAC 12VDC	2
9	BA-38586	BOARD, POWER SUPPLY, 12V	1
10	SC-38128	SCREW, PAN PH, METRIC, M5	1
11	NU-36234	NUT, M5, KEPS	3
12	SC-2365	SCREW, 6-32X1-1/4, NC PHILLIPS	2
13	BK-3019	T-BLOCK	1
14	TM-33560	TERMINAL, STRIP, 5 CIRCUIT, UL, VDE	2
15	BU-3006	1/2" HOLE BUSHING	1

# Chassis Assembly, 1000-UP, Electronic 230V

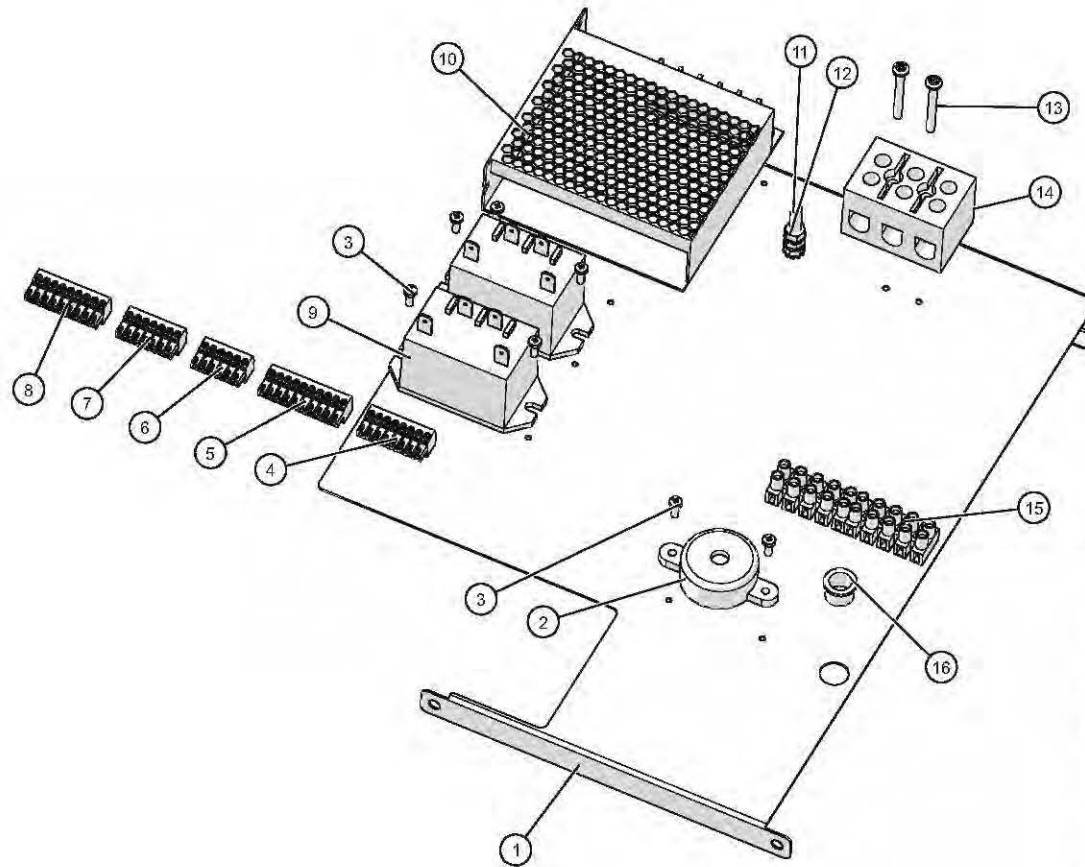

ID	Part No.	Description	Qty
1	1011531	WARMER SERIES ELEC CHASSIS	1
2	BP-3567	BEEPER, SOLID STATE, 1.5-20V	1
3	SC-22268	SCREW, M3x0.5X8MM PAN	8
4	CR-33719	CONNECTOR 8 PIN	1
5	CR-33717	CONNECTOR, 10 PIN, PLUGGABLE TERMINAL	1
6	CR-33762	CONNECTOR 6 PIN	1
7	CR-33761	CONNECTOR, 7 PIN	1
8	CR-33718	CONNECTOR 9 PIN	1
9	RL-33558	RELAY, SPST 30A @ 277 VAC 12VDC	2
10	BA-38586	BOARD, POWER SUPPLY, 12V	1
11	SC-38128	SCREW, PAN PH, METRIC, M5	1
12	NU-36234	NUT, M5, KEPS	3
13	SC-2365	SCREW, 6-32X1-1/4, NC PHILLIPS	2
14	BK-3019	T-BLOCK	1
15	TM-33560	TERMINAL, STRIP, 5 CIRCUIT, UL VDE	2
16	BU-3006	1/2" HOLE BUSHING	1
17	5007815	1000-UP WIRE ASSY, 230V (not shown)	1

## Chassis Assembly, 1000-UP, Electronic Deluxe 2000W

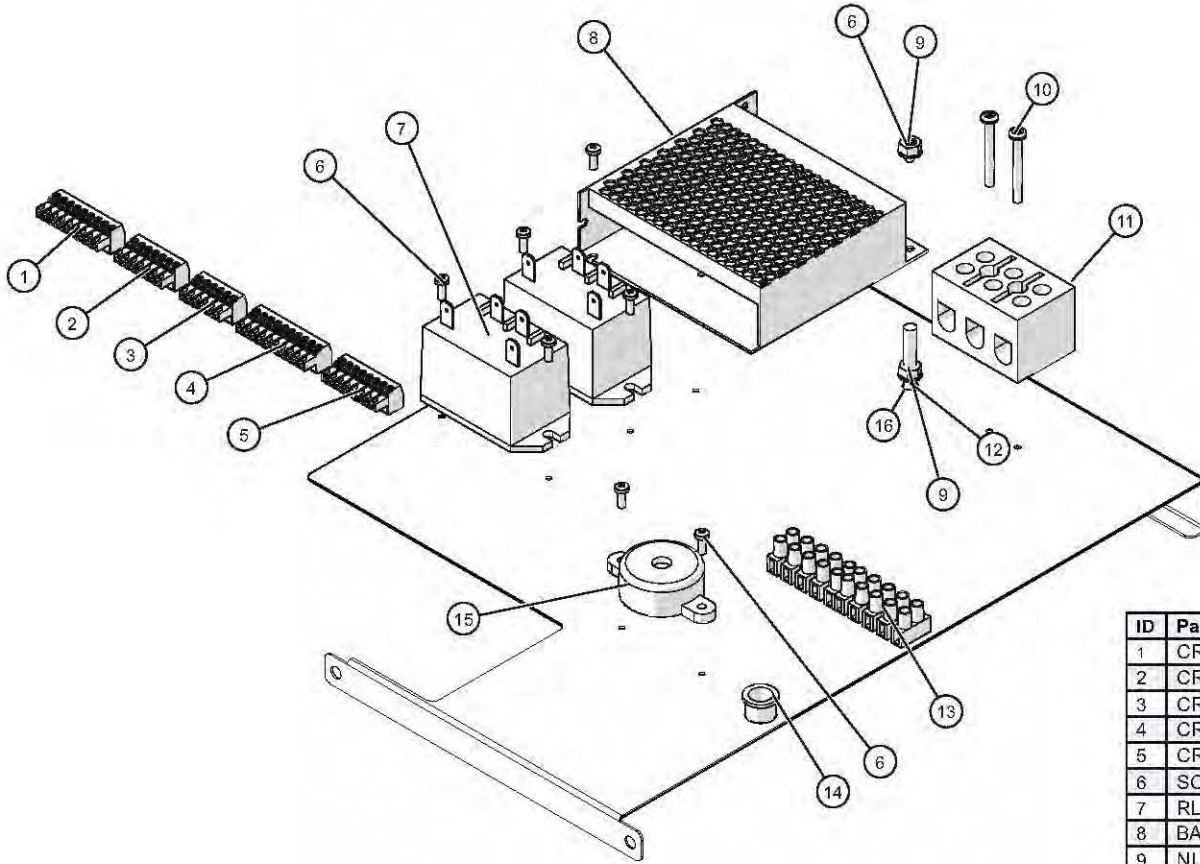

ID	Part No.	Description	Qty
1	CR-33718	CONNECTOR 9 PIN	1
2	CR-33761	CONNECTOR, 7 PIN	1
3	CR-33762	CONNECTOR 6 PIN	1
4	CR-33717	CONNECTOR, 10 PIN	1
5	CR-33719	CONNECTOR 8 PIN	1
6	SC-22268	SCREW,M3x0.5X8MM PAN	8
7	RL-33558	RELAY, SPST 30A @ 277 VAC 12VDC	2
8	BA-38586	BOARD, POWER SUPPLY, 12V	1
9	NU-36234	NUT, M5, KEPS	3
10	SC-2365	SCREW,6-32X1-1/4,NC PHILLIPS	2
11	BK-3019	T-BLOCK	1
12	SC-38128	SCREW,PAN PH, METRIC, M5	1
13	TM-33560	TERMINAL,STRIP,5 CIRCUIT,UL,VDE	2
14	BU-3006	1/2" HOLE BUSHING	1
15	BP-3567	BEEPER, SOLID STATE, 1.5-20V	1
16	WS-2467	WASHER, INT. LOCK, #10, 410 SST	1

## 1000-S Slab Door Package "A", Reach-In

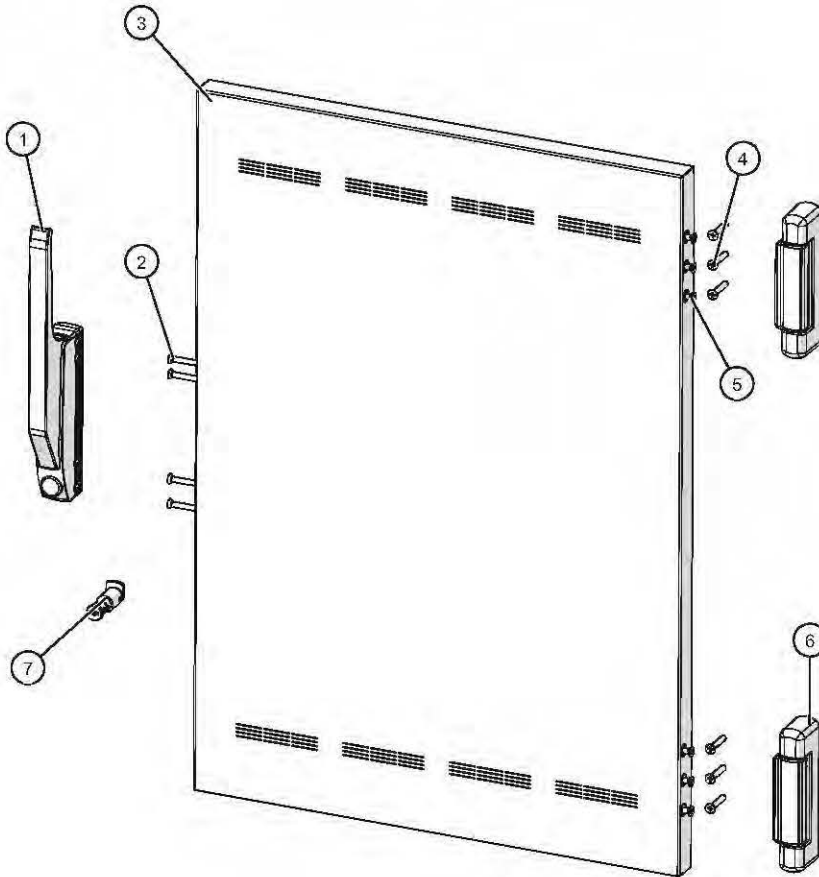

ID	Part No.	Description	Qty
1	HD-27080 (RH)	HANDLE, OFFSET MAG LATCH	1
2	SC-35259	SCREW, M5x0.8X50MM FLAT	4
3	5012801	DOOR, ASSY, 2010	1
4	SC-22853	SCREW, M5x0.8X30MM FLAT	6
5	SC-23868	SCREW, M5x0.8X20MM FLAT	6
6	HG-22338	HINGE, 1-3/8 OFFSET, PAIR, CHROME	1
7	LK-22567	LOCK, CYLINDER (optional)	1

## 1000-S Window Door Package "B", Reach-In

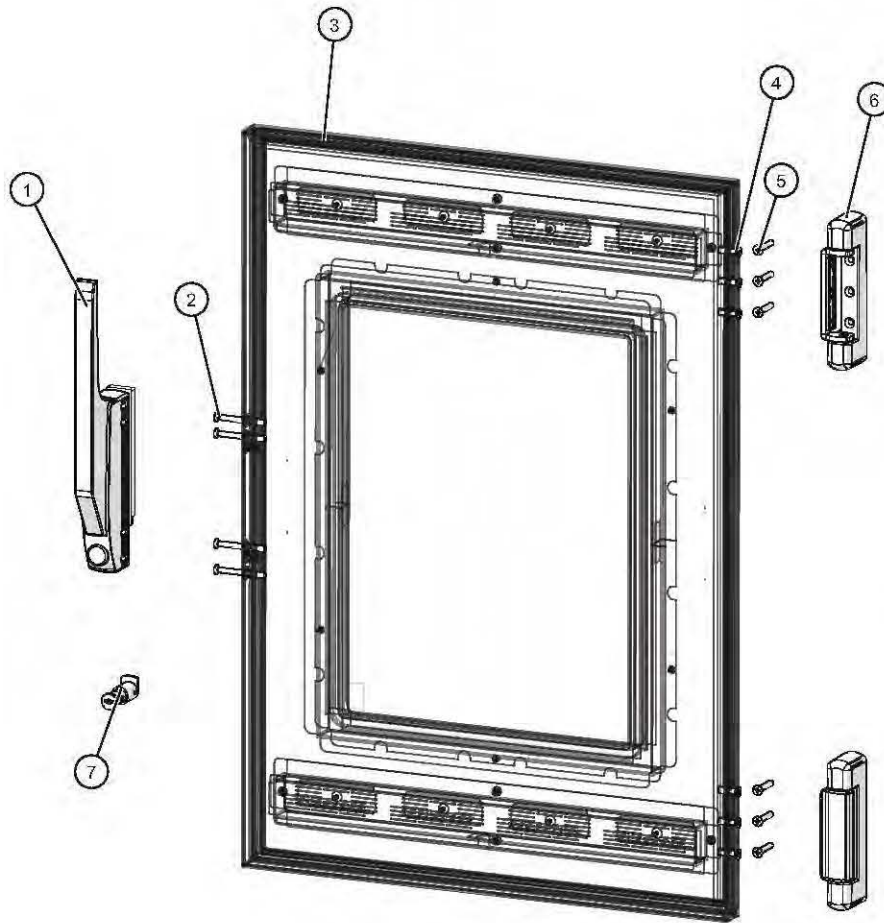

ID	Part No.	Description	Qty
1	HD-27080 (RH)	HANDLE, OFFSET MAG LATCH	1
2	SC-35259	SCREW, M5x0.8X50MM FLAT	4
3	5012806	DOOR, ASSY, WINDOW	1
4	SC-23868	SCREW, M5x0.8X20MM FLAT	6
5	SC-22853	SCREW, M5x0.8X30MM FLAT	6
6	HG-22338	HINGE, 1-3/8 OFFSET, PAIR, CHROME	1
7	LK-22567	LOCK, CYLINDER (optional)	1

## 1000-S Slab Door Package "C", Pass-Thru

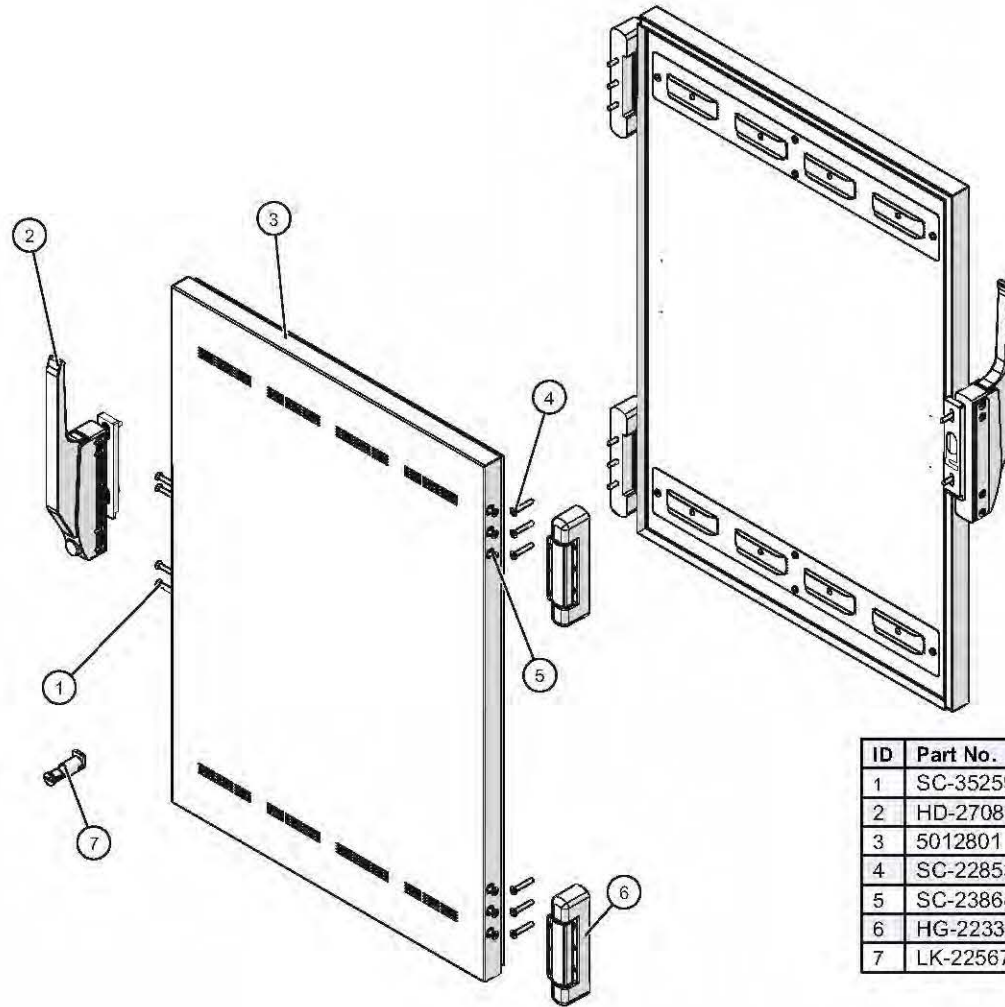

ID	Part No.	Description	Qty
1	SC-35259	SCREW, M5x0.8X50MM FLAT	8
2	HD-27080 (RH)	HANDLE, OFFSET MAG LATCH	2
3	5012801	DOOR, ASSY, 2010	2
4	SC-22853	SCREW, M5x0.8X30MM FLAT	12
5	SC-23868	SCREW, M5x0.8X20MM FLAT	12
6	HG-22338	HINGE, 1-3/8 OFFSET, PAIR, CHROME	2
7	LK-22567	LOCK, CYLINDER (optional)	1

## 1000-S Slab Door Package "E", Reach-In (no vent covers)

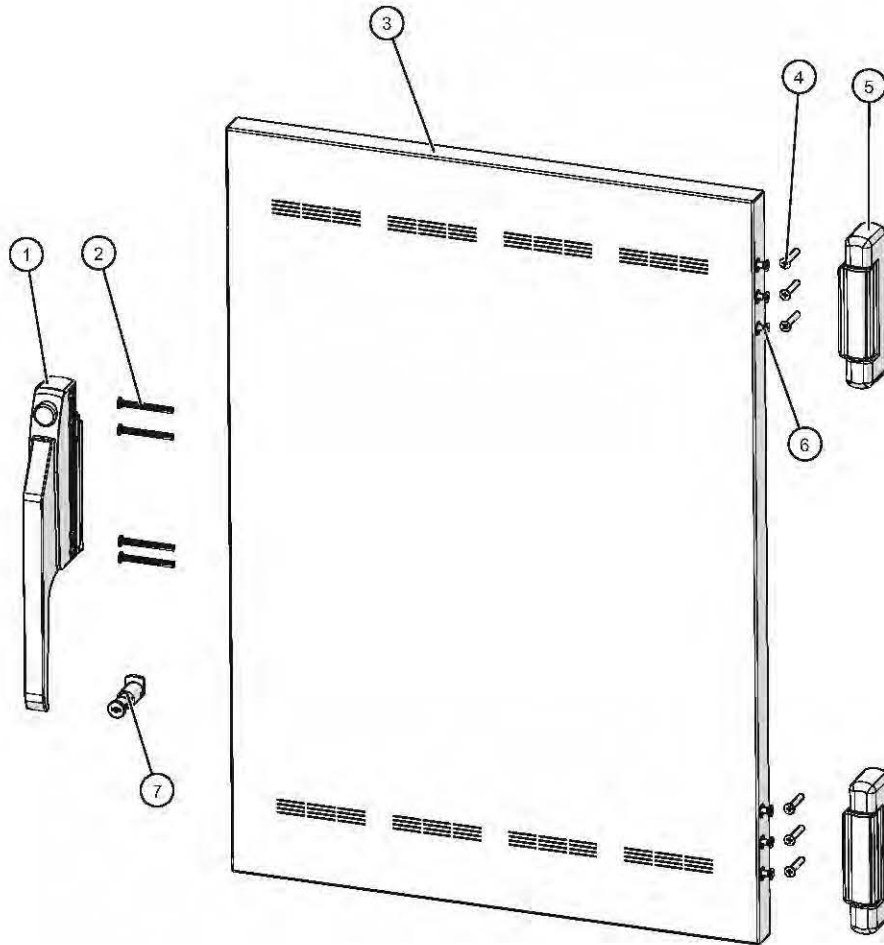

ID	Part No.	Description	Qty
1	HD-27080 (LH)	HANDLE, OFFSET MAG LATCH	1
2	SC-35259	SCREW, M5x0.8x50MM FLAT	4
3	5017230	DOOR, ASSY, SLAB, 1000-S/UP	1
4	SC-22853	SCREW, M5x0.8x30MM FLAT	6
5	HG-22338	HINGE, 1-3/8 OFFSET, PAIR, CHROME	1
6	SC-23868	SCREW, M5x0.8x20MM FLAT	6
7	LK-22567	LOCK, CYLINDER (optional)	1

## 1000-UP Slab Door Package "A", Reach-In

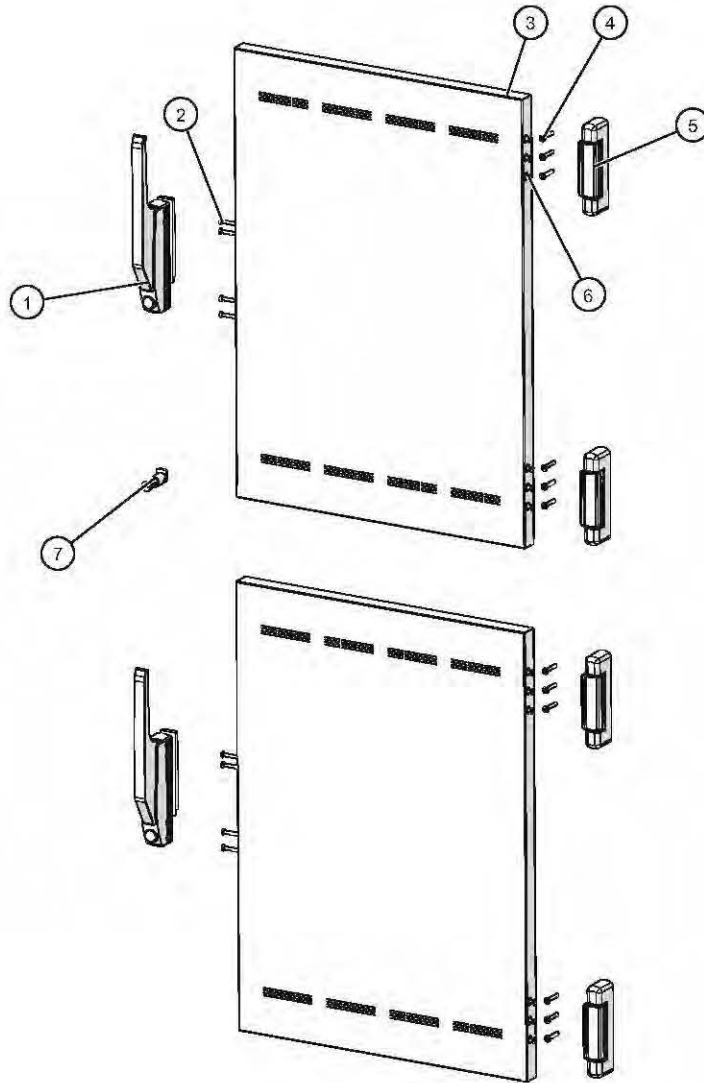

ID	Part No.	Description	Qty
1	HD-27080 (RH)	HANDLE, OFFSET MAG LATCH	2
2	SC-35259	SCREW, M5x0.8X50MM FLAT	8
3	5012801	DOOR ASSY, 1000-S/UP	2
4	SC-22853	SCREW, M5x0.8X30MM FLAT	12
5	HG-22338	HINGE, 1-3/8 OFFSET, PAIR, CHROME	2
6	SC-23868	SCREW, M5x0.8X20MM FLAT	12
7	LK-22567	LOCK, CYLINDER (optional)	1

## 1000-UP Window Door Package "B", Reach-In

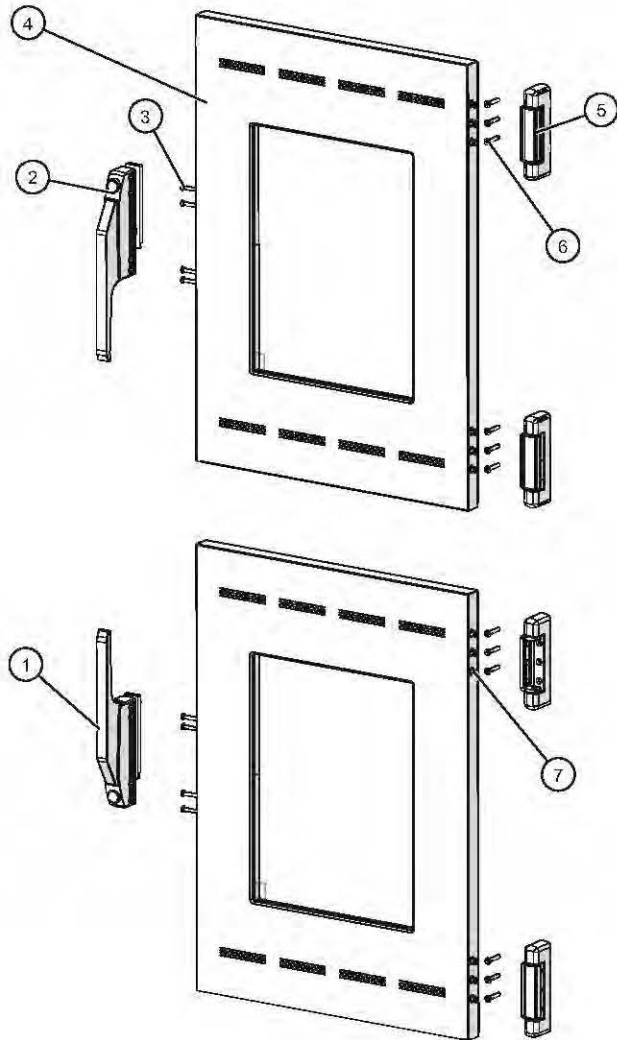

ID	Part No.	Description	Qty
1	HD-27080 (RH)	HANDLE,OFFSET MAG LATCH	1
2	HD-27080 (LH)	HANDLE,OFFSET MAG LATCH	1
3	SC-35259	SCREW,M5x0.8X50MM FLAT	8
4	5012806	DOOR, ASSY, WINDOW, 1000-S/UP	2
5	HG-22338	HINGE, 1-3/8 OFFSET, PAIR, CHROME	2
6	SC-22853	SCREW,M5x0.8X30MM FLAT	12
7	SC-23868	SCREW,M5x0.8X20MM FLAT	12

## 1000-UP Slab Door Package "C", Pass-Thru

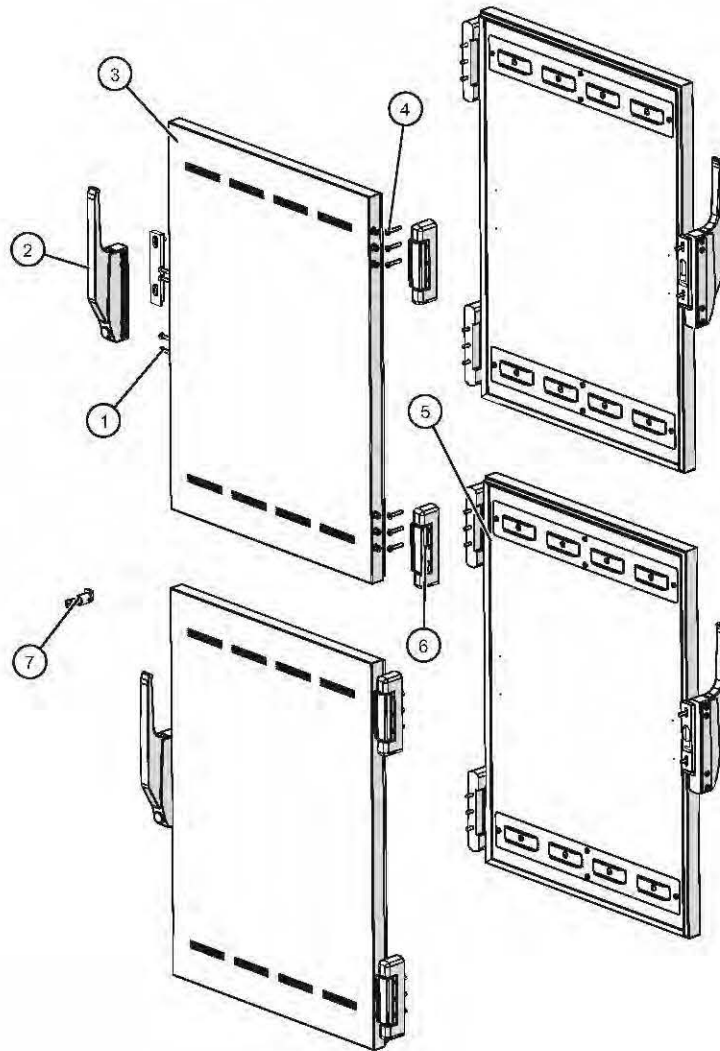

ID	Part No.	Description	Qty
1	SC-35259	SCREW,M5x0.8X50MM FLAT	16
2	HD-27080 (RH)	HANDLE,OFFSET MAG LATCH	4
3	5012801	DOOR, ASSY, 2010	4
4	SC-22853	SCREW,M5x0.8X30MM FLAT	24
5	SC-23868	SCREW,M5x0.8X20MM FLAT	24
6	HG-22338	HINGE, 1-3/8 OFFSET, PAIR, CHROME	4
7	LK-22567	LOCK, CYLINDER (optional)	1

## 1000-UP Window Door Package "D", Pass-Thru

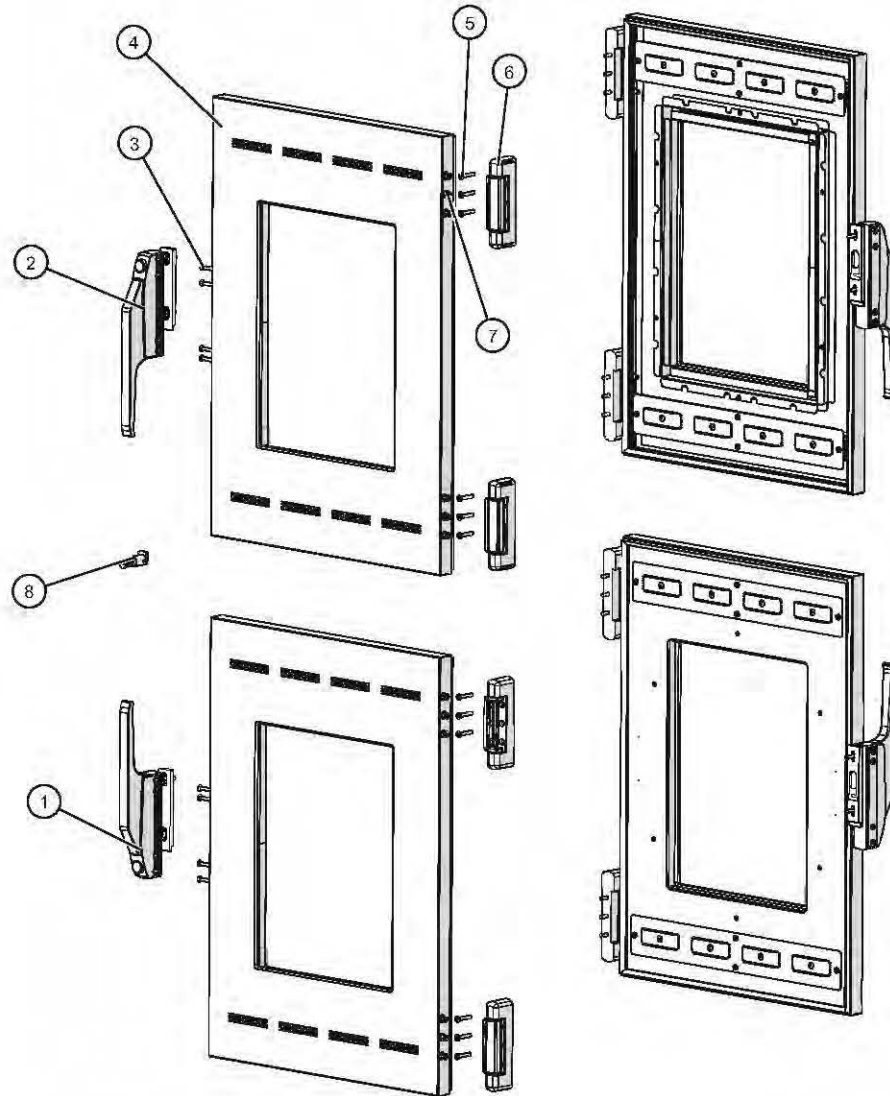

ID	Part No.	Description	Qty
1	HD-27080 (RH)	HANDLE, OFFSET MAG LATCH	2
2	HD-27080 (LH)	HANDLE, OFFSET MAG LATCH	2
3	SC-35259	SCREW, M5x0.8X50MM FLAT	16
4	5012806	DOOR, ASSY, WINDOW, 1000-S/UP	4
5	SC-22853	SCREW, M5x0.8X30MM FLAT	24
6	HG-22338	HINGE, 1-3/8 OFFSET, PAIR, CHROME	4
7	SC-23868	SCREW, M5x0.8X20MM FLAT	24
8	LK-22567	LOCK, CYLINDER (optional)	1

## Control Assembly, Single, Simple

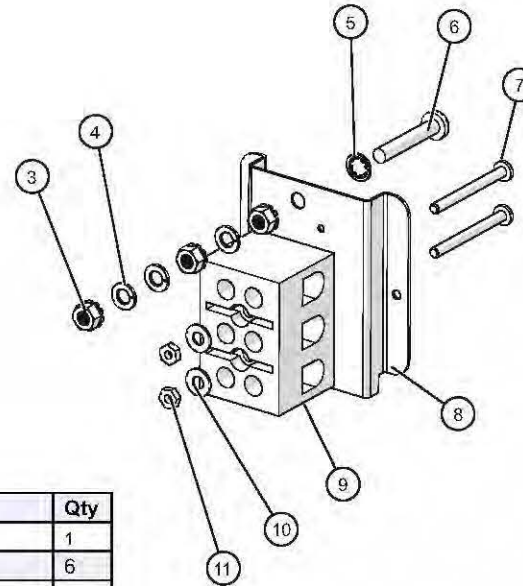
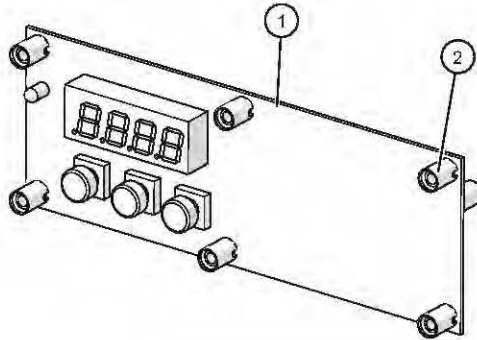

ID	Part No.	Description	Qty
1	CC-34970	LOW COST ELAN WARMER CONTROL	1
2	SP-29392	SPACER, SNAP-IN, 7/16"	6
3	NU-36234	NUT, M5, KEPS	3
4	WS-22301	WASHER, M5 SPLIT LOCK	3
5	WS-2467	WASHER, INT. LOCK	1
6	SC-38128	SCREW, PAN PH, METRIC, M5	1
7	SC-47136	SCREW, 6-32X1-1/2" PAN	2
8	1033464	BRACKET, OFFSET, TERMINAL	1
9	BK-3019	T-BLOCK	1
10	WS-23424	WASHER, FLAT, #8, 18-8 SST	2
11	NU-2361	NUT, 6-32 HEX, S/S	2
12	5034795	WIRESET, SGL CAVITY WARMER (not shown)	1

## Control Assembly, Single, Deluxe with Probe

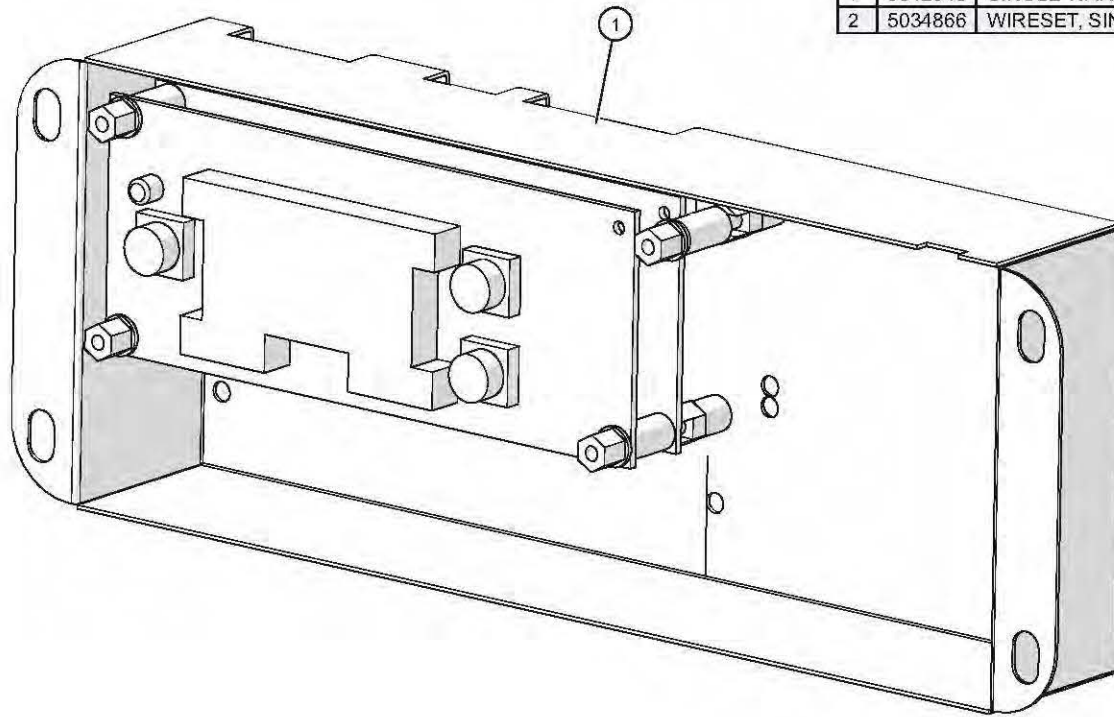

ID	Part No.	Description	Qty
1	5012946	SINGLE WARMER CONTROL	1
2	5034866	WIRESET, SINGLE CAVITY WARMER (not shown)	1

# Control Assembly, Single, Deluxe with Timer

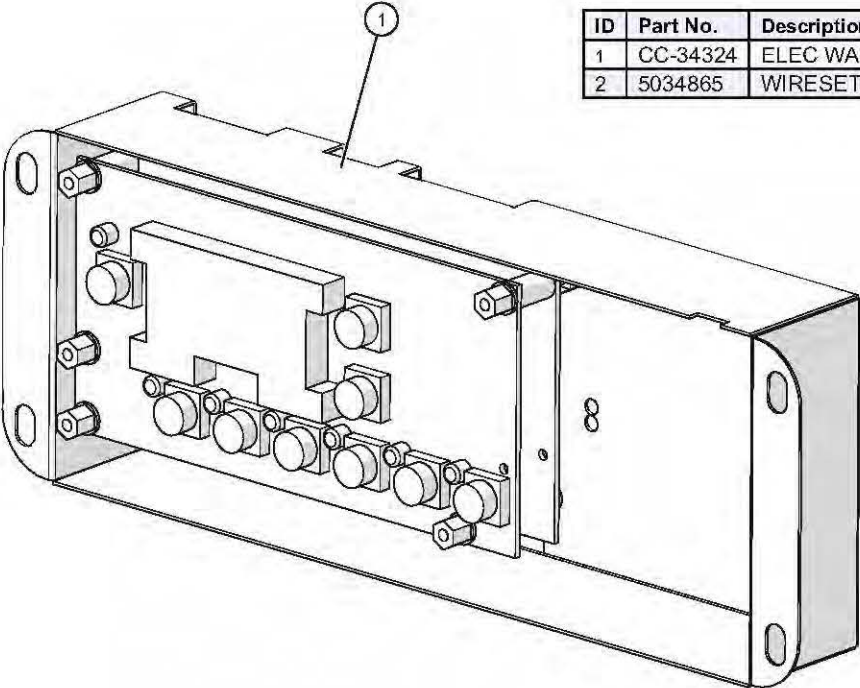

ID	Part No.	Description	Qty
1	CC-34324	ELEC WARMER CONTROL W/ TIMER	1
2	5034865	WIRESET, SINGLE CAVITY WARMER (not shown)	1

## Control Assembly, Double, Deluxe

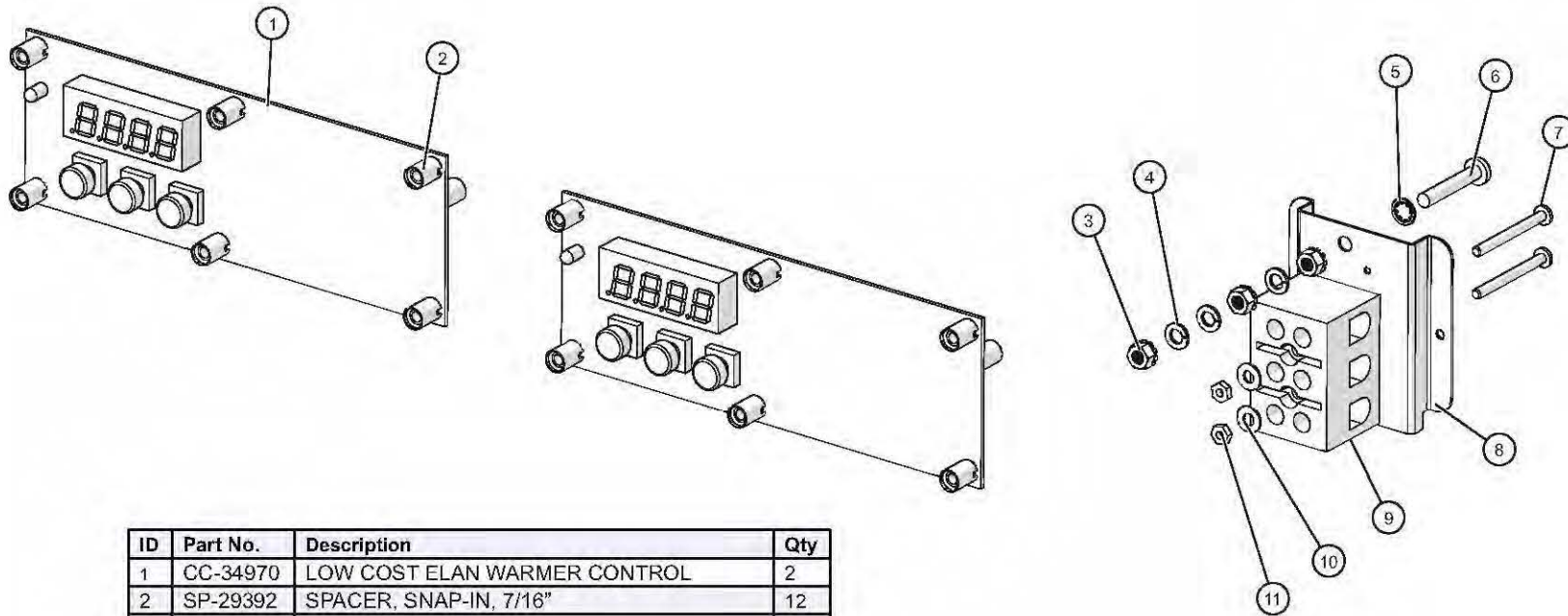

ID	Part No.	Description	Qty
1	CC-34970	LOW COST ELAN WARMER CONTROL	2
2	SP-29392	SPACER, SNAP-IN, 7/16"	12
3	NU-36234	NUT, M5, KEPS	3
4	WS-22301	WASHER, M5 SPLIT LOCK	3
5	WS-2467	WASHER, INT. LOCK	1
6	SC-38128	SCREW,PAN PH, METRIC, M5	1
7	SC-47136	SCREW,6-32X1-1/2" PAN	2
8	1033464	BRACKET,OFFSET,TERMINAL	1
9	BK-3019	T-BLOCK	1
10	WS-23424	WASHER, FLAT, #8, 18-8 SST	2
11	NU-2361	NUT, 6-32 HEX, S/S	2
12	5034795	WIRESET, DBL CAVITY WARMER (not shown)	1

## Control Assembly, Double, Deluxe with Timer

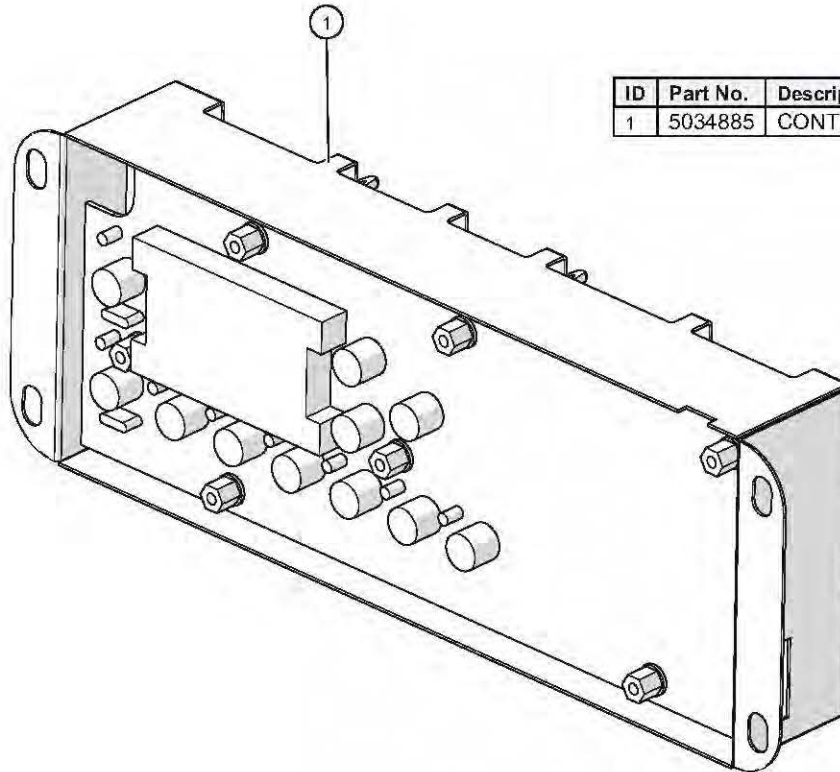

ID	Part No.	Description	Qty
1	5034885	CONTROL W/TIMERS, DUAL WARMER	1

# Control Assembly, Deluxe w/Timer

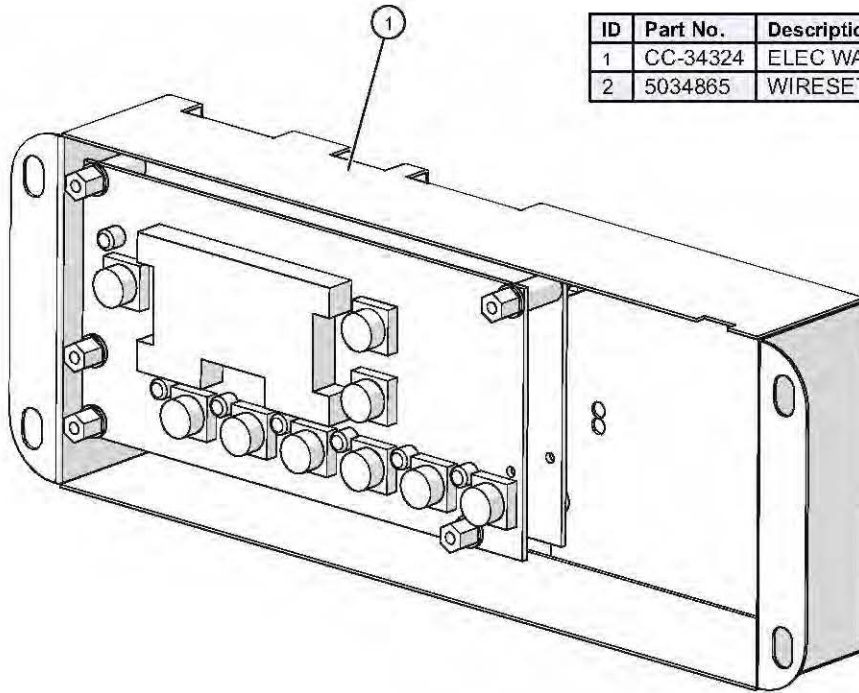

ID	Part No.	Description	Qty
1	CC-34324	ELEC WARMER CONTROL W/ TIMER	1
2	5034865	WIRESET, SINGLE CAVITY WARMER (not shown)	1

# Control Assembly, Deluxe

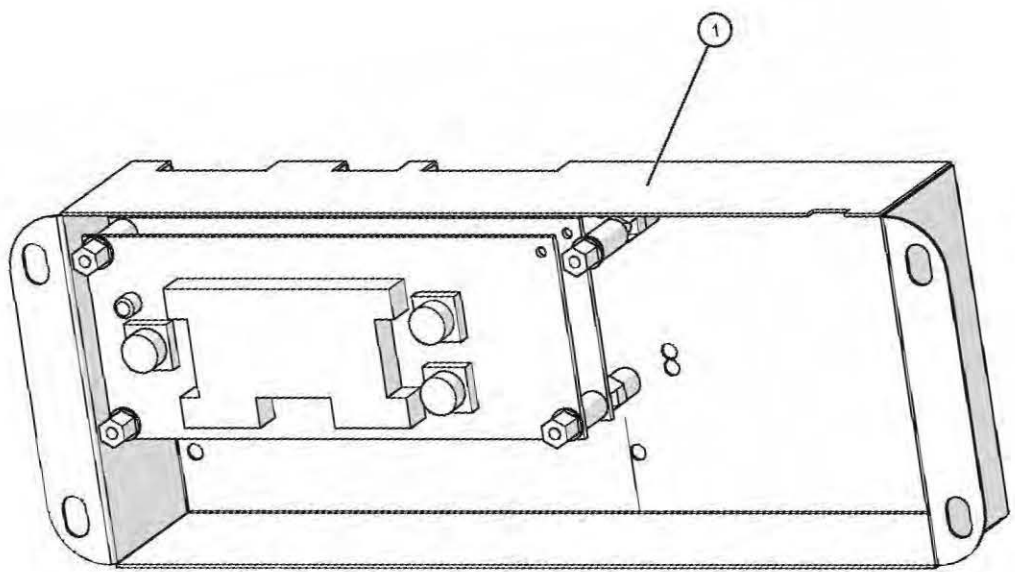

ID	Part No.	Description	Qty
1	5034718	CONTROL, WARMER ASSY, DX	1

# Probe Assembly, Deluxe

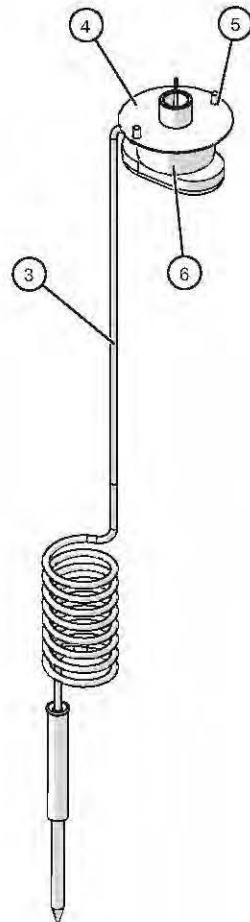
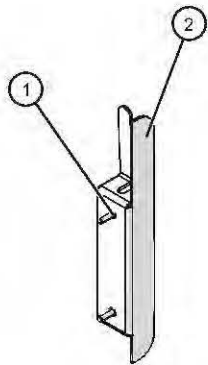

ID	Part No.	Description	Qty
1	RI-27108	RIVET, SEALED	2
2	13239	PROBE HOLDER, TH	1
3	PR-36065	PROBE, QUICK CONNECT, PT100	1
4	5009712	PROBE COVER WELDMENT	1
5	SC-22271	M4 X 6MM PH PAN HD M/S .7	2
6	PR-34705	PROBE, RECEPTACLE, 600MM WIRE	1

## 1000-S Side Rack and Shelves (Domestic)

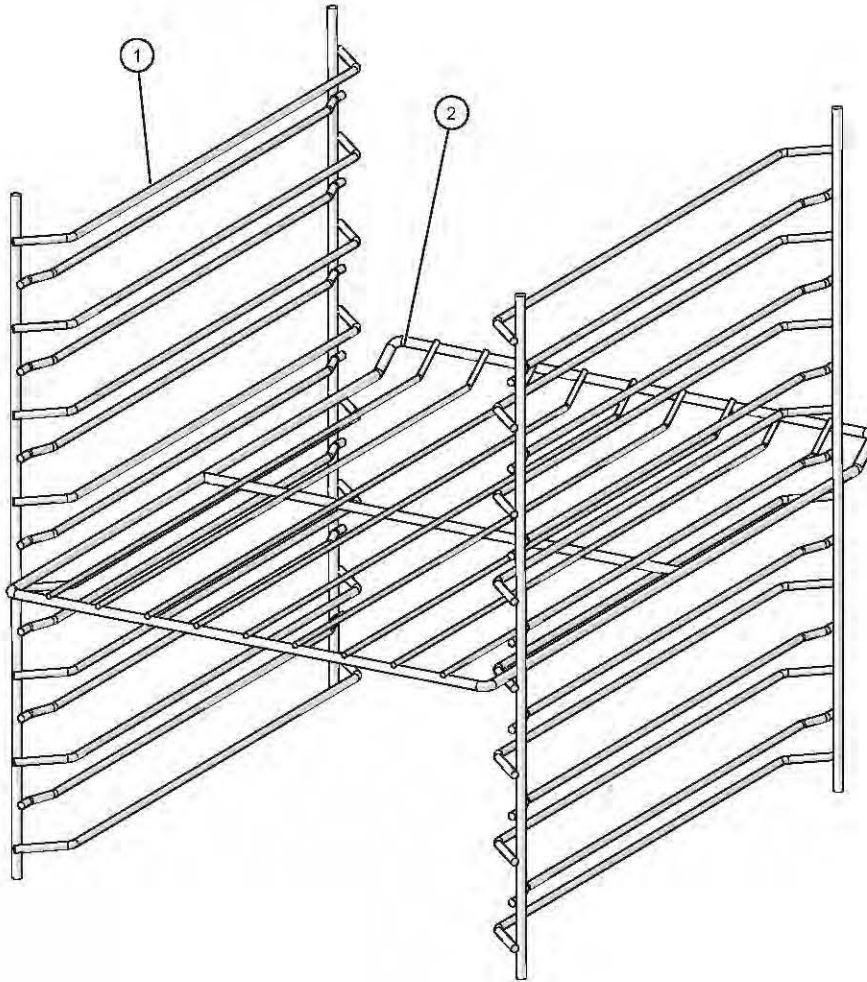

ID	Part No.	Description	Qty
1	SR-2120	1000-S,UP SIDE RACK	2
2	SH-2325	SHELF, S/S, 1000-TH	1

# 1000-UP Proofer Pan Assembly

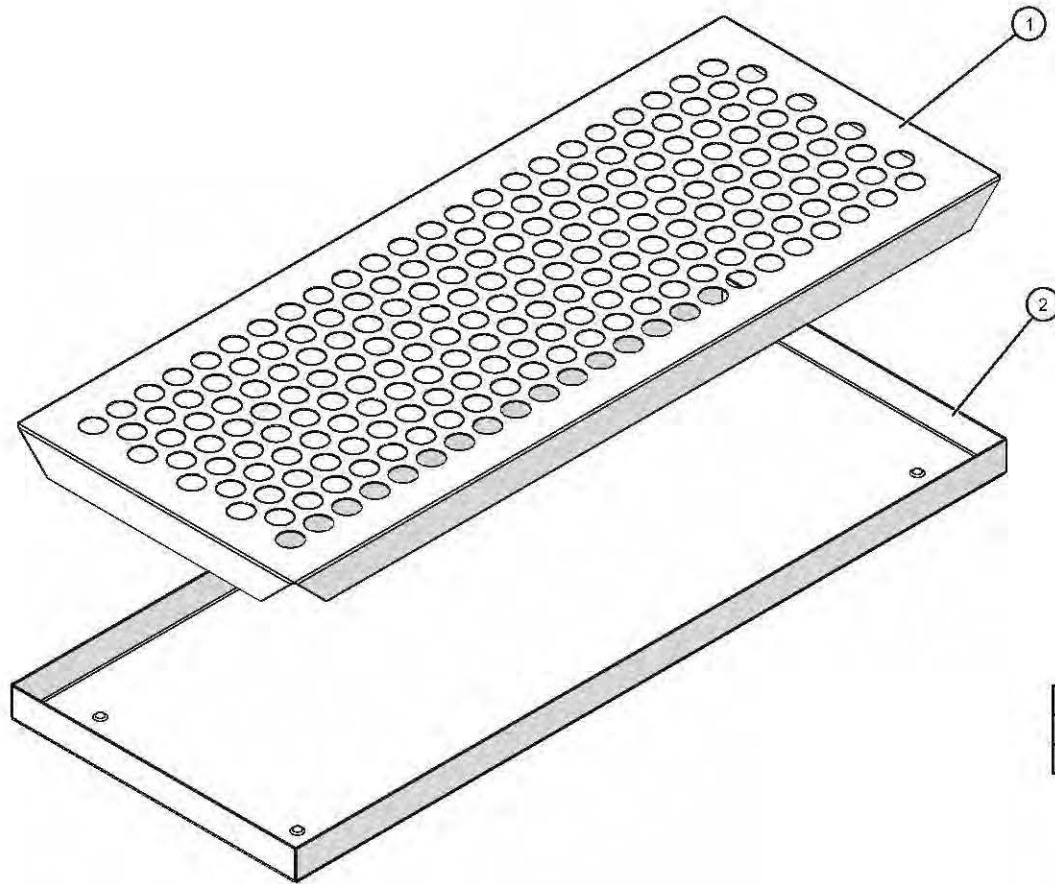

ID	Part No.	Description	Qty
1	1774	PAN COVER	1
2	1775	MOISTURE PAN	1

## Cordset/Ferrule Assembly, NEMA 5-15P

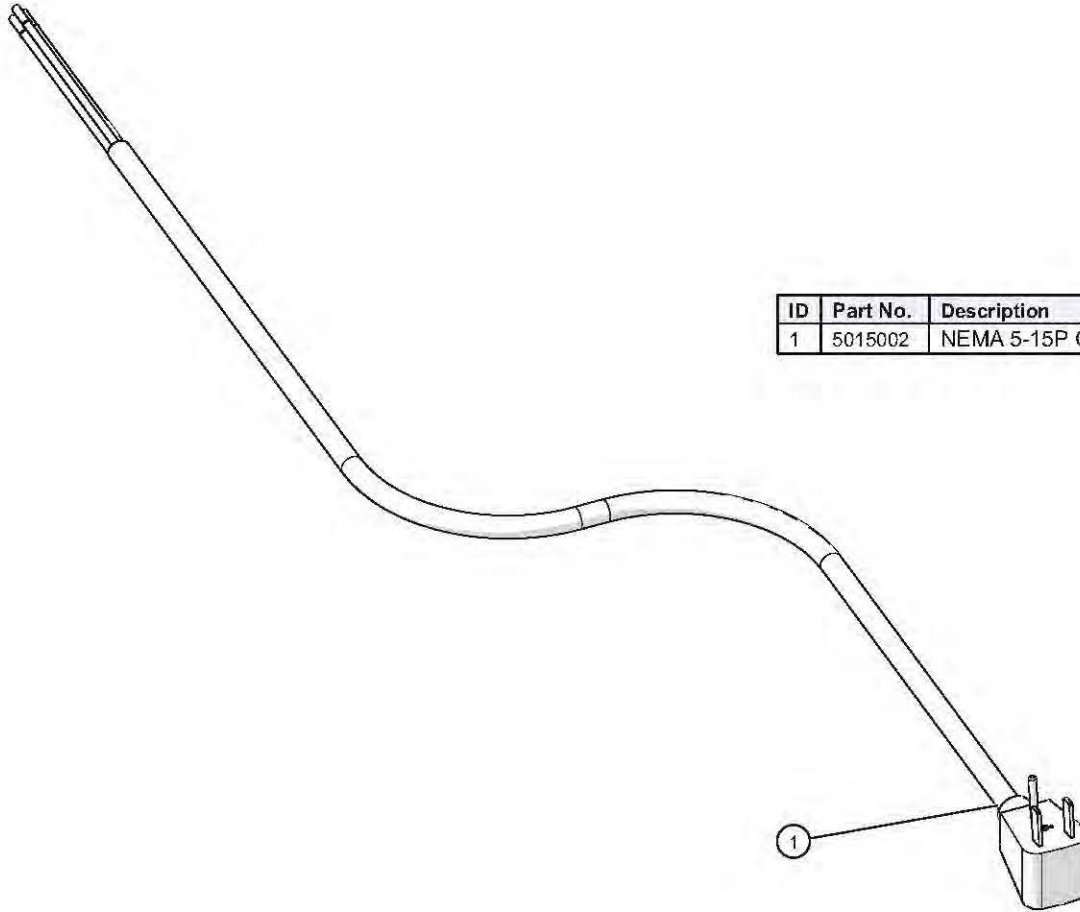

ID	Part No.	Description
1	5015002	NEMA 5-15P CORDSET FERRULE ASSEMBLY

## Cordset/Ferrule Assembly, NEMA 5-20P

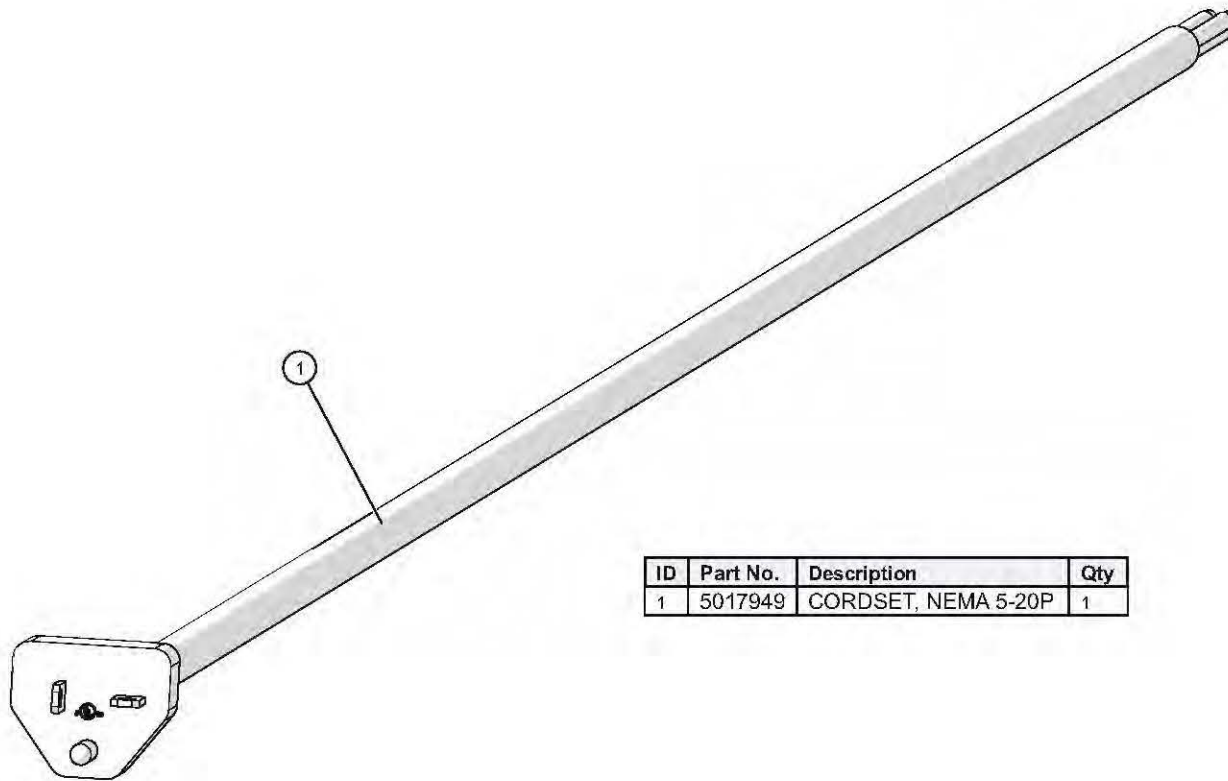

ID	Part No.	Description	Qty
1	5017949	CORDSET, NEMA 5-20P	1

# Cord, 12/3 with Ferrules, 12'

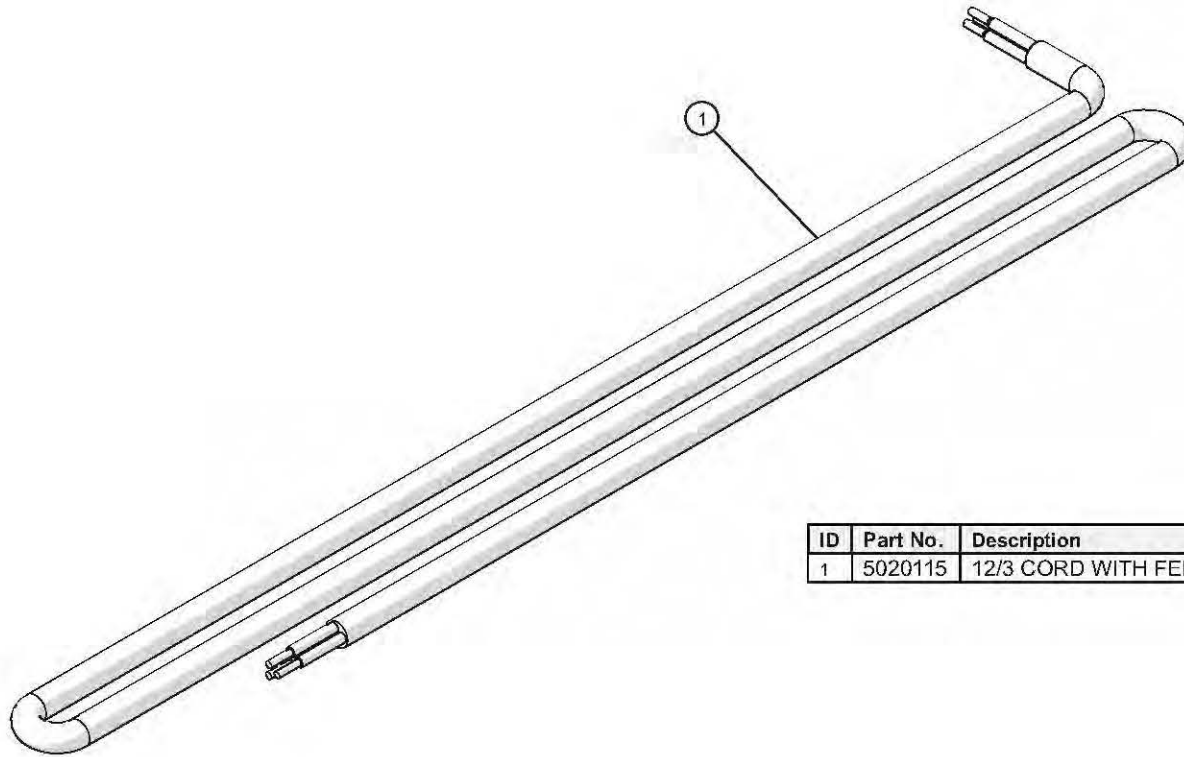

ID	Part No.	Description	Qty
1	5020115	12/3 CORD WITH FERRULES, 12'	1

## Cordset/Ferrule Assembly, SAA AS 3112-16P

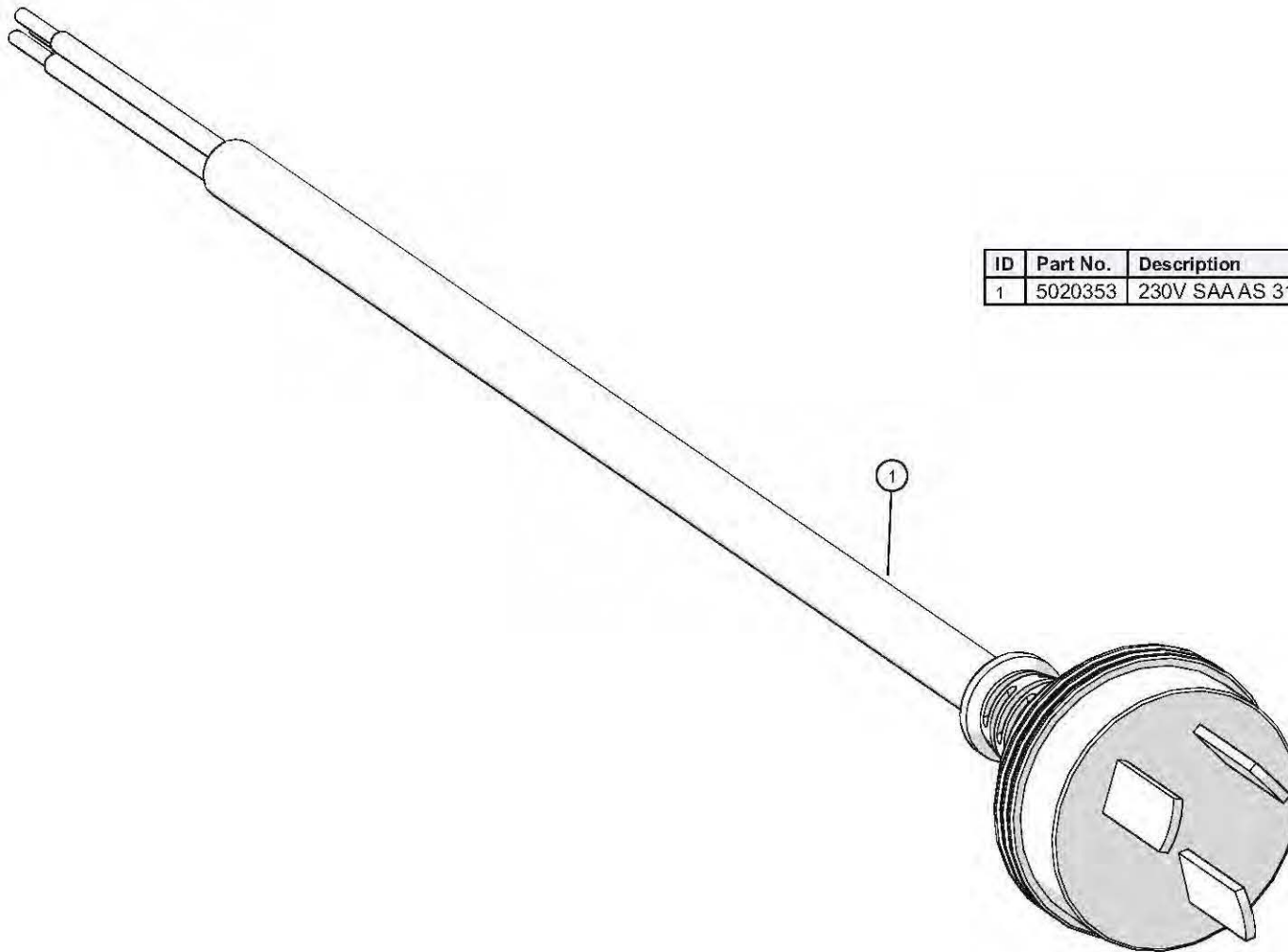

ID	Part No.	Description	Qty
1	5020353	230V SAA AS 3112-16P CORDSET	1

## Cordset Assembly, AS/NZS 3112

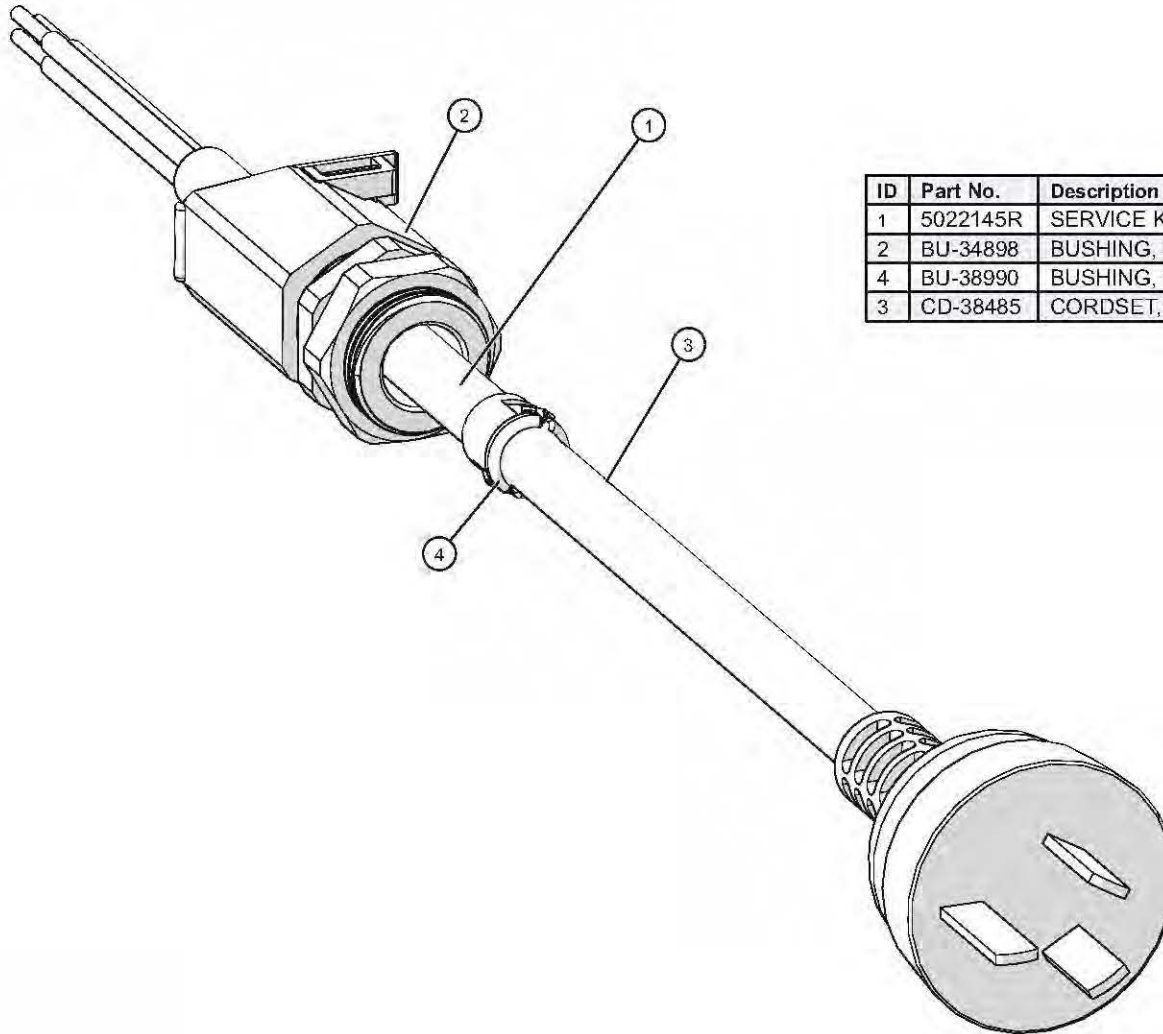

ID	Part No.	Description	Qty
1	5022145R	SERVICE KIT, CORDSET,10A-250V	1
2	BU-34898	BUSHING, STRAIN RELIEF, 90°, BLK	1
4	BU-38990	BUSHING, SNUB, 3/16" CABLE	1
3	CD-38485	CORDSET,10A-250V	1

## Cordset Assembly, AS/NZS 3112 2000

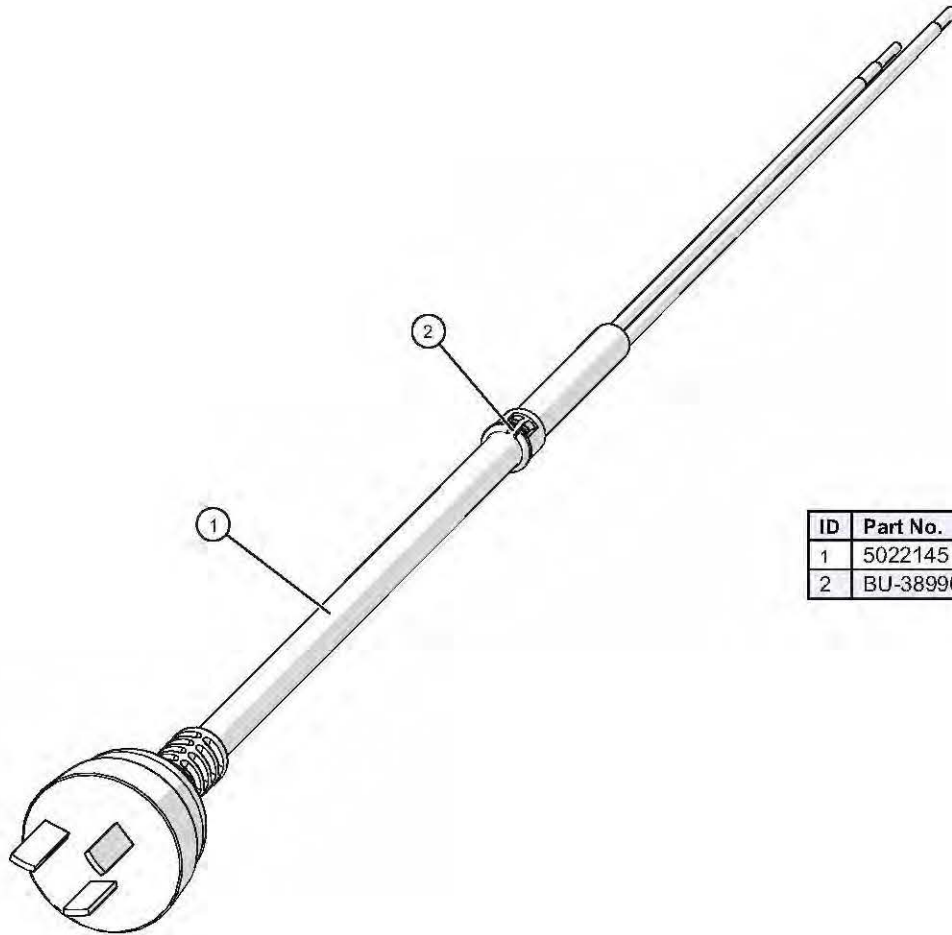

ID	Part No.	Description	Qty
1	5022145	CORDSET,10A-250V,AS/NZS 3112:2000	1
2	BU-38990	BUSHING, SNUB, 3/16" CABLE	1

# Cordset/Ferrule Assembly, NEMA 6-15P

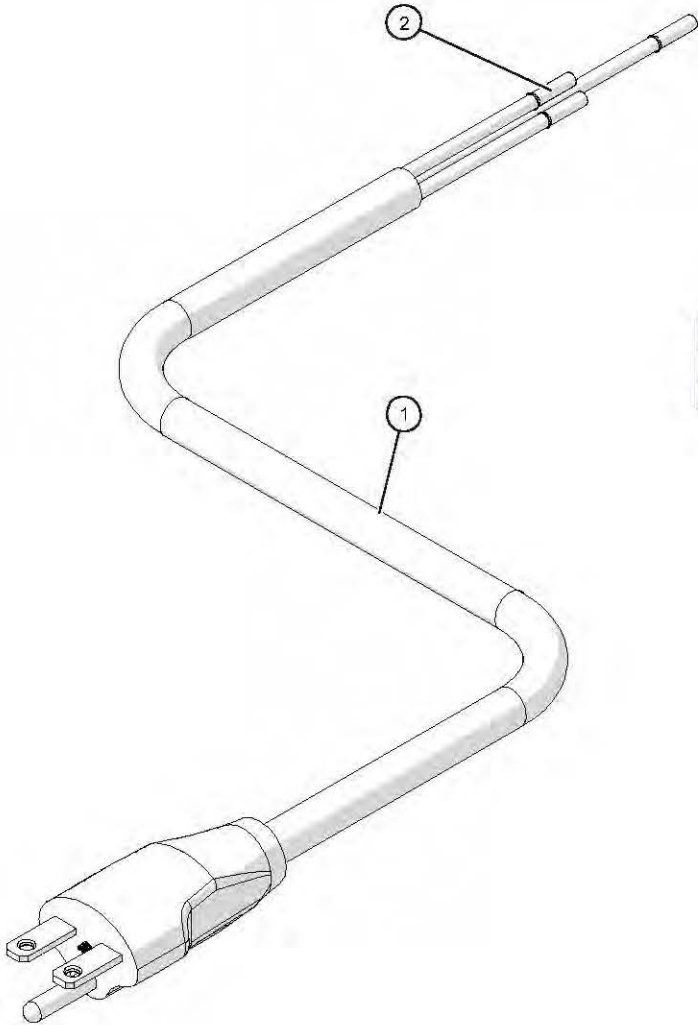

ID	Part No.	Description
1	CD-3551	CORDSET, 14/3 SJTO, 250V
2	CR-34829	CONNECTOR, #14 FERRULE

## Cordset/Ferrule Assembly, CEE-7/7

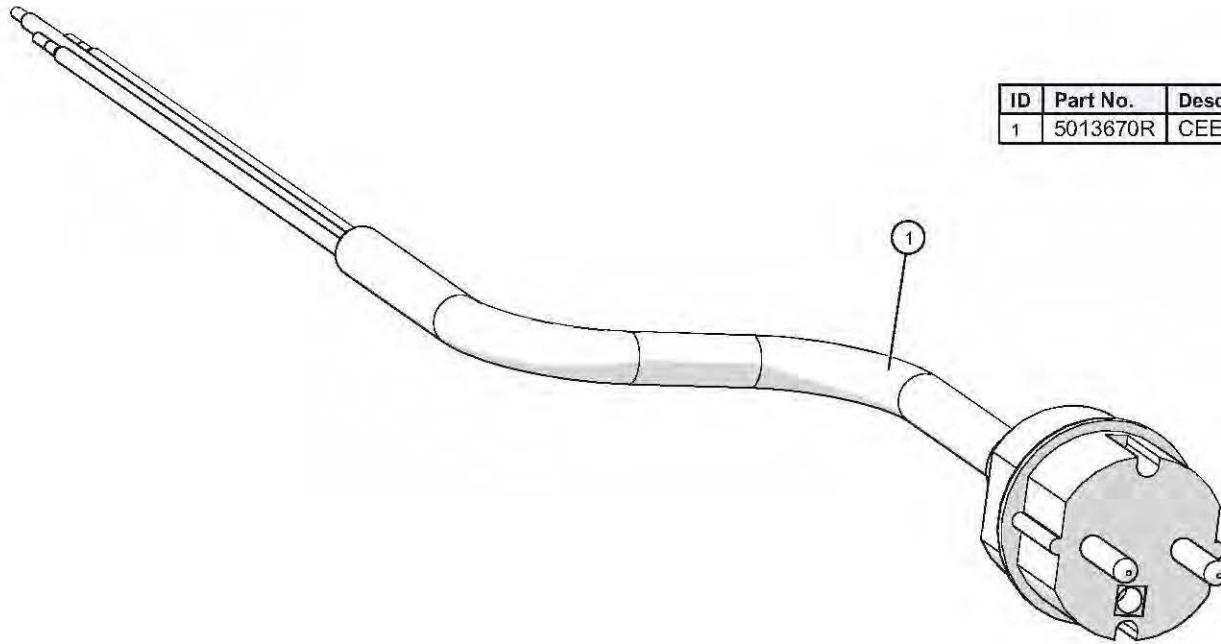

ID	Part No.	Description	Qty
1	5013670R	CEE 7/7 CORDSET FERRULE ASSEMB	1

## Cordset/Ferrule Assembly, BS 1363

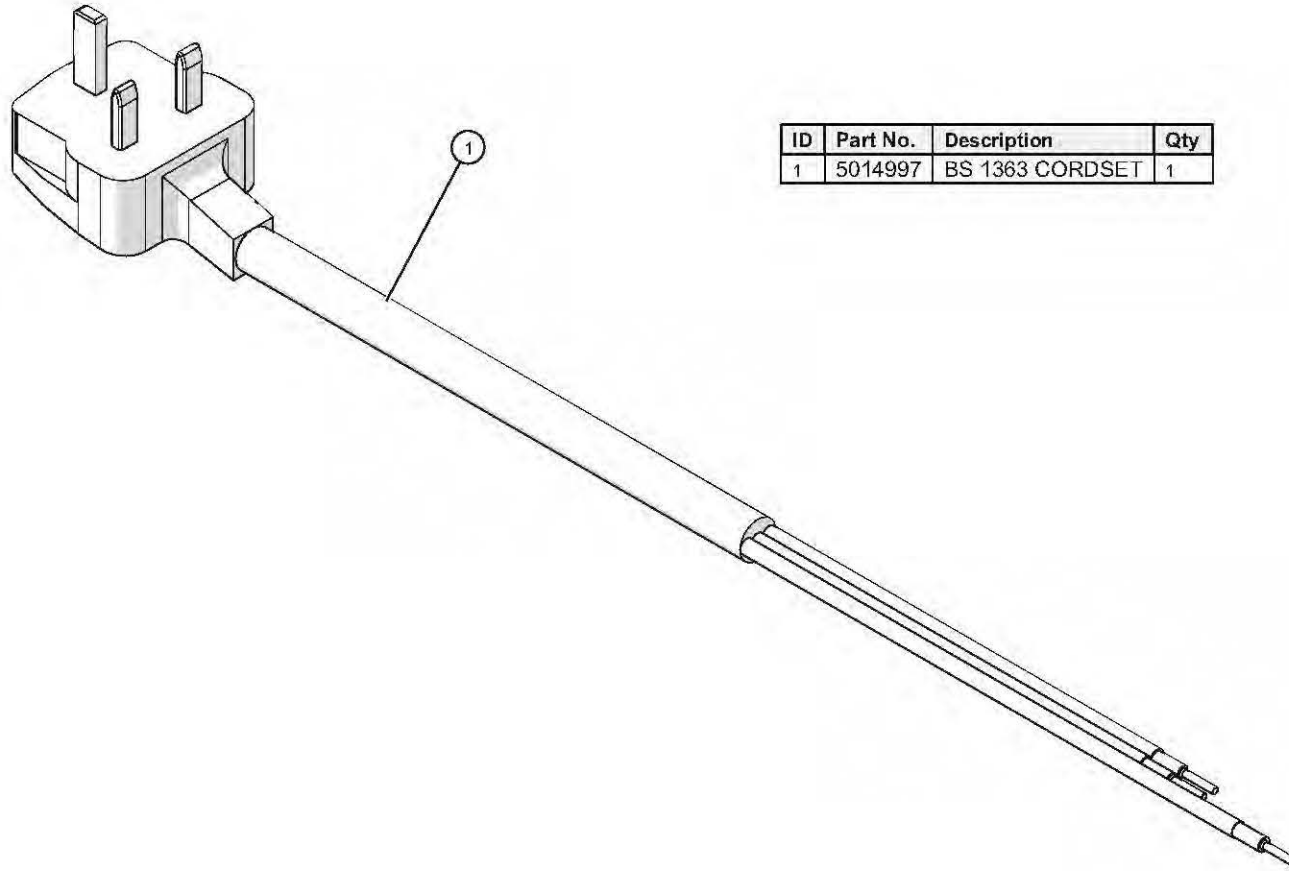

ID	Part No.	Description	Qty
1	5014997	BS 1363 CORDSET	1

## Caster Package, 2-1/2"

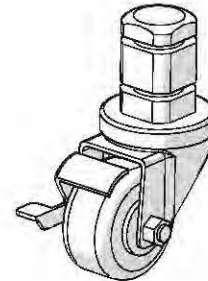
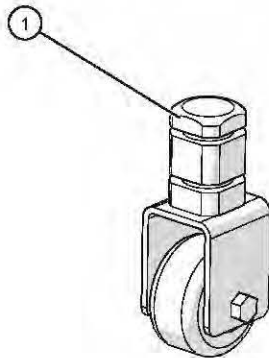
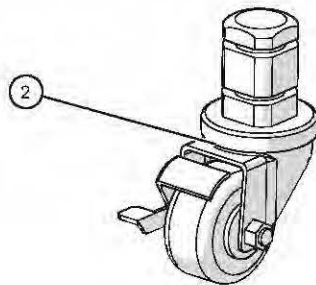

ID	Part No.	Description	Qty
1	CS-38265	CASTER, RIGID 2.5", 1.5" STEM	2
2	CS-38264	CASTER, SWIVEL 2.5", 1.5" STEM	2

## Caster Package, 2-1/2", All Swivel

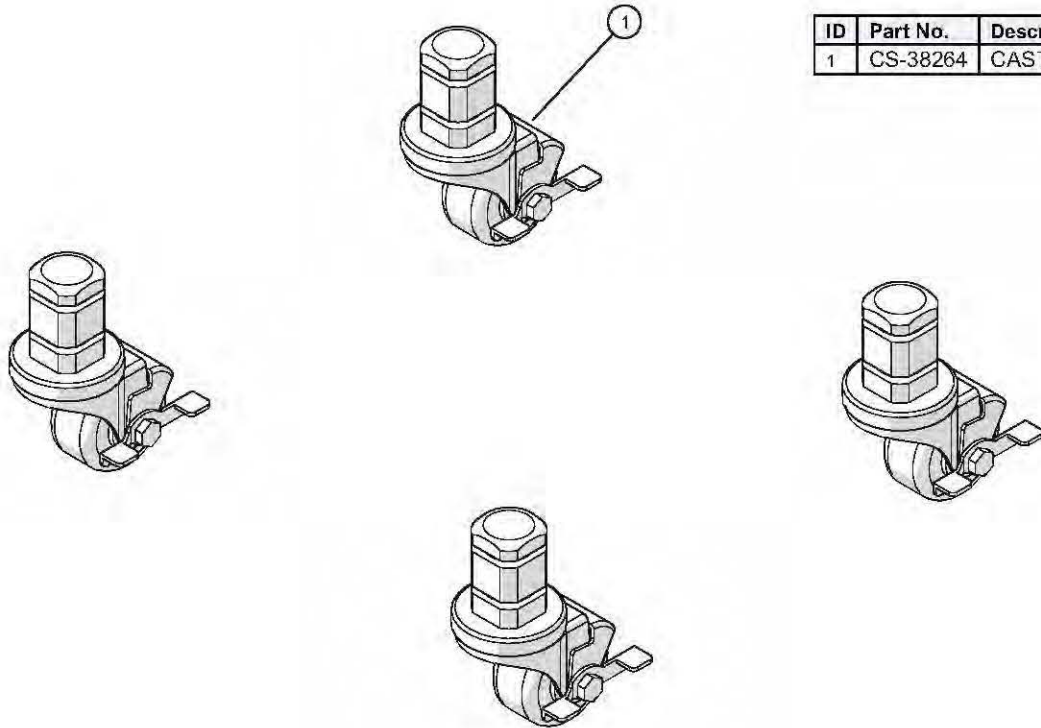

ID	Part No.	Description
1	CS-38264	CASTER, SWIVEL 2.5", 1.5" STEM

## Caster Package, 3-1/2"

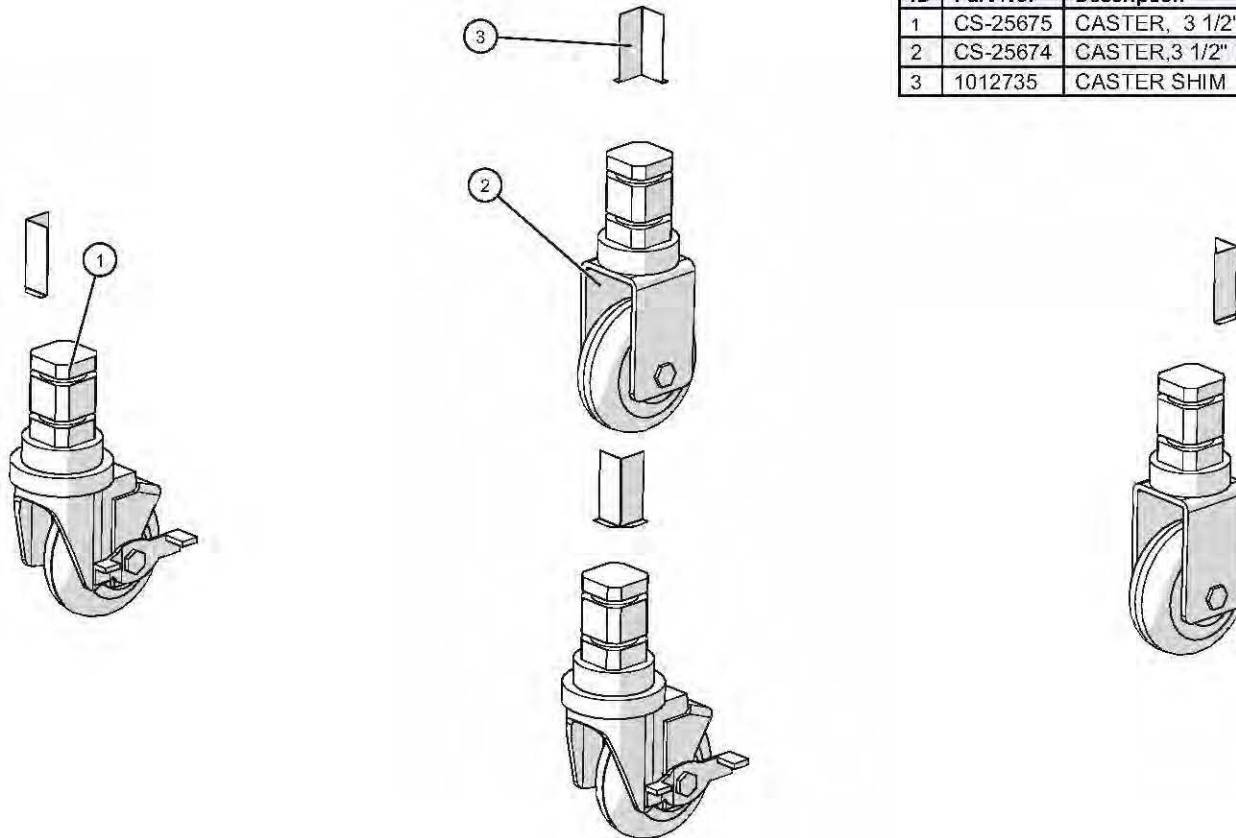

ID	Part No.	Description	Qty
1	CS-25675	CASTER, 3 1/2" SWIVEL W/ BRAKE	2
2	CS-25674	CASTER, 3 1/2" RIGID	2
3	1012735	CASTER SHIM	4

# Caster Package, 5"

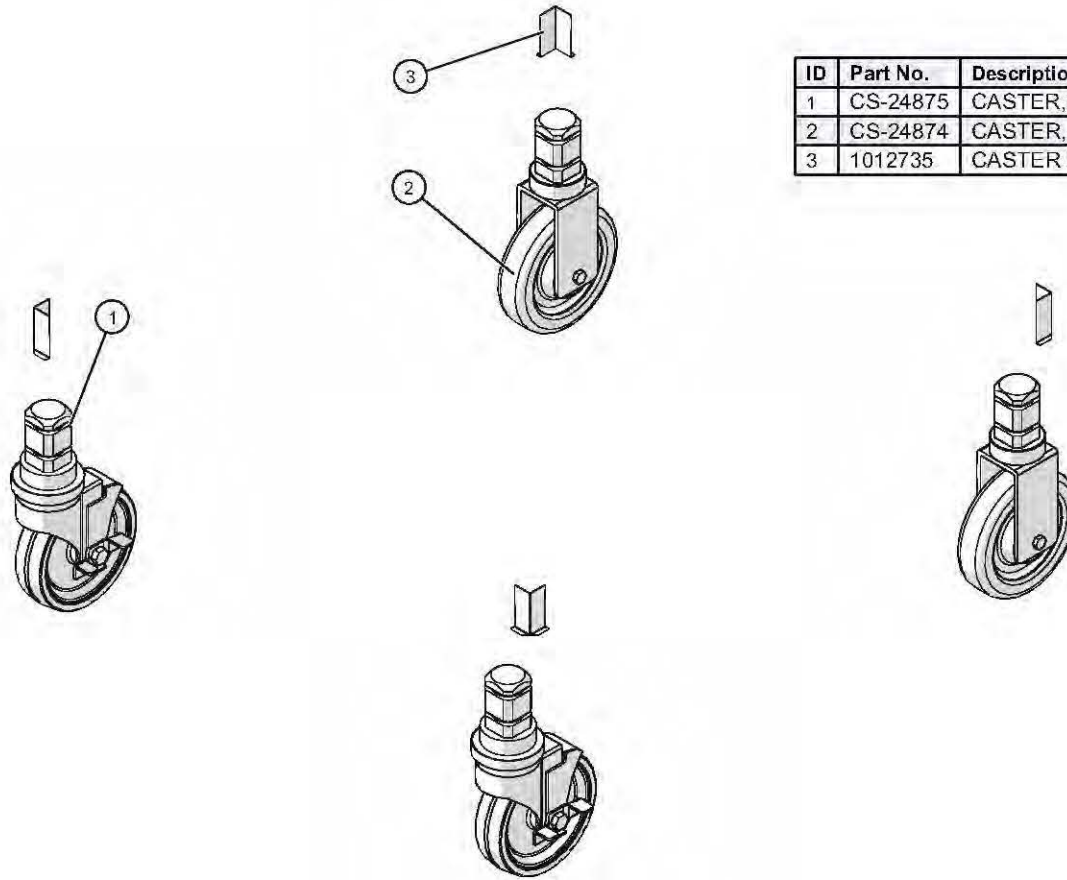

ID	Part No.	Description	Qty
1	CS-24875	CASTER, 1.5" STEM, 5" SWIV WHL	2
2	CS-24874	CASTER, 5" RIGID, 1.5" STEM	2
3	1012735	CASTER SHIM	4

## Caster Package, 5" (all swivel)

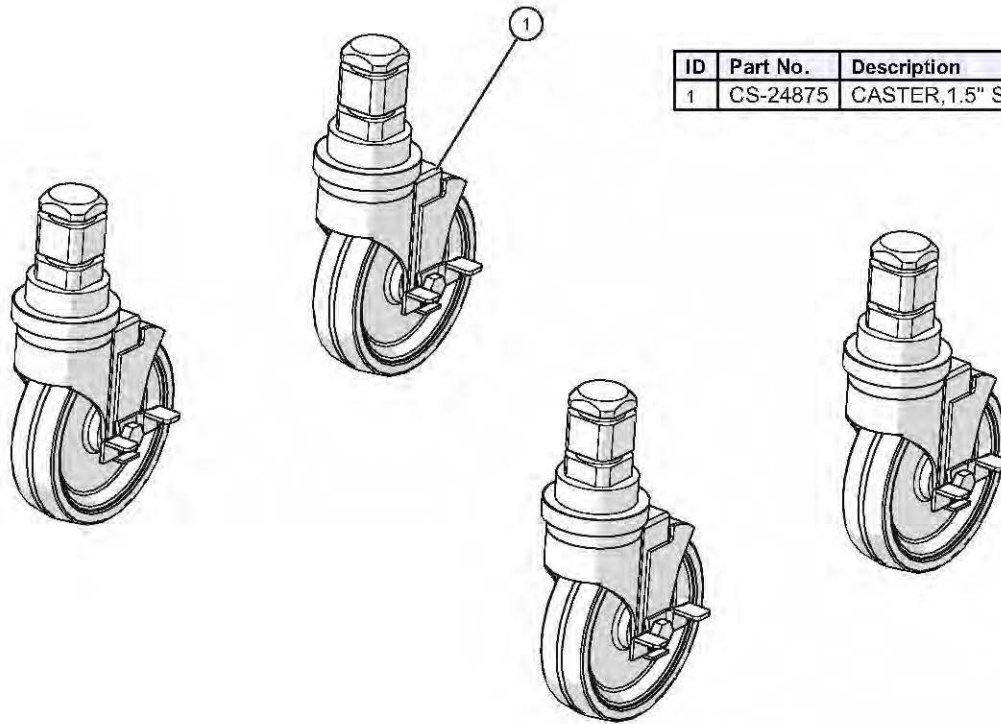

ID	Part No.	Description
1	CS-24875	CASTER, 1.5" STEM, 5" SWIV WHL

## Leg Package, 6"

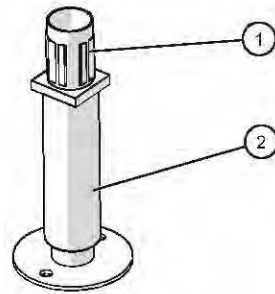

ID	Part No.	Description	Qty
2	LG-23067	6" LEG W/ ADJUSTABLE FLANGED FOOT	4
1	LG-37094	LEG, ADJUST, FOOTING	4

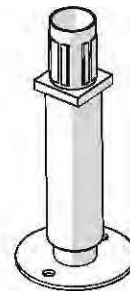
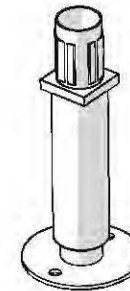
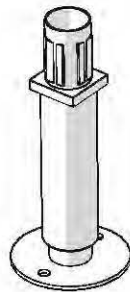



# ALTO-SHAAM.

Menomonee Falls, WI U.S.A.

Phone 800-558-8744 | +1-262-251-3800 | [alto-shaam.com](http://alto-shaam.com)

## ASIA

Shanghai, China  
Phone +86-21-6173-0336

## AUSTRALIA

Brisbane, Queensland  
Phone 800-558-8744

## CANADA

Concord, Ontario Canada  
Toll Free Phone 866-577-4484  
Phone +1-905-660-6781

## FRANCE

Aix en Provence, France  
Phone +33[0]4-88-78-21-73

## GMBH

Bochum, Germany  
Phone +49 [0]234 298798-0

## ITALY

Padua, Italy  
Phone +39 3476073504

## INDIA

Pune, India  
Phone +91 9657516999

## MEXICO

Phone +52 1 477-717-3108

## MIDDLE EAST & AFRICA

Dubai, UAE  
Phone +971-4-321-9712

## CENTRAL & SOUTH AMERICA

Miami, FL USA  
Phone +1 954-655-5727