



Hot Food Holding Cabinets

1200-S
1200-UP



Units built December 2023—March 2025

Manufacturer's Information

Copyright

© Copyright 12/23 by Alto-Shaam, Inc.
 All rights reserved.
 This manual or any portion thereof may not be reproduced or used in any manner whatsoever without the express written permission of Alto-Shaam, Inc.

Trademarks

All trademarks referenced in this documentation are the property of their respective owners.

Manufacturer

Alto-Shaam, Inc.
 P.O. Box 450
 W164 N9221 Water Street
 Menomonee Falls, WI 53052

Models Covered

1200-S 1200-UP	Heated Holding Cabinets
-------------------	-------------------------

Serial Number

The unit serial number is required for identifying and ordering the correct service parts.
 Record the unit serial number below for reference.

Serial Number

Parts Finder Tool

Interactive diagrams from this Parts Manual are available online at our Parts Finder Tool:
<https://www.alto-shaam.com/en/customer-support/parts>.
 Or, scan the QR code below.



Parts Ordering Information

Original manufacturer's replacement parts may be ordered directly from the Alto-Shaam network of Authorized Service Agents and Parts Distributors. Follow this link for a map to a local partner: <https://www.alto-shaam.com/en/how-to-buy>. If you are an Authorized Service Agent or Parts Distributor, please submit your purchase order to parts@alto-shaam.com.

Non-OEM parts may be substituted; however, these parts must be of equal quality and specifications as those provided by Alto-Shaam.

Table of Contents

Manufacturer's Information.....	2	1200-S Bonnet Package "D", 230V Manual.....	45
Table of Contents	3	1200-S Bonnet Package "E", 230V 2000W Manual	46
1200-S Exterior Panel Package "A", Reach-In	5	1200-S Bonnet Package "F", 120V Electronic.....	47
1200-S Exterior Panel Package "B", Pass-Thru	6	1200-S Bonnet Package "G", 208V-240V Electronic.....	48
1200-UP Exterior Panel Package "A", Reach-In	7	1200-S Bonnet Package "I", 230V Electronic	49
1200-UP Exterior Panel Package "B", Pass-Thru	8	1200-S Bonnet Package "J", 230V 1850W Electronic.....	50
1200-UP Exterior Panel Package "C", Pass-Thru	9	1200-S Bonnet Package "K", 120V Electronic w/Timer	51
1200-UP Exterior Panel Package "D", Pass-Thru w/Recessed Handles.....	10	1200-S Bonnet Package "N", 230V Electronic w/Timer	52
1200-UP PT Counterweight Kit.....	11	1200-S Bonnet Package "O", 230V Elec w/Timer, 1850W	53
1200-S/-UP Bumper Assembly	12	1200-S Bonnet Package "S", 230V Electronic w/Probe.....	54
Security Panel (optional).....	13	1200-UP Bonnet Package "A", 120V Manual	55
1200-S Core Assembly, Reach-In, Simple	14	1200-UP Bonnet Package "B", 208V-240V Manual	56
1200-S Core Assembly, Pass-Thru, Simple	15	1200-UP Bonnet Package "C", 208V-240V 4000W Manual	57
1200-S Core Assembly, Reach-In, Simple, 2000W	16	1200-UP Bonnet Package "D", 230V Manual	58
1200-S Core Assembly, Reach-In, Deluxe w/Timer.....	17	1200-UP Bonnet Package "E", 230V 3700W Manual.....	59
1200-UP Core Assembly, Reach-In, Simple	18	1200-UP Bonnet Package "F", 120V Electronic.....	60
1200-UP Core Assembly, Reach-In, 2000W Simple	19	1200-UP Bonnet Package "G", 208V-240V Electronic.....	61
1200-UP Core Assembly, Pass-Thru, Simple.....	20	1200-UP Bonnet Package "H", 208V-240V 4000W Electronic.....	62
1200-UP Core Assembly, Pass-Thru, 2000W Simple.....	21	1200-UP Bonnet Package "I", 230V Electronic	63
1200-UP Core Assembly, Reach-In, 2000W Deluxe	22	1200-UP Bonnet Package "J", 230V 3700W Electronic.....	64
1200-UP Core Assembly, Reach-In, Deluxe	23	1200-UP Bonnet Package "K", 120V Electronic w/Timer	65
1200-UP Core Assembly, Pass-Thru, Deluxe	24	1200-UP Bonnet Package "N", 230V Electronic w/Timer	66
1200-UP Core Assembly, Pass-Thru, Deluxe with Timer.....	25	1200-UP Bonnet Package "O", 230V 3700W Electronic w/Timer	67
1200-UP Core Assembly, Pass-Thru, 2000W Deluxe	26	1200-UP Bonnet Package "P", 120V Electronic w/Probe.....	68
1200-UP Core Assembly, Reach-In, Deluxe with Timer	27	1200-UP Bonnet Package "Q", 208V-240V Electronic w/Probe	69
1200-UP Core Assembly, Reach-In, Deluxe with Timer	28	1200-UP Bonnet Package "S", 230V Electronic w/Probe.....	70
1200-UP Core Assembly, Pass-Thru, Deluxe 2000W	29	1200-UP Bonnet Package "U", 120V Electronic w/Probe & Timer	71
1200-UP Core Assembly, Pass-Thru w/Timer, Deluxe 2000W.....	30	1200-UP Bonnet Package "X", 230V Electronic w/Probe & Timer	72
1200-UP Core Assembly, Reach-In, 2000W Deluxe w/Timer.....	31	1200-S Chassis Assembly, 120V Simple	73
Heating Wire Service Kits.....	32	1200-S Chassis Assembly, 120V Simple	74
1200-S Cavity Package "A", Reach-In	33	1200-S Chassis Assembly, 208V-240V Simple	75
1200-S Cavity Package "B", Pass-Thru	34	1200-S Chassis Assembly, 230V Simple	76
1200-S Cavity Package "C", Reach-In 2000W	35	1200-S Chassis Assembly, 208V-240V Deluxe.....	77
1200-S Cavity Package "D", Pass-Thru 2000W	36	1200-S Chassis Assembly, 230V Deluxe.....	78
1200-UP Cavity Package "A", Reach-In	37	1200-S Chassis Assembly, Deluxe (5034305)	79
1200-UP Cavity Package "B", Pass-Thru	38	1200-UP Chassis Assembly, 120V Electronic.....	80
1200-UP Cavity Package "C", Reach-In 4000W	39	1200-UP Control Assembly, 120V Manual.....	81
1200-UP Cavity Package, Pass-Thru 4000W	40	1200-UP Chassis Assembly, 208V-240V Electronic.....	82
1200-UP Cavity Package "I", Pass-Thru 4000W	41	1200-UP Chassis Assembly, 230V Electronic.....	83
1200-S Bonnet Package "A", 120V Manual	42	1200-UP Chassis Assembly, 2000W Electronic	84
1200-S Bonnet Package "B", 208V-240V Manual.....	43	1200-UP Chassis Assembly, 230V 3700W Electronic.....	85
1200-S Bonnet Package "C", 208V-240V 2000W Manual.....	44	1200-UP Chassis Assembly, 208V-240V 4000W Manual.....	86

TABLE OF CONTENTS

1200-UP Chassis Assembly, 208V-240V 4000W Electronic	87
Control Assembly, Single, Simple	88
Control Assembly, Double, Simple	89
Control Assembly, Deluxe Electronic w/Probe.....	90
Control Assembly, Deluxe Electronic w/Timer	91
Control Assembly, Double, Deluxe w/Probe & Timer	92
1200-S Slab Door Package "A", Reach-In	93
1200-S Window Door Package "B", Reach-In	94
1200-S Slab Door Package "C", Pass-Thru	95
1200-S Window Door Package "D", Pass-Thru	96
1200-UP Slab Door Package "A", Reach-In	97
1200-UP Window Door Package "B", Reach-In.....	98
1200-UP Slab Door Package "C", Pass-Thru	99
1200-UP Window Door Package "D", Pass-Thru	100
1200-S Side Rack Package, Chrome Shelves	101
1200-S Side Rack Package, Stainless Shelves	102
1200-UP Side Rack Package, Chrome Shelves	103
Cordset/Ferrule Assembly, NEMA 5-15P	104
Cordset/Ferrule Assembly, NEMA 5-20P	105
Cord, 12/3 with Ferrules, 12'	106
Cordset/Ferrule Assembly, SAA AS 3112-16P.....	107
Cordset Assembly, AS/NZS 3112.....	108
Cordset Assembly, AS/NZS 3112 2000	109
Cordset/Ferrule Assembly, NEMA 6-15P	110
Cordset/Ferrule Assembly, CEE-7/7.....	111
Cordset/Ferrule Assembly, BS 1363	112
Cordset/Ferrule Assembly, CH2-16P	113
Probe Assembly, Deluxe	114
Caster Package, 2-1/2"	115
Caster Package, 3-1/2"	116
Caster Package, 5"	117
Caster Package, 5" (all swivel)	118
Flanged Leg Option, 6"	119
Plug Assembly, Tether Bracket	120

1200-S Exterior Panel Package "A", Reach-In

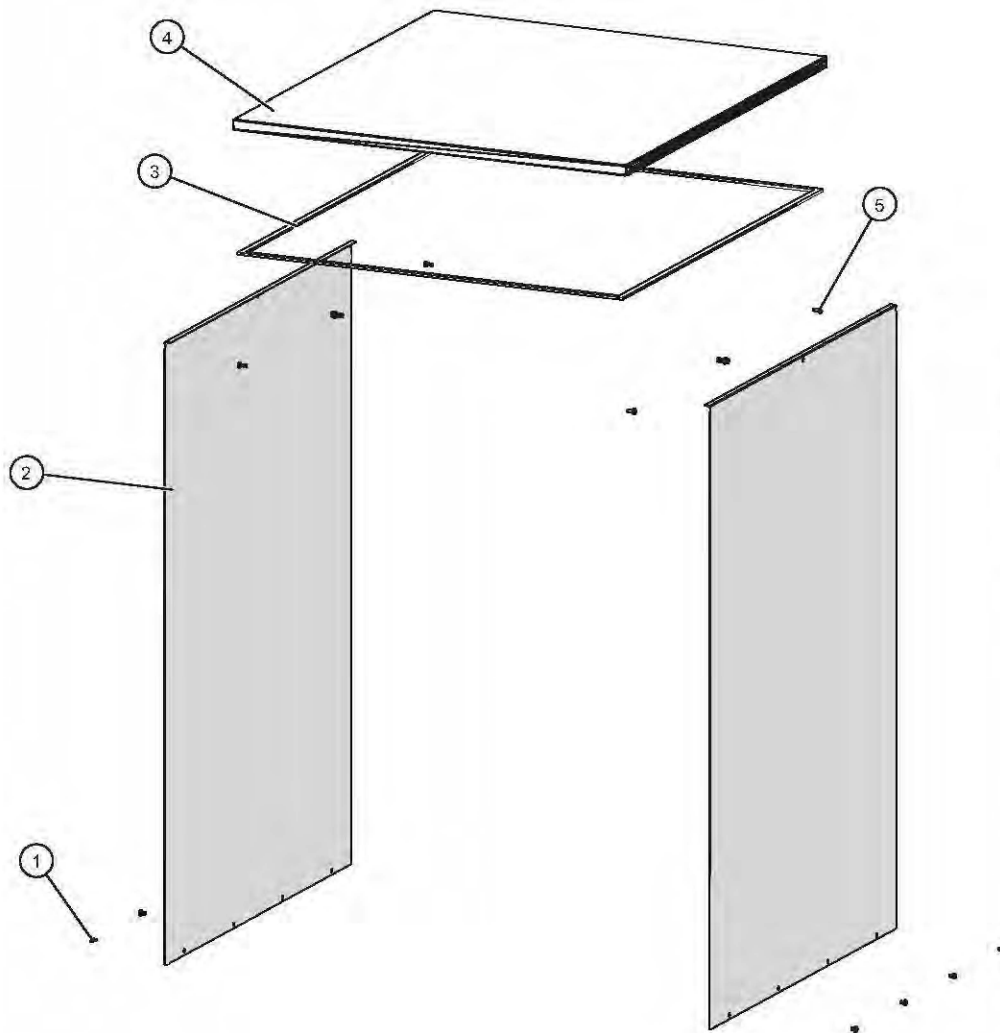

ID	Part No.	Description	Qty
1	SC-22271	SCREW,M4x0.7X6MM PAN	8
2	5015092R	1200-S SS SIDE PANEL	2
3	GS-23622	GASKET,.375" WIDE FOAM TAPE	1
4	1011653	BONNET TOP COVER 1200-S/UP	1
5	SC-22273	SCREW,M4x0.7X10MM PAN	6
6	55662	PUSH/PULL HANDLE KIT (optional)	1

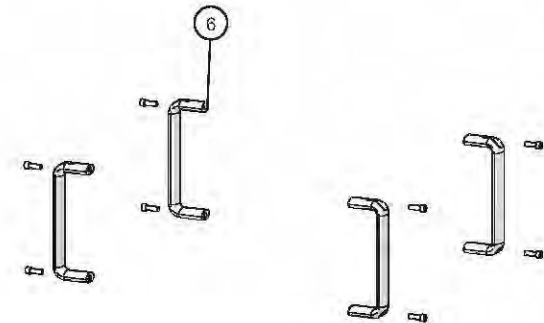

1200-S Exterior Panel Package "B", Pass-Thru

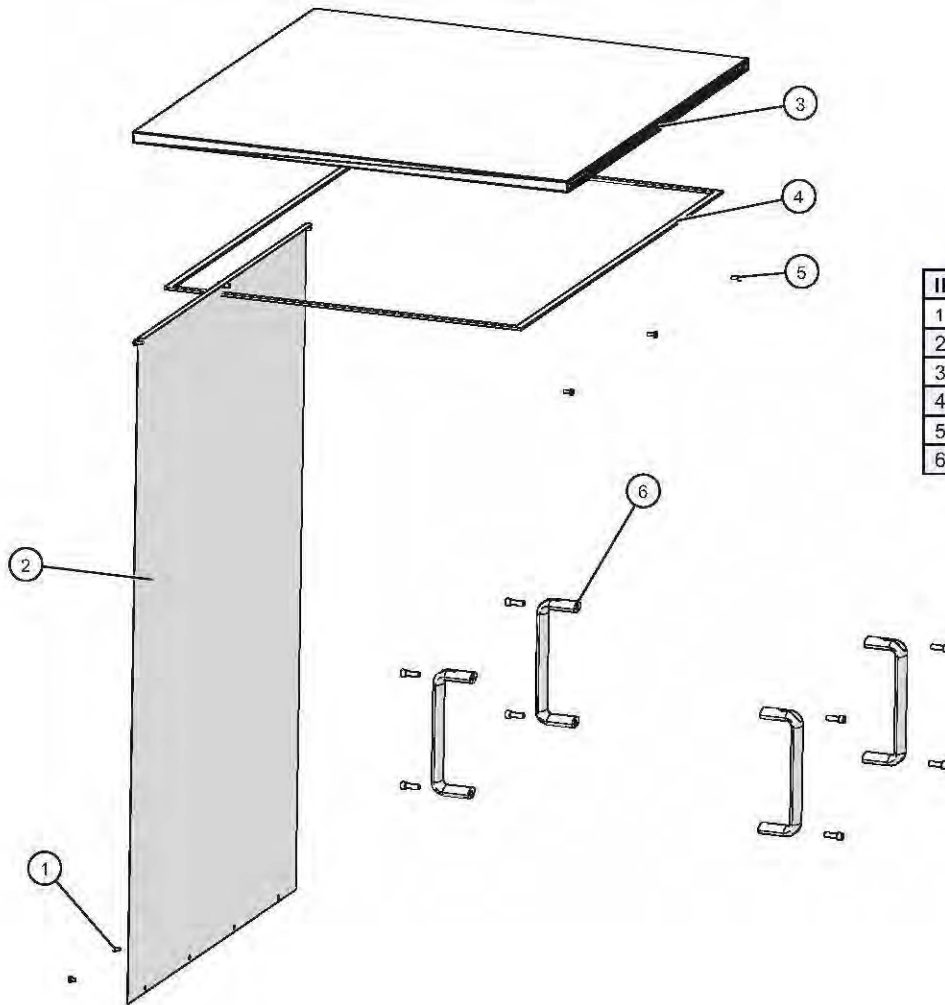

ID	Part No.	Description	Qty
1	SC-22271	SCREW,M4x0.7X6MM PAN	4
2	5015092	1200-S SS SIDE PANEL	1
3	1011653	BONNET TOP COVER 1200-S/UP	1
4	GS-23622	GASKET, FOAM,.125X.375	1
5	SC-22273	SCREW,M4x0.7X10MM PAN	6
6	55662	PUSH/PULL HANDLE KIT (optional)	1

1200-UP Exterior Panel Package "A", Reach-In

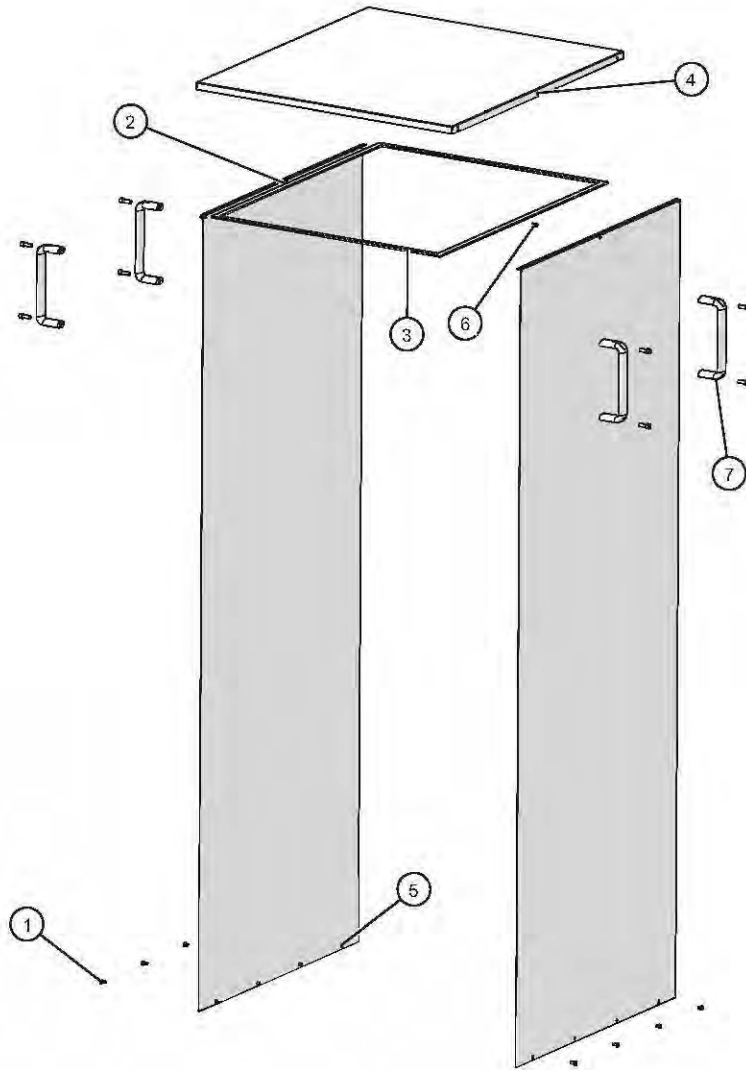

ID	Part No.	Description	Qty
1	SC-2227	SCREW, M4x0.7X	8
2	1011533	SIDE PANEL, 1000/1200-UP	2
3	GS-23622	GASKET, ADHESIVE, .125X 1/2" FOAM TAPE	1
4	1011653	BONNET TOP COVER 1200-S/UP	1
5	SC-2227	SCREW, M4x0.7X	6
6	NU-26866	NUT, HEX INSERT M4	2
7	55662	PUSH/PULL HANDLE KIT (optional)	1

1200-UP Exterior Panel Package "B", Pass-Thru

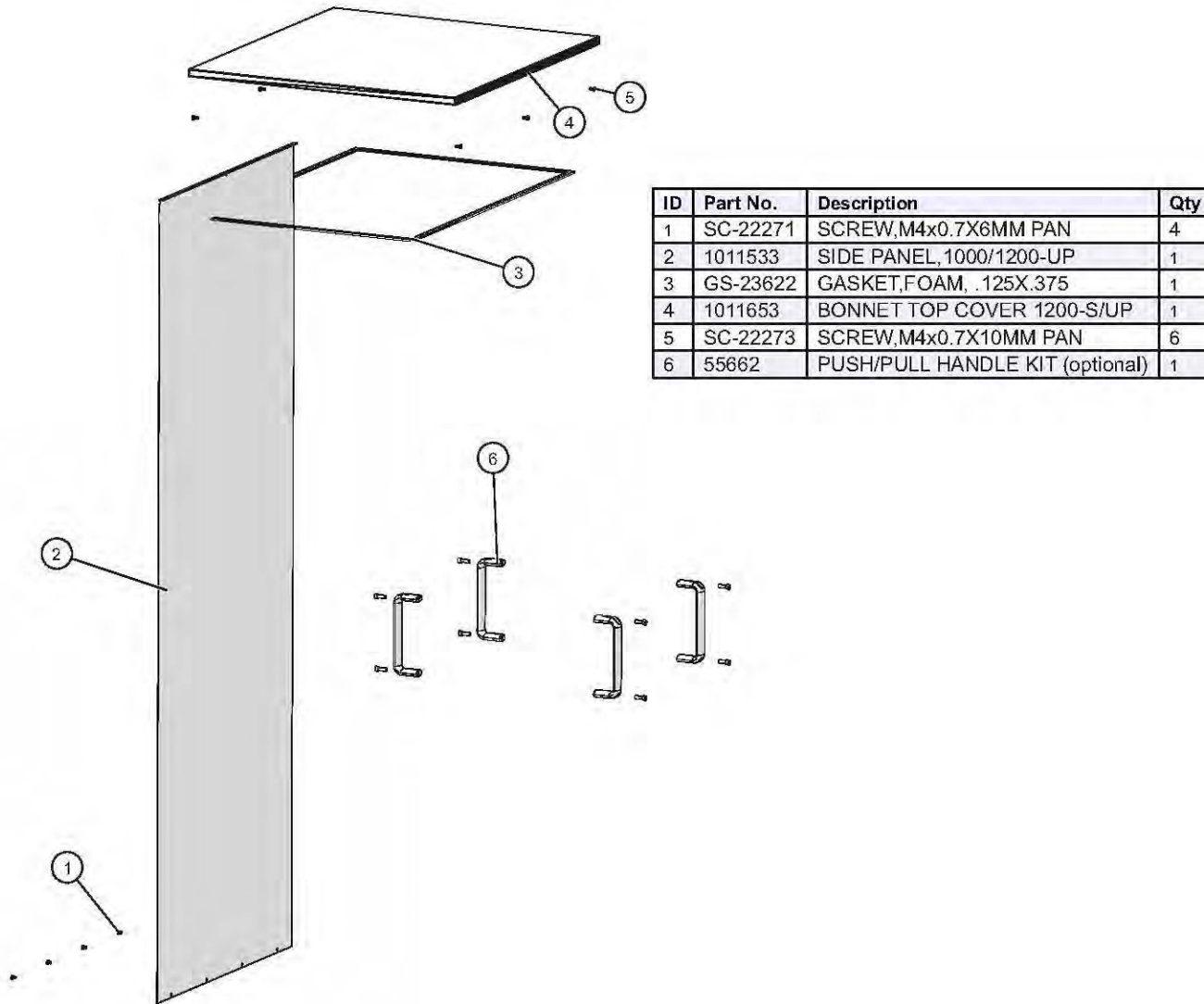

1200-UP Exterior Panel Package "C", Pass-Thru

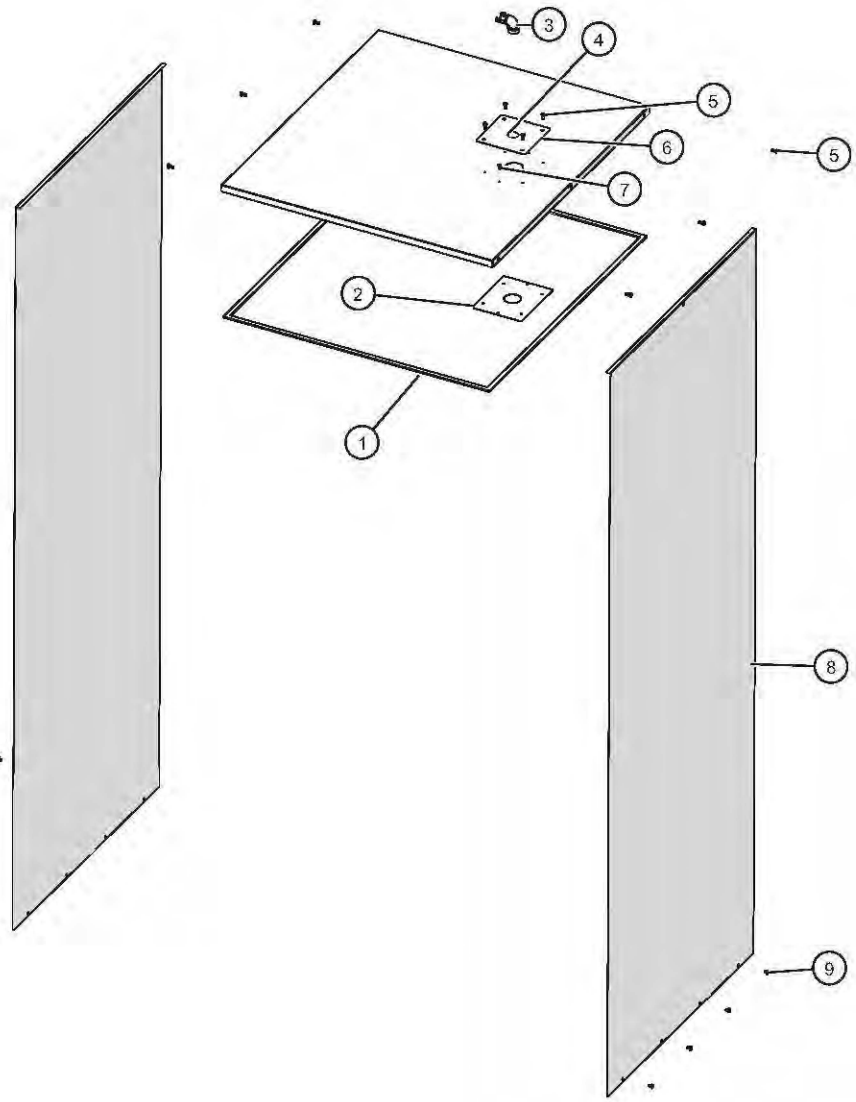

ID	Part No.	Description	Qty
1	GS-23622	GASKET,.375" WIDE FOAM TAPE	1
2	11193	INSIDE BACKER PLATE	1
3	CR-3292	90 DEG CONNECTOR	1
4	1023	GRIP, MTG PLATE	1
5	SC-22273	SCREW,M4x0.7X10MM PAN	10
6	1011970	TOP COVER 1200-S/UP OCB	1
7	RI-2100	RIVET,BLIND,#44,STNLS	2
8	1011533	SIDE PANEL,1000/1200-UP	2
9	SC-22271	SCREW,M4x0.7X6MM PAN	8
10	55662	PUSH/PULL HANDLE KIT (optional)	1

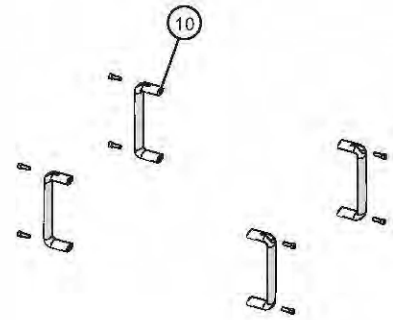

1200-UP Exterior Panel Package "D", Pass-Thru w/Recessed Handles

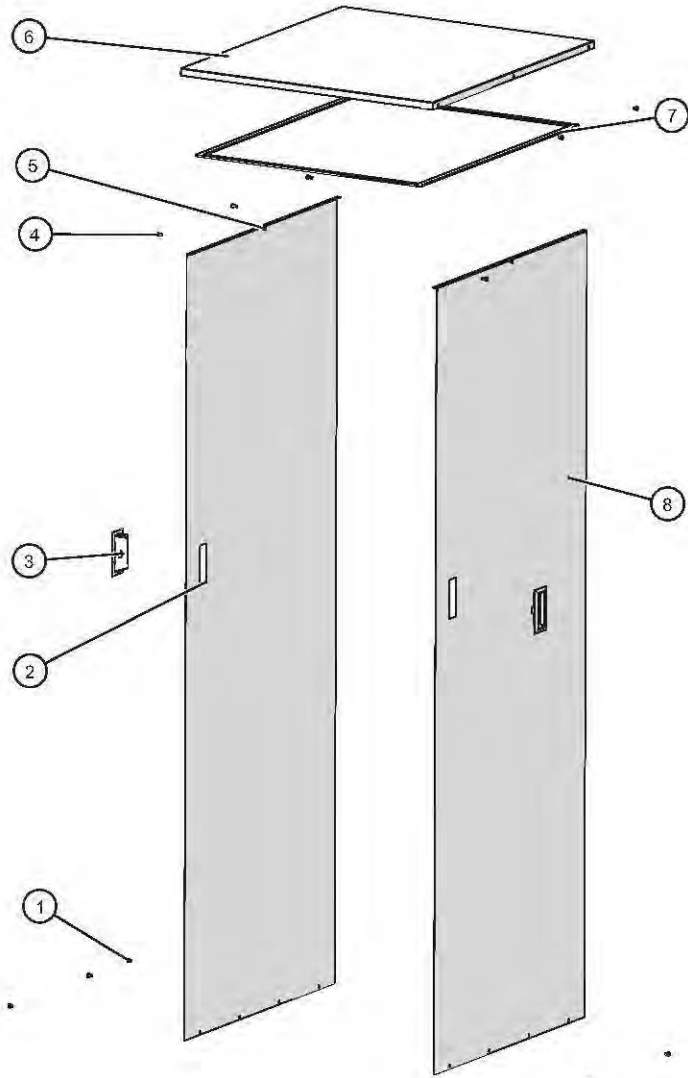

ID	Part No.	Description	Qty
1	SC-22271	SCREW,M4x0.7X6MM PAN	8
2	1034796	1000/1200 LH PANEL,W/HANDLE	1
3	HD-28789	HANDLE, PULL RECESSED, BLACK	2
4	SC-22273	SCREW,M4x0.7X10MM PAN	6
5	NU-26866	NUT, HEX INSERT M4	2
6	1011653	BONNET TOP COVER 1200-S/UP	1
7	GS-23622	GASKET,ADHESIVE,1/2" FOAM	1
8	1034794	1000/1200 RH PANEL,W/HANDLE	1

1200-UP PT Counterweight Kit

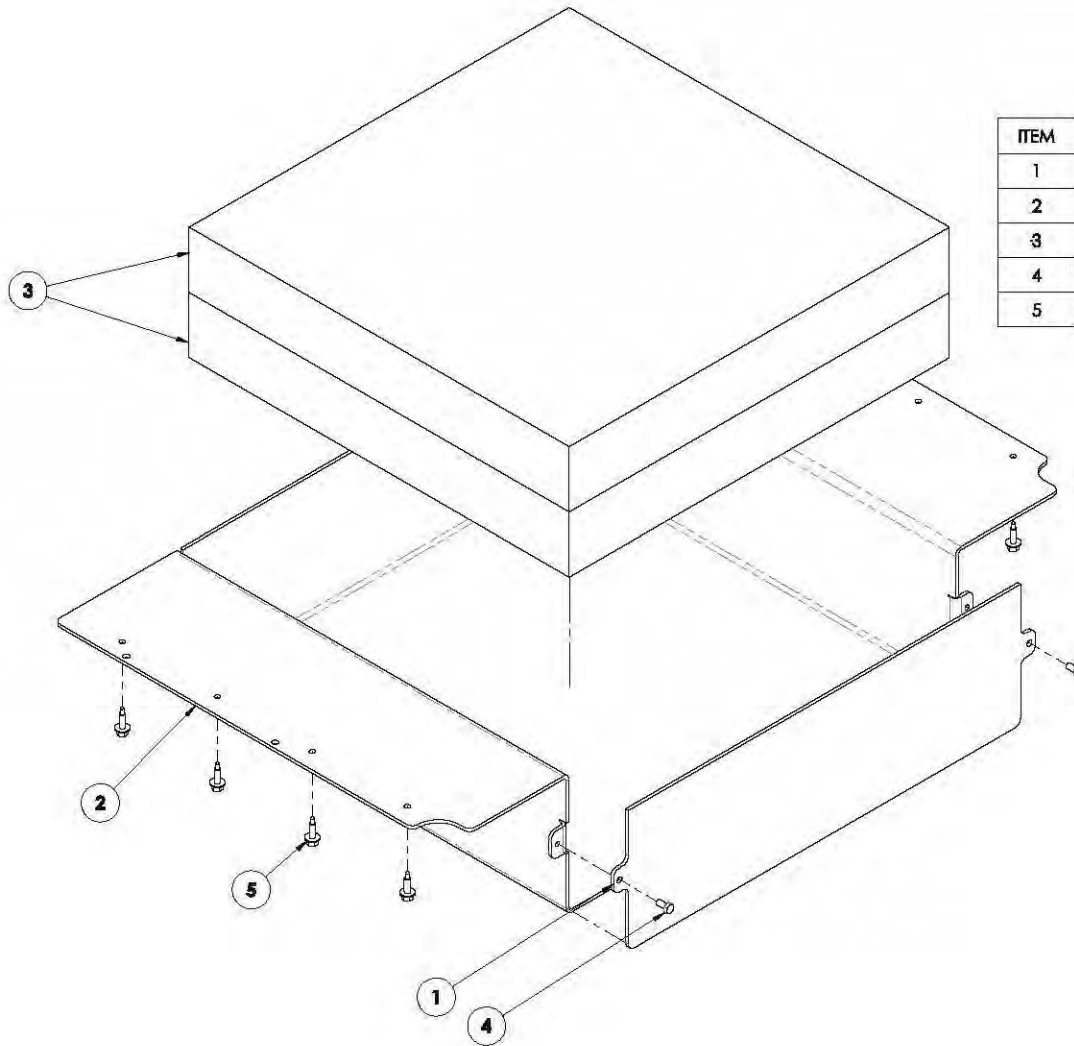

ITEM	PART NUMBER	DESCRIPTION	QTY.
1	1034004	COUNTERWEIGHT, COVER	1
2	1034005	COUNTERWEIGHT, MOUNT	1
3	1034006	COUNTERWEIGHT, 16 X 16 SLAB	2
4	SC-23737	M5X10, HEX, HD CAP #18-8, NO SLOT	2
5	SC-27384	SCREW-#10-16 SELF DRILLING	8

1200-S/-UP Bumper Assembly

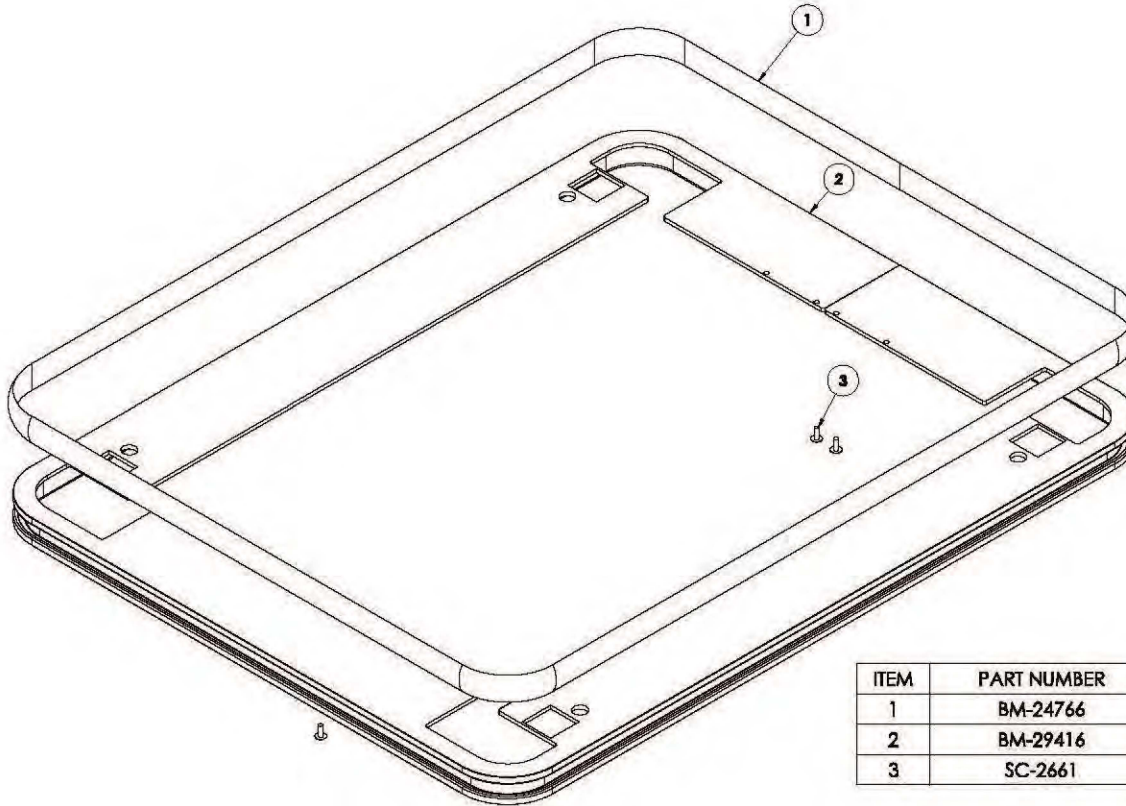

ITEM	PART NUMBER	DESCRIPTION	QTY
1	BM-24766	BUMPER, PERIMETER, RUBBER [lin ft]	9.8'
2	BM-29416	1200 WARMER SERIES BUMPER	1
3	SC-2661	SCREW, 10-32 X1/2, NF PHIL TRUSS M/S, 18-8 SS	3

Security Panel (optional)

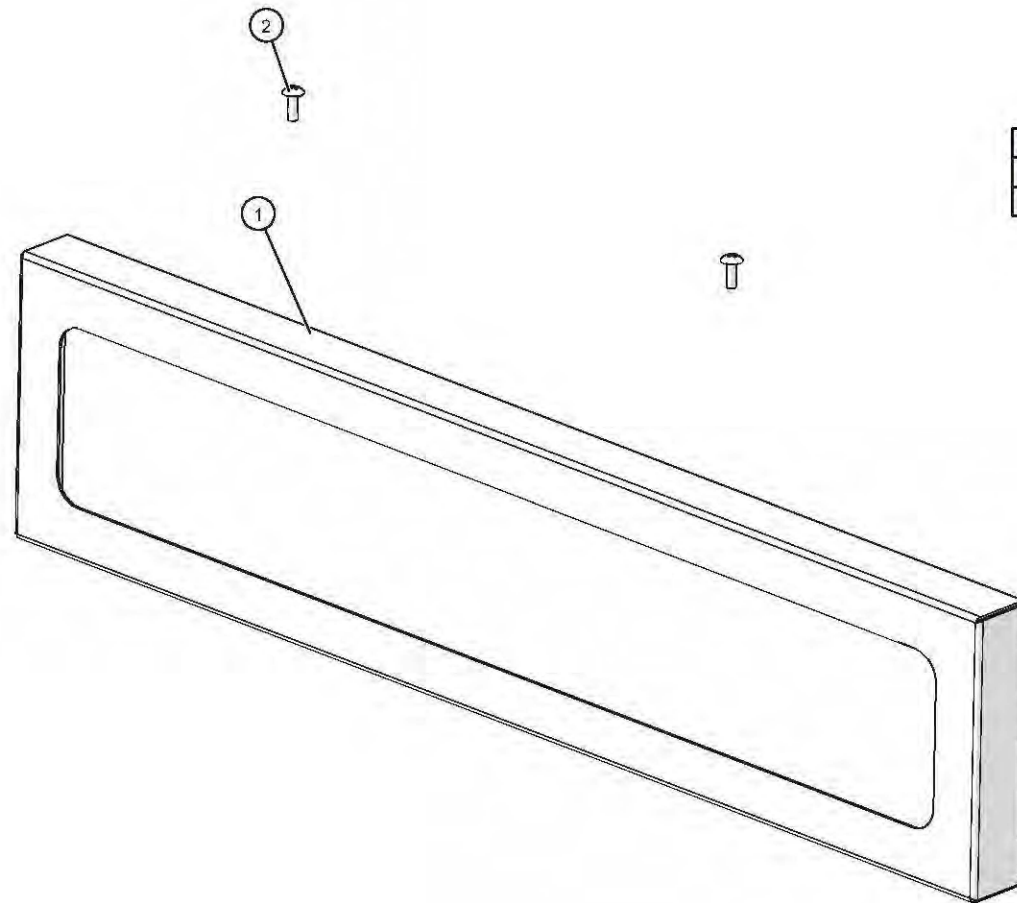

ID	Part No.	Description	Qty
1	1012485	750 SECURITY PANEL FRAME	1
2	SC-2425	8-32 x 1/2" PHIL SCREW	3

1200-S Core Assembly, Reach-In, Simple

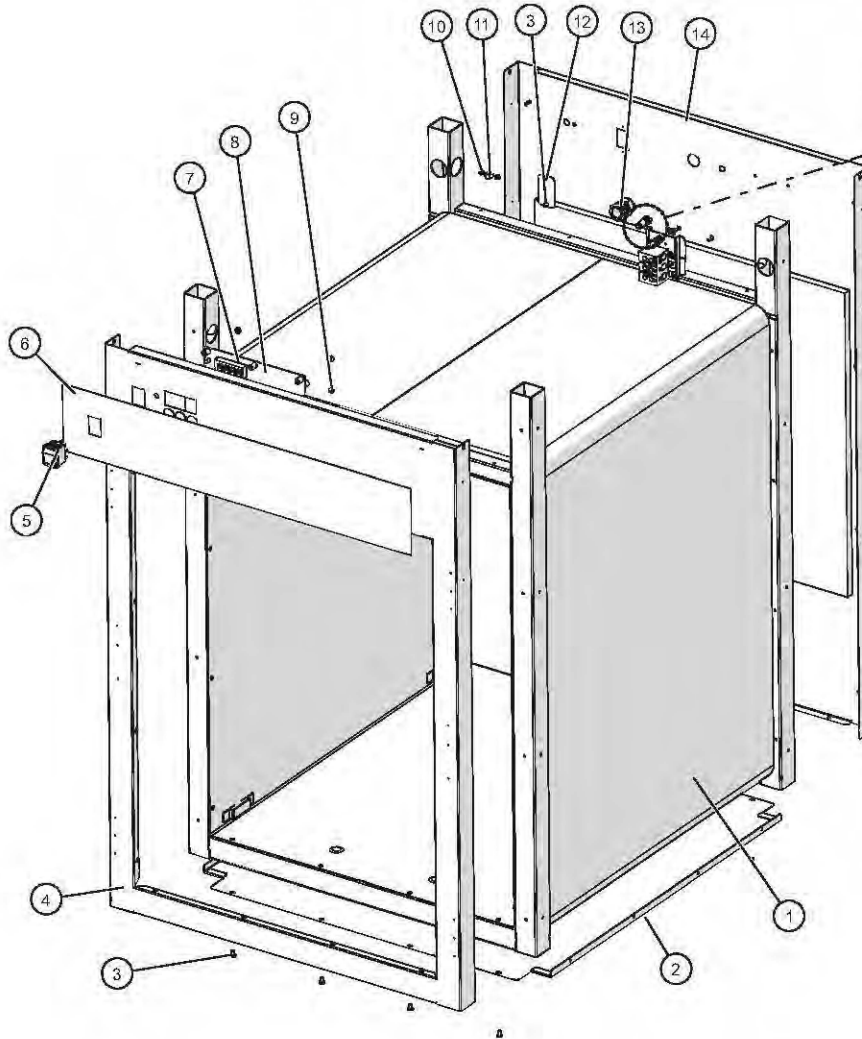

ID	Part No.	Description	Qty
1	5014554	CAVITY PKG 'A',REACH-IN	1
2	1011650	BOTTOM PANEL,1200-S/UP	1
3	SC-22271	M4 X 6MM PH PAN HD M/S .7	12
4	5034537	TRIM ASSY,SIMPLE,FRONT	1
5	SW-38665	SWITCH,ROCKER,DPST,20A,125V,	1
6	PE-47894	OVERLAY, DISPLAY, ELAN '10	1
7	WS-23148	WASHER, 6-32, FLAT, NYL	4
8	5034317	CONTROL ASSY,SIMPLE,SINGLES	1
9	NU-2361	NUT, 6-32 HEX, S/S	4
10	PG-28439	PLUG, DOME, .187" HOLE	2
11	PG-25574	3/8" HOLE PLUG	1
12	1011697	BREAKER SWITCH CUTOUT COVER	1
13	BU-3964	BUSHING, STRAIGHT, STRAIN RELIEF	1
14	5034536	PANEL ASSY, REACH-IN, BACK	1
15	SC-22924	HHCS, M6 X 20, W/NO MARKING	1
16	WS-22297	WASHER, FLAT	2
17	WS-22302	WASHER, SPLIT LOCK	2
18	NU-22770	NUT, THREADED INSERT, M6	1
19	SN-47162	SENSOR, 1000 OHM, 40" WIRE,	1
20	BK-29805	BLOCK, SENSOR, ELEC. CONTROL	1
21	1493	GUARD SENSOR,W/MW	1

1200-S Core Assembly, Pass-Thru, Simple

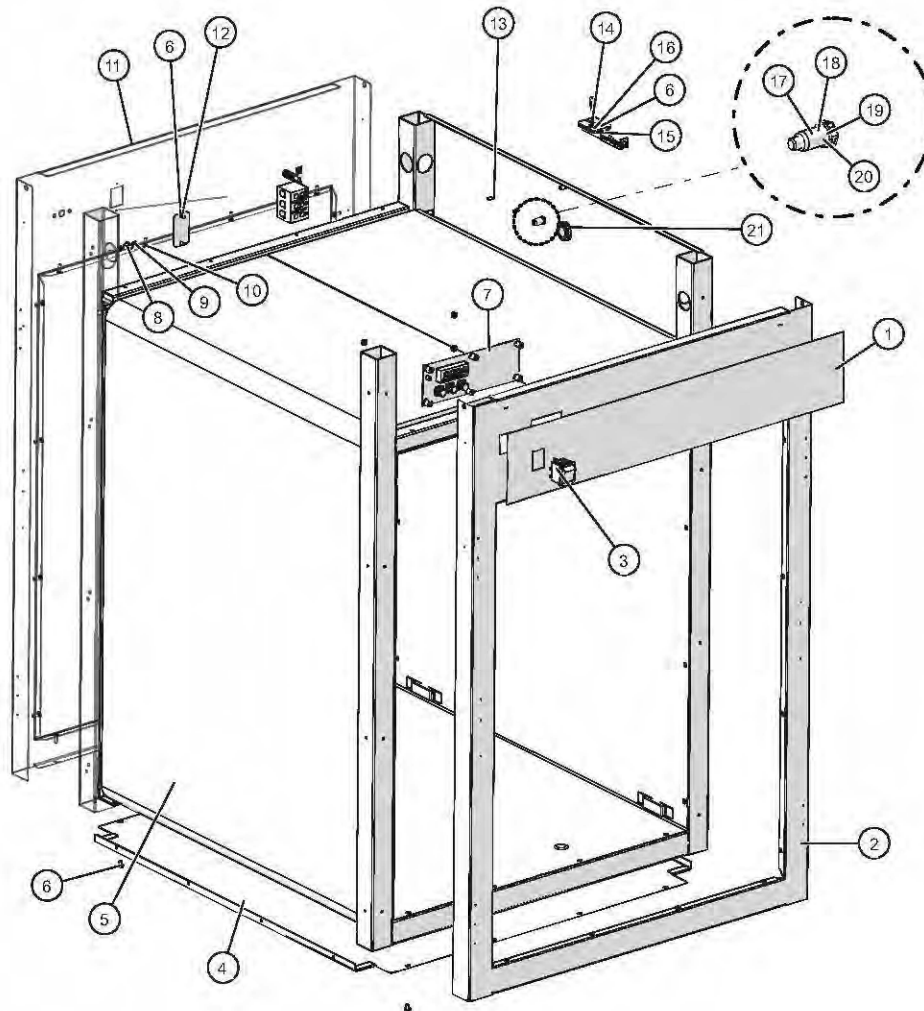

ID	Part No.	Description	Qty
1	PE-47894	OVERLAY, DISPLAY, ELAN '10	1
2	5034537	TRIM ASSY,SIMPLE,FRONT	1
3	SW-38665	SWITCH,ROCKER,DPST,20A,125V,	1
4	1011650	BOTTOM PANEL,1200-S/UP	1
5	5014555	CAVITY PKG "B",PASS-THRU	1
6	SC-22271	SCREW,M4x0.7X6MM PAN	12
7	5034317	CONTROL ASSY,SIMPLE,SINGLES	1
8	PG-25574	3/8" HOLE PLUG	1
9	PG-28439	PLUG, DOME,.187" HOLE	2
10	RI-27108	RIVET, SEALED, 0.125" x 0.45"	32
11	5034542	TRIM ASSY,PASS-THRU,BACK	1
12	1011697	BREAKER SWITCH CUTOUT COVER	1
13	RI-38125	RIVET,SEALED,.125", GRIP .039-.118	2
14	SN-47162	SENSOR, 1000 OHM, 40" WIRE,	1
15	1493	GUARD SENSOR,W/MW	1
16	BK-29605	BLOCK, SENSOR, ELEC. CONTROL	1
17	NU-22770	NUT, THREADED INSERT, M6	1
18	WS-22297	WASHER, FLAT	2
19	SC-22924	HHCS, M6 X 20, W/NO MARKING	1
20	WS-22302	WASHER, SPLIT LOCK	2
21	BU-3964	BUSHING,STRAIGHT,STRAIN RELIEF	1

1200-S Core Assembly, Reach-In, Simple, 2000W

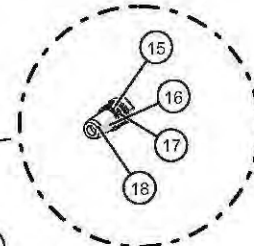
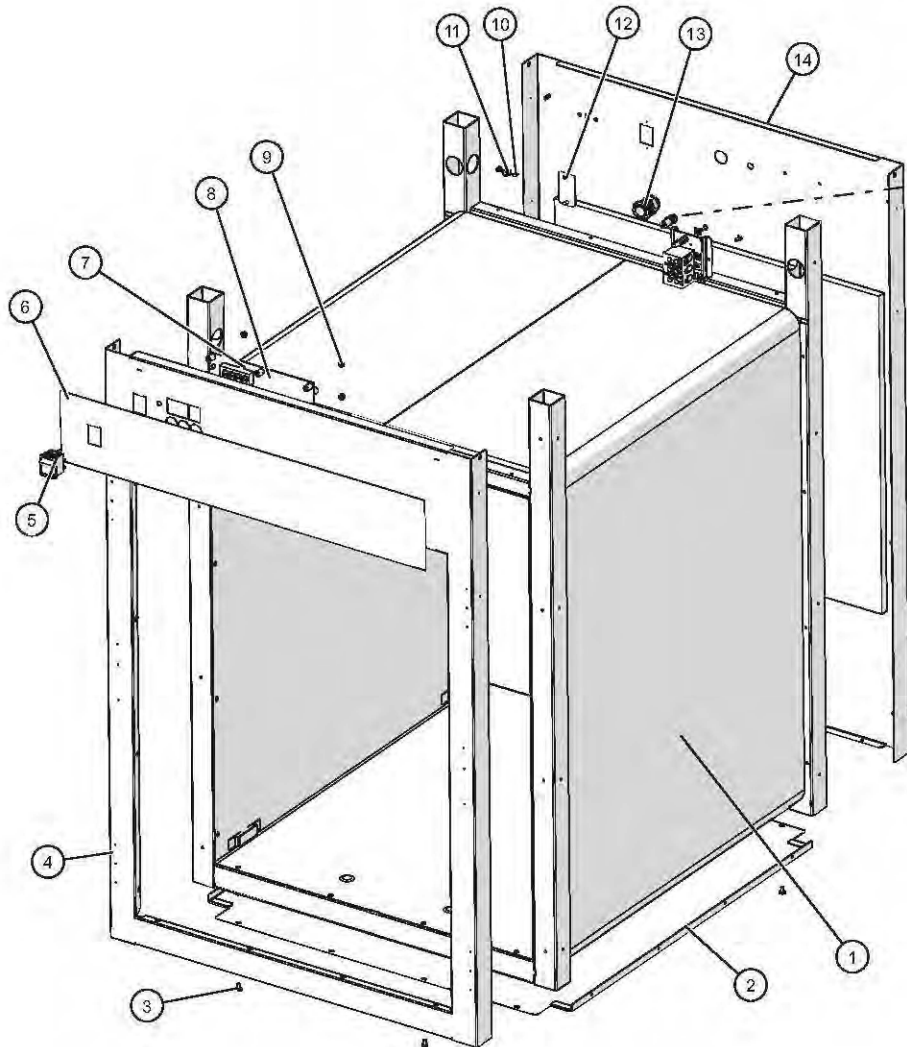

ID	Part No.	Description	Qty
1	5014556	CAVITY PKG 'C',REACH-IN,2000W	1
2	1011650	BOTTOM PANEL,1200-S/UP	1
3	SC-22271	M4 X 6MM PH PAN HD M/S .7	10
4	5034537	TRIM ASSY,SIMPLE,FRONT	1
5	SW-38665	SWITCH,ROCKER,DPST,20A,125V,	1
6	PE-47894	OVERLAY, DISPLAY, ELAN '10	1
7	WS-23148	WASHER, 6-32, FLAT, NYL	4
8	5034317	CONTROL ASSY,SIMPLE,SINGLES	1
9	NU-2361	NUT, 6-32 HEX, S/S	4
10	PG-28439	PLUG, DOME, .187" HOLE	2
11	PG-25574	3/8" HOLE PLUG	1
12	1011697	BREAKER SWITCH CUTOFF COVER	1
13	BU-3964	BUSHING,STRAIGHT,STRAIN RELIEF	1
14	5034536	PANEL ASSY,REACH-IN,BACK	1
15	SC-22924	HHCS, M6 X 20, W/NO MARKING	2
16	WS-22297	WASHER, FLAT	4
17	WS-22302	WASHER, SPLIT LOCK	4
18	NU-22770	NUT, THREADED INSERT, M6	2
19	SN-47162	SENSOR, 1000 OHM, 40" WIRE,	1
20	BK-29605	BLOCK, SENSOR, ELEC. CONTROL	1
21	1493	GUARD SENSOR,W/MW	1

1200-S Core Assembly, Reach-In, Deluxe w/Timer

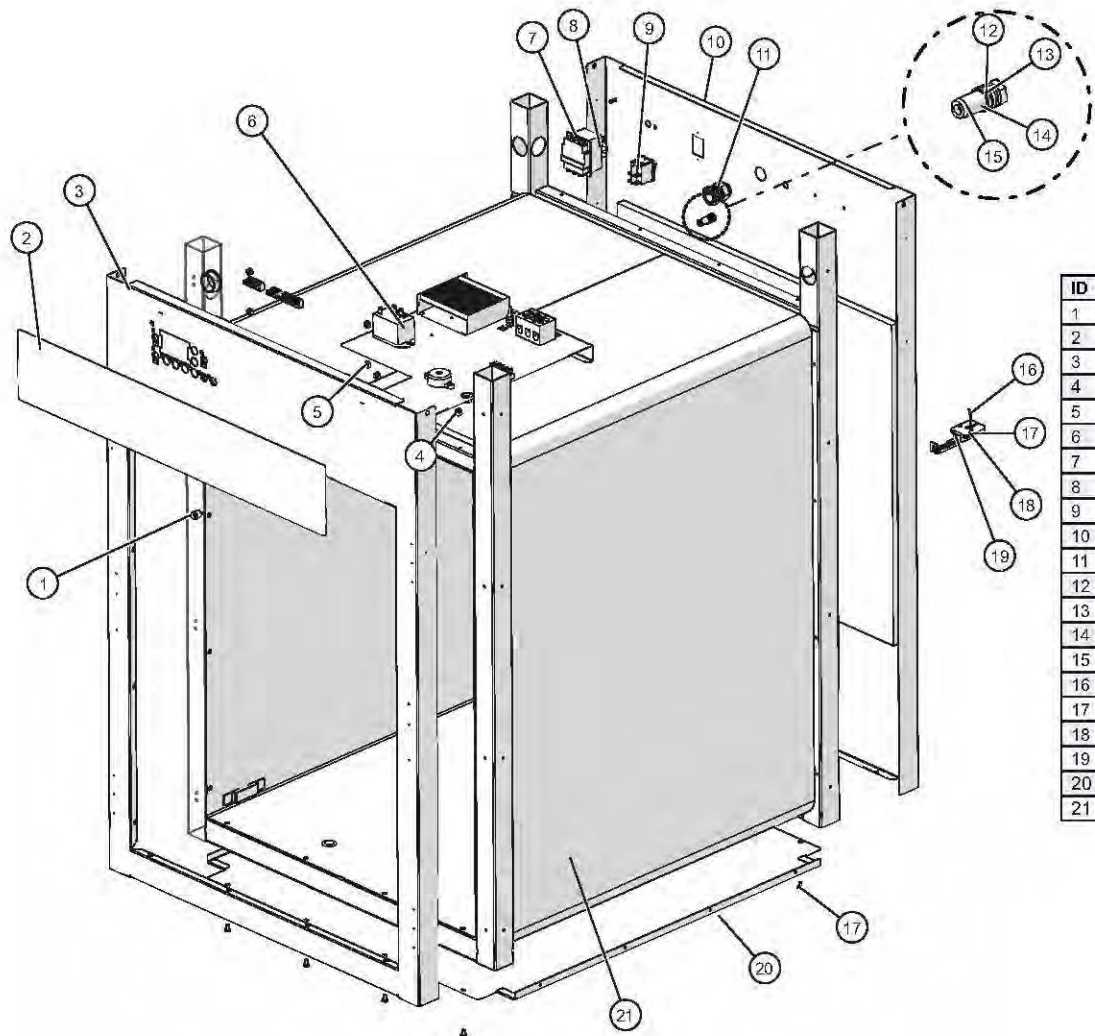

ID	Part No.	Description	Qty
1	5034314	SWITCH, REED, ASSEMBLY	1
2	PE-28833	1200-S, ELEC, W/TIMER OVERLAY	1
3	5034541	TRIM, W/TIMER, DX, FRONT	1
4	NU-2296	NUT, HEX #8-32	2
5	NU-26526	NUT, #8-32 UNC KEPS ZP	4
6	5034305	WARMER SERIES, DELUXE	1
7	TT-33476	THERMOSTAT, 300F HI-LIMIT	1
8	1003936	HI-LIMIT PROTECTION COVER	1
9	SW-38665	SWITCH, ROCKER, DPST, 20A, 125V,	1
10	5034536	PANEL ASSY, REACH-IN, BACK	1
11	BU-3964	BUSHING, STRAIGHT, STRAIN RELIEF	1
12	WS-22302	WASHER, SPLIT LOCK, M6, 18-8 SST	2
13	SC-22924	HHCS, M6 X 20, W/NO MARKING	1
14	WS-22297	WASHER, FLAT, M6, 18-8 SST	2
15	NU-22770	NUT, THREADED INSERT, M6	1
16	SN-38110	SENSOR, 100 OHM, 110" WIRE,	1
17	SC-22271	M4 X 6MM PH PAN HD M/S .7	12
18	BK-29605	BLOCK, SENSOR, ELEC. CONTROL	1
19	1493	GUARD SENSOR, W/MW	1
20	1011650	BOTTOM PANEL, 1200-S/UP	1
21	5014554	CAVITY PKG 'A', REACH-IN	1

1200-UP Core Assembly, Reach-In, Simple

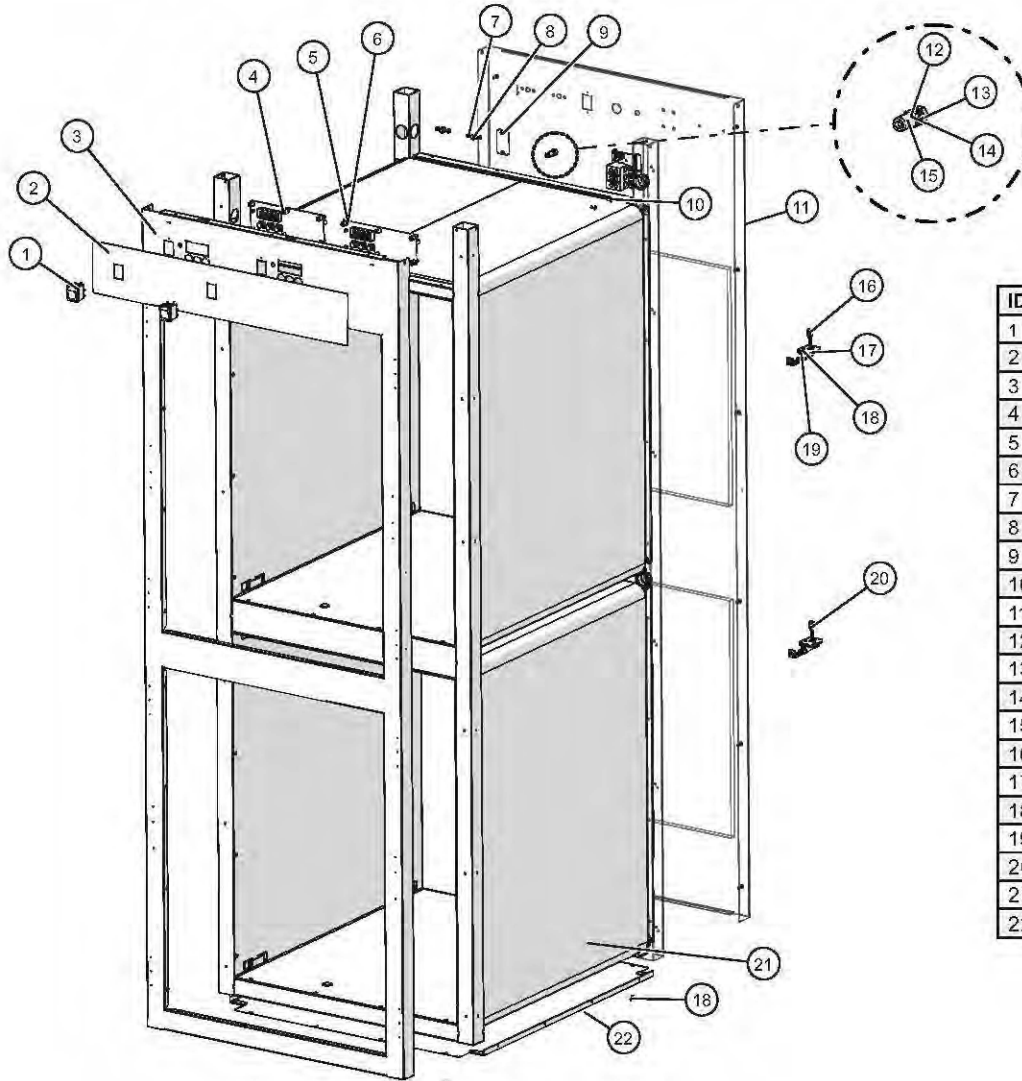

ID	Part No.	Description	Qty
1	SW-38665	SWITCH,ROCKER,DPST,20A,125V,	2
2	SC-22271	OVERLAY, DISPLAY, ELAN '10	1
3	5034624	TRIM,FRONT,OVERLAY ASSY,SIMPLE	1
4	5012553	CONTROL ASSY,SIMPLE,DOUBLES,	1
5	NU-2361	NUT, 6-32 HEX, S/S	8
6	WS-23148	WASHER, 6-32, FLAT, NYL	8
7	PG-28439	PLUG, DOME,.187" HOLE	4
8	PG-25574	3/8" HOLE PLUG	2
9	1011697	BREAKER SWITCH CUTOUT COVER	1
10	RI-38125	RIVET,SEALED,.125"	2
11	5034644	PANEL ASSY,REACH-IN,BACK	1
12	WS-22297	WASHER, FLAT, M6, 18-8 SST	2
13	SC-22924	HHCS, M6 X 20, W/NO MARKING	1
14	WS-22302	WASHER, SPLIT LOCK, M6, 18-8 SST	2
15	NU-22770	NUT, THREADED INSERT, M6	1
16	SN-47162	SENSOR, 1000 OHM, 40" WIRE,	1
17	BK-29605	BLOCK, SENSOR, ELEC. CONTROL	2
18	SC-22271	SCREW, PAN HEAD M4 X 7MM	14
19	1493	GUARD SENSOR,W/MW	2
20	SN-38111	SENSOR, 1000 OHM, 110" WIRE,	1
21	5014417	CAVITY PKG,REACH-IN,4000W	1
22	1011650	BOTTOM PANEL,1200-S/UP	1

1200-UP Core Assembly, Reach-In, 2000W Simple

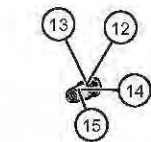
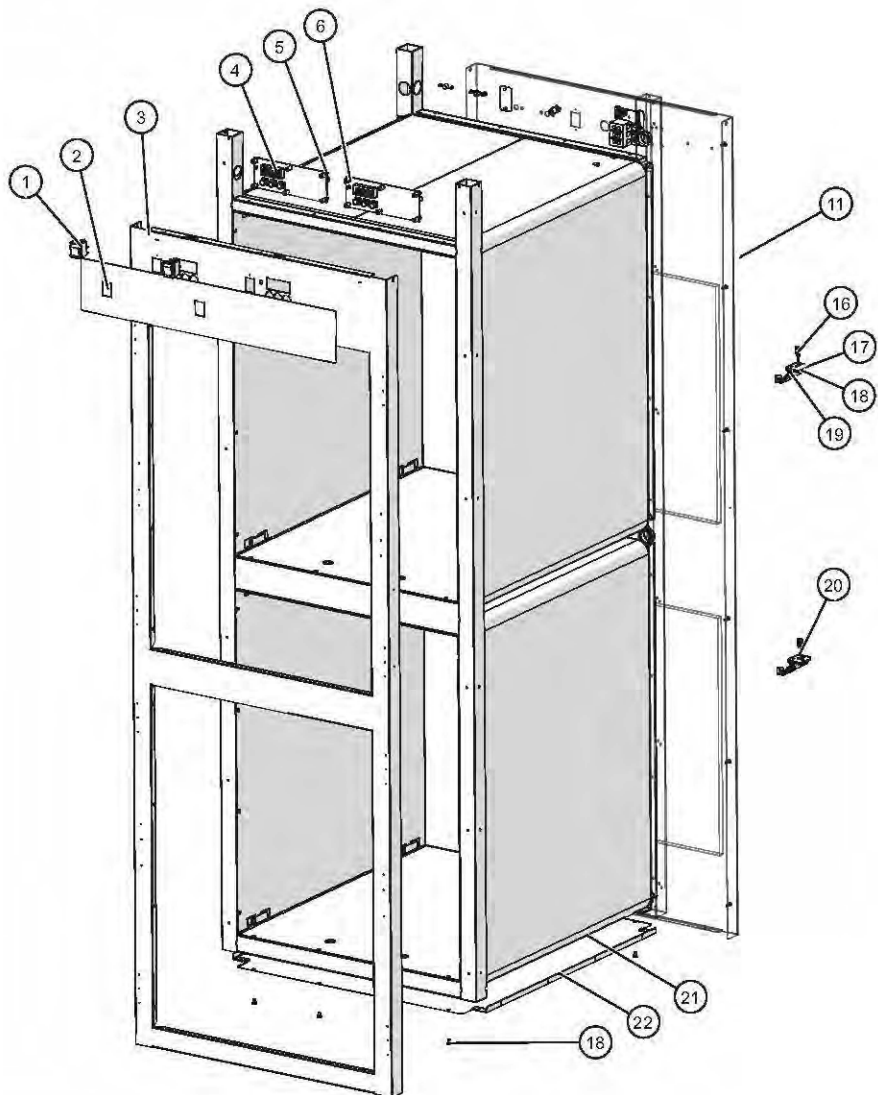

ID	Part No.	Description	Qty
1	SW-38665	SWITCH,ROCKER,DPST,20A,125V,	2
2	SC-22271	OVERLAY, DISPLAY, ELAN '10	1
3	5034624	TRIM,FRONT,OVERLAY ASSY,SIMPLE	1
4	5012553	CONTROL ASSY,SIMPLE,DOUBLES,	1
5	NU-2361	NUT, 6-32 HEX, S/S	8
6	WS-23148	WASHER, 6-32, FLAT, NYL	8
11	5034644	PANEL ASSY,REACH-IN,BACK	1
12	WS-22297	WASHER, FLAT, M6, 18-8 SST	4
13	SC-22924	HHCS, M6 X 20, W/NO MARKING	2
14	WS-22302	WASHER, SPLIT LOCK, M6, 18-8 SST	4
15	NU-22770	NUT, THREADED INSERT, M6	2
16	SN-47162	SENSOR, 1000 OHM, 40" WIRE,	1
17	BK-29605	BLOCK, SENSOR, ELEC. CONTROL	2
18	SC-22271	SCREW, PAN HEAD M4 X 7MM	12
19	1493	GUARD SENSOR,W/MW	2
20	SN-38111	SENSOR, 1000 OHM, 110" WIRE,	1
21	5014415	CAVITY PKG,REACH-IN,2000W	1
22	1011650	BOTTOM PANEL,1200-S/UP	1

1200-UP Core Assembly, Pass-Thru, Simple

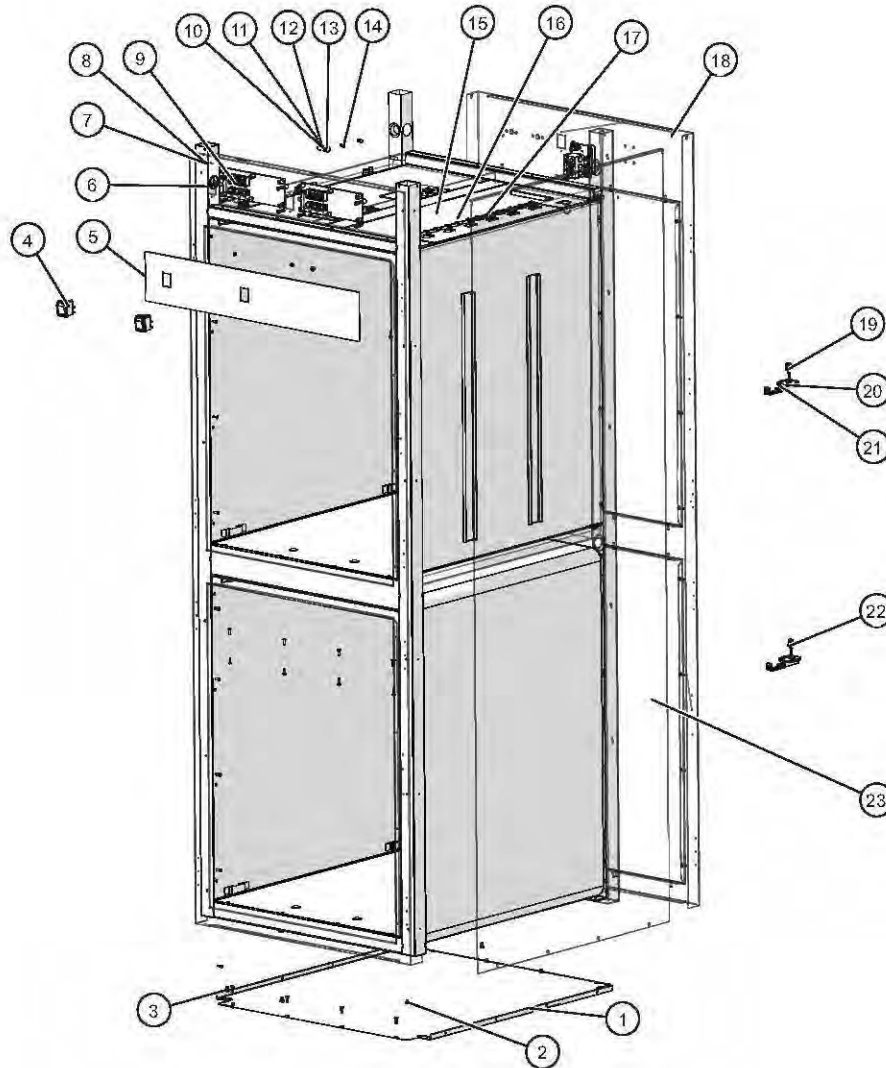

ID	Part No.	Description	Qty
1	1011650	BOTTOM PANEL,1200-S/UP	1
2	RI-27108	RIVET, SEALED	64
3	SC-22271	SCREW, PAN HEAD M4 X 7MM	12
4	SW-38665	SWITCH,ROCKER,DPST,20A,125V,	2
5	PE-47895	OVERLAY, DISPLAY, ELAN '10	1
6	5034624	TRIM,FRONT,OVERLAY ASSY,SIMPLE	1
7	WS-23148	WASHER, 6-32, FLAT, NYL	8
8	NU-2361	NUT, 6-32 HEX, S/S	8
9	5012553	CONTROL ASSY,SIMPLE,DOUBLES,	1
10	WS-22302	WASHER, SPLIT LOCK, M6, 18-8 SST	2
11	WS-22297	WASHER, FLAT, M6, 18-8 SST	2
12	NU-22770	NUT, THREADED INSERT, M6	1
13	SC-22924	HHCS, M6 X 20, W/NO MARKING	1
14	RI-38125	RIVET,SEALED,.125"	2
15	PG-25574	3/8" HOLE PLUG	2
16	PG-28439	PLUG, DOME,.187" HOLE	4
17	1011697	BREAKER SWITCH CUTOUT COVER	1
18	5034600	TRIM,REAR ASSY,PASS-THRU	1
19	SN-47162	SENSOR, 1000 OHM, 40" WIRE,	1
20	BK-29605	BLOCK, SENSOR, ELEC. CONTROL	2
21	1493	GUARD SENSOR,W/MW	2
22	SN-38111	SENSOR, 1000 OHM, 110" WIRE,	1
23	1038311	SIDE PANEL 1000/1200 SERIES	1

1200-UP Core Assembly, Pass-Thru, 2000W Simple

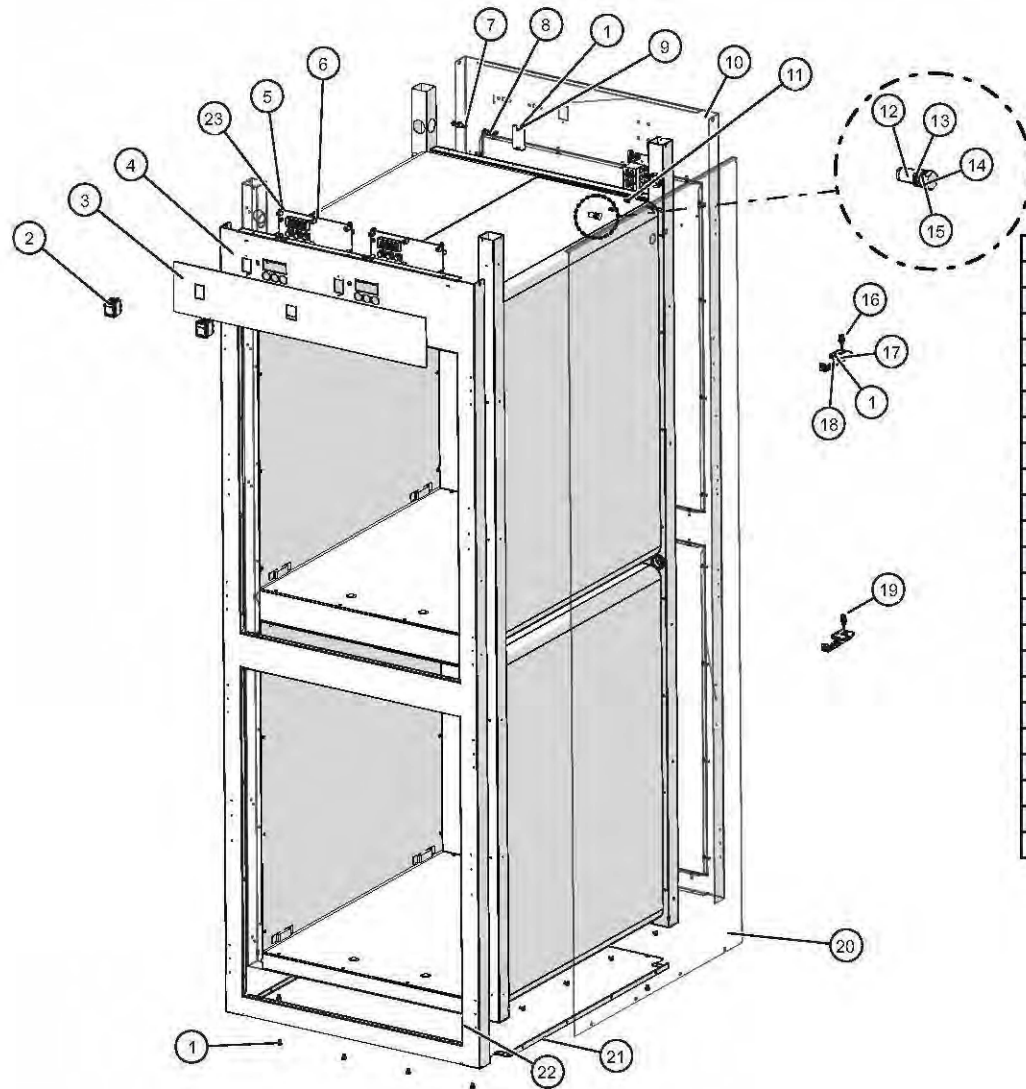

ID	Part No.	Description	Qty
1	SC-22271	SCREW, PAN HEAD M4 X 7MM	12
2	SW-38665	SWITCH,ROCKER,DPST,20A,125V,	2
3	PE-47895	OVERLAY, DISPLAY, ELAN '10	1
4	5034624	TRIM,FRONT,OVERLAY ASSY,SIMPLE	1
5	NU-2361	NUT, 6-32 HEX, S/S	8
6	5012553	CONTROL ASSY,SIMPLE,DOUBLES,	1
7	PG-28439	PLUG, DOME, .187" HOLE	4
8	PG-25574	3/8" HOLE PLUG	2
9	1011697	BREAKER SWITCH CUTOUT COVER	1
10	5034600	TRIM,REAR ASSY,PASS-THRU	1
11	RI-38125	RIVET,SEALED,.125"	2
12	NU-22770	NUT, THREADED INSERT, M6	1
13	WS-22297	WASHER, FLAT, M6, 18-8 SST	2
14	SC-22924	HHCS, M6 X 20, W/NO MARKING	1
15	WS-22302	WASHER, SPLIT LOCK, M6, 18-8 SST	2
16	SN-47162	SENSOR, 1000 OHM, 40" WIRE,	1
17	BK-29605	BLOCK, SENSOR, ELEC. CONTROL	2
18	1493	GUARD SENSOR,W/MW	2
19	SN-38111	SENSOR, 1000 OHM, 110" WIRE,	1
20	1038311	SIDE PANEL 1000/1200 SERIES	1
21	1011650	BOTTOM PANEL,1200-S/UP	1
22	RI-27108	RIVET, SEALED	64
23	WS-23148	WASHER, 6-32, FLAT, NYL	8

1200-UP Core Assembly, Reach-In, 2000W Deluxe

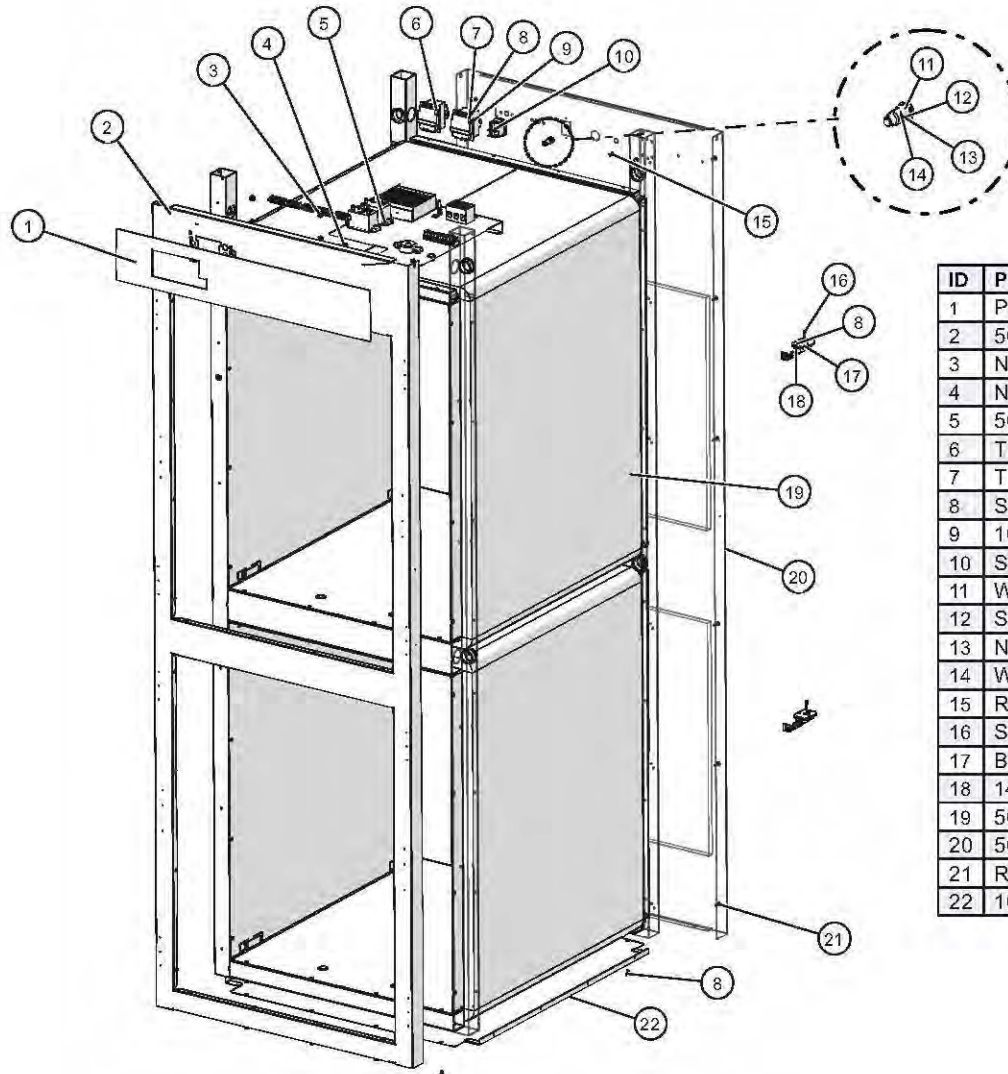

ID	Part No.	Description	Qty
1	PE-27855	1200-UP, ELEC, OVERLAY	1
2	5034626	TRIM,FRONT,DX,OVERLAY ASSY	1
3	NU-26526	NUT, #8-32 UNC KEPS ZP	4
4	NU-2296	NUT, HEX #8-32	2
5	5034606	WARMER SERIES DELUXE DOUBLES,	1
6	TT-34600	THERMOSTAT, 300F HI-LIMIT, MANUAL RESET	1
7	TT-33476	THERMOSTAT, 300F HI-LIMIT,DPST 16A	1
8	SC-22271	SCREW, PAN HEAD M4 X 7MM	16
9	1003936	HI-LIMIT PROTECTION COVER	2
10	SW-38665	SWITCH,ROCKER,DPST,20A,125V,	1
11	WS-22297	WASHER, FLAT, M6, 18-8 SST	2
12	SC-22924	HHCS, M6 X 20, W/NO MARKING	1
13	NU-22770	NUT, THREADED INSERT, M6	1
14	WS-22302	WASHER, SPLIT LOCK, M6, 18-8 SST	2
15	RI-38125	RIVET,SEALED,.125"	2
16	SN-38110	SENSOR, 100 OHM, 110" WIRE,	2
17	BK-29605	BLOCK, SENSOR, ELEC. CONTROL	2
18	1493	GUARD SENSOR,W/MW	2
19	5014415	CAVITY PKG,REACH-IN,2000W	1
20	5034644	PANEL ASSY,REACH-IN,BACK	1
21	RI-27108	RIVET, SEALED, 0.125" X 0.45"	44
22	1011650	BOTTOM PANEL,1200-S/UP	1

1200-UP Core Assembly, Reach-In, Deluxe

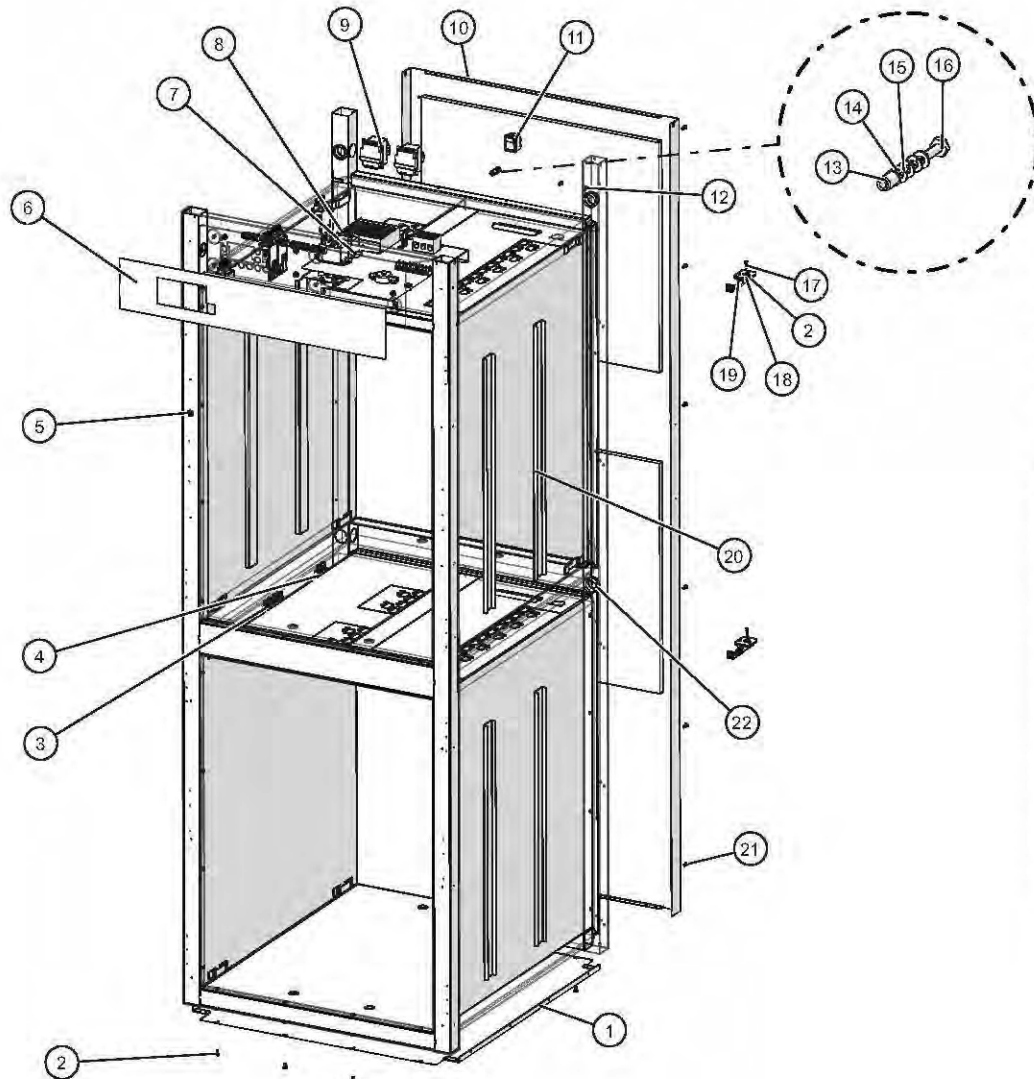

ID	Part No.	Description	Qty
1	1011650	BOTTOM PANEL,1200-S/UP	1
2	SC-22271	SCREW, M4X0.7X6MM PAN	16
3	BU-3106	BUSHING, FEMALE CERAMIC	16
4	BU-3105	BUSHING, MALE CERAMIC	16
5	BU-3419	3/8" BLACK HOLE BUSHING	2
6	PE-27855	1200-UP, ELEC, OVERLAY	1
7	5034606	ELEC CHASSIS, DELUXE DOUBLES	1
8	5034314	SWITCH, REED, ASSEMBLY	2
9	5034668	MOUNTING, CONTROL, ASSY, DX	1
10	5034644	PANEL ASSY, REACH-IN, BACK	1
11	SW-38665	SWITCH, ROCKER, DPST, 20A, 125V,	1
12	RI-38125	RIVET, SEALED, .125"	2
13	NU-22770	NUT, THREADED INSERT, M6	1
14	WS-22297	WASHER, FLAT, M6, 18-8 SST	2
15	WS-22302	WASHER, SPLIT LOCK, M6, 18-8 SST	2
16	SC-22924	HHCS, M6 X 20, W/NO MARKING	1
17	SN-38110	SENSOR, 100 OHM, 110" WIRE,	2
18	BK-29605	BLOCK, SENSOR, ELEC. CONTROL	2
19	1493	GUARD SENSOR, W/MW	2
20	5012671	1200-S/UP 2K CABLE ASSB	2
21	RI-27108	RIVET, SEALED, 0.125" X 0.45"	12
22	BU-3378	1 1/8" SNAP BUSHING	6

1200-UP Core Assembly, Pass-Thru, Deluxe

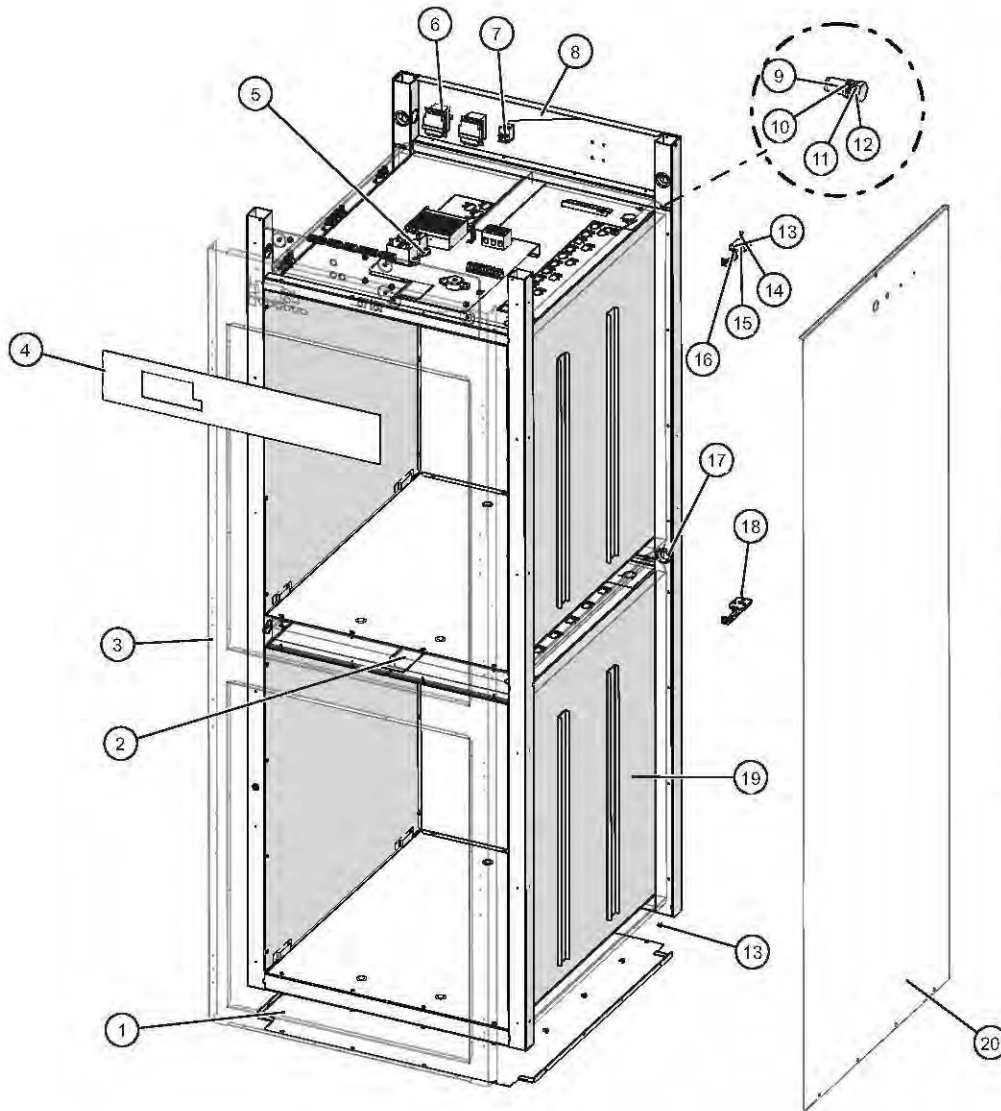

ID	Part No.	Description	Qty
1	1011650	BOTTOM PANEL, 1200-S/UP	1
2	5034314	SWITCH, REED, ASSEMBLY	4
3	5012660	1200-UP ELEC FRONT TRIM	1
4	PE-27855	1200-UP, ELEC, OVERLAY	1
5	5034606	CHASSIS, DELUXE DOUBLES	1
6	5034668	MOUNTING, CONTROL, ASSY, DX	1
7	SW-38665	SWITCH, ROCKER, DPST, 20A, 125V,	1
8	5034600	TRIM, REAR ASSY, PASS-THRU	1
9	NU-22770	NUT, THREADED INSERT, M6	1
10	WS-22297	WASHER, FLAT	2
11	WS-22302	WASHER, SPLIT LOCK	2
12	SC-22924	HHCS, M6 X 20, W/NO MARKING	1
13	SC-22271	SCREW, M4 X 6MM PH	8
14	SN-38111	SENSOR, 1000 OHM, 110" WIRE	1
15	BK-29605	BLOCK, SENSOR, ELEC. CONTROL	2
16	1493	GUARD SENSOR, W/MW	2
17	BU-3378	1 1/8" SNAP BUSHING	4
18	SN-38110	SENSOR, 100 OHM, 110" WIRE,	2
19	IN-22364	INSULATION @ 24" x 108"	2
20	5015108	1000/1200 SERIES SS P/T	1

1200-UP Core Assembly, Pass-Thru, Deluxe with Timer

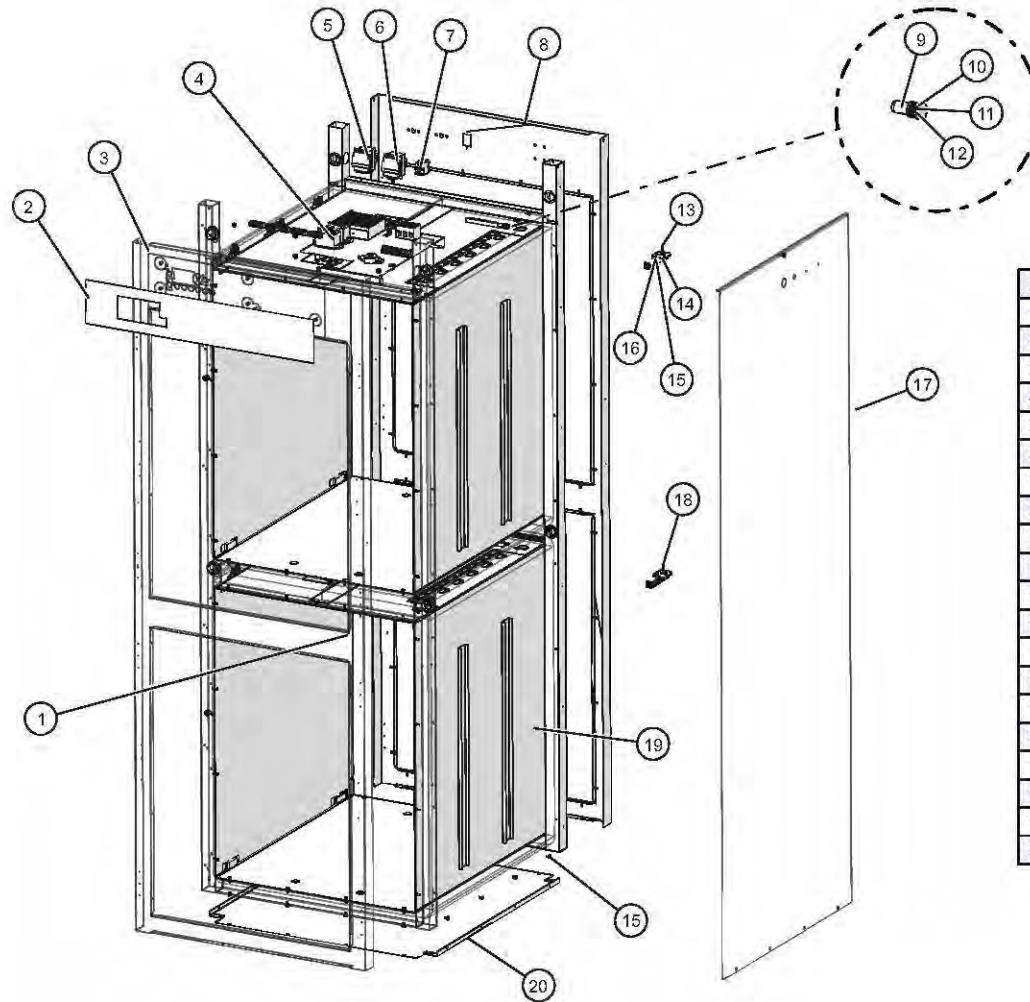

ID	Part No.	Description	Qty
1	5034314	SWITCH, REED, ASSEMBLY	4
2	PE-27936	1200-UP ELECTRONIC W/ TIMER	1
3	5012660	1200-UP ELEC FRONT TRIM STUD WELD	1
4	5034606	CHASSIS, DELUXE DOUBLES	1
5	TT-34600	THERMOSTAT, 300F HI-LIMIT	1
6	TT-33476	THERMOSTAT, 300F HI-LIMIT	1
7	SW-38665	SWITCH, ROCKER, DPST, 20A, 125V,	1
8	5034600	TRIM, REAR ASSY, PASS-THRU	1
9	NU-22770	NUT, THREADED INSERT, M6	1
10	WS-22297	WASHER, FLAT	2
11	WS-22302	WASHER, SPLIT LOCK	2
12	SC-22924	HHCS, M6 X 20, W/NO MARKING	1
13	SN-38111	SENSOR, 1000 OHM, 110" WIRE	2
14	BK-29605	BLOCK, SENSOR, ELEC. CONTROL	2
15	SC-22271	SCREW, M4x0.7X6MM PAN	8
16	1493	GUARD SENSOR, W/MW	2
17	5015108	1000/1200 SERIES SS P/T	1
18	SN-38110	SENSOR, 100 OHM, 110" WIRE,	1
19	IN-22364	INSULATION @ 24" x 108"	2
20	1011650	BOTTOM PANEL, 1200-S/UP	1

1200-UP Core Assembly, Pass-Thru, 2000W Deluxe

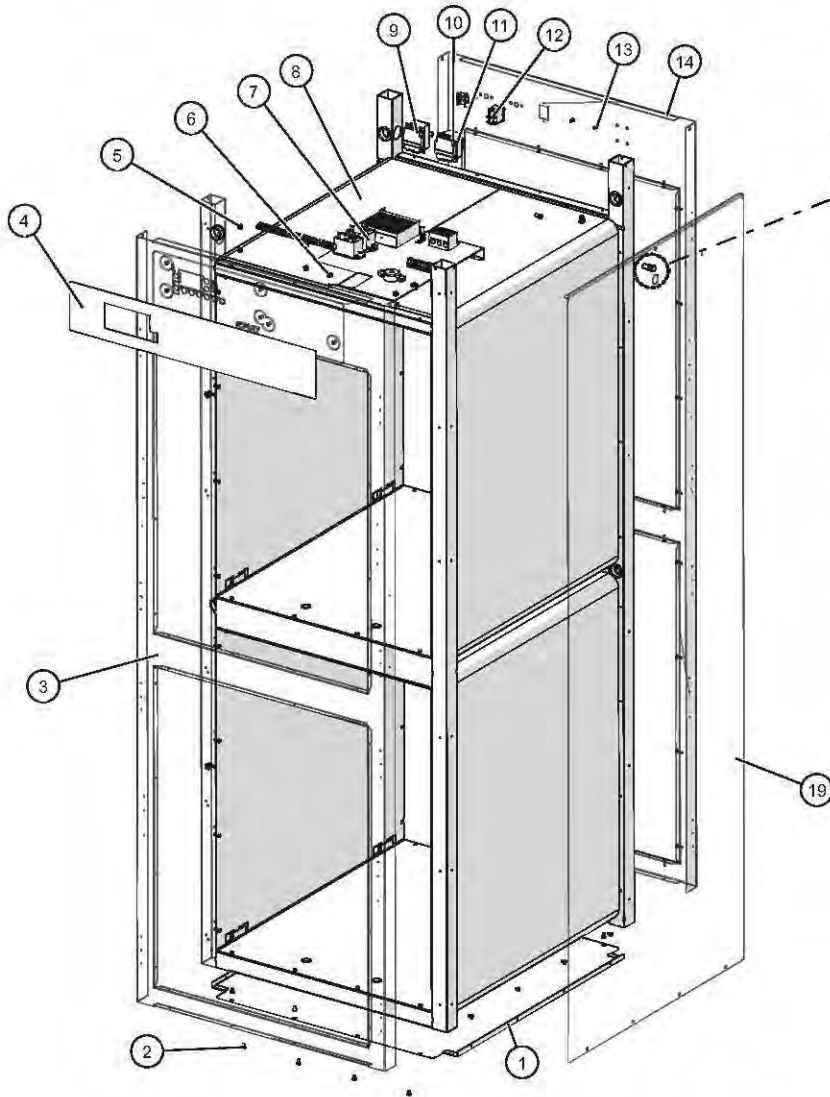

ID	Part No.	Description	Qty
1	1011650	BOTTOM PANEL,1200-S/UP	1
2	SC-22271	SCREW, M4 X 6MM PH PAN HD M/S .7	20
3	5034626	TRIM,FRONT,DX,OVERLAY ASSY	1
4	PE-27855	1200-UP, ELEC, OVERLAY	1
5	NU-26526	NUT, #8-32 UNC KEPS ZP	4
6	NU-2296	NUT, HEX #8-32	2
7	5034606	WARMER SERIES DELUXE DOUBLES,	1
8	5014416	CAVITY PKG,PASS-THRU,2000W	1
9	TT-34600	THERMOSTAT, 300F HI-LIMIT	1
10	TT-33476	THERMOSTAT, 300F HI-LIMIT	1
11	1003936	HI-LIMIT PROTECTION COVER	2
12	SW-38665	SWITCH,ROCKER,DPST,20A,125V,	1
13	RI-38125	RIVET,SEALED,.125", GRIP .039-.118	2
14	5034600	TRIM,REAR ASSY,PASS-THRU	1
15	WS-22297	WASHER, FLAT, M6, 18-8 SST	2
16	WS-22302	WASHER, SPLIT LOCK, M6, 18-8 SST	2
17	SC-22924	HHCS, M6 X 20, W/NO MARKING	1
18	NU-22770	NUT, THREADED INSERT, M6	1
19	5015108	1000/1200 SERIES SS P/T	1

1200-UP Core Assembly, Reach-In, Deluxe with Timer

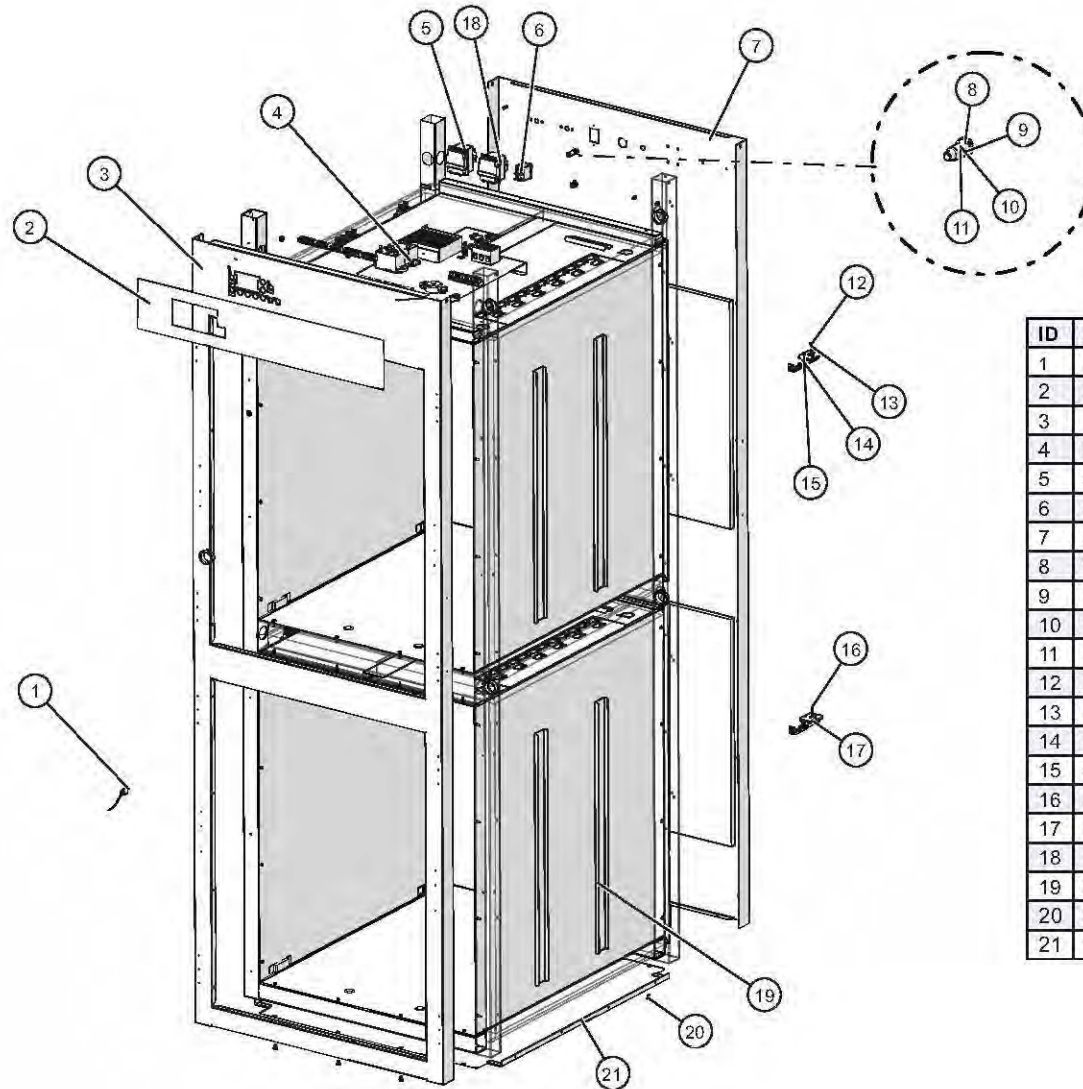

ID	Part No.	Description	Qty
1	5034314	SWITCH, REED, ASSEMBLY	1
2	PE-27936	1200-UP ELECTRONIC W/ TIMER	1
3	5012660	1200-UP ELEC FRONT TRIM	1
4	5034606	CHASSIS, DELUXE DOUBLES	1
5	5034668	MOUNTING, CONTROL, ASSY, DX	1
6	SW-38665	SWITCH, ROCKER, DPST, 20A, 125V,	1
7	5034644	PANEL ASSY, REACH-IN, BACK	1
8	WS-22297	WASHER, FLAT, M6, 18-8 SST	2
9	SC-22924	HHCS, M6 X 20, W/NO MARKING	1
10	WS-22302	WASHER, SPLIT LOCK, M6, 18-8 SST	2
11	NU-22770	NUT, THREADED INSERT, M6	1
12	SN-38110	SENSOR, 100 OHM, 110" WIRE,	1
13	SN-38111	SENSOR, 1000 OHM, 110" WIRE	2
14	1493	GUARD SENSOR, W/MW	2
15	SC-22271	SCREW, PAN HEAD M4 X 7MM	4
16	SN-38110	SENSOR, 100 OHM, 110" WIRE,	1
17	BK-29605	BLOCK, SENSOR, ELEC. CONTROL	2
18	1003936	HI-LIMIT PROTECTION COVER	2
19	IN-22364	INSULATION @ 24" x 108"	2
20	SC-22271	SCREW, PAN HEAD M4 X 7MM	8
21	1011650	BOTTOM PANEL, 1200-S/UP	1

1200-UP Core Assembly, Reach-In, Deluxe with Timer

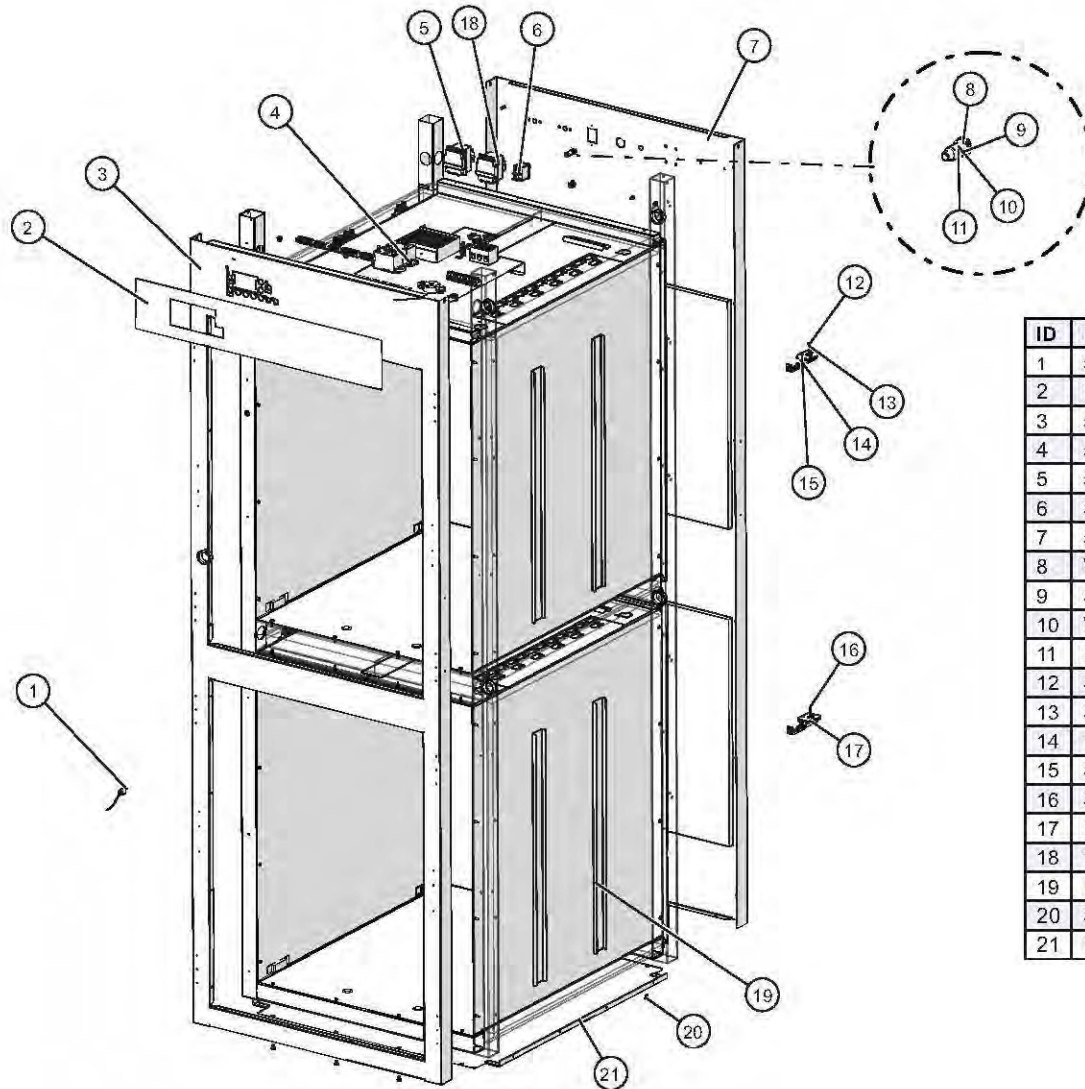

ID	Part No.	Description	Qty
1	5034314	SWITCH, REED, ASSEMBLY	1
2	PE-27936	1200-UP ELECTRONIC W/ TIMER	1
3	5012660	1200-UP ELEC FRONT TRIM	1
4	5034606	CHASSIS, DELUXE DOUBLES	1
5	5034668	MOUNTING, CONTROL, ASSY, DX	1
6	SW-38665	SWITCH, ROCKER, DPST, 20A, 125V,	1
7	5034644	PANEL ASSY, REACH-IN, BACK	1
8	WS-22297	WASHER, FLAT, M6, 18-8 SST	2
9	SC-22924	HHCS, M6 X 20, W/NO MARKING	1
10	WS-22302	WASHER, SPLIT LOCK, M6, 18-8 SST	2
11	NU-22770	NUT, THREADED INSERT, M6	1
12	SN-38110	SENSOR, 100 OHM, 110" WIRE,	1
13	SN-38111	SENSOR, 1000 OHM, 110" WIRE	2
14	1493	GUARD SENSOR, W/MW	2
15	SC-22271	SCREW, PAN HEAD M4 X 7MM	4
16	SN-38110	SENSOR, 100 OHM, 110" WIRE,	1
17	BK-29605	BLOCK, SENSOR, ELEC. CONTROL	2
18	1003936	HI-LIMIT PROTECTION COVER	2
19	IN-22364	INSULATION @ 24" x 108"	2
20	SC-22271	SCREW, PAN HEAD M4 X 7MM	8
21	1011650	BOTTOM PANEL, 1200-S/UP	1

1200-UP Core Assembly, Pass-Thru, Deluxe 2000W

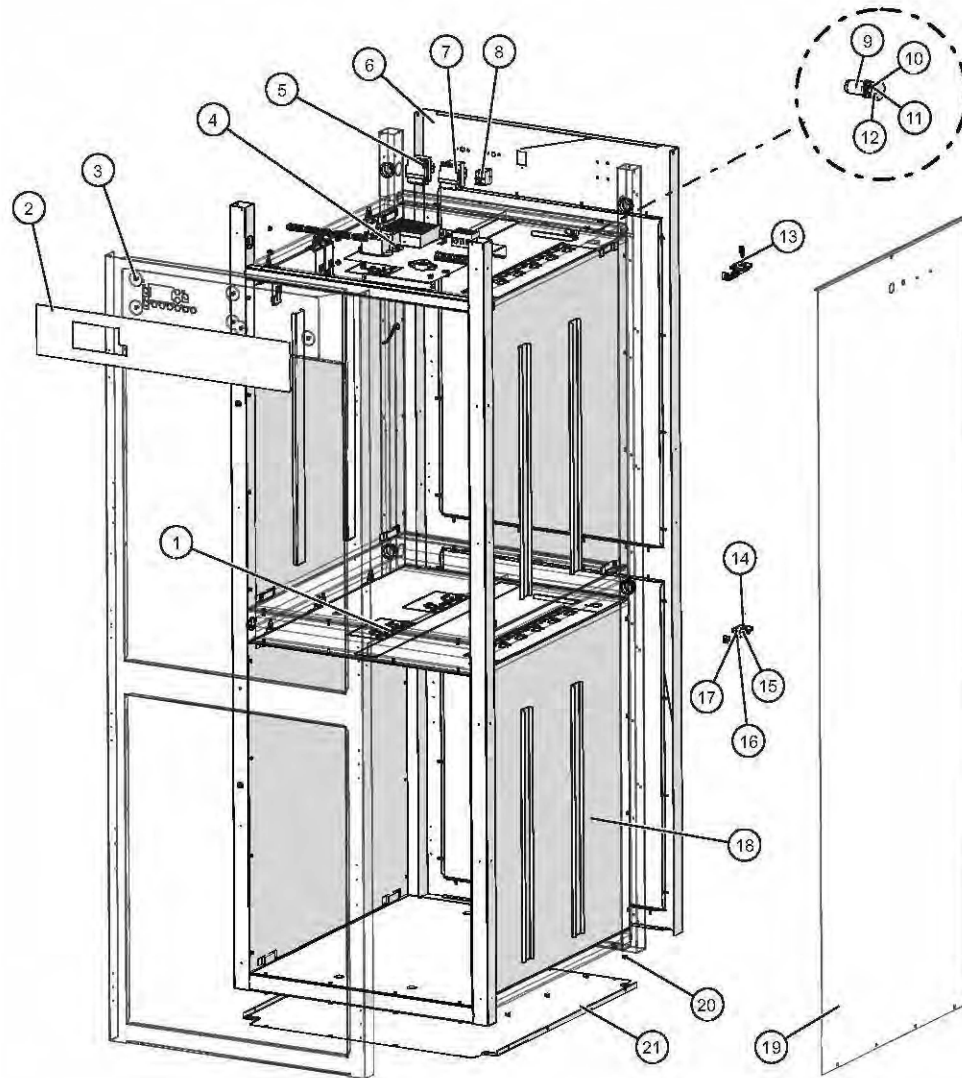

ID	Part No.	Description	Qty
1	5034314	SWITCH, REED, ASSEMBLY	4
2	PE-27855	1200-UP, ELEC, OVERLAY	1
3	5012660	1200-UP ELEC FRONT TRIM	1
4	5034606	CHASSIS, DELUXE DOUBLES	1
5	TT-34600	THERMOSTAT, 300F HI-LIMIT	1
6	5034600	TRIM, REAR ASSY, PASS-THRU	1
7	TT-33476	THERMOSTAT, 300F HI-LIMIT	1
8	SW-38665	SWITCH, ROCKER, DPST, 20A, 125V,	1
9	NU-22770	NUT, THREADED INSERT, M6	2
10	WS-22297	WASHER, FLAT	4
11	WS-22302	WASHER, SPLIT LOCK	4
12	SC-22924	HHCS, M6 X 20, W/NO MARKING	2
13	SN-47162	SENSOR, 1000 OHM, 40" WIRE	1
14	SN-38111	SENSOR, 1000 OHM, 110" WIRE	1
15	BK-29605	BLOCK, SENSOR, ELEC. CONTROL	2
16	SC-22271	SCREW, M4x0.7X6MM PAN	4
17	1493	GUARD SENSOR, W/MW	2
18	IN-22364	INSULATION @ 24" x 108"	2
19	5015108	1000/1200 SERIES SS P/T	1
20	SC-22271	SCREW, M4x0.7X6MM PAN	4
21	1011650	BOTTOM PANEL, 1200-S/UP	1

1200-UP Core Assembly, Pass-Thru w/Timer, Deluxe 2000W

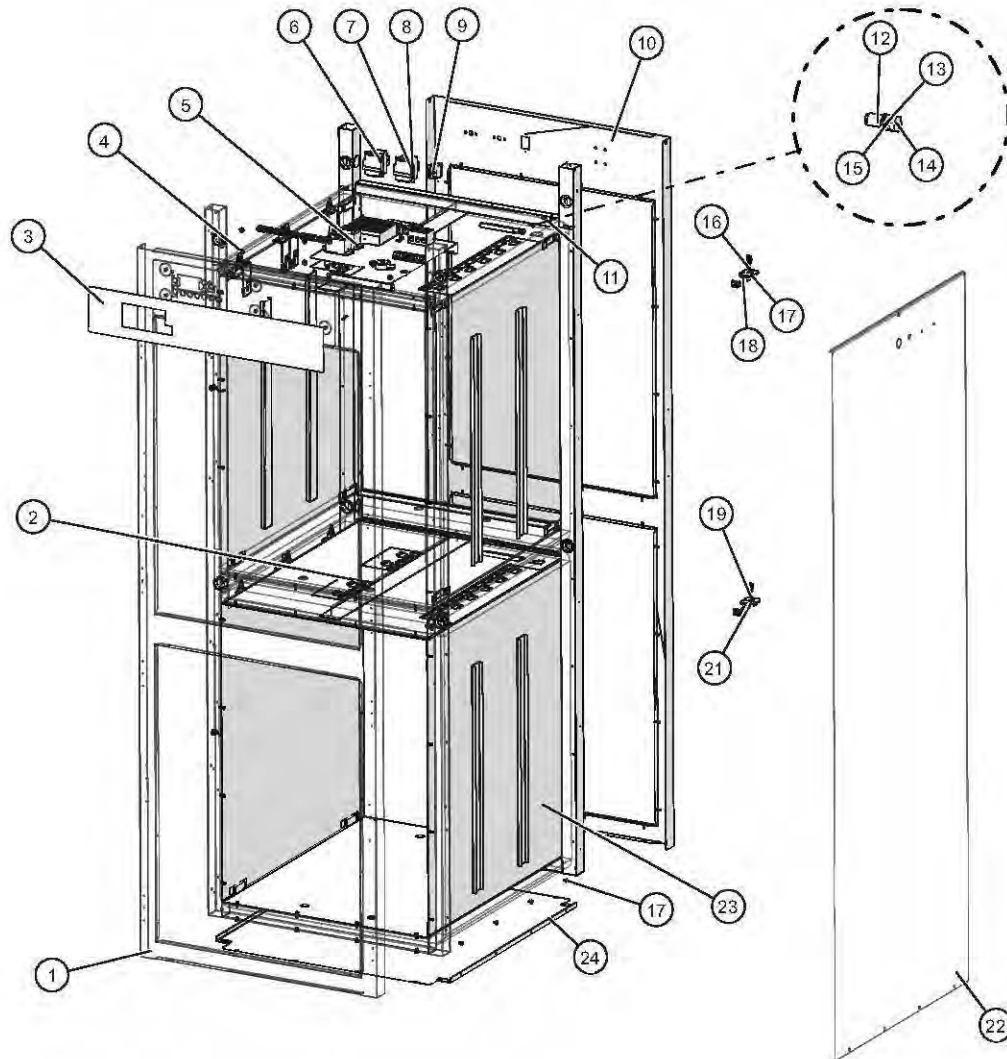

ID	Part No.	Description	Qty
1	5012660	1200-UP ELEC FRONT TRIM	1
2	5034314	SWITCH, REED, ASSEMBLY	4
3	PE-27936	1200-UP ELECTRONIC W/ TIMER	1
4	NU-26526	NUT, #8-32 UNC KEPS ZP	4
5	5034606	CHASSIS, DELUXE DOUBLES	1
6	TT-34600	THERMOSTAT, 300F HI-LIMIT	1
7	TT-33476	THERMOSTAT, 300F HI-LIMIT	1
8	1003936	HI-LIMIT PROTECTION COVER	2
9	SW-38665	SWITCH,ROCKER,DPST,20A,125V,	1
10	5034600	TRIM,REAR ASSY,PASS-THRU	1
11	RI-38125	RIVET,SEALED,.125"	2
12	NU-22770	NUT, THREADED INSERT, M6	2
13	WS-22297	WASHER, FLAT	2
14	SC-22924	HHCS, M6 X 20, W/NO MARKING	1
15	WS-22302	WASHER, SPLIT LOCK	2
16	SN-47162	SENSOR, 1000 OHM, 40" WIRE	1
17	SC-22271	SCREW,M4x0.7X6MM PAN	12
18	1493	GUARD SENSOR,W/MW	2
19	SN-38111	SENSOR, 1000 OHM, 110" WIRE	1
21	BK-29605	BLOCK, SENSOR, ELEC. CONTROL	2
22	1038311	SIDE PANEL 1000/1200 SERIES	1
23	IN-22364	INSULATION @ 24" x 108"	2
24	1011650	BOTTOM PANEL, 1200-S/UP	1

1200-UP Core Assembly, Reach-In, 2000W Deluxe w/Timer

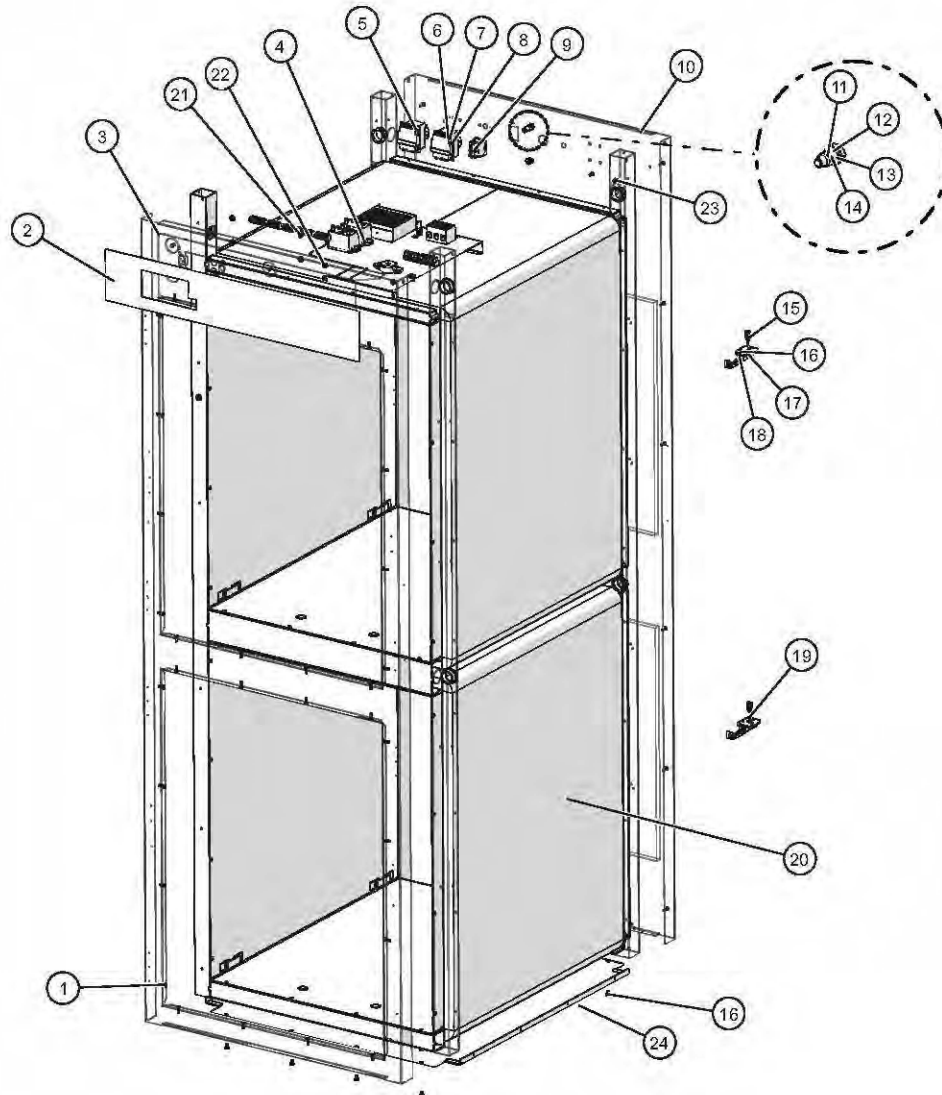

ID	Part No.	Description	Qty
1	RI-27108	RIVET, SEALED, 0.125"x0.45"	44
2	PE-27936	1200-UP ELECTRONIC W/ TIMER	1
3	5034601	TRIM W/TIMER,ELEC,FRONT	1
4	5034606	WARMER SERIES DELUXE DOUBLES,	1
5	TT-34600	THERMOSTAT, 300F HI-LIMIT, MANUAL RESET	1
6	SC-22271	SCREW, PAN HEAD M4 X 7MM	4
7	TT-33476	THERMOSTAT, 300F HI-LIMIT,DPST 16A	1
8	1003936	HI-LIMIT PROTECTION COVER	2
9	SW-38665	SWITCH,ROCKER,DPST,20A,125V,	1
10	5034644	PANEL ASSY,REACH-IN,BACK	1
11	WS-22302	WASHER, SPLIT LOCK, M6, 18-8 SST	2
12	WS-22297	WASHER, FLAT, M6, 18-8 SST	2
13	SC-22924	HHCS, M6 X 20, W/NO MARKING	1
14	NU-22770	NUT, THREADED INSERT, M6	1
15	SN-47162	SENSOR, 1000 OHM, 40" WIRE,	1
16	SC-22271	SCREW, PAN HEAD M4 X 7MM	12
17	BK-29605	BLOCK, SENSOR, ELEC. CONTROL	2
18	1493	GUARD SENSOR,W/MW	2
19	SN-38111	SENSOR, 1000 OHM, 110" WIRE,	1
20	5014415	CAVITY PKG,REACH-IN,2000W	1
21	NU-26526	NUT, #8-32 UNC KEPS ZP	4
22	NU-2296	NUT, HEX #8-32	2
23	RI-38125	RIVET,SEALED,.125", GRIP .039-.118	2
24	1011650	BOTTOM PANEL,1200-S/UP	1

Heating Wire Service Kits

Cable Heating Kit > (One kit required per compartment)		#4874 (500, 750, 1000)	#4881 (1200 - 4000W)	#4878 (1200 - all but 4000W)
Part No.	Description	Qty	Qty	Qty
CB-3045	Cable Heating Element	—	210 feet (6401cm)	90 feet (2591cm)
CB-3044	Cable Heating Element	120 feet (3658cm)	—	—
CR-3226	Ring Connector	4	12	4
IN-3488	Insulation Corner	1 foot (30,5cm)	1 foot (30,5cm)	1 foot (30,5cm)
BU-3105	Shoulder Bushing	4	12	4
BU-3106	Cup Bushing	4	12	4
ST-2439	Stud	4	12	4
NU-2215	Hex Nut	8	24	8
SL-3063	Insulating Sleeve	4	12	4
TA-3540	Electrical Tape	1 roll	1 roll	1 roll

For heating wire replacement instructions, scan the QR code below.



1200-S Cavity Package "A", Reach-In

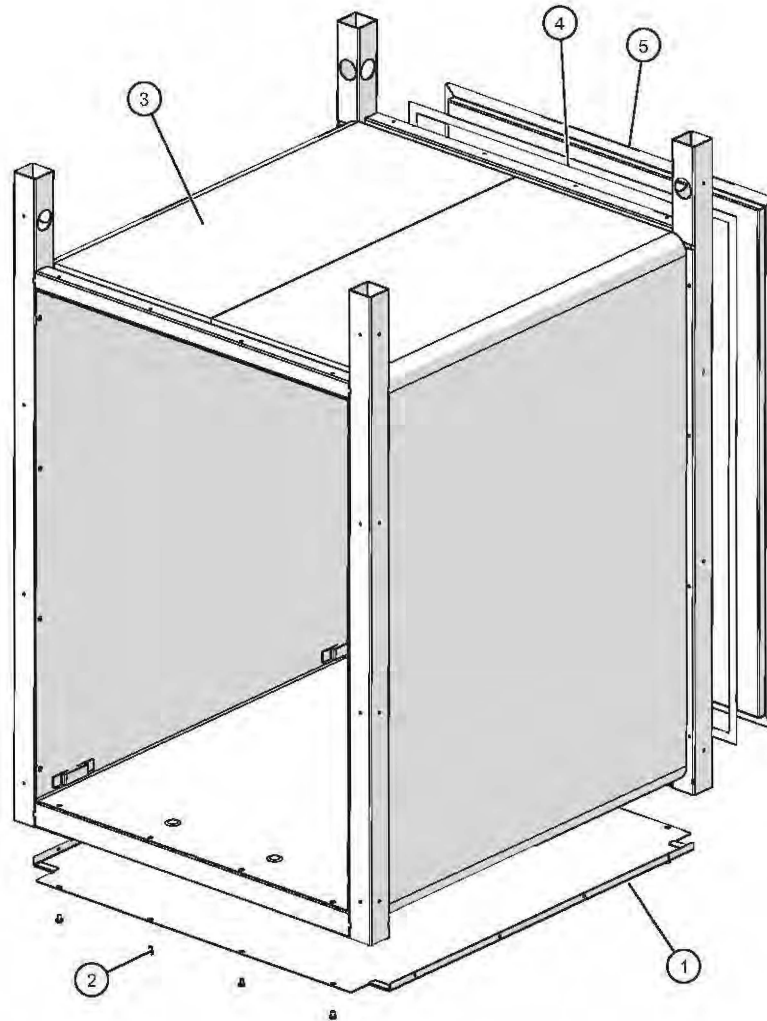

ID	Part No.	Description	Qty
1	1011650	BOTTOM PANEL, 1200-S/UP	1
2	SC-22271	M4 X 6MM PH PAN HD M/S .7	8
3	5012737	1200-S 1000W CABLE INSULATION ASSB	1
4	TA-24637	.5" WIDE X 25 MIL VHB TAPE	1
5	1011654	1200-S/UP, INNER BACK PANEL	1

1200-S Cavity Package "B", Pass-Thru

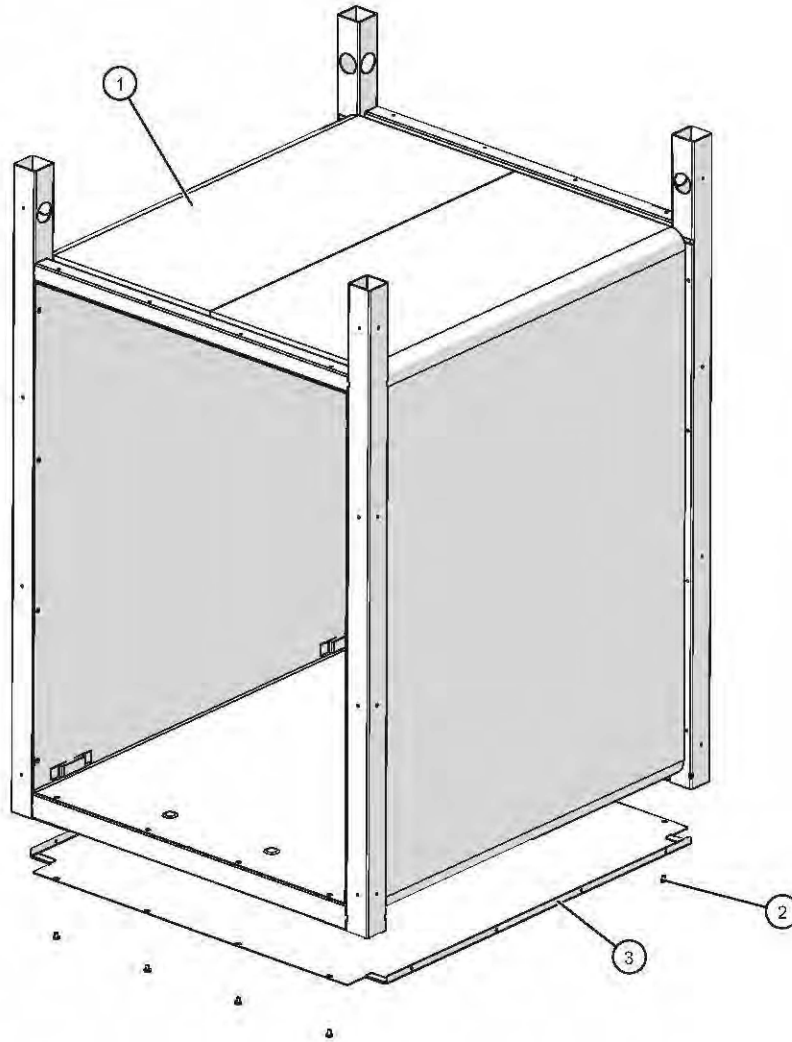

ID	Part No.	Description	Qty
1	5012737	1200-S 1000W CABLE INSULATION ASSB	1
2	SC-22271	SCREW, M4x0.7X6MM PAN	8
3	1011650	BOTTOM PANEL, 1200-S/UP	1

1200-S Cavity Package "C", Reach-In 2000W

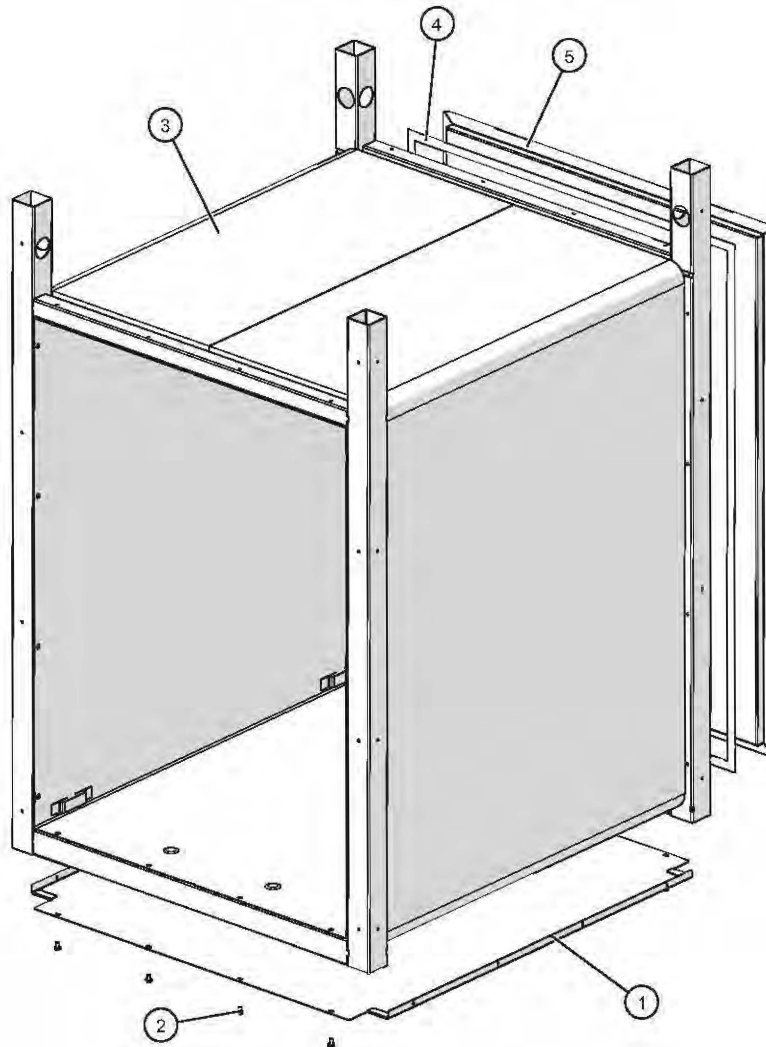

ID	Part No.	Description	Qty
1	1011650	BOTTOM PANEL, 1200-S/UP	1
2	SC-22271	M4 X 6MM PH PAN HD M/S .7	8
3	5012747	1200-S 2000W CABLE INSULATION ASSB	1
4	TA-24637	.5" WIDE X 25 MIL VHB TAPE	1
5	1011654	1200-S/UP, INNER BACK PANEL	1

1200-S Cavity Package "D", Pass-Thru 2000W

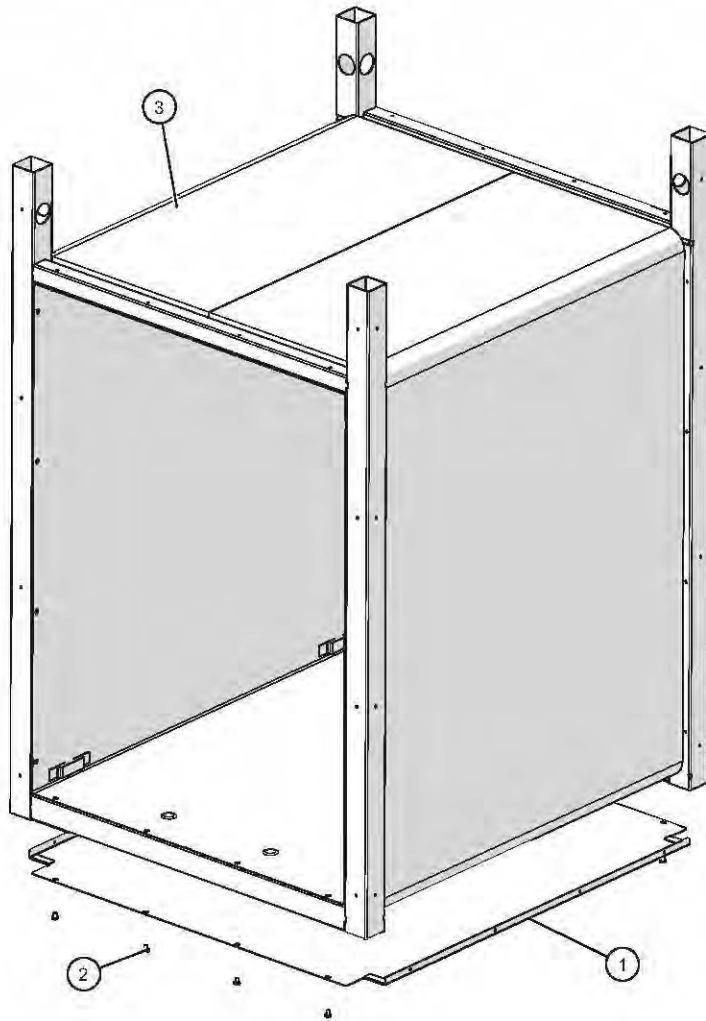

ID	Part No.	Description	Qty
1	1011650	BOTTOM PANEL, 1200-S/UP	1
2	SC-22271	SCREW, M4x0.7X6MM PAN	8
3	5012747	1200-S 2000W CABLE INSULATION ASSB	1

1200-UP Cavity Package "A", Reach-In

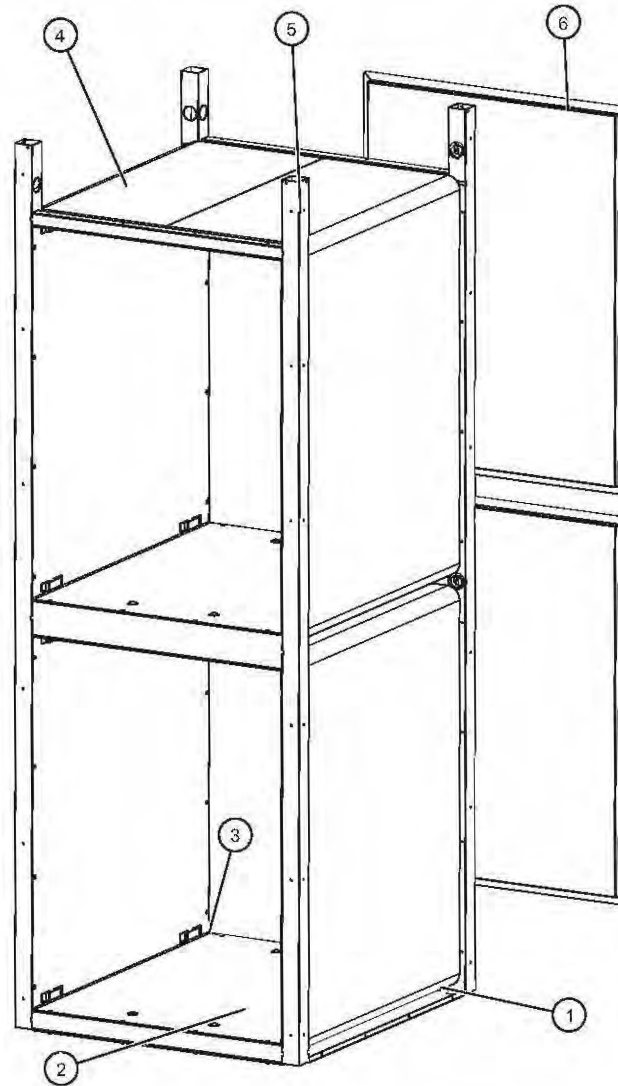

ID	Part No.	Description	Qty
1	SC-22271	M4 X 6MM PH PAN HD M/S .7	8
2	1011650	BOTTOM PANEL, 1200-S/UP	1
3	TA-24637	.5" WIDE X 25 MIL VHB TAPE	2
4	5012351	CABLE INSULATION 1200-UP	1
5	BU-3378	1 1/8" SNAP BUSHING	4
6	1011654	1200-S/UP, INNER BACK PANEL	2

1200-UP Cavity Package "B", Pass-Thru

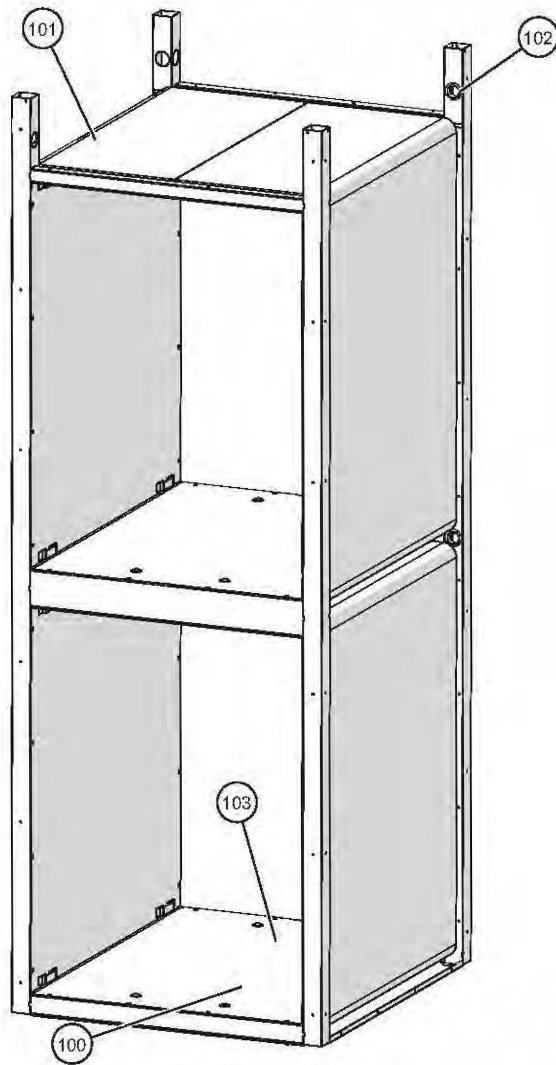

ID	Part No.	Description	Qty
100	1011650	BOTTOM PANEL,1200-S/UP	1
101	5012351	CABLE INSULATION 1200-UP	1
102	BU-3378	1 1/8" SNAP BUSHING	4
103	SC-22271	M4 X 6MM PH PAN HD M/S .7	8

1200-UP Cavity Package "C", Reach-In 4000W

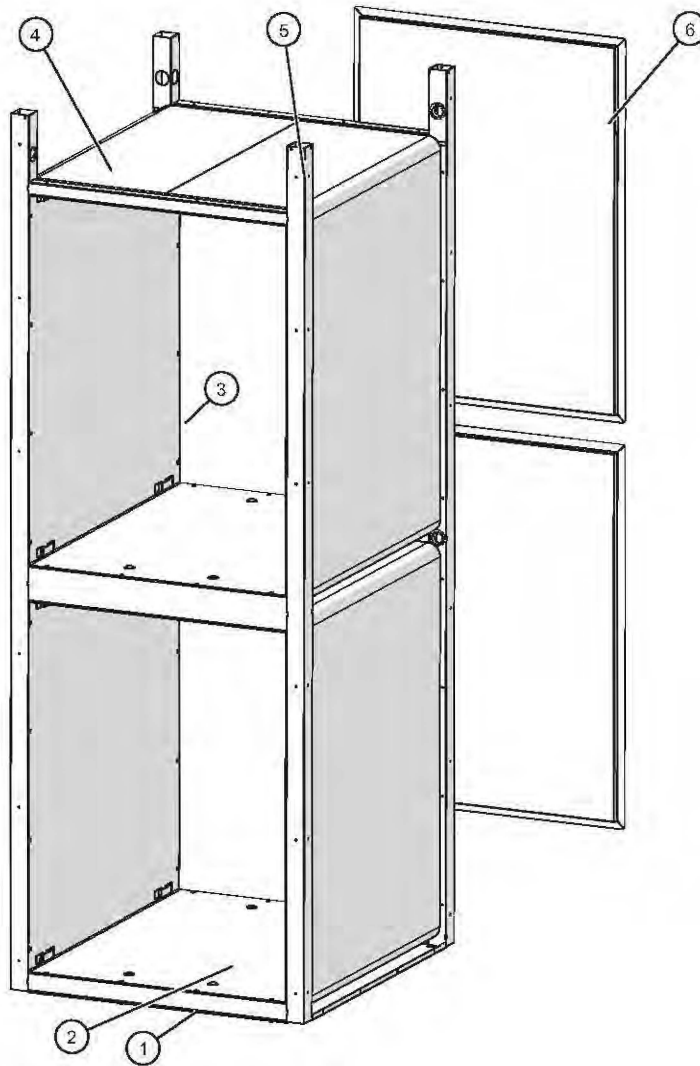

ID	Part No.	Description	Qty
1	SC-22271	M4 X 6MM PH PAN HD M/S .7	8
2	1011650	BOTTOM PANEL, 1200-S/UP	1
3	TA-24637	.5" WIDE X 25 MIL VHB TAPE	2
4	5012673	4000W CABLE INSULATION 1200-UP	1
5	BU-3378	1 1/8" SNAP BUSHING	4
6	1011654	1200-S/UP, INNER BACK PANEL	2

1200-UP Cavity Package, Pass-Thru 4000W

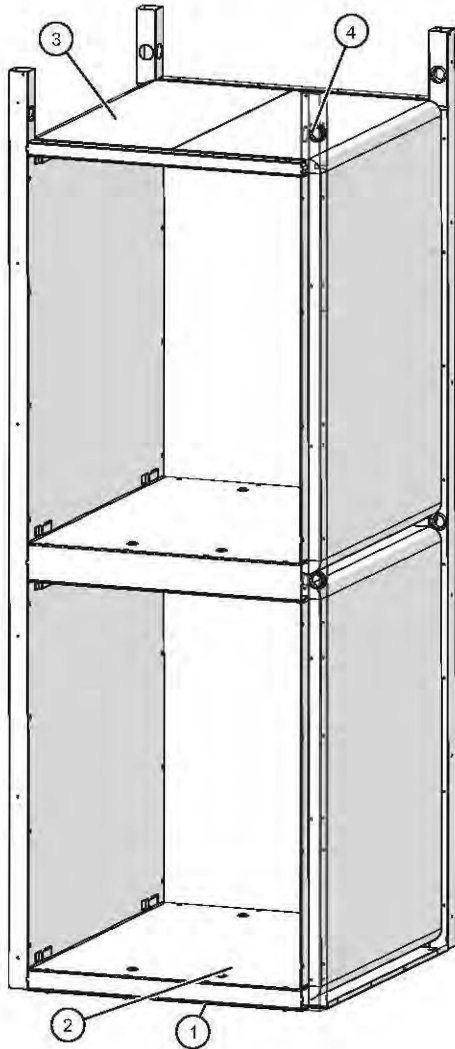

ID	Part No.	Description	Qty
1	SC-22271	M4 X 6MM PH PAN HD M/S .7	8
2	1011650	BOTTOM PANEL, 1200-S/UP	1
3	5012673	4000W CABLE INSULATION 1200-UP	1
4	BU-3378	1 1/8" SNAP BUSHING	4

1200-UP Cavity Package "I", Pass-Thru 4000W

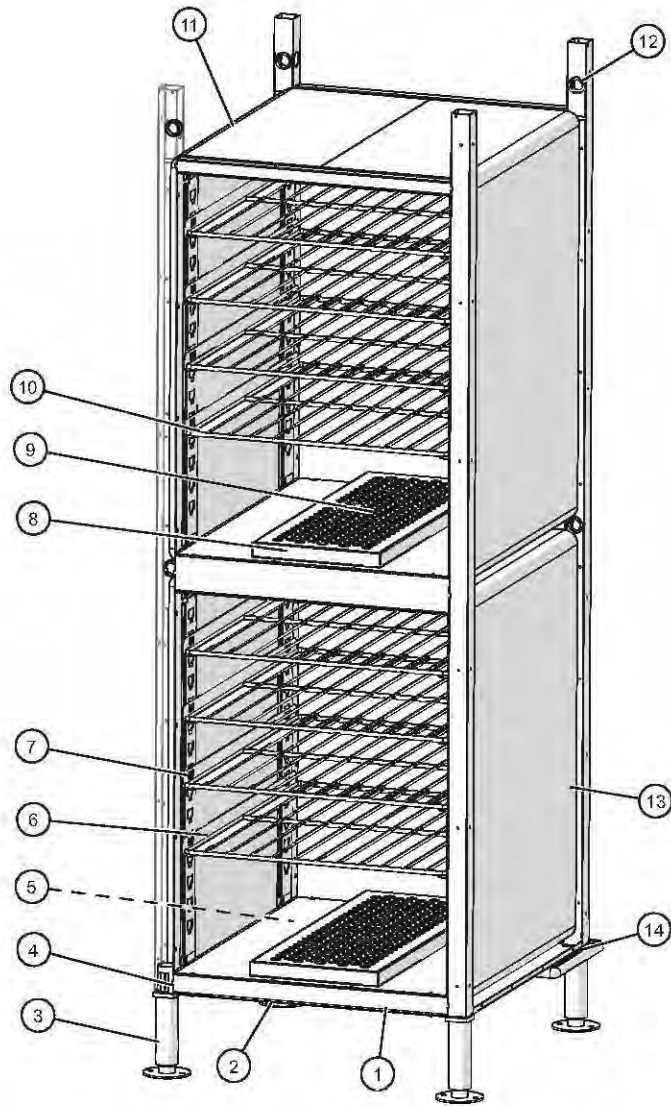

ID	Part No.	Description	Qty
1	1011650	BOTTOM PANEL, 1200-S/UP	1
2	SC-2459	8-32 x 1/4" PHIL SCREW	8
3	LG-23067	6" LEG W/ ADJUSTABLE FLANGED FOOT	4
4	LG-37094	LEG, ADJUST, FOOTING	4
5	4292	ASSB,BUMPER, RH	1
6	1011969	PAN SUPPORT, 1200-UP 2010	16
7	1011968	1200-UP SUPPORT BRACKET	8
8	1775	MOISTURE PAN	2
9	1774	PAN COVER	2
10	SH-2733	SHELF, NICKEL CHROME, 1200-SR	8
11	5012673	4000W CABLE INSULATION 1200-UP	1
12	BU-3378	1 1/8" SNAP BUSHING	8
13	RI-2100	RIVET,BLIND,#44,STNLS	32
14	4291	ASSB,BUMPER, LH	1

1200-S Bonnet Package "A", 120V Manual

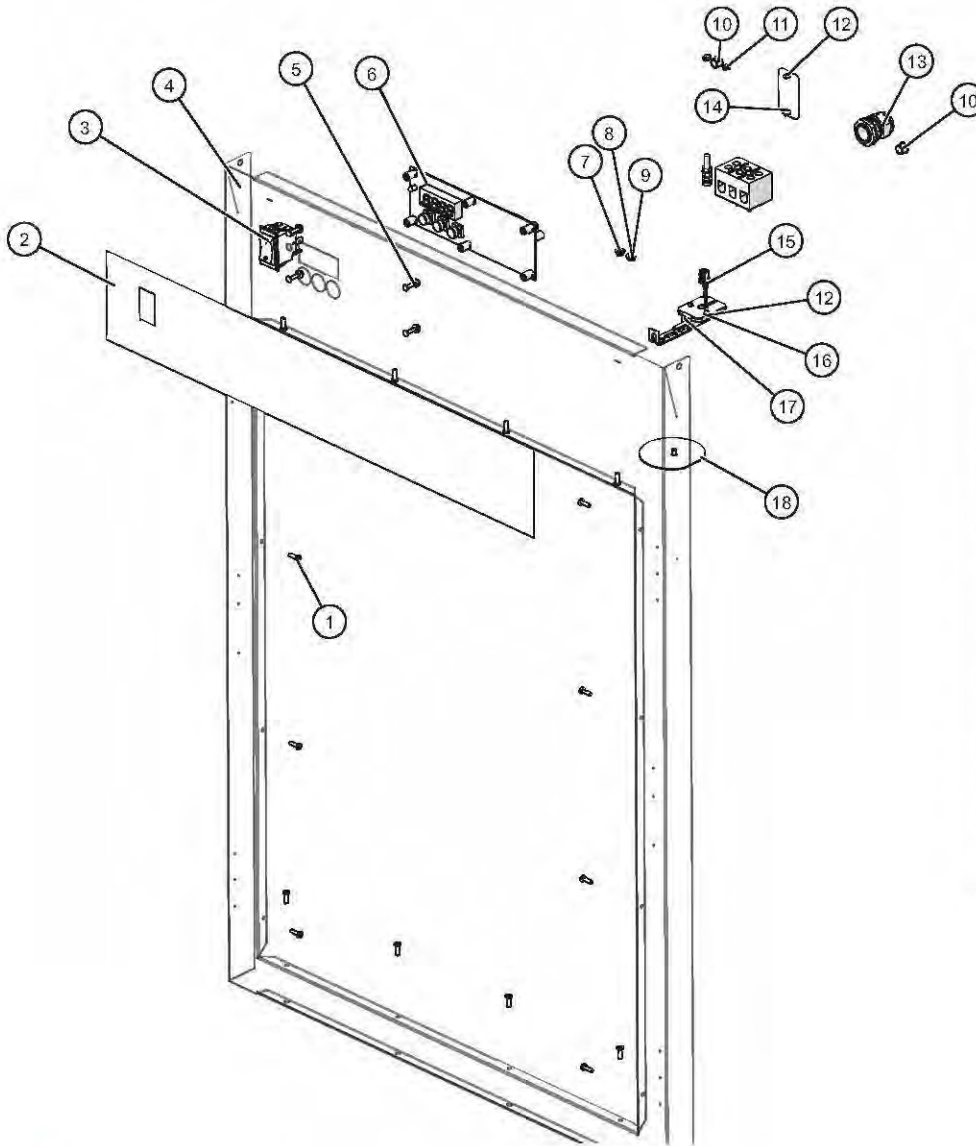

ID	Part No.	Description	Qty
1	RI-27108	RIVET, SEALED	16
2	PE-29397	OVERLAY, 1200-S, ELAN CONTROL	1
3	SW-34769	SWITCH,ROCKER,125-277V,20A	1
4	5012731	1200-S ELAN FRONT TRIM	1
5	WS-23148	WASHER, 6-32, FLAT, NYL	4
6	5012587	1000-S MANUAL 120V,ELE CHASSIS	1
7	WS-23424	WASHER, FLAT, #8, 18-8 SST	2
8	WS-22300	WASHER, SPLIT LOCK	2
9	NU-2361	NUT, 6-32 HEX, S/S	6
10	PG-25574	3/8" HOLE PLUG	2
11	PG-28439	PLUG, DOME,.187" HOLE	2
12	SC-22271	SCREWS,M4-0.7X6MM PHIL	5
13	BU-3964	BUSHING,STRAIGHT,STRAIN RELIEF	1
14	1011697	BREAKER SWITCH CUTOUT COVER	1
15	SN-38111	SENSOR, 1000 OHM, 110" WIRE,	1
16	BK-29605	BLOCK, SENSOR, ELEC. CONTROL	1
17	1493	GUARD SENSOR,W/MW	1
18	1006871	NON-PRODUCT PROBE SEAL	1

1200-S Bonnet Package "B", 208V-240V Manual

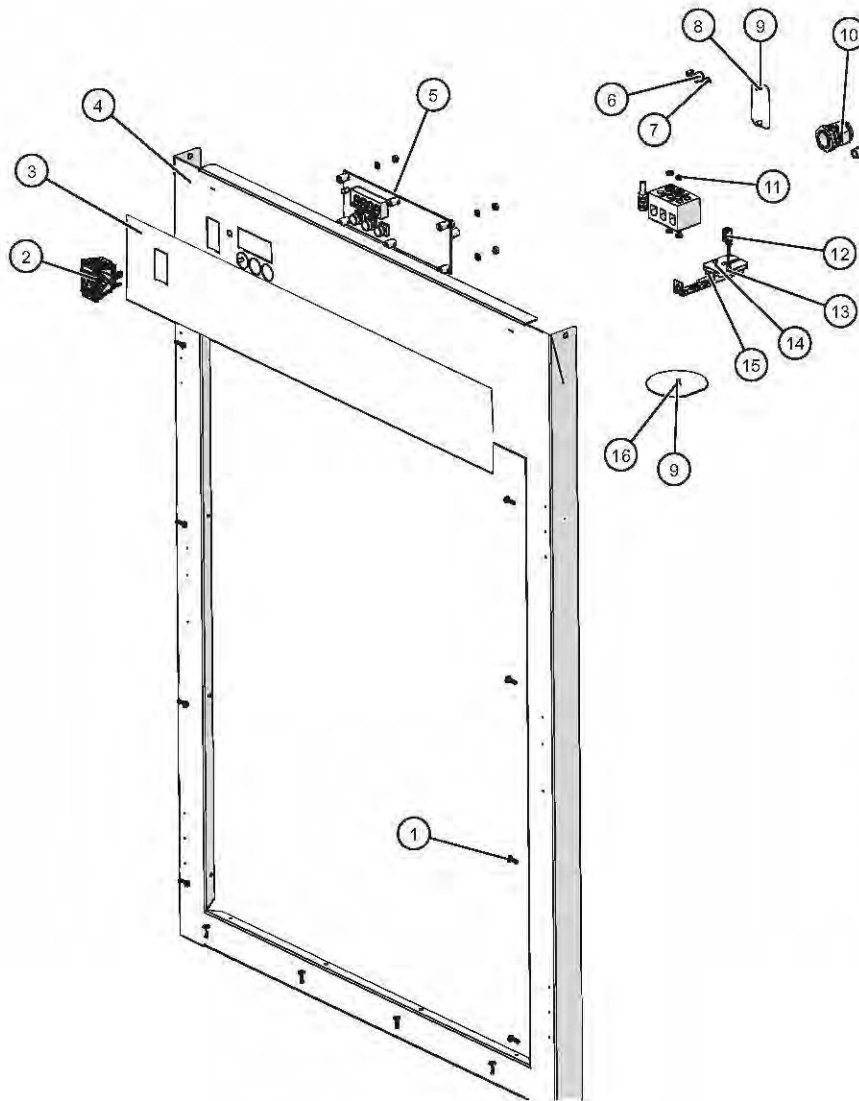

ID	Part No.	Description	Qty
1	RI-27108	RIVET, SEALED	16
2	SW-34769	SWITCH,ROCKER,125-277V,20A	1
3	PE-29397	OVERLAY, 1200-S, ELAN CONTROL	1
4	5012731	1200-S ELAN FRONT TRIM	1
5	5012588	1000-S ELEC CHASSIS 208/240V,	1
6	PG-25574	3/8" HOLE PLUG	2
7	PG-28439	PLUG, DOME, .187" HOLE	2
8	1011697	BREAKER SWITCH CUTOFF COVER	1
9	SC-22271	SCREWS,M4-0.7X6MM PHIL	3
10	BU-3964	BUSHING, STRAIGHT, STRAIN RELIEF	1
11	NU-2361	NUT, 6-32 HEX, S/S	6
12	SN-38111	SENSOR, 1000 OHM, 110" WIRE,	1
13	BK-29605	BLOCK, SENSOR, ELEC. CONTROL	1
14	SC-22271	SCREWS,M4-0.7X6MM PHIL	2
15	1493	GUARD SENSOR,W/MW	1
16	1006871	NON-PRODUCT PROBE SEAL	1

1200-S Bonnet Package "C", 208V-240V 2000W Manual

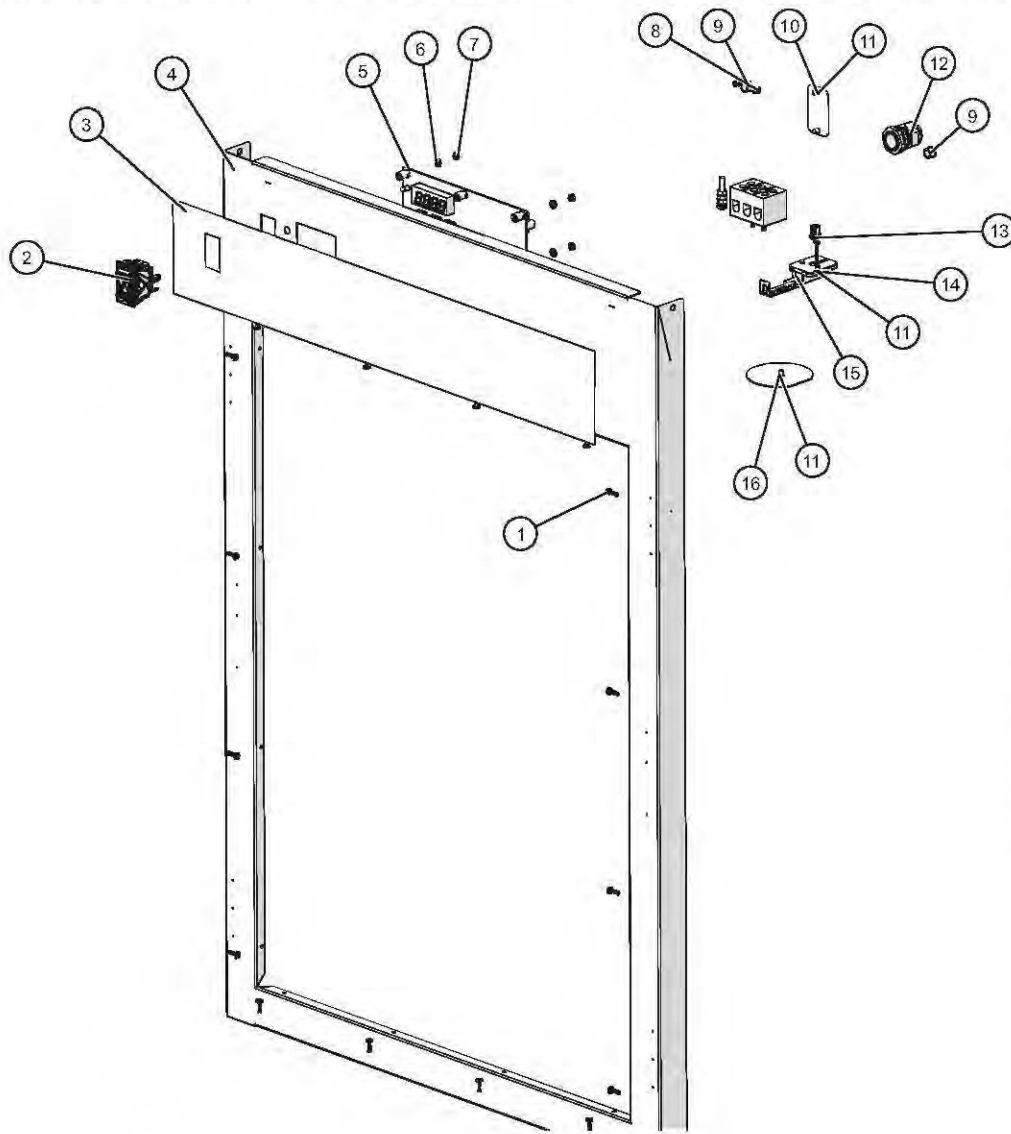

ID	Part No.	Description	Qty
1	RI-27108	RIVET, SEALED	16
2	SW-34769	SWITCH,ROCKER,125-277V,20A	1
3	PE-29397	OVERLAY, 1200-S, ELAN CONTROL	1
4	5012731	1200-S ELAN FRONT TRIM	1
5	5012588	1000-S ELEC CHASSIS 208/240V	1
6	WS-23148	WASHER, 6-32, FLAT, NYL	4
7	NU-2361	NUT, 6-32 HEX, S/S	6
8	PG-28439	PLUG, DOME,.187" HOLE	2
9	PG-25574	3/8" HOLE PLUG	2
10	1011697	BREAKER SWITCH CUTOUT COVER	1
11	SC-22271	SCREWS,M4-0.7X6MM PHIL	5
12	BU-3964	BUSHING,STRAIGHT,STRAIN RELIEF	1
13	SN-38111	SENSOR, 1000 OHM, 110" WIRE,	1
14	BK-29605	BLOCK, SENSOR, ELEC. CONTROL	1
15	1493	GUARD SENSOR,W/MW	1
16	1006871	NON-PRODUCT PROBE SEAL	1

1200-S Bonnet Package "D", 230V Manual

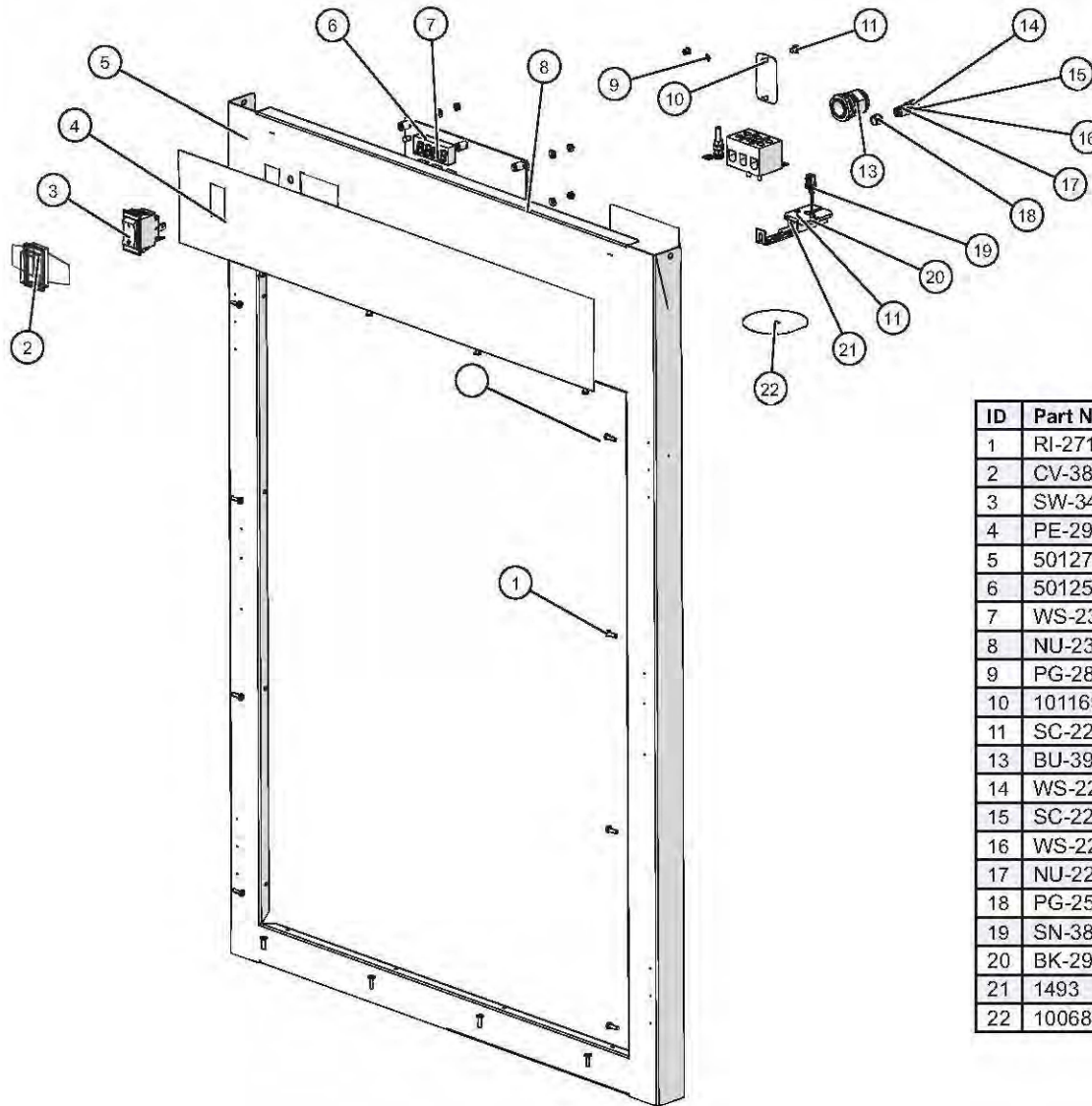

ID	Part No.	Description	Qty
1	RI-27108	RIVET, SEALED	16
2	CV-38297	COVER, IPX RATED, SW-34769	1
3	SW-34769	SWITCH,ROCKER,125-277V,20A	1
4	PE-29397	OVERLAY, 1200-S, ELAN CONTROL	1
5	5012731	1200-S ELAN FRONT TRIM	1
6	5012589	1000-S ELEC CHASSIS 230V	1
7	WS-23148	WASHER, 6-32, FLAT, NYL	4
8	NU-2361	NUT, 6-32 HEX, S/S	6
9	PG-28439	PLUG, DOME,,187" HOLE	2
10	1011697	BREAKER SWITCH CUTOUT COVER	1
11	SC-22271	SCREWS,M4-0.7X6MM PHIL	5
13	BU-3964	BUSHING,STRAIGHT,STRAIN RELIEF	1
14	WS-22297	WASHER, FLAT	2
15	SC-22924	HHCS, M6 X 20, W/NO MARKING	1
16	WS-22302	WASHER, SPLIT LOCK	2
17	NU-22770	NUT, THREADED INSERT, M6	1
18	PG-25574	3/8" HOLE PLUG	1
19	SN-38111	SENSOR, 1000 OHM, 110" WIRE,	1
20	BK-29605	BLOCK, SENSOR, ELEC. CONTROL	1
21	1493	GUARD SENSOR,W/MW	1
22	1006871	NON-PRODUCT PROBE SEAL	1

1200-S Bonnet Package "E", 230V 2000W Manual

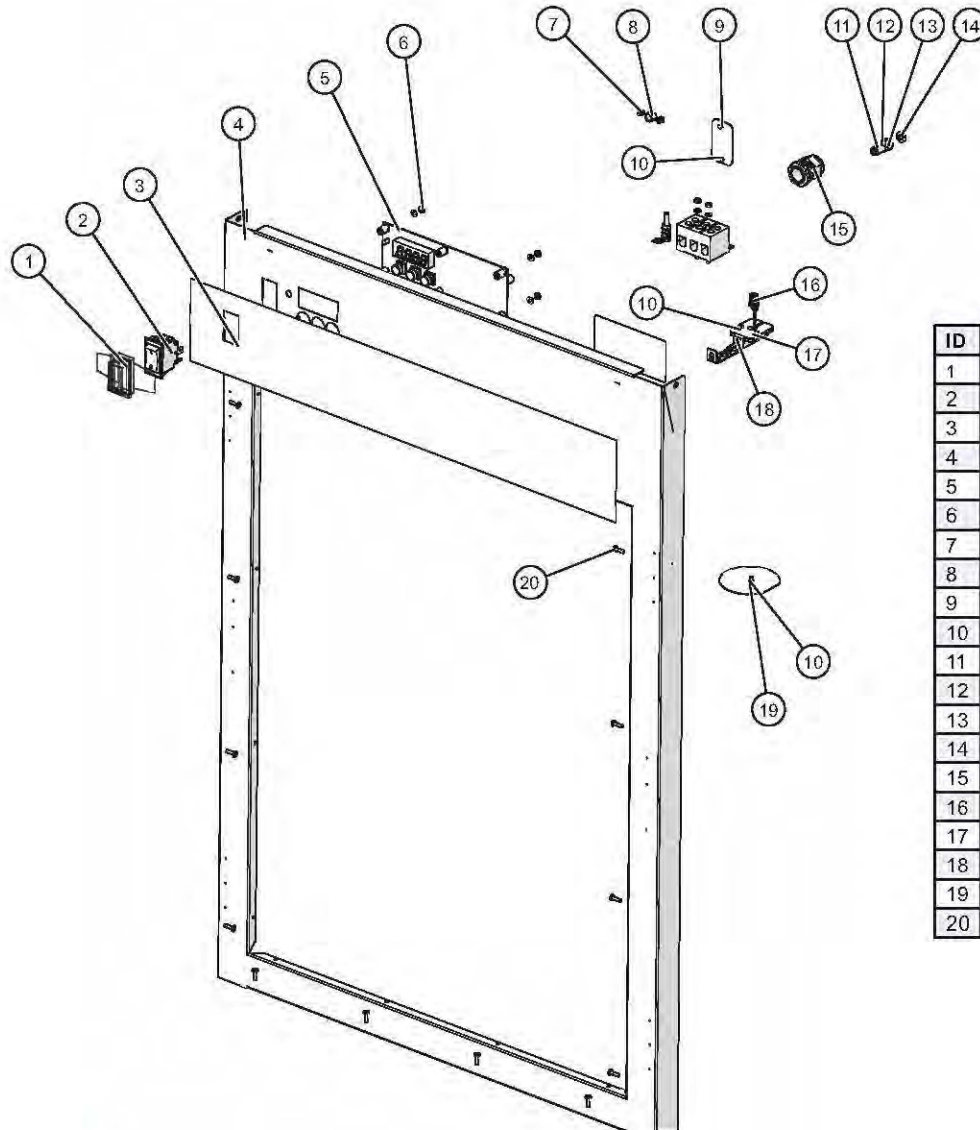

ID	Part No.	Description	Qty
1	CV-38297	COVER, IPX RATED, SW-34769	1
2	SW-34769	SWITCH,ROCKER,125-277V,20A	1
3	PE-29397	OVERLAY, 1200-S, ELAN CONTROL	1
4	5012731	1200-S ELAN FRONT TRIM	1
5	5012589	1000-S MANUAL230V, ELE CHASSIS	1
6	NU-2361	NUT, 6-32 HEX, S/S	6
7	PG-28439	PLUG, DOME,.187" HOLE	2
8	PG-25574	3/8" HOLE PLUG	1
9	1011697	BREAKER SWITCH CUTOUT COVER	1
10	SC-22271	SCREWS,M4-0.7X6MM PHIL	5
11	NU-22770	NUT, THREADED INSERT, M6	1
12	WS-22302	WASHER, SPLIT LOCK, M6 18-8 SST	2
13	SC-22924	HHCS, M6 X 20, W/NO MARKING	1
14	WS-22297	WASHER, FLAT, M6, 18-8 SST	2
15	BU-3964	BUSHING,STRAIGHT,STRAIN RELIEF	1
16	SN-38111	SENSOR, 1000 OHM, 110" WIRE,	1
17	BK-29605	BLOCK, SENSOR, ELEC. CONTROL	1
18	1493	GUARD SENSOR,W/MW	1
19	1006871	NON-PRODUCT PROBE SEAL	1
20	RI-27108	RIVET, SEALED	16

1200-S Bonnet Package "F", 120V Electronic

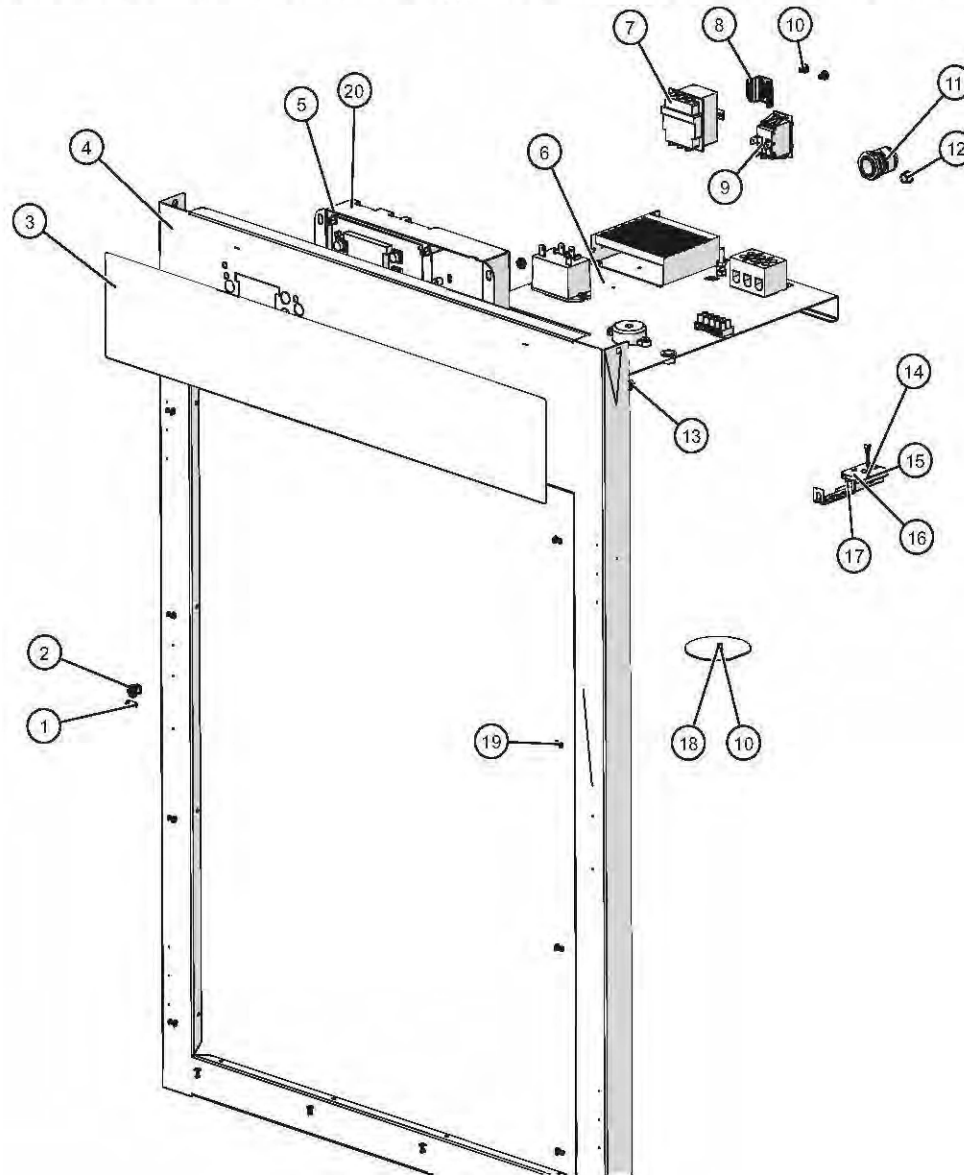

ID	Part No.	Description	Qty
1	SW-33559	SWITCH, REED, SPST	1
2	BU-3419	3/8" BLACK HOLE BUSHING	1
3	PE-28366	1200-S, ELEC, OVERLAY	1
4	5012732	1200-S ELEC FRONT TRIM STUD WELD	1
5	CC-34322	ELECTRONIC WARMER CONTROL	1
6	5012604	1000-S ELEC 120V, ELEC CHASSIS	1
7	TT-33476	THERMOSTAT, 300F HI-LIMIT	1
8	1003936	HI-LIMIT PROTECTION COVER	1
9	SW-34769	SWITCH,ROCKER,125-277V,20A	1
10	SC-22271	SCREWS,M4-0.7X6MM PHIL	3
11	BU-3964	BUSHING,STRAIGHT,STRAIN RELIEF	1
12	PG-25574	3/8" HOLE PLUG	1
13	NU-2296	NUT, HEX #8-32	2
14	SN-38110	SENSOR, 100 OHM, 110" WIRE,	1
15	BK-29605	BLOCK, SENSOR, ELEC. CONTROL	1
16	SC-22271	SCREW,M4x0.7X6MM PAN	2
17	1493	GUARD SENSOR,W/MW	1
18	1006871	NON-PRODUCT PROBE SEAL	1
19	RI-2100	RIVET,BLIND,#44,STNLS	16
20	NU-26526	NUT, #8-32 UNC KEPS ZP	4

1200-S Bonnet Package "G", 208V-240V Electronic

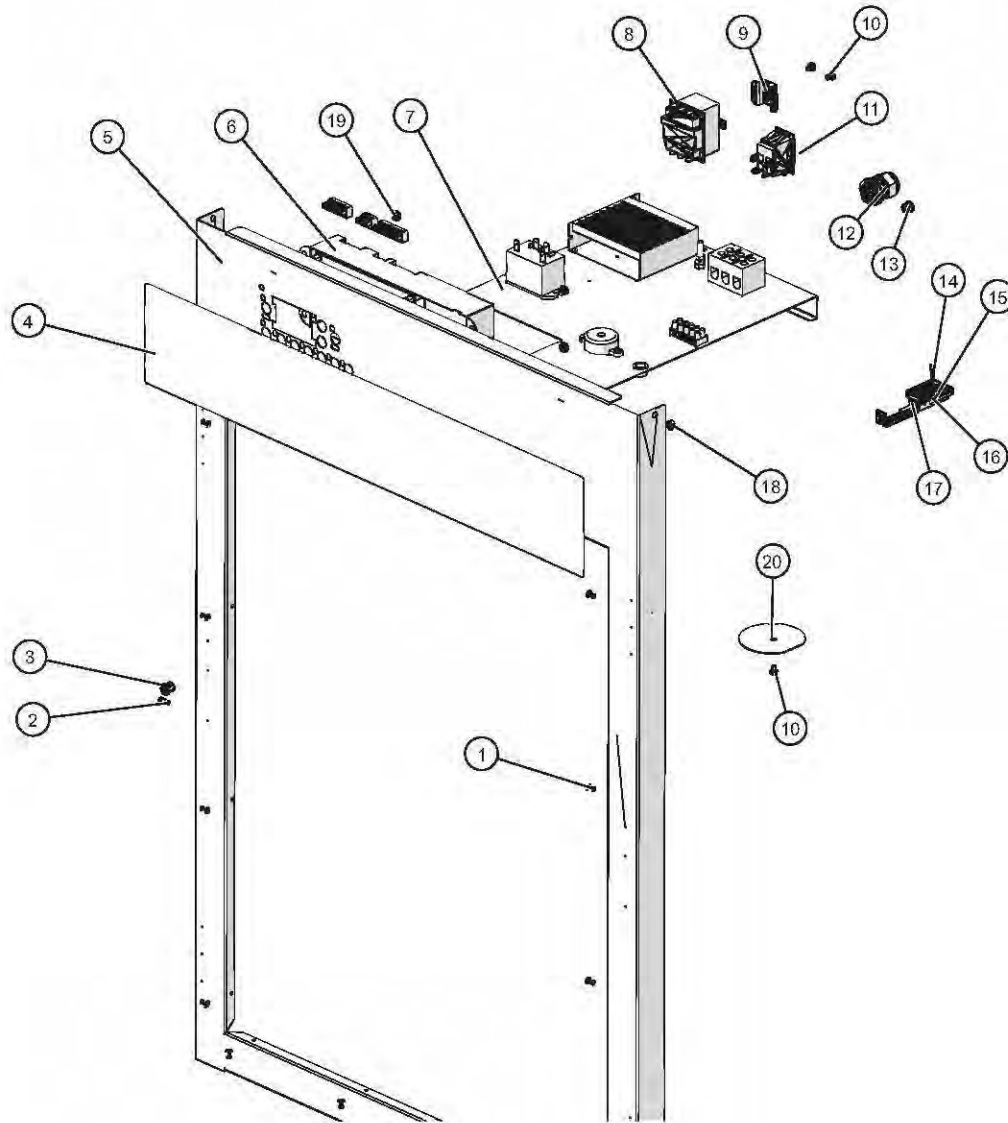

ID	Part No.	Description	Qty
1	RI-2100	RIVET,BLIND,#44,STNLS	16
2	SW-33559	SWITCH, REED, SPST	1
3	BU-3419	3/8" BLACK HOLE BUSHING	1
4	PE-28366	1200-S, ELEC, OVERLAY	1
5	5012732	1200-S ELEC FRONT TRIM ASSY	1
6	CC-34324	CONTROL ASSY W/TIMERS	1
7	5012605	1000-S ELEC CHASSIS 208/240V	1
8	TT-33476	THERMOSTAT, 300F HI-LIMIT	1
9	1003936	HI-LIMIT PROTECTION COVER	1
10	SC-22271	SCREWS,M4-0.7X6MM PHIL	3
11	SW-34769	SWITCH,ROCKER,125-277V,20A	1
12	BU-3964	BUSHING, STRAIGHT,STRAIN RELIEF	1
13	PG-25574	3/8" HOLE PLUG	1
14	SN-38110	SENSOR, 100 OHM, 110" WIRE,	1
15	SC-22271	SCREW,M4x0.7X6MM PAN	2
16	BK-29605	BLOCK, SENSOR, ELEC. CONTROL	1
17	1493	GUARD SENSOR,W/MW	1
18	NU-2296	NUT, HEX #8-32	2
19	NU-26526	NUT, #8-32 UNC KEPS ZP	4
20	1006871	NON-PRODUCT PROBE SEAL	1

1200-S Bonnet Package "I", 230V Electronic

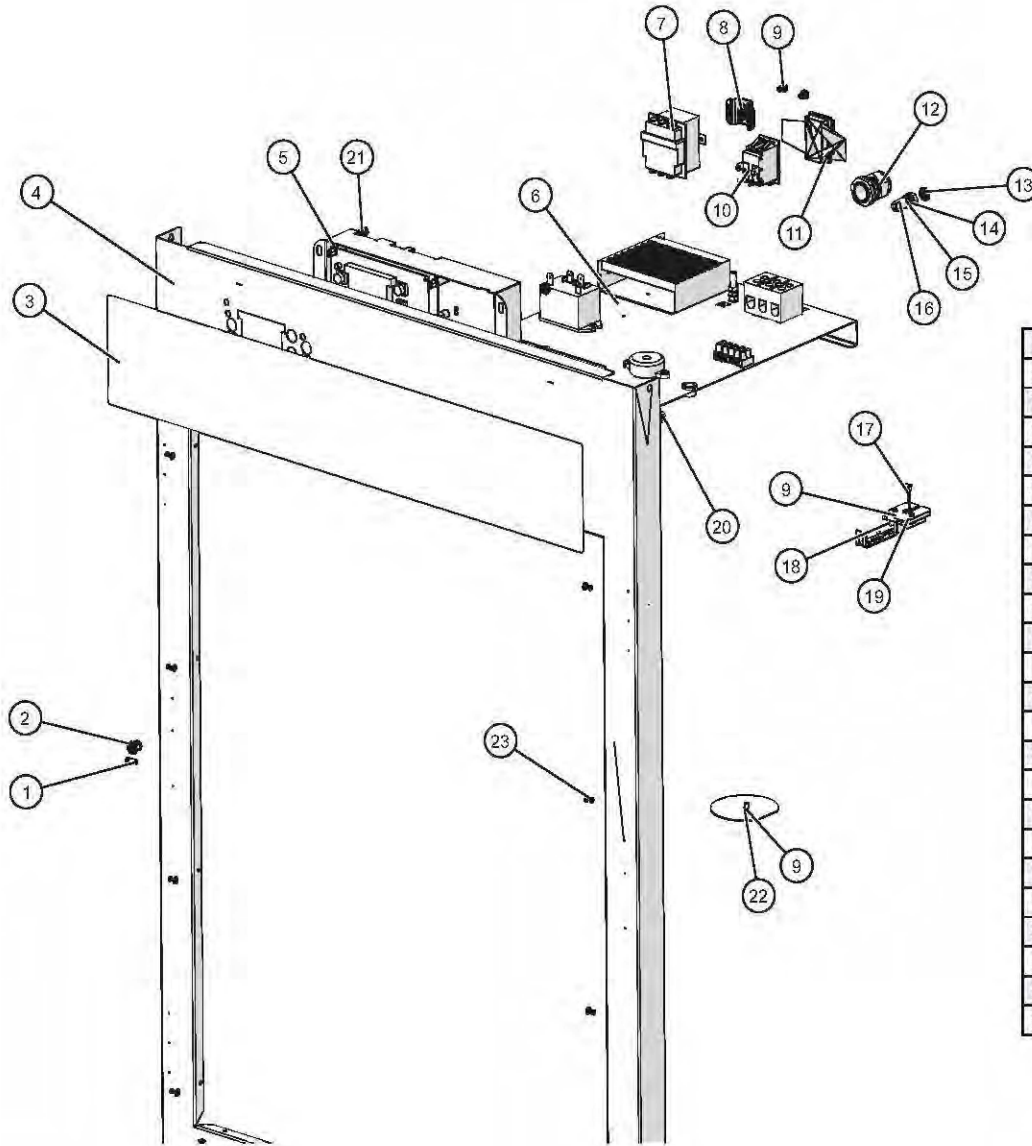

ID	Part No.	Description	Qty
1	SW-33559	SWITCH, REED, SPST	1
2	BU-3419	3/8" BLACK HOLE BUSHING	1
3	PE-28366	1200-S, ELEC, OVERLAY	1
4	5012732	1200-S ELEC FRONT TRIM STUD WELD	1
5	CC-34322	ELECTRONIC WARMER CONTROL	1
6	5012606	1000-S ELEC 230V, ELEC CHASSIS	1
7	TT-33476	THERMOSTAT, 300F HI-LIMIT	1
8	1003936	HI-LIMIT PROTECTION COVER	1
9	SC-22271	SCREW, M4x0.7X6MM PAN	5
10	SW-34769	SWITCH,ROCKER,125-277V,20A	1
11	CV-38297	COVER, IPX RATED, SW-34769	1
12	BU-3964	BUSHING,STRAIGHT,STRAIN RELIEF	1
13	WS-22297	WASHER, FLAT, M6, 18-8 SST	2
14	SC-22924	HHCS, M6 X 20, W/NO MARKING	1
15	WS-22302	WASHER, SPLIT LOCK, M6, 18-8 SST	2
16	NU-22770	NUT, THREADED INSERT, M6	1
17	SN-38110	SENSOR, 100 OHM, 110" WIRE,	1
18	1493	GUARD SENSOR,W/MW	1
19	BK-29605	BLOCK, SENSOR, ELEC. CONTROL	1
20	NU-2296	NUT, HEX #8-32	2
21	NU-26526	NUT, #8-32 UNC KEPS ZP	4
22	1006871	NON-PRODUCT PROBE SEAL	1
23	RI-2100	RIVET,BLIND,#44,STNLS	16

1200-S Bonnet Package "J", 230V 1850W Electronic

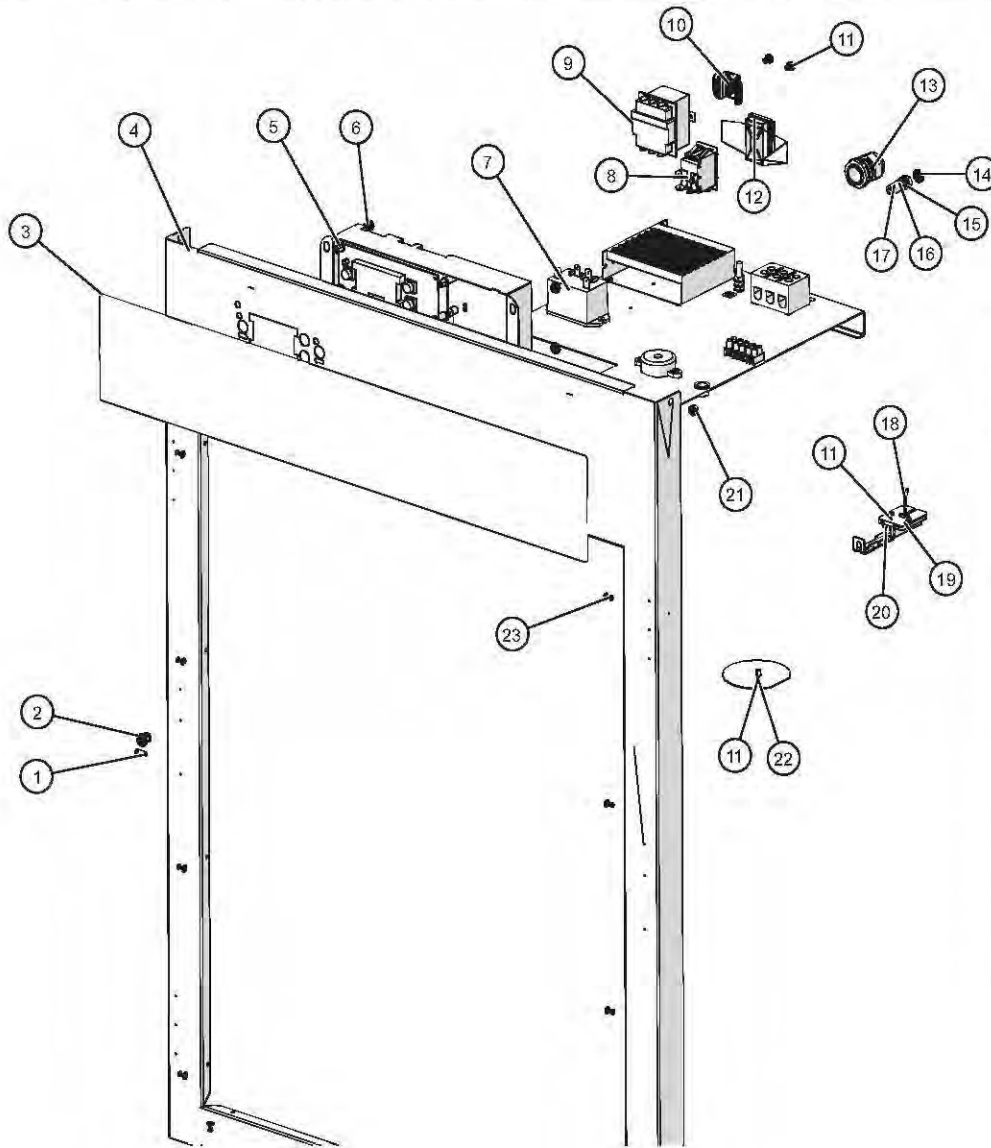

ID	Part No.	Description	Qty
1	SW-33559	SWITCH, REED, SPST	1
2	BU-3419	3/8" BLACK HOLE BUSHING	1
3	PE-28366	1200-S, ELEC. OVERLAY	1
4	5012732	1200-S ELEC FRONT TRIM STUD WELD	1
5	CC-34322	ELECTRONIC WARMER CONTROL	1
6	NU-26526	NUT, #8-32 UNC KEPS ZP	4
7	5012606	1000-S ELEC 230V, ELEC CHASSIS	1
8	SW-34769	SWITCH,ROCKER,125-277V,20A	1
9	TT-33476	THERMOSTAT, 300F HI-LIMIT	1
10	1003936	HI-LIMIT PROTECTION COVER	1
11	SC-22271	SCREW,M4x0.7X6MM PAN	5
12	CV-38297	COVER, IPX RATED, SW-34769	1
13	BU-3964	BUSHING,STRAIGHT,STRAIN RELIEF	1
14	WS-22297	WASHER, FLAT, M6, 18-8 SST	2
15	SC-22924	HHCS, M6 X 20, W/NO MARKING	1
16	WS-22302	WASHER, SPLIT LOCK, M6, 18-8 SST	2
17	NU-22770	NUT, THREADED INSERT, M6	1
18	SN-38110	SENSOR, 100 OHM, 110" WIRE,	1
19	BK-29605	BLOCK, SENSOR, ELEC. CONTROL	1
20	1493	GUARD SENSOR,W/MW	1
21	NU-2296	NUT, HEX #8-32	2
22	1006871	NON-PRODUCT PROBE SEAL	1
23	RI-2100	RIVET,BLIND,#44,STNLS	16

1200-S Bonnet Package "K", 120V Electronic w/Timer

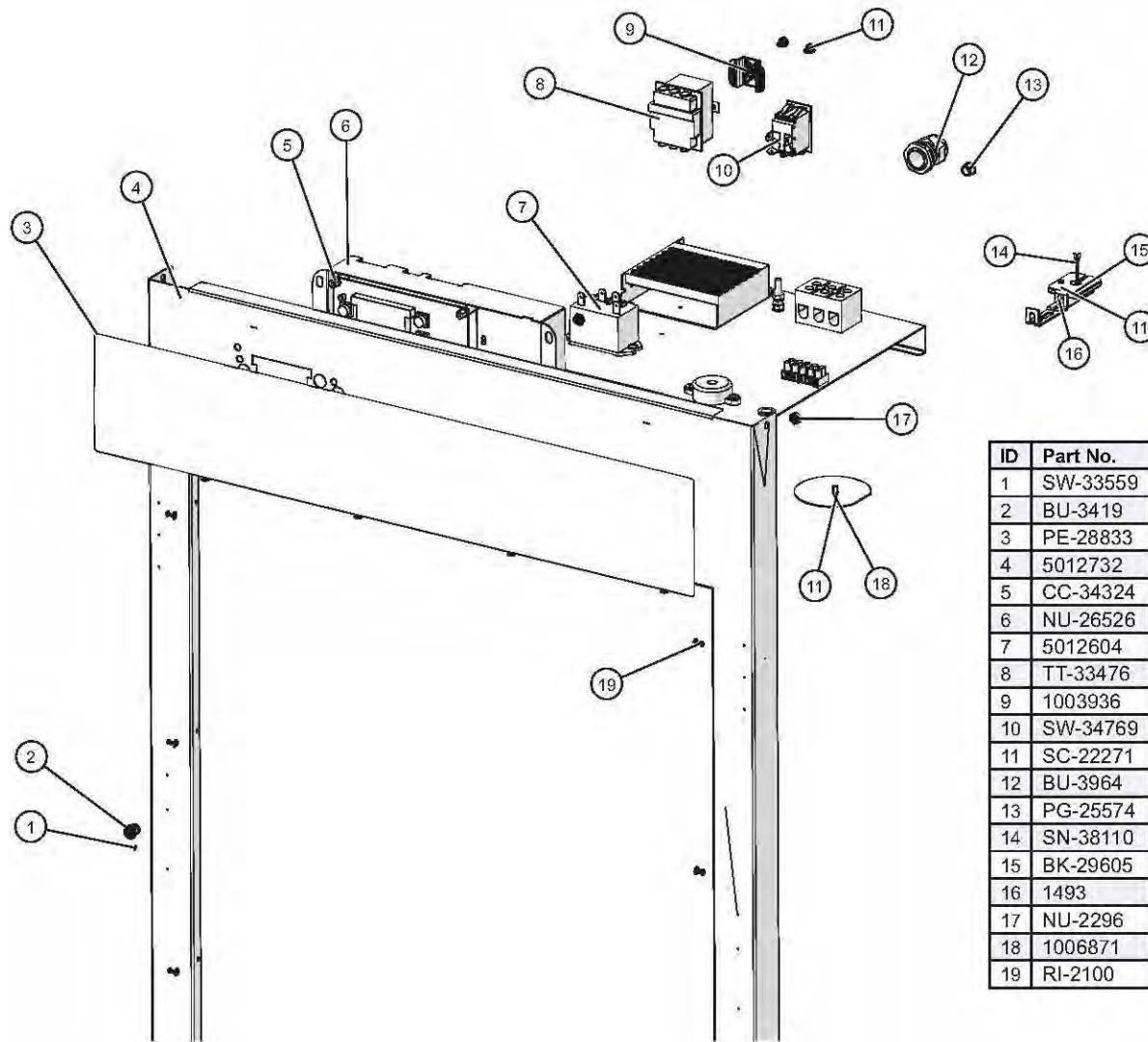

ID	Part No.	Description	Qty
1	SW-33559	SWITCH, REED, SPST	1
2	BU-3419	3/8" BLACK HOLE BUSHING	1
3	PE-28833	1200-S, ELEC, W/TIMER OVERLAY	1
4	5012732	1200-S ELEC FRONT TRIM STUD WELD	1
5	CC-34324	ELEC WARMER CONTROL W/ TIMER	1
6	NU-26526	NUT, #8-32 UNC KEPS ZP	4
7	5012604	1000-S ELEC 120V, ELEC CHASSIS	1
8	TT-33476	THERMOSTAT, 300F HI-LIMIT	1
9	1003936	HI-LIMIT PROTECTION COVER	1
10	SW-34769	SWITCH,ROCKER,125-277V,20A	1
11	SC-22271	SCREW	5
12	BU-3964	BUSHING,STRAIGHT,STRAIN RELIEF	1
13	PG-25574	3/8" HOLE PLUG	1
14	SN-38110	SENSOR, 100 OHM, 110" WIRE,	1
15	BK-29605	BLOCK, SENSOR, ELEC. CONTROL	1
16	1493	GUARD SENSOR,W/MW	1
17	NU-2296	NUT, HEX #8-32	2
18	1006871	NON-PRODUCT PROBE SEAL	1
19	RI-2100	RIVET,BLIND,#44,STNLS	16

1200-S Bonnet Package "N", 230V Electronic w/Timer

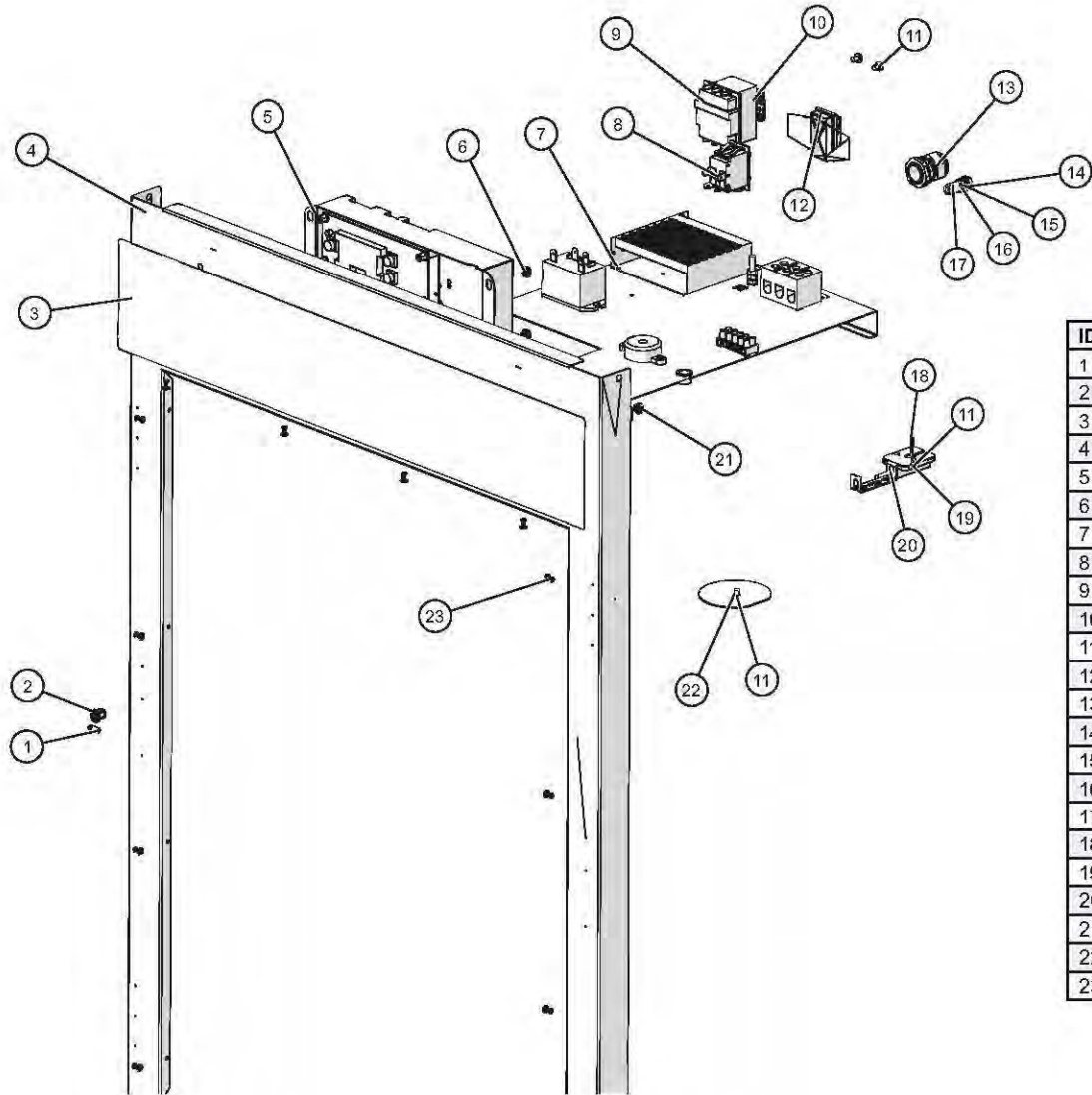

ID	Part No.	Description	Qty
1	SW-33559	SWITCH, REED, SPST	1
2	BU-3419	3/8" BLACK HOLE BUSHING	1
3	PE-28833	1200-S, ELEC, W/TIMER OVERLAY	1
4	5012732	1200-S ELEC FRONT TRIM ASSY	1
5	CC-34324	ELEC WARMER CONTROL W/ TIMER	1
6	NU-26526	NUT, #8-32 UNC KEPS ZP	4
7	5012606	1000-S ELEC 230V, ELEC CHASSIS	1
8	SW-34769	SWITCH,ROCKER, 125-277V,20A	1
9	TT-33476	THERMOSTAT, 300F HI-LIMIT	1
10	1003936	HI-LIMIT PROTECTION COVER	1
11	SC-22271	SCREW,M4x0.7X6MM PAN	5
12	CV-38297	COVER, IPX RATED, SW-34769	1
13	BU-3964	BUSHING,STRAIGHT,STRAIN RELIEF	1
14	SC-22924	HHCS, M6 X 20, W/NO MARKING	1
15	WS-22297	WASHER, FLAT	2
16	WS-22302	WASHER, SPLIT LOCK	2
17	NU-22770	NUT, THREADED INSERT, M6	1
18	SN-38110	SENSOR, 100 OHM, 110" WIRE,	1
19	BK-29605	BLOCK, SENSOR, ELEC. CONTROL	1
20	1493	GUARD SENSOR,W/MW	1
21	NU-2296	NUT, HEX #8-32	2
22	1006871	NON-PRODUCT PROBE SEAL	1
23	RI-2100	RIVET,BLIND,#44,STNLS	16

1200-S Bonnet Package "O", 230V Elec w/Timer, 1850W

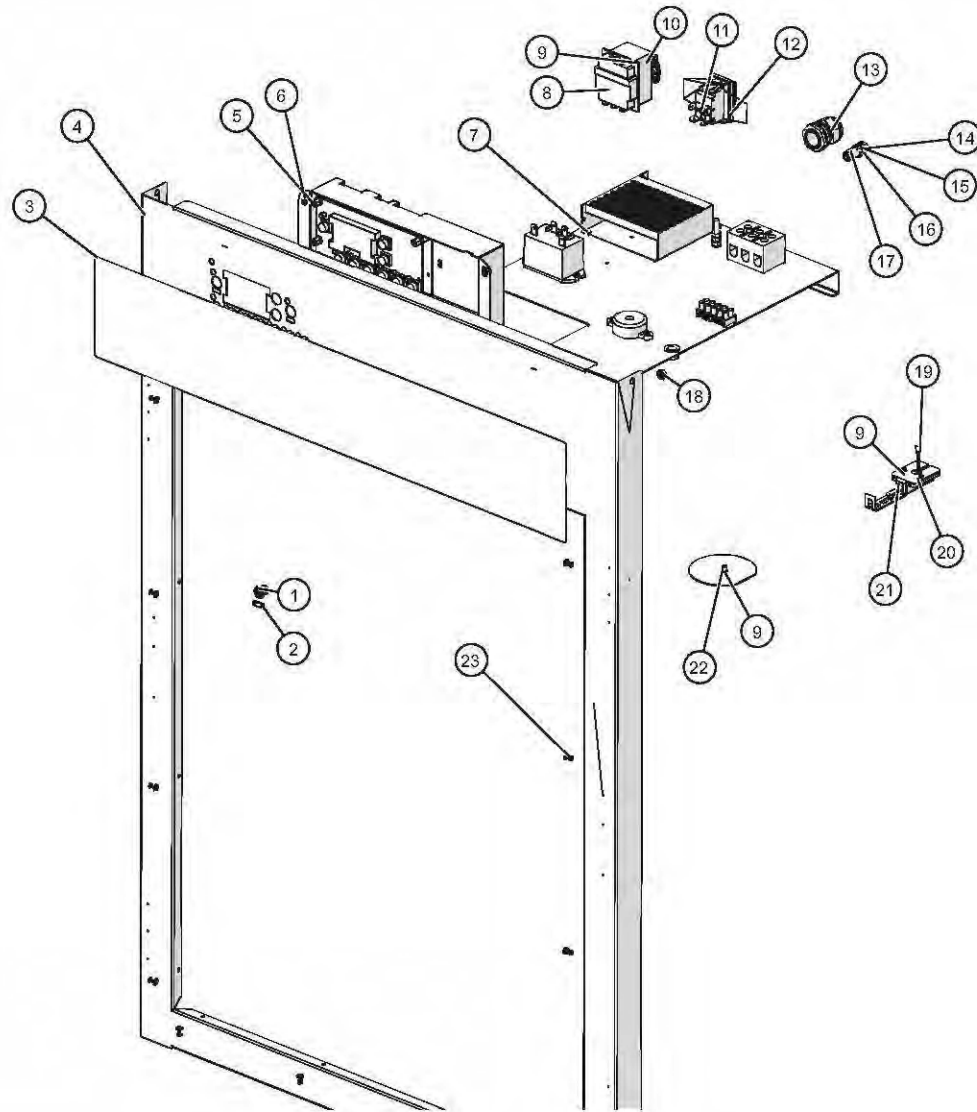

ID	Part No.	Description	Qty
1	BU-3419	3/8" BLACK HOLE BUSHING	1
2	SW-33559	SWITCH, REED, SPST	1
3	PE-28833	1200-S, ELEC, W/TIMER OVERLAY	1
4	5012732	1200-S ELEC FRONT TRIM ASSY	1
5	CC-34324	ELEC WARMER CONTROL W/ TIMER	1
6	NU-26526	NUT, #8-32 UNC KEPS ZP	4
7	5012606	1000-S ELEC 230V, ELEC CHASSIS	1
8	TT-33476	THERMOSTAT, 300F HI-LIMIT	1
9	SC-22271	SCREW, M4x0.7X6MM PAN	5
10	1003936	HI-LIMIT PROTECTION COVER	1
11	SW-34769	SWITCH, ROCKER, 125-277V, 20A	1
12	CV-38297	COVER, IPX RATED, SW-34769	1
13	BU-3964	BUSHING, STRAIGHT, STRAIN RELIEF	1
14	WS-22302	WASHER, SPLIT LOCK	2
15	WS-22297	WASHER, FLAT	2
16	SC-22924	HHCS, M6 X 20, W/NO MARKING	1
17	NU-22770	NUT, THREADED INSERT, M6	1
18	NU-2296	NUT, HEX #8-32	2
19	SN-38110	SENSOR, 100 OHM, 110" WIRE,	1
20	BK-29605	BLOCK, SENSOR, ELEC. CONTROL	1
21	1493	GUARD SENSOR, W/MW	1
22	1006871	NON-PRODUCT PROBE SEAL	1
23	RI-2100	RIVET, BLIND, #44, STNLS	16

1200-S Bonnet Package "S", 230V Electronic w/Probe

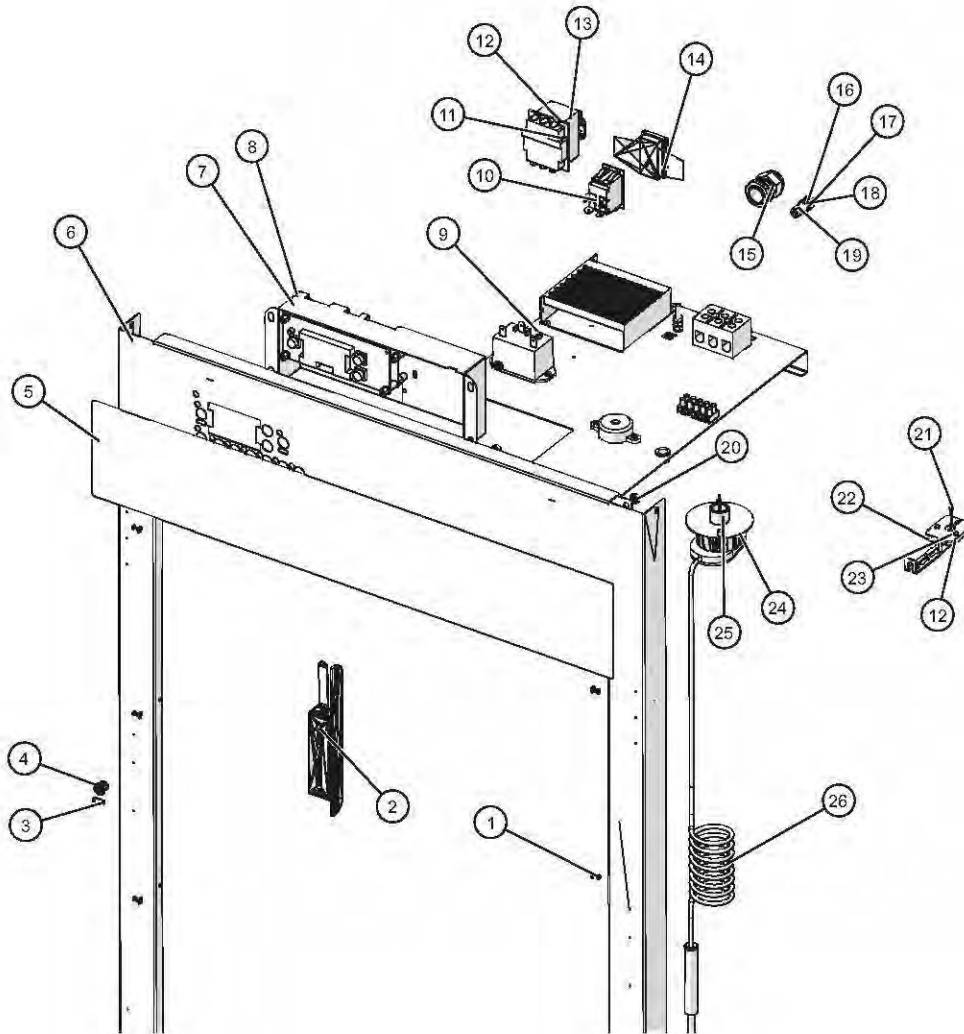

ID	Part No.	Description	Qty
1	RI-2100	RIVET,BLIND,#44,STNLS	16
2	13239	PROBE HOLDER, TH/III	1
3	SW-33559	SWITCH, REED, SPST	1
4	BU-3419	3/8" BLACK HOLE BUSHING	1
5	PE-28366	1200-S, ELEC, OVERLAY	1
6	5012732	1200-S ELEC FRONT TRIM ASSY	1
7	5012946	SINGLE WARMER CONTROL	1
8	NU-26526	NUT, #8-32 UNC KEPS ZP	4
9	5012606	1000-S ELEC 230V, ELEC CHASSIS	1
10	SW-34769	SWITCH,ROCKER,125-277V,20A	1
11	TT-33476	THERMOSTAT, 300F HI-LIMIT	1
12	SC-22271	SCREW,M4x0.7X6MM PAN	8
13	1003936	HI-LIMIT PROTECTION COVER	1
14	CV-38297	COVER, IPX RATED, SW-34769	1
15	BU-3964	BUSHING,STRAIGHT,STRAIN RELIEF	1
16	WS-22297	WASHER, FLAT	2
17	SC-22924	HHCS, M6 X 20, W/NO MARKING	1
18	WS-22302	WASHER, SPLIT LOCK	2
19	NU-22770	NUT, THREADED INSERT, M6	1
20	NU-2296	NUT, HEX #8-32	2
21	SN-38110	SENSOR, 100 OHM, 110" WIRE,	1
22	1493	GUARD SENSOR, W/MW	1
23	BK-29605	BLOCK, SENSOR, ELEC. CONTROL	1
24	5009712	PROBE COVER WELDMENT	1
25	PR-34705	PROBE,RECEPTACLE,600MM WIRE	1
26	PR-36065	PROBE,QUICK CONNECT,PT100	1

1200-UP Bonnet Package "A", 120V Manual

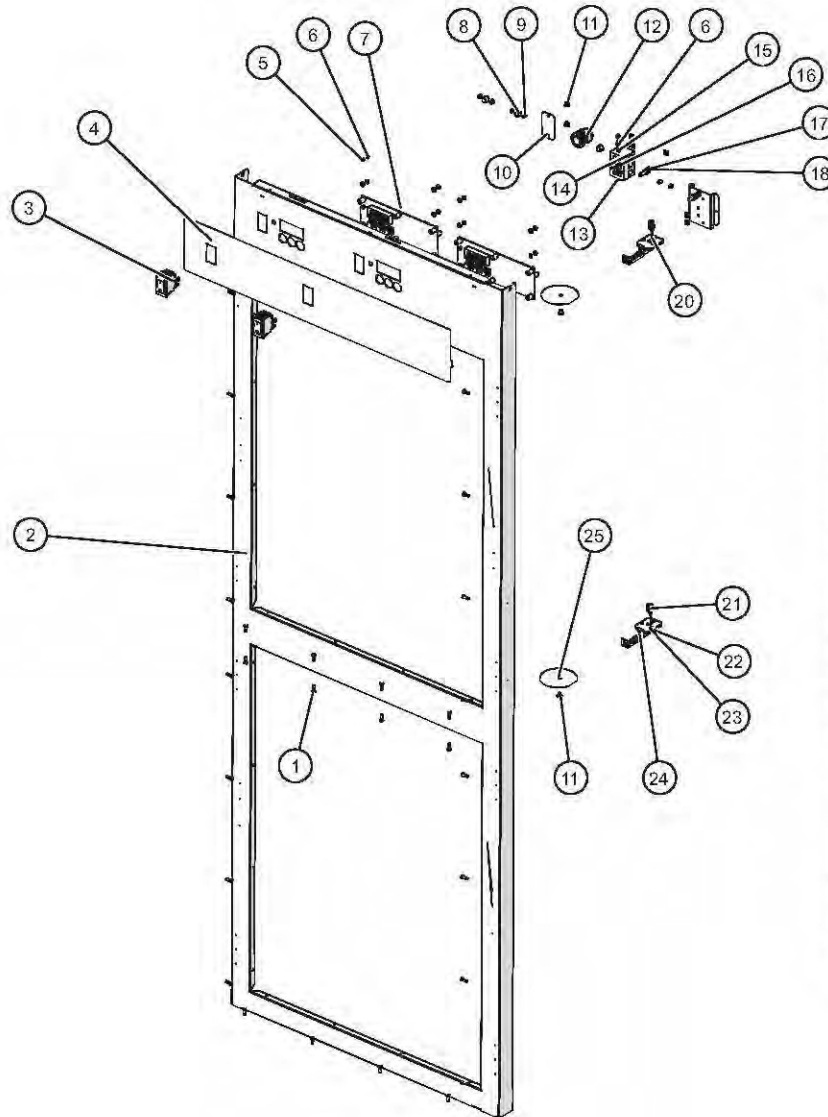

ID	Part No.	Description	Qty
1	RI-27108	RIVET, SEALED	32
2	5012345	1200-UP 2010 ELAN CONTROL	1
3	SW-34769	SWITCH,ROCKER,125-277V,20A	2
4	PE-29395	PANEL, OVERLAY, 1200-UP ELAN 2010	1
5	WS-23148	WASHER, 6-32, FLAT, NYL	8
6	NU-2361	NUT, 6-32 HEX, S/S	10
7	5012553	CONTROL ASSY,SIMPLE,DOUBLE	1
8	PG-25574	3/8" HOLE PLUG	3
9	PG-28439	PLUG, DOME,.187" HOLE	8
10	1011697	BREAKER SWITCH CUTOUT COVER	1
11	SC-2459	8-32 x 1/4" PHIL SCREW	4
12	BU-3964	BUSHING,STRAIGHT,STRAIN RELIEF	1
13	WS-23424	WASHER, FLAT, #8, 18-8 SST	2
14	SC-47136	SCREW,6-32X1-1/2" PAN	2
15	WS-22300	WASHER, SPLIT LOCK	2
16	BK-3019	T-BLOCK	1
17	NU-36234	NUT, M5, KEPS	3
18	SC-38128	SCREW,PAN PH, METRIC, M5	1
20	SN-47162	SENSOR, 1000 OHM, 40" WIRE,	1
21	SN-38111	SENSOR, 1000 OHM, 110" WIRE,	1
22	SC-22271	SCREWS,M4-0.7X6MM PHIL	4
23	BK-29605	BLOCK, SENSOR, ELEC. CONTROL	2
24	1493	GUARD SENSOR,W/MW	2
25	1006871	NON-PRODUCT PROBE SEAL	2

1200-UP Bonnet Package "B", 208V-240V Manual

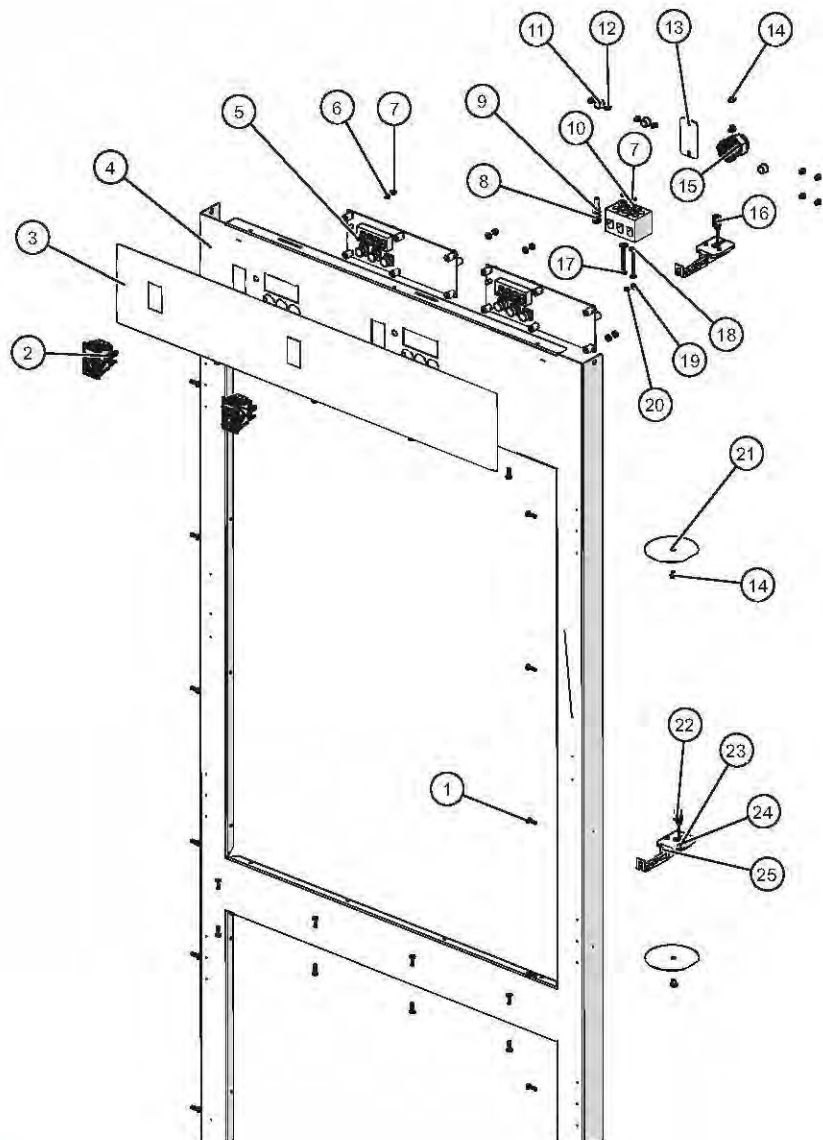

ID	Part No.	Description	Qty
1	RI-27108	RIVET, SEALED	32
2	SW-34769	SWITCH,ROCKER,125-277V,20A	2
3	PE-29395	PANEL, OVERLAY, 1200-UP ELAN 2010	1
4	5012345	1200-UP 2010 ELAN CONTROL	1
5	5012554	1000-UP MNL 208/240V, ELEC.	1
6	WS-23148	WASHER, 6-32, FLAT, NYL	7
7	NU-2361	NUT, 6-32 HEX, S/S	9
8	SC-38128	SCREW,PAN PH, METRIC, M5	1
9	NU-36234	NUT, M5, KEPS	3
10	WS-22300	WASHER, SPLIT LOCK	2
11	PG-25574	3/8" HOLE PLUG	3
12	PG-28439	PLUG, DOME, .187" HOLE	8
13	1011697	BREAKER SWITCH CUTOUT COVER	1
14	SC-2459	8-32 x 1/4" PHIL SCREW	4
15	BU-3964	BUSHING,STRAIGHT,STRAIN RELIEF	1
16	SN-47162	SENSOR, 1000 OHM, 40" WIRE,	1
17	SC-47136	SCREW,6-32X1-1/2" PAN	2
18	WS-23424	WASHER, FLAT, #8, 18-8 SST	2
19	NU-2361	NUT, 6-32 HEX, S/S	1
20	WS-23148	WASHER, 6-32, FLAT, NYL	1
21	1006871	NON-PRODUCT PROBE SEAL	2
22	SN-38111	SENSOR, 1000 OHM, 110" WIRE,	1
23	SC-22271	SCREWS,M4-0.7X6MM PHIL	4
24	BK-29605	BLOCK, SENSOR, ELEC. CONTROL	2
25	1493	GUARD SENSOR,W/MW	2

1200-UP Bonnet Package "C", 208V-240V 4000W Manual

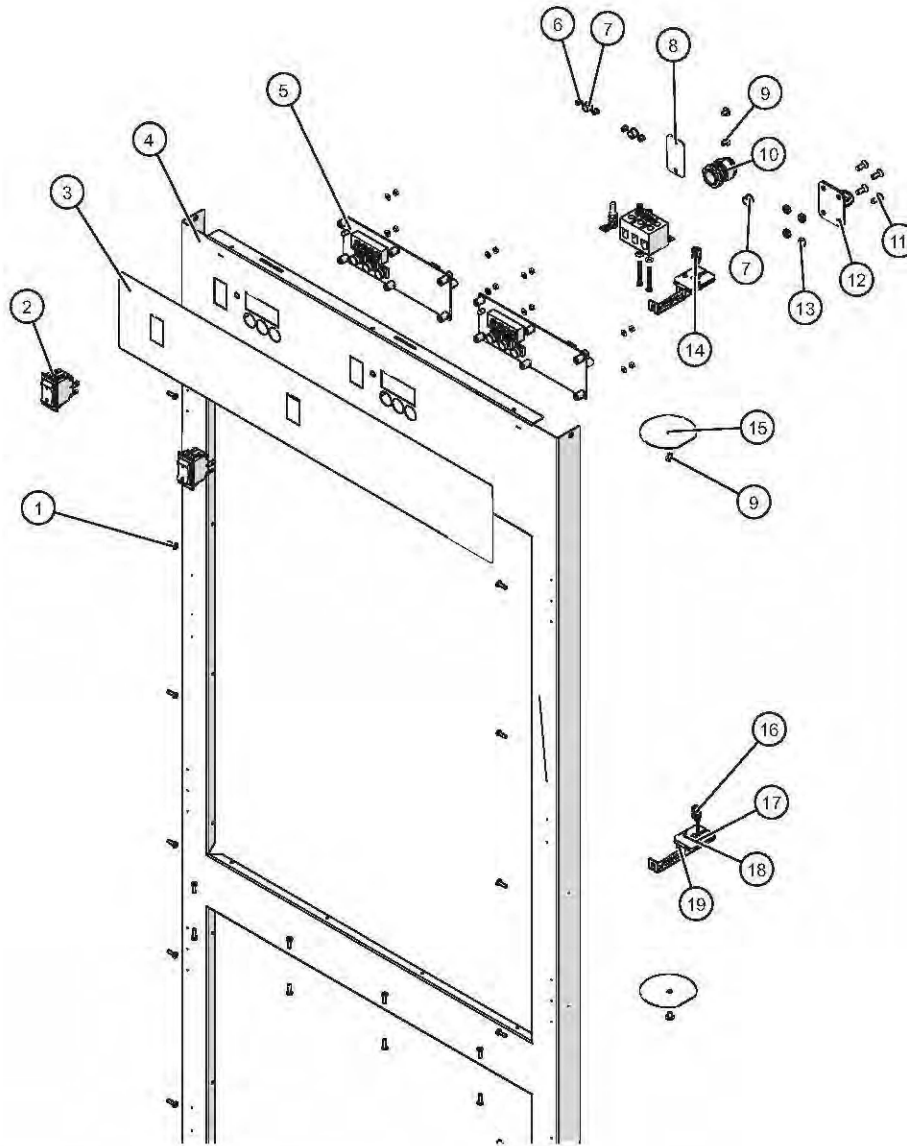

ID	Part No.	Description	Qty
1	RI-27108	RIVET, SEALED	32
2	SW-34769	SWITCH,ROCKER,125-277V,20A	2
3	PE-29395	PANEL, OVERLAY, 1200-UP ELAN 2010	1
4	5012345	1200-UP 2010 ELAN CONTROL	1
5	5013162	ELEC CHASSIS,1200-UP, 4000W	1
6	PG-28439	PLUG, DOME, .187" HOLE	4
7	PG-25574	3/8" HOLE PLUG	3
8	1011697	BREAKER SWITCH CUTOFF COVER	1
9	SC-2459	8-32 x 1/4" PHIL SCREW	4
10	BU-3964	BUSHING,STRAIGHT,STRAIN RELIEF	1
11	SC-23670	SCREW,10-32X1/2,NF PHIL,FLAT,	4
12	BT-26884	BRACKET, TETHER.	1
13	NU-2215	NUT,10-32 UNF HEX MS,18-8 SST	4
14	SN-47162	SENSOR, 1000 OHM, 40" WIRE,	1
15	1006871	NON-PRODUCT PROBE SEAL	2
16	SN-38111	SENSOR, 1000 OHM, 110" WIRE,	1
17	BK-29605	BLOCK, SENSOR, ELEC. CONTROL	2
18	SC-22271	SCREWS,M4-0.7X6MM PHIL	4
19	1493	GUARD SENSOR,W/MW	2

1200-UP Bonnet Package "D", 230V Manual

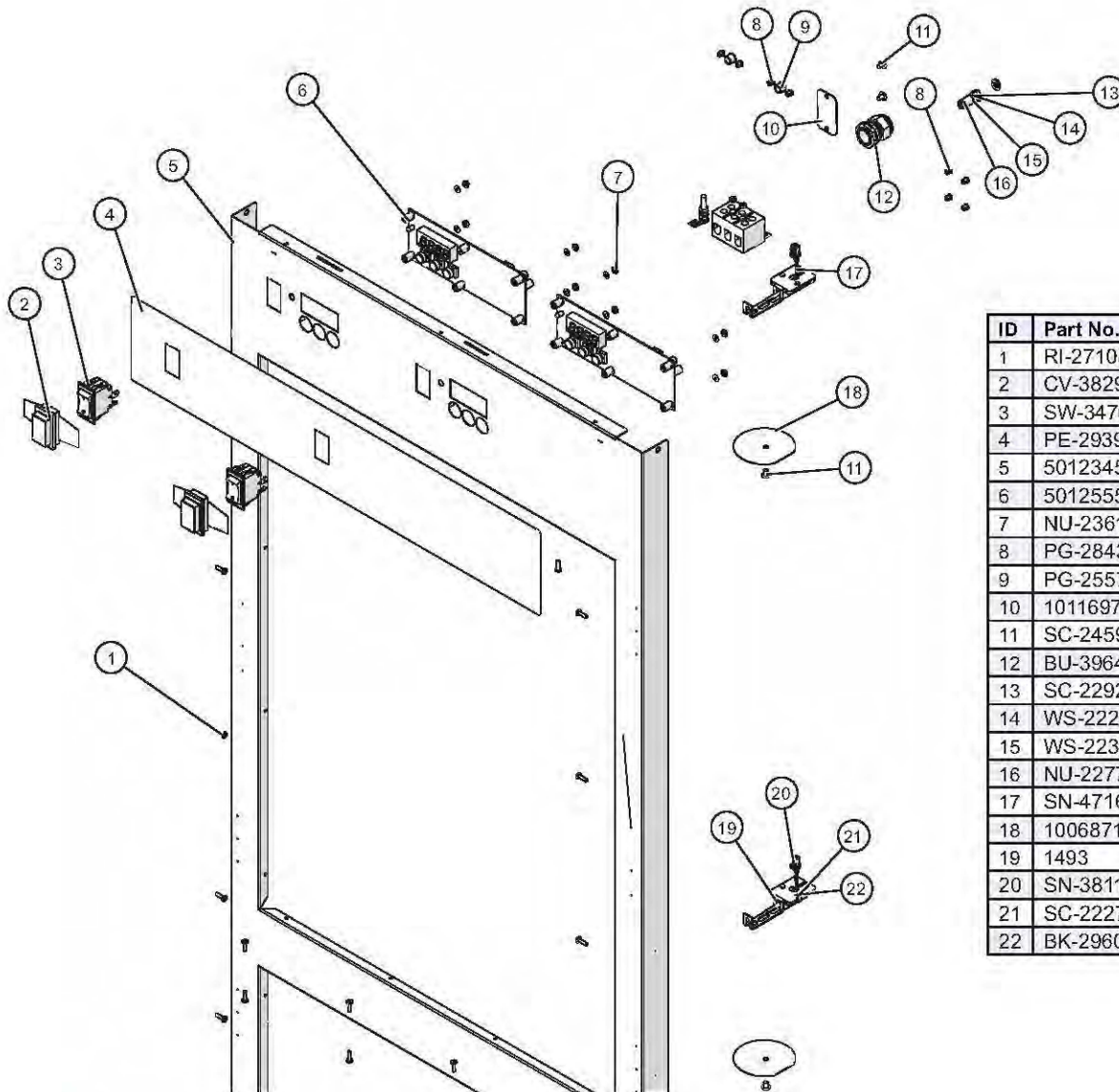

ID	Part No.	Description	Qty
1	RI-27108	RIVET, SEALED, 0.125"x0.45"	32
2	CV-38297	COVER, IPX RATED, SW-34769	2
3	SW-34769	SWITCH,ROCKER,125-277V,20A	2
4	PE-29395	PANEL, OVERLAY, 1200-UP ELAN 2010	1
5	5012345	1200-UP 2010 ELAN CONTROL	1
6	5012555	ELEC. CHASSIS, 1000/1200-UP, 230V	1
7	NU-2361	NUT, 6-32 HEX, S/S	10
8	PG-28439	PLUG, DOME, .187" HOLE	8
9	PG-25574	3/8" HOLE PLUG	2
10	1011697	BREAKER SWITCH CUTOUT COVER	1
11	SC-2459	8-32 x 1/4" PHIL SCREW	4
12	BU-3964	BUSHING, STRAIGHT, STRAIN RELIEF	1
13	SC-22924	HHCS, M6 X 20, W/NO MARKING	1
14	WS-22297	WASHER, FLAT M6, 18-8 SST	2
15	WS-22302	WASHER, SPLIT LOCK	2
16	NU-22770	NUT, THREADED INSERT, M6	1
17	SN-47162	SENSOR, 1000 OHM, 40" WIRE,	1
18	1006871	NON-PRODUCT PROBE SEAL	2
19	1493	GUARD SENSOR, W/MW	2
20	SN-38111	SENSOR, 1000 OHM, 110" WIRE,	1
21	SC-22271	SCREWS, M4-0.7X6MM PHIL	4
22	BK-29605	BLOCK, SENSOR, ELEC. CONTROL	2

1200-UP Bonnet Package "E", 230V 3700W Manual

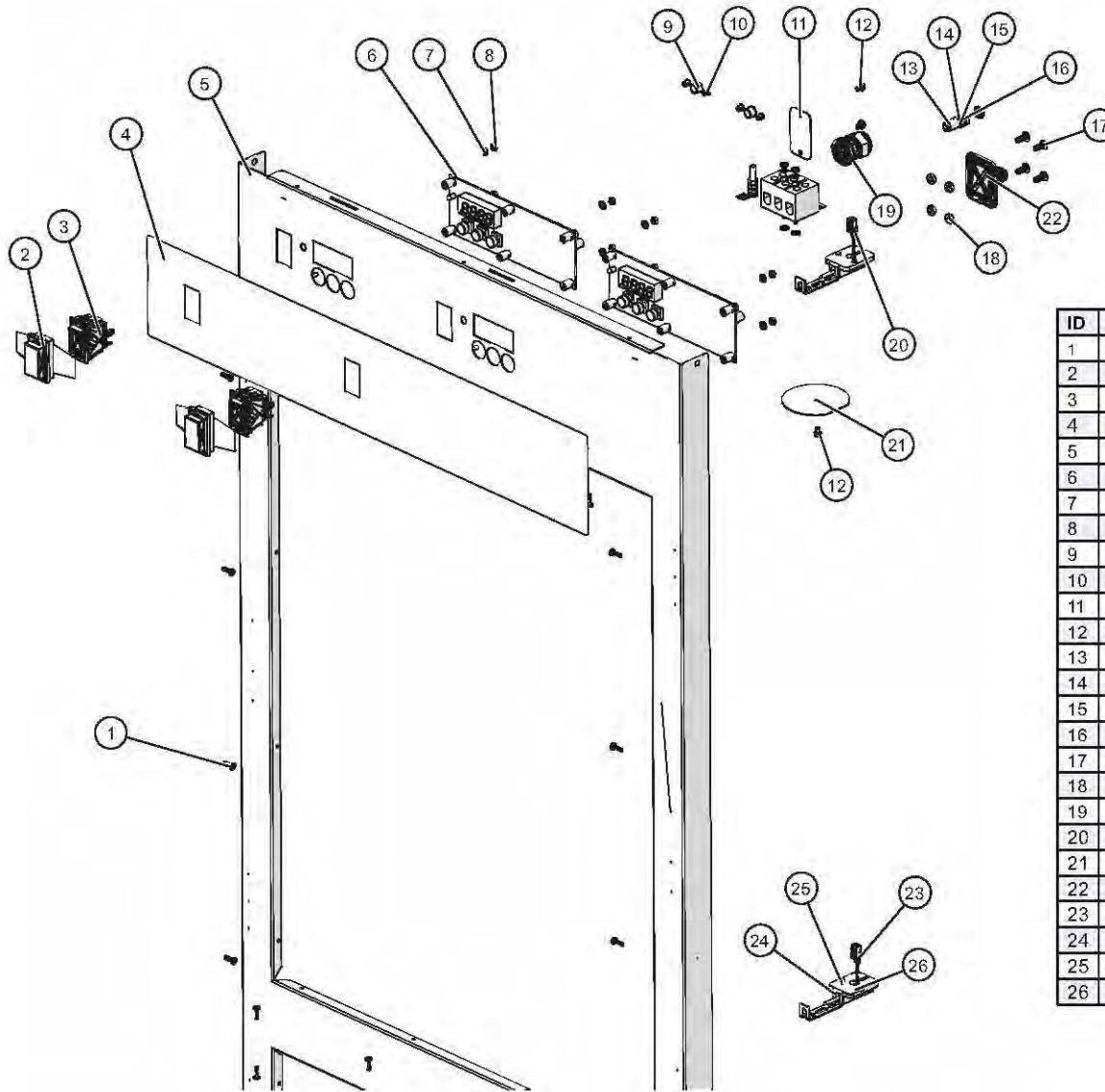

ID	Part No.	Description	Qty
1	RI-27108	RIVET, SEALED	32
2	CV-38297	COVER, IPX RATED, SW-34769	2
3	SW-34769	SWITCH,ROCKER,125-277V,20A	2
4	PE-29395	PANEL, OVERLAY, 1200-UP ELAN 2010	1
5	5012345	1200-UP 2010 ELAN CONTROL	1
6	5012555	ELEC. CHASSIS, 1000/1200-UP	1
7	WS-23148	WASHER, 6-32, FLAT, NYL	8
8	NU-2361	NUT, 6-32 HEX, S/S	10
9	PG-25574	3/8" HOLE PLUG	2
10	PG-28439	PLUG, DOME, .187" HOLE	4
11	1011697	BREAKER SWITCH CUTOFF COVER	1
12	SC-2459	8-32 x 1/4" PHIL SCREW	4
13	NU-22770	NUT, THREADED INSERT, M6	1
14	WS-22297	WASHER, FLAT	2
15	WS-22302	WASHER, SPLIT LOCK	2
16	SC-22924	HHCS, M6 X 20, W/NO MARKING	1
17	SC-23670	SCREW,10-32X1/2,NF PHIL,FLAT,	4
18	NU-2215	NUT,10-32 UNF HEX MS,18-8 SST	4
19	BU-3964	BUSHING,STRAIGHT,STRAIN RELIEF	1
20	SN-47162	SENSOR, 1000 OHM, 40" WIRE,	1
21	1006871	NON-PRODUCT PROBE SEAL	2
22	BT-26884	BRACKET, TETHER.	1
23	SN-38111	SENSOR, 1000 OHM, 110" WIRE,	1
24	1493	GUARD SENSOR,W/MW	2
25	SC-22271	SCREWS,M4-0.7X6MM PHIL	4
26	BK-29605	BLOCK, SENSOR, ELEC. CONTROL.	2

1200-UP Bonnet Package "F", 120V Electronic

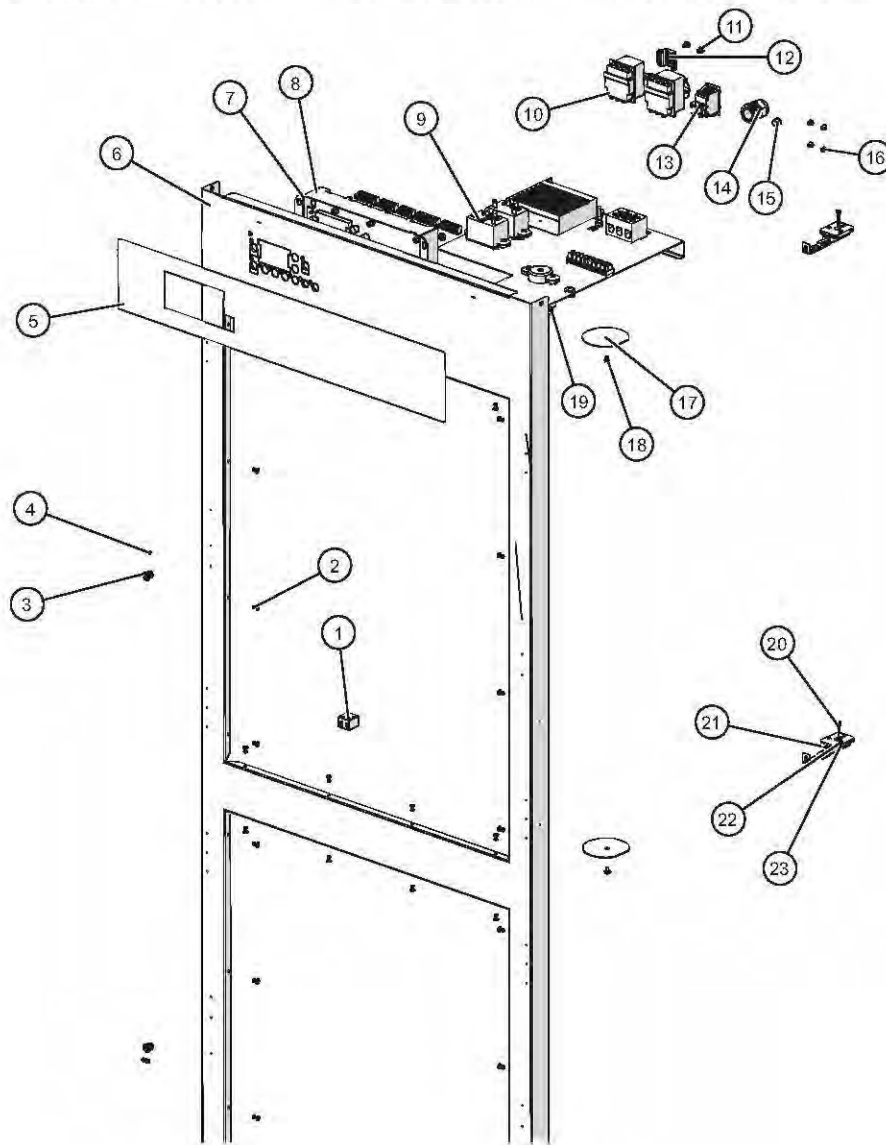

ID	Part No.	Description	Qty
1	BK-33546	BLOCK, 2 TERMINAL, PORCELAIN	1
2	RI-2100	RIVET,BLIND,#44,STNLS	32
3	BU-3419	3/8" BLACK HOLE BUSHING	2
4	SW-33559	SWITCH, REED, SPST	2
5	PE-27855	1200-UP, ELEC, OVERLAY	1
6	5012680	1200-UP ELEC FRONT TRIM ASSY	1
7	CC-34326	CONTROL W/O TIMERS	1
8	NU-26526	NUT, #8-32 UNC KEPS ZP	4
9	5012943	1200-UP ELEC 120V, ELEC. CH	1
10	TT-34600	THERMOSTAT, 300F HI-LIMIT	2
11	SC-22271	SCREWS,M4-0.7X6MM PHIL	4
12	1003936	HI-LIMIT PROTECTION COVER	2
13	SW-34769	SWITCH,ROCKER,125-277V,20A	1
14	BU-3964	BUSHING,STRAIGHT,STRAIN RELIEF	1
15	PG-25574	3/8" HOLE PLUG	1
16	PG-28439	PLUG, DOME, .187" HOLE	4
17	1006871	NON-PRODUCT PROBE SEAL	2
18	SC-2459	8-32 x 1/4" PHIL SCREW	2
19	NU-2296	NUT, HEX #8-32	2
20	SN-38110	SENSOR, 100 OHM, 110" WIRE,	2
21	1493	GUARD SENSOR,W/MW	2
22	BK-29605	BLOCK, SENSOR, ELEC. CONTROL	2
23	SC-22271	SCREW,M4x0.7X6MM PAN	4

1200-UP Bonnet Package "G", 208V-240V Electronic

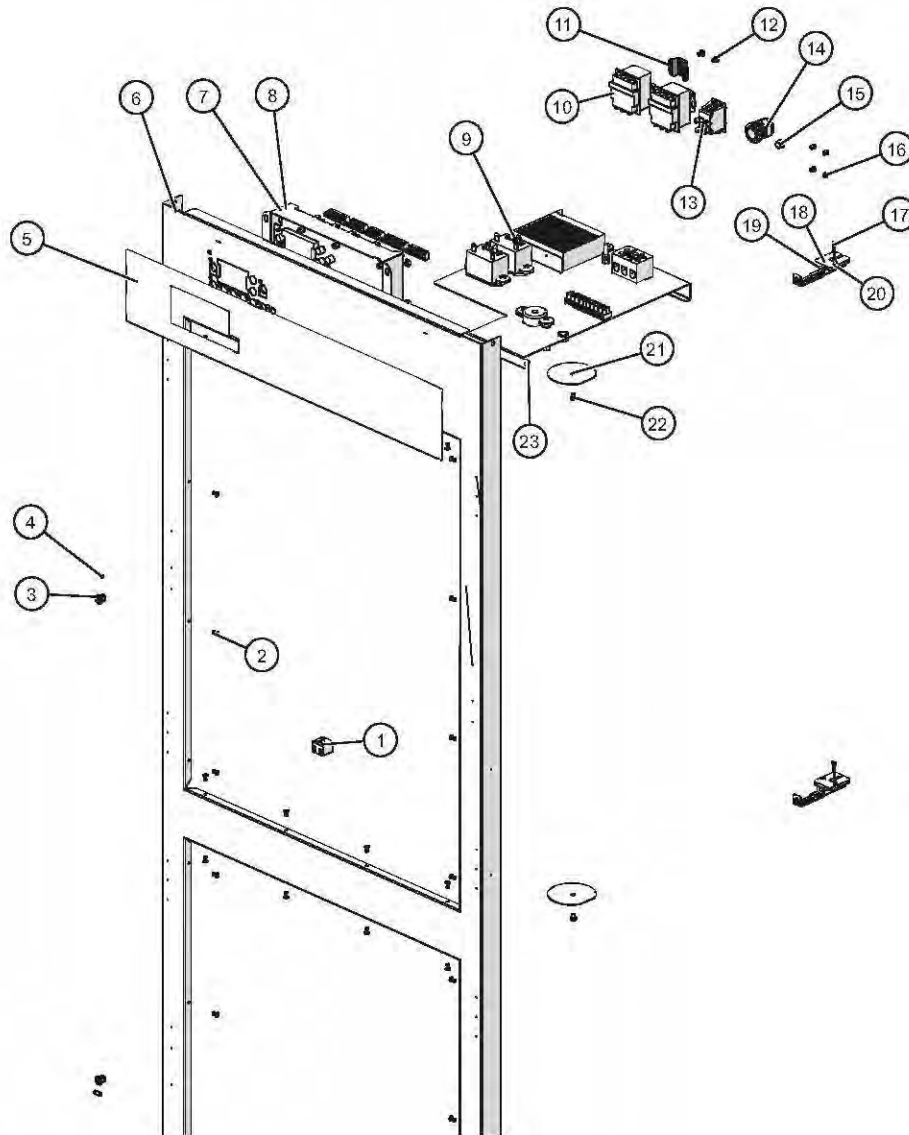

ID	Part No.	Description	Qty
1	BK-33546	BLOCK, 2 TERMINAL, PORCELAIN	1
2	RI-2100	RIVET,BLIND,#44,STNLS	32
3	BU-3419	3/8" BLACK HOLE BUSHING	2
4	SW-33559	SWITCH, REED, SPST	2
5	PE-27855	1200-UP, ELEC, OVERLAY	1
6	5012660	1200-UP ELEC FRONT TRIM ASSY	1
7	CC-34326	CONTROL W/O TIMERS	1
8	NU-26526	NUT, #8-32 UNC KEPS ZP	4
9	5012941	1200-UP ELEC 208/240V, ELEC	1
10	TT-34600	THERMOSTAT, 300F HI-LIMIT	2
11	1003936	HI-LIMIT PROTECTION COVER	2
12	SC-22271	SCREWS,M4-0.7X6MM PHIL	4
13	SW-34769	SWITCH,ROCKER,125-277V,20A	1
14	BU-3964	BUSHING,STRAIGHT,STRAIN RELIEF	1
15	PG-25574	3/8" HOLE PLUG	1
16	PG-28439	PLUG, DOME, .187" HOLE	4
17	SN-38110	SENSOR, 100 OHM, 110" WIRE,	2
18	SC-22271	SCREW,M4x0.7X6MM PAN	4
19	1493	GUARD SENSOR,W/MW	2
20	BK-29605	BLOCK, SENSOR, ELEC. CONTROL	2
21	1006871	NON-PRODUCT PROBE SEAL	2
22	SC-2459	8-32 x 1/4" PHIL SCREW	2
23	NU-2296	NUT, HEX #8-32	2

1200-UP Bonnet Package "H", 208V-240V 4000W Electronic

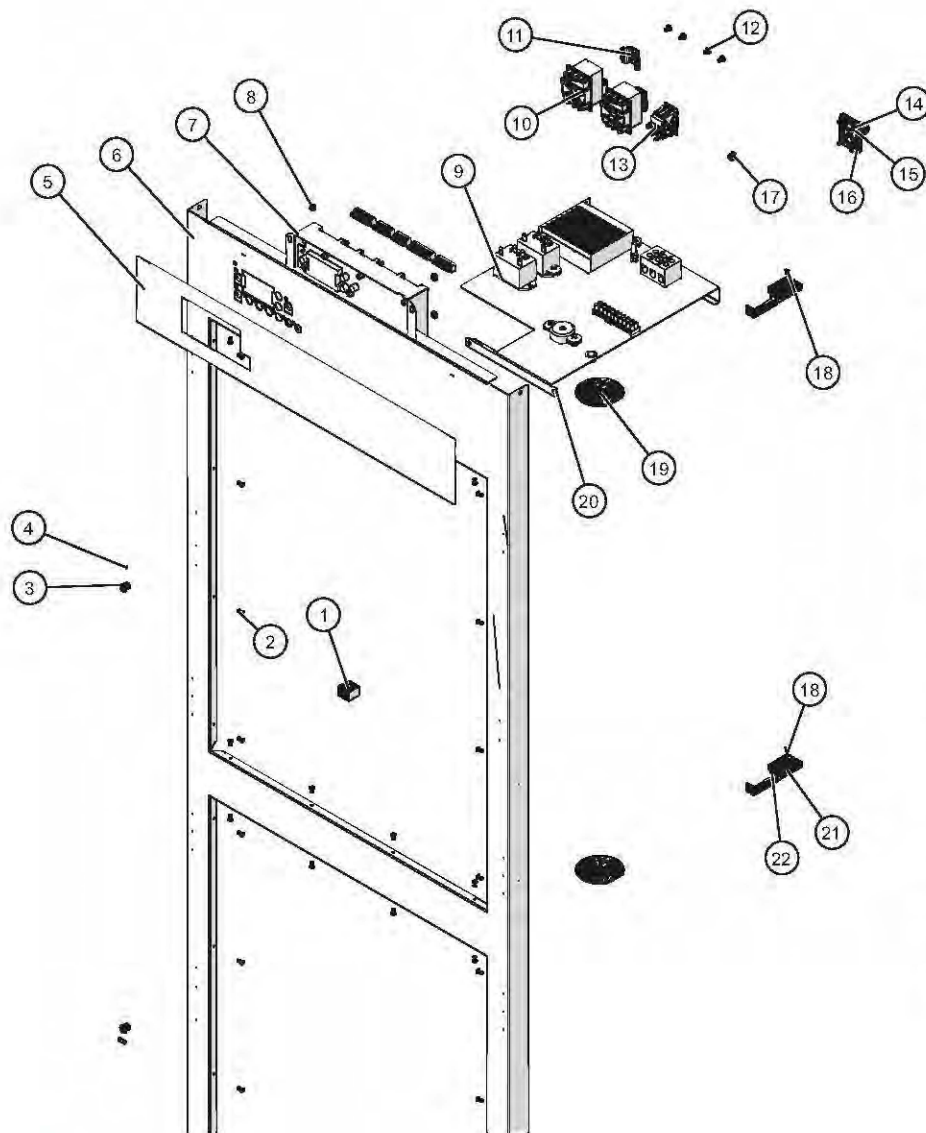

ID	Part No.	Description	Qty
1	BK-33546	BLOCK, 2 TERMINAL, PORCELAIN	1
2	RI-2100	RIVET,BLIND,#44,STNLS	32
3	BU-3419	3/8" BLACK HOLE BUSHING	2
4	SW-33559	SWITCH, REED, SPST	2
5	PE-27855	1200-UP, ELEC, OVERLAY	1
6	5012660	1200-UP ELEC FRONT TRIM ASSY	1
7	CC-34326	CONTROL W/O TIMERS	1
8	NU-26526	NUT, #8-32 UNC KEPS ZP	4
9	5012665	1200-UP ELEC 208/240V 4000W,	1
10	TT-34600	THERMOSTAT, 300F HI-LIMIT	2
11	1003936	HI-LIMIT PROTECTION COVER	2
12	SC-22271	SCREWS,M4-0.7X6MM PHIL	4
13	SW-34769	SWITCH,ROCKER,125-277V,20A	1
14	NU-2215	NUT,10-32 UNF HEX MS,18-8 SST	4
15	BT-26884	BRACKET, TETHER.	1
16	SC-23670	SCREW,10-32X1/2,NF PHIL,FLAT,	4
17	PG-25574	3/8" HOLE PLUG	1
18	SN-38110	SENSOR, 100 OHM, 110" WIRE,	2
19	1006871	NON-PRODUCT PROBE SEAL	2
20	NU-2296	NUT, HEX #8-32	2
21	BK-29605	BLOCK, SENSOR, ELEC. CONTROL	2
22	1493	GUARD SENSOR,W/MW	2

1200-UP Bonnet Package "I", 230V Electronic

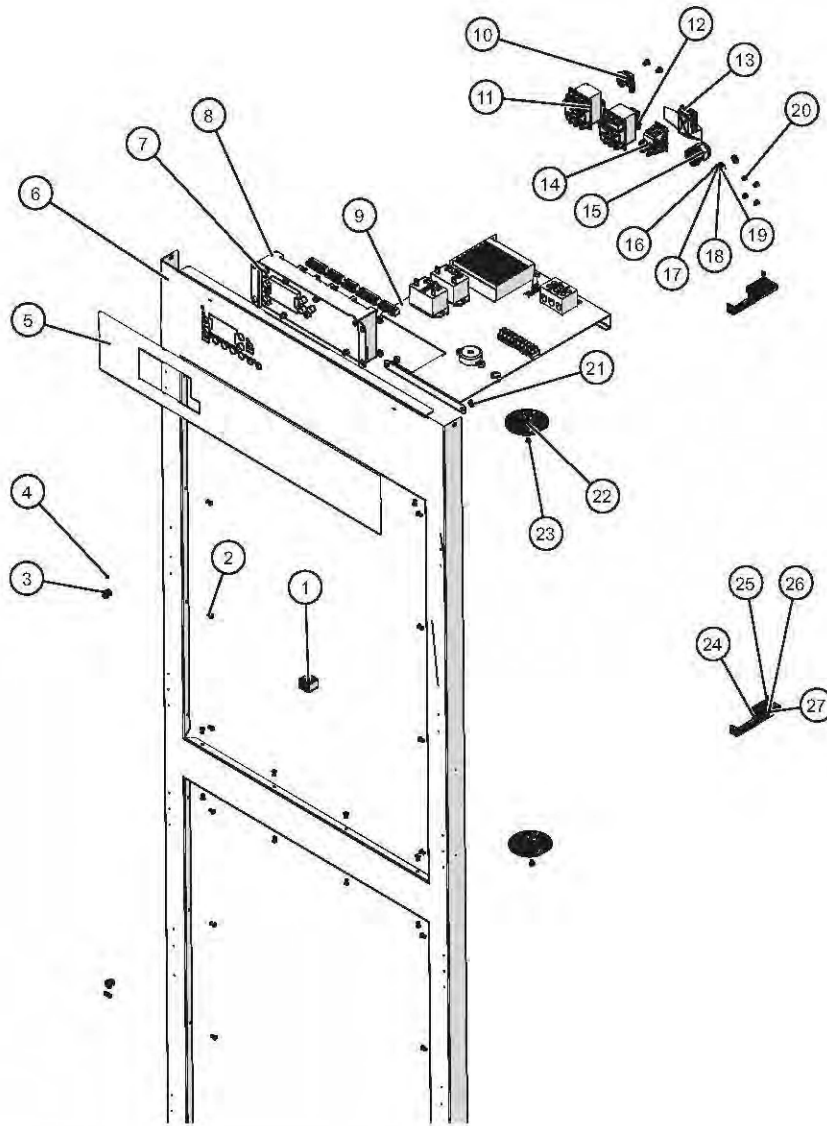

ID	Part No.	Description	Qty
1	BK-33546	BLOCK, 2 TERMINAL, PORCELAIN	1
2	RI-2100	RIVET,BLIND,#44,STNLS	32
3	BU-3419	3/8" BLACK HOLE BUSHING	2
4	SW-33559	SWITCH, REED, SPST	2
5	PE-27855	1200-UP, ELEC, OVERLAY	1
6	5012660	1200-UP ELEC FRONT TRIM ASSY	1
7	CC-34326	CONTROL W/O TIMERS	1
8	NU-26526	NUT, #8-32 UNC KEPS ZP	4
9	5012942	1200-UP ELEC CHASSIS 230V	1
10	1003936	HI-LIMIT PROTECTION COVER	2
11	TT-34600	THERMOSTAT, 300F HI-LIMIT	2
12	SC-22271	SCREW,M4x0.7X6MM PAN	4
13	CV-38297	COVER, IPX RATED, SW-34769	1
14	SW-34769	SWITCH,ROCKER,125-277V,20A	1
15	BU-3964	BUSHING,STRAIGHT,STRAIN RELIEF	1
16	NU-22770	NUT, THREADED INSERT, M6	1
17	WS-22302	WASHER, SPLIT LOCK	2
18	WS-22297	WASHER, FLAT	2
19	SC-22924	HHCS, M6 X 20, W/NO MARKING	1
20	PG-28439	PLUG, DOME,.187" HOLE	4
21	NU-2296	NUT, HEX #8-32	2
22	1006871	NON-PRODUCT PROBE SEAL	2
23	SC-2459	8-32 x 1/4" PHIL SCREW	2
24	1493	GUARD SENSOR,W/MW	2
25	SN-38110	SENSOR, 100 OHM, 110" WIRE,	2
26	SC-22271	SCREW,M4x0.7X6MM PAN	4
27	BK-29605	BLOCK, SENSOR, ELEC. CONTROL	2

1200-UP Bonnet Package "J", 230V 3700W Electronic

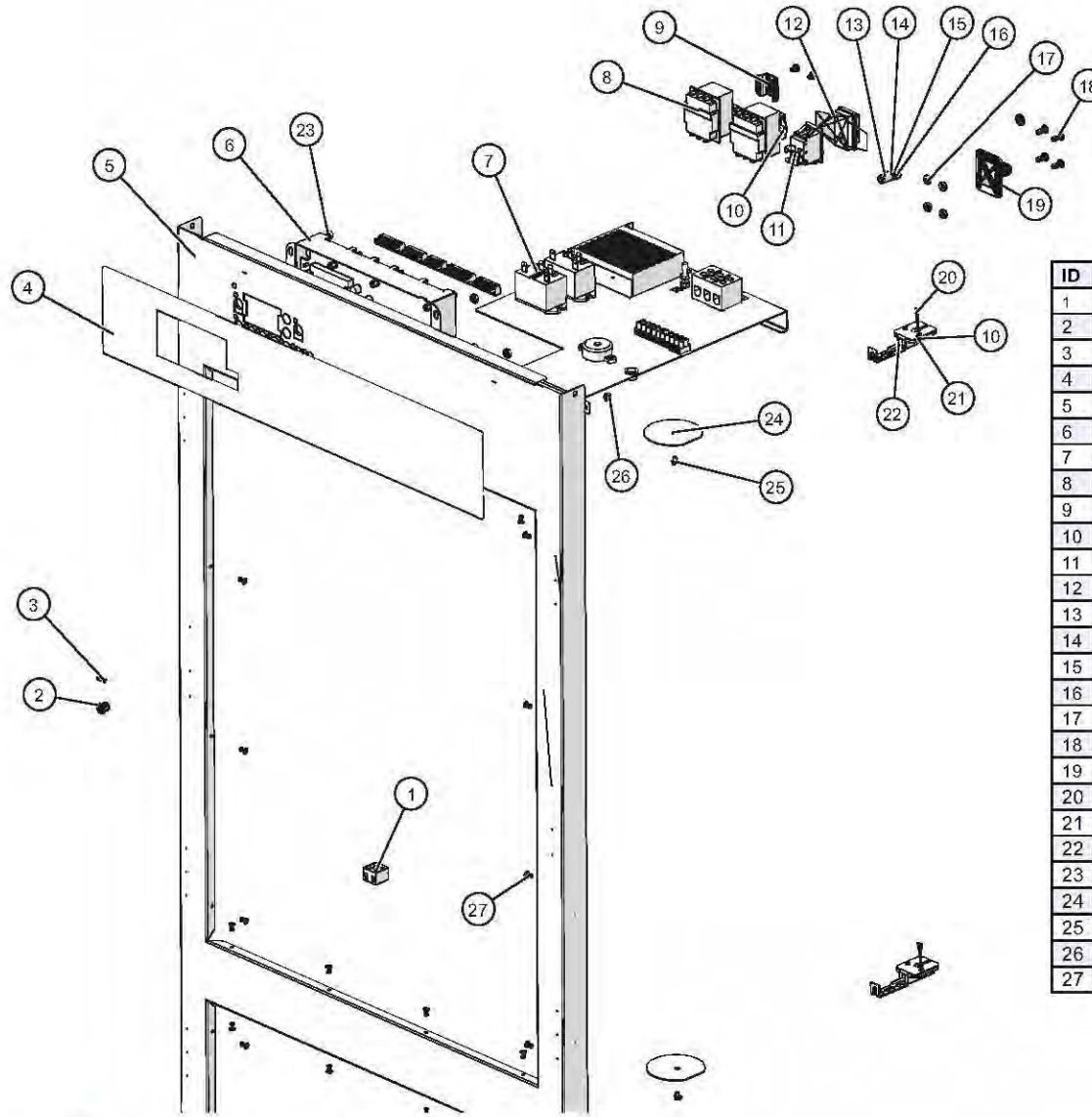

ID	Part No.	Description	Qty
1	BK-33546	BLOCK, 2 TERMINAL, PORCELAIN	1
2	BU-3419	3/8" BLACK HOLE BUSHING	2
3	SW-33559	SWITCH, REED, SPST	2
4	PE-27855	1200-UP, ELEC, OVERLAY	1
5	5012660	1200-UP ELEC FRONT TRIM STUD WELD	1
6	CC-34326	CONTROL W/O TIMERS	1
7	5012664	1200-UP ELEC 230V 3700W, ELEC	1
8	TT-34600	THERMOSTAT, 300F HI-LIMIT	2
9	1003936	HI-LIMIT PROTECTION COVER	2
10	SC-22271	SCREW,M4x0.7X6MM PAN	8
11	SW-34769	SWITCH,ROCKER,125-277V,20A	1
12	CV-38297	COVER, IPX RATED, SW-34769	1
13	NU-22770	NUT, THREADED INSERT, M6	1
14	WS-22302	WASHER, SPLIT LOCK	2
15	WS-22297	WASHER, FLAT	2
16	SC-22924	HHCS, M6 X 20, W/NO MARKING	1
17	NU-2215	NUT,10-32 UNF HEX MS,18-8 SST	4
18	SC-23670	SCREW,10-32X1/2,NF PHIL,FLAT,	4
19	BT-26884	BRACKET, TETHER.	1
20	SN-38110	SENSOR, 100 OHM, 110" WIRE,	2
21	BK-29605	BLOCK, SENSOR, ELEC. CONTROL	2
22	1493	GUARD SENSOR,W/MW	2
23	NU-26526	NUT, #8-32 UNC KEPS ZP	4
24	1006871	NON-PRODUCT PROBE SEAL	2
25	SC-2459	8-32 x 1/4" PHIL SCREW	2
26	NU-2296	NUT, HEX #8-32	2
27	RI-2100	RIVET,BLIND,#44,STNLS	32

1200-UP Bonnet Package "K", 120V Electronic w/Timer

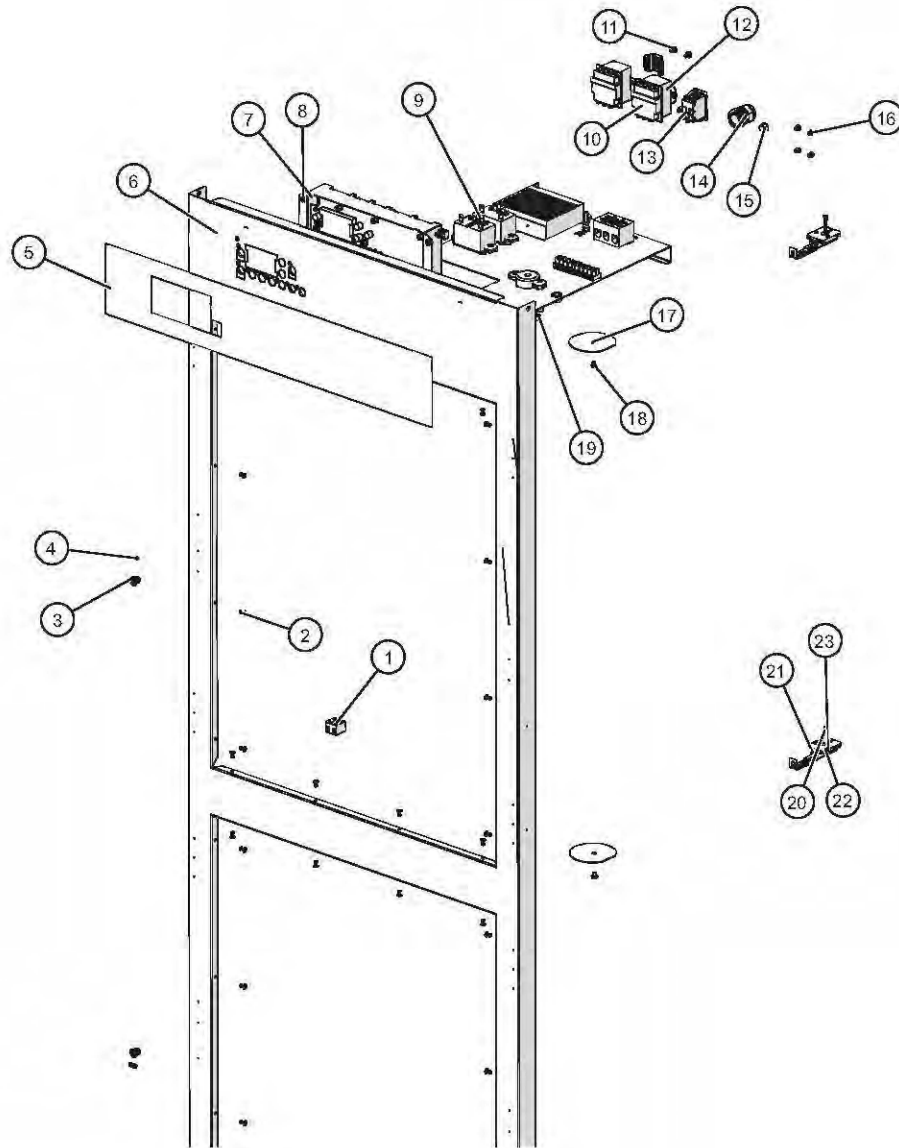

ID	Part No.	Description	Qty
1	BK-33546	BLOCK, 2 TERMINAL, PORCELAIN	1
2	RI-2100	RIVET,BLIND,#44,STNLS	32
3	BU-3419	3/8" BLACK HOLE BUSHING	2
4	SW-33559	SWITCH, REED, SPST	2
5	PE-27855	1200-UP, ELEC, OVERLAY	1
6	5012660	1200-UP ELEC FRONT TRIM ASSY	1
7	CC-34328	CONTROL W/ TIMERS	1
8	NU-26526	NUT, #8-32 UNC KEPS ZP	4
9	5012943	1200-UP ELEC 120V, ELEC. CH	1
10	TT-34800	THERMOSTAT, 300F HI-LIMIT	2
11	SC-22271	SCREWS,M4-0.7X6MM PHIL	4
12	1003936	HI-LIMIT PROTECTION COVER	2
13	SW-34769	SWITCH,ROCKER,125-277V,20A	1
14	BU-3964	BUSHING, STRAIGHT,STRAIN RELIEF	1
15	PG-25574	3/8" HOLE PLUG	1
16	PG-28439	PLUG, DOME, .187" HOLE	4
17	1006871	NON-PRODUCT PROBE SEAL	2
18	SC-2459	8-32 x 1/4" PHIL SCREW	2
19	NU-2296	NUT, HEX #8-32	2
20	SN-38110	SENSOR, 100 OHM, 110" WIRE,	2
21	1493	GUARD SENSOR,W/MW	2
22	BK-29605	BLOCK, SENSOR, ELEC. CONTROL	2
23	SC-22271	SCREW,M4x0.7X6MM PAN	4

1200-UP Bonnet Package "N", 230V Electronic w/Timer

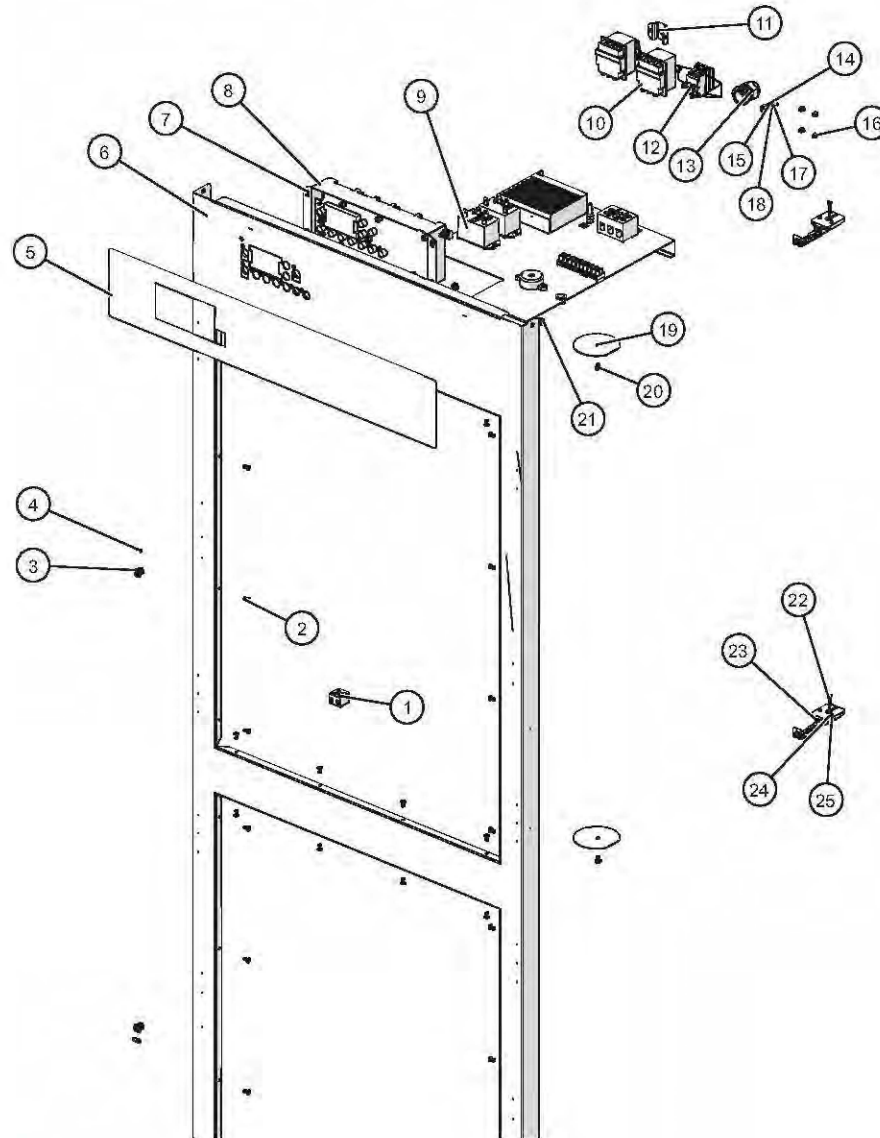

ID	Part No.	Description	Qty
1	BK-33546	BLOCK, 2 TERMINAL, PORCELAIN	1
2	RI-2100	RIVET,BLIND,#44,STNLS	32
3	BU-3419	3/8" BLACK HOLE BUSHING	2
4	SW-33559	SWITCH, REED, SPST	2
5	PE-27855	1200-UP, ELEC, OVERLAY	1
6	5012660	1200-UP ELEC FRONT TRIM ASSY	1
7	NU-26526	NUT, #8-32 UNC KEPS ZP	4
8	CC-34328	CONTROL W/ TIMERS	1
9	5012942	1200-UP ELEC 230V, ELEC. CH	1
10	TT-34600	THERMOSTAT, 300F HI-LIMIT	2
11	1003936	HI-LIMIT PROTECTION COVER	2
12	SW-34769	SWITCH,ROCKER,125-277V,20A	1
13	BU-3964	BUSHING,STRAIGHT,STRAIN RELIEF	1
14	NU-22770	NUT, THREADED INSERT, M6	1
15	WS-22302	WASHER, SPLIT LOCK	2
16	PG-28439	PLUG, DOME, .187" HOLE	4
17	SC-22924	HHCS, M6 X 20, W/NO MARKING	1
18	WS-22297	WASHER, FLAT	2
19	1006871	NON-PRODUCT PROBE SEAL	2
20	SC-2459	8-32 x 1/4" PHIL SCREW	2
21	NU-2296	NUT, HEX #8-32	2
22	SN-38110	SENSOR, 100 OHM, 110" WIRE,	2
23	1493	GUARD SENSOR,W/MW	2
24	BK-29605	BLOCK, SENSOR, ELEC. CONTROL	2
25	SC-22271	SCREW,M4x0.7X6MM PAN	4

1200-UP Bonnet Package "O", 230V 3700W Electronic w/Timer

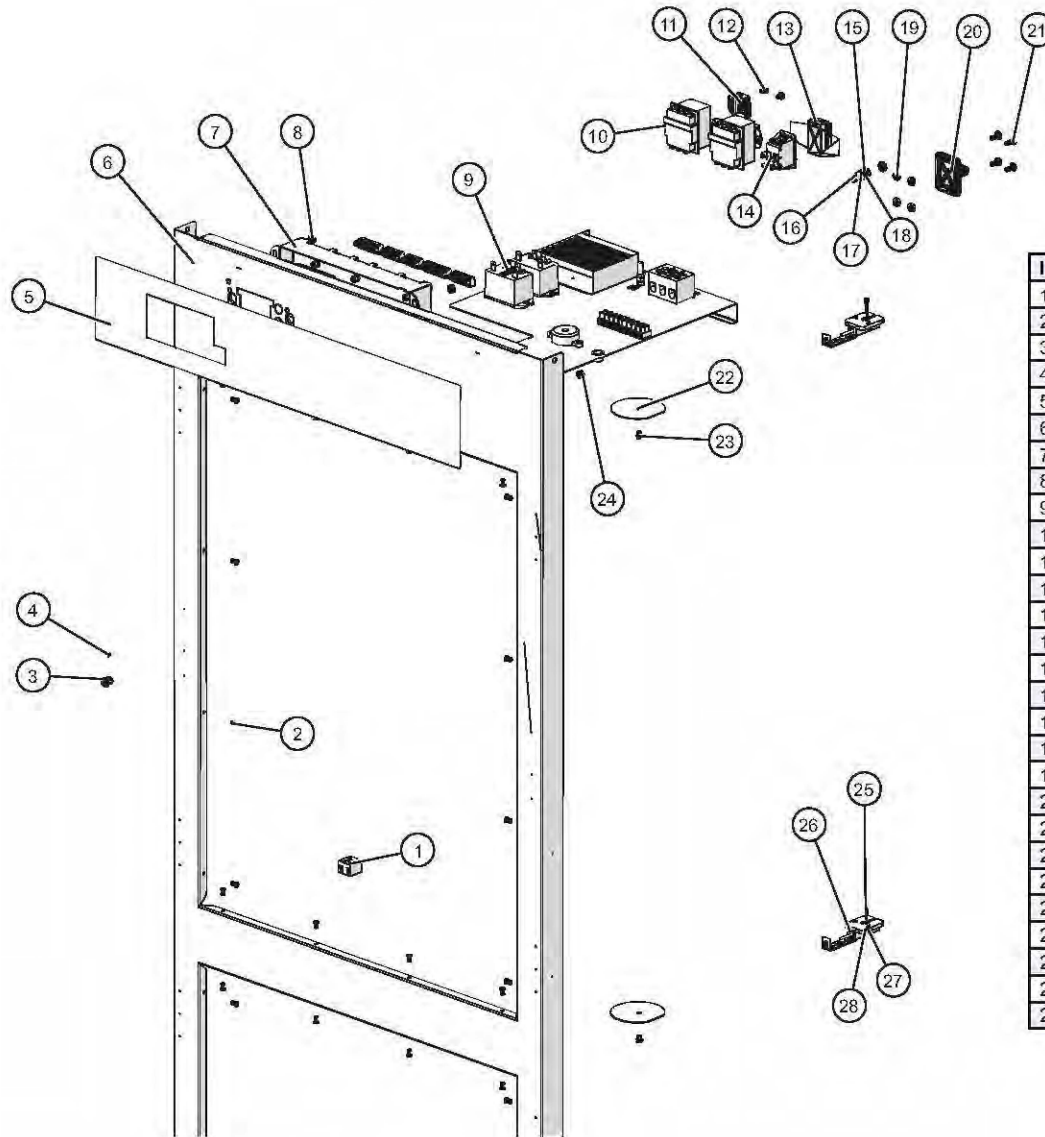

ID	Part No.	Description	Qty
1	BK-33546	BLOCK, 2 TERMINAL, PORCELAIN	1
2	RI-2100	RIVET,BLIND,#44,STNLS	32
3	BU-3419	3/8" BLACK HOLE BUSHING	2
4	SW-33559	SWITCH, REED, SPST	2
5	PE-27855	1200-UP, ELEC, OVERLAY	1
6	5012660	1200-UP ELEC FRONT TRIM STUD WELD	1
7	CC-34328	CONTROL W/ TIMERS	1
8	NU-26526	NUT, #8-32 UNC KEPS ZP	4
9	5012664	1200-UP ELEC 230V 3700W, ELEC	1
10	TT-34600	THERMOSTAT, 300F HI-LIMIT	2
11	1003936	HI-LIMIT PROTECTION COVER	2
12	SC-22271	SCREW,M4x0.7X6MM PAN	4
13	CV-38297	COVER, IPX RATED, SW-34769	1
14	SW-34769	SWITCH,ROCKER,125-277V,20A	1
15	WS-22297	WASHER, FLAT	2
16	NU-22770	NUT, THREADED INSERT, M6	1
17	WS-22302	WASHER, SPLIT LOCK	2
18	SC-22924	HHCS, M6 X 20, W/NO MARKING	1
19	NU-2215	NUT,10-32 UNF HEX MS,18-8 SST	4
20	BT-26884	BRACKET, TETHER.	1
21	SC-23670	SCREW,10-32X1/2,NF PHIL,FLAT,	4
22	1006871	NON-PRODUCT PROBE SEAL	2
23	SC-2459	8-32 x 1/4" PHIL SCREW	2
24	NU-2296	NUT, HEX #8-32	2
25	SN-38110	SENSOR, 100 OHM, 110" WIRE,	2
26	1493	GUARD SENSOR,W/MW	2
27	SC-22271	SCREW,M4x0.7X6MM PAN	4
28	BK-29605	BLOCK, SENSOR, ELEC. CONTROL	2

1200-UP Bonnet Package "P", 120V Electronic w/Probe

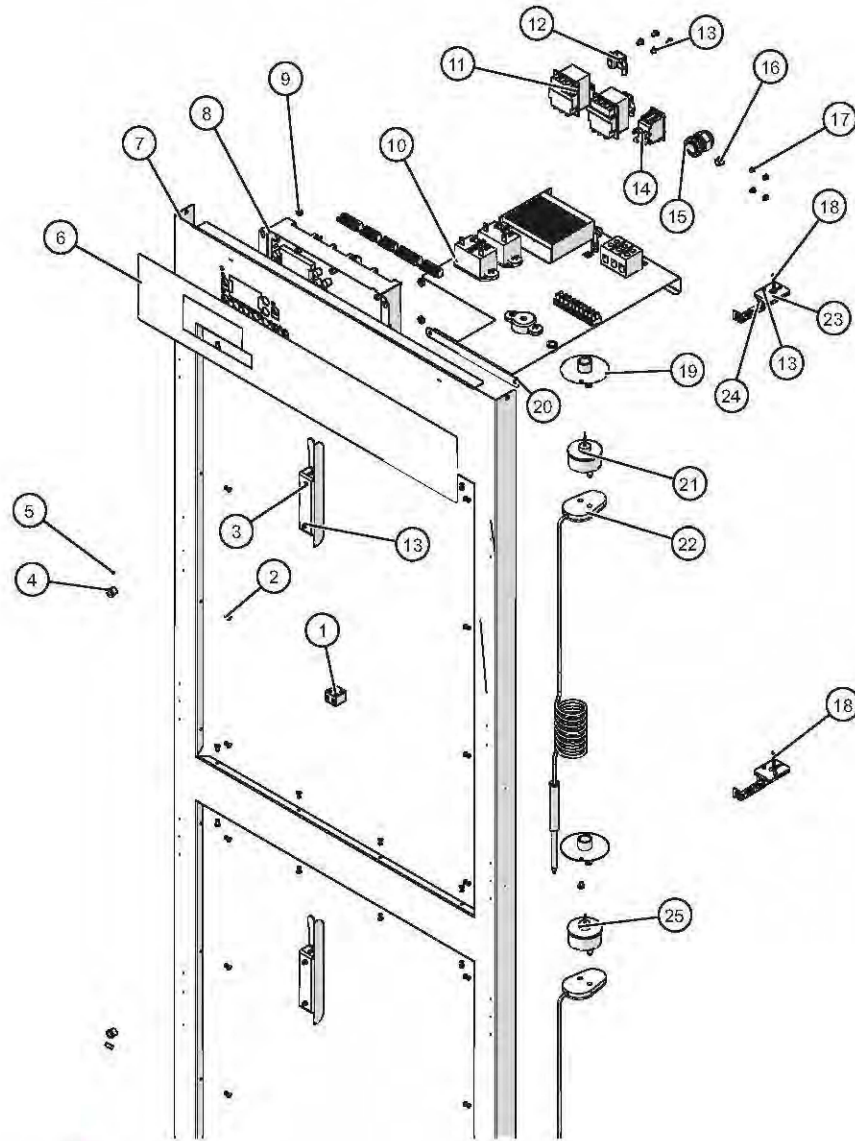

ID	Part No.	Description	Qty
1	BK-33546	BLOCK, 2 TERMINAL, PORCELAIN	1
2	RI-2100	RIVET,BLIND,#44,STNLS	32
3	13239	PROBE HOLDER, TH/III	2
4	BU-3419	3/8" BLACK HOLE BUSHING	2
5	SW-33559	SWITCH, REED, SPST	2
6	PE-27855	1200-UP, ELEC, OVERLAY	1
7	5012660	1200-UP ELEC FRONT TRIM ASSY	1
8	CC-34326	CONTROL W/O TIMERS	1
9	NU-26526	NUT, #8-32 UNC KEPS ZP	4
10	5012943	1200-UP ELEC 120V, ELEC. CH	1
11	TT-34600	THERMOSTAT, 300F HI-LIMIT	2
12	1003936	HI-LIMIT PROTECTION COVER	2
13	SC-22271	SCREW,M4x0.7X6MM PAN	16
14	SW-34769	SWITCH,ROCKER,125-277V,20A	1
15	BU-3964	BUSHING,STRAIGHT,STRAIN RELIEF	1
16	PG-25574	3/8" HOLE PLUG	1
17	PG-28439	PLUG, DOME,.187" HOLE	4
18	SN-38110	SENSOR, 100 OHM, 110" WIRE,	2
19	5009712	PROBE COVER WELDMENT	1
20	NU-2296	NUT, HEX #8-32	2
21	PR-34705	PROBE,RECEPTACLE,600MM WIRE	1
22	PR-36065	PROBE,QUICK CONNECT,PT100	2
23	BK-29605	BLOCK, SENSOR, ELEC. CONTROL	2
24	1493	GUARD SENSOR,W/MW	2
25	PR-34704	PROBE, RECEPTACLE, 2200MM WIRE	1

1200-UP Bonnet Package "Q", 208V-240V Electronic w/Probe

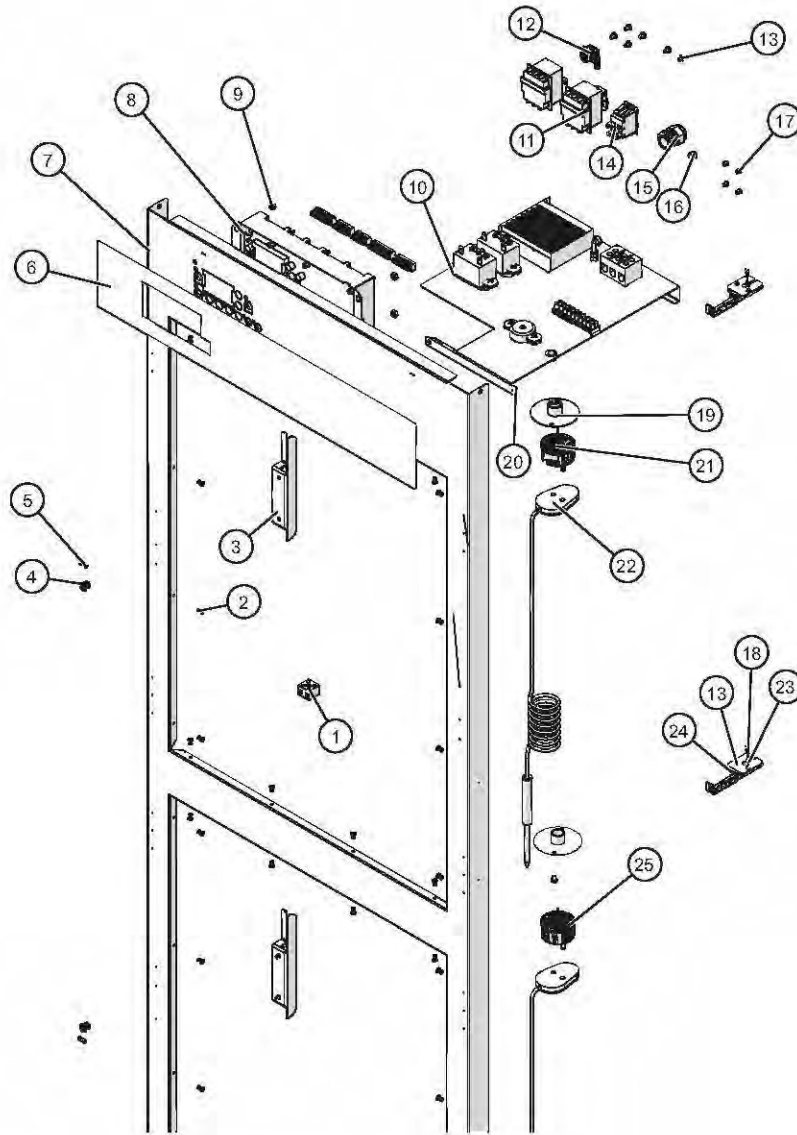

ID	Part No.	Description	Qty
1	BK-33546	BLOCK, 2 TERMINAL, PORCELAIN	1
2	RI-2100	RIVET,BLIND,#44,STNLS	32
3	13239	PROBE HOLDER, TH/III	2
4	BU-3419	3/8" BLACK HOLE BUSHING	2
5	SW-33559	SWITCH, REED, SPST	2
6	PE-27855	1200-UP, ELEC, OVERLAY	1
7	5012660	1200-UP ELEC FRONT TRIM ASSY	1
8	CC-34326	CONTROL W/O TIMERS	1
9	NU-26526	NUT, #8-32 UNC KEPS ZP	4
10	5012941	1200-UP ELEC 208/240V, ELEC	1
11	TT-34600	THERMOSTAT, 300F HI-LIMIT	2
12	1003936	HI-LIMIT PROTECTION COVER	2
13	SC-22271	SCREW,M4x0.7X6MM PAN	16
14	SW-34769	SWITCH,ROCKER,125-277V,20A	1
15	BU-3964	BUSHING,STRAIGHT,STRAIN RELIEF	1
16	PG-25574	3/8" HOLE PLUG	1
17	PG-28439	PLUG, DOME,.187" HOLE	4
18	SN-38110	SENSOR, 100 OHM, 110" WIRE,	2
19	5009712	PROBE COVER WELDMENT	1
20	NU-2296	NUT, HEX #8-32	2
21	PR-34705	PROBE,RECEPTACLE,600MM WIRE	1
22	PR-36065	PROBE,QUICK CONNECT,PT100	2
23	BK-29605	BLOCK, SENSOR, ELEC. CONTROL	2
24	1493	GUARD SENSOR,W/MW	2
25	PR-34704	PROBE, RECEPTACLE, 2200MM WIRE	1

1200-UP Bonnet Package "S", 230V Electronic w/Probe

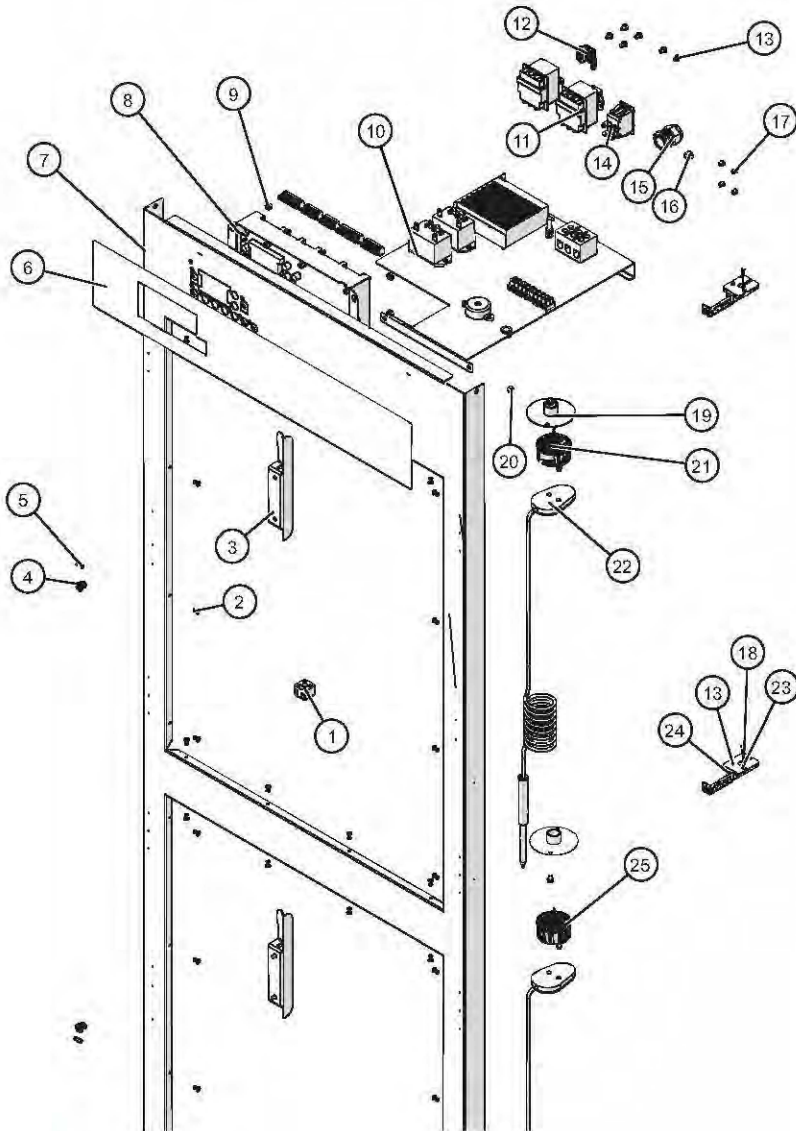

ID	Part No.	Description	Qty
1	BK-33546	BLOCK, 2 TERMINAL, PORCELAIN	1
2	RI-2100	RIVET,BLIND,#44,STNLS	32
3	13239	PROBE HOLDER, TH/III	2
4	BU-3419	3/8" BLACK HOLE BUSHING	2
5	SW-33559	SWITCH, REED, SPST	2
6	PE-27855	1200-UP, ELEC, OVERLAY	1
7	5012660	1200-UP ELEC FRONT TRIM ASSY	1
8	CC-34326	CONTROL W/O TIMERS	1
9	NU-26526	NUT, #8-32 UNC KEPS ZP	4
10	5012942	1200-UP ELEC 230V, ELEC. CH	1
11	TT-34600	THERMOSTAT, 300F HI-LIMIT	2
12	1003936	HI-LIMIT PROTECTION COVER	2
13	SC-22271	SCREW,M4x0.7X6MM PAN	16
14	SW-34769	SWITCH,ROCKER,125-277V,20A	1
15	BU-3964	BUSHING,STRAIGHT,STRAIN RELIEF	1
16	PG-25574	3/8" HOLE PLUG	1
17	PG-28439	PLUG, DOME,.187" HOLE	4
18	SN-38110	SENSOR, 100 OHM, 110" WIRE,	2
19	5009712	PROBE COVER WELDMENT	1
20	NU-2296	NUT, HEX #8-32	2
21	PR-34705	PROBE,RECEPTACLE,600MM WIRE	1
22	PR-36065	PROBE,QUICK CONNECT,PT100	2
23	BK-29605	BLOCK, SENSOR, ELEC. CONTROL	2
24	1493	GUARD SENSOR,W/MW	2
25	PR-34704	PROBE, RECEPTACLE, 2200MM WIRE	1

1200-UP Bonnet Package "U", 120V Electronic w/Probe & Timer

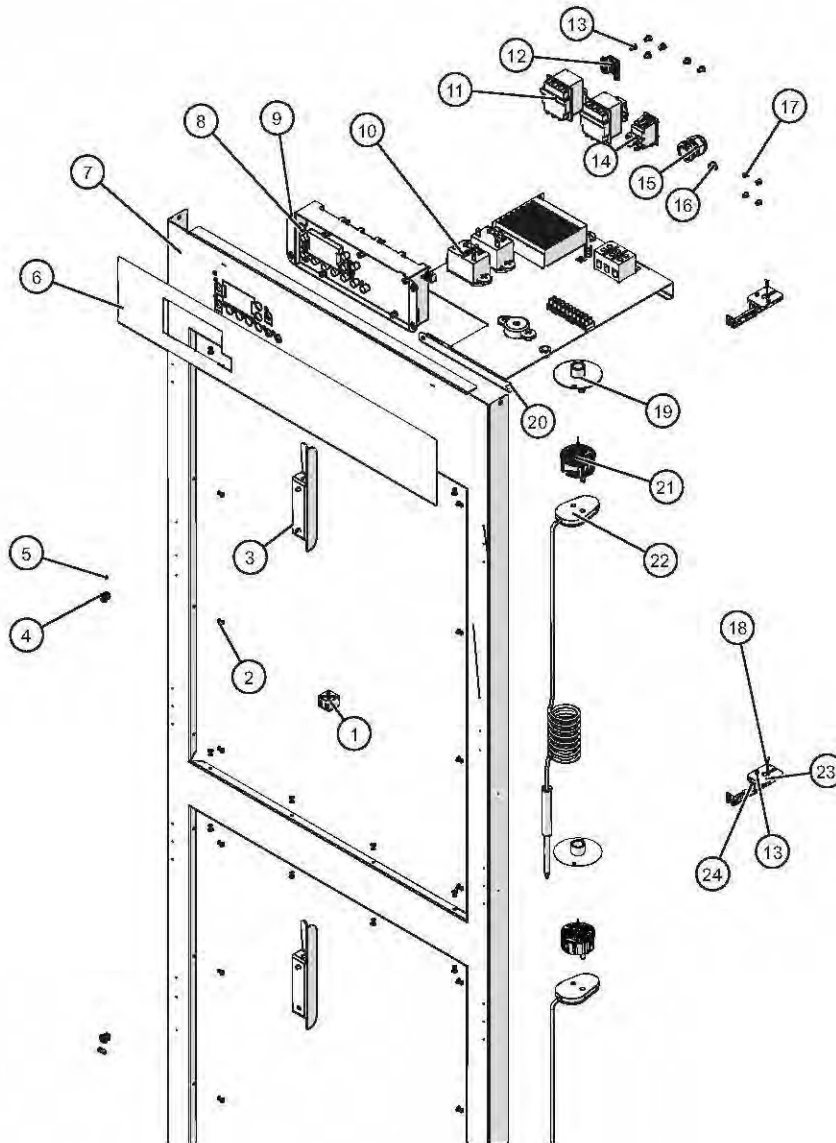

ID	Part No.	Description	Qty
1	BK-33546	BLOCK, 2 TERMINAL, PORCELAIN	1
2	RI-2100	RIVET,BLIND,#44,STNLS	32
3	13239	PROBE HOLDER, TH/III	2
4	BU-3419	3/8" BLACK HOLE BUSHING	2
5	SW-33559	SWITCH, REED, SPST	2
6	PE-27855	1200-UP, ELEC, OVERLAY	1
7	5012660	1200-UP ELEC FRONT TRIM ASSY	1
8	CC-34328	CONTROL W/ TIMERS	1
9	NU-26526	NUT, #8-32 UNC KEPS ZP	4
10	5012943	1200-UP ELEC 120V, ELEC. CH	1
11	TT-34600	THERMOSTAT, 300F HI-LIMIT	2
12	1003936	HI-LIMIT PROTECTION COVER	2
13	SC-22271	SCREW,M4x0.7X6MM PAN	16
14	SW-34769	SWITCH,ROCKER,125-277V,20A	1
15	BU-3964	BUSHING,STRAIGHT,STRAIN RELIEF	1
16	PG-25574	3/8" HOLE PLUG	1
17	PG-28439	PLUG, DOME,.187" HOLE	4
18	SN-38110	SENSOR, 100 OHM, 110" WIRE,	2
19	5009712	PROBE COVER WELDMENT	1
20	NU-2296	NUT, HEX #8-32	2
21	PR-34705	PROBE,RECEPTACLE,600MM WIRE	1
22	PR-36065	PROBE,QUICK CONNECT,PT100	2
23	BK-29605	BLOCK, SENSOR, ELEC. CONTROL	2
24	1493	GUARD SENSOR,W/MW	2

1200-UP Bonnet Package "X", 230V Electronic w/Probe & Timer

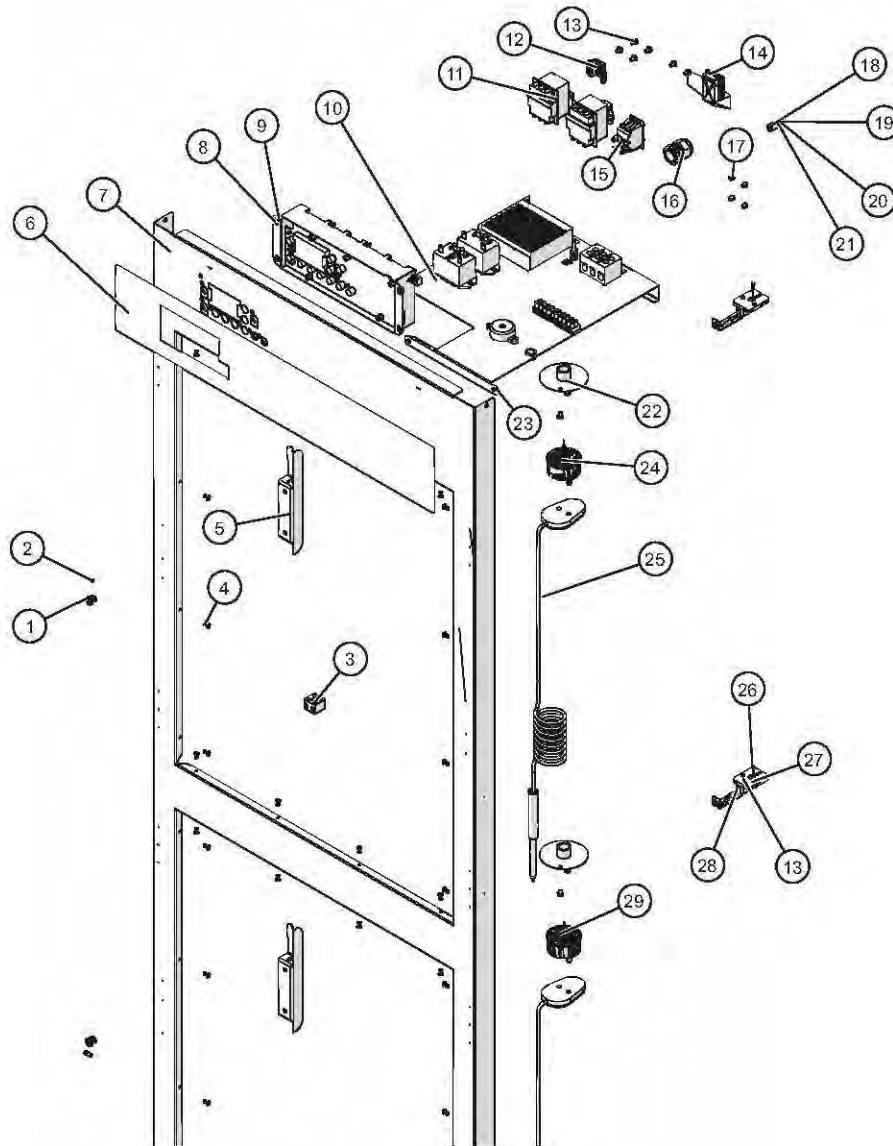

ID	Part No.	Description	Qty
1	BU-3419	3/8" BLACK HOLE BUSHING	2
2	SW-33559	SWITCH, REED, SPST	2
3	BK-33546	BLOCK, 2 TERMINAL, PORCELAIN	1
4	RI-2100	RIVET,BLIND,#44,STNLS	32
5	13239	PROBE HOLDER, TH/III	2
6	PE-27855	1200-UP, ELEC, OVERLAY	1
7	5012660	1200-UP ELEC FRONT TRIM ASSY	1
8	CC-34328	CONTROL W/ TIMERS	1
9	NU-26526	NUT, #8-32 UNC KEPS ZP	4
10	5012942	1200-UP ELEC 230V, ELEC. CH	1
11	TT-34600	THERMOSTAT, 300F HI-LIMIT	2
12	1003936	HI-LIMIT PROTECTION COVER	2
13	SC-22271	SCREW,M4x0.7X6MM PAN	16
14	CV-38297	COVER, IPX RATED, SW-34769	1
15	SW-34769	SWITCH,ROCKER,125-277V,20A	1
16	BU-3964	BUSHING,STRAIGHT,STRAIN RELIEF	1
17	PG-28439	PLUG, DOME,.187" HOLE	4
18	NU-22770	NUT, THREADED INSERT, M6	1
19	WS-22302	WASHER, SPLIT LOCK	2
20	SC-22924	HHCS, M6 X 20, W/NO MARKING	1
21	WS-22297	WASHER, FLAT	2
22	5009712	PROBE COVER WELDMENT	2
23	NU-2296	NUT, HEX #8-32	2
24	PR-34705	PROBE,RECEPTACLE,600MM WIRE	1
25	PR-36065	PROBE,QUICK CONNECT,PT100	2
26	SN-38110	SENSOR, 100 OHM, 110" WIRE,	2
27	BK-29605	BLOCK, SENSOR, ELEC. CONTROL	2
28	1493	GUARD SENSOR,W/MW	2
29	PR-34704	PROBE, RECEPTACLE, 2200MM WIRE	1

1200-S Chassis Assembly, 120V Simple

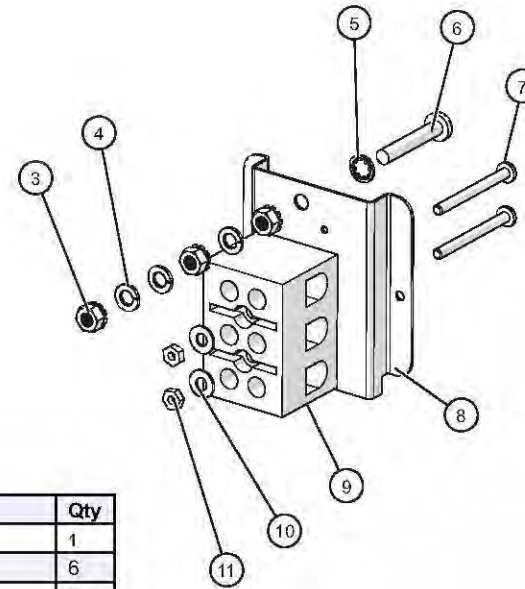
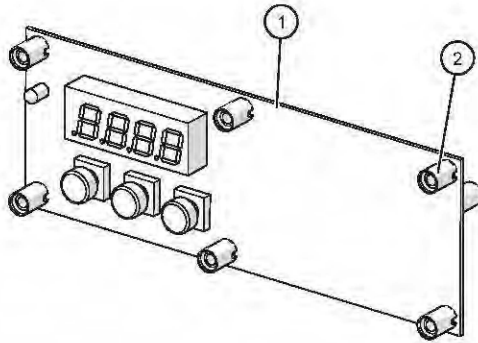

ID	Part No.	Description	Qty
1	CC-34970	LOW COST ELAN WARMER CONTROL	1
2	SP-29392	SPACER, SNAP-IN, 7/16"	6
3	NU-36234	NUT, M5, KEPS	3
4	WS-22301	WASHER, M5 SPLIT LOCK	3
5	WS-2467	WASHER, INT. LOCK	1
6	SC-38128	SCREW,PAN PH, METRIC, M5	1
7	SC-47136	SCREW,6-32X1-1/2" PAN	2
8	1033464	BRACKET,OFFSET,TERMINAL	1
9	BK-3019	T-BLOCK	1
10	WS-23424	WASHER, FLAT, #8, 18-8 SST	2
11	NU-2361	NUT, 6-32 HEX, S/S	2
12	5034795	WIRESET, SGL CAVITY WARMER (not shown)	1

1200-S Chassis Assembly, 120V Simple

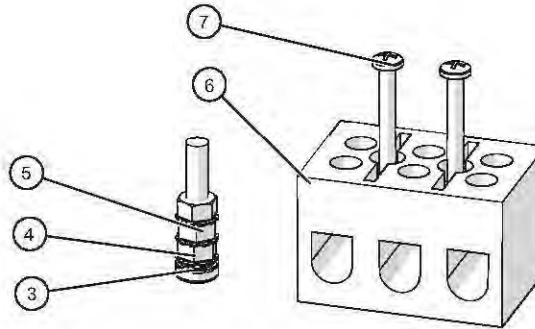
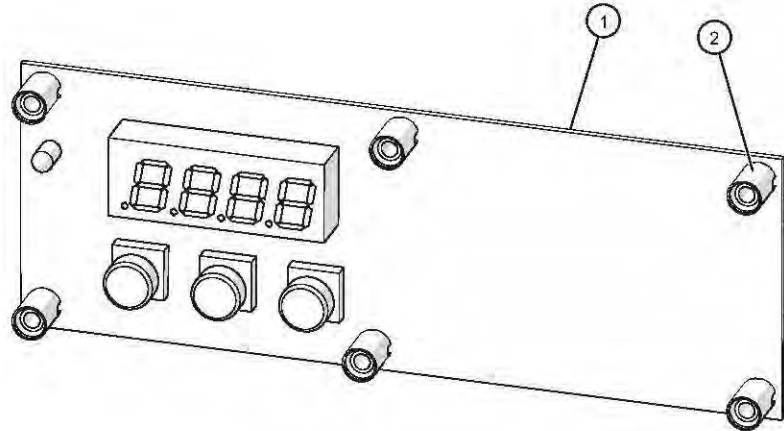

ID	Part No.	Description	Qty
1	CC-34970	ELAN WARMER CONTROL	1
2	SP-29392	SPACER, SNAP-IN, 7/16"	6
3	WS-2467	WASHER, INT. LOCK	1
4	SC-38128	SCREW,PAN PH, METRIC, M5	1
5	NU-36234	NUT, M5, KEPS	3
6	BK-3019	T-BLOCK	1
7	SC-47136	SCREW,6-32X1-1/2" PAN	2

1200-S Chassis Assembly, 208V-240V Simple

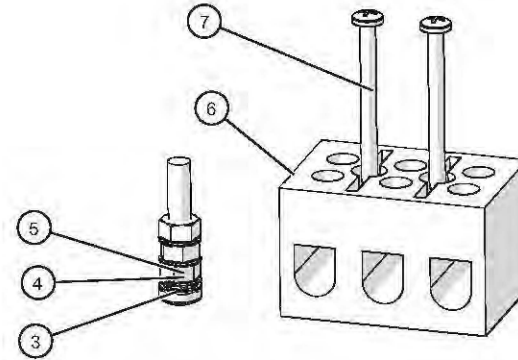
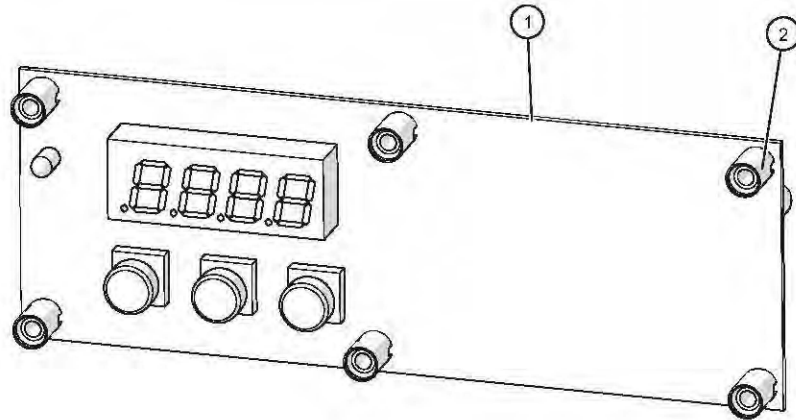

ID	Part No.	Description	Qty
1	CC-34970	ELAN WARMER CONTROL	1
2	SP-29392	SPACER, SNAP-IN, 7/16"	6
3	WS-2467	WASHER, INT. LOCK	1
4	SC-38128	SCREW, PAN PH, METRIC, M5	1
5	NU-36234	NUT, M5, KEPS	3
6	BK-3019	T-BLOCK	1
7	SC-47136	SCREW, 6-32X1-1/2" PAN	2

1200-S Chassis Assembly, 230V Simple

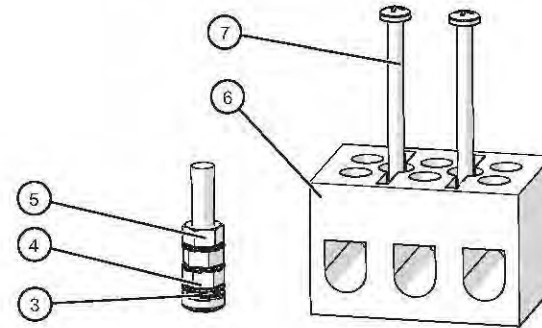
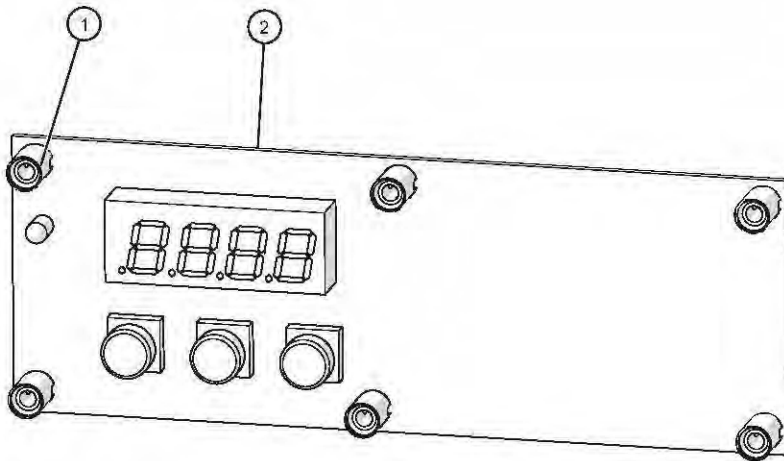

ID	Part No.	Description	Qty
1	SP-29392	SPACER, SNAP-IN, 7/16"	6
2	CC-34970	ELAN WARMER CONTROL	1
3	WS-2467	WASHER, INT. LOCK	1
4	SC-38128	SCREW,PAN PH, METRIC, M5	1
5	NU-36234	NUT, M5, KEPS	3
6	BK-3019	T-BLOCK	1
7	SC-47136	SCREW,6-32X1-1/2" PAN	2

1200-S Chassis Assembly, 208V-240V Deluxe

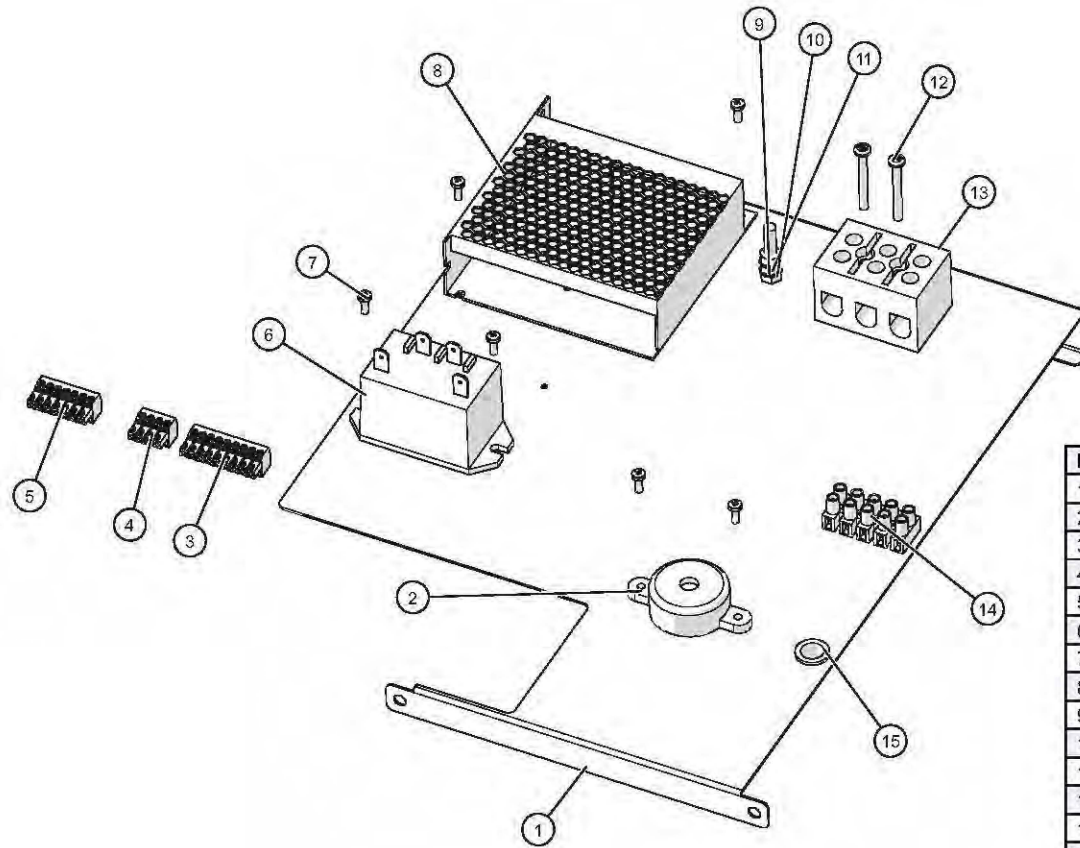

ID	Part No.	Description	Qty
1	1011531	WARMER SERIES ELEC CHASSIS	1
2	BP-3567	BEEPER, SOLID STATE, 1.5-20V	1
3	CR-33718	CONNECTOR 9 PIN	1
4	CR-33763	CONNECTOR 4 PIN	1
5	CR-33761	CONNECTOR, 7 PIN	1
6	RL-33558	RELAY, SPST 30A @ 277 VAC 12VDC	1
7	SC-22268	SCREW,M3x0.5X8MM PAN	6
8	BA-38586	BOARD, POWER SUPPLY, 12V	1
9	SC-38128	SCREW,PAN PH, METRIC, M5	1
10	WS-2467	WASHER, INT. LOCK	1
11	NU-36234	NUT, M5, KEPS	3
12	SC-2365	SCREW,6-32X1-1/4,NC PHILLIPS	2
13	BK-3019	T-BLOCK	1
14	TM-33560	TERMINAL, STRIP,5CIRCUIT,UL,VDE	1
15	BU-3006	1/2" HOLE BUSHING	1

1200-S Chassis Assembly, 230V Deluxe

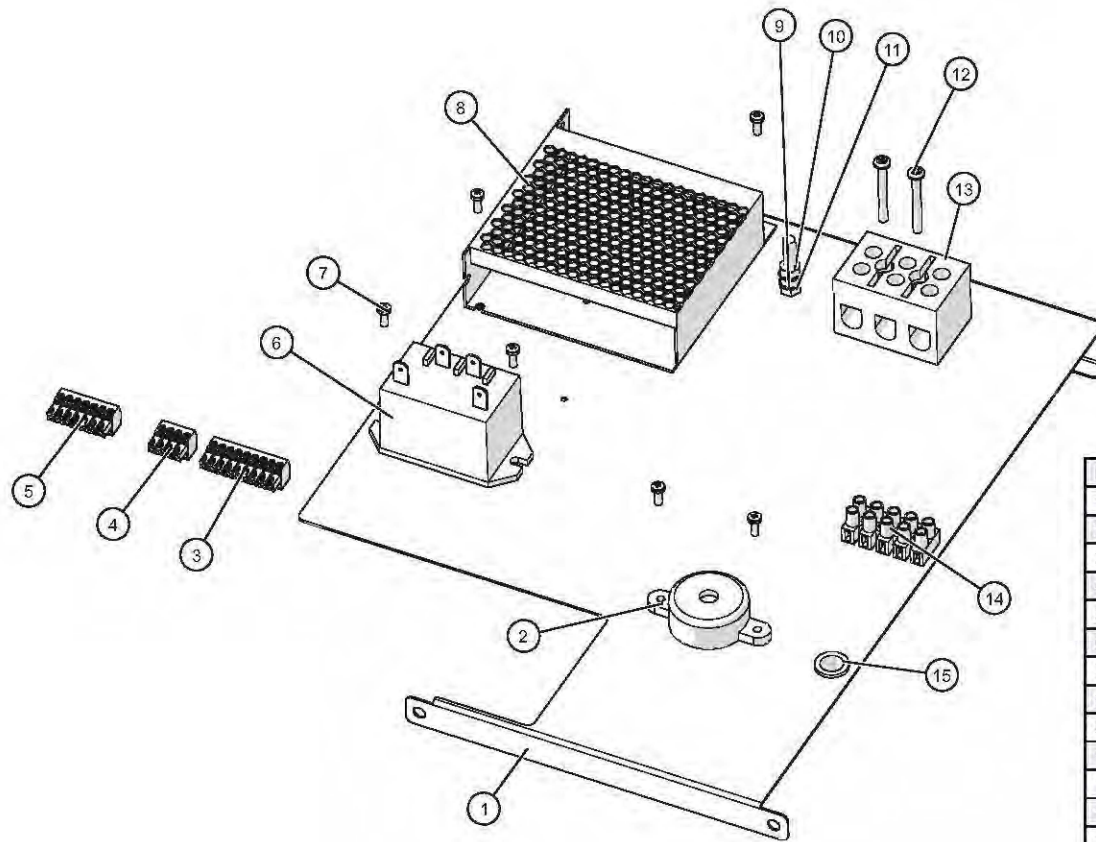

ID	Part No.	Description	Qty
1	1011531	WARMER SERIES ELEC CHASSIS	1
2	BP-3567	BEEPER, SOLID STATE, 1.5-20V	1
3	CR-33718	CONNECTOR 9 PIN	1
4	CR-33763	CONNECTOR 4 PIN	1
5	CR-33761	CONNECTOR, 7 PIN	1
6	RL-33558	RELAY, SPST 30A @ 277 VAC 12VDC	1
7	SC-22268	SCREW, M3x0.5X8MM PAN	6
8	BA-38586	BOARD, POWER SUPPLY, 12V	1
9	SC-38128	SCREW, PAN PH, METRIC, M5	1
10	NU-36234	NUT, M5, KEPS	3
11	WS-2467	WASHER, INT. LOCK	1
12	SC-2365	SCREW, 6-32X1-1/4, NC PHILLIPS	2
13	BK-3019	T-BLOCK	1
14	TM-33560	TERMINAL, STRIP, 5CIRCUIT, UL, VDE	1
15	BU-3006	1/2" HOLE BUSHING	1

1200-S Chassis Assembly, Deluxe (5034305)

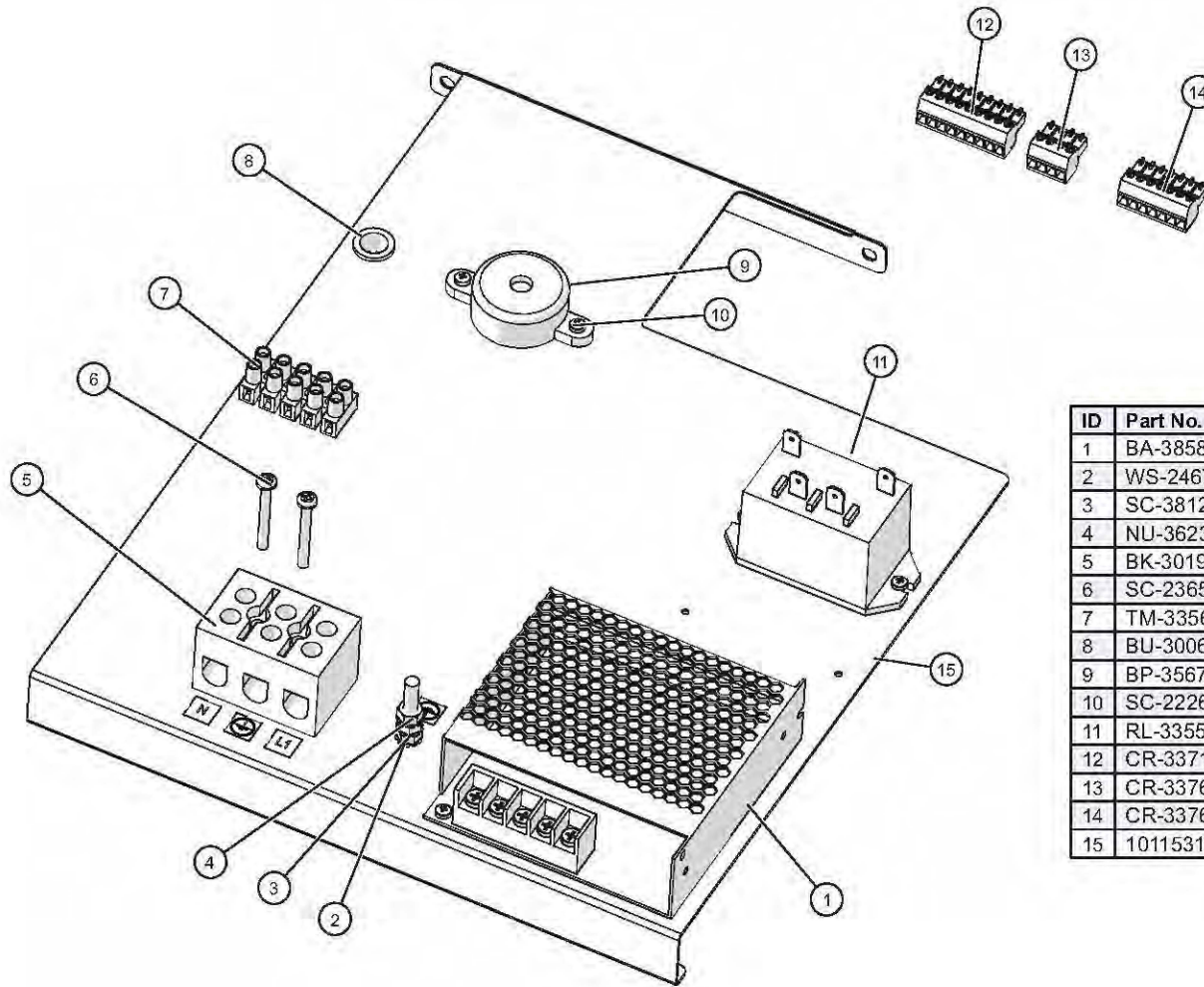

ID	Part No.	Description	Qty
1	BA-38586	BOARD, POWER SUPPLY, 12V	1
2	WS-2467	WASHER, INT. LOCK	1
3	SC-38128	SCREW,PAN PH, METRIC, M5	1
4	NU-36234	NUT, M5, KEPS	3
5	BK-3019	T-BLOCK	1
6	SC-2365	SCREW,6-32X1-1/4,NC PHILLIPS	2
7	TM-33560	TERMINAL,STRIP,5CIRCUIT,UL,VDE	1
8	BU-3006	1/2" HOLE BUSHING	1
9	BP-3567	BEEPER, SOLID STATE, 1.5-20V	1
10	SC-22268	SCREW,M3x0.5X8MM PAN	6
11	RL-33558	RELAY, SPST 30A @ 277 VAC 12VDC	1
12	CR-33718	CONNECTOR 9 PIN	1
13	CR-33763	CONNECTOR 4 PIN	1
14	CR-33761	CONNECTOR, 7 PIN	1
15	1011531	WARMER SERIES ELEC CHASSIS	1

1200-UP Chassis Assembly, 120V Electronic

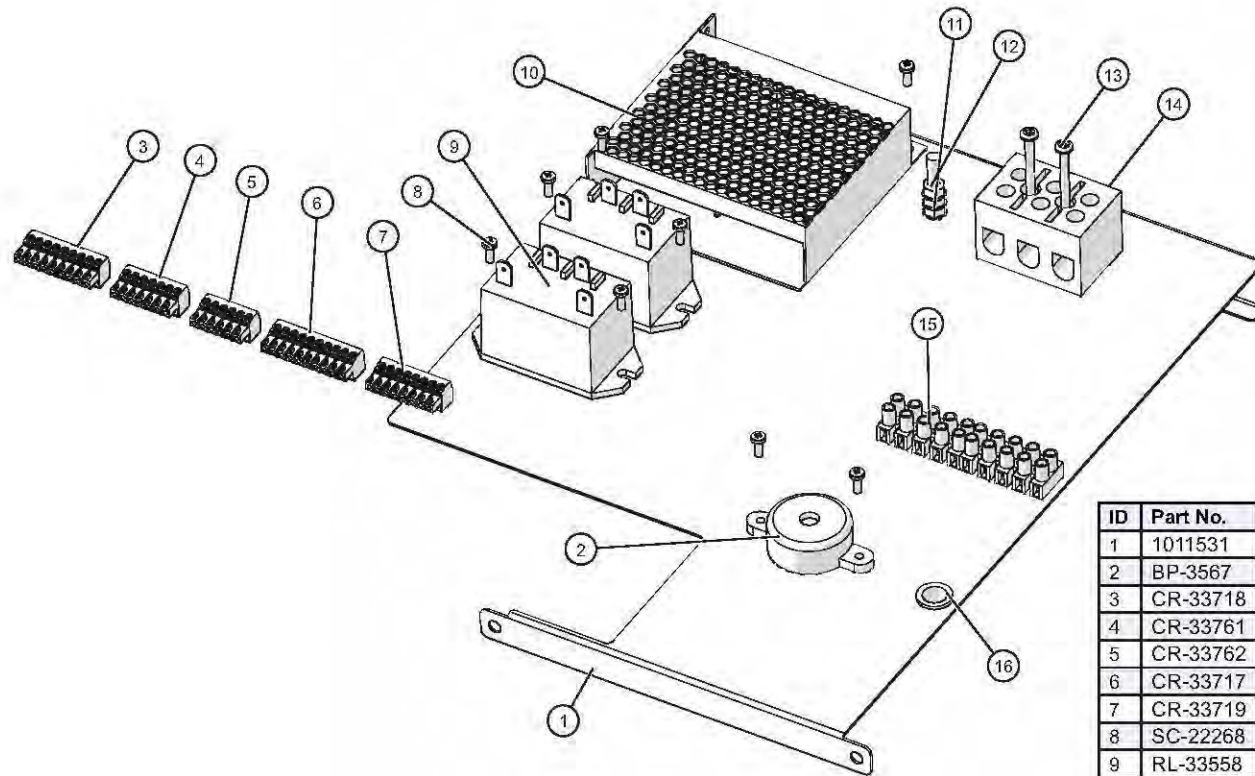

ID	Part No.	Description	Qty
1	1011531	WARMER SERIES ELEC CHASSIS	1
2	BP-3567	BEEPER, SOLID STATE, 1.5-20V	1
3	CR-33718	CONNECTOR 9 PIN	1
4	CR-33761	CONNECTOR, 7 PIN	1
5	CR-33762	CONNECTOR 6 PIN	1
6	CR-33717	CONNECTOR, 10 PIN	1
7	CR-33719	CONNECTOR 8 PIN	1
8	SC-22268	SCREW, M3x0.5X8MM PAN	8
9	RL-33558	RELAY, SPST 30A @ 277 VAC 12VDC	2
10	BA-38586	BOARD, POWER SUPPLY, 12V	1
11	SC-38128	SCREW, PAN PH, METRIC, M5	1
12	NU-36234	NUT, M5, KEPS	3
13	SC-2365	SCREW, 6-32X1-1/4, NC PHILLIPS	2
14	BK-3019	T-BLOCK	1
15	TM-33560	TERMINAL, STRIP, 5 CIRCUIT, UL, VDE	2
16	BU-3006	1/2" HOLE BUSHING	1

1200-UP Control Assembly, 120V Manual

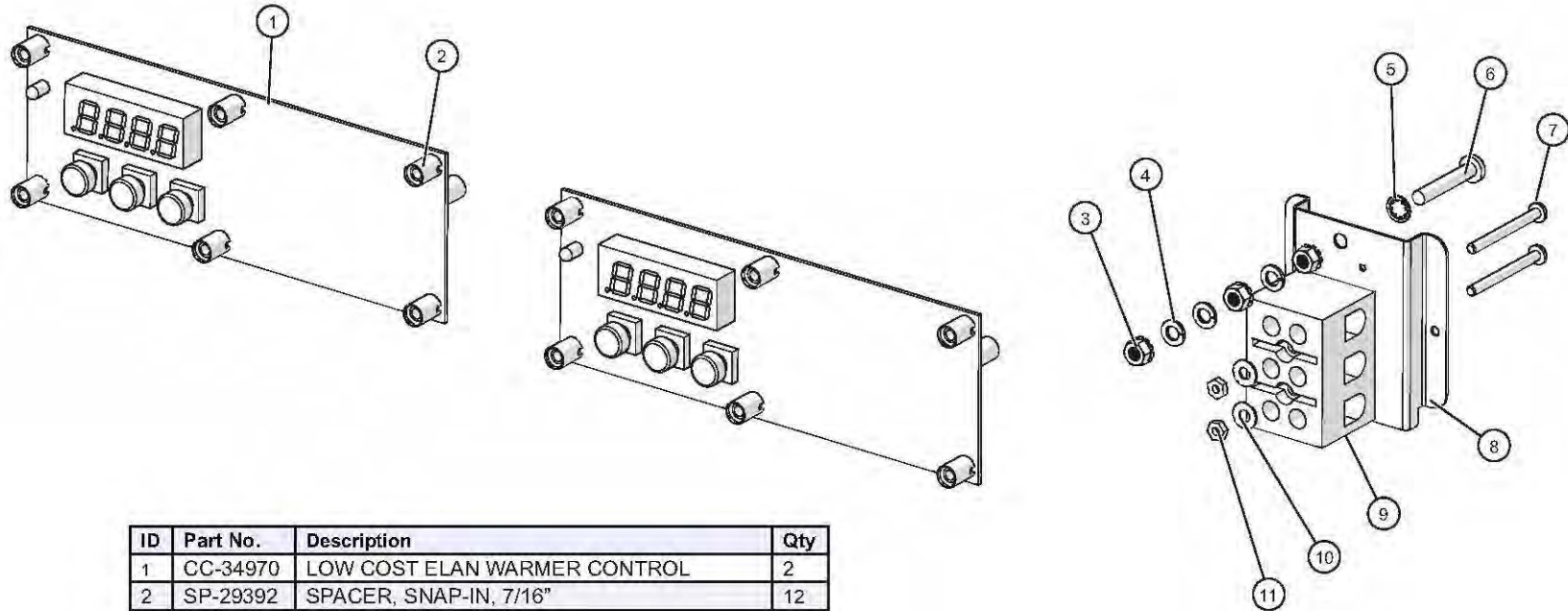

ID	Part No.	Description	Qty
1	CC-34970	LOW COST ELAN WARMER CONTROL	2
2	SP-29392	SPACER, SNAP-IN, 7/16"	12
3	NU-36234	NUT, M5, KEPS	3
4	WS-22301	WASHER, M5 SPLIT LOCK	3
5	WS-2467	WASHER, INT. LOCK	1
6	SC-38128	SCREW,PAN PH, METRIC, M5	1
7	SC-47136	SCREW,6-32X1-1/2" PAN	2
8	1033464	BRACKET,OFFSET,TERMINAL	1
9	BK-3019	T-BLOCK	1
10	WS-23424	WASHER, FLAT, #8, 18-8 SST	2
11	NU-2361	NUT, 6-32 HEX, S/S	2
12	5034795	WIRESET, DBL CAVITY WARMER (not shown)	1

1200-UP Chassis Assembly, 208V-240V Electronic

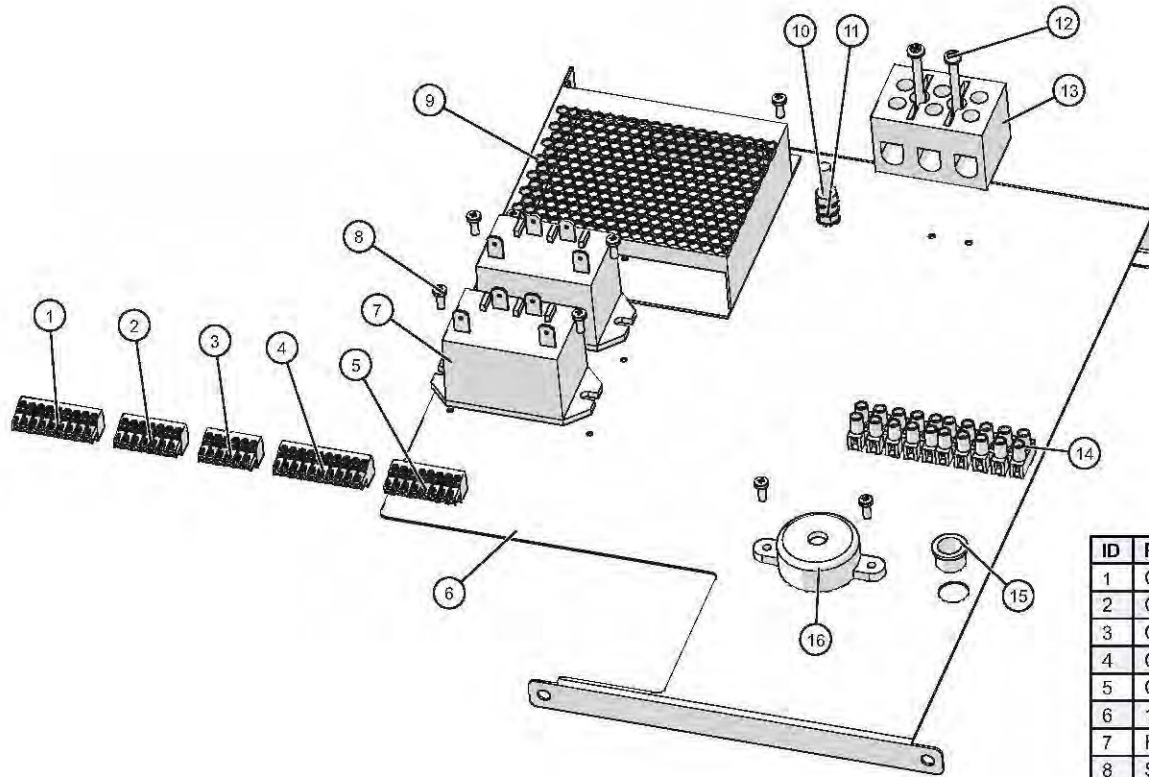

ID	Part No.	Description	Qty
1	CR-33718	CONNECTOR 9 PIN	1
2	CR-33761	CONNECTOR, 7 PIN	1
3	CR-33762	CONNECTOR 6 PIN	1
4	CR-33717	CONNECTOR, 10 PIN	1
5	CR-33719	CONNECTOR 8 PIN	1
6	1011531	WARMER SERIES ELEC CHASSIS	1
7	RL-33558	RELAY, SPST 30A @ 277 VAC 12VDC	2
8	SC-22268	SCREW, M3x0.5X8MM PAN	8
9	BA-38586	BOARD, POWER SUPPLY, 12V	1
10	NU-36234	NUT, M5, KEPS	3
11	SC-38128	SCREW, PAN PH, METRIC, M5	1
12	SC-2365	SCREW, 6-32X1-1/4, NC PHILLIPS	2
13	BK-3019	T-BLOCK	1
14	TM-33560	TERMINAL STRIP, 5 CIRCUIT, UL, VDE	2
15	BU-3006	1/2" HOLE BUSHING	1
16	BP-3567	BEEPER, SOLID STATE, 1.5-20V	1

1200-UP Chassis Assembly, 230V Electronic

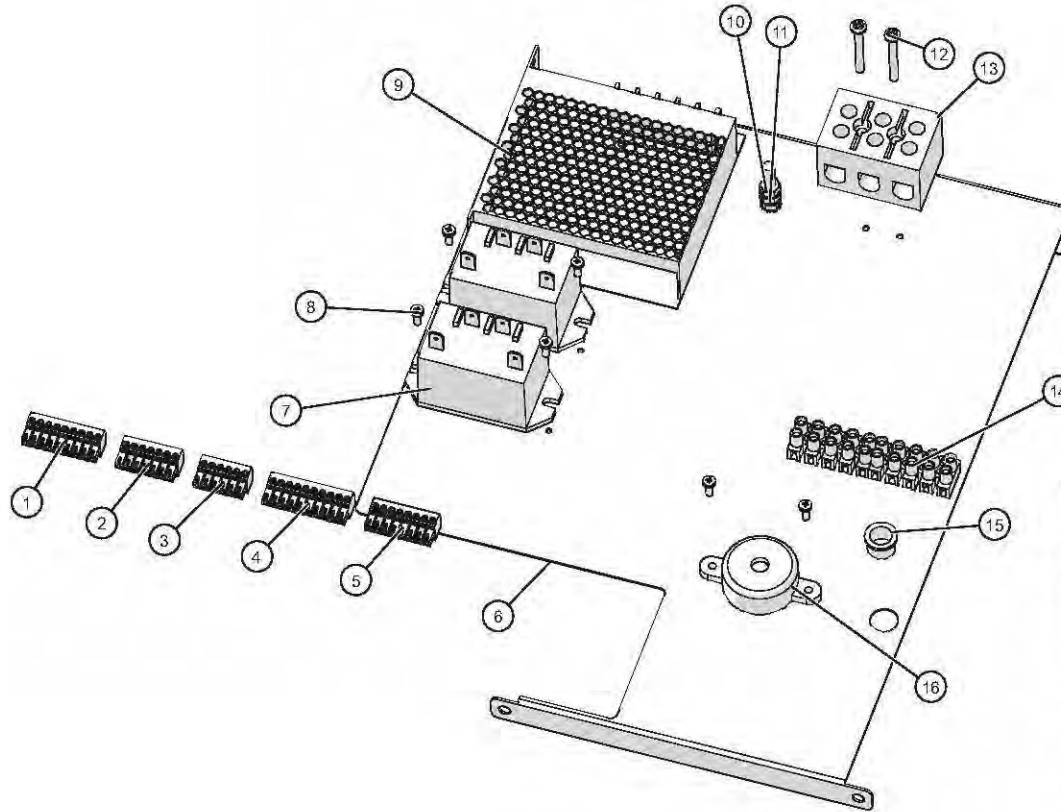

ID	Part No.	Description	Qty
1	CR-33718	CONNECTOR 9 PIN	1
2	CR-33761	CONNECTOR, 7 PIN	1
3	CR-33762	CONNECTOR 6 PIN	1
4	CR-33717	CONNECTOR, 10 PIN	1
5	CR-33719	CONNECTOR 8 PIN	1
6	1011531	WARMER SERIES ELEC CHASSIS	1
7	RL-33558	RELAY, SPST 30A @ 277 VAC 12VDC	2
8	SC-22268	SCREW,M3x0.5X8MM PAN	8
9	BA-38586	BOARD, POWER SUPPLY, 12V	1
10	NU-36234	NUT, M5, KEPS	3
11	SC-38128	SCREW,PAN PH, METRIC, M5	1
12	SC-2365	SCREW,6-32X1-1/4,NC PHILLIPS	2
13	BK-3019	T-BLOCK	1
14	TM-33560	TERMINAL,STRIP,5 CIRCUIT,UL,VDE	2
15	BU-3006	1/2" HOLE BUSHING	1
16	BP-3567	BEEPER, SOLID STATE, 1.5-20V	1

1200-UP Chassis Assembly, 2000W Electronic

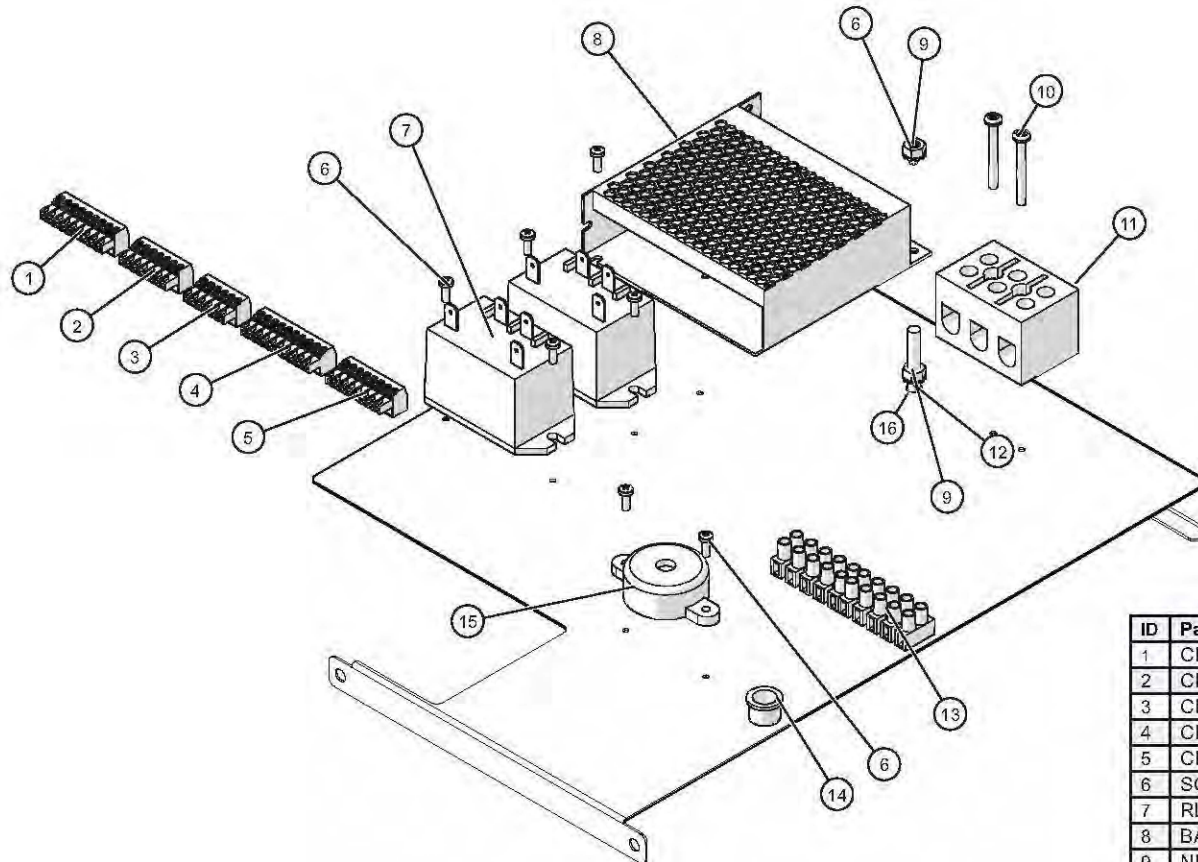

ID	Part No.	Description	Qty
1	CR-33718	CONNECTOR 9 PIN	1
2	CR-33761	CONNECTOR, 7 PIN	1
3	CR-33762	CONNECTOR 6 PIN	1
4	CR-33717	CONNECTOR, 10 PIN	1
5	CR-33719	CONNECTOR 8 PIN	1
6	SC-22268	SCREW, M3x0.5X8MM PAN	8
7	RL-33558	RELAY, SPST 30A @ 277 VAC 12VDC	2
8	BA-38586	BOARD, POWER SUPPLY, 12V	1
9	NU-36234	NUT, M5, KEPS	3
10	SC-2365	SCREW, 6-32X1-1/4, NC PHILLIPS	2
11	BK-3019	T-BLOCK	1
12	SC-38128	SCREW, PAN PH, METRIC, M5	1
13	TM-33560	TERMINAL, STRIP, 5 CIRCUIT, UL, VDE	2
14	BU-3006	1/2" HOLE BUSHING	1
15	BP-3567	BEEPER, SOLID STATE, 1.5-20V	1
16	WS-2467	WASHER, INT. LOCK, #10, 410 SST	1

1200-UP Chassis Assembly, 230V 3700W Electronic

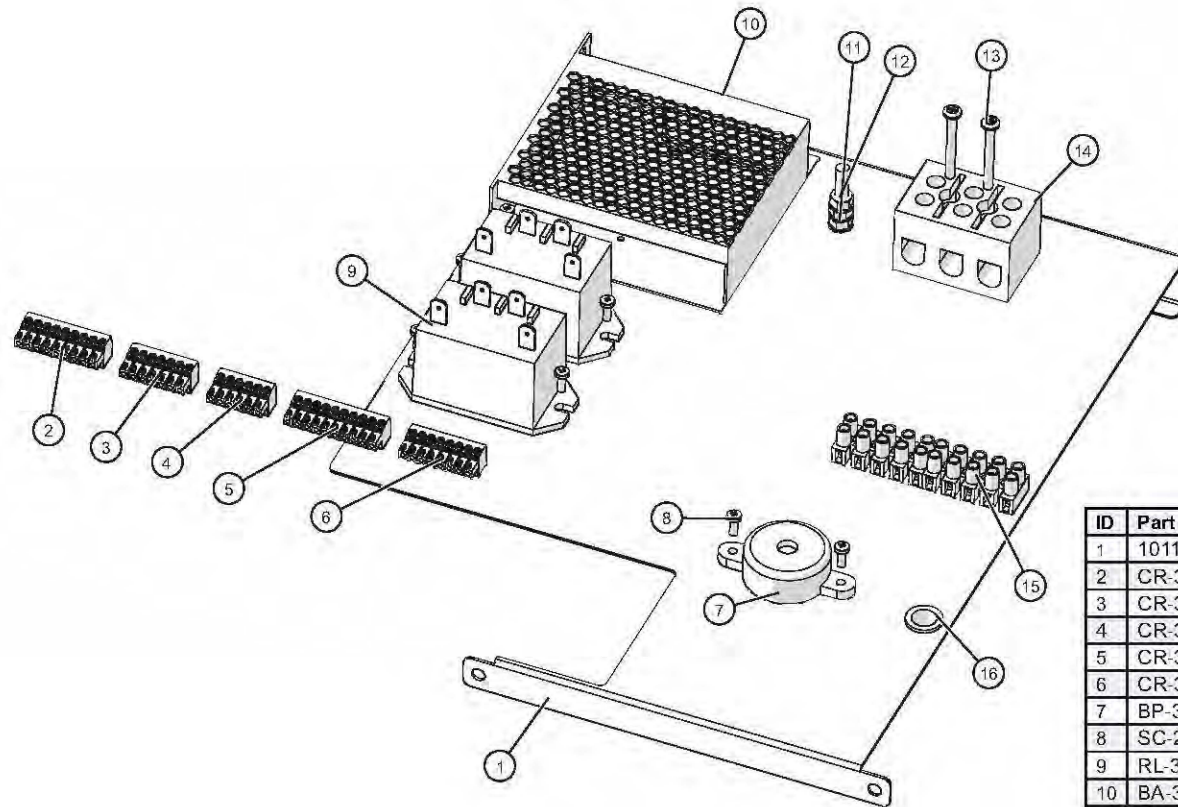

ID	Part No.	Description	Qty
1	1011531	WARMER SERIES ELEC CHASSIS	1
2	CR-33718	CONNECTOR 9 PIN	1
3	CR-33761	CONNECTOR, 7 PIN	1
4	CR-33762	CONNECTOR 6 PIN	1
5	CR-33717	CONNECTOR, 10 PIN	1
6	CR-33719	CONNECTOR 8 PIN	1
7	BP-3567	BEEPER, SOLID STATE, 1.5-20V	1
8	SC-22268	SCREW,M3x0.5X8MM PAN	8
9	RL-33558	RELAY, SPST 30A @ 277 VAC 12VDC	2
10	BA-38586	BOARD, POWER SUPPLY, 12V	1
11	SC-38128	SCREW,PAN PH, METRIC, M5	1
12	NU-36234	NUT, M5, KEPS	3
13	SC-2365	SCREW,6-32X1-1/4,NC PHILLIPS	2
14	BK-3019	T-BLOCK	1
15	TM-33560	TERMINAL,STRIP,5 CIRCUIT,UL,VDE	2
16	BU-3006	1/2" HOLE BUSHING	1

1200-UP Chassis Assembly, 208V-240V 4000W Manual

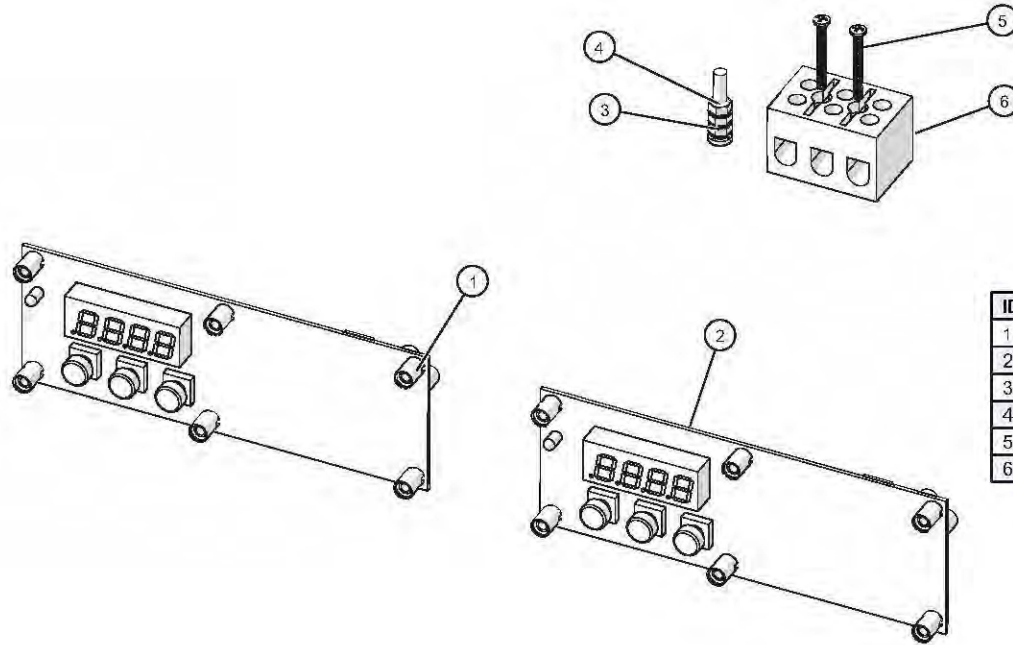

ID	Part No.	Description	Qty
1	SP-29392	SPACER, SNAP-IN, 7/16"	12
2	CC-34970	LOW COST ELAN WARMER CONTROL	2
3	SC-38128	SCREW,PAN PH, METRIC, M5	1
4	NU-36234	NUT, M5, KEPS	3
5	SC-2365	SCREW, 6-32 X 1 1/4" ROUND HD	2
6	BK-3019	T-BLOCK	1

1200-UP Chassis Assembly, 208V-240V 4000W Electronic

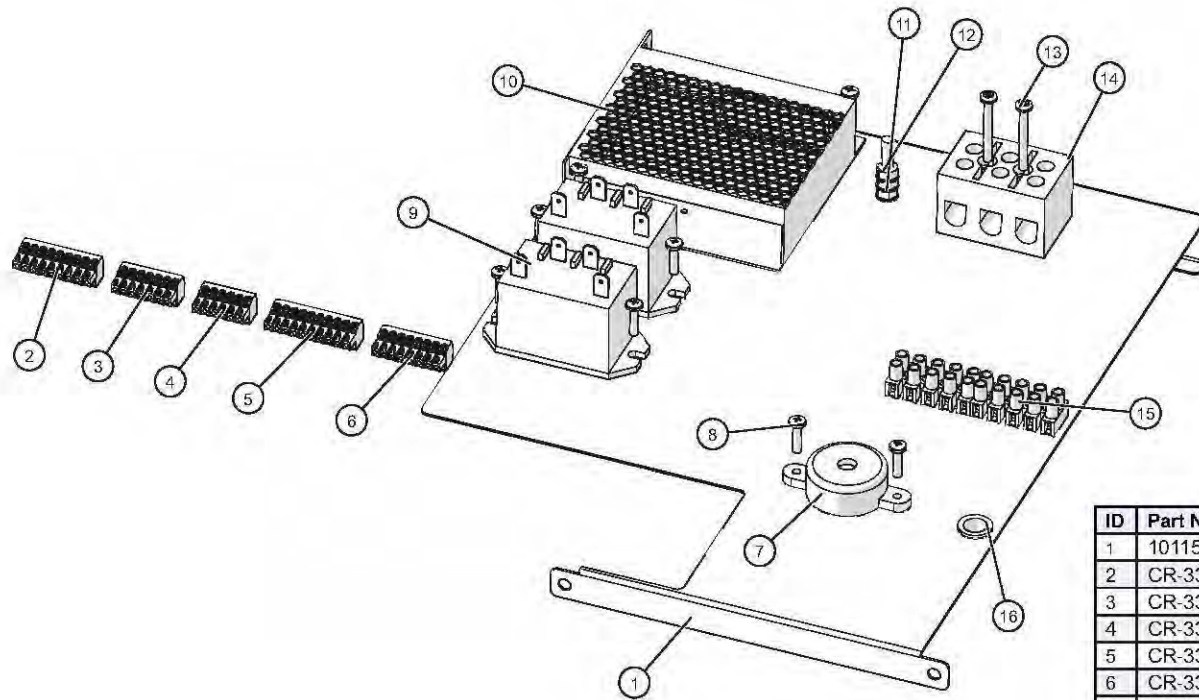

ID	Part No.	Description	Qty
1	1011531	WARMER SERIES ELEC CHASSIS	1
2	CR-33718	CONNECTOR 9 PIN	1
3	CR-33761	CONNECTOR, 7 PIN	1
4	CR-33762	CONNECTOR 6 PIN	1
5	CR-33717	CONNECTOR, 10 PIN	1
6	CR-33719	CONNECTOR 8 PIN	1
7	BP-3567	BEEPER, SOLID STATE, 1.5-20V	1
8	SC-22268	SCREW,PAN PHH, METRIC, MS	8
9	RL-33558	RELAY, SPST 30A @ 277 VAC 12VDC	2
10	BA-38586	BOARD, POWER SUPPLY, 12V	1
11	SC-38128	SCREW,PAN PH, METRIC, M5	1
12	NU-36234	NUT, M5, KEPS	3
13	SC-2365	SCREW,6-32X1-1/4,NC PHILLIPS	2
14	BK-3019	T-BLOCK	1
15	TM-33560	TERMINAL, STRIP,5 CIRCUIT,UL,VDE	2
16	BU-3006	1/2" HOLE BUSHING	1

Control Assembly, Single, Simple

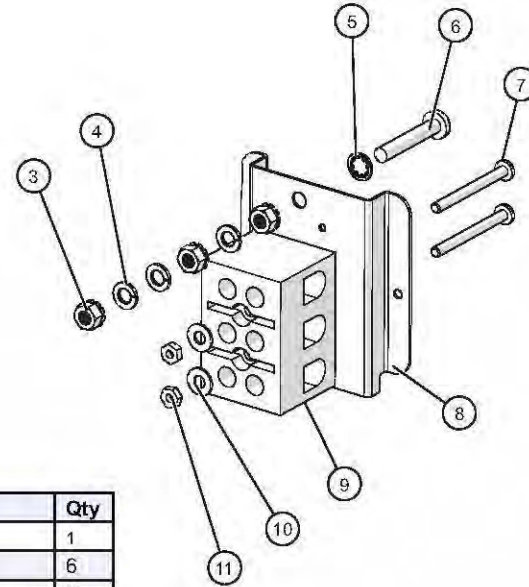
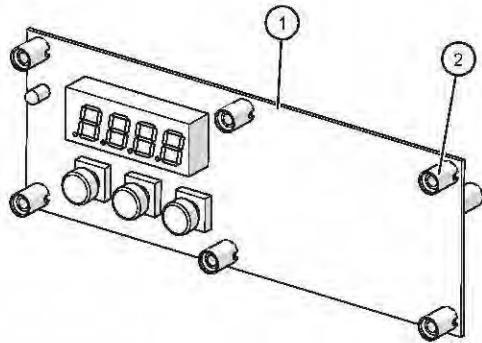

ID	Part No.	Description	Qty
1	CC-34970	LOW COST ELAN WARMER CONTROL	1
2	SP-29392	SPACER, SNAP-IN, 7/16"	6
3	NU-36234	NUT, M5, KEPS	3
4	WS-22301	WASHER, M5 SPLIT LOCK	3
5	WS-2467	WASHER, INT. LOCK	1
6	SC-38128	SCREW,PAN PH, METRIC, M5	1
7	SC-47136	SCREW,6-32X1-1/2" PAN	2
8	1033464	BRACKET,OFFSET,TERMINAL	1
9	BK-3019	T-BLOCK	1
10	WS-23424	WASHER, FLAT, #8, 18-8 SST	2
11	NU-2361	NUT, 6-32 HEX, S/S	2
12	5034795	WIRESET, SGL CAVITY WARMER (not shown)	1

Control Assembly, Double, Simple

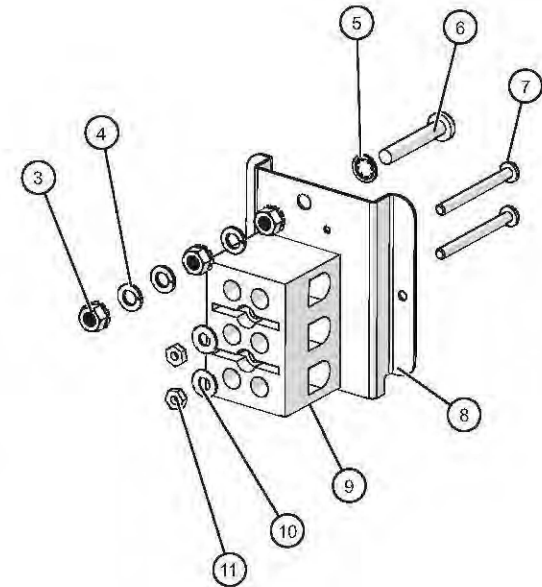
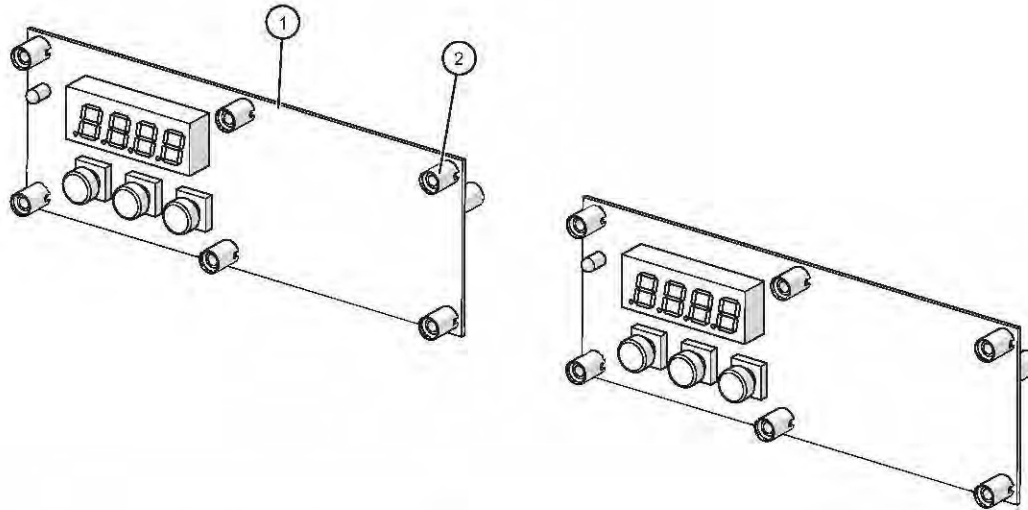

ID	Part No.	Description	Qty
1	CC-34970	LOW COST ELAN WARMER CONTROL	2
2	SP-29392	SPACER, SNAP-IN, 7/16"	12
3	NU-36234	NUT, M5, KEPS	3
4	WS-22301	WASHER, M5 SPLIT LOCK	3
5	WS-2467	WASHER, INT. LOCK	1
6	SC-38128	SCREW, PAN PH, METRIC, M5	1
7	SC-47136	SCREW, 6-32X1-1/2" PAN	2
8	1033464	BRACKET, OFFSET, TERMINAL	1
9	BK-3019	T-BLOCK	1
10	WS-23424	WASHER, FLAT, #8, 18-8 SST	2
11	NU-2361	NUT, 6-32 HEX, S/S	2
12	5034795	WIRESET, DBL CAVITY WARMER (not shown)	1

Control Assembly, Deluxe Electronic w/Probe

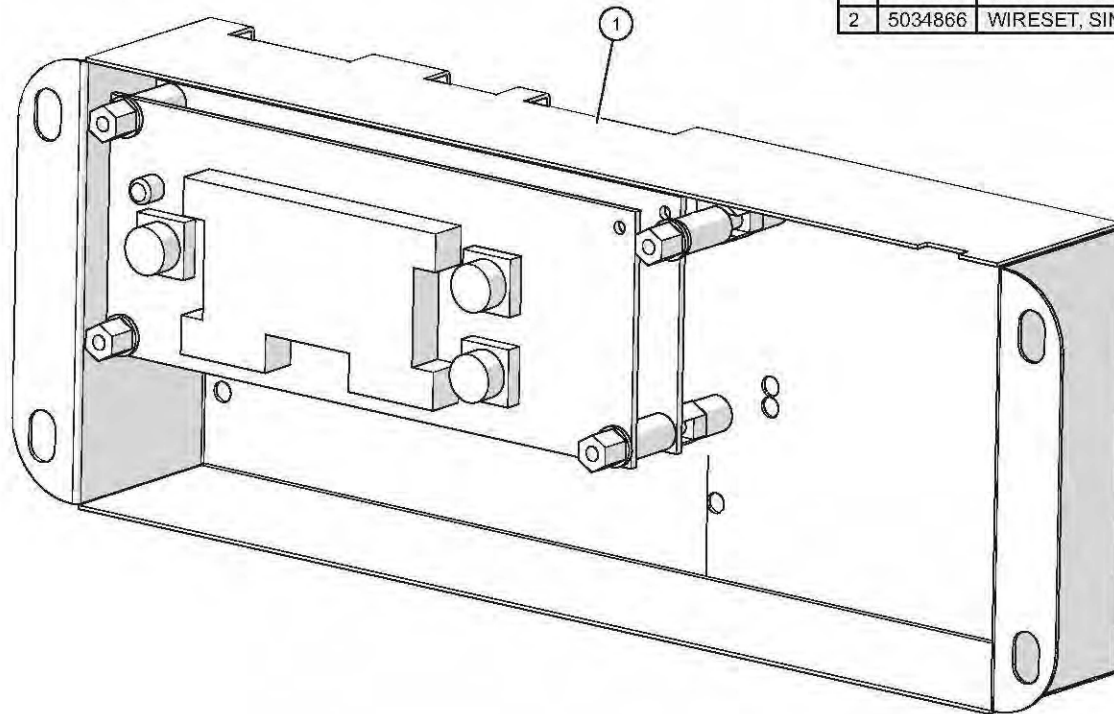

ID	Part No.	Description	Qty
1	5012946	SINGLE WARMER CONTROL	1
2	5034866	WIRESET, SINGLE CAVITY WARMER (not shown)	1

Control Assembly, Deluxe Electronic w/Timer

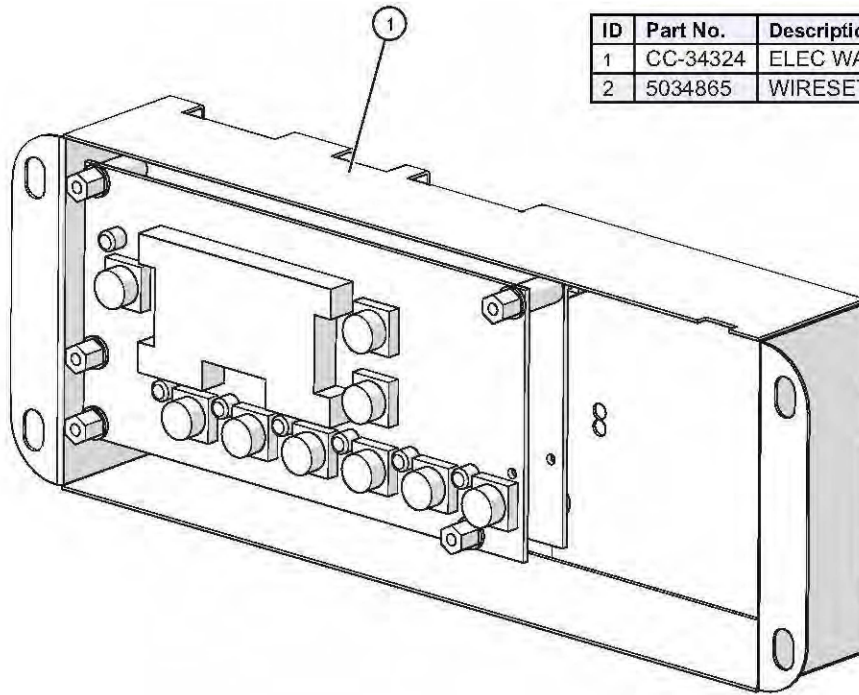

ID	Part No.	Description	Qty
1	CC-34324	ELEC WARMER CONTROL W/ TIMER	1
2	5034865	WIRESET, SINGLE CAVITY WARMER (not shown)	1

Control Assembly, Double, Deluxe w/Probe & Timer

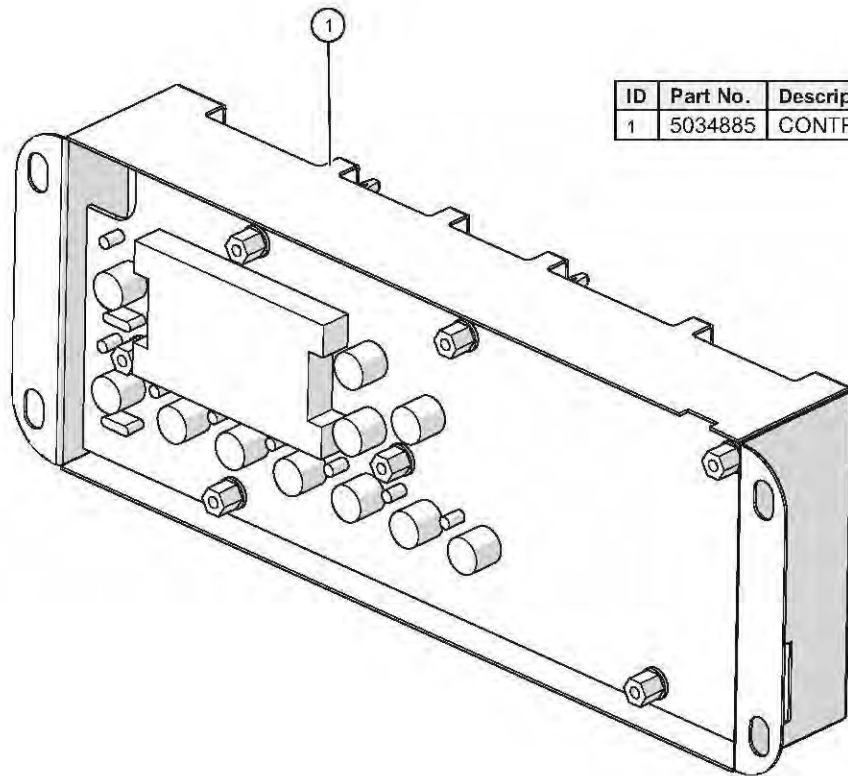

ID	Part No.	Description	Qty
1	5034885	CONTROL W/TIMERS, DUAL WARMER	1

1200-S Slab Door Package "A", Reach-In

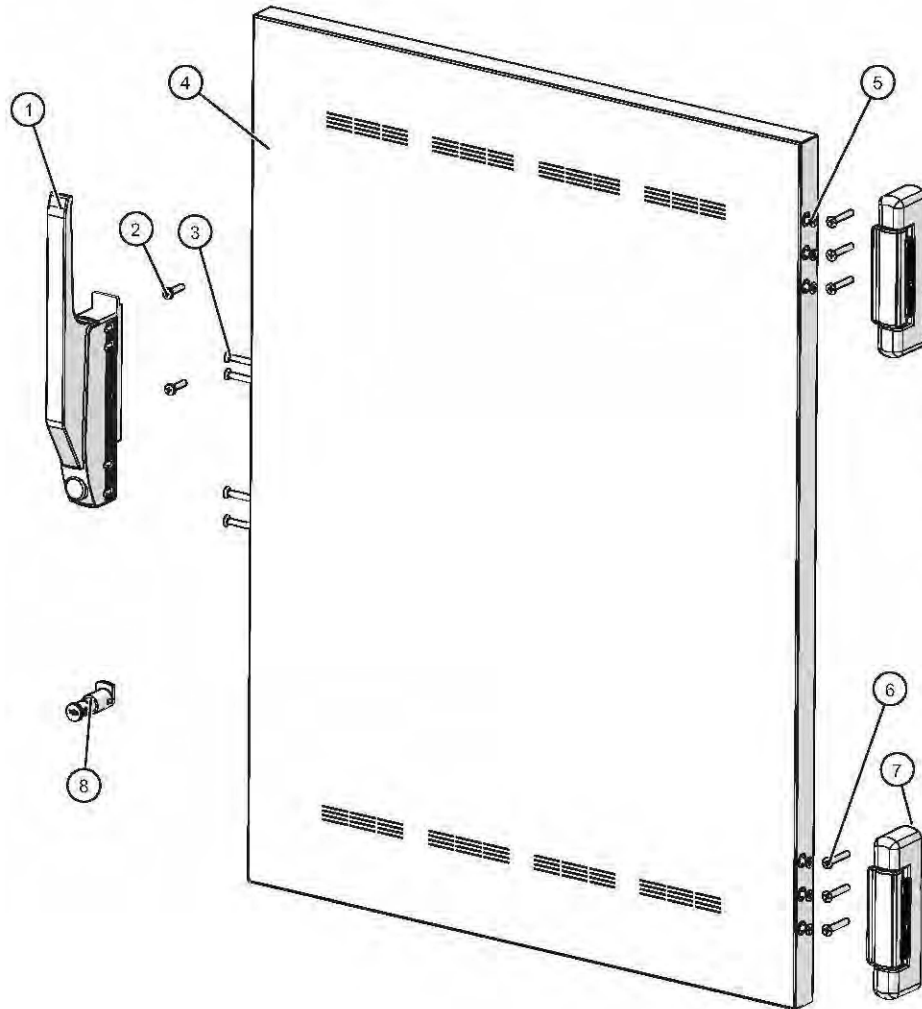

ID	Part No.	Description	Qty
1	HD-27080 (RH)	HANDLE, OFFSET MAG LATCH	1
2	SC-22779	SCREW, M5x0.8X20MM PAN	2
3	SC-35259	SCREW, M5x0.8X50MM FLAT	4
4	5012663	DOOR, ASSY, SLAB	1
5	SC-23868	SCREW, M5x0.8X20MM FLAT	6
6	SC-22853	SCREW, M5x0.8X30MM FLAT	6
7	HG-22338	HINGE, 1-3/8 OFFSET, PAIR, CHROME	1
8	LK-22567	LOCK, CYLINDER (optional)	1

1200-S Window Door Package "B", Reach-In

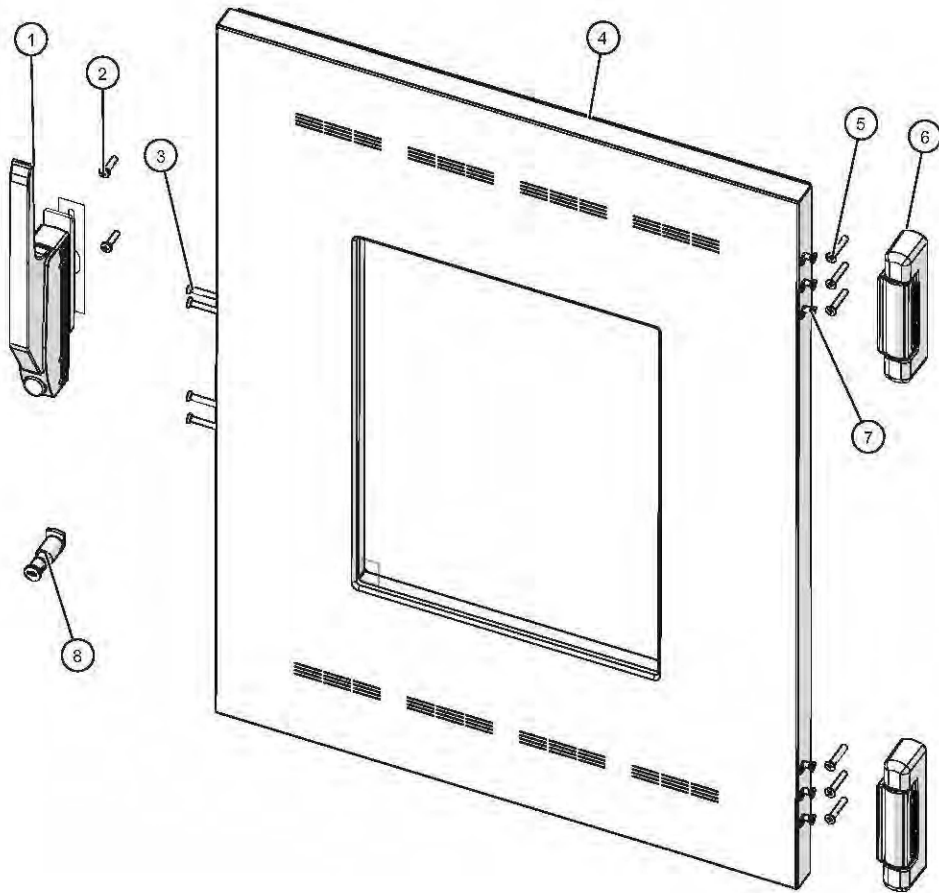

ID	Part No.	Description	Qty
1	HD-27080 (RH)	HANDLE, OFFSET MAG LATCH	1
2	SC-22779	SCREW, M5x0.8X20MM PAN	2
3	SC-35259	SCREW, M5x0.8X50MM FLAT	4
4	5012822	DOOR, ASSY, WINDOW	1
5	SC-22853	SCREW, M5x0.8X30MM FLAT	6
6	HG-22338	HINGE, 1-3/8 OFFSET, PAIR, CHROME	1
7	SC-23868	SCREW, M5x0.8X20MM FLAT	6
8	LK-22567	LOCK, CYLINDER (optional)	1

1200-S Slab Door Package "C", Pass-Thru

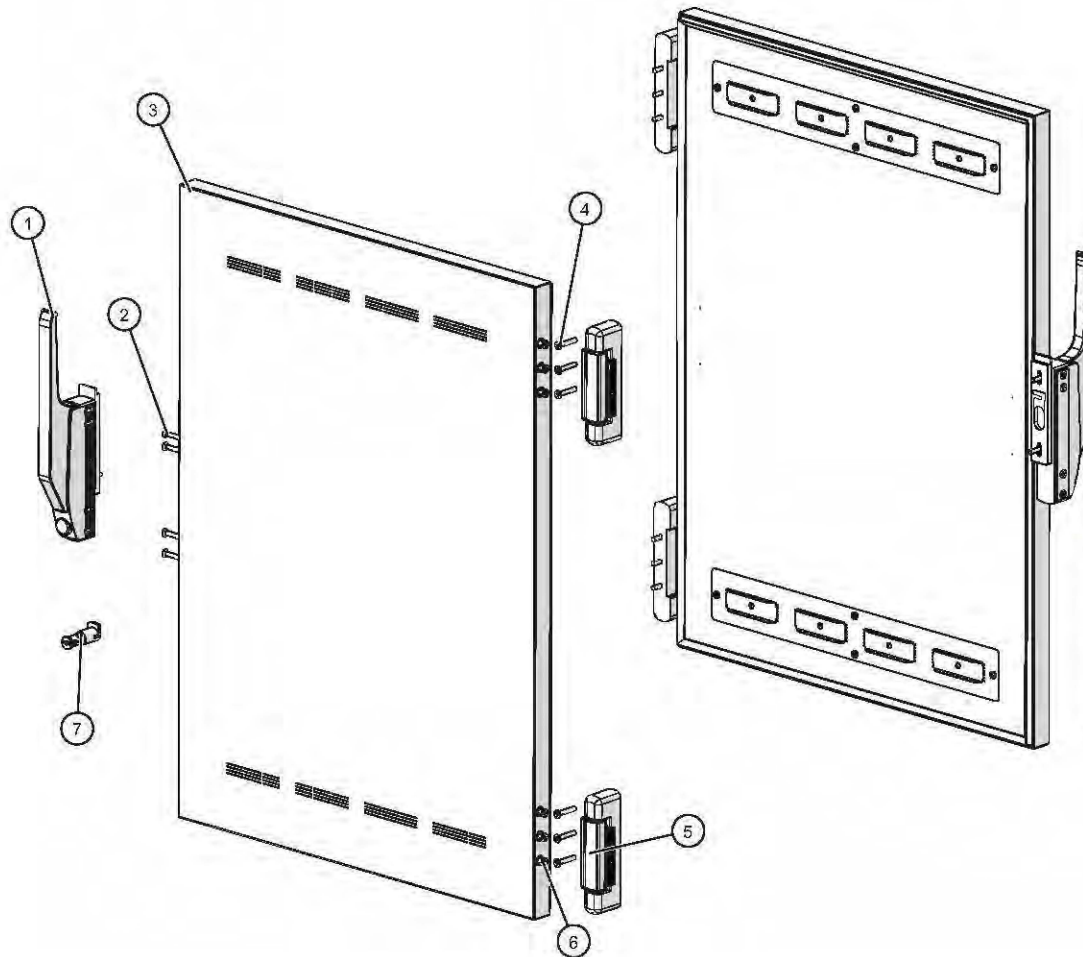

ID	Part No.	Description	Qty
1	HD-27080 (RH)	HANDLE, OFFSET MAG LATCH	2
2	SC-35259	SCREW, M5x0.8X50MM FLAT	8
3	5012663	DOOR, ASSY, SLAB	2
4	SC-22853	SCREW, M5x0.8X30MM FLAT	12
5	HG-22338	HINGE, 1-3/8 OFFSET, PAIR, CHROME	2
6	SC-23868	SCREW, M5x0.8X20MM FLAT	12
7	LK-22567	LOCK, CYLINDER (optional)	1

1200-S Window Door Package "D", Pass-Thru

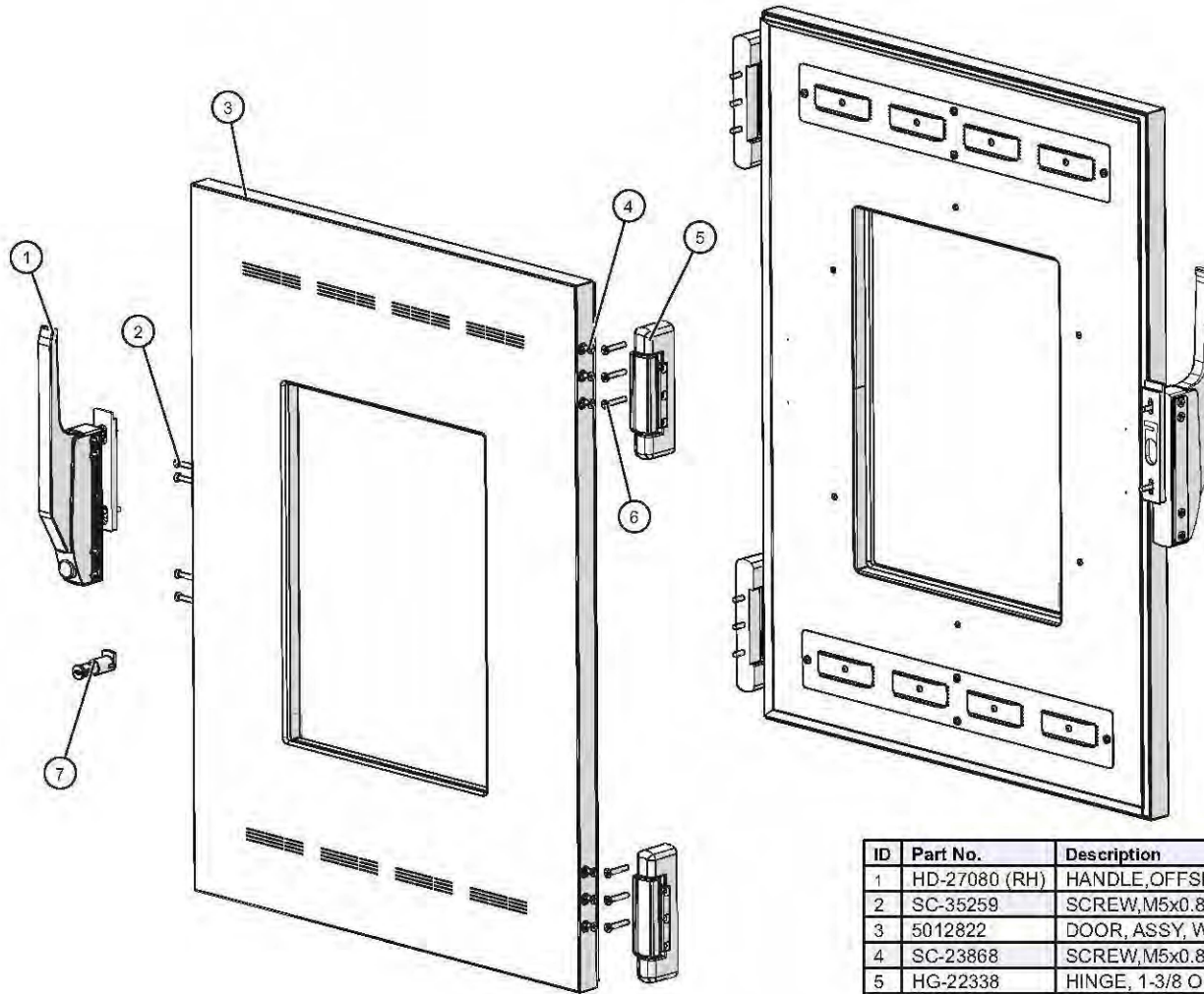

ID	Part No.	Description	Qty
1	HD-27080 (RH)	HANDLE, OFFSET MAG LATCH	1
2	SC-35259	SCREW, M5x0.8X50MM FLAT	8
3	5012822	DOOR, ASSY, WINDOW	2
4	SC-23868	SCREW, M5x0.8X20MM FLAT	6
5	HG-22338	HINGE, 1-3/8 OFFSET, PAIR, CHROME	1
6	SC-22853	SCREW, M5x0.8X30MM FLAT	12
7	LK-22567	LOCK, CYLINDER (optional)	1

1200-UP Slab Door Package "A", Reach-In

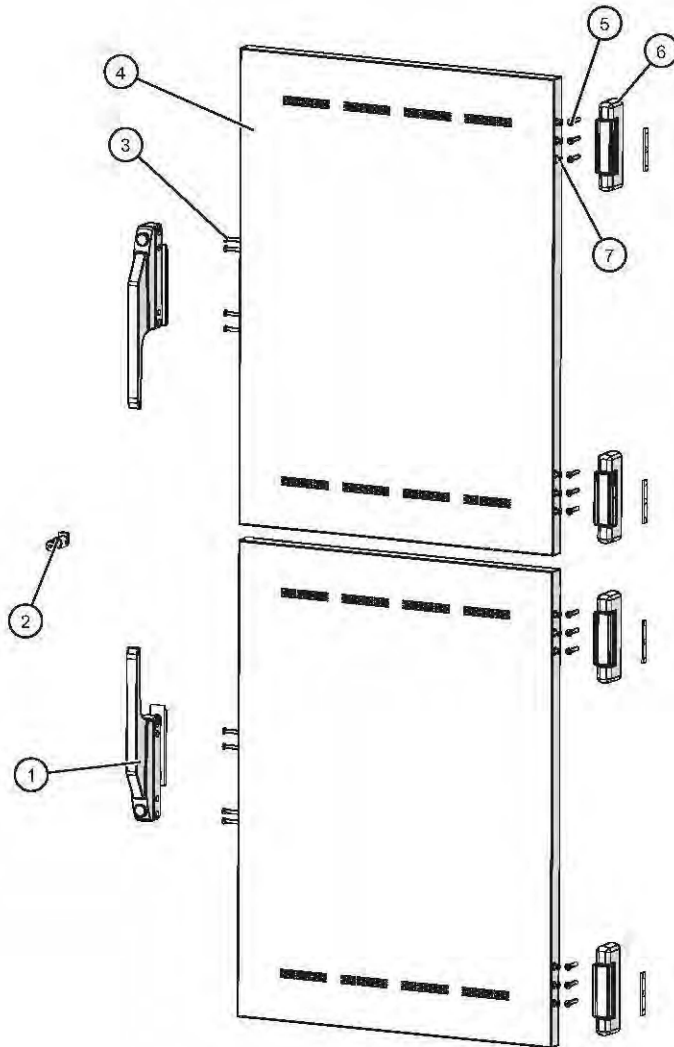

ID	Part No.	Description	Qty
1	HD-27080	HANDLE, OFFSET MAG LATCH	2
2	LK-22567	LOCK, CYLINDER (optional)	1
3	SC-35259	SCREW, M5x0.8X50MM FLAT	8
4	5012663	DOOR, ASSY, SLAB	2
5	SC-22853	SCREW, M5x0.8X30MM FLAT	12
6	HG-22338	HINGE, 1-3/8 OFFSET, PAIR, CHROME	2
7	SC-23868	SCREW, M5x0.8X20MM FLAT	8

1200-UP Window Door Package "B", Reach-In

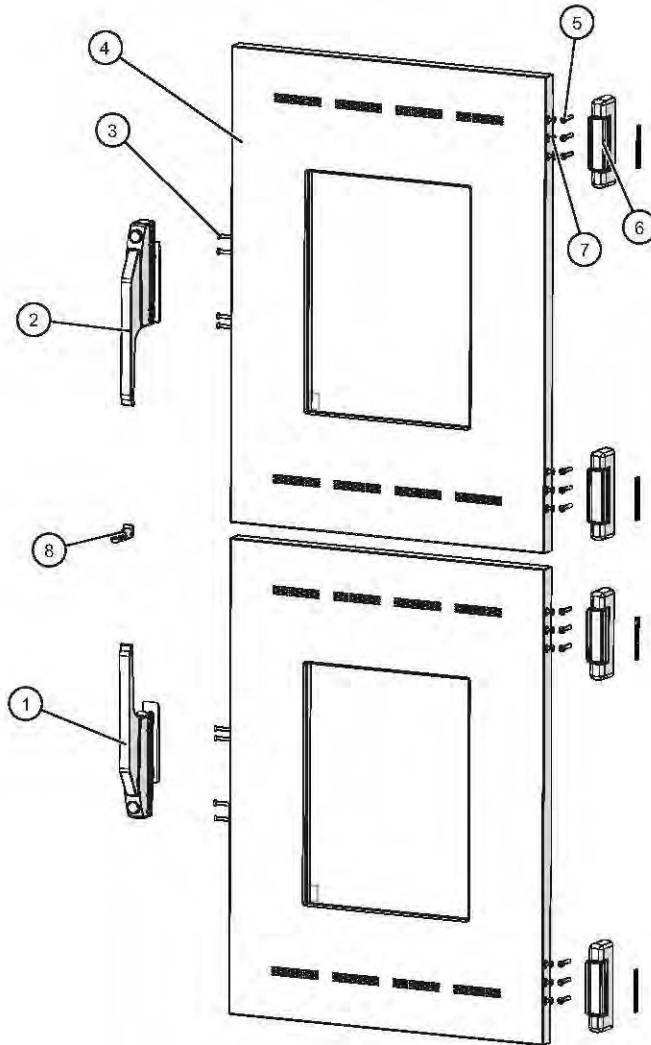

ID	Part No.	Description	Qty
1	HD-27080 (RH)	HANDLE,OFFSET MAG LATCH	1
2	HD-27080 (LH)	HANDLE,OFFSET MAG LATCH	1
3	SC-35259	SCREW,M5x0.8X50MM FLAT	5
4	5012822	DOOR, ASSY, WINDOW	2
5	SC-22853	SCREW,M5x0.8X30MM FLAT	12
6	HG-22338	HINGE, 1-3/8 OFFSET, PAIR, CHROME	2
7	SC-23868	SCREW,M5x0.8X20MM FLAT	12
8	LK-22567	LOCK,CYLINDER (optional)	1

1200-UP Slab Door Package "C", Pass-Thru

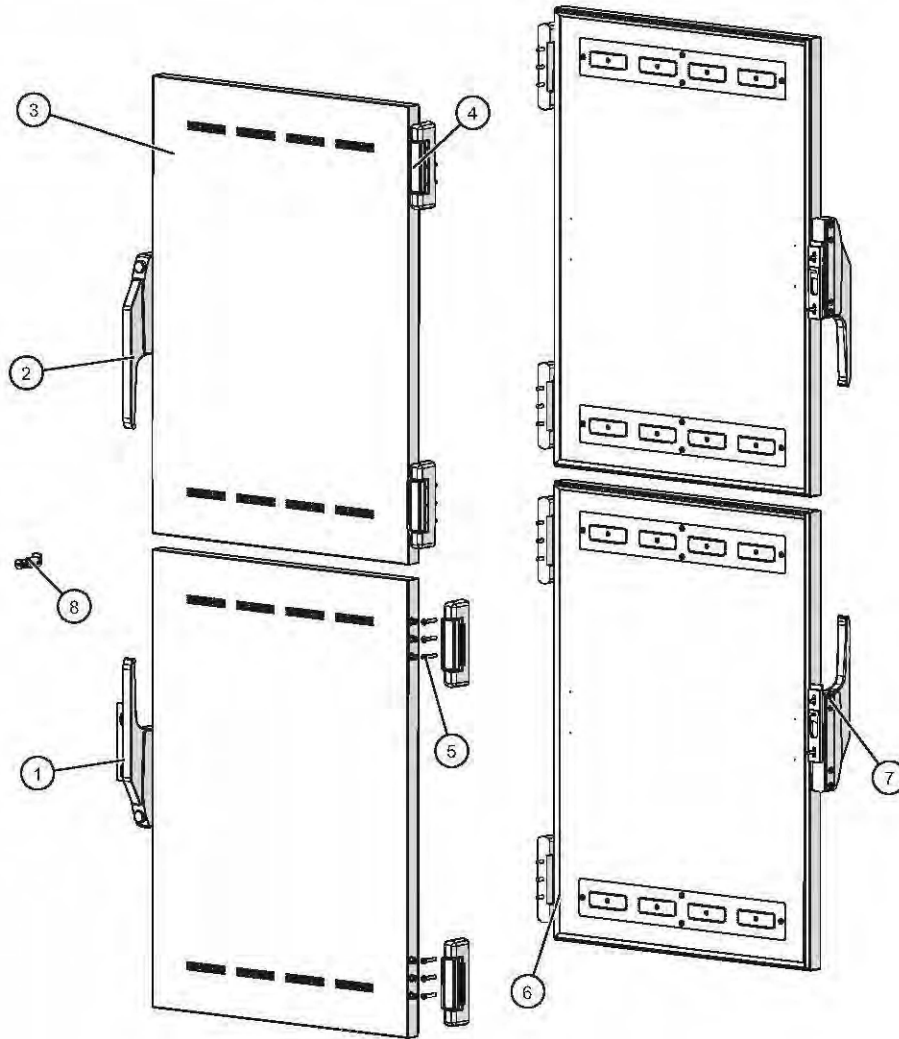

ID	Part No.	Description	Qty
1	HD-27080 (RH)	HANDLE, OFFSET MAG LATCH	2
2	HD-27080 (LH)	HANDLE, OFFSET MAG LATCH	2
3	5012663	DOOR, ASSY, SLAB	4
4	HG-22338	HINGE, 1-3/8 OFFSET, PAIR, CHROME	4
5	SC-22853	SCREW, M5x0.8X30MM FLAT	24
6	SC-23868	SCREW, M5x0.8X20MM FLAT	24
7	SC-35259	SCREW, M5x0.8X50MM FLAT	12
8	LK-22567	LOCK, CYLINDER (optional)	1

1200-UP Window Door Package "D", Pass-Thru

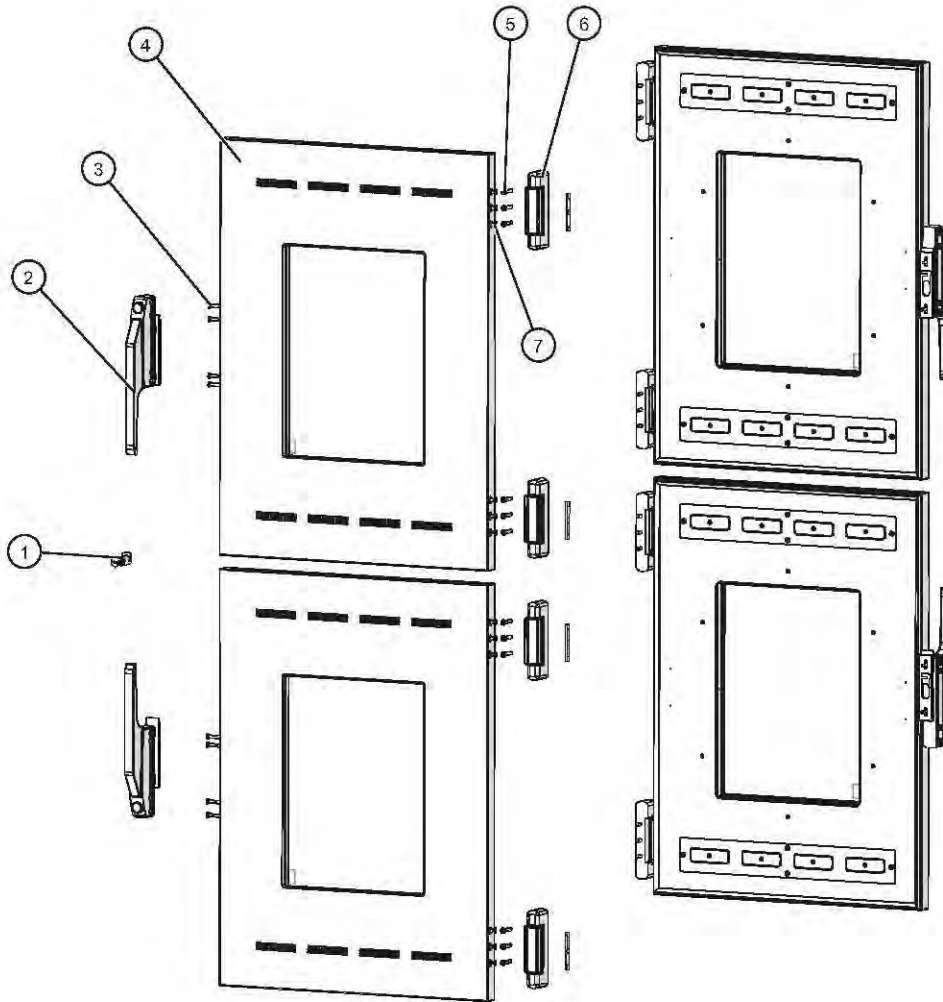

ID	Part No.	Description	Qty
1	LK-22567	LOCK, CYLINDER (optional)	1
2	HD-27080	HANDLE, OFFSET MAG LATCH	4
3	SC-35259	SCREW, M5x0.8X50MM FLAT	16
4	5012822	DOOR, ASSY, WINDOW	4
5	SC-22853	SCREW, M5x0.8X30MM FLAT	24
6	HG-22338	HINGE, 1-3/8 OFFSET, PAIR, CHROME	4
7	SC-23868	SCREW, M5x0.8X20MM FLAT	10

1200-S Side Rack Package, Chrome Shelves

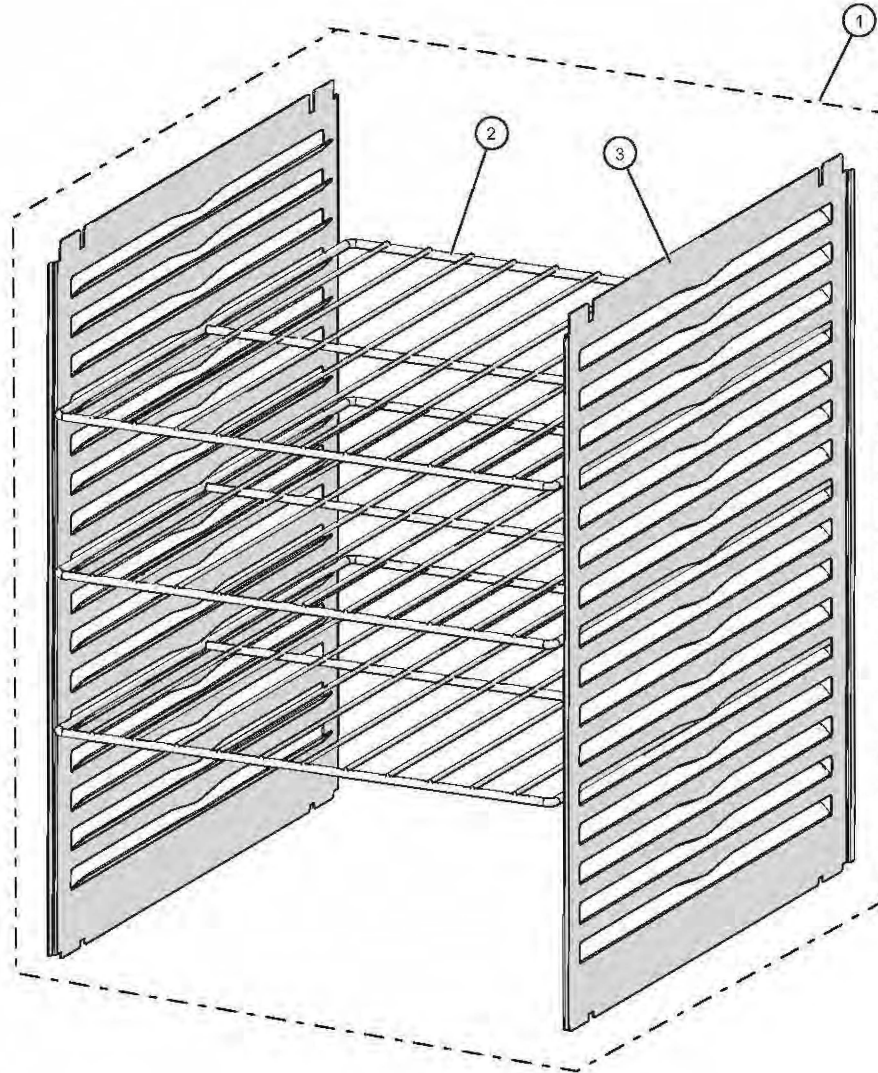

ID	Part No.	Description	Qty
1	5014570	1200-S SIDE RACK PACKAGE	1
2	SH-2733	SHELF, NICKEL CHROME, 1200-SR	3
3	1011743	INTERNATIONAL SIDE RACK	2

1200-S Side Rack Package, Stainless Shelves

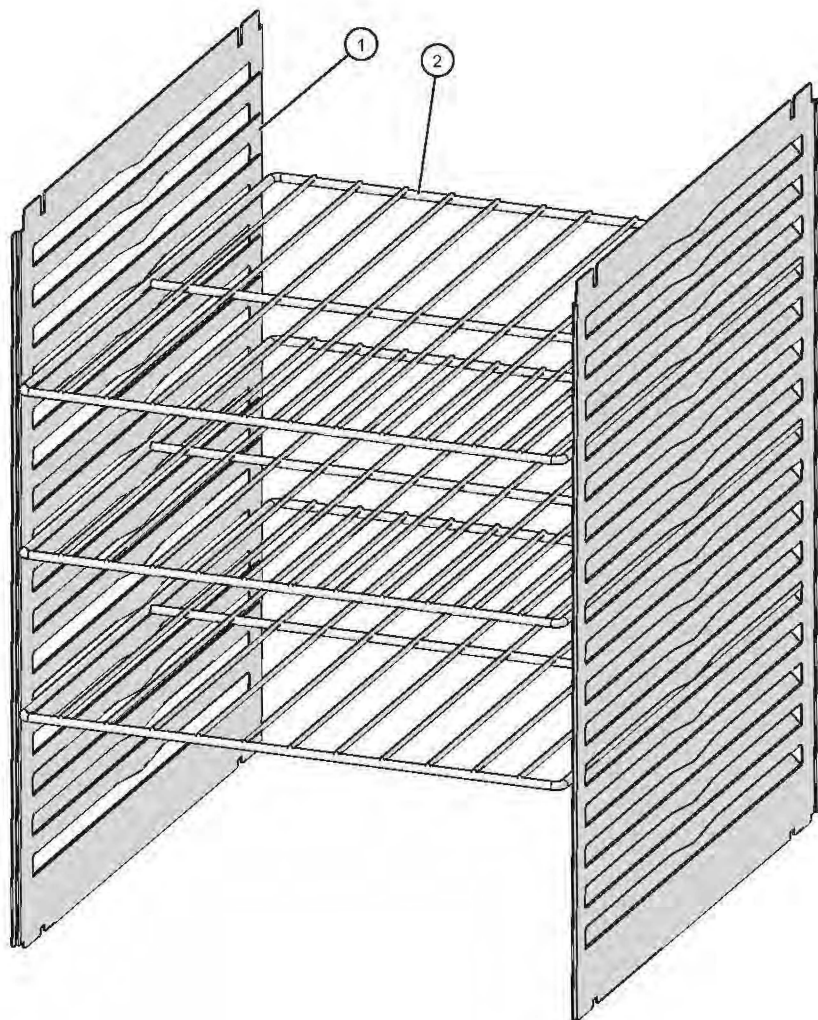

ID	Part No.	Description	Qty
1	1011743	INTERNATIONAL SIDE RACK	2
2	SH-23738	SHELF,S/S,1200-S,S/PT,UP,UPS	3

1200-UP Side Rack Package, Chrome Shelves

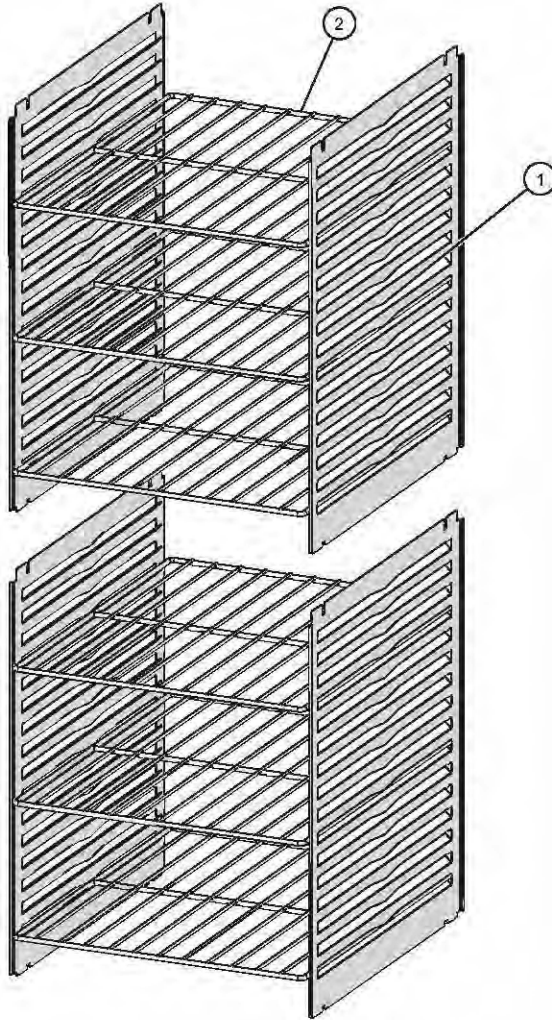

ID	Part No.	Description	Qty
1	1011743	INTERNATIONAL SIDE RACK	4
2	SH-2733	SHELF, NICKEL CHROME, 1200-SR	6

Cordset/Ferrule Assembly, NEMA 5-15P

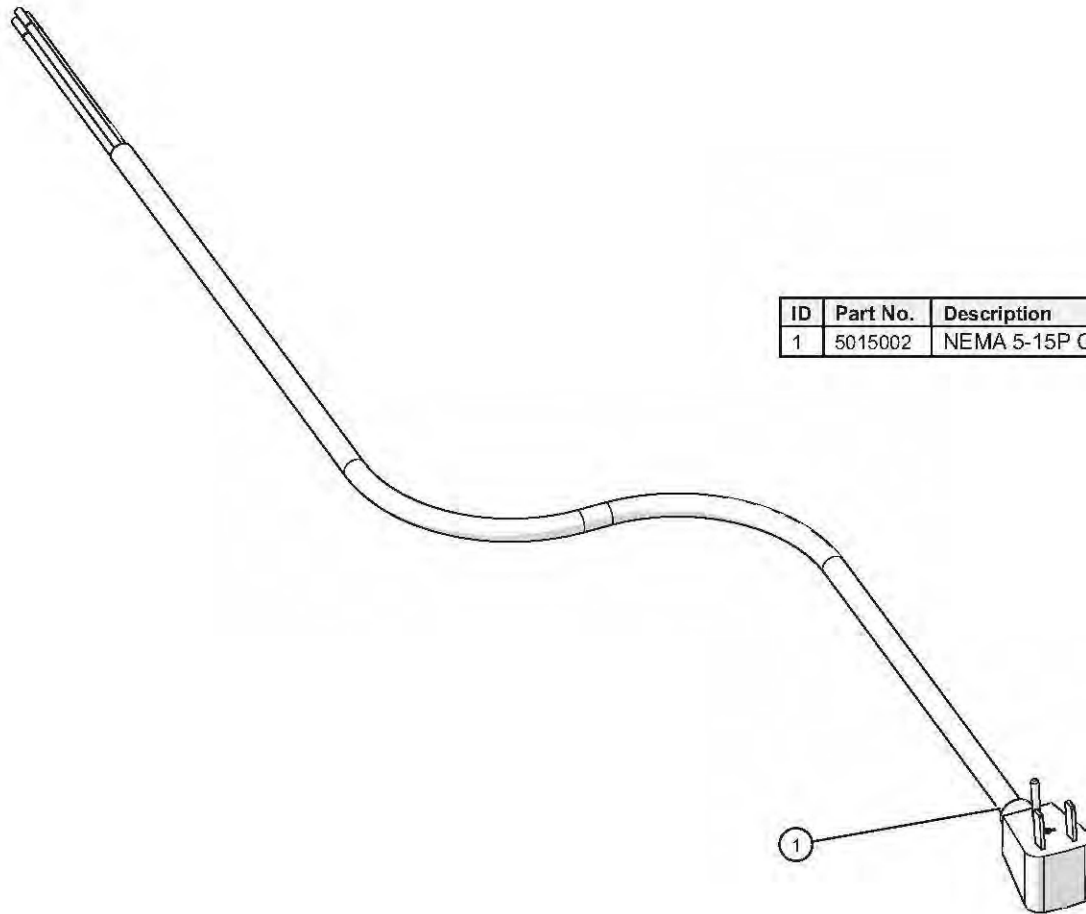

ID	Part No.	Description
1	5015002	NEMA 5-15P CORDSET FERRULE ASSEMBLY

Cordset/Ferrule Assembly, NEMA 5-20P

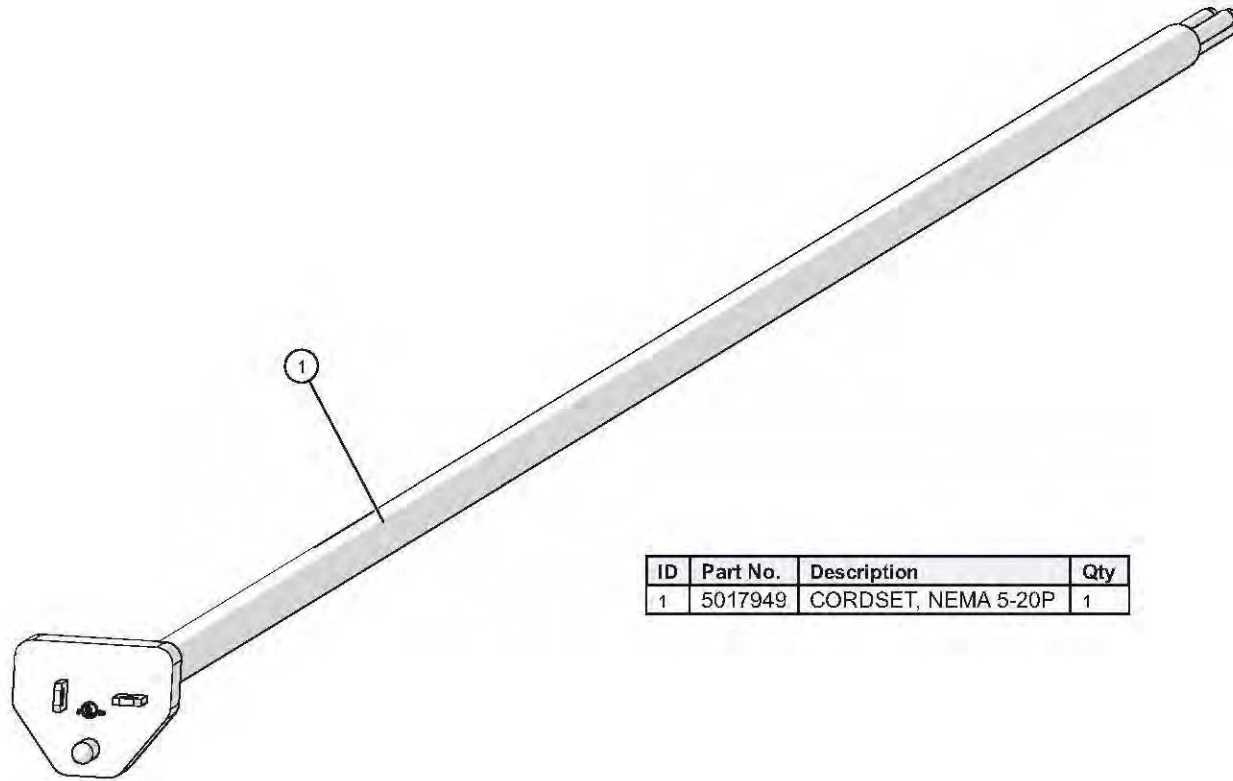

ID	Part No.	Description	Qty
1	5017949	CORDSET, NEMA 5-20P	1

CORD, 12/3 WITH FERRULES, 12'

Cord, 12/3 with Ferrules, 12'

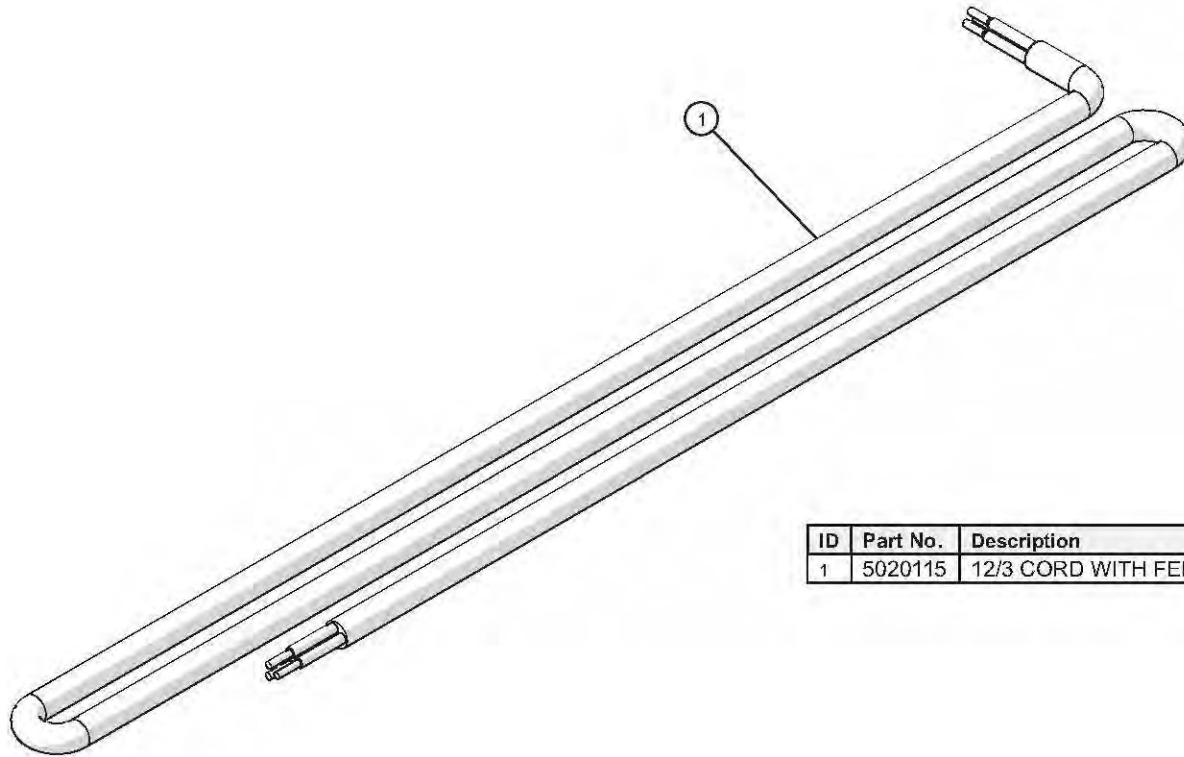

ID	Part No.	Description	Qty
1	5020115	12/3 CORD WITH FERRULES, 12'	1

Cordset/Ferrule Assembly, SAA AS 3112-16P

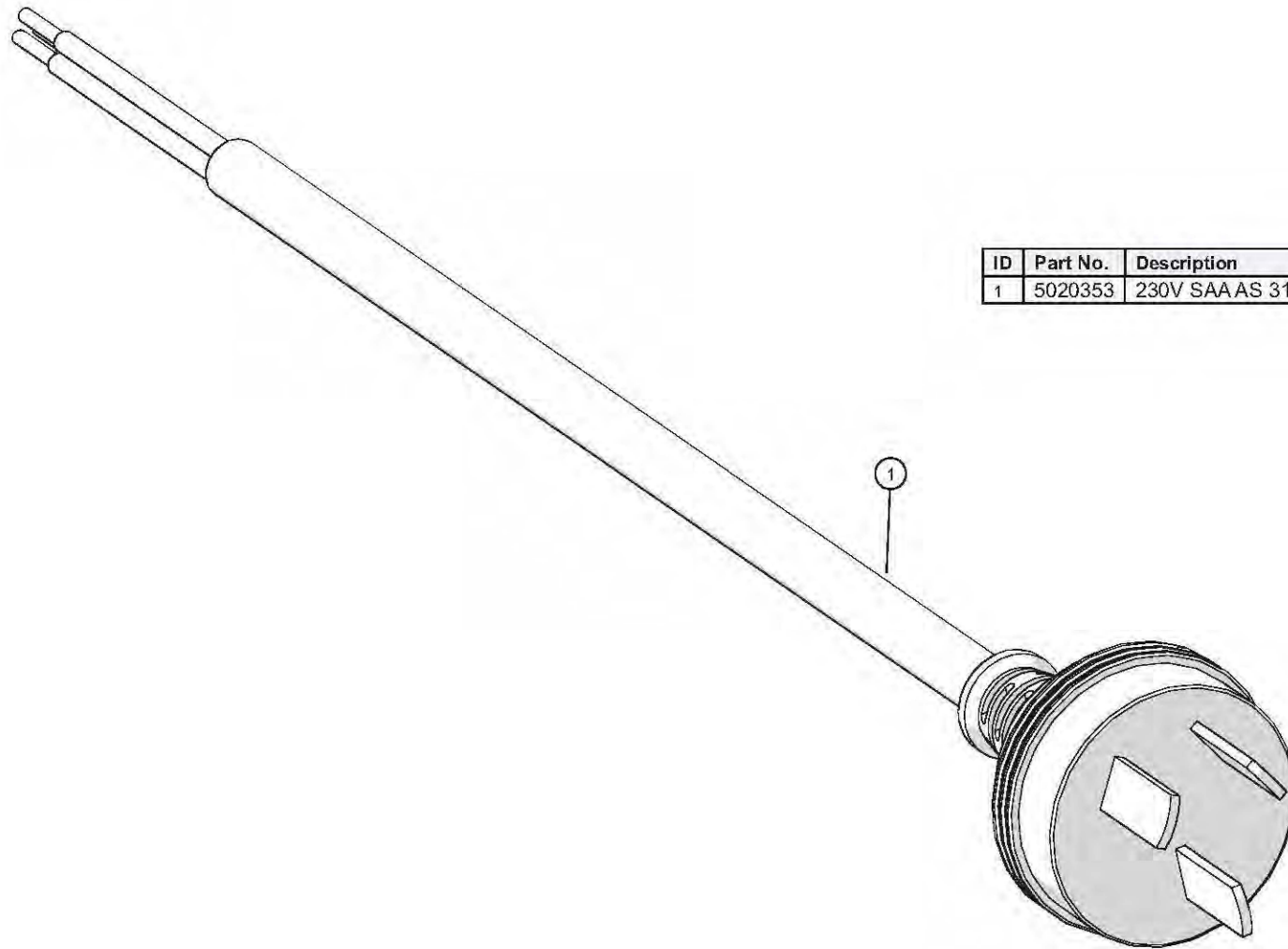

ID	Part No.	Description	Qty
1	5020353	230V SAAAS 3112-16P CORDSET	1

Cordset Assembly, AS/NZS 3112

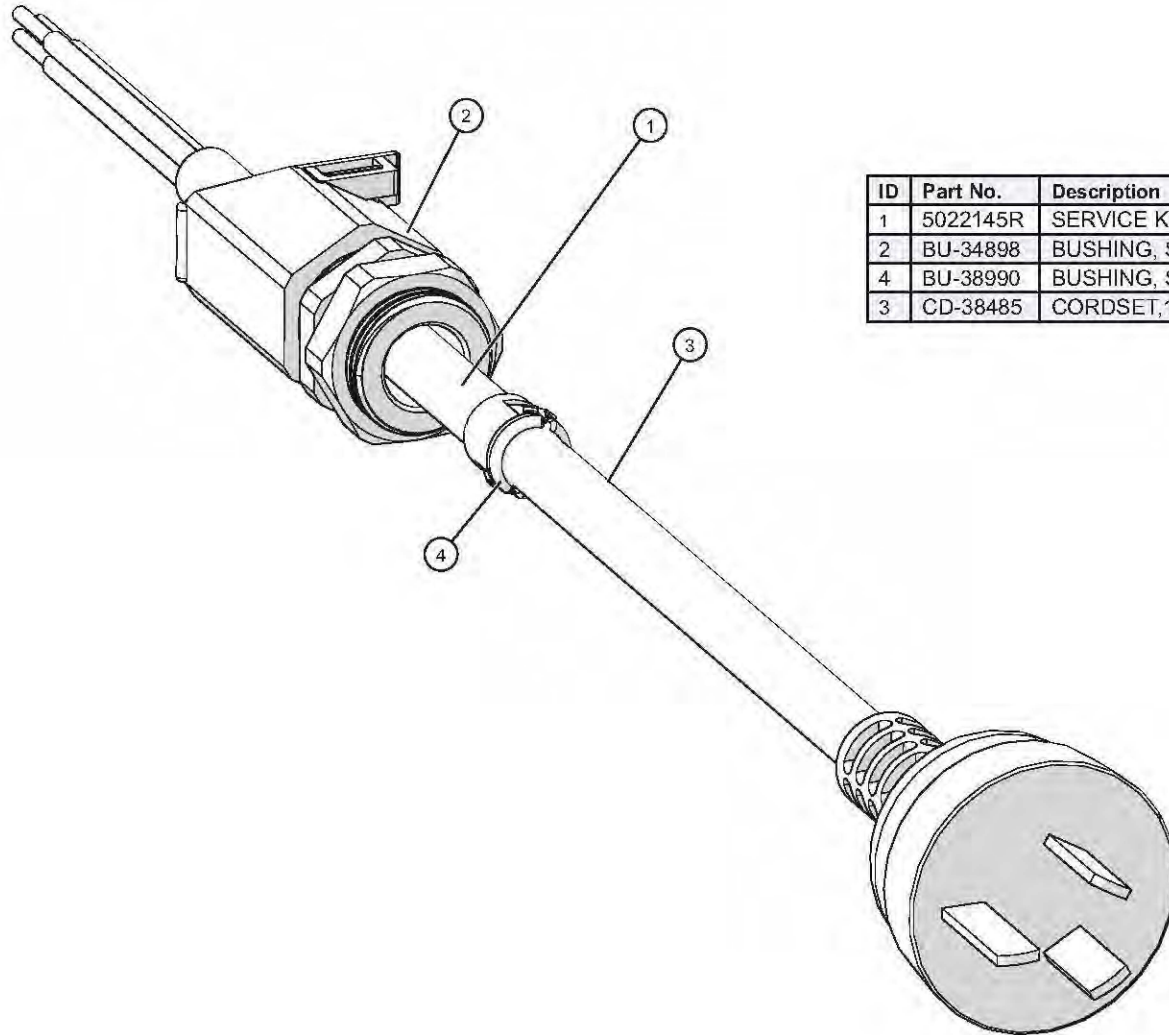

ID	Part No.	Description	Qty
1	5022145R	SERVICE KIT, CORDSET,10A-250V	1
2	BU-34898	BUSHING, STRAIN RELIEF, 90°, BLK	1
4	BU-38990	BUSHING, SNUB, 3/16" CABLE	1
3	CD-38485	CORDSET,10A-250V	1

Cordset Assembly, AS/NZS 3112 2000

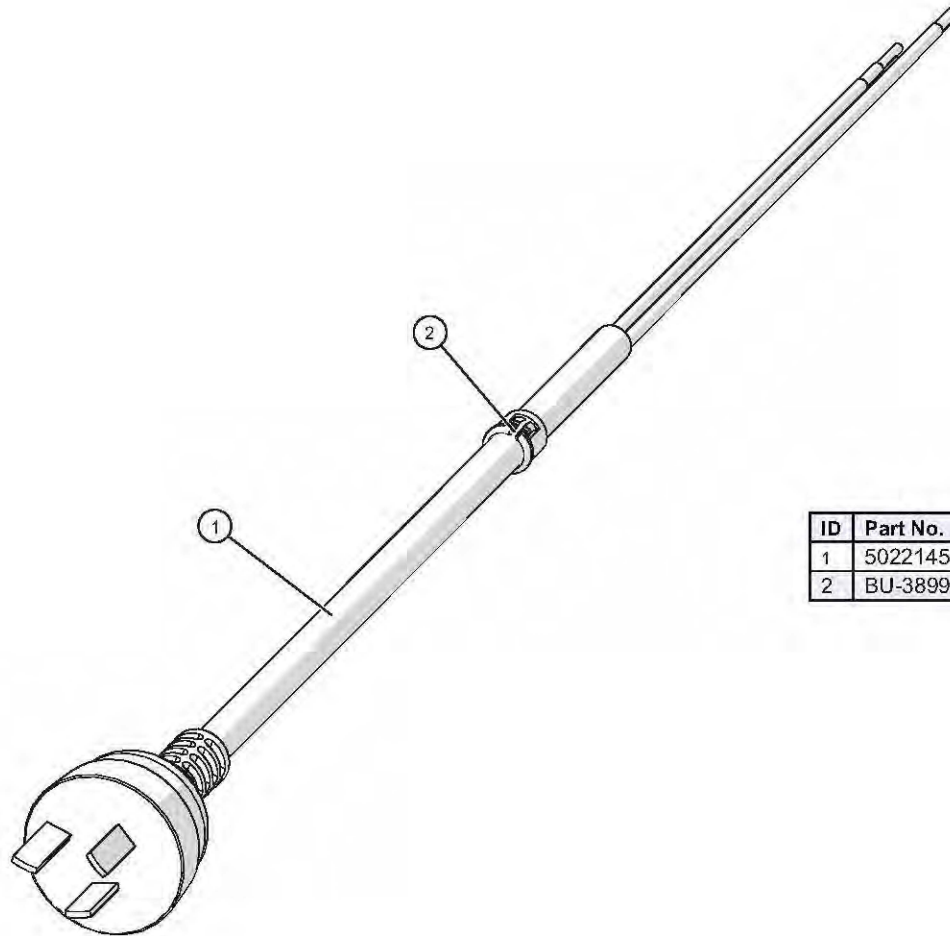

ID	Part No.	Description	Qty
1	5022145	CORDSET,10A-250V,AS/NZS 3112:2000	1
2	BU-38990	BUSHING, SNUB, 3/16" CABLE	1

Cordset/Ferrule Assembly, NEMA 6-15P

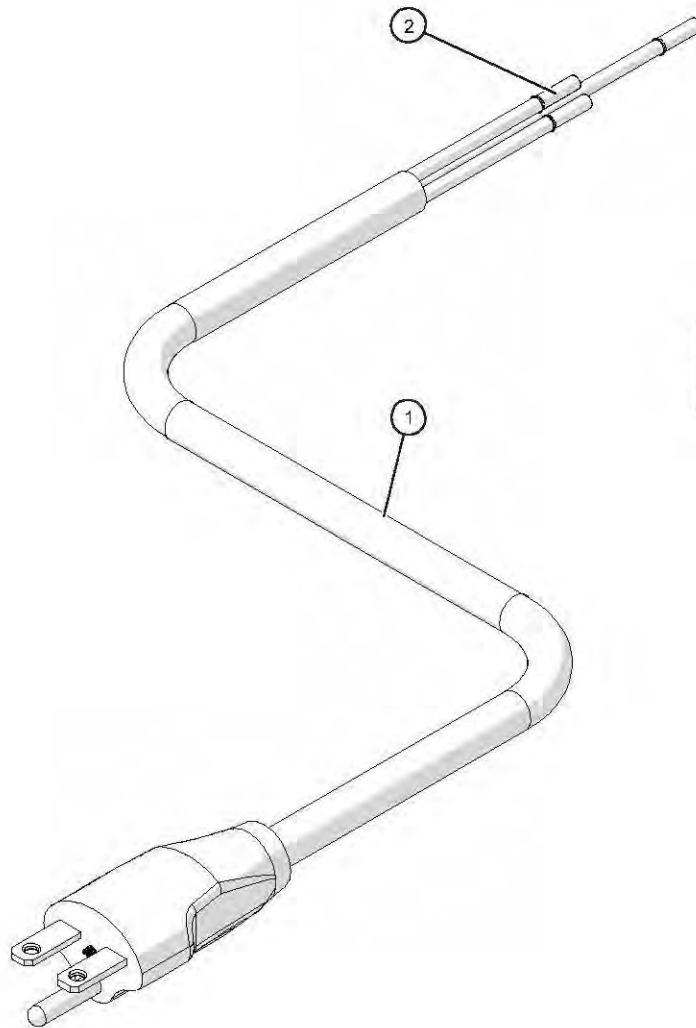

ID	Part No.	Description
1	CD-3551	CORDSET, 14/3 SJTO, 250V
2	CR-34829	CONNECTOR, #14 FERRULE

Cordset/Ferrule Assembly, CEE-7/7

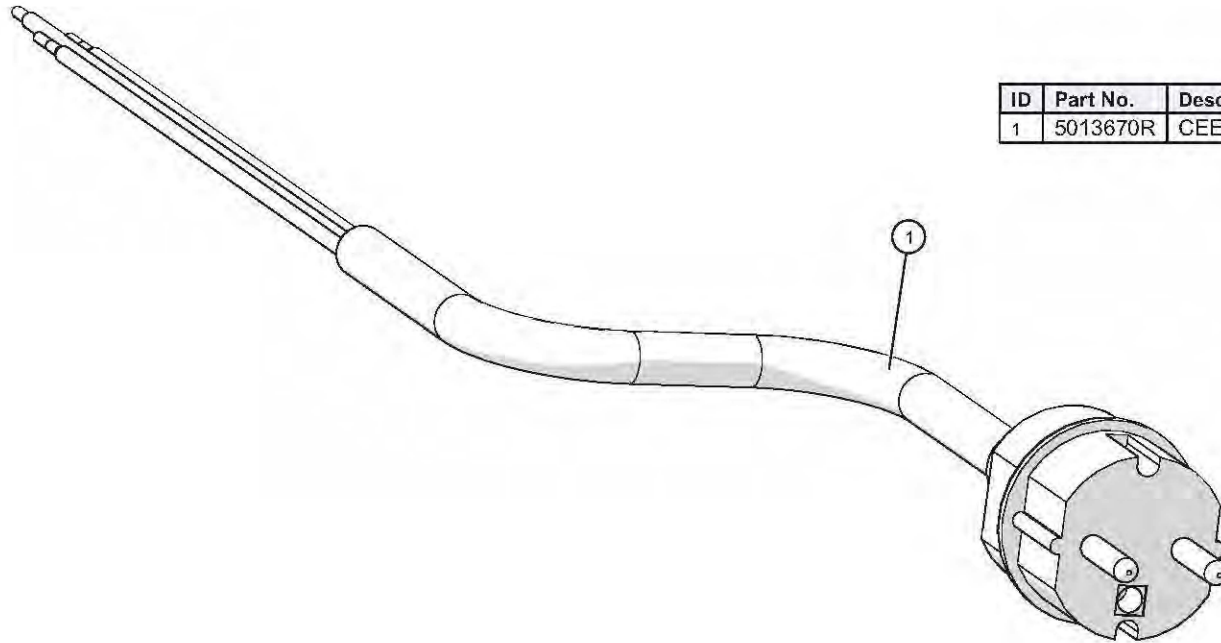

ID	Part No.	Description	Qty
1	5013670R	CEE 7/7 CORDSET FERRULE ASSEMB	1

Cordset/Ferrule Assembly, BS 1363

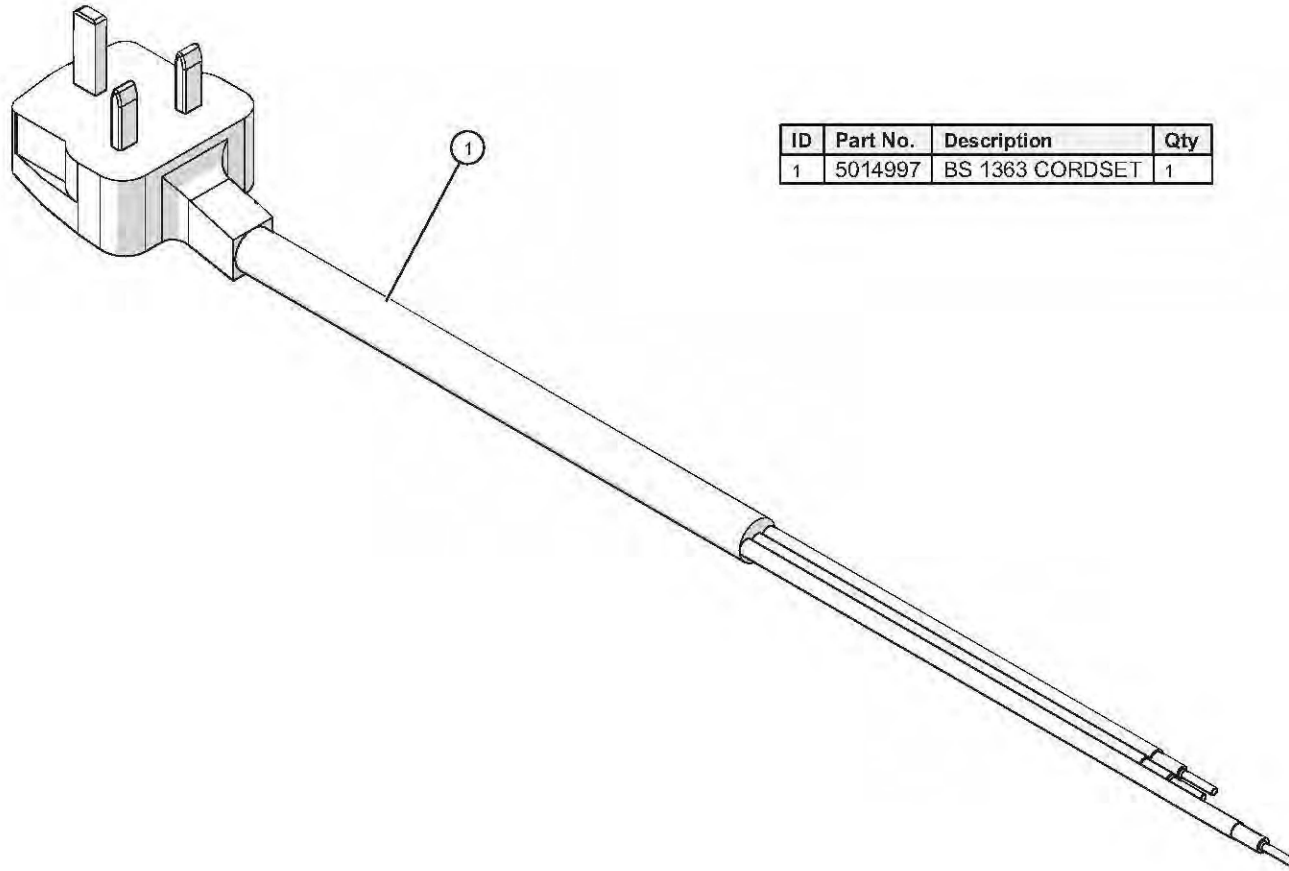

Cordset/Ferrule Assembly, CH2-16P

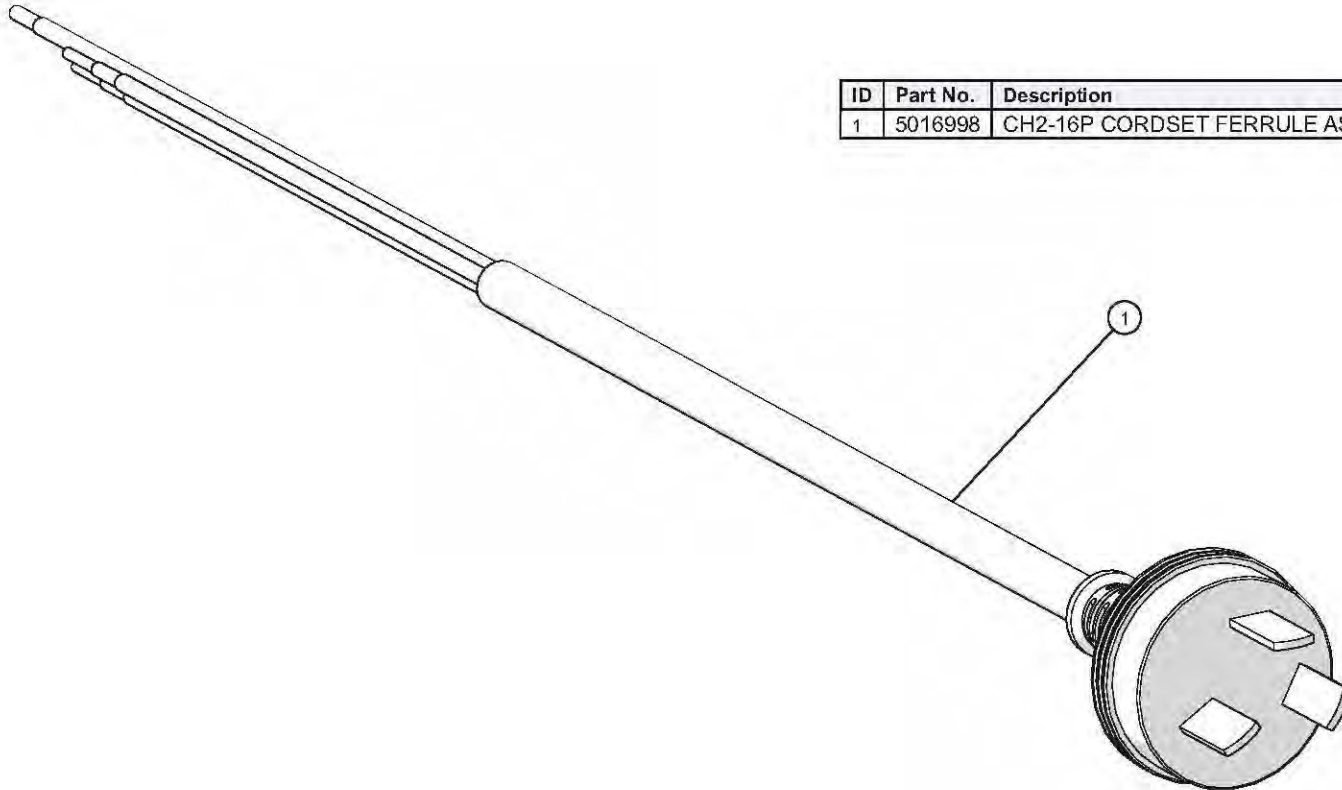

ID	Part No.	Description	Qty
1	5016998	CH2-16P CORDSET FERRULE ASSEMBLY	1

Probe Assembly, Deluxe

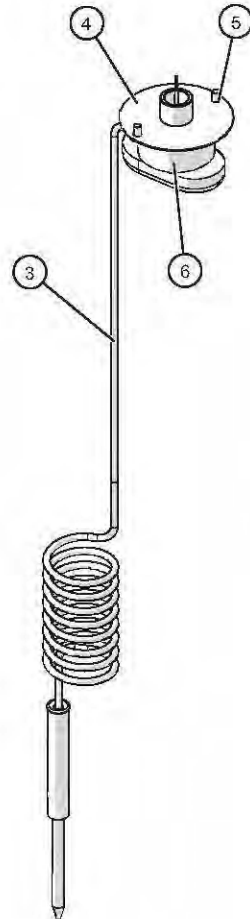
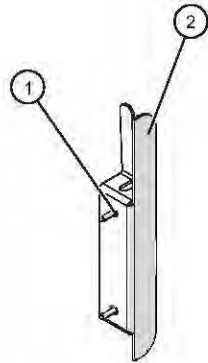

ID	Part No.	Description	Qty
1	RI-27108	RIVET, SEALED	2
2	13239	PROBE HOLDER, TH	1
3	PR-36065	PROBE, QUICK CONNECT, PT100	1
4	5009712	PROBE COVER WELDMENT	1
5	SC-22271	M4 X 6MM PH PAN HD M/S .7	2
6	PR-34705	PROBE, RECEPTACLE, 600MM WIRE	1

Caster Package, 2-1/2"

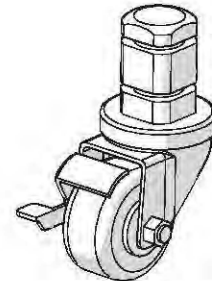
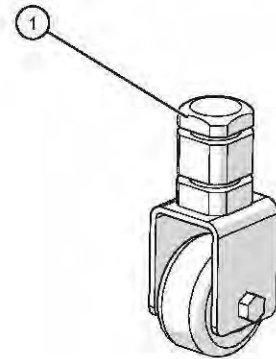
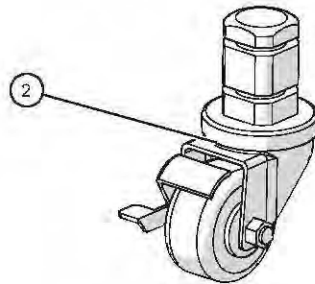

ID	Part No.	Description	Qty
1	CS-38265	CASTER, RIGID 2.5", 1.5" STEM	2
2	CS-38264	CASTER, SWIVEL 2.5", 1.5" STEM	2

Caster Package, 3-1/2"

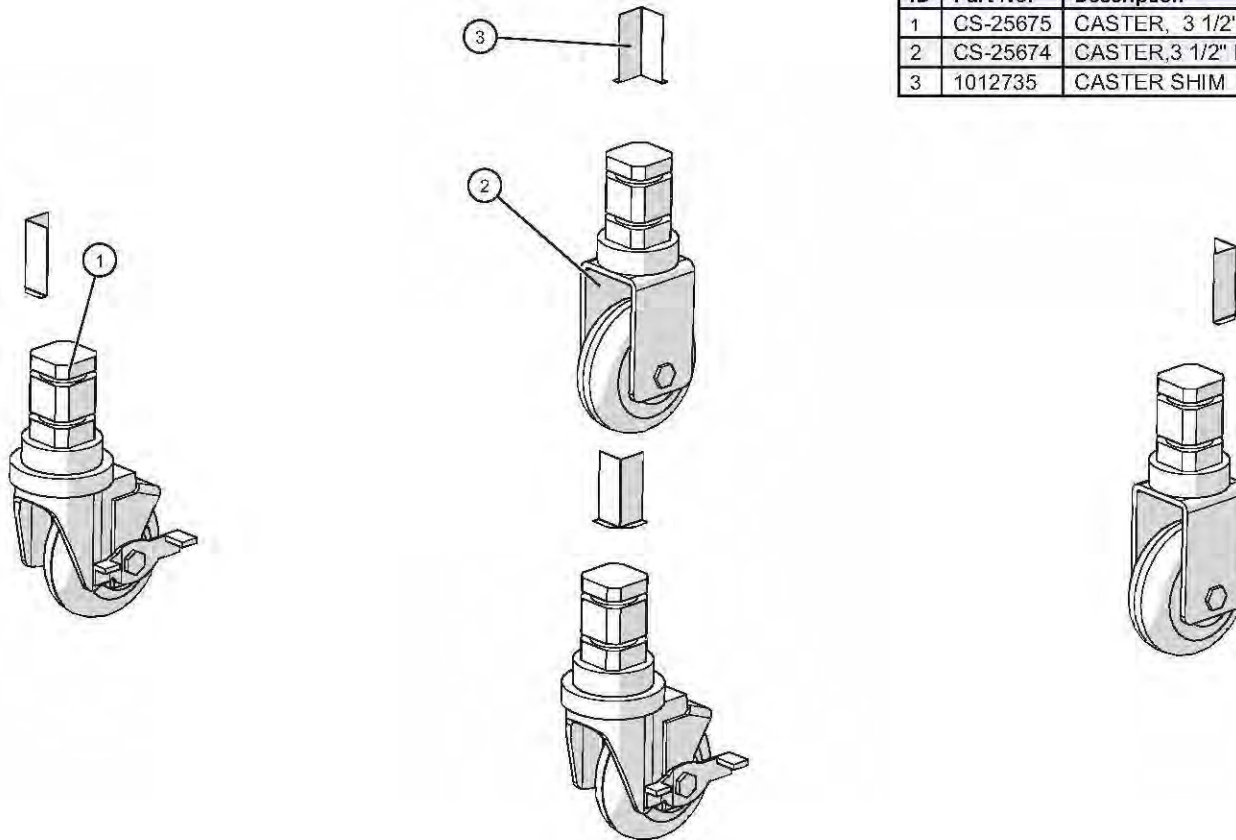

ID	Part No.	Description	Qty
1	CS-25675	CASTER, 3 1/2" SWIVEL W/ BRAKE	2
2	CS-25674	CASTER, 3 1/2" RIGID	2
3	1012735	CASTER SHIM	4

Caster Package, 5"

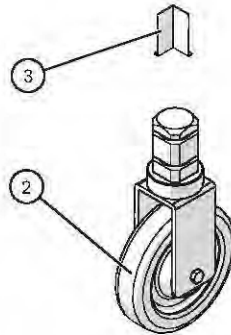
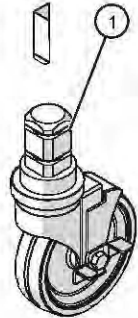

ID	Part No.	Description	Qty
1	CS-24875	CASTER, 1.5" STEM, 5" SWIV WHL	2
2	CS-24874	CASTER, 5" RIGID, 1.5" STEM	2
3	1012735	CASTER SHIM	4



Caster Package, 5" (all swivel)

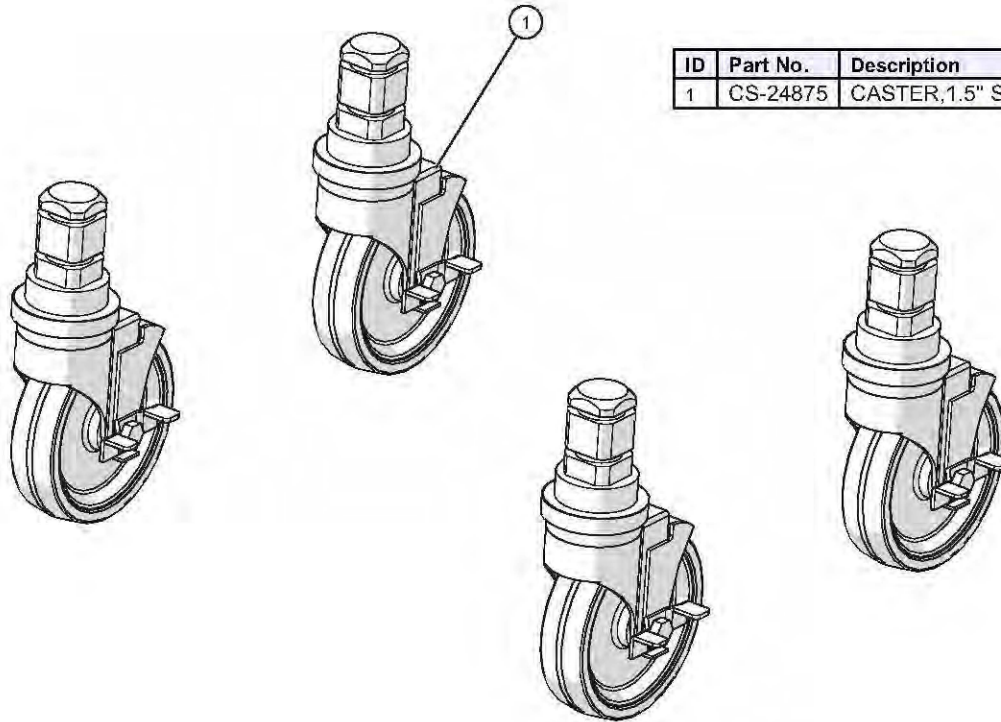

ID	Part No.	Description
1	CS-24875	CASTER, 1.5" STEM, 5" SWIV WHL

Flanged Leg Option, 6"

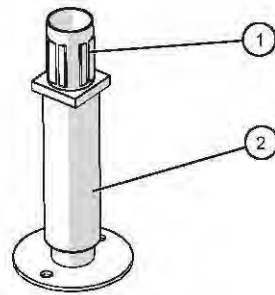

ID	Part No.	Description	Qty
2	LG-23067	6" LEG W/ ADJUSTABLE FLANGED FOOT	4
1	LG-37094	LEG, ADJUST, FOOTING	4

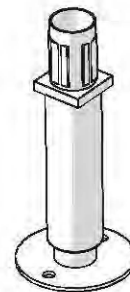
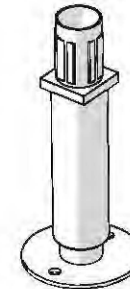
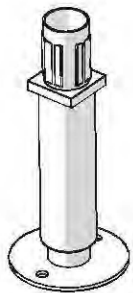

Plug Assembly, Tether Bracket

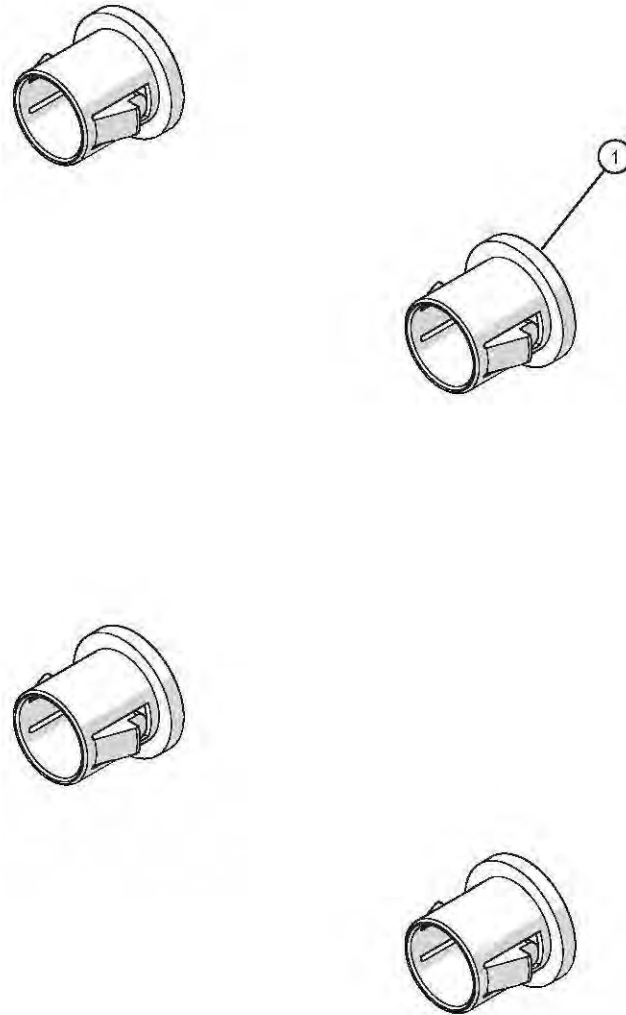

ID	Part No.	Description
1	PG-28439	PLUG, DOME, .187" HOLE



ALTO-SHAAM.

Menomonee Falls, WI U.S.A.

Phone 800-558-8744 | +1-262-251-3800 | alto-shaam.com

ASIA

Shanghai, China
Phone +86-21-6173-0336

AUSTRALIA

Brisbane, Queensland
Phone 800-558-8744

CANADA

Concord, Ontario Canada
Toll Free Phone 866-577-4484
Phone +1-905-660-6781

FRANCE

Aix en Provence, France
Phone +33[0]4-88-78-21-73

GMBH

Bochum, Germany
Phone +49 [0]234 298798-0

ITALY

Padua, Italy
Phone +39 3476073504

INDIA

Pune, India
Phone +91 9657516999

MEXICO

Phone +52 1 477-717-3108

MIDDLE EAST & AFRICA

Dubai, UAE
Phone +971-4-321-9712

CENTRAL & SOUTH AMERICA

Miami, FL USA
Phone +1 954-655-5727