

ALTO-SHAAM, INC.

OPERATION CARE MANUAL

TYPE: OVEN, LOW TEMPERATURE COOKING
AND HOLDING, ELECTRONIC

MODELS:

AS-2000 • CH-200

HALO HEAT COOK/HOLD/SERVE SYSTEMS BY ALTO-SHAAM

W164 N9221 Water Street • P.O. Box 450 • Menomonee Falls, Wisconsin 53051-0450 • U.S.A.

(414) 251-3800 • TOLL FREE (800) 558-8744 • CANADA (800) 341-2474

TELEX: (ITT) 4311070 Altsham

FAX: (414) 251-7067



ALTO-SHAAM, INC.
ELECTRONIC LOW TEMPERATURE COOKING & HOLDING OVEN

INDEX

	<u>PAGE</u>		<u>PAGE</u>
<u>GENERAL INFORMATION</u>		<u>REPAIR and SERVICE</u>	
UNPACKING and SET-UP	1	OVEN TEMPERATURE and CALIBRATION.....	9
ELECTRICAL INSTALLATION.....	1	CHECKING/REPLACING PROBE or SENSORS.....	9
START-UP	1	CHECKING/REPLACING CONTROL COOLING FAN	9
GENERAL CHARACTERISTICS	2	CONTROL COOLING FAN THERMOSTAT.....	9
OUTSIDE DIMENSIONS.....	2	BEEPER.....	9
PAN CAPACITIES	2	CIRCUIT BREAKER POWER SWITCH.....	9
OPTIONS & ACCESSORIES.....	2	CHECKING/REPLACING HEATING ELEMENT.....	9
CONTROL FUNCTIONS.....	2	CONTROL REPLACEMENT PROCEDURES.....	9
CONTROL PANEL	3	CHANGING FROM °F MODE TO °C MODE	9
<u>OPERATING PROCEDURES</u>		SERVICE VIEW PARTS LIST	10
AUTOMATIC COOK & HOLD.....	4	SERVICE VIEW AS-2000 • CH-200.....	11
MANUAL HOLD.....	4	WIRING DIAGRAM 125V, 60 Hz.....	12
RESET	4	WIRING DIAGRAM 200—240V, 50/60 HZ	13
SUGGESTED COOKING GUIDELINES.....	5	STACKING HARDWARE MOUNTING INSTRUCTIONS	14
<u>CARE and MAINTENANCE</u>		TRANSPORTATION DAMAGE and CLAIMS.....	15
EQUIPMENT CARE.....	6	ALTO-SHAAM WARRANTY	15
CONFIDENCE TEST.....	6		
SANITATION GUIDELINES.....	7		
HOLDING GUIDELINES.....	7		
HOLDING TEMPERATURE RANGE.....	7		
TROUBLE SHOOTING CHECK LIST.....	8		

HALO HEAT COOK/HOLD/SERVE SYSTEMS BY ALTO-SHAAM

W164 N9221 Water Street • P. O. Box 450 • Menomonee Falls, Wisconsin 53051-0450 • U.S.A.
 (414)251-3800 • (800)558-8744 • Canada (800)341-2474 • Telex (ITT) 4311070 Altsham • FAX (414)251-7067

ALTO-SHAAM, INC. OPERATION & CARE MANUAL • AS-2000 and CH-200

UNPACKING and SET-UP

The Alto-Shaam Electronic Cooking and Holding Oven has been thoroughly tested, checked for calibration, and inspected to insure only the highest quality oven is provided. When you receive your oven, check for any possible shipping damage and report it at once to the delivering carrier.

The oven, complete with unattached items and accessories, may be delivered in one or more packages. Check to insure that all the following items have been received as standard with each unit:

- 1 ea. Drip Pan#1062
- 2 ea. Oven Side Racks#SR-2303
- 3 ea. Wire Shelves#SH-2324
- 2 ea. Casters, Rigid#CS-2025
- 2 ea. Casters, Swivel with Brake ...#CS-2026
- 16 ea. Caster Mounting Screws#SC-2351

Save all the information and instructions packed inside the oven. Complete and return the warranty card to the factory as soon as possible to insure prompt service in the event of a warranty parts and labor claim.

The 5" (127-mm) casters or optional 6" (152.4-mm) legs must be installed on the oven before use. For the best service, the oven should be installed level. The oven should NOT be installed in any area where it may be affected by steam, grease, dripping water, high temperatures or any other severely adverse conditions.

...

ELECTRICAL INSTALLATION

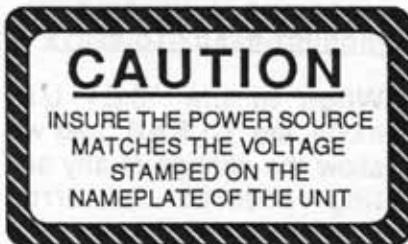

- The oven identification tag is permanently mounted on the back of the oven, near the power cord.

IDENTIFICATION TAG EXAMPLE

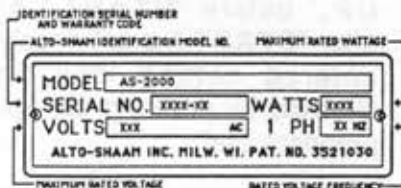

IMPORTANT: ANY AND ALL CLAIMS FOR WARRANTY MUST INCLUDE THE FULL MODEL NUMBER AND SERIAL NUMBER.

- The 125 volt rated unit will function properly with a source voltage of between 100 volts and 125 volts, 60 Hz.
- The 208-240 volt oven is a dual rated unit with a conversion switch mounted under an access cover on the rear of the oven, near the power cord. With the voltage conversion switch in the 200 volt through 208 volt (**UPPER**) position, the oven will function properly with a source voltage of between 200 volts and 208 volts, 50 or 60 Hz.
- With the voltage conversion switch in the 220-240 volt (**LOWER**) position, the unit will function properly with a source voltage of between 220 volts and 240 volts, 50 or 60 Hz.

VOLTAGE CONVERSION LABEL

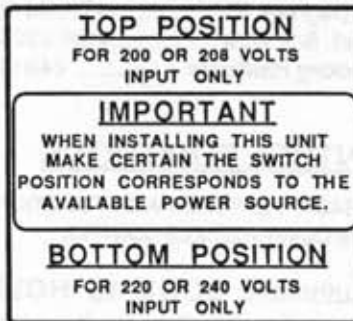

ELECTRICAL RATINGS

125 Volts 2100 Watts (maximum) 16.8 Amps (maximum)
 208 Volts 3000 Watts (maximum) 14.4 Amps (maximum)
 220 Volts 2200 Watts (maximum) 10.0 Amps (maximum)
 240 Volts 2600 Watts (maximum) 10.8 Amps (maximum)

NOTE: ALL 208-240 volts units are shipped from the factory with the voltage conversion switch in the 220-240 volt position. Again, insure that the voltage conversion switch position and the available power source match.

- The 125 volt rated units are provided with a cord and plug [NEMA #5-20P]. The 208-240 volt rated units are provided with a cord and plug [NEMA #6-20P].

PLUG & OUTLET CONFIGURATIONS

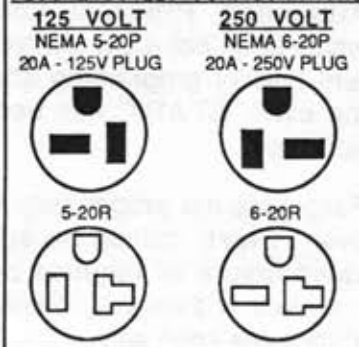

Have a qualified technician install the proper outlet configuration and assure that the oven is properly grounded, in accordance with the National Electrical Code and applicable local codes. This will insure safe and trouble-free installation.

- The oven is equipped with a combination circuit breaker/main power switch, located on the back of the unit near the power cord. Before operating the oven, make certain this switch is in the "ON" position by pressing the top of the switch "IN," toward the oven.

...

START-UP

- Before operating the oven, clean both the interior and exterior of the unit with a damp cloth and mild soap solution. Rinse well.
- Clean and install the oven side racks, oven shelves, and drip pan on the interior bottom surface.

NOTE: At no time should the inside or the outside of the oven be washed down, flooded with water or liquid solution. Never steam clean. The electronic control of the oven is designed to be water resistant, however, remember this is an electric appliance.



- Before operating the unit with product, become familiar with the operation of the control. Read the following "Operation" section of this manual and operate the various function modes of the computer control. For reference during actual operation, the basic operational procedures are printed on the control panel.

...

GENERAL CHARACTERISTICS

The unit is equipped with a special, patented thermal cable. Through the HALO HEAT concept, the heating cable is mounted against the walls of the cooking cavity to provide an evenly applied, computer controlled, heat input. The design and operational characteristics of the unit eliminates the need for moisture pans and/or heat circulating fans. Because of the even heat application, the quality of food products are maintained for long periods of time. The actual time depends on the type and quantity of product.

The computer control maintains an exceptionally close temperature tolerance and automatic control of the cooking cycle by either internal product temperature or timed cooking. Holding temperatures are maintained with reduced oven power consumption in the automatic "HOLD MODE."

...

OUTSIDE DIMENSIONS

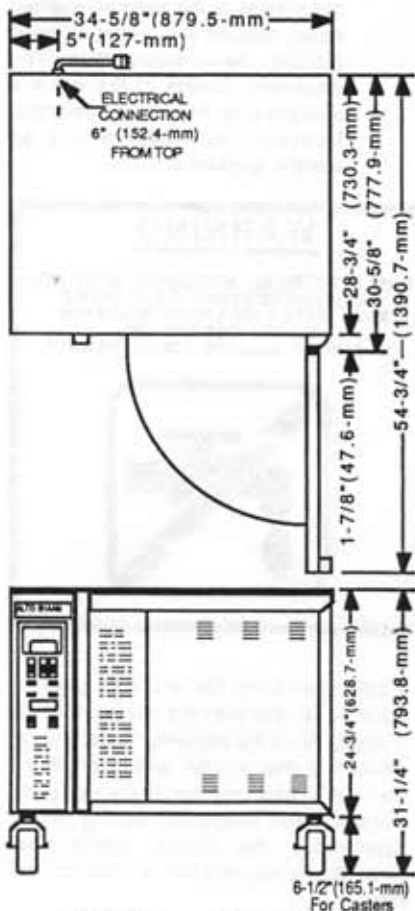

AS-2000 • CH-200

PAN CAPACITIES

FULL-SIZE PANS

Ten (10) 12" x 20" x 2-1/2"
GN 1/1 (530mm x 325mm x 65mm)

Four (4) 12" x 20" x 4"
GN 1/1 (530mm x 325mm x 100mm)

ON WIRE SHELVES ONLY — UP TO:

Five (5) 18" x 26" x 1" Sheet Pans

...

OPTIONS & ACCESSORIES

Bumper Guard.....#5221

CARVING HOLDERS:

•Prime Rib Holder.....#HL-2635

•Ship Round Holder..... #4459

Legs, 6" (152.4mm)#5205

POCKET THERMOMETER

•Degrees °F#TH-3300

•Degrees °C.....#TH-3412

Shelf, S/S Wire#SH-2324

Stacking Hardware #4011

...

CONTROL FUNCTIONS

THE BASIC FEATURES AND FUNCTIONS OF THE COMPUTERIZED CONTROL:

1. Automatic **COOK to HOLD** operation by time or by product temperature.
2. Manual holding.
3. Power, fail-safe feature which "**remembers**" the operational mode in the event of a power outage. When power is restored, this feature will return the oven to the operational mode the oven was in when the power was interrupted.
4. Automatic Program Lock which does not allow inadvertent loss of programming after the oven "START" has been activated.
5. Forget-me-not programming — oven "Start" cannot be activated unless all required parameters of time and temperature have been set.

6. The control will not allow unacceptable settings. The unacceptable number will flash three times in the digital display area and will automatically be disregarded by the computer. An acceptable number will have to be reentered. All acceptable number parameters are located next to the appropriate pad.

7. The oven will audibly "beep" each time a setting is pressed.

8. Digital display will indicate each set of numbers entered. Digital display will "recall" numbers already set, such as programmed temperature settings. Digital display will indicate internal product temperature when cooking by probe mode or remaining time when cooking by time mode.

9. Product Status Indicator, located at the top of the control, indicates the current status of the product...

COOKING • HOLDING PRODUCT-READY-TO-SERVE

10. When in the "SET-UP" mode, the "CLEAR" pad will allow the change of any setting entered in error. Previously set time or temperature, however, cannot be cleared. Full reset would be required.
11. At any time during "SET-UP," before "START," or after "START," a previously entered setting may be checked by pressing the appropriate pad.
12. The control has a built-in switch to convert the digital display readout from degrees F. to degrees C.

...

CONTROL PANEL — AS-2000 • CH-200

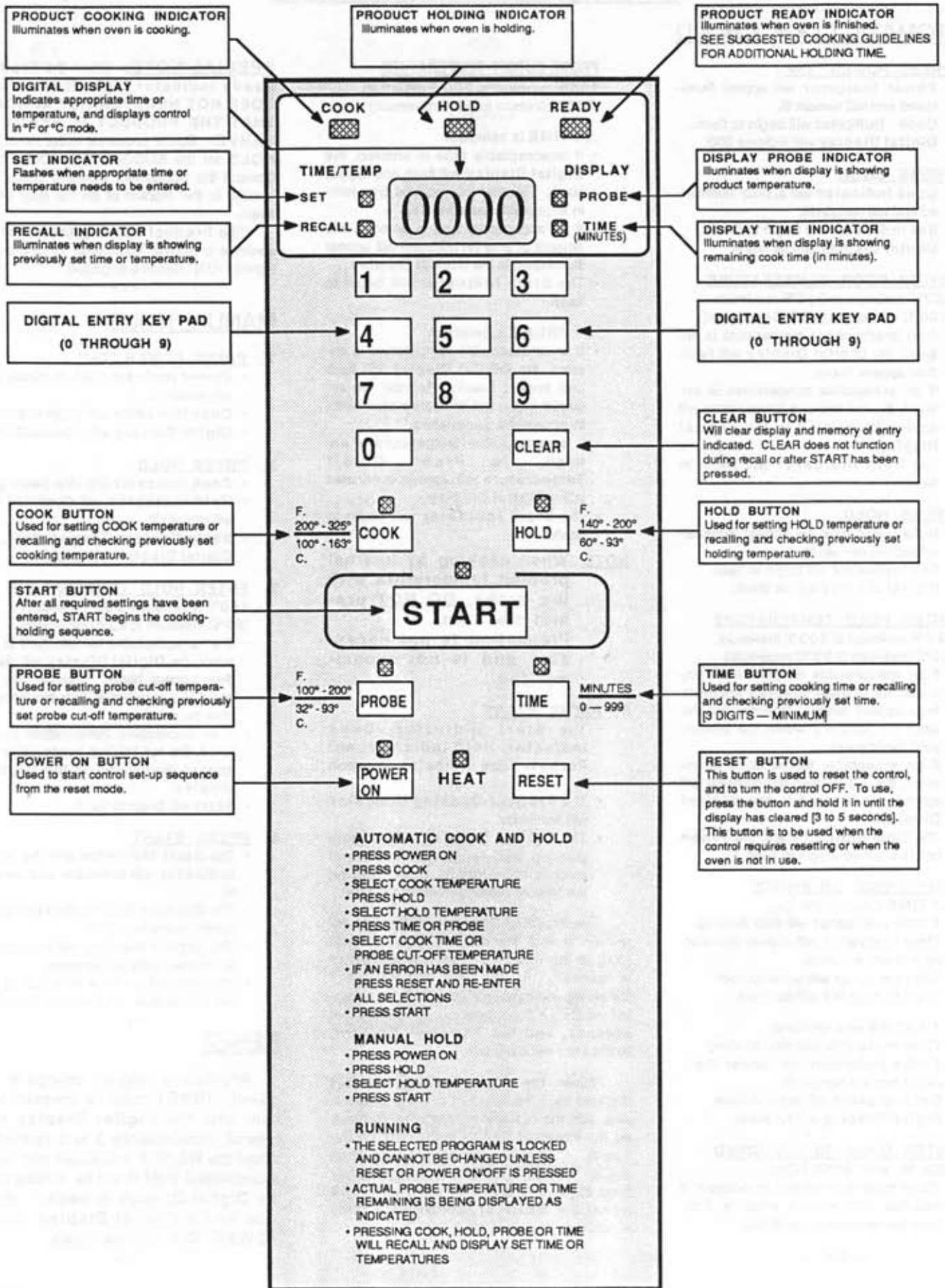

OPERATING PROCEDURE

AUTOMATIC COOK & HOLD

1. PRESS POWER "ON":

- Power Indicator will appear illuminated and will remain lit.
- Cook Indicator will begin to flash.
- Digital Display will indicate 000.

2. PRESS COOK

- Cook Indicator will appear illuminated and will remain lit.
- Set Indicator will begin to flash.
- Digital Display will be blank.

3. ENTER COOK TEMPERATURE

200°F minimum to 325°F maximum
(100°C minimum to 163°C maximum)

- If an unacceptable temperature is entered, the Digital Display will flash, then appear blank.
- If an acceptable temperature is entered, the set cooking temperature will appear illuminated in the Digital Display.
- The Hold Indicator will begin to flash.

4. PRESS HOLD

- Hold Indicator will appear illuminated and will remain lit.
- Set Indicator will begin to flash.
- Digital Display will be blank.

5. ENTER HOLD TEMPERATURE

140°F minimum to 200°F maximum
(60°C minimum to 93°C maximum)

- If an unacceptable temperature is entered, the Digital Display will flash, then appear blank. Reenter the desired temperature within the acceptable parameters.
- If an acceptable temperature is entered, the set holding temperature will appear illuminated in the Digital Display.
- The Time Indicator and the Probe Indicator will begin to flash.

6. PRESS TIME OR PROBE

...If TIME was selected:

- Probe Indicator will stop flashing.
- Time Indicator will appear illuminated and will remain lit.
- Set Indicator will begin to flash.
- Digital Display will be blank.

...If PROBE was selected:

- Time Indicator will stop flashing.
- Probe Indicator will appear illuminated and will remain lit.
- Set Indicator will begin to flash.
- Digital Display will be blank.

7. ENTER COOK TIME DESIRED (000 to 999 MINUTES)

- Three digits must always be entered. If less than 100 minutes, enter "0" first, then the remaining two digits.

PROBE CUTOFF TEMPERATURE

100°F minimum to 200°F maximum
(32°C minimum to 93°C maximum)

...If TIME is selected:

- If unacceptable time is entered, the Digital Display will flash and appear blank. Reenter the required time within acceptable parameters.
- If an acceptable time is entered, the amount of time (in minutes) will appear illuminated in the Digital Display.
- The Start Indicator will begin to flash.

...If PROBE is selected:

- If an unacceptable temperature is entered, the Digital Display will flash and appear blank. Reenter the required probe cut-off temperature within acceptable parameters.
- If an acceptable temperature is entered, the Probe Cutoff Temperature will appear illuminated in the Digital Display.
- The Start Indicator will begin to flash.

NOTE: When cooking by internal product temperature with the probe, **DO NOT** preheat the oven. Preheating is not necessary and is not recommended.

8. PRESS START

- The Start Indicator; Cook Indicator; Hold Indicator; and Probe or Time Indicator will remain lit.
- The Product Cooking Indicator will illuminate.
- The Digital Display will indicate cooking time remaining or internal product temperature, depending on the type of cooking method selected.

The Product Cooking Indicator will remain lit until the cooking time runs out (000) or the Probe Cutoff Temperature is reached. At this time, the Product Cooking Indicator will go "OUT," the control will BEEP for approximately three to five seconds, and the Product Holding Indicator will illuminate.

When the oven temperature has dropped from the selected cooking temperature, and the residual cooking has completed, the Product Ready Indicator will illuminate. The oven control will produce an audible ON/OFF BEEP for approximately three to five seconds. The oven control will repeat this BEEP in approximately three minutes.

SPECIAL NOTE: When the Product Ready Indicator Light illuminates, IT DOES NOT NECESSARILY INDICATE THAT THE PRODUCT IS READY TO SERVE. Some products must remain in HOLD for the SUGGESTED HOLD TIME. Consult the Suggested Cooking Guidelines located in this manual or on the door of the oven.

The Product Holding Indicator will continue to appear illuminated as long as the Power "ON" remains engaged.

...

MANUAL HOLD

1. PRESS POWER "ON"

- Power Indicator will illuminate and will remain lit.
- Cook Indicator will begin to flash.
- Digital Display will indicate (000).

2. PRESS HOLD

- Cook Indicator will stop flashing.
- Hold Indicator will illuminate and will remain lit.
- Set Indicator will begin to flash.
- Digital Display will be blank.

3. ENTER HOLD TEMPERATURE

140°F minimum to 200°F maximum
(60°C minimum to 93°C maximum)

- If an unacceptable temperature is entered, the Digital Display will flash, then appear blank. Reenter the desired temperature within the acceptable parameters.
- If an acceptable temperature is entered, the set holding temperature will appear illuminated in the Digital Display.
- Start will begin to flash.

4. PRESS START

- The Start Indicator and the Hold Indicator will illuminate and remain lit.
- The Product Hold Indicator will illuminate and remain lit.
- The Digital Display will indicate interior oven (air) temperature.
- The oven will continue to HOLD at the set temperature until reset is pressed.

...

RESET

Any time a program change is required, RESET must be pressed and held until the Digital Display has cleared (approximately 3 to 5 seconds). When the RESET is pressed and held, a continuous BEEP will be audible until the Digital Display is cleared. After clearing the Digital Display, press POWER "ON" and reprogram.

...

SUGGESTED COOKING GUIDELINES

THIS CHART GIVES SUGGESTED SETTINGS FOR VARIOUS PRODUCTS. FOR ADDITIONAL PRODUCT OR COOKING INFORMATION, PLEASE REFER TO THE ALTO-SHAAM GUIDE TO LOW TEMPERATURE COOKING AND HOLDING.

WHEN THE OVEN HAS COMPLETED THE COOKING CYCLE, THE "PRODUCT HOLDING" LIGHT WILL ILLUMINATE. THE PRODUCT IS NOT READY TO BE REMOVED FROM THE OVEN. THERE IS A SIGNIFICANT AMOUNT OF RESIDUAL COOKING COMPLETED IN THE HOLDING CYCLE. THE INTERNAL PRODUCT TEMPERATURE WILL RISE TO A FINISHED LEVEL OF 10°F (5.5°C) TO 30°F (17°C) ABOVE THE PROBE TEMPERATURE SETTING. BASED ON THE FINISHED INTERNAL PRODUCT TEMPERATURE, THE PROBE OR TIME SETTINGS MAY NEED SLIGHT ADJUSTMENT.

AFTER APPROXIMATELY 1 TO 2 HOURS, THE "PRODUCT READY" LIGHT WILL ILLUMINATE. AT THIS TIME, THE PRODUCT HAS COMPLETED COOKING, HOWEVER, THE PRODUCT SHOULD REMAIN IN THE OVEN FOR AT LEAST THE SUGGESTED HOLD TIME GIVEN IN THE CHART. THIS ASSURES A MORE CONSISTENT, TENDER PRODUCT.

PRODUCT	COOK TEMPERATURE	HOLD TEMPERATURE	PROBE TEMPERATURE	MANUAL COOK TIME	SUGGESTED HOLD TIME
BEEF CORN BEEF FRESH BRISKET	250°F — (121°C)	160°F — (71°C)	WELL 128°F - 140°F (53°C - 60°C)	80 - 100 POUNDS (36 - 45 kg) (FILM-WRAP COVER) 20 MINUTES PER POUND FOR THE FIRST PIECE • ADD 30 MINUTES FOR EACH ADDITIONAL PIECE	6 HOURS OR MORE
PRIME RIB — BONE-IN	250°F — (121°C)	140°F — (60°C)	RARE 105°F - 115°F (41°C - 46°C) MED. 118°F - 128°F (48°C - 53°C) WELL 128°F - 140°F (53°C - 60°C)	120 POUNDS (54 kg) 10 MINUTES PER POUND FOR THE FIRST ROAST • ADD 15 MINUTES FOR EACH ADDITIONAL ROAST — NOTE: REMOVE FAT CAP	4 HOURS
PRIME RIB — NO BONE	250°F — (121°C)	140°F — (60°C)	RARE 105°F - 115°F (41°C - 46°C) MED. 118°F - 128°F (48°C - 53°C) WELL 128°F - 140°F (53°C - 60°C)	100 POUNDS (45 kg) FOR: 12 lb (5 kg) ROASTS 10 MINUTES PER POUND FOR THE FIRST ROAST • ADD 10 MINUTES FOR EACH ADDITIONAL ROAST FOR: 8 - 10 lb (4 - 5 kg) ROASTS 8 MINUTES PER POUND FOR THE FIRST ROAST • ADD 8 MINUTES FOR EACH ADDITIONAL ROAST	4 HOURS
TOP & BOTTOM ROUNDS	250°F — (121°C)	140°F — (60°C)	RARE 105°F - 115°F (41°C - 46°C) MED. 118°F - 128°F (48°C - 53°C) WELL 128°F - 140°F (53°C - 60°C)	80-120 POUNDS (36-54 KG) FOR: 10 - 14 lb (5-6 kg) ROASTS 10 MINUTES PER POUND FOR THE FIRST ROAST • ADD 15 MINUTES FOR EACH ADDITIONAL ROAST FOR: 15-20 lb (7-9 KG) ROASTS 10 MINUTES PER POUND FOR THE FIRST ROAST • ADD 30 MINUTES FOR EACH ADDITIONAL ROAST	6 HOURS
SHIP ROUND CAFETERIA ROUND	250°F — (121°C)	140°F — (60°C)	RARE 105°F - 115°F (41°C - 46°C) MED. 118°F - 128°F (48°C - 53°C) WELL 128°F - 140°F (53°C - 60°C)	80 POUNDS (36 kg) FOR: 30-40 lb (14-18 kg) ROASTS 10 MINUTES PER POUND FOR THE FIRST ROAST • ADD 30 MINUTES FOR EACH ADDITIONAL ROAST FOR: 50-80 lb (23-36 kg) ROASTS 7 MINUTES PER POUND	8 HOURS
VEAL ROAST	250°F — (121°C)	160°F — (71°C)	WELL 128°F - 140°F (53°C - 60°C)	100 POUNDS (45 kg) FOR: 8-10 lb (4-5 kg) ROASTS 12 MINUTES PER POUND FOR THE FIRST ROAST • ADD 20 MINUTES FOR EACH ADDITIONAL ROAST	1 HOUR
LAMB LAMB (LEG or RACK)	250°F — (121°C)	140°F — (60°C) 160°F — (71°C)	RARE 105°F - 115°F (41°C - 46°C) MED. 118°F - 128°F (48°C - 53°C) WELL 128°F - 140°F (53°C - 60°C)	80-120 POUNDS (36-54 kg) FOR: 8-10 lb (4-5 kg) ROASTS WELL-DONE: 15 MINUTES PER POUND FOR THE FIRST ROAST • ADD 15 MINUTES FOR EACH ADDITIONAL ROAST MED. RARE: 12 MINUTES PER POUND FOR THE FIRST ROAST • ADD 12 MINUTES FOR EACH ADDITIONAL ROAST	2 HOURS
PORK HAM — FRESH	250°F — (121°C)	160°F — (71°C)	165°F — (74°C)	100 POUNDS (45 kg) FOR: 15-18 lb (7-8 kg) HAMS 12 MINUTES PER POUND FOR THE FIRST HAM • ADD 30 MINUTES FOR EACH ADDITIONAL HAM	2 HOURS
HAM — SMOKED — BONELESS	250°F — (121°C)	160°F — (71°C)	165°F — (74°C)	100 POUNDS (45 kg) FOR: 15-18 lb (7-8 kg) HAMS 12 MINUTES PER POUND FOR THE FIRST HAM • ADD 30 MINUTES FOR EACH ADDITIONAL HAM	NONE
PORK CHOPS	250°F — (121°C)	160°F — (71°C)	165°F — (74°C)	FOUR (4) 18" x 26" SHEET PANS (FILM-WRAP COVER) 1-1/2 TO 2-1/2 HOURS	1-1/2 HOURS
PORK RIBS — BACK or SPARE	250°F — (121°C)	160°F — (71°C)	165°F — (74°C)	60 POUNDS (27 kg) (FILM-WRAP COVER) 3-1/2 TO 4-1/2 HOURS	1-1/2 HOURS
PORK ROAST	275°F — (135°C)	160°F — (71°C)	165°F — (74°C)	100 POUNDS (45 kg) FOR: 8-12 lb (4-5 kg) ROASTS 15 MINUTES PER POUND FOR THE FIRST ROAST • ADD 30 MINUTES FOR EACH ADDITIONAL ROAST	2 HOURS
POULTRY CHICKEN BREASTS — BONELESS	275°F — (135°C)	160°F — (71°C)	165°F — (74°C)	TWO (2) 18" x 26" SHEET PANS (FILM-WRAP COVER) 1-1/2 TO 2-1/2 HOURS	NONE
CHICKEN — HALVES or PIECES	275°F — (135°C)	160°F — (71°C)	165°F — (74°C)	48 HALVES 2-1/2 TO 3 HOURS	1/2 HOUR
CHICKEN — WHOLE	275°F — (135°C)	160°F — (71°C)	165°F — (74°C)	18 WHOLE CHICKENS FOR: 3 lb (1.4 kg) CHICKENS 3 TO 3-1/2 HOURS	1 HOUR
TURKEY — WHOLE	275°F — (135°C)	160°F — (71°C)	165°F — (74°C)	TWO (2) 25 POUND (11 kg) TURKEYS 3 TO 5 HOURS	1 HOUR
DUCK	300°F — (149°C)	160°F — (71°C)	175°F — (79°C)	18 WHOLE DUCKS FOR: 4-5 lb (2 kg) DUCKS 2-1/2 TO 3 HOURS	1 HOUR
FISH FISH — BAKED	275°F — (135°C)	160°F — (71°C)	145°F — (63°C)	FOUR (4) 18" X 26" SHEET PANS (FILM-WRAP COVER) 1-1/2 TO 2-1/2 HOURS	NONE
MISCELLANEOUS POTATOES	300°F — (149°C)	180°F — (82°C)	188°F — (87°C)	60 POTATOES (80-90 COUNT) 3 TO 4 HOURS	NONE

CARE and MAINTENANCE

EQUIPMENT CARE

Under normal circumstances, this oven should provide you with long and trouble-free service. There is no preventative maintenance required, however, the following *Equipment Care Guide* will maximize the potential life and trouble-free operation of this oven.



1. CLEAN DAILY

Remove all detachable items such as wire shelves, side racks, and drip pan. Clean these items separately. With the oven disconnected from the power source, any spilled food or grease on the oven interior should be removed with a damp cloth and any good grease solvent, commercial detergent or soap. **AT NO TIME SHOULD THE OVEN INTERIOR OR EXTERIOR BE STEAM CLEANED, WASHED DOWN, FLOODED WITH WATER OR LIQUID SOLUTION.** Do not use abrasive cleaners on the exterior of the oven. Keep the meat probe clean and sanitized at **ALL** times.



2. DO NOT USE THE OVEN IF THE CONTROLS ARE NOT PROPERLY FUNCTIONING.

Refer to the *Trouble Shooting Guide* located in this manual or call an authorized service technician.

3. CHECK OVERALL CONDITION OF THE OVEN ONCE A MONTH.

Check the oven once a month for physical damage and loose screws, particularly the door mounting screws. Correct any problems before they begin to interfere with the operation of the oven.

4. CHECK THE COOLING FAN IN THE OVEN CONTROL AREA.

While the oven is warm, check that the cooling fan in the oven control area is functioning. The fan is located on the back of the unit, toward the top.

CONFIDENCE TEST

You have tried your new Electronic Cooking and Holding Oven, and you don't believe it's working properly. **BEFORE YOU CALL FOR SERVICE**, try these simple tests. It will assure you that the controls are correct, and instead of needing service, you may need some assistance with proper cooking procedure.

PROBE OPERATION TEST

1. Empty the oven compartment of product.
2. Place one (1) wire shelf in the center of the oven compartment.
3. Make absolutely certain the meat probe is clean.
4. Place the meat probe on the wire shelf located in the center of the oven compartment. The tip of the meat probe should be located in the center of the oven cavity, but must not touch the wire shelf.
5. Press power "ON" and set the oven controls:
 - A. COOK TEMPERATURE 250°F (121°C)
 - B. HOLD TEMPERATURE 140°F (60°C)
 - C. PROBE TEMPERATURE 115°F (46°C)

PRESS START, and watch the Digital Display on the oven control panel. In approximately 10 to 15 minutes, the air temperature inside the oven will climb toward the set COOK temperature of 250°F (121°C), and the meat probe will reach the set PROBE temperature. When the meat probe reaches the set PROBE temperature of 115°F (46°C):

- A. PRODUCT COOKING INDICATOR light will go "OUT."
- B. The HEAT INDICATOR light will go "OUT."
- C. The PRODUCT READY and PRODUCT HOLDING INDICATOR light will illuminate.
- D. The oven control will produce a three second, audible BEEP.
- E. The DIGITAL DISPLAY will indicate the approximate PROBE TEMPERATURE of 115°F (46°C).

This concludes the Probe Temperature Test. If the control operates as indicated above, the probe circuit is functioning properly. **BEFORE BEGINNING THE HOLDING TEMPERATURE TEST**, turn the oven "OFF" by pressing the RESET button.

HOLDING OPERATION TEST

1. With the oven cavity empty of product, press power "ON."
2. Press the HOLD button.
3. Set HOLD temperature at 200°F (93°C).
4. Activate the HOLD cycle by pressing the START button.
5. The DIGITAL DISPLAY will indicate the air temperature inside the oven.

When the DIGITAL DISPLAY indicates a temperature under 200°F (93°C):

- A. The HEAT INDICATOR light will flicker as the oven calls for additional heat.
- B. The HEAT INDICATOR light will continue to flicker until the oven reaches the set HOLD temperature of 200°F (93°C).

When the DIGITAL DISPLAY indicates a temperature of 200°F (93°C), and increases to 202°F (94°C):

- A. The HEAT INDICATOR light will go "OUT."
- B. The HEAT INDICATOR light will remain "OUT" until the air temperature inside the oven falls below 200°F (93°C).

This concludes the Holding Temperature Test. If the control operates as indicated above, the holding circuit is functioning properly. **BEFORE BEGINNING THE COOKING TEMPERATURE TEST**, turn the oven "OFF" by pressing the RESET button.

COOKING OPERATION TEST

1. With the oven cavity empty of product press power "ON."
2. Set the oven controls:
 - A. COOK TEMPERATURE, 250°F (121°C)
 - B. HOLD TEMPERATURE, 140°F (60°C)
 - C. TIME — 075 MINUTES
 - D. Press START.

In approximately 1 to 1-1/2 hours, the air temperature inside the oven will reach the set COOK temperature of 250°F (121°C). WHEN THE TIME EXPIRES:

- A. PRODUCT COOKING INDICATOR light will go "OUT."
- B. PRODUCT HOLDING INDICATOR light will illuminate.
- C. The oven control will produce a three second, audible BEEP.
- D. The DIGITAL DISPLAY will indicate 000.

...As soon as the time expires:

- A. Press the RESET button and reactivate the oven by pressing the POWER "ON" button.
- B. Press the HOLD button.
- C. Set the HOLD temperature at 200°F (93°C).
- D. Press the START button.

The DIGITAL DISPLAY will indicate the air temperature inside the oven. This air temperature will approximate the set COOK TEMPERATURE of 250°F (121°C).

This concludes the Cooking Temperature Test. If the control operates as indicated above, the cooking circuit is functioning properly.

...

SANITATION GUIDELINES

Food flavor and aroma are usually so closely related that it is difficult, if not impossible, to separate them. There is also an important, inseparable relationship between cleanliness and food flavor. Cleanliness, top operating efficiency, and appearance of equipment contribute considerably to savory, appetizing foods. Good equipment that is kept clean, works better and lasts longer.

Most food imparts its own particular aroma and many foods also absorb existing odors. Unfortunately, during this absorption, there is no distinction between *GOOD* and *BAD* odors. The majority of objectionable flavors and odors troubling food service operations are caused by bacteria growth. Sourness, rancidity, mustiness, stale or other *OFF* flavors are usually the result of germ activity.

The easiest way to insure full, natural food flavor is through comprehensive cleanliness. This means good control of both visible soil (dirt) and invisible soil (germs). Clean surfaces don't smell — this is a basic and important fact to insure good quality in food of all kinds.

A thorough approach to sanitation will provide essential cleanliness. It will assure an attractive appearance of equipment, along with maximum efficiency and utility. More importantly, a good sanitation program provides one of the key elements in the prevention of food-borne illnesses.

A controlled holding environment for prepared foods is just one of the important factors involved in the prevention of food-borne illnesses. Temperature monitoring and control during receiving, storage, preparation, and the service of food are of equal importance.

The most accurate method of measuring safe temperatures of both hot and cold foods is by internal product temperature. A quality thermometer is an effective tool for this purpose and should be routinely used on all products that require holding at a specific temperature.

HOT FOODS			
40° to 140°F	DANGER ZONE	4.44° to 60°C	
70° to 120°F	CRITICAL ZONE	21.11° to 49°C	
140° to 165°F	SAFE ZONE	60° to 74°C	

COLD FOODS			
Above 40°F	DANGER ZONE	Above 4.44°C	
40°F or Below	SAFE ZONE	4.44°C or Below	

FROZEN FOODS			
Above 32°F	DANGER ZONE	Above 0°C	
0° to 32°F	CAUTION ZONE	-17.8° to 0°C	
0°F or Below	SAFE ZONE	-17.8°C or Below	

A comprehensive sanitation program should focus on the training of staff in basic sanitation procedures. This includes personal hygiene, proper handling of raw foods, cooking to a safe internal product temperature, and the routine monitoring of internal temperatures from receiving through service.

Most food-borne illnesses can be prevented through proper temperature control and a comprehensive program of sanitation. All these factors are important to build quality service as the foundation of customer satisfaction.

...

HOLDING GUIDELINES

Chefs, cooks and other specialized food service personnel employ varied methods of cooking. Proper holding temperatures for a specific food product must be based on the moisture content of the product, product density, volume, and proper serving temperatures. Safe holding temperatures must also be correlated with palatability in determining the length of holding time for a specific product. The fact that HALO HEAT is able to maintain a consistent temperature within the cabinet, without the necessity of a heat distribution fan, points out the major advantage of holding in this system. Since there is a motionless heated air mass within the heated compartment, the product does not lose any major moisture content due to evaporation or dehydration.

In a holding environment, too much moisture content is a condition which can be relieved. A product achieving extremely high temperatures in preparation must be allowed to decrease in temperature before being placed in a controlled holding atmosphere. If the product is not allowed to decrease in temperature, excessive condensation will form increasing the moisture content on the outside of the product.

Most HALO HEAT Holding Equipment is provided with a thermostat control between 60°F and 200°F (16°C to 93°C). If the unit is equipped with vents, close the vents for moist holding and open the vents for crisp holding.

If the unit is equipped with a thermostat indicating a range of between 1 and 10, use a metal-stemmed indicating thermometer to measure the internal temperature of the product(s) being held. Adjust the thermostat setting to achieve the best overall setting based on internal product temperature.

...

HOLDING TEMPERATURE RANGE					
THE TEMPERATURES LISTED BELOW ARE SUGGESTED GUIDELINES ONLY					
MEAT			LAMB	160°F • 175°F	71°C • 79°C
BEEF ROAST (rare)	140°F • _____	60°C • _____	POULTRY		
BEEF ROAST (med., well)	160°F • _____	71°C • _____	CHICKEN (fried or baked)	160°F • 175°F	71°C • 79°C
BEEF BRISKET	160°F • 175°F	71°C • 79°C	DUCK	160°F • 175°F	71°C • 79°C
CORN BEEF	160°F • 175°F	71°C • 79°C	POULTRY (general)	160°F • 175°F	71°C • 79°C
PASTRAMI	160°F • 175°F	71°C • 79°C	TURKEY	160°F • 175°F	71°C • 79°C
PRIME RIB (rare)	140°F • _____	60°C • _____	FISH/SEAFOOD		
STEAKS (broiled or fried)	140°F • 160°F	60°C • 71°C	FISH (baked or fried)	160°F • 175°F	71°C • 79°C
RIBS — BEEF or PORK	160°F • _____	71°C • _____	LOBSTER	160°F • 175°F	71°C • 79°C
VEAL	160°F • 175°F	71°C • 79°C	SHRIMP (fried)	160°F • 175°F	71°C • 79°C
HAM	160°F • 175°F	71°C • 79°C	MISCELLANEOUS		
PORK	160°F • 175°F	71°C • 79°C	BREADS, ROLLS	120°F • 140°F	49°C • 60°C
			MISCELLANEOUS		
			CASSEROLES	160° F • 175°F	71°C • 79°C
			DOUGH (proofing)	80°F • 100°F	27°C • 38°C
			EGGS (fried)	150°F • 160°F	66°C • 71°C
			FROZEN ENTREES	160°F • 175°F	71°C • 79°C
			HORS D'OEUVERS	160°F • 180°F	71°C • 82°C
			PASTA	160°F • 180°F	71°C • 82°C
			PIZZA	160°F • 180°F	71°C • 82°C
			POTATOES	180°F • _____	82°C • _____
			PREPLATED MEALS	180°F • _____	82°C • _____
			SAUCES, SOUPS	140°F • 200°F	60°C • 93°C
			VEGETABLES	160°F • 175°F	71°C • 79°C

TROUBLE SHOOTING CHECK LIST

<u>PROBLEM</u>	<u>POSSIBLE CAUSE</u>	<u>REMEDY</u>
A. Unit does not operate	<ol style="list-style-type: none"> 1. No electrical power 2. Defective plug or cord 3. Circuit breaker tripped 4. Faulty wiring 5. Defective control 	Check power source Replace Reset — If it continues to trip, see Item (F.) below Repair Replace
B. Control operates, but unit does not function properly	<ol style="list-style-type: none"> 1. Operating procedures 2. Power source not matched to unit 3. Sensor or probe is dirty 4. Sensor or probe is defective 5. Control over-heating 	Check procedures Check position of voltage conversion switch with power source or relocate unit to proper power source. Clean Replace Clean or replace control cooling fan. Replace thermostat.
C. Probe temperature displays 286°F or 32°F (286°C max. to 0°C min.)	<ol style="list-style-type: none"> 1. Faulty wiring to probe 2. Defective probe 	Repair Replace
NOTE: The probe will not display temperatures in excess of those shown in (C.) above, even if the oven is hotter or colder.		
D. Control does not reset	<ol style="list-style-type: none"> 1. Operating procedures 2. Defective control 	Check procedures Replace control
E. Unit heats excessively above or below set temperature. Unit heats when oven is OFF.	<ol style="list-style-type: none"> 1. Heating element open or shorted 2. Oven sensor 	Replace Replace
F. Circuit breaker trips	<ol style="list-style-type: none"> 1. Power source not matched to unit 	Check position of voltage conversion switch with power source or relocate unit to proper power source.
G. Product overcooks	<ol style="list-style-type: none"> 1. Operating procedures 2. Power source not matched to unit 3. Defective probe 4. Shorted element 5. Defective control 	Check procedures Check position of voltage conversion switch with power source or relocate unit to proper power source. Replace Replace Replace
H. Product undercooks	<ol style="list-style-type: none"> 1. Operating procedures 2. Power source not matched to unit 3. Defective probe 4. Shorted element 5. Defective control 	Check procedures Check position of voltage conversion switch with power source or relocate unit to proper power source. Replace Replace Replace
I. Product overcooks & undercooks	<ol style="list-style-type: none"> 1. Operating procedures 	Check procedures
J. Control does not beep	<ol style="list-style-type: none"> 1. Faulty wiring 2. Defective beeper 	Repair Replace

REPAIR and SERVICE

OVEN TEMPERATURE and CALIBRATION

The oven thermostat is part of the electronic computer control, and is a precise instrument, therefore, no specific thermostat calibration is ever necessary. If you suspect the oven does not match the set temperature, check the ambient (air) temperature within the oven cavity with a quality thermal indicator.

1. With the exception of the two (2) oven side racks, the three (3) wire shelves and the drip pan, empty the oven cavity.
2. Place the thermal indicator in the center of the oven cavity.
3. Check to make certain the unit voltage matches the power source.
4. Make certain the oven sensor, located inside the oven cavity at the back of the unit, is clean.
5. Allow at least one (1) hour for the cavity temperature to stabilize before reading the cavity temperature on the thermal indicator.



...

CHECKING/REPLACING PROBE or SENSOR

The probe and oven sensor are mounted on the inside back of the oven cavity. There is an access cover to the probe and sensor wiring hook-up at the same approximate location on the outside back of the unit. To check the probe or sensor, take a resistance reading with a quality ohm meter, on the low ohms scale. The reading, with the oven at room temperature, should be between 100 and 120 ohms. If the resistance is higher or lower, the probe or sensor requires replacement. Insure good connections when replacing the probe or sensor. In addition to using the wire nuts, solder all connections.

...

CHECKING/REPLACING CONTROL COOLING FAN

If the Cooling Fan is not operating, initially check to make certain it is receiving power from the Cooling Fan Thermostat. The Cooling Fan Thermostat is located on the outside top of the oven cavity.

NOTE: The Cooling Fan does not operate until the oven cavity temperature reaches at least 140°F (60°C). If the fan is receiving power but is still not operating, replace the

Cooling Fan. When replacing the Cooling Fan, insure that the fan is positioned to blow air INTO the control cavity.

...

CONTROL COOLING FAN THERMOSTAT

The Cooling Fan Thermostat should close "ON" when the oven cavity reaches approximately 140°F (60°C) and open "OFF" when the oven cavity decreases to room temperature. Replace if needed.

...

BEEPER

The Beeper is located inside the control cavity, on the bottom. Check the wiring to the Beeper. If the wiring is good and all other aspects of the control function properly, replace the Beeper.

...

CIRCUIT BREAKER POWER SWITCH

If the Circuit Breaker/Power Switch trips:

1. Check the unit thoroughly for possible shorts.
2. Test the current draw with a quality amp meter.
3. Compare the readings with the electrical ratings located in this manual.
4. If the readings are substantially correct (NEVER OVER 15 Amps) replace the Circuit Breaker/Power Switch.

...

CHECKING/REPLACING HEATING ELEMENT

1. Check continuity, from each element to ground, with a quality ohm meter. There should be no continuity. If there is continuity, replace the element.
2. Check the resistance of each element:
HIGH TEMPERATURE ELEMENT —
.66 ohms/foot (2.17 ohms/meter)
...Approximately 20-24 ohms per length for 125 volt units
...Approximately 40-44 ohms per length for 208-240 volt units

If the resistance is very high or low, replace the element. When replacement of the element is required, complete instructions will be provided with shipment of the new element.

NOTE: In the event only one element requires replacement, check the remaining elements for any deterioration and replace at this time.

...

CONTROL REPLACEMENT PROCEDURES

Before attempting to replace the control, make certain the problem is in the control and not in the oven. Thoroughly check the oven for ground faults, shorts, etc.

The control can be replaced from the front of the unit. The chrome retaining ring, around the control panel, is removed by removing two (2) screws at the bottom of the ring. Lift the chrome retaining ring up and off the control panel. (The retaining ring is hooked at the top of the control panel.) Slide the control forward until the top of the control can be pivoted out and down. The body of the control is fastened by two studs. These studs will hold the control in place, while the wiring is being disconnected.

Label each control wire BEFORE disconnecting. This will insure each wire will be connected to the correct terminal point on the replacement control. When all wires are removed from the control, pull the control out of the unit by aligning the studs on the control with the slots in the control opening. Insert the replacement control and attach all wires according to the labels. Align the new control between the retaining projections and fully insert it in the unit. Hook the chrome retaining ring to the top of the control panel and secure at the bottom of the control panel with the two (2) screws.

Check the new control system by operating the oven according to the standard Operating Procedures located in this manual.

...

CHANGE FROM °F MODE TO °C MODE

Remove the top of the unit and locate the slide switch at the top of the control. This is the degrees Fahrenheit to degrees Celsius Conversion Switch. Slide the switch to the position desired.

When in the °F position, the oven controls must be set with °F temperatures (within °F parameters). The Digital Display will show only °F temperatures.

When in the °C position, the oven controls must be set with °C Temperatures (with °C parameters). The Digital Display will show only °C temperatures.

...



AS-2000, CH-200
SERVICE VIEW

3/8" x 1/2"

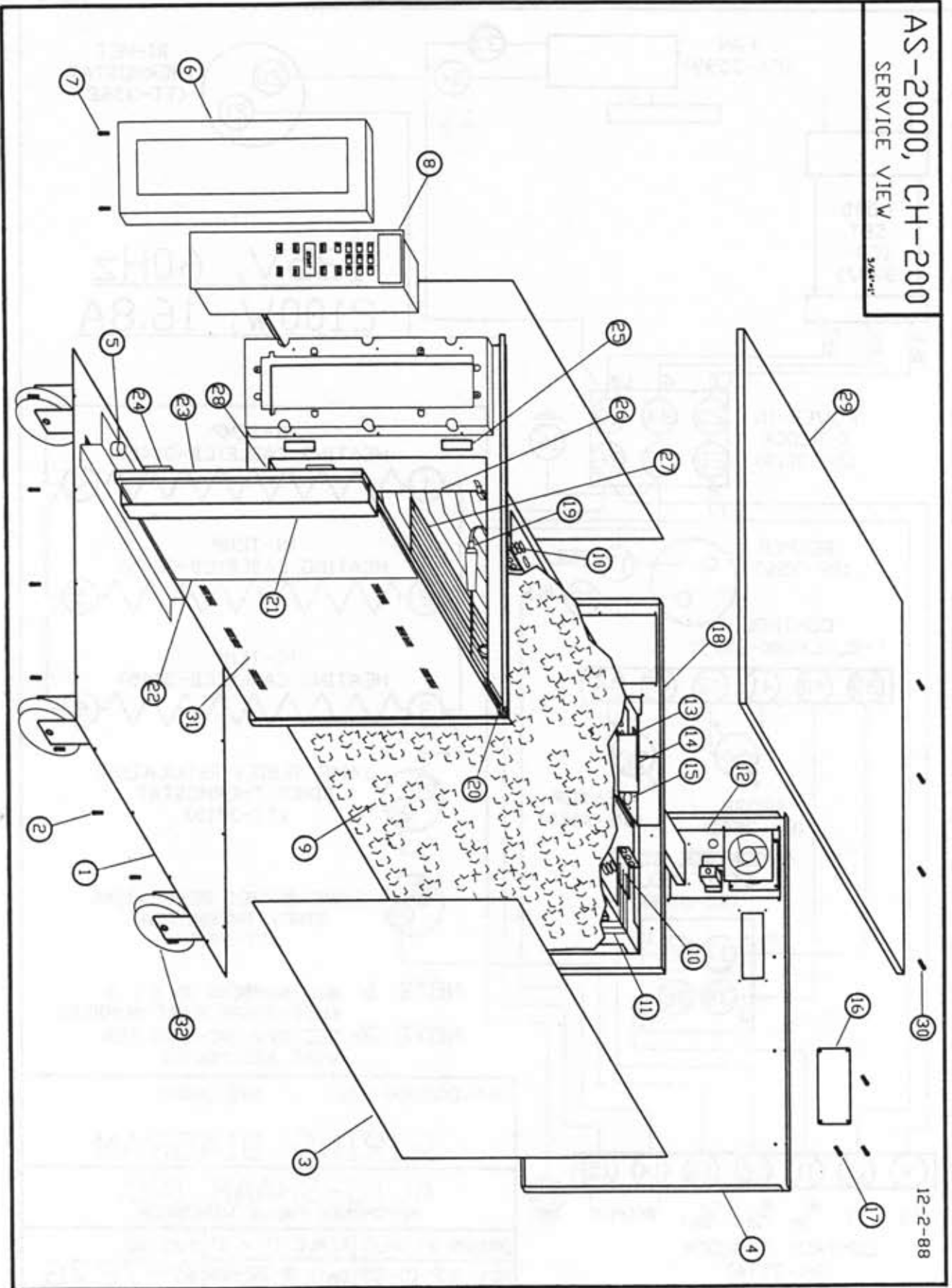

12-2-88

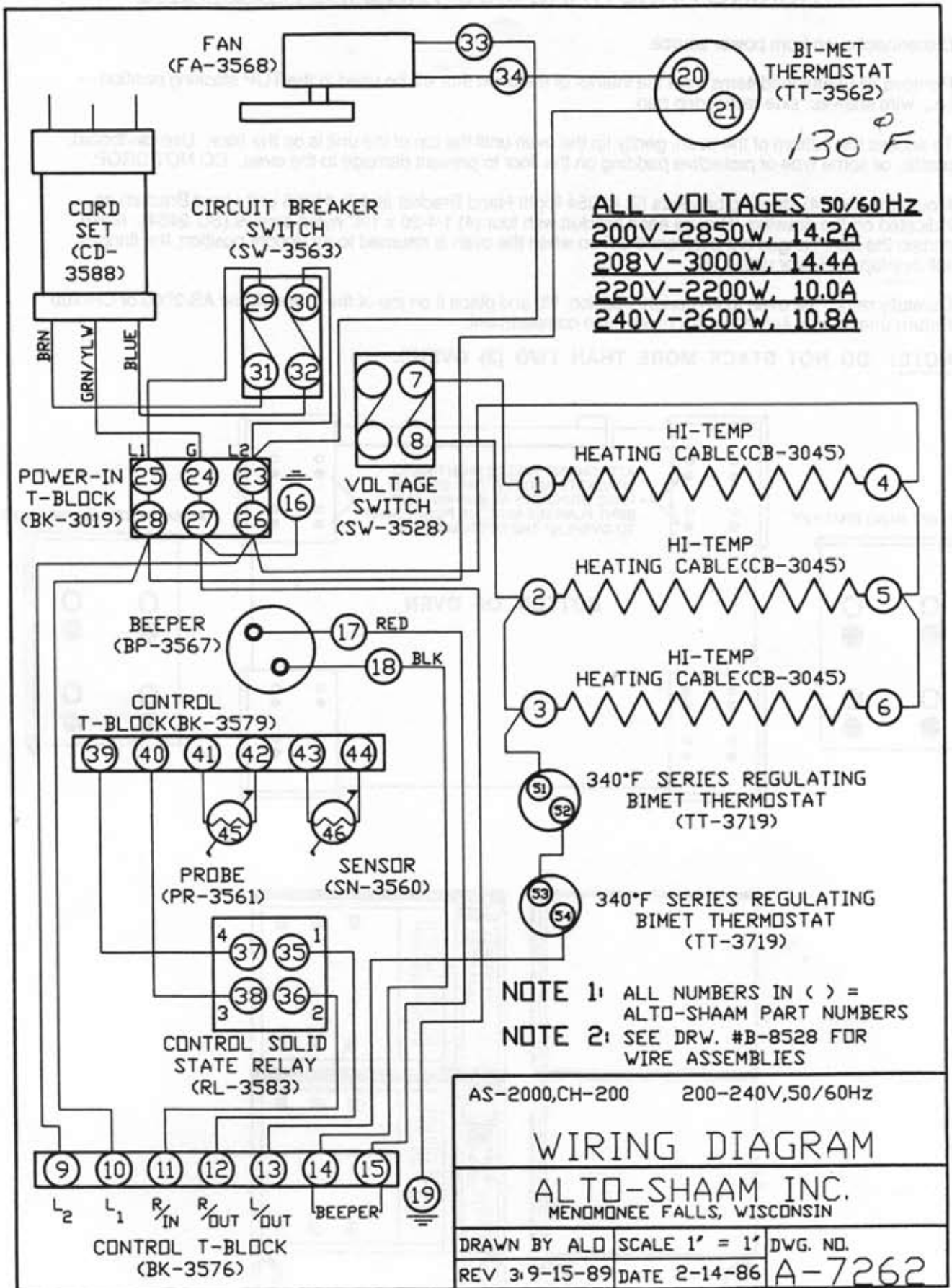

STACKING HARDWARE MOUNTING INSTRUCTIONS

1. Disconnect oven from power source.
2. Remove all unattached items from the interior of the oven that will be used in the TOP stacking position — i.e., wire shelves; side racks; drip pan.
3. To access the bottom of the oven, gently tip the oven until the top of the unit is on the floor. Use cardboard, plastic, or some type of protective padding on the floor to prevent damage to the oven. DO NOT DROP.
4. Mount the four (4) stacking brackets (2: #1054 Right-Hand Bracket and 2: #1055 Left-Hand Bracket) as indicated on the drawing. Secure each bracket with four (4) 1/4-20 x 1/4" nylon screws (SC-2464). Make certain the bent flanges are positioned UP so when the oven is returned to an upright position, the flanges will overlap the lower unit.
5. Carefully return the oven to an upright position, lift, and place it on top of the lower Model AS-2000 or CH-200. Return unattached items to the interior oven compartment.

NOTE: DO NOT STACK MORE THAN TWO (2) OVENS.

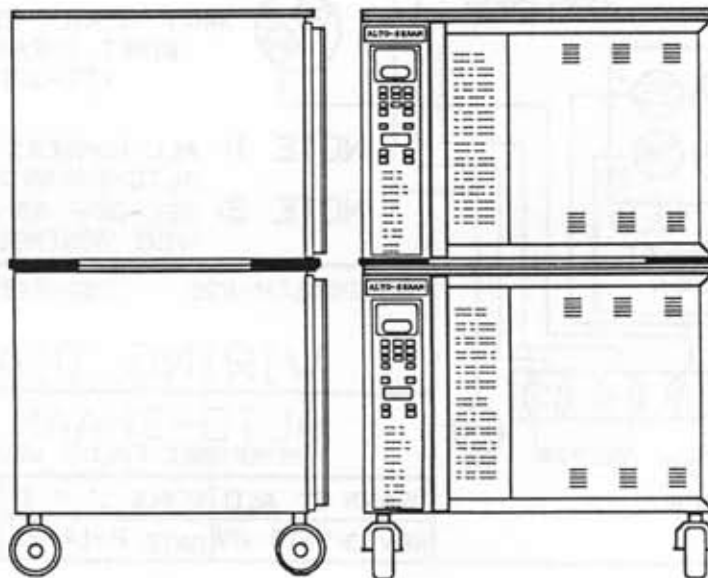
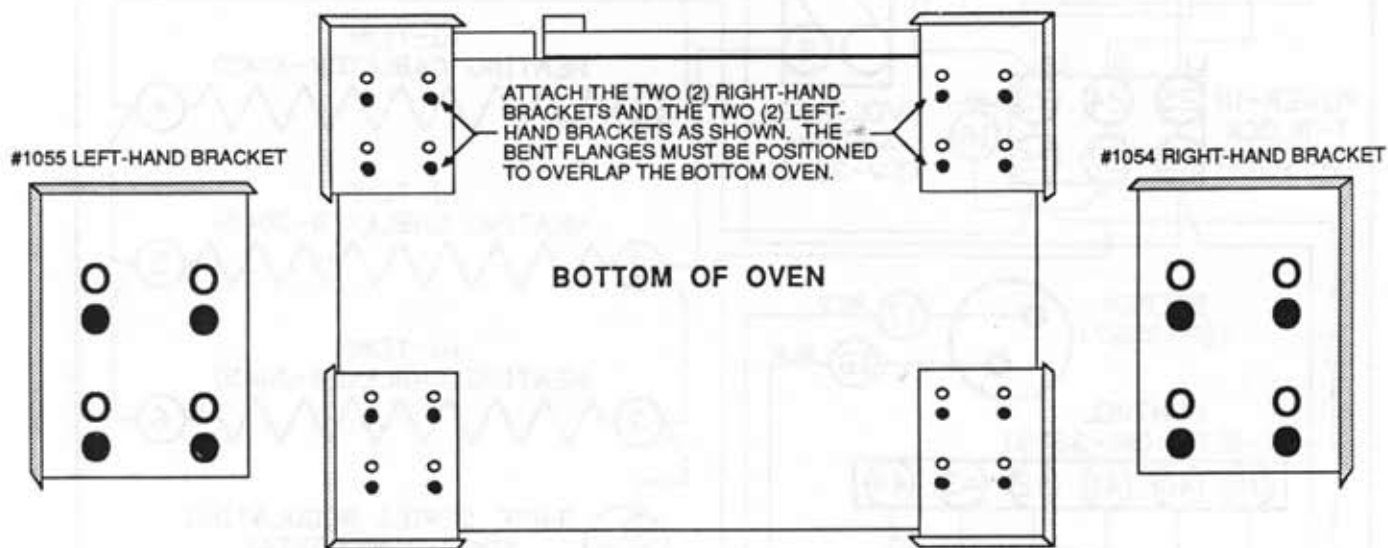

TRANSPORTATION DAMAGE and CLAIMS

All Alto-Shaam equipment is sold F.O.B. shipping point, and when accepted by the carrier, such shipments become the property of the consignee.

Should damage occur in shipment, it is a matter between the carrier and the consignee. In such cases, the carrier is assumed to be responsible for the safe delivery of the merchandise, unless negligence can be established on the part of the shipper.

1. Make an immediate inspection while the equipment is still in the truck or immediately after it is moved to the receiving area. Do not wait until after the material is moved to a storage area.
2. Do not sign a delivery receipt or a freight bill until you have made a proper count and inspection of all merchandise received.
3. Note all damage to packages directly on the carrier's delivery receipt.
4. Make certain the driver signs this receipt. If he refuses to sign, make a notation of this refusal on the receipt.
5. If the driver refuses to allow inspection, write the following on the delivery receipt:
Driver refuses to allow inspection of containers for visible damage.
6. Telephone the carrier's office immediately upon finding damage, and request an inspection. Mail a written confirmation of the time, date, and the person called.
7. Save any packages and packing material for further inspection by the carrier.
8. Promptly file a written claim with the carrier and attach ***copies*** of all supporting paperwork.

We will continue our policy of assisting our customers in collecting claims which have been properly filed and actively pursued. We cannot, however, file any damage claims for you, assume the responsibility of any claims, or accept deductions in payment for such claims.

...

ALTO-SHAAM

• • •

LIMITED WARRANTY

Alto-Shaam, Inc. warrants to the original purchaser that any original part that is found to be defective in material or workmanship will, at our option, subject to provisions hereinafter stated, be replaced with a new or rebuilt part.

The labor warranty remains in effect ninety (90) days from installation or six (6) months from the shipping date, whichever occurs first.

The parts warranty remains in effect one (1) year from installation or fifteen (15) months from shipping date, whichever occurs first.

This warranty does not apply to:

1. Equipment damage caused by accident, shipping, improper installation or alteration.
2. Equipment used under conditions of abuse, misuse, carelessness or abnormal conditions.
3. Any losses or damage resulting from malfunction, including loss of product or consequential or incidental damages of any kind.

This warranty is exclusive and is in lieu of all other warranties, expressed or implied, including the implied warranties of merchantability and fitness for purpose. In no event shall the company be liable for loss of use, loss of revenue or loss of product or profit or for indirect or consequential damages.

This warranty is in lieu of all other warranties expressed or implied and Alto-Shaam, Inc. neither assumes or authorizes any persons to assume for it any other obligations or liability in connection with Alto-Shaam equipment.

ALTO-SHAAM, INC.

...

HALO HEAT COOK / HOLD / SERVE SYSTEMS BY ALTO-SHAAM®

W164 N9221 Water St. • P. O. Box 450 • Menomonee Falls, Wisconsin 53051-0450 • U.S.A.

PHONE: (414) 251-3800 • TOLL FREE (800) 558-8744 • CANADA (800) 341-2474

TELEX (ITT) 4311070 Altsham • FAX (414) 251-7067