



ASC-2E
with
Mobile Stand Option 5004687



ASC-4E
with
Stand Option 5003489

PLATINUM SERIES

ASC-2E
ASC-4E

**Electronic
Control**

- **Installation**
- **Operation**
- **Maintenance**

W164 N9221 Water Street • P.O. Box 450
Menomonee Falls, Wisconsin 53052-0450 U.S.A.

PHONE: 262.251.3800 • 800.558.8744 U.S.A. / CANADA
FAX: 262.251.7067 • 800.329.8744 U.S.A. ONLY
www.alto-shaam.com



Consult instructions
for operation and use.



Table of Contents

| | |
|---|------------|
| Delivery | 3 |
| Transportation Damage and Claims..... | 4 |
| Unpacking | 5 |
| Safety Procedures..... | 6 |
| Installation..... | 8 |
| Dimensions | 10 |
| Accessories | 11 |
| Electrical Connection..... | 12 |
| Stacking and Venting | 13 |
| Operation..... | 16 |
| Cleaning and Preventative Maintenance | 23 |
| Troubleshooting | 25 |
| Service | 26 |
| Limited Warranty | Back cover |

This Alto-Shaam appliance has been thoroughly tested and inspected to ensure only the highest quality appliance is provided. Upon receipt, check for any possible shipping damage and report it at once to the delivering carrier. See Transportation Damage and Claims section located in this manual.

This appliance, including unattached items and accessories, may be delivered in one or more packages. Ensure all standard items and options have been received with each appliance as ordered. Save all the information packed with the appliance. Register the appliance online at www.alto-shaam.com/en/support/warranty-registration to ensure prompt service in the event of a warranty parts and labor claim.

This manual must be read and understood by all people using or installing the appliance. Contact the Alto-Shaam Tech Team Service Department if you have any questions concerning installation, operation, or maintenance.

1-800-558-8744; servicedept@alto-shaam.com

The serial number is required for all inquiries.
 Always include both model and serial number(s) in any correspondence regarding the appliance.

Model: _____

Serial number: _____

Purchased from: _____

Date installed: _____ **Voltage:** _____

CAUTION

Appliance and accessories may be heavy. To prevent serious injury, **always** use a sufficient number of trained and experienced workers when moving or leveling appliance and handling accessories.

Environmental Conditions

- Operational Environmental Conditions
- Before use, appliance must acclimate to room temperature in the environment it is placed – 24 hours is recommended.
 - Ambient temperature range of 60°F to 110°F (16°C to 43°C).
 - Relative humidity of less than 95% non-condensation.
 - Atmospheric pressure range of 50kPa to 106kPa.

Transportation Damage and Claims



All Alto-Shaam equipment is sold Free on Board (F.O.B.) shipping point, and when accepted by the carrier, such shipments become the property of the consignee.

Should damage occur in shipment, do not put the appliance into service until the damage has been inspected by an authorized Alto-Shaam service provider.

Shipping damages are a matter between the carrier and the consignee. In such cases, the carrier is assumed to be responsible for the safe delivery of the merchandise, unless negligence can be established on the part of the shipper.

1. Make an immediate inspection while the appliance is still in the truck or immediately after it is moved to the receiving area. Do not wait until after the appliance is moved to a storage area.
2. Do not sign a delivery receipt or a freight bill until a proper count has been made and inspection of all appliances are received.

3. Note all damage to packages directly on the carrier's delivery receipt.
4. Make certain the driver signs the delivery receipt. If the driver refuses to sign, make a notation of this refusal on the receipt.
5. If the driver refuses to allow inspection, write the following on the delivery receipt: **Driver refuses to allow inspection of containers for visible damage.**
6. Contact the carrier's office immediately upon finding damage, and request an inspection. Mail a written confirmation to the carrier's office with the time, date, and the person called.
7. Save any packages and packing material for further inspection by the carrier.
8. Promptly file a written claim with the carrier and attach copies of all supporting paperwork.

Alto-Shaam will continue our policy of assisting our customers in collecting claims which have been properly filed and actively pursued. Alto-Shaam cannot, however, file any damage claims, assume the responsibility of any claims, or accept deductions in payment for such claims.

Record the model and serial number of the appliance for easy reference. Always refer to both model and serial number in any contact with Alto-Shaam regarding this appliance.

Model: _____

Serial Number: _____

Date Installed: _____

Voltage: _____

Purchased From: _____



Alto-Shaam has established a twenty-four hour emergency service call center to offer immediate customer access to a local authorized service agency outside of standard business hours. The emergency service access is provided exclusively for Alto-Shaam equipment and is available throughout the United States through the use of Alto-Shaam's toll-free number. Emergency service access is available seven days a week including holidays.

- Carefully remove the appliance from the carton or crate.

NOTE: Do not discard the carton and other packaging material until you have inspected the appliance for hidden damage and tested it for proper operation.

Do not discard this manual. This manual is considered to be part of the appliance and is to be provided to the owner or manager of the business or to the person responsible for training operators. Additional manuals are available from the manufacturer.

- Read all instructions in this manual carefully before installing this appliance, using the appliance or performing routine maintenance. Following procedures other than those indicated in this guide to use and clean the appliance is considered inappropriate and may cause damage, injury or fatal accidents, in addition to voiding the warranty and relieving Alto-Shaam of all liability.
- Remove all protective plastic film, packaging materials, and accessories from the appliance before connecting electrical power. Store any accessories in a convenient place for future use.

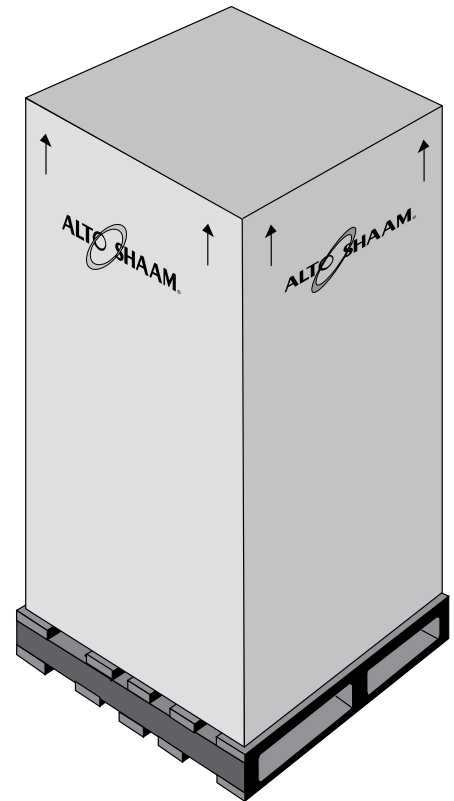

Safety Procedures

- The appliance is intended to cook, hold or process foods for the purpose of human consumption. No other use for this appliance is authorized and is therefore considered dangerous. The appliance must not be used to cook food containing flammable materials (such as food with alcohol). Substances with a low flash point can ignite spontaneously and cause a fire.
- The appliance is intended for use in commercial establishments where all operators are familiar with the purpose, limitations, and associated hazards of this appliance. Operating instructions and warnings must be read and understood by all operators and users. Alto-Shaam recommends regular staff training to avoid the risk of accident or damage to the appliance. Operators must also receive regular safety instructions.
- Any troubleshooting guides, component views, and parts lists included in this manual are for general reference only and are intended for use by qualified and trained technicians.
- This manual should be considered a permanent part of this appliance. This manual and all supplied instructions, diagrams, schematics, parts lists, notices, and labels must remain with the appliance if the item is sold or moved to another location.

NOTICE: For equipment delivered for use in any location regulated by the following directive: 2012/95/EC WEEE



Do not dispose of electrical or electronic equipment with other municipal waste.

Knowledge of proper procedures is essential to the safe operation of electrically and/or gas energized equipment. The following signal words and symbols may be used throughout this manual.

DANGER

Indicates a hazardous situation that, if not avoided, will result in death or serious injury.

WARNING

Indicates a hazardous situation that, if not avoided, could result in death or serious injury.

CAUTION

Indicates a hazardous situation that, if not avoided, could result in minor or moderate injury.

NOTICE: Indicates information considered important, but not hazard-related (e.g., messages relating to property damage).



Indicates that referral to operating instructions is a mandatory action. If not followed the operator could suffer personal injury.



Indicates that referral to operating instructions is recommended to understand operation of equipment.

- To prevent serious injury, death or property damage, the appliance should be inspected and serviced at least every twelve (12) months by an authorized service partner or trained technician.
- **Only** allow an authorized service partner or trained technician to service or to repair the appliance. Installation or repairs that are not performed by an authorized service partner or trained technician, or the use of non-factory authorized parts will void the warranty and relieve Alto-Shaam of all liability.
- When working on this appliance, observe precautions in the literature, on tags, on labels attached to or shipped with the appliance and other safety precautions that may apply.
- If the appliance is installed on casters, freedom of movement of the appliance must be restricted so that utility connections (including gas, water, and electricity) cannot be damaged when the appliance is moved. If the appliance is moved, ensure that all utility connections are properly disconnected. If the appliance is returned to its original position, ensure that retention devices and utility connections are properly connected.
- **Only** use the appliance when it is stationary. Mobile appliance racks, mobile plate racks, transport trolleys, and appliances on casters can tip over when being moved over an uneven floor or threshold and cause serious injury.
- **Always** apply caster brakes on mobile appliances or accessories when these are not being moved. These items could move or roll on uneven floors and cause property damage or serious injury.

WARNING

This appliance is not intended for use by persons (including children) with reduced physical, sensory or mental capabilities, or lack of experience and knowledge, unless they have been given supervision concerning use of the appliance by person responsible for their safety.

Children should be supervised to ensure that they do not play with the appliance.

Installation

⚠️ WARNING

Improper installation, alteration, adjustment, service, cleaning, or maintenance could result in property damage, severe injury, or death.

Read and understand the installation, operating and maintenance instructions thoroughly before installing, servicing, or operating this equipment.

⚠️ CAUTION



To prevent **personal injury** or **property damage**:

Always use hand protection when operating this appliance to avoid burns. Metal parts of this equipment become extremely hot when in operation.

CAUTION



Do not lift or move the oven by using the doors or the door handles.

⚠️ WARNING



To prevent personal injury, death or property damage:

Do not store or use gasoline or other flammable vapors or liquids in the vicinity of this or any other appliance.

The Alto-Shaam convection oven must be installed in a location that will permit the oven to function for its intended purpose and to allow adequate clearance for ventilation, proper cleaning, and maintenance.

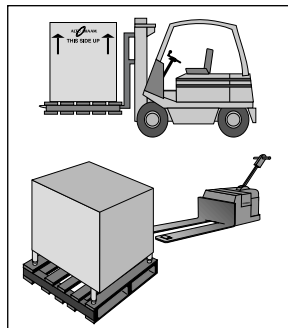

1. Hood installation is recommended (check local codes).
2. The oven must be installed on a stable and level surface.
3. **Do not** install this oven in any area where it may be affected by any adverse conditions such as steam, grease, dripping water, high temperatures, etc.
4. **Do not** store or use any flammable liquids or allow flammable vapors in the vicinity of this oven or any other appliance.
5. This appliance must be kept free and clear of any combustible materials.
6. This appliance must be kept free and clear of any obstructions blocking access for maintenance or service.

| | |
|--|------------------------------|
| ASC-2E • Weight | |
| Net: 203 lb (92 kg) | Ship: 278 lb (126 kg) |
| Crate dimensions: L x W x H 35" x 35" x 41" (889mm x 889mm x 1041mm) | |
| Minimum entry clearance: 31-1/2" (800mm) uncrated | |
| ASC-2E • Dimensions: H x W x D | |
| Exterior: 32-1/8" x 30" x 30-1/8" (815mm x 762mm x 765mm) | |
| Interior: 20" x 15" x 21" (508mm x 381mm x 533mm) | |

| | |
|--|------------------------------|
| ASC-4E • Weight | |
| Net: 490 lb (222 kg) | Ship: 535 lb (243 kg) |
| Crate dimensions: L x W x H 53" x 45" x 49" (1346mm x 1143mm x 1245mm) | |
| Minimum entry clearance: 31-1/2" (800mm) uncrated | |
| ASC-4E • Dimensions: H x W x D | |
| Exterior: 57-1/2" x 38" x 44-1/2" (1461mm x 965mm x 1130mm) | |
| Interior: 24" x 29-1/8" x 25" (610mm x 740mm x 635mm) | |

| | |
|---------------------------------------|---|
| Minimum clearance requirements | |
| | Back: 0" (0mm) |
| | Left side: 2" (51mm) |
| | Right side: 2" (51mm) |
| | From grease producing equipment: 6" (152mm) |
| | Recommended service access: 20" (508mm) right side |

The oven must be mounted on the factory equipped oven legs or on an optional oven stand. Installation on a solid or concrete base that in any way restricts air flow may void the warranty.

All clearances for a proper ventilation air supply must be maintained to minimize fire hazard. Do not locate the oven immediately adjacent to any other heat-generating appliance.

! WARNING

Improper installation, alteration, adjustment, service, cleaning, or maintenance could result in property damage, severe injury, or death.

Read and understand the installation, operating and maintenance instructions thoroughly before installing, servicing, or operating this equipment.

A number of adjustments are associated with initial installation and start-up. Adjustments must be conducted by a qualified service technician. Installation and start-up adjustments are the responsibility of the dealer or user. These adjustments include but are not limited to thermostat calibration, door adjustment, and leveling. The Platinum series oven burners are factory-adjusted with fixed air openings and require no field adjustment.

Leveling



The oven should be leveled before the gas supply is connected. Level the oven from side-to-side and front-to-back with the use of a spirit level. For ovens installed on a mobile stand, it is important that the floor surface be level due to the probability of frequent oven repositioning.

We recommend checking the level of the oven periodically to make certain the floor has not shifted nor the oven moved.

! CAUTION

Appliance and accessories may be heavy. To prevent serious injury, **always** use a sufficient number of trained and experienced workers when moving or leveling appliance and handling accessories.

**Restraint Requirements
—Mobile Equipment**

! WARNING

RISK OF ELECTRIC SHOCK.

Appliance must be secured to building structure. Failure to observe this precaution may result in damage to the equipment and severe personal injury.

Any appliance that is not furnished with a power supply cord but includes a set of casters must be provided with a tether. Adequate means must be provided to limit the movement of this appliance without depending on or transmitting stress to the electrical conduit. The following requirements apply:

1. Casters must be a maximum height of 6" (152mm).
2. Two of the casters must of be the locking type.
3. Such mobile appliances or appliances on mobile stands must be installed with the use of a flexible connector secured to the building structure.

A mounting connector for a restraining device is located on the lower back flange of the appliance chassis or on an oven stand, approximately 18" (457mm) from the floor. A flexible connector is not supplied or available from the factory.

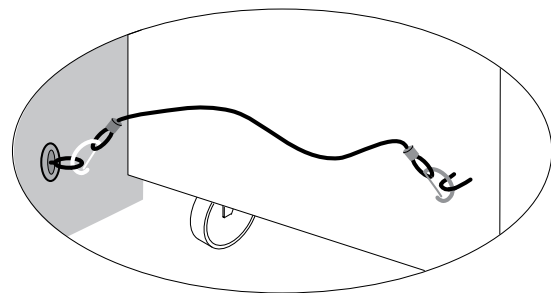

Where automatically operated appliances are vented through a ventilating hood or exhaust system equipped with a damper or with a power means of exhaust, provisions shall be made to allow the equipment to operate only when the damper is open to a position to properly vent the appliance and when the power means of exhaust is in operation. Accordance with NFPA 54 commonwealth of massachusetts only.

Dimensions

ASC-2E

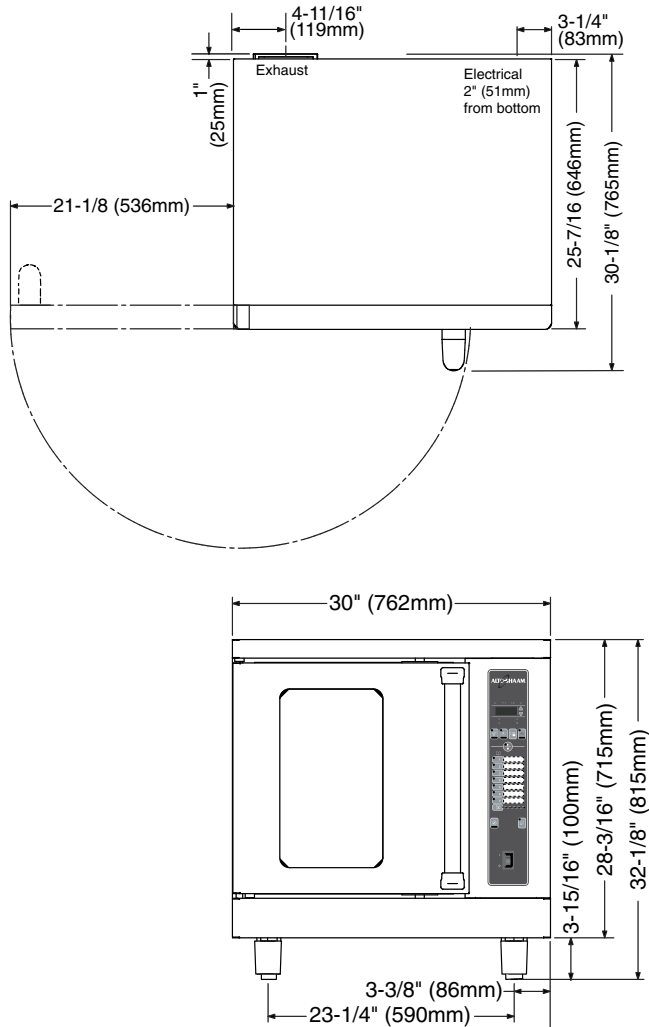

Product/Pan Capacity

27 lb (12 kg) maximum — 17 qts (15 liters)

Nine (9): 18" x 13" x 1" half-size sheet pans

5 chrome plated wire shelves with 2 removable side racks and 9 shelf positions spaced at 1-5/8" (41mm)

ASC-4E

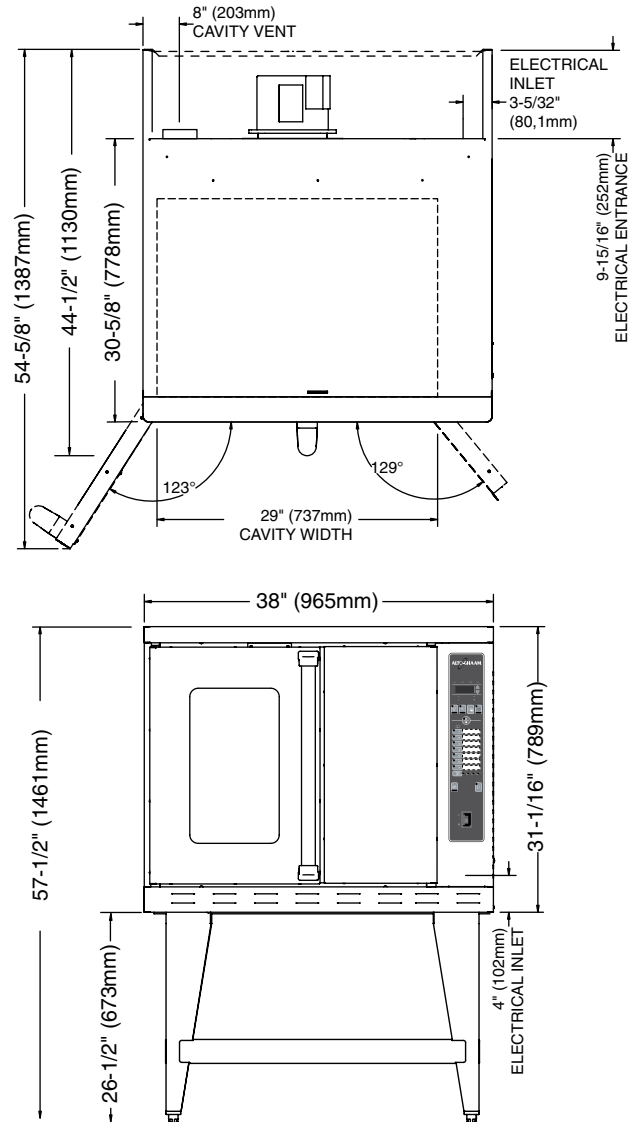

Product/Pan Capacity

72 lb (33 kg) maximum • 45 qts (43 liters)

Twelve (12): 18" x 26" x 1" full-size sheet pans

6 chrome plated wire shelves with 2 removable side racks and 12 shelf positions spaced at 1-3/4" (43mm)

| Accessories - ASC-2E | |
|---|----------|
| <input type="checkbox"/> Caster Kit, 6" (152mm) | 5013871 |
| Leg Kit, 4" (102mm) | |
| <input type="checkbox"/> Seismic feet | 5004688 |
| Leg Kit | |
| <input type="checkbox"/> with Bullet feet, 19-1/2" (495mm) height | 5005169 |
| <input type="checkbox"/> with Seismic feet, 19-1/2" (495mm) height | 5005168 |
| <input type="checkbox"/> with Casters, 23" (584mm) height | 5005181 |
| <input type="checkbox"/> Shelf, Oven Rack | SH-26894 |
| Stacking Hardware | |
| See individual stacking combination specification sheets | |
| Security Device (for correctional facility use) | |
| Includes door lock (padlock not included), security screw package, sealed rivet, security control cover | |
| | 5020698 |
| Stand, Single Oven | |
| <input type="checkbox"/> with Bullet feet, 26-1/2" (673mm) height | 5004672 |
| <input type="checkbox"/> with Seismic feet, 26-1/2" (673mm) height | 5005172 |
| <input type="checkbox"/> with Casters, 30" (762mm) height | 5004687 |

| Accessories - ASC-4E | |
|---|----------|
| <input type="checkbox"/> Caster Kit, 6" (152mm) | 5003790 |
| For mobile stack applications | |
| <input type="checkbox"/> Cooling Rack (for oven stand) | 5003791 |
| Leg Kit (4) | |
| <input type="checkbox"/> 6" (152mm) with Bullet Feet | 5003794 |
| <input type="checkbox"/> 6" (6152mm) with Seismic Feet | 5003795 |
| <input type="checkbox"/> 25" (635mm) with Seismic Feet | 5003785 |
| <input type="checkbox"/> Panel For Back , Stainless Steel | 5005876 |
| Shelf, Oven Rack | |
| <input type="checkbox"/> Interchangeable with cooling rack | SH-26795 |
| Stacking Hardware | |
| See individual stacking combination specification sheets | |
| Security Device (for correctional facility use) | |
| Includes security back panel, door locking has (padlock not included), security screw package, security control cover | |
| | 5020688 |
| Stand, Stainless Steel | |
| <input type="checkbox"/> Mobile, with Cooling Racks & Casters, 38" H (965mm) | 5003786 |
| <input type="checkbox"/> Stationary, with Cooling Racks & Bullet Feet | 5003489 |
| <input type="checkbox"/> Stationary, with Cooling Racks & Seismic Feet | 5003787 |
| Min: 34-1/4" (870mm) • Max: 35-1/2" (902mm) • H (feet are adjustable) | |

Electrical Connection

WARNING



To prevent **SERIOUS INJURY, DEATH** or **PROPERTY DAMAGE**:

All electrical connections must be made by a qualified and trained service technician in accordance with applicable electrical codes.

CAUTION



Power source must match voltage identified on appliance rating tag. The rating tag provides essential technical information required for any appliance installation, maintenance or repairs. Do not remove, damage or modify the rating tag.

WARNING



To prevent serious injury, death, or property damage:

All electrical connections must be made by a qualified and trained service technician in accordance with applicable electrical codes.



This appliance must be adequately grounded in accordance with local electrical codes or, in the absence of local codes, with the current edition of the National Electrical Code ANSI/NFPA No. 70. In Canada, all electrical connections are to be made in accordance with CSA C22.1, Canadian Electrical Code Part 1 or local codes.



CE-approved appliances include an equipotential-bonding terminal marked with the symbol shown on the left. Provisions for earthing are to be made in accordance with IEC:2010 60335-1 section 27 or local codes.

ONLY, positioning the unit so that the plug is easily accessible in case of an emergency. Arcing will occur when connecting or disconnecting the unit unless all controls are in the OFF position.

Proper receptacle or outlet configuration or permanent wiring for this unit must be installed by a licensed electrician in accordance with applicable local electrical codes.

Wire size for the main incoming power to the unit must match the minimum size listed in the specifications applicable to the specific oven model. For supply connections, locate the wire size posted on the label located near the electric terminal block behind the service panel or elsewhere listed in this manual. Before attempting the electrical connection, the rating plate should be checked to ensure that the electrical characteristics of the appliance and the electrical supply characteristics agree.

Installation of the wiring must be made in accordance with U.L. 197 Commercial Electric Cooking Appliance Standards, Local and/or National Electrical Code, ANSI / NFPA 70-1990.

Service line entry is made through the rear of the oven for connection to the terminal block. Remove the service panel on the right side of the oven for access to the terminal block.

The oven is wired at the factory for either single phase or three phase service as indicated on the original purchase order. Input voltage and phase must match the voltage and phase of the oven. Visually check all electrical connections.

The oven must be installed by a qualified electrician. This appliance must be branch circuit protected with proper ampacities, in accordance with the wiring diagram located in this manual or in the electrical compartment of the oven. The oven must be properly grounded in accordance with the National Electrical Code and applicable local codes. Plug the unit into a properly grounded receptacle

| Electrical - ASC-2E | | | | | |
|------------------------|-------|----------|-----|------|-----|
| Voltage | Phase | Cycle/Hz | Awg | Amps | Kw |
| 208 | 1 | 60 | 10 | 24.0 | 5.0 |
| 240 | 1 | 60 | 10 | 20.8 | 5.0 |
| 208 | 3 | 60 | 12 | 13.8 | 5.0 |
| 240 | 3 | 60 | 12 | 12.0 | 5.0 |
| No cord or plug | | | | | |



| Electrical - ASC-4E | | | | | |
|------------------------|-------|----------|-----|------|------|
| Voltage | Phase | Cycle/Hz | Awg | Amps | Kw |
| 208 | 1 | 60 | 6 | 50.0 | 10.4 |
| 240 | 1 | 60 | 6 | 43.3 | 10.4 |
| 208 | 3 | 60 | 8 | 28.8 | 10.4 |
| 240 | 3 | 60 | 8 | 25.0 | 10.4 |
| 440-480 | 3 | 60 | 12 | 13.6 | 10.4 |
| 220 | 1 | 50 | 6 | 40.0 | 8.7 |
| No cord or plug | | | | | |

Wire diagrams are located in the inside access panel of the unit

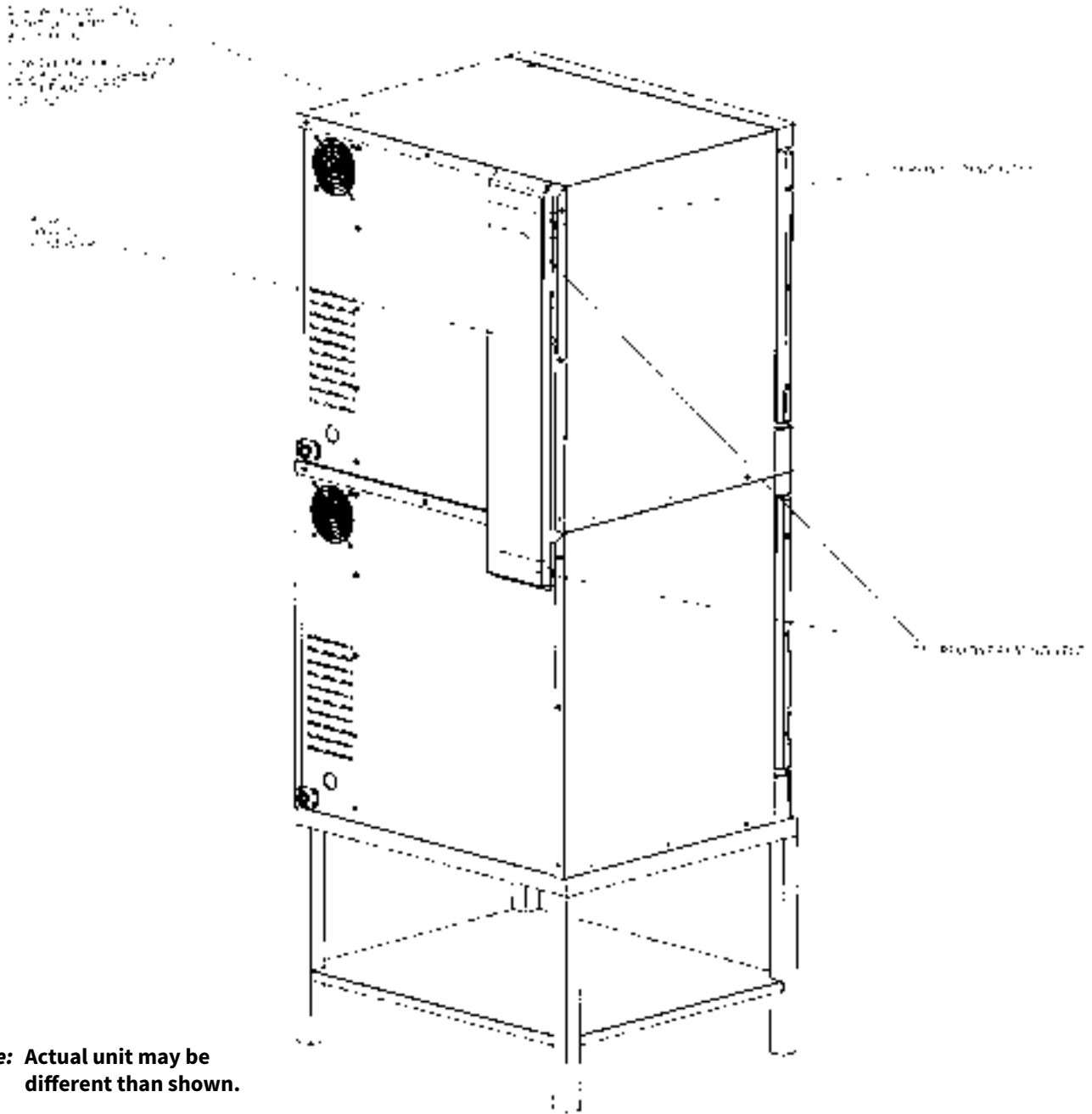
Stacking & Venting Assembly (2-ASC-2E/STK Shown)



Notice: Actual unit may be different than shown.

| | |
|--|---|
|  CAUTION | |
|  | Appliance and accessories may be heavy. To prevent serious injury, always use a sufficient number of trained and experienced workers when moving or leveling appliance and handling accessories. |

Part numbers and drawings are subject to change without notice.

Stacking and Venting

Stacking and Venting Assembly (2-ASC-4E/STK 208/240V Shown)

| Item | Description | Part No. | Qty |
|------|----------------------|--------------------------|-----|
| 1 | Riser, flue electric | 1004984 | 1 |
| 2 | Screw, #10 SMS .5LG | SC-26520 | 5 |

NOTE: Actual unit may be different than shown.

After legs or casters have been installed on the bottom oven, place the upper oven on top of lower unit. Align.

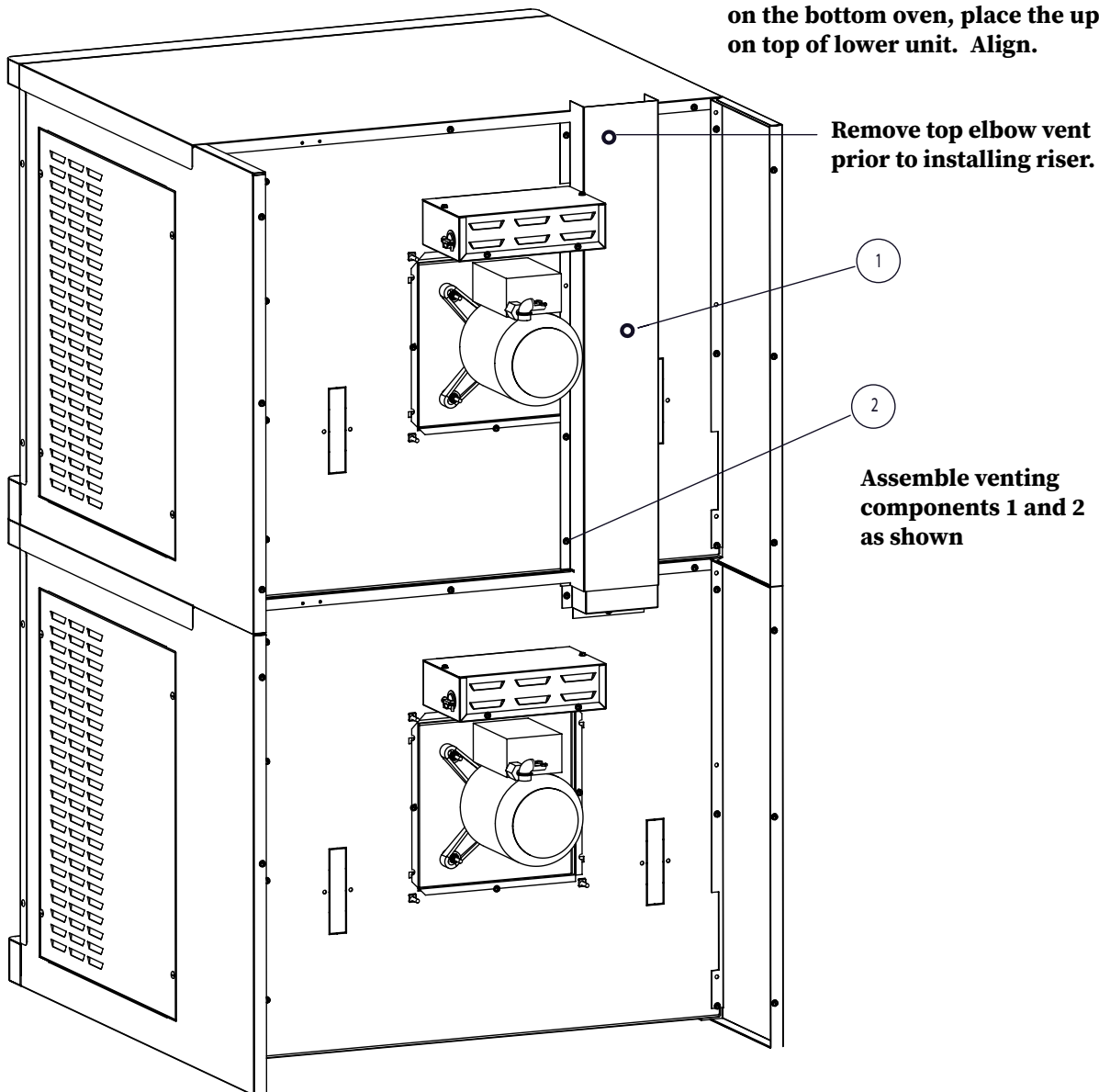

⚠ CAUTION



Appliance and accessories may be heavy. To prevent serious injury, **always** use a sufficient number of trained and experienced workers when moving or leveling appliance and handling accessories.

Part numbers and drawings are subject to change without notice.

Oven Stand Assembly

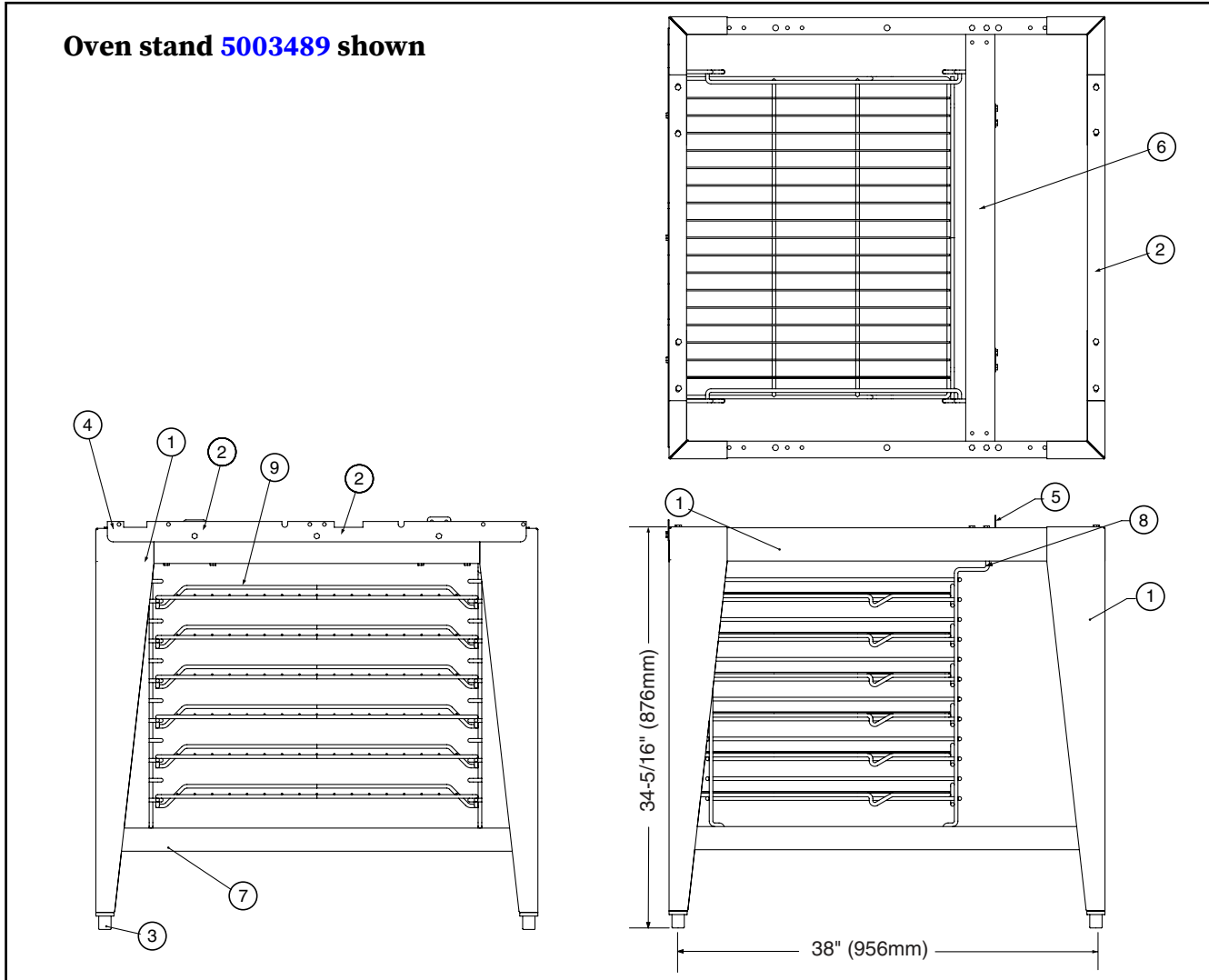

| Item | Description | Part No. | Qty |
|------|------------------------------------|----------|-----|
| 1 | Leg Support Assembly | 5003488 | 2 |
| 2 | Channel, Support | 1004459 | 2 |
| 3 | Leg | LG-22185 | 4 |
| * | Casters, Rigid | CS-25674 | 2 |
| * | Casters, Swivel W/Brake | CS-25675 | 2 |
| 4 | Bracket, Stand | 1004461 | 1 |
| 5 | Bracket, Attachment | 1004369 | 2 |
| 6 | Channel, Back | 1004460 | 1 |
| 7 | Shelf, Stand | 1004466 | 1 |
| 8 | Rack, Oven Support | SR-26551 | 2 |
| 9 | Oven Rack | SH-26795 | 6 |
| 10* | Screws, 1/4-20 X 1/2 Hex Head | SC-22729 | 27 |
| 11* | Nut, 1/4-20 Nylon Insert, 18-8 S/S | NU-23984 | 27 |
| 128 | Lock Washer, 1/4" Stainless Steel | WS-2294 | 27 |

*Not shown

Part numbers and drawings are subject to change without notice.

Operation

Start-Up Operation

| | |
|--|--|
|  CAUTION | |
|  | To prevent personal injury or property damage : |
| | Always use hand protection when operating this appliance to avoid burns. Metal parts of this equipment become extremely hot when in operation. |

This appliance is intended for use in commercial establishments by qualified operating personnel where all operators are familiar with the purpose, limitations, and associated hazards of this appliance. Operating instructions and warnings must be read and understood by all operators and users.

Before initial use:

Interior oven surfaces must be heated to remove surface oils and the accompanying odor produced during the first use of the oven.

1. Wipe all wire shelves, side racks and the full oven interior with a clean, damp cloth.

In the event of a power failure:

- Turn all switches off.
- Wait until power is restored before attempting to operate the oven.

NOTICE: If such an event has occurred, it is strongly recommended that you ensure the food in the oven is safe for consumption according to local health regulations.

2. Close the oven doors, press the power switch to the **ON** position, and set the thermostat to 300°F (149°C).
3. Allow the oven to cycle for approximately 2 hours or until no odor is detected.

Preheating:

Always preheat a cold oven for a minimum of 20 minutes before cooking product. Follow the operating instructions indicated on the next few pages of this manual.

Pan/Shelf Positions For AAS-2E:

The oven includes 5 chrome plated wire shelves with two removable side racks and 9 shelf positions spaced at 1-5/8" (41mm).

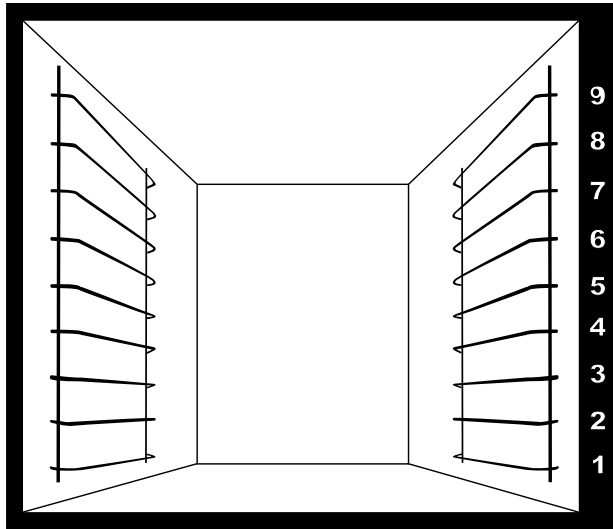

1. POSITION The best arrangement for broiling, baking cookies and for other baked goods under 2-1/2" (65mm) in height. This arrangement can also be used as the maximum capacity for reconstituting frozen entrées.
 - 2
 - 4
 - 6
 - 8
2. POSITION General baking with the use of sheet pans for products under 3-1/2" (89mm) in height. Products include cakes, pies, muffins, or extended dishes in 20" x 12" x 2-1/2" deep pans (530mm x 325mm x 65mm GN 1/1).
 - 1
 - 4
 - 7
3. POSITION Ideal positions for baking bread, meringue, or extended dishes and roasts in pans not to exceed 5-1/2" (140mm) in height.
 - 1
 - 5
4. POSITION Arrangement necessary for roasting whole turkey or roasts up to 7" (178mm) in height.
 - 1
 - 6

Pan/Shelf Positions For ASC-4E:

The oven includes 6 chrome plated wire shelves with two removable side racks and 12 shelf positions spaced at 1-3/4" (43mm).

1. POSITION The best arrangement for broiling, baking cookies and for other baked goods under 2-1/2" (65mm) in height. This arrangement can also be used as the maximum capacity for reconstituting frozen entrées.
 - 2
 - 4
 - 6
 - 8
 - 12
2. POSITION General baking with the use of sheet pans for products under 3-1/2" (89mm) in height. Products include cakes, pies, muffins, or extended dishes in 20" x 12" x 2-1/2" deep pans (530mm x 325mm x 65mm GN 1/1).
 - 1
 - 4
 - 7
 - 10
3. POSITION Ideal positions for baking bread, meringue, or extended dishes and roasts in pans not to exceed 5-1/2" (140mm) in height.
 - 1
 - 5
 - 9
4. POSITION Arrangement necessary for roasting whole turkey or roasts up to 7" (178mm) in height.
 - 1
 - 6

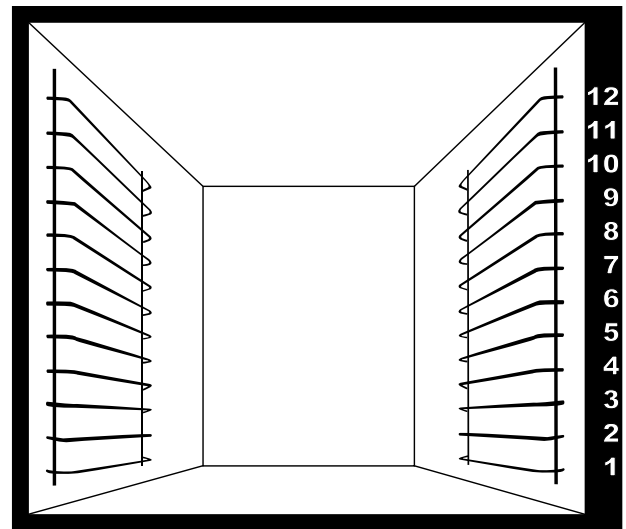

CAUTION

To prevent **personal injury** or **property damage**:

Always use hand protection when operating this appliance to avoid burns. Metal parts of this equipment become extremely hot when in operation.

Operation

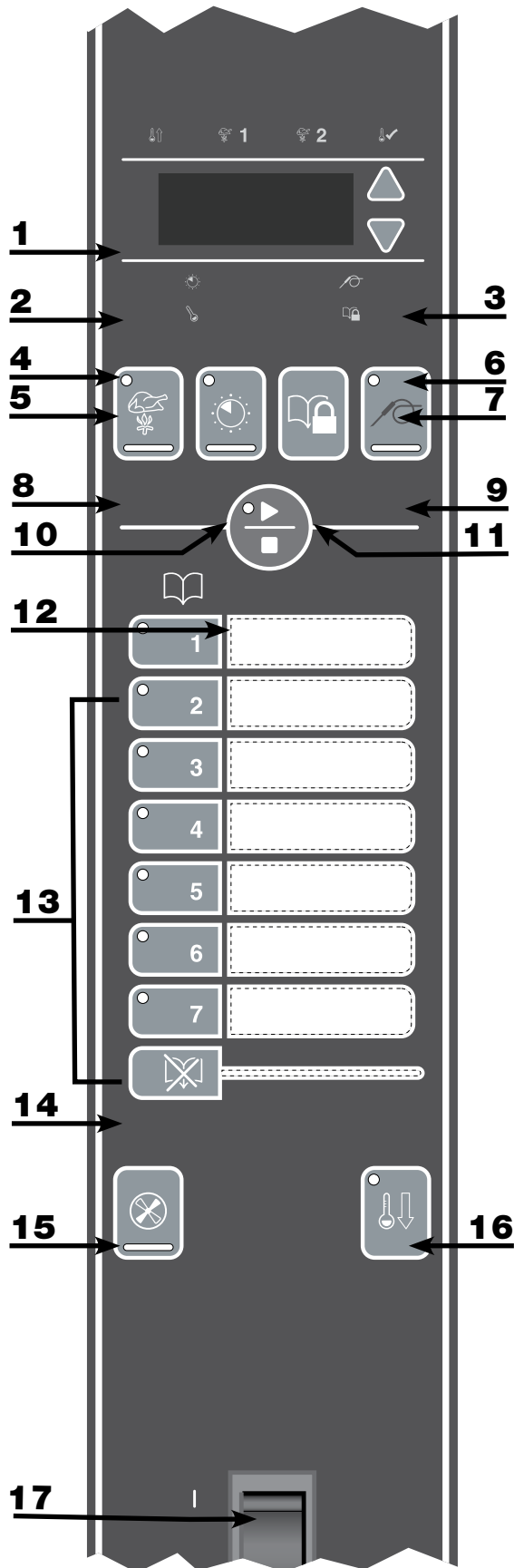

Control Identification

- 1** Preheat Indicator
- 2** Led Display
- 3** Up/Down Arrows
- 4** Cook Indicator
- 5** Temperature Indicator
- 6** Probe Indicator
- 7** Preset Lock Indicator
- 8** Cook Key
- 9** Probe Key
- 10** Time Key
- 11** Preset Lock Key
- 12** Start/Stop Key
- 13** Preset Keys 1-7
- 14** Cancel Key
- 15** Fan Speed Key
- 16** Cool Down Key
- 17** Main Power Switch

A. Push the Main Power (17) ON.

- The **Display (2)** will alternate between last cook set temperature and actual cavity temperature.
- The oven will preheat to previous cook temperature, and the **Preheat (1)** indicator will illuminate.

To terminate procedure,
push **Start/Stop (12)** button twice.

B. If the previous cook cycle is acceptable, proceed to step C.

- **To cook by time:**
 - Push **Cook (8)**.
 - Push **Time (11)**.
 - Confirm fan speed.
 - Adjust the cooking temperature with the **Up/Down (4)** arrows. The **Time (11)** indicator will remain lit.
- **To cook by probe (optional):**
 - Push **Cook (8)**.
 - Push **Probe (11)**.
 - Confirm fan speed.
 - Adjust the cooking temperature with the **Up/Down (4)** arrows. The **Probe (11)** indicator will remain lit.

Note: If more than 5 seconds elapse before a decision is made, the mode button must be pushed again to continue.

C. When the cook preheat temperature has been reached:

- The **Start/Stop (12)** and **Ready Indicator (1)** will flash.
- The control will produce an audible beep every 30 seconds.
- **Load product in a timely manner.**
 - **To cook by time:**
 - When cooking by **Time (4)**, the **Display (2)** will alternate between cook temperature and remaining time.

- **To cook by probe (optional):**

- If cooking by probe, remove probe from its bracket, wipe the probe tip with a disposable alcohol pad and properly insert probe into product.
- When cooking by **Probe (11)**, the **Display (2)** will alternate between cook temperature, probe temperature, and elapsed time.

2. Close the oven door -- push Start/Stop (12).**3. After cook cycle is complete and product is ready:**

- The **Display (2)** will indicate "DONE".
- The **Start/Stop (12)** button and **Ready Indicator (1)** will flash.
- The control will produce an audible beep every 30 seconds.

4. Remove product promptly to avoid overcooking.

To terminate procedure,
push **Start/Stop (12)** button twice.

D. Cooling the oven:

- Open door.
- Push the **Cool Down (16)** button.
 - **Cool continuously**
 - Fan will run continuously.
 - Shut off POWER to terminate.
 - **Set cool down temperature**
 - Set desired cool down temperature with **Up/Down (4)** arrows. The cool down temperature ranges from 80° to 450°F.
 - Fan will run continuously.
 - When the desired cool down temperature is reached, **Display (2)** will indicate "COOL/STOP".
 - The control will produce an audible beep every 30 seconds.

Note: If more than 5 seconds elapse before a decision is made, the mode button must be pushed again to continue.

Start/Stop (12) will stop fan and terminate the **Cool Down (16)** feature.

E. At the end of the day, shut off oven power before leaving the premises.

Operation

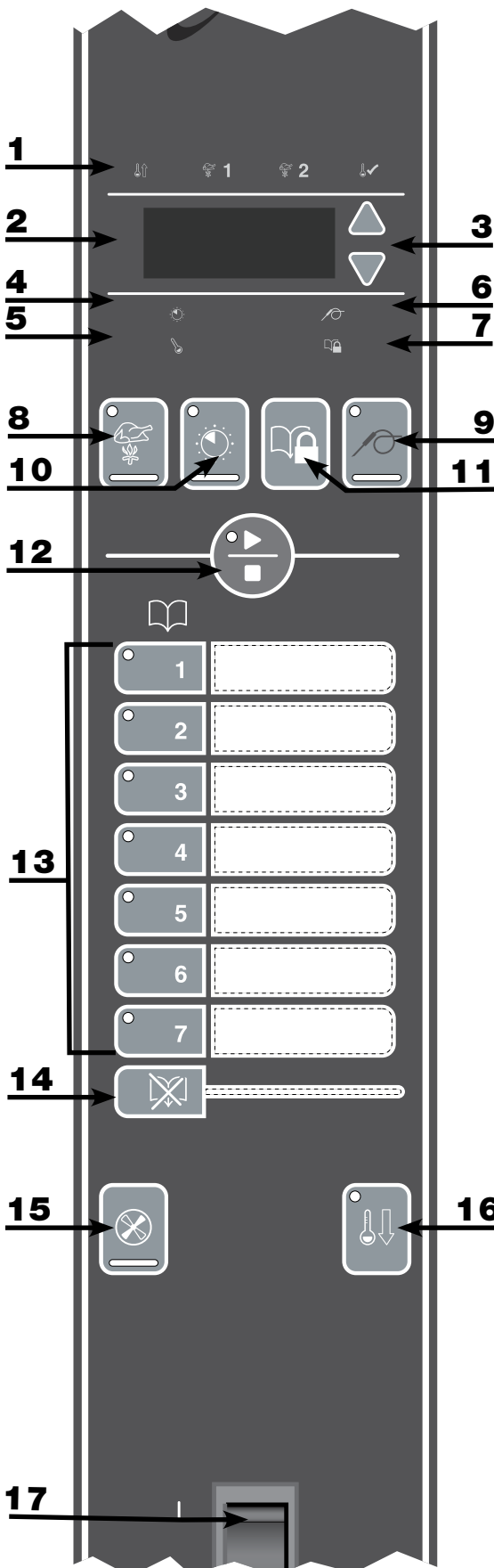

Menu Presets

Programming

This Alto-Shaam electronic convection oven allows the operator to program up to seven cooking procedures. Each cooking program entered can be preset in any program function to cook by time (or probe, if a probe is included on the oven). Cooking programs are stored and recalled with the **Presets (13)** buttons labeled 1 through 7.

Push the **Main Power (17)** ON.

- The **Display (2)** will alternate between last cook set temperature and actual cavity temperature. The oven will begin preheating and the **Preheat Indicator (1)** will illuminate. The fan will operate at high speed "FnHi".

Follow instructions listed on the previous pages of this manual.

Push and hold selected **Preset (13)** (1 through 7) for 4 seconds.

- A beep sounds.
- The numbered button indicator light will illuminate.

The programmed procedure is now stored in memory for the specific number button selected. To lock a **Preset (13)** (1 through 7), push **Preset Lock (11)** simultaneously with the up arrow. To unlock, push the **Preset Lock (11)** simultaneously with the down arrow.

At this point, push **Start/Stop (12)** twice. This will protect the **Preset (13)** in case of a power outage.

Important

After programming a specific product into the memory of a preset, it is very important to make a written permanent record of the product and the program letter assigned.

Erasing A Program

To erase a program, the oven must be in the preheat mode. The oven cannot be running a preset menu program.

- When the oven is in the preheat mode, push and hold both the **CANCEL (14)** and the appropriate number **Preset (13)** to be erased. Hold both keys until the oven double beeps, and the program's indicator light goes out. This indicates the program has been erased.

Cook — Using Preset Menu Keys

- Push desired **Preset (13)** (1 through 7). Preheat will begin.
- The oven will beep when the preheat temperature has been reached.
- Load food inside the oven. **If cooking by probe, remove probe from its bracket, wipe the tip with a disposable alcohol pad and insert probe properly into product.**
- Close the oven door.
- Push **Start/Stop (12)**.

Stop an operation:

Push **Start/Stop (12)**. The oven will remain in a power-on state, and the operation will be cancelled. Push **Cook (8)** to set procedure again.

Adding product after start:

If the door is opened during cook cycle, the heater, fan, and timer will disengage. "Door" will illuminate in the display. The timer will be held to the last value at the point of interruption. The oven will continue operation from the point of interruption when the door is closed.

Arrows:

Used to increase or decrease set time, including cooking, holding, and probe temperature settings.

To run oven continuously at a set temperature:

Set **Cook (8)** temperature, set **Time (10)** to "--:--". The oven will run continuously at that set temperature. The display will alternate between the set temperature and "--:--", signifying continuous cooking. The operator is then responsible for timing the cooking loads. To disengage, push **Start/Stop (12)**.

Fan Speed:

The fan speed can be adjusted to high or low during any preheat or cook cycle (including **Presets (13)**). When high speed is selected, the underscore bar below **Fan Speed (15)** will illuminate. The display will indicate "FnHi". When low speed is selected, the underscore bar below **Fan Speed (15)** will not be illuminated. The display will indicate "FnLo".

NOTE: The time and temperature can be adjusted during the cooking mode, (unless a preset program is used).

Probe Usage:

When the oven probe remains inserted in the probe bracket, the LED temperature display will indicate the ambient air temperature inside the oven. To use the probe for cooking remove it from the bracket and wipe the full length of the metal probe with a disposable alcohol pad to clean and sanitize before using.

Only the tip of the probe senses the internal product temperature; therefore, it is important the tip be placed correctly in the product for internal temperature accuracy. Push the probe tip halfway into the product, positioning the tip at the center of the food mass. When inserting the probe into solid foods such as meat roast or poultry breasts, push the probe in from a straight downward position or in from the side to the center position. If placing into a semi-liquid or liquid product, the probe cable must be secured to keep the probe positioned properly. Do not let the probe tip touch the edges, bottom or side of a container. Tape the probe cable to the lip or edge of the container.

NOTICE: When cooking by probe, insert the probe into the raw product after the oven has been preheated.

Wait one full minute to allow the probe temperature to decrease to the internal temperature of the product. Push the start button to begin the cooking process after this probe temperature adjustment period. A false probe reading of the internal product temperature will cause the oven to default to a holding temperature.

Probe Calibration:

1. To verify product probe calibration, place the probe in a glass of ice water.
2. After allowing the temperature to settle, push the probe button for five (5) seconds. Compare reading against 32°F (0°C).
3. If calibration is required, the unit must be in the power up hold mode. From the off state turn the unit on. The unit will begin to operate in the power up hold mode, push the probe button for eight (8) seconds until the unit beeps twice and a temperature is displayed. Adjust the probe offset temperature by pushing the up or down arrows to increase or decrease the temperature. Repeat step 2 to verify.
4. Repeat steps 1 and 2 to verify the probe calibration as necessary.

Operation

Chef Operating Tips

The Alto-Shaam convection oven will provide the best results and longest possible service with the utilization of the following suggestions and guidelines.

NOTICE: Moisture will escape around the doors when baking products with a heavy moisture content such as chicken, potatoes, etc. This is a normal operating condition.



1. Thoroughly preheat the oven for approximately 20 minutes before use.
2. As a general rule, the cooking temperature can be set lower than the temperature used in a conventional oven. Cooking time may also be shorter. It is suggested the first batch of each product prepared be monitored closely to check for variances.
3. Maintain a record of the temperatures, times, and load capacities established for products cooked on a regular basis since they will be the same or similar for succeeding loads.
4. When practical, start cooking the lowest temperature products first and gradually work up to products with a higher cooking temperature.
5. If the cooking temperature setting for the previous product is more than 10°F (5°C to 6°C) higher than the temperature needed for the next load, use the Fan Cool-Down feature to decrease the oven temperature before setting the oven to a lower temperature.
6. Work as quickly as possible when loading the oven to prevent heat loss.
7. When the audible signal indicates the time has expired, remove the food product from the oven as quickly as possible to avoid over cooking.
8. Pans should be centered between side racks and each shelf should be loaded evenly to allow proper air circulation within the oven compartment.
9. To ensure even cooking when baking, weigh or measure the product in each pan.
10. **ASC-2E:** When cooking five pans of product, start from the bottom of the oven and use side rack positions 1, 3, 5, 7, and 9.
ASC-4E: When cooking six pans of product, start from the bottom of the oven and use side rack positions 2, 4, 6, 8, 10, and 12.
11. Do not overload the oven. Refer to product/pan capacities indicated in this manual.
12. To obtain an evenly baked product, muffin pans should be placed in the oven with the short side of each pan facing the front of the oven.
13. When rethermalizing frozen casseroles, preheat the oven 100°F (38°C) over the suggested temperature to compensate for the introduction of a large quantity of frozen product into the oven compartment. Reset the thermostat to the correct cooking temperature after the oven is loaded.
14. Use a pan extender or 2" (51mm) deep, 18" x 26" pans for batter-type products that weigh more than 8 lbs (3 to 4 kg), i.e. pineapple upside-down cake.
15. To avoid obstructing airflow that would result in uneven cooking, never place anything directly on the bottom of the oven cavity.

| Cooking Guidelines | | | | | | | |
|---|-------------|-------|----------------|---------------------------------------|-------------|-------|----------------|
| Food | Temperature | | Time (Minutes) | Food | Temperature | | Time (Minutes) |
| Cakes, Sheet | 325°F | 163°C | 25 | Macaroni & Cheese (Frozen, full oven) | 350°F | 177°C | 90 |
| Chicken pieces (30 breasts & thighs, 25 legs & wings) | 400°F | 204°C | 25 | Macaroni & Cheese (Refrigerated) | 350°F | 177°C | 30 |
| Chicken halves | 400°F | 204°C | 40 | Muffins | 325°F | 163°C | 13-15 |
| Beef patties | 400°F | 204°C | 8 | Pies, Frozen | 325°F | 163°C | 40 |
| Bacon | 350°F | 177°C | 16 | Pizzas, Individual | 325°F | 163°C | 15 |
| Fish, frozen (5 oz.) | 350°F | 177°C | 15 | Potatoes, Baked | 350°F | 177°C | 50 |
| Macaroni & Cheese (Frozen, 1 pan) | 350°F | 177°C | 50 | Sandwiches, Grilled Cheese | 400°F | 204°C | 4-6 |
| | | | | Tater tots | 450°F | 232°C | 10 |

At the end of the day, utilize the cool-down mode and open the oven doors.

Do not place anything directly on the bottom of the oven cavity.

Protecting Stainless Steel Surfaces



It is important to guard against corrosion in the care of stainless steel surfaces. Harsh, corrosive, or inappropriate chemicals can completely destroy the protective surface layer of stainless steel. Abrasive pads, steel wool, or metal implements will abrade surfaces causing damage to this protective coating and will eventually result in areas of corrosion. Even water, particularly hard water that contains high to moderate concentrations of chloride, will cause oxidation and pitting that result in rust and corrosion. In addition, many acidic foods spilled and left to remain on metal surfaces are contributing factors that will corrode surfaces.

Proper cleaning agents, materials, and methods are vital to maintaining the appearance and life of this appliance. Spilled foods should be removed and the area wiped as soon as possible but at the very least, a minimum of once per day. Always thoroughly rinse surfaces after using a cleaning agent and wipe standing water as quickly as possible after rinsing.

Cleaning Agents

Use non-abrasive cleaning products designed for use on stainless steel surfaces. Cleaning agents must be chloride-free compounds and must not contain quaternary salts. Never use hydrochloric acid (muriatic acid) on stainless steel surfaces. Failure to observe this precaution will void the warranty. Always use the proper cleaning agent at the manufacturer's recommended strength. Contact your local cleaning supplier for product recommendations.

Cleaning Materials

Cleaning can usually be accomplished with the proper cleaning agent and a soft, clean cloth. When more aggressive methods are needed, use a non-abrasive scouring pad on difficult areas and make certain to scrub with the visible grain of surface metal to avoid surface scratches. Never use wire brushes, metal scouring pads, or scrapers to remove food residue. Failure to observe this precaution will void the warranty.

NOTICE



To protect stainless steel surfaces, completely avoid the use of abrasive cleaning compounds, chloride based cleaners, or cleaners containing quaternary salts. **Never** use hydrochloric acid (muriatic acid) on stainless steel. **Never** use wire brushes, metal scouring pads or scrapers.

! WARNING



To prevent **serious personal injury, death, or property damage:**

The appliance must be cleaned thoroughly to avoid deposits of grease and or food residue inside the appliance that may catch fire. If fat deposits and/or food waste inside the appliance ignite, shut down the appliance immediately and keep the appliance door closed to extinguish the fire. If further extinguishing is required, disconnect the appliance from the main power and use a fire extinguisher (do not use water to extinguish a grease fire!). Failure to clean the appliance properly invalidates the warranty and relieves Alto-Shaam of all liability.

Cleaning and Preventative Maintenance

⚠ WARNING



To prevent serious personal injury, death, or property damage:

Do not steam clean, hose down or flood the interior or exterior with water or liquid solution of any kind. **Do not** use water jet to clean. Failure to observe this precaution will void the warranty.

The oven is fabricated with an easy to clean porcelain enamel interior or an optional stainless steel interior.

NOTICE: Always allow the oven to cool before cleaning. If the oven is hot, allow the interior surfaces to become cool to the touch by opening the oven doors and engaging the cool down function.

Do not use abrasive cleaning compounds.

Completely avoid the use of abrasive cleaning compounds, chloride-based cleaners, or cleaners containing quaternary salts. To protect metal finish on stainless steel, never use hydrochloric acid (muriatic acid).

Clean The Oven On A Daily Basis

1. After the oven has cooled, remove all detachable items such as wire shelves, side racks, and drip pan. Clean these items separately.
2. Remove any food scraps from shelves, shelf supports, and blower fan wheel. Convection baffle openings must be kept clear of food scraps and grease.
3. Wipe the interior metal surfaces of the oven with a paper towel to remove any remaining food debris.
4. Clean interior with a damp cloth or sponge and any good commercial detergent at the recommended strength.
5. For baked-on food deposits, use a non-caustic and non-toxic commercial oven cleaner appropriate for the interior oven surface of your oven. Follow the product manufacturer's instructions carefully for the use of this product. Any commercial oven cleaner must be approved for use on food contact areas. Remove soil with the use of a plastic scouring pad.

⚠ WARNING



To prevent serious injury, death, or property damage, **always** disconnect the appliance from the power source before cleaning or servicing.

6. Wipe door gaskets thoroughly since these areas harbor food debris and grease.
7. Rinse surfaces by wiping with a clean cloth or sponge and clean warm water.
8. Remove excess water with a sponge and wipe dry with a clean cloth or air dry. Leave doors open until interior is completely dry. Replace side racks and shelves.

Always follow appropriate state or local health (hygiene) regulations regarding all applicable cleaning and sanitation requirements for food service equipment.

Exterior

To help maintain the protective film coating on polished stainless steel, clean the exterior of the cabinet with a cleaner recommended for stainless steel surfaces. Spray the cleaning agent on a clean cloth and wipe with the grain of the stainless steel.

Wipe control panel, door vents and door handles, thoroughly since these areas harbor food debris.

Clean exterior glass surfaces with a commercial window cleaner.

Do not use abrasive cleaning compounds

Motor Care

The convection oven motor contains self-lubricating, sealed ball bearings and is generally maintenance-free. During operation, the interior of the motor is cooled by air flowing into the rear of the motor case. This is a general operating feature when proper clearances have been allowed.

At the end of the day, utilize the cool-down mode and open the oven doors.

| Code | Description | Possible Causes |
|--|---|---|
| E-10 | Cavity air sensor shorted | Cavity air sensor reading < 5°F (-15°C). Verify sensor integrity. |
| E-11 | Cavity air sensor open | Cavity air sensor reading > 517°F (269°C). Verify sensor integrity. |
| E-20 | Product probe is shorted <i>Oven will cook in time only</i> | Product probe reading < 5°F (-15°C). Verify sensor integrity. |
| E-21 | Product probe is open <i>Oven will cook in time only</i> | Product Probe reading > 517°F (269°C). Verify sensor integrity. |
| E-30 | Under temperature | Unit has been more than 25°F (14°C) below set point for longer than 90 minutes. |
| E-31 | Over temperature | Unit has been more than 60°F (33°C) above the maximum set-point for longer than 3 minutes. Holding Cabinets with this error code are more than 145°F (81°C) above the maximum set-point. |
| E-32 | Safety switch open (Aux hi-limit switch) | Contact factory. |
| E-38 | Internal software error | Contact factory. |
| E-39 | Sensor error | Contact factory. |
| E-50 | Temp. measurement error | Contact factory. |
| E-51 | Temp. measurement error | Contact factory. |
| E-60 | Real time clock error | Data set to factory default. Ensure that date and time are correct if applicable. |
| E-61 | Real time clock error | Contact factory. |
| E-64 | Clock is not oscillating | Contact factory. |
| E-70 | Configuration connector error (DIP switch) | Refer to wiring diagram for the particular model and ensure dip switches on the control match the settings called out on the WD. If the dip switch settings are correct according to the print replace the control. |
| E-78 | Voltage low | Voltage below 90 VAC on a 125 VAC unit, or below 190 VAC on a 208-240 VAC unit. Correct voltage. |
| E-79 | Voltage high | Voltage over 135 VAC on a 125 VAC unit, or over 250 VAC on a 208-240 VAC unit. Correct voltage. |
| E-80 | EEPROM Error | Ensure that all temperatures and times are properly set. Contact factory if problem persists. |
| E-81 | EEPROM Error | Contact factory. |
| E-82 | EEPROM Error | Contact factory. |
| E-83 | EEPROM Error | Contact factory. |
| E-85 | EEPROM Error | All timers, if previously on, are now off. Possible bad EEPROM. |
| E-86 | EEPROM Error | Stored HACCP memory corrupted. HACCP Address reset to 1. Possible bad EEPROM. Contact factory if problem persists. |
| E-87 | EEPROM Error | Stored offsets corrupted. Offsets reset to 0. Control may need a recalibration. Possible bad EEPROM. Contact factory if problem persists. |
| E-88 | EEPROM Error | All timer set-points are reset to 1 minute. Timers, if previously on, are now off. Possible bad EEPROM. |
| E-90 | Button stuck | A button has been held down for > 60 seconds. Adjust control. Error will reset when the problem has been resolved. |
| E-91 | Input failure | Contact factory. |
| E-dS | Datakey error | Datakey digital signature incompatible. Cycle power, and install compatible Datakey if error persists. |
| E-dT | Datakey error | Datakey incompatible with control. Install compatible Datakey. |
| E-dU | Datakey unplugged | Install Datakey and cycle power to control to clear error. |
| dLto | Datalogger has timed out | Cycle power. Contact factory if error persists. |
| dLSD | Micro SD card not plugged in | Plug in SD card and cycle power. Contact factory if error persists. |
| NOTE: If in doubt, always cycle the power to the control and contact factory if the problem persists. | | |

Service

Full Assembly - ASC-2E

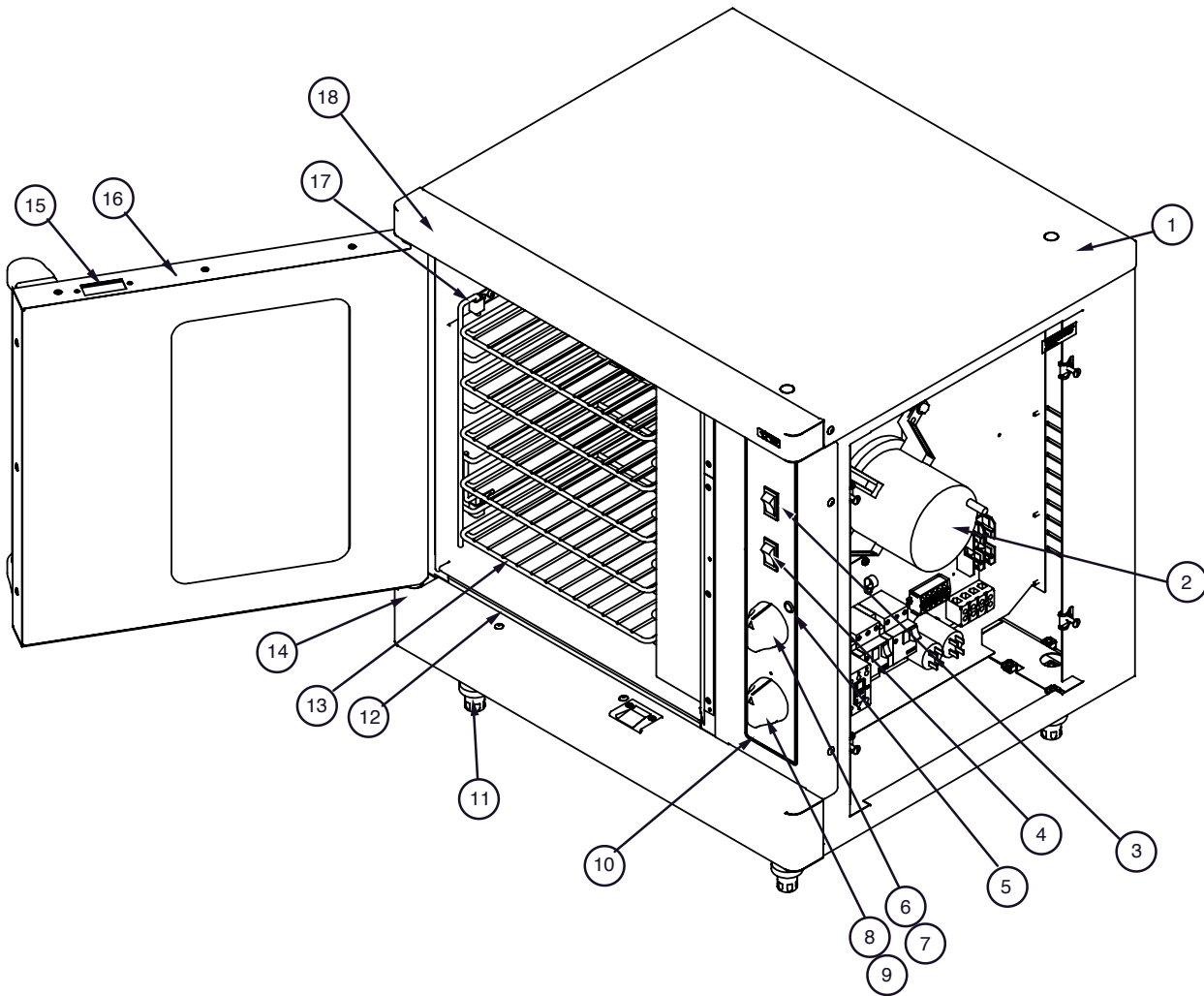

| Item | Description | Part No. | Qty |
|------|--------------------------|---------------------------------------|-----|
| 1 | Panel, top and side | 1005455 | 1 |
| 2 | Motor | MO-34208 | 1 |
| 3 | Panel overlay | PE-26977 | 1 |
| 4 | Switch, ON/OFF/cool down | SW-34112 | 1 |
| 5 | Feet | See page 11 | 4 |
| 6 | Oven rack | SH-26894 | 5 |
| 7 | Gasket | Top/Bottom 1005316 | 2 |
| | | Side 1005311 | 2 |
| 8 | Cover, bottom hinge | 1005458 | 1 |
| 9 | Latch | LT-26976 | 2 |
| 10 | Door assembly | DR-27848 | 1 |
| 11 | Side rack | SR-26893 | 2 |
| 12 | Cover, top hinge | 1005459 | 1 |

Control Assembly - ASC-2E

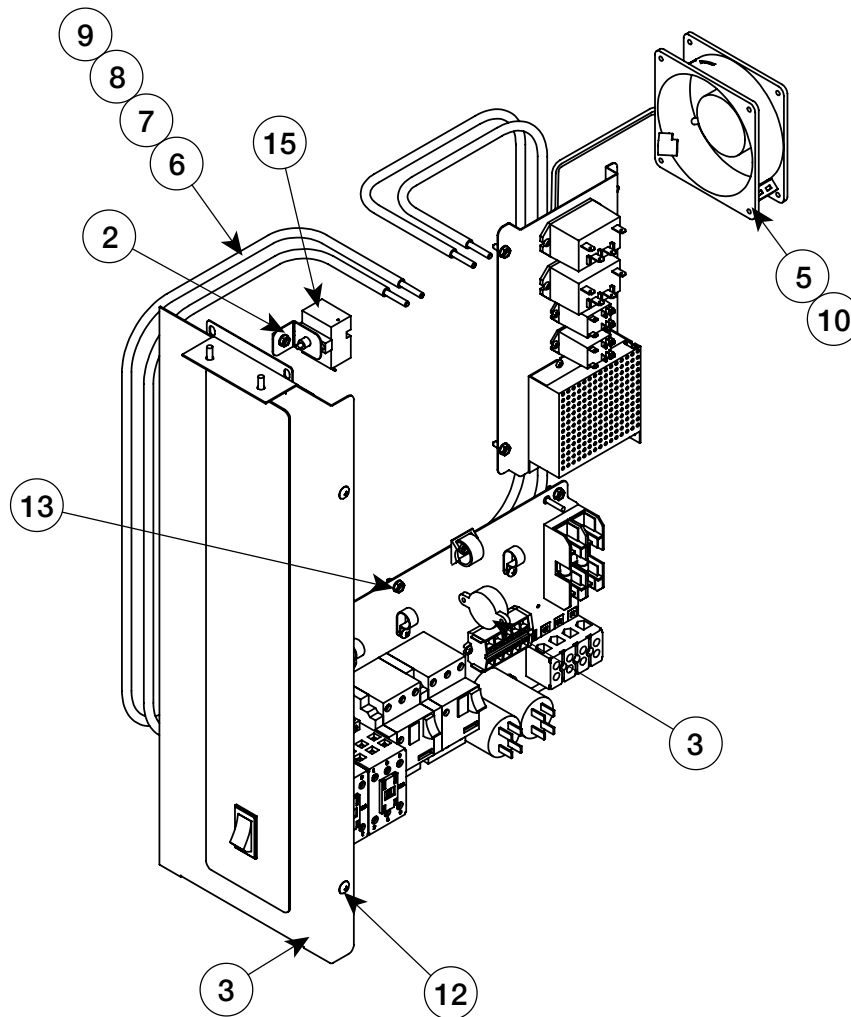

| Item | Description | Part No. | Qty |
|------|---|-----------------------|-----|
| 1* | Guard sensor | 1493 | 1 |
| 2 | High limit switch bracket | 1012678 | 1 |
| 3 | Control assembly, electronic ASC-2E | 5005353 | 1 |
| 4* | Block, mtg, snsr | BK-24427 | 1 |
| 5 | Cord for 4" box fan | CD-33338 | 1 |
| 6* | Element, inner 2.5kW | 240V EL-34209 | 1 |
| 7* | Element, outer 2.5kW | 240V EL-34210 | 1 |
| 8 | Element, outer 2.5kW | 208V EL-34211 | 1 |
| 9 | Element, inner 2.5kW | 208V EL-34212 | 1 |
| 10 | Fan housing, 119mm x 119mm x 38mm | FA-3568 | 1 |
| 11* | Screw, 6-32 x 1/2" flat | SC-2239 | 2 |
| 12 | Screw, 10-32 x 1/2, NF Phil truss m/s, 18-8 S/S | SC-2661 | 4 |
| 13 | Screw, #10 x 1/2 SMS hex head slotted | 208/240V 1PH SC-26520 | 11 |
| | Screw, #10 x 1/2 SMS hex head slotted | 208/240V 3PH SC-26520 | 12 |
| 14* | Sensor | SN-33541 | 1 |
| 15 | Safety, 340°C | TT-3750 | 1 |

*Not shown

Service

Interior Assembly - ASC-2E

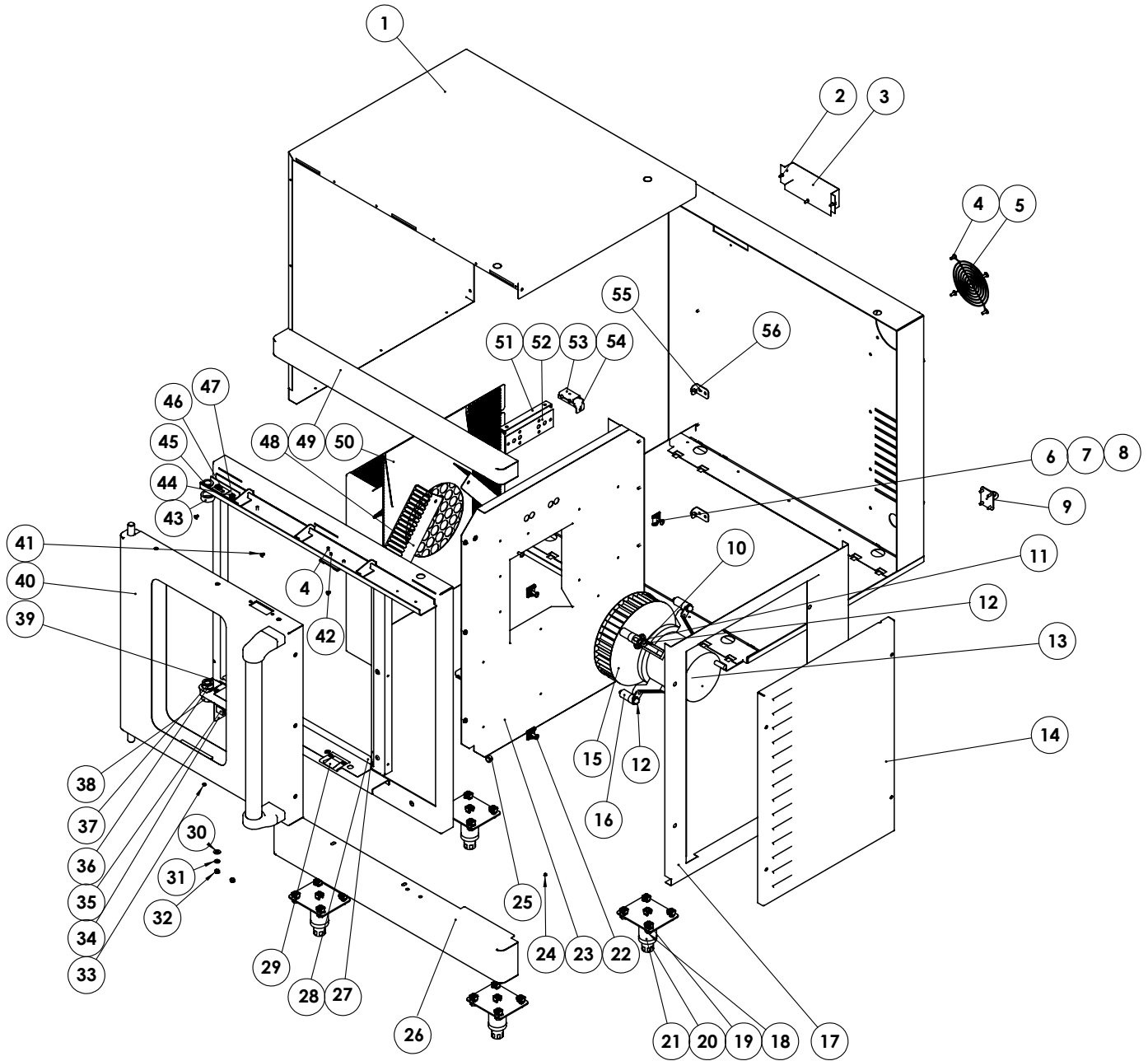

Interior Assembly - ASC-2E

| Item | Description | Part No. | Qty | Item | Description | Part No. | Qty |
|------|---|--------------------------|-----|------|---------------------------------------|--------------------------|-----|
| 1 | Body side, top | 1005455 | 1 | 29 | Door latch ASC-2 | LT-26976 | 2 |
| 2 | Screw, #10 x 1/2 SMS hex head slotted | SC-26520 | 25 | 30 | Washer, 1/4", flat, 5/8 OD 18-8 | WS-22094 | 4 |
| 3 | Vent riser, double stack | 1005465 | 1 | 31 | Lock washer 1/4" | WS-2294 | 4 |
| 4 | Screw, 10-32 x 1/2, NF Phil truss M/S, 18-8 | SC-2661 | 19 | 32 | Nut, 1/4-20 nylon insert 18-8 | NU-23984 | 4 |
| 5 | Fan guard | GD-2396 | 1 | 33 | Screw, set #10-32 x 0.25 lg | SC-27433 | 1 |
| 6 | Stud, CT M6 x 27mm, 1/4 turn | ST-22193 | 4 | 34 | Bracket, door switch | 1005488 | 1 |
| 7 | Springs, M6 x 48mm, safety | SD-22194 | 4 | 35 | Switch, door | SW-34164 | 1 |
| 8 | Washers, safety, steel | WS-22195 | 4 | 36 | Spacer, door | SP-26442 | 1 |
| 9 | Bracket, tether | BT-26884 | 1 | 37 | Spacer, door | 1005449 | 1 |
| 10 | Screw, 5/16-18 x 2" hex head | SC-22423 | 4 | 38 | Hinge, door cam switch | HG-27334 | 1 |
| 11 | Washer, 5/16" split lock | WS-2867 | 4 | 39 | Cover, bearing | 1006397 | 1 |
| 12 | Washer, 5/16" flat | WS-23725 | 4 | 40 | Door assembly | DR-27848 | 1 |
| 13 | Motor, 1/4HP, 1725/1140RPM | MO-34208 | 1 | 41 | Screw, 10-32 U/C FHMS, 18-8, PH | SC-25004 | 4 |
| 14 | Door panel, louver, RH | 1006602 | 1 | 42 | Screw, #10 x 1/2 SMS hex head slotted | SC-23670 | 25 |
| 15 | Wheel, blower | WH-26895 | 1 | 43 | Spacer | SP-27997 | 1 |
| 16 | Spacer, motor | SP-26975 | 4 | 44 | Hinge, plate top universal | 1005423 | 2 |
| 17 | Panel, side, RH | 1005463 | 1 | 45 | Bushing, 0.63 x 0.63 | BU-26433 | 2 |
| 18 | Screw, 5/16-18 x 5/8 serr. hex head | SC-2351 | 16 | 46 | Plate, bushing | 1006092 | 1 |
| 19 | Nut, 5/16-18 clip | NU-26836 | 21 | 47 | Screw, 1/4-20 FHSC x 0.75 | SC-26587 | 4 |
| 20 | Foot, insert adjustment | FE-26125 | 4 | 48 | Diffuser, air | 1006396 | 2 |
| 21 | Leg | LG-26123 | 4 | 49 | Cover, top | 1005459 | 1 |
| 22 | Clip, holding, M6 | CL-22196 | 4 | 50 | Baffle assembly | 5005074 | 1 |
| 23 | Cover, insulation | 1005461 | 1 | 51 | Bracket, thermostat | 1005478 | 1 |
| 24 | Rivet, #42 stainless | RI-2097 | 8 | 52 | Cover, element | 1005460 | 1 |
| 25 | Bushing, 1/2" hole | BU-3006 | 1 | 53 | Retainer, element | 1005477 | 4 |
| 26 | Cover, bottom | 1005458 | 1 | 54 | Bracket, MTG element | 1005349 | 4 |
| 27 | Gasket, oven L/R | 1005311 | 2 | 55 | Bracket, MTG baffle | 1005310 | 2 |
| 28 | Gasket, oven top/bottom | 1005316 | 2 | 56 | Stud, shoulder, short | ST-2546 | 3 |

Service

Full Assembly - ASC-4E

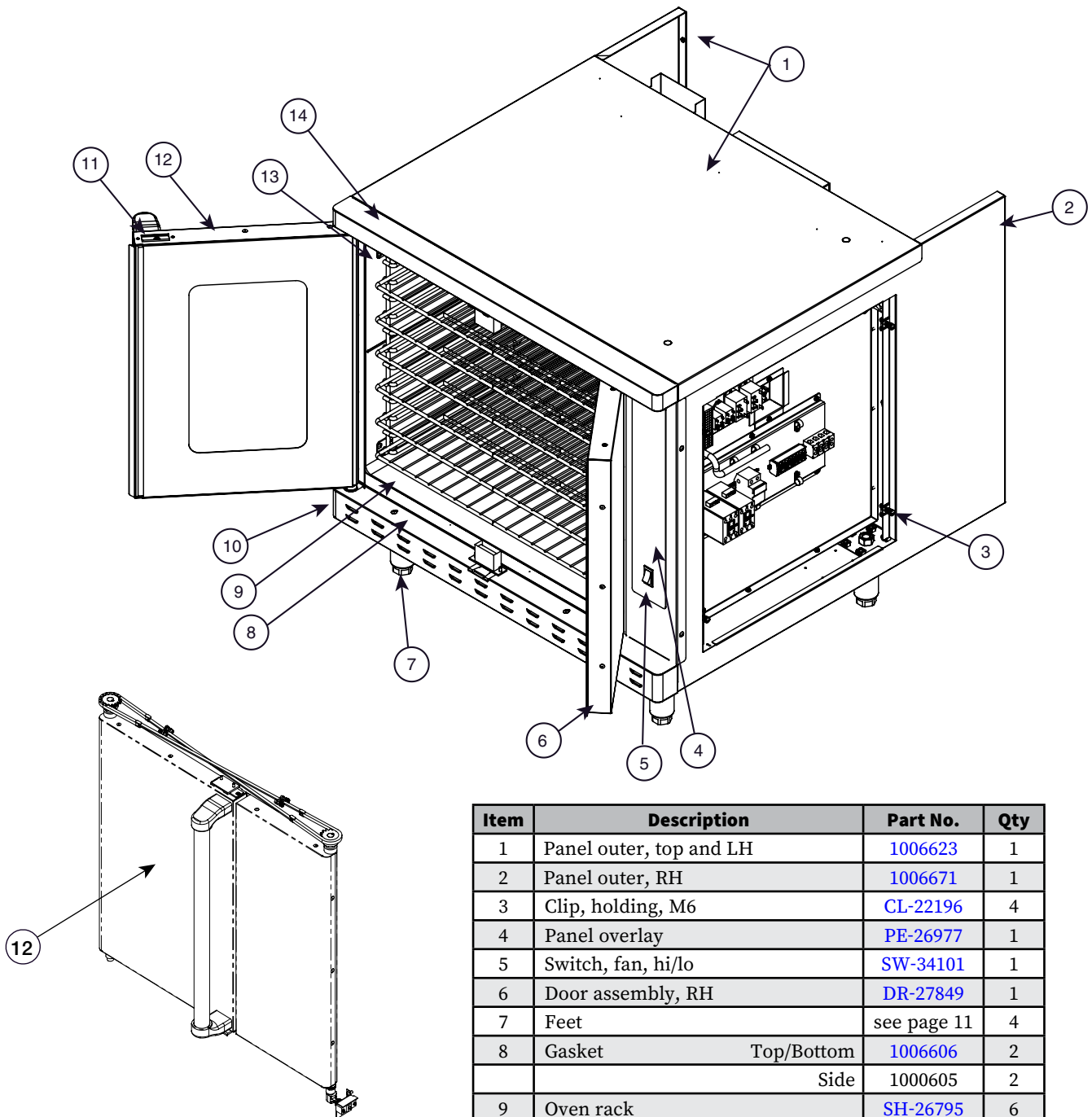

| Item | Description | Part No. | Qty | |
|------|--------------------------|--------------------------|-------------------------|---|
| 1 | Panel outer, top and LH | 1006623 | 1 | |
| 2 | Panel outer, RH | 1006671 | 1 | |
| 3 | Clip, holding, M6 | CL-22196 | 4 | |
| 4 | Panel overlay | PE-26977 | 1 | |
| 5 | Switch, fan, hi/lo | SW-34101 | 1 | |
| 6 | Door assembly, RH | DR-27849 | 1 | |
| 7 | Feet | see page 11 | 4 | |
| 8 | Gasket | Top/Bottom | 1006606 | 2 |
| | | Side | 1000605 | 2 |
| 9 | Oven rack | SH-26795 | 6 | |
| 10 | Cover, bottom hinge | 1006678 | 1 | |
| 11 | Latch | LT-26976 | 2 | |
| 12 | Door assembly, LH window | DR-27850 | 1 | |
| | Door assembly, LH solid | DR-36068 | 1 | |
| 13 | Side rack | SR-26396 | 2 | |
| 14 | Cover, top hinge | 1006679 | 1 | |
| 15* | Panel, louvered access | 1006672 | 1 | |
| 16* | Cord | CD-34094 | 1 | |

*Not shown

Control Assembly - ASC-4E

208V, 240V

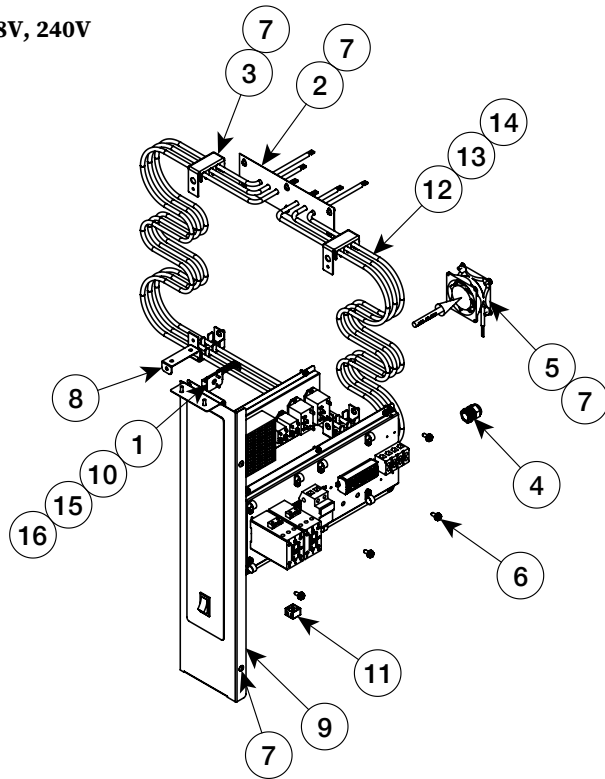

440V, 480V

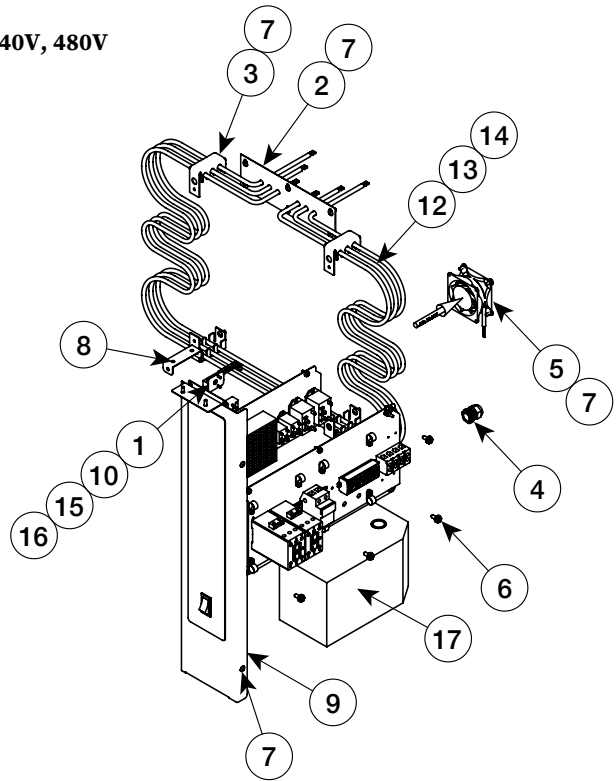

| Item | Description | Part No. | Qty |
|------|---|---------------|-----|
| 1 | Guard sensor | 1493 | 1 |
| 2 | Element patch, electric | 1004607 | 1 |
| 3 | Element & baffle bracket | 1011446 | 4 |
| 4 | Bushing, straight, strain relief | Bu-3964 | 1 |
| 5 | Fan, box, 230v, 34CFM | FA-3974 | 1 |
| 6 | Screw, #10 x 1/2 SMS hex head slotted | Sc-26520 | 10 |
| 7 | Screw, 10-32 x 1/2, NF Phil truss M/S, 18-8 S/S | Sc-2661 | 18 |
| 8 | Holder, probe core | 1006611 | 1 |
| 9 | Control assembly, electronic | 5011251 | 1 |
| 10 | Block, sensor mounting | BK-24427 | 1 |
| 11 | Block, 2 terminal, porcelain | BK-33546 | 1 |
| 12 | Element, rear | 240V EL-34125 | 1 |
| | Element, rear | 208V EL-34128 | 1 |
| | Element, rear | 480V EL-34345 | 1 |
| 13 | Element, front | 208V EL-34126 | 1 |
| | Element, front | 240V EL-34129 | 1 |
| | Element, front | 480V EL-34347 | 1 |
| 14 | Element, middle | 208V EL-34127 | 1 |
| | Element, middle | 240V EL-34146 | 1 |
| | Element, middle | 480V EL-34346 | 1 |
| 15 | Screw, 6-32 x 1/2, NC Phil, flat | Sc-2239 | 2 |
| 16 | Sensor | Sn-33541 | 1 |
| 17 | Transformer | 480V Tn-34421 | 1 |

Service

Interior Assembly - ASC-4E

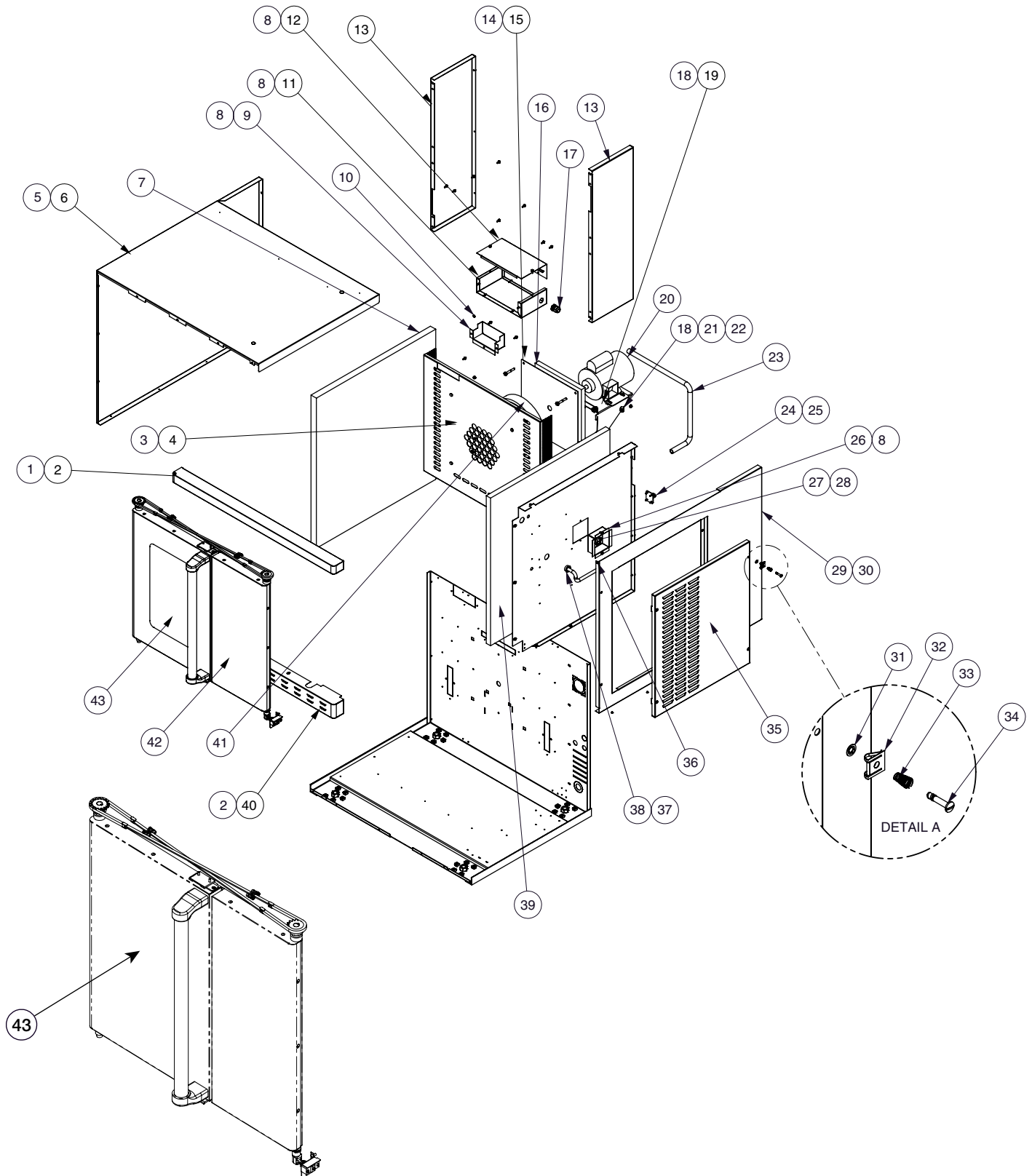

Interior Assembly - Asc-4E

| Item | Description | Part No. | Qty |
|------|---|----------|-----|
| 1 | Cover, top hinge | 1006679 | 1 |
| 2 | Screw, 10-32 x 1/2, NF Phil truss M/S, 18-8 | SC-2661 | 4 |
| 3 | Screw, 1/4-20 x 1/2" hex head | SC-22729 | 4 |
| 4 | Baffle assembly | 5005222 | 1 |
| 5 | Rivet, blind, #44, stainless | RI-2100 | 7 |
| 6 | Body, side / top | 1006623 | 1 |
| 7 | Insulation, 1-1/2" thick 28" x 30.5" | IN-27867 | 1 |
| 8 | Screw, #10 x 1/2 SMS hex head slotted | SC-26520 | 40 |
| 9 | Moisture vent cover | 1004599 | 1 |
| 10 | Nut, 10-32, NF hex MS, #18-8 | NU-2215 | 6 |
| 11 | Element box bottom | 1004612 | 1 |
| 12 | Element box top | 1004606 | 1 |
| 13 | Bracket, back stiffener | 1007068 | 2 |
| 14 | Screw, 5/16-18 x 2" hex head | SC-22423 | 4 |
| 15 | Motor cavity plate | 1011111 | 1 |
| 16 | Insulation, 1" thick 10.875" x 10.875" | IN-27866 | 1 |
| 17 | Bushing, straight, strain relief | BU-34606 | 2 |
| 18 | Screw, 5/16-18 x 5/8" hex cap | SC-2900 | 6 |
| 19 | Motor mount | 1009810 | 1 |
| 20 | Convection motor | MO-34215 | 1 |
| 21 | Washer, lock, 5/16 dia. | WS-2867 | 6 |
| 22 | Nut, hex, 5/16-18 | NU-2866 | 4 |
| 23 | Tube, flexible conduit 3ft | TU-33178 | 1 |
| 24 | Bracket, tether | BT-26884 | 1 |
| 25 | Screw, 10-32 x 1/2, NF Phil, flat | SC-23670 | 4 |
| 26 | Box assembly, high limit | 5003658 | 1 |
| 27 | Switch, high limit | SW-34150 | 1 |
| 28 | Screw 10-32 x 1/4" pan head | SC-26791 | 8 |
| 29 | Panel, RH side | 1006671 | 1 |
| 30 | Rivet, #42 stainless | RI-2097 | 6 |
| 31 | Washer, safety, steel | WS-22195 | 4 |
| 32 | Clip, holding, M6 | CL-22196 | 4 |
| 33 | Spring, M6 x 48, safty | SD-22194 | 4 |
| 34 | Stud, M6 x 27mm, 1/4 turn | ST-22193 | 4 |
| 35 | Panel, access, louvered | 1006672 | 1 |
| 36 | Rivet, 5/32 dome | RI-26827 | 1 |
| 37 | Tubing, conduit 3/8" x 30" long | TU-22256 | 1 |
| 38 | Bushing, 1" hole | BU-33619 | 1 |
| 39 | Isulation 1" thick 28" x 30" | IN-27866 | 1 |
| 40 | Cover, bottom hinge | 1006678 | 1 |
| 41 | Wheel, blower electric | WH-26405 | 1 |
| 42 | Door, RH | DR-27849 | 1 |
| 43 | Door, LH window | DR-27850 | 1 |
| | Door, LH solid | DR-36068 | 1 |

*Prior to serial number 870689

Service

Door Package - ASC-4E

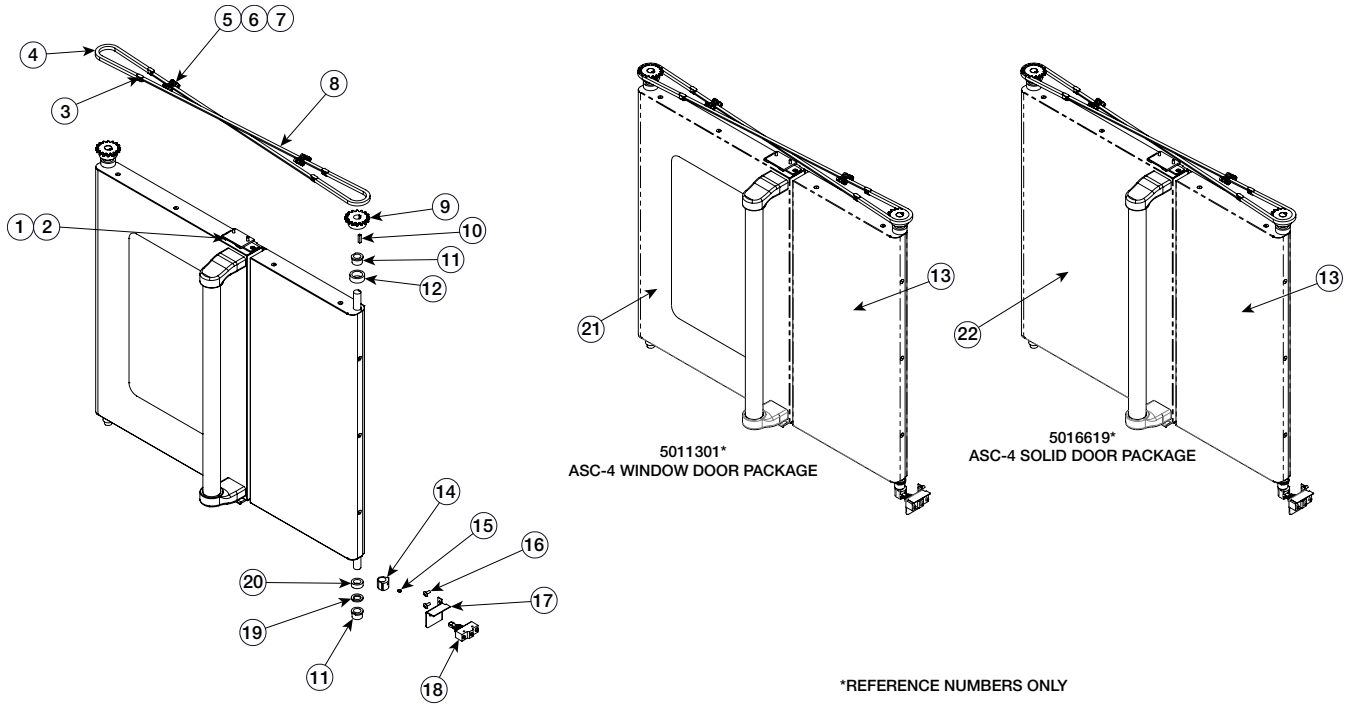

*REFERENCE NUMBERS ONLY

| Item | Description | Part No. | 5011301/Qty | 5016619/Qty |
|------|---|----------|-------------|-------------|
| 1 | Screw, 10-32 x 1/2, NF Phil, flat | SC-23670 | 8 | 8 |
| 2 | Roller latch with strike | LT-26976 | 2 | 2 |
| 3 | Chain, master link | CH-26622 | 4 | 4 |
| 4 | Chain, door drive | CH-26623 | 2 | 2 |
| 5 | Linkage assy, short | 5003667 | 2 | 2 |
| 6 | Screw, #10-32 x 0.75 SHC | SC-26704 | 4 | 4 |
| 7 | Nut, 10-32 unf hex MS, 18-8 sst | NU-2215 | 8 | 8 |
| 8 | Linkage assy, long | 5003666 | 2 | 2 |
| 9 | Sprocket, 0.625" Bore, 35 bs 16t | SO-26620 | 2 | 2 |
| 10 | Block, key sprocket | BK-26625 | 2 | 2 |
| 11 | Bushing, 0.63 x 0.63 | BU-26433 | 4 | 4 |
| 12 | Spacer | SP-27997 | 2 | 2 |
| 13 | Door assy, RH | DR-27849 | 1 | 1 |
| 14 | Hinge, door cam switch | HG-27334 | 1 | 1 |
| 15 | Screw, set #10-32 x 0.25 lg | SC-27433 | 1 | 1 |
| 16 | Screw, 10-32 x 1/2, NF Phil truss M/S, 18-8 S/S | SC-2661 | 2 | 2 |
| 17 | Bracket, door switch | 1006712 | 1 | 1 |
| 18 | Switch, door roller | SW-34164 | 1 | 1 |
| 19 | Spacer, door | 1005449 | 2 | 2 |
| 20 | Spacer, door | SP-26442 | 2 | 2 |
| 21 | Door, window LH assembly | DR-27850 | 1 | - |
| 22 | Door, solid LH assembly | DR-36068 | - | 1 |

| Part # | Description | Revision |
|---------|---------------------------|----------|
| 5011301 | ASC-4 window door package | 1 |
| 5016619 | ASC-4 solid door package | 1 |

Door Mechanism - ASC-4E

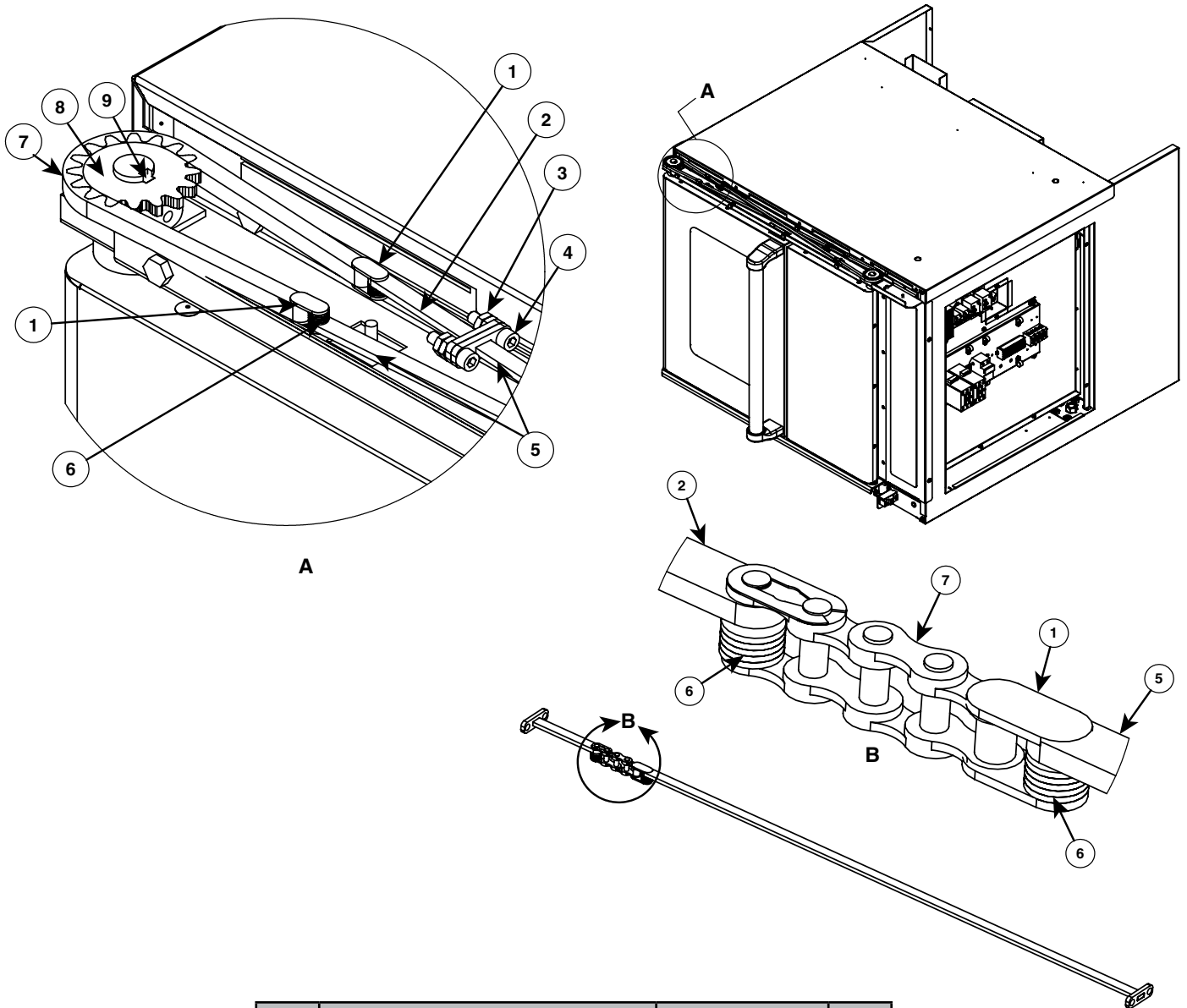

| Item | Description | Part No. | Qty |
|------|---------------------------------|--------------------------|-----|
| 1 | Chain, master link | CH-26622 | 4 |
| 2 | Linkage assembly, short | 5003667 | 2 |
| 3 | Nut, 10-32 UNF hex MS, 18-8 SST | NU-2215 | 8 |
| 4 | Screw, 10-32 x 0.75 SCH | SC-26704 | 4 |
| 5 | Linkage assembly, long | 5003666 | 2 |
| 6 | Washer, 6-32, flat, nylon | WS-23148 | 20 |
| 7 | Chain, door drive | CH-26623 | 2 |
| 8 | Sprocket, door | SO-26620 | 2 |
| 9 | Block, key sprocket | BK-26625 | 2 |

*Not shown

Service

Door Hardware - ASC-4E

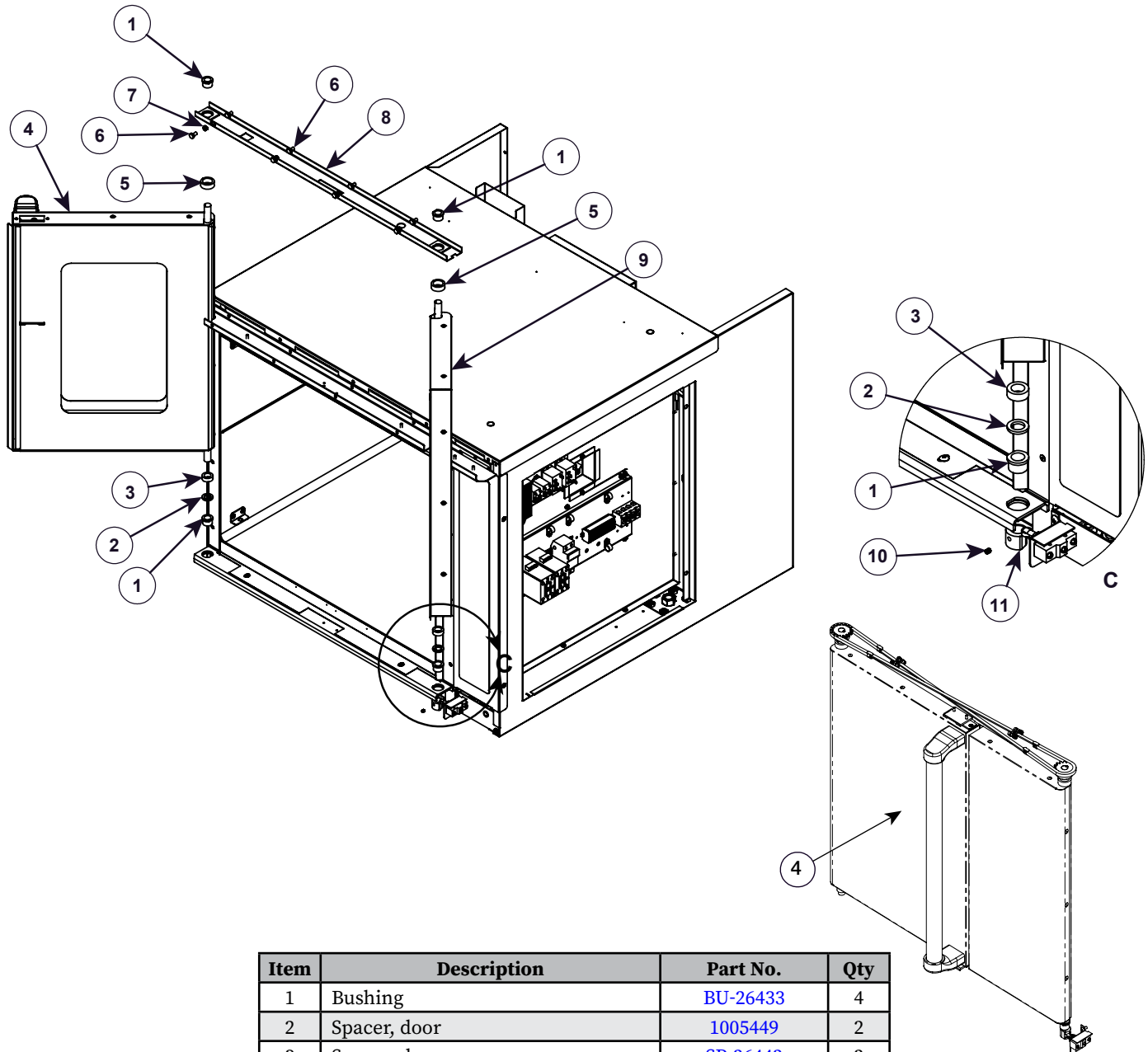

| Item | Description | Part No. | Qty |
|------|-----------------------------------|--------------------------|-----|
| 1 | Bushing | BU-26433 | 4 |
| 2 | Spacer, door | 1005449 | 2 |
| 3 | Spacer, door | SP-26442 | 2 |
| 4 | Door assembly, LH window | DR-27850 | 1 |
| | Door assembly, LH solid | DR-36068 | 1 |
| 5 | Spacer | SP-27997 | 2 |
| 6 | Screw, 1/4-20 x 1/2" hex head | SC-22729 | 8 |
| 7 | Nut, 1-4-20 nylon insert 18-8 S/S | NU-23984 | 4 |
| 8 | Top plate assembly | 5005404 | 1 |
| 9 | Door assembly, RH | DR-27849 | 1 |
| 10 | Screw, est 10-32 x 0.25 LG | SC-27433 | 1 |
| 11 | Hinge, door cam switch | HG-27334 | 1 |

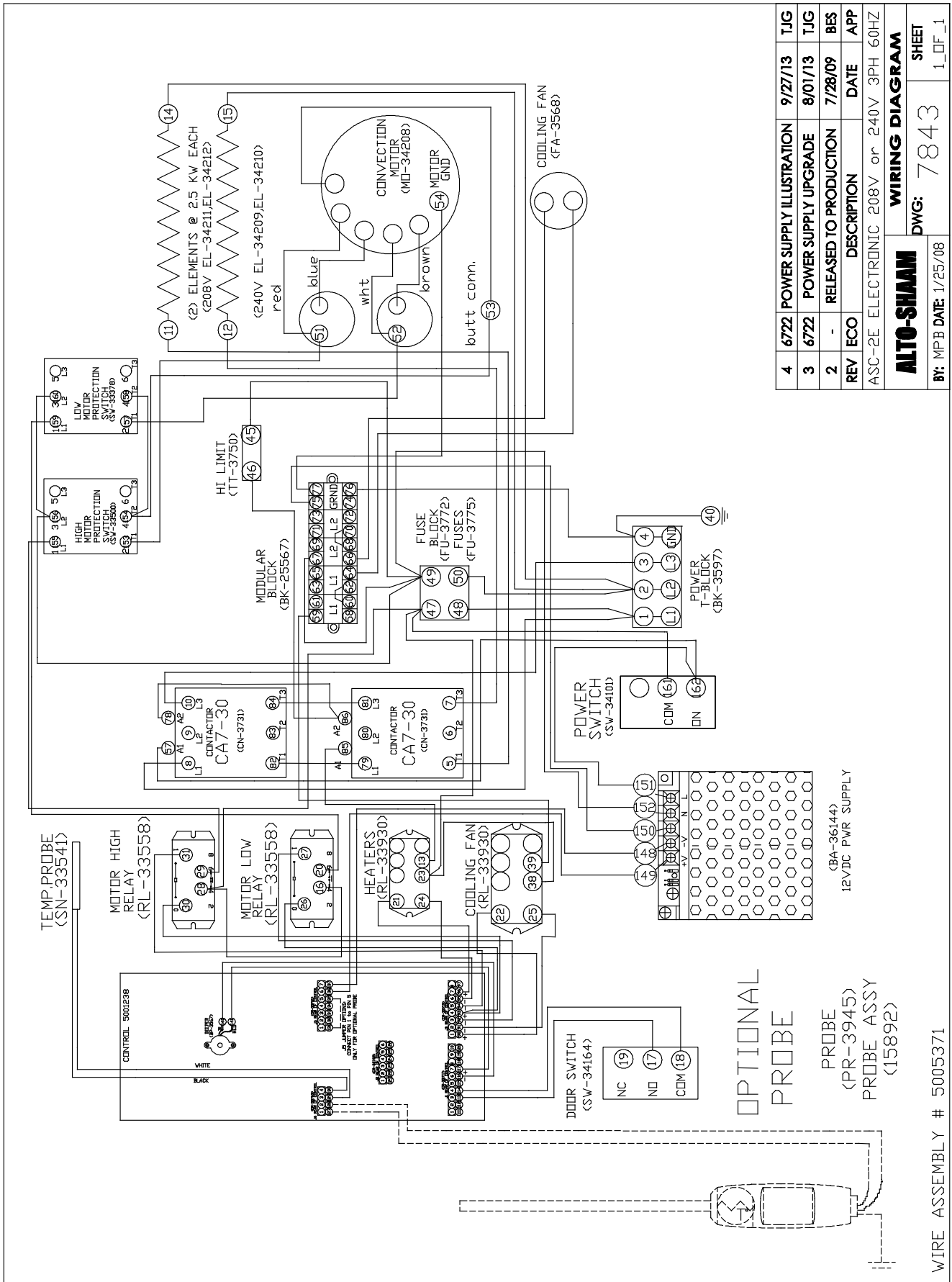

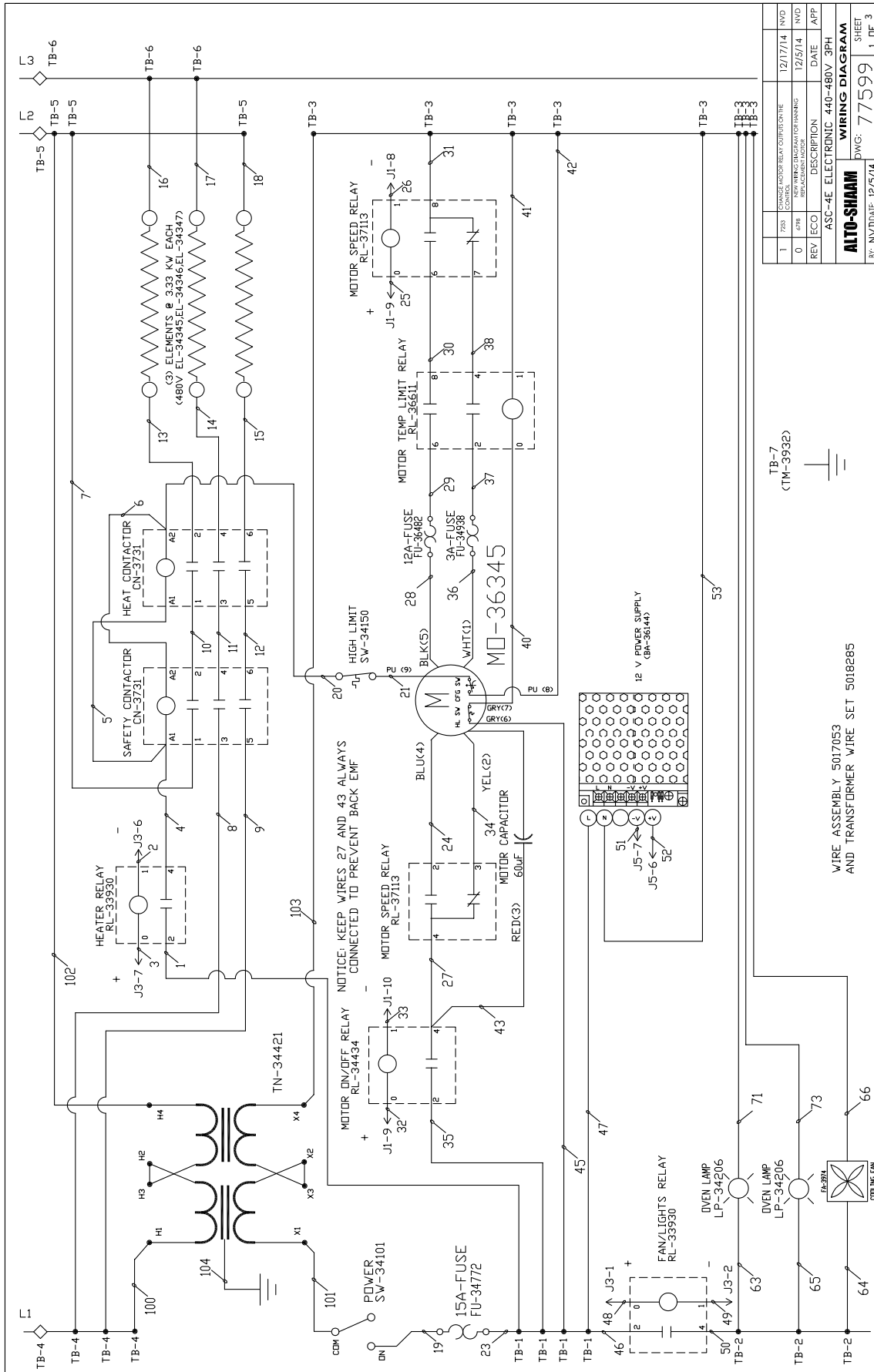

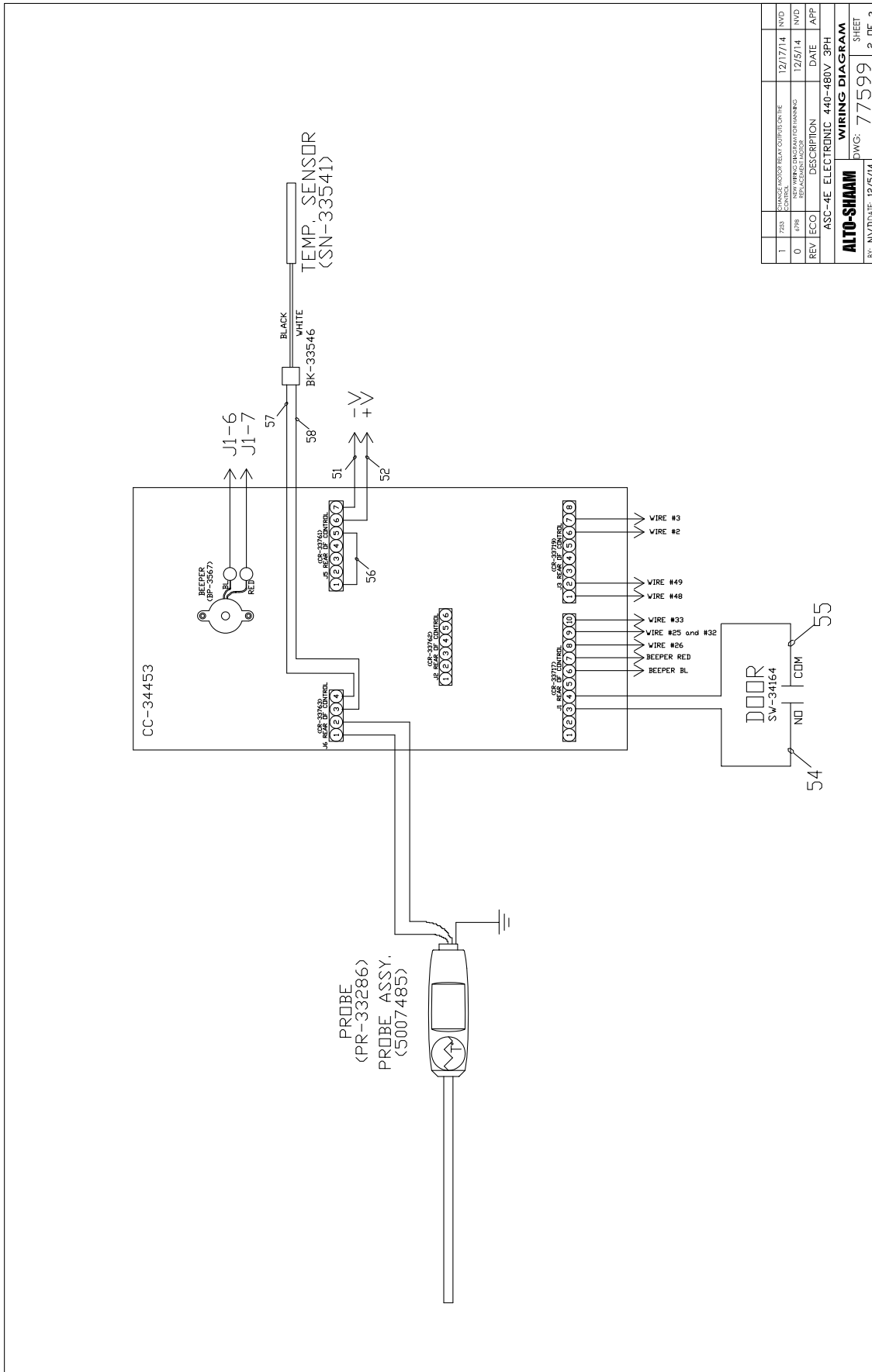

Limited Warranty

Alto-Shaam, Inc. warrants to the original purchaser only that any original part that is found to be defective in material or workmanship will, at Alto-Shaam's option, subject to provisions hereinafter stated, be replaced with a new or rebuilt part.

The original parts warranty period is as follows:

For the refrigeration compressor on Alto-Shaam Quickchillers™, five (5) years from the date of installation of appliance.

For the heating element on Halo Heat® cooking and holding ovens, as long as the original purchaser owns the oven. This excludes holding only equipment.

For all other original parts, one (1) year from the date of installation of appliance or fifteen (15) months from the shipping date, whichever occurs first.

The labor warranty period is one (1) year from the date of installation or fifteen (15) months from the shipping date, whichever occurs first.

Alto-Shaam will bear normal labor charges performed during standard business hours, excluding overtime, holiday rates or any additional fees.

To be valid, a warranty claim must be asserted during the applicable warranty period. This warranty is not transferable.

This warranty does not apply to:

1. Calibration.
2. Replacement of light bulbs, door gaskets, and/or the replacement of glass due to damage of any kind.
3. Equipment damage caused by accident, shipping, improper installation or alteration.
4. Equipment used under conditions of abuse, misuse, carelessness or abnormal conditions, including but not limited to, equipment subjected to harsh or inappropriate chemicals, including but not limited to, compounds containing chloride or quaternary salts, poor water quality, or equipment with missing or altered serial numbers.
5. Damage incurred as a direct result of poor water quality, inadequate maintenance of steam generators and/or surfaces affected by water quality. Water quality and required maintenance of steam generating equipment is the responsibility of the owner/operator.
6. Damage caused by use of any cleaning agent other than Alto-Shaam's Combitherm® Cleaner, including but not limited to damage due to chlorine or other harmful chemicals. **Use of Alto-Shaam's Combitherm® Cleaner on Combitherm® ovens is highly recommended.**
7. Any losses or damage resulting from malfunction, including loss of product, food product, revenue, or consequential or incidental damages of any kind.
8. Equipment modified in any manner from original model, substitution of parts other than factory authorized parts, removal of any parts including legs, or addition of any parts.

This warranty is exclusive and is in lieu of all other warranties, express or implied, including the implied warranties of merchantability and fitness for a particular purpose. In no event shall Alto-Shaam be liable for loss of use, loss of revenue or profit, or loss of product, or for any indirect, special, incidental, or consequential damages. No person except an officer of Alto-Shaam, Inc. is authorized to modify this warranty or to incur on behalf of Alto-Shaam any other obligation or liability in connection with Alto-Shaam equipment.

Effective November 1, 2012