

OPERATION and CARE MANUAL



Low Temperature Cooking and Holding Oven

MODELS: CH-75/DM



W164 N9221 Water Street • P.O. Box 450 • Menomonee Falls, Wisconsin 53052-0450 U.S.A.

PHONE: 262.251.3800

800.558.8744 U.S.A./CANADA

FAX: 262.251.7067 • 800.329.8744 U.S.A. ONLY

262.251.1907 INTERNATIONAL

WEBSITE:

www.alto-shaam.com

ALTO-SHAAM®

LOW TEMPERATURE COOKING AND HOLDING OVENS

UNPACKING and SET-UP

The Alto-Shaam Cooking and Holding Oven has been thoroughly tested, checked for calibration, and inspected to insure only the highest quality oven is provided. When you receive your oven, check for any possible shipping damage and report it at once to the delivering carrier.

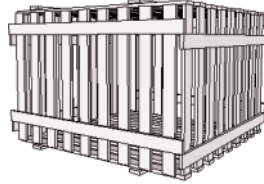

The oven, complete with unattached items and accessories, may be delivered in one or more packages. Check to insure that all the following items have been received as standard with each unit:

Drip Pan	Oven Side Racks	40 Watt Appliance Bulb
Wire Shelves	External Drip Tray	

Save all the information and instructions packed inside the oven. Complete and return the warranty card to the factory as soon as possible to insure prompt service in the event of a warranty parts and labor claim.

Optional 5" (127mm) casters or 6" (152mm) legs must be installed on the oven before use. For the best service, the oven should be installed level. The oven should NOT be installed in any area where it may be affected by steam, grease, dripping water, high temperatures or any other severely adverse conditions.

IMPORTANT: ALL CLAIMS FOR WARRANTY MUST INCLUDE THE FULL MODEL NUMBER AND SERIAL NUMBER OF THE OVEN.

ELECTRICAL INSTALLATION

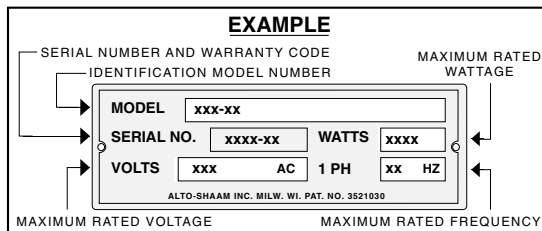

1. An oven identification tag is permanently mounted on the oven.
2. Oven models at 120/208-240 volts are dual rated units with a conversion switch mounted under an access cover on the rear of the oven, near the power cord.

With the voltage conversion switch in the 200 volt through 208 volt (**UPPER**) position, the oven will function properly with a source voltage of between 200 volts and 208 volts.

With the voltage conversion switch in the 220-240 volt (**LOWER**) position, the unit will function properly with a source voltage of between 220 volts and 240 volts.

NOTE: ALL 208-240 volts units are shipped from the factory with the voltage conversion switch in the 220-240 volt position.

Ensure that the voltage conversion switch position and the available power source match.

3. This oven must be grounded in accordance with requirements of the National Electrical Code or



ENSURE POWER SOURCE MATCHES VOLTAGE STAMPED ON OVEN IDENTIFICATION TAG

applicable local codes.

START-UP

1. Before operating the oven, clean both the interior and exterior of the unit with a damp cloth and mild soap solution. Rinse well to remove all detergent residue.
2. Clean and install the oven side racks and oven shelves. Shelves are installed with the curved edge toward the back of the oven. Insert the drip pan on the interior bottom surface of the oven.
3. Install External Drip Tray on the front of the oven. See the drawing on page 5 of this manual for mounting instructions.
4. Before operating the unit with product, become familiar with the operation of the controls. Read the following "Operation" section of this manual and operate the various control functions.



AT NO TIME SHOULD THE INSIDE OR OUTSIDE OF THE OVEN BE WASHED DOWN, FLOODED, OR CLEANED WITH WATER OR LIQUID SOLUTION. NEVER USE A BRUSH TO CLEAN. SEVERE DAMAGE OR DEATH COULD RESULT.

OVEN CONTROL PANEL

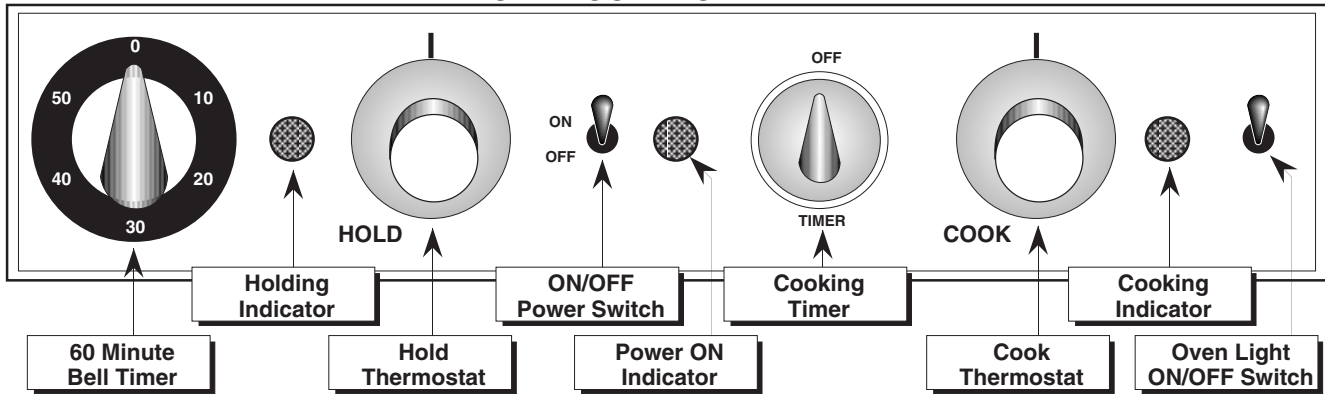

GENERAL OPERATION

1. Turn oven POWER SWITCH 'ON'.
— POWER 'ON' INDICATOR LIGHT will illuminate and will remain lit as long as the Power Switch is in the 'ON' position.
2. Set the HOLD THERMOSTAT to the required holding temperature.
— HOLDING INDICATOR LIGHT will illuminate as the Hold Thermostat calls for heat. This process will continue as long as the Power Switch and Hold Thermostat are 'ON'.
3. Set COOK THERMOSTAT to the required cooking temperature.
4. To preheat the oven, activate the Cook Thermostat by turning the COOKING TIMER clockwise.
— COOKING INDICATOR LIGHT and HOLDING INDICATOR LIGHT will illuminate as the Cook Thermostat calls for heat. This process will continue until the COOKING TIMER cycles to the 'OFF' position.

These instructions are basic operational guidelines only. For complete instructions, see the *HALO HEAT Hot Deli Guide: Recipe to Success* packed with the oven.



DISCONNECT THE CABINET FROM THE POWER SOURCE BEFORE CLEANING OR SERVICING.

EQUIPMENT CARE

Under normal circumstances, this oven should provide you with long and trouble-free service. There is no preventative maintenance required, however, the following *Equipment Care Guide* will maximize the potential life and trouble-free operation of this oven.

The cleanliness and appearance of this equipment will contribute considerably to operating efficiency and savory, appetizing food. Good equipment that is kept clean works better and lasts longer.

1. CLEAN THE OVEN DAILY.

- A. Disconnect the oven from the power source.
- B. Remove all detachable items such as wire shelves, side racks, and drip pan. Clean these items separately.
- C. Clean the interior metal surfaces of the cabinet with a damp cloth and any good alkaline or alkaline chlorinated based commercial detergent or grease solvent at the recommended strength. Use a plastic scouring pad or oven cleaner for difficult areas. Avoid the use of abrasive cleaning compounds, chloride based cleaners, or cleaners containing quaternary salts. Rinse well to remove all residue and wipe dry.
NOTE: Never use hydrochloric acid (muriatic acid) on stainless steel.
- D. To help maintain the protective film coating on polished stainless steel, clean the exterior of the cabinet with a cleaner recommended for stainless steel surfaces. Spray the cleaning agent on the cloth and wipe with the grain of the stainless steel.



Always follow appropriate state or local health (hygiene) regulations regarding all applicable cleaning and sanitation requirements for equipment.

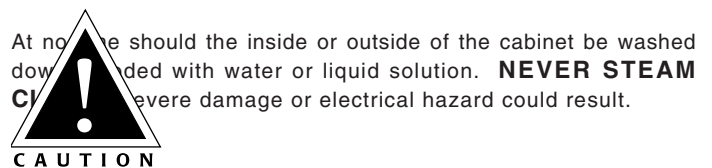

2. **DO NOT USE THE OVEN IF THE CONTROLS ARE NOT PROPERLY FUNCTIONING.**
Refer to the *Trouble Shooting Guide* located in this manual or call an authorized service technician.
3. **CHECK OVERALL CONDITION OF THE OVEN ONCE A MONTH.**
Check the oven once a month for physical damage and loose screws. Correct any problems before they begin to interfere with the operation of the oven.
4. **CHECK THE COOLING FAN IN THE OVEN CONTROL AREA.**
While the oven is warm, check that the cooling fan in the oven control area is functioning. The fan is located on the back of the unit, toward the top.

SANITATION GUIDELINES

Food flavor and aroma are usually so closely related that it is difficult, if not impossible, to separate them. There is also an important, inseparable relationship between cleanliness and food flavor. Cleanliness, top operating efficiency, and appearance of equipment contribute considerably to savory, appetizing foods. Good equipment that is kept clean, works better and lasts longer.

Most food imparts its own particular aroma and many foods also absorb existing odors. Unfortunately, during this absorption, there is no distinction between *GOOD* and *BAD* odors. The majority of objectionable flavors and odors troubling food service operations are caused by bacteria growth. Sourness, rancidity, mustiness, stale or other *OFF* flavors are usually the result of germ activity.

The easiest way to insure full, natural food flavor is through comprehensive cleanliness. This means good control of both visible soil (dirt) and invisible soil (germs). A thorough approach to sanitation will provide essential cleanliness. It will assure an attractive appearance of equipment, along with maximum efficiency and utility. More importantly, a good sanitation program provides one of the key elements in the prevention of food-borne illnesses.

A controlled holding environment for prepared foods is just one of the important factors involved in the prevention of food-borne illnesses. Temperature monitoring and control during receiving, storage, preparation, and the service of food are of equal importance.

INTERNAL FOOD PRODUCT TEMPERATURES		
HOT FOODS		
DANGER ZONE	40° TO 140°F	(4° TO 60°C)
CRITICAL ZONE	70° TO 120°F (21° TO 49°C)	
SAFE ZONE	140° TO 165°F	(60° TO 74°C)
COLD FOODS		
DANGER ZONE	ABOVE 40°F	(ABOVE 4°C)
SAFE ZONE	36°F TO 40°F	(2°C TO 4°C)
FROZEN FOODS		
DANGER ZONE	ABOVE 32°F	(ABOVE 0°C)
CRITICAL ZONE	0° TO 32°F (-18° TO 0°C)	
SAFE ZONE	0°F OR BELOW	(-18°C OR BELOW)

The most accurate method of measuring safe temperatures of both hot and cold foods is by internal product

temperature. A quality thermometer is an effective tool for this purpose and should be routinely used on all products that require holding at a specific temperature.

A comprehensive sanitation program should focus on the training of staff in basic sanitation procedures. This includes personal hygiene, proper handling of raw foods, cooking to a safe internal product temperature, and the routine monitoring of internal temperatures from receiving through service.

Most food-borne illnesses can be prevented through proper temperature control and a comprehensive program of sanitation. All these factors are important to build quality service as the foundation of customer satisfaction. Safe food handling practices to prevent food-borne illness is of critical importance to the health and safety of your customers. HACCP, an acronym for Hazard Analysis (at) Critical Control Points, is a quality control program of operating procedures to assure food integrity, quality, and safety. Taking steps necessary to augment food safety practices are both cost effective and relatively simple. While HACCP guidelines go far beyond the scope of this manual, additional information is available by contacting the USDA/FDA Food-borne Illness Education Information Center at (301)504-6803.

GENERAL HOLDING GUIDELINES

Chefs, cooks and other specialized food service personnel employ varied methods of cooking. Proper holding temperatures for a specific food product must be based on the moisture content of the product, product density, volume, and proper serving temperatures. Safe holding temperatures must also be correlated with palatability in determining the length of holding time for a specific product.

Halo Heat maintains the maximum amount of product moisture content without the addition of water, water vapor, or steam. Maintaining maximum natural product moisture preserves the natural flavor of the product and provides a more genuine taste. In addition to product moisture retention, the gentle properties of Halo Heat maintain a consistent temperature throughout the cabinet without the necessity of a heat distribution fan, thereby preventing further moisture loss due to evaporation or dehydration.

In an enclosed holding environment, too much moisture content is a condition which can be relieved. A product achieving extremely high temperatures in preparation must be allowed to decrease in temperature before being placed in a controlled holding atmosphere. If the product is not allowed to decrease in temperature, excessive condensation will form increasing the moisture content on the outside of the product.

Most Halo Heat Holding Equipment is provided with a thermostat control between 60° and 200°F (16° to 93°C). If the unit is equipped with vents, close the vents for moist holding and open the vents for crisp holding.

HOLDING TEMPERATURE RANGE		
MEAT	FAHRENHEIT	CELSIUS
BEEF ROAST — Rare	140°F	60°C
BEEF ROAST — Med/Well Done	160°F	71°C
BEEF BRISKET	160° — 175°F	71° — 79°C
CORN BEEF	160° — 175°F	71° — 79°C
PASTRAMI	160° — 175°F	71° — 79°C
PRIME RIB — Rare	140°F	60°C
STEAKS — Broiled/Fried	140° — 160°F	60° — 71°C
RIBS — Beef or Pork	160°F	71°C
VEAL	160° — 175°F	71° — 79°C
HAM	160° — 175°F	71° — 79°C
PORK	160° — 175°F	71° — 79°C
LAMB	160° — 175°F	71° — 79°C
POULTRY		
CHICKEN — Fried/Baked	160° — 175°F	71° — 79°C
DUCK	160° — 175°F	71° — 79°C
TURKEY	160° — 175°F	71° — 79°C
GENERAL	160° — 175°F	71° — 79°C
FISH/SEAFOOD		
FISH — Baked/Fried	160° — 175°F	71° — 79°C
LOBSTER	160° — 175°F	71° — 79°C
SHRIMP — Fried	160° — 175°F	71° — 79°C
BAKED GOODS		
BREADS/ROLLS	120° — 140°F	49° — 60°C
MISCELLANEOUS		
CASSEROLES	160° — 175°F	71° — 79°C
DOUGH — Proofing	80° — 100°F	27° — 38°C
EGGS — Fried	150° — 160°F	66° — 71°C
FROZEN ENTREES	160° — 175°F	71° — 79°C
HORS D'OEUVRES	160° — 180°F	71° — 82°C
PASTA	160° — 180°F	71° — 82°C
PIZZA	160° — 180°F	71° — 82°C
POTATOES	180°F	82°C
PLATED MEALS	180°F	82°C
SAUCES	140° — 200°F	60° — 93°C
SOUP	140° — 200°F	60° — 93°C
VEGETABLES	160° — 175°F	71° — 79°C

THE HOLDING TEMPERATURES LISTED ARE SUGGESTED GUIDELINES ONLY

COOKING OVEN CHARACTERISTICS

The oven is equipped with a special, high-heat-density, heating cable. Through the HALO HEAT concept, the heating cable is mounted against the walls of the cooking cavity to provide an evenly applied, thermostatically controlled, heat source. The design and operational characteristics of the oven eliminates the need for a moisture pan or a heat circulating fan. Through even heat application, the quality of a food product is maintained for many hours.

THERMOSTAT/PILOT LIGHT SEQUENCE

Whenever the thermostat is turned "ON," the pilot light will indicate the power **ON/OFF** condition of the heating cable, and consequently, the cycling of the cabinet as it maintains the dialed cavity temperature. If the pilot light does not illuminate after normal start-up, the main power source, thermostat, and/or pilot light must be checked. If the warming cabinet does not hold the temperature as dialed, the calibration of the thermostat must be checked. If the warming cabinet fails to heat or heats continuously with the thermostat "OFF," the thermostat must be initially checked for proper operation. If these items are checked and found to be in order, a continuity and resistance check of the heating cable should be made. *SEE CIRCUIT DIAGRAM.*

THERMOSTAT CALIBRATION

The thermostat is precision calibrated at the factory. Normally, no adjustment or recalibration is necessary unless the thermostat has been mishandled in transit, changed or abused while in service. A thermostat with a sensing bulb operates on hydraulic pressure, consequently, any bending of the bulb results in a change in its volume, and alters the accuracy of the thermostat calibration.

A thermostat should be checked or recalibrated by placing a quality, thermal indicator at the center of an empty holding cavity. **DO NOT CALIBRATE WITH ANY FOOD PRODUCT IN THE CABINET.** The thermostat should be set, and should be allowed to stabilize at that setting for a minimum of one hour. Following temperature stabilization, the center of the thermal swing of the air temperature within the cabinet should approximately coincide with the thermostat setting.

If calibration is necessary, the calibration screw should be adjusted with great care. The calibration screw of the thermostat is located in the thermostat dial shaft. With the shaft held stationary, a minute, clockwise motion of the calibration screw appreciably lowers the thermostat setting. A reverse, or counter-clockwise motion appreciably raises the thermostat setting. After achieving the desired cycling of the thermostat, the calibration screw must be sealed. Place a few drops of enamel sealant directly on the calibration screw.

(Red nail polish or equivalent is acceptable.)

SPECIFICATIONS

PRODUCT CAPACITY	100 lb (45 kg) maximum	
INTERIOR	18 gauge non-magnetic (non-corrosive) stainless steel — two (2) non-magnetic stainless steel side racks with shelf rungs spaced at 1-3/8" (35mm) centers — Three (3) non-magnetic stainless steel wire shelves — One (1) stainless steel drip pan — One (1) 40 watt appliance bulb	
	W x L x H: 21-7/8" x 26-1/2" x 19-3/4" (556mm x 673mm x 502mm)	
INSIDE DIMENSIONS	FULL-SIZE PANS — Ten (10) 12" x 20" x 2-1/2" — Six (6) 12" x 20" x 4" — Four (4) 12" x 20" x 6"	GASTRONORM 1/1 (530mm x 325mm x 65mm) (530mm x 325mm x 100mm) (530mm x 325mm x 150mm)
PAN CAPACITY	SHEET PANS — Up to five (5)* 18" x 26" x 1" — on wire shelves only. *Additional shelves required.	
ELECTRICAL SPECIFICATIONS	120/208-240 V.A.C. — 60 Hz, 1 ph 3000 Watts (maximum) 14.8 Amps (maximum)	NO CORD & PLUG
	220 V.A.C. — 50 Hz, 1 ph 2400 Watts 10.9 Amps	BARE END - NO PLUG
	197 lb (89 kg)	
	223 lb (101 kg)	

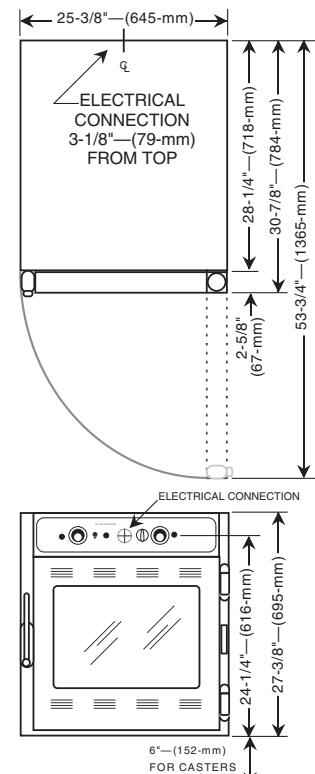

DRIP TRAY MOUNTING INSTRUCTIONS



LOW TEMPERATURE COOKING & HOLDING OVENS

MODELS:
500-TH 750-TH/II 767-SK 1000-TH-I
1000-TH-II

EXTRA LARGE DRIP PAN [Optional]

1000-TH • 1000-TH-III = A/S PN: 1115

Bottom of Extra Large Drip Pan is positioned on the bottom (lowest) side-rack position, just above the Standard Drip Pan.

STANDARD DRIP PAN*

[Bottom of oven interior • Below side-racks]

DRIP TRAY*

DRIP TRAY HOLDER*

3: 32 x 1/2" SCREWS

[A/S PN: SC-2425]

WHEN MOUNTING DRIP TRAY,
SEAL DRIP TRAY HOLDER TO
UNIT WITH AN R.T.V. SEALANT

* See individual model service manual, views
and parts lists, for Alto-Shaam part numbers.

ALTO-SHAAM®

W164 N9221 Water Street • P. O. Box 450

Menomonee Falls, Wisconsin 53052-0450

#243B • 3/88

TROUBLE SHOOTING CHECKLIST

TROUBLE	POSSIBLE CAUSE	REMEDY
Unit does not operate.	Insufficient electric power unit.	Check power source.
	Defective plug or cord.	Check and repair if necessary.
	Power switch defective.	Replace.
Cooking temperature not correct.	Cook thermostat out of calibration.	Calibrate.
Holding temperature not correct.	Hold thermostat out of calibration.	Calibrate.
Timer runs down, but oven will not go into HOLD.	Timer not de-energizing cook circuit.	Replace timer.
Cook thermostat erratic — will not hold calibration.	Cook thermostat.	Replace thermostat.
Hold thermostat erratic — will not hold calibration.	Hold thermostat.	Replace thermostat.
Oven goes from cooking temperature to cold.	Hold thermostat.	Replace hold thermostat.
Oven will not go into cook cycle when timer and cook thermostat are ON.	Timer or contactor.	<p>With timer turned ON, line voltage should appear across term. 2 and 3 of timer. If not, replace timer.</p> <p>If line voltage does appear across term. 2 and 3 of timer, it should also appear across holding coil of contactor.</p> <p>If line voltage does appear across holding coil, and it won't close its contacts, replace contactor.</p>
It takes too long to cook. (Temperature O.K.)	Heating element open, resulting in low wattage.	Replace element.
Cannot control temperature but thermostats check O.K.	Heating element grounded.	Replace element.

OPTIONS & ACCESSORIES

DESCRIPTION	ITEM	DESCRIPTION	ITEM
Bumper Guards	5221	Pocket Thermometer, °F.....	TH-3300
Carving Holders		Pocket Thermometer, °C.....	TH-3412
—Prime Rib Holder	HL-2635	Security Panel & Key Lock	14374
—Ship Round Holder	4459	Shelf, Stainless Steel	
Casters, 5" (127mm).....	4007	—Rib Rack	SH-2743
Cylinder Key Lock	LK-22567	—Wire, Flat	SH-2324
Drip Pan	1062	Stacking Hardware	4011
Legs, 6" (152mm)	5205	Thermostat, 250°F (120°C) Limit	TT-3058

SERVICE VIEW PARTS LIST: CH-75/DM

11/5/99 PART DESCRIPTION	UNIT QTY	ALTO-SHAAM PART NUMBER	PART DESCRIPTION	UNIT QTY	ALTO-SHAAM PART NUMBER
1. TOP ASSEMBLY	1	4174	22. HEATING CABLE: Length 191' (58217mm)	1	CB-3045
2. TOP ASSEMBLY MOUNTING SCREWS	5	SC-2425	23. DOOR ASSEMBLY (RIGHT-HAND) DOOR ASSEMBLY (LEFT-HAND)	1 1	5452 5471
3. TUBE TOP MOUNTING SCREWS	2	SC-2332	24. HINGE SET (1 set of 2 pairs) HINGE TO DOOR MOUNTING SCREWS (NOT SHOWN) HINGE TO UNIT MOUNTING SCREWS (NOT SHOWN)	1 6 6	HG-2014 SC-2072 SC-2073
4. TUBE BOTTOM MOUNTING SCREWS	2	SC-2425	25. DOOR HANDLE DOOR HANDLE MOUNTING SCREWS (NOT SHOWN) DOOR CATCH MOUNTING SCREWS (NOT SHOWN)	1 4 2	HD-2566 SC-2073 SC-2162
BOTTOM FILLER (NOT SHOWN)	1	1002	26. DOOR GASKET: Length 8' (2438mm)	1	GS-2398
TRIM TO BOTTOM FILLER MOUNTING SCREWS	2	SC-2425	27. SHELVES	3	SH-2324
CAPILLARY BULB GUARD (NOT SHOWN)	2	GD-2450	28. SIDE RACK	2	SR-2303
BULB GUARD MOUNTING SCREWS (NOT SHOWN)	4	SC-2425	29. DRIP PAN	1	14831
BULB MOUNTING SCREWS (NOT SHOWN)	4	SC-2077	30. BELL TIMER	1	TR-22388
BULB HOLD-DOWN (NOT SHOWN)	4	BK-2609	31. HOLD THERMOSTAT	1	TT-3057
CAPILLARY BULB (NOT SHOWN)	2	—	32. POWER SWITCH	1	SW-3528
LAMP GUARD (NOT SHOWN)	1	1056	33. PILOT LIGHT	3	LI-3025
LAMP GUARD MOUNTING SCREWS (NOT SHOWN)	2	SC-2459	34. COOK TIMER (120/208-240V) COOK TIMER (220V)	1 1	TR-3318 TR-3402
LAMP GUARD MOUNTING SCREWS (NOT SHOWN)	2	SC-2268	35. COOK THERMOSTAT	1	TT-3329
LAMP (120/208-240V)	1	LP-3480	36. LAMP SWITCH	1	SW-3041
LAMP (220V)	1	LP-3606	37. CONTACTOR	1	CN-3052
5. HOLD THERMOSTAT KNOB (FAHRENHEIT) HOLD THERMOSTAT KNOB (CELSIUS)	1 1	KN-3469 KN-3474	38. FAN FAN BLADE	2 2	FA-3342 FA-3343
6. COOK THERMOSTAT KNOB (FAHRENHEIT) COOK THERMOSTAT KNOB (CELSIUS)	1 1	KN-3468 KN-3475	39. VOLTAGE CONVERSION SWITCH	1	SW-3528
7. COOK TIMER KNOB COOK TIMER NUT	1 1	— —	40. SWITCH BOX COVER	1	11133
8. POWER SWITCH NUT	1	NU-2355	41. SWITCH BOX COVER MOUNTING SCREWS	2	SC-2459
9. BELL TIMER KNOB	1	—	42. DRIP TRAY	1	11258
10. LAMP SWITCH NUT	1	NU-2355	43. DRIP TRAY HOLDER	1	11259
11. CONTROL PANEL	1	4603	44. DRIP TRAY HOLDER SCREWS	3	SC-2425
12. CONTROL PANEL MOUNTING SCREWS CONTROL PANEL MOUNTING SCREWS	1 5	SC-2459 SC-2425	High Temperature Cable Kit #4881 (208-240V)		
13. CABLE COVER	2	1324	<u>Item</u>	<u>Description</u>	<u>Quantity</u>
14. CABLE COVER MOUNTING SCREWS	4	SC-2425	CB-3045	Cable Heating Elements	200 feet
15. TUBE ASSEMBLY	1	5450	CR-3226	Ring Connector	6
16. CASING ASSEMBLY	1	4601	IN-3488	Insulation Corner	8 feet
17. INSULATION TUBE ASSEMBLY (LEFT-HAND)	1	4170	BU-3105	Shoulder Bushing	6
18. INSULATION TUBE (RIGHT-HAND)	1	1163	BU-3106	Cup Bushing	6
19. INSULATION TUBE MOUNTING SCREWS	6	SC-2059	SL-3063	Insulating Sleeve	6
20. INSULATION: Size 25" x 120" (635-mm x 3048-mm)	1	IN-2381	TA-3540	High Temperature Tape	30 feet
21. CABLE CONNECTION HARDWARE:			Note: Cables are creme or white cloth material.		
— SHOULDER BUSHING	6	BU-3105			
— CUP BUSHING	6	BU-3106			
— HEX NUT	36	NU-2215			
— RING CONNECTOR	6	CR-3226			
— STUD	6	ST-2439			

CH-75/DM

SERVICE VIEW

1/16"=1"

9-4-90

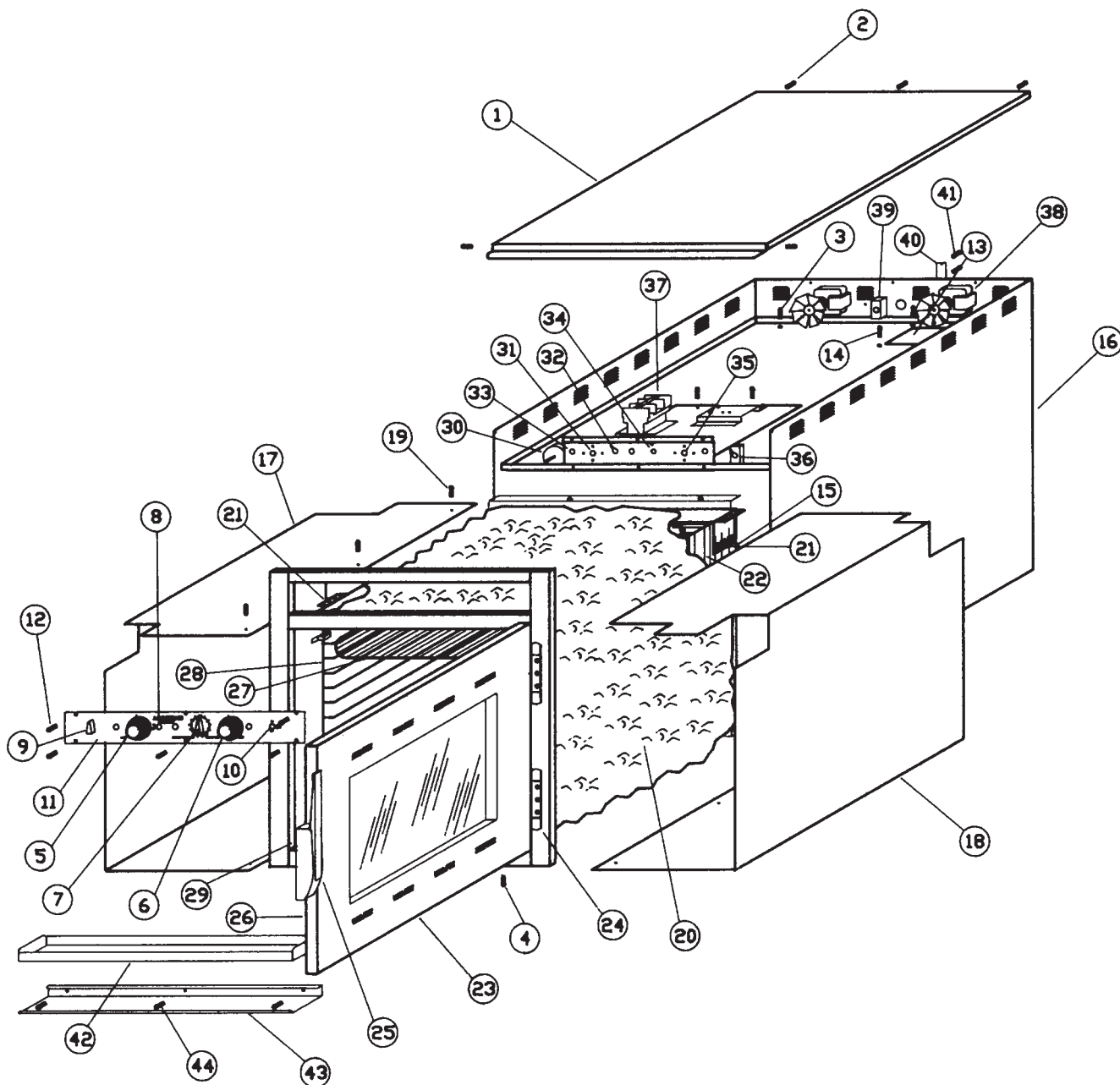

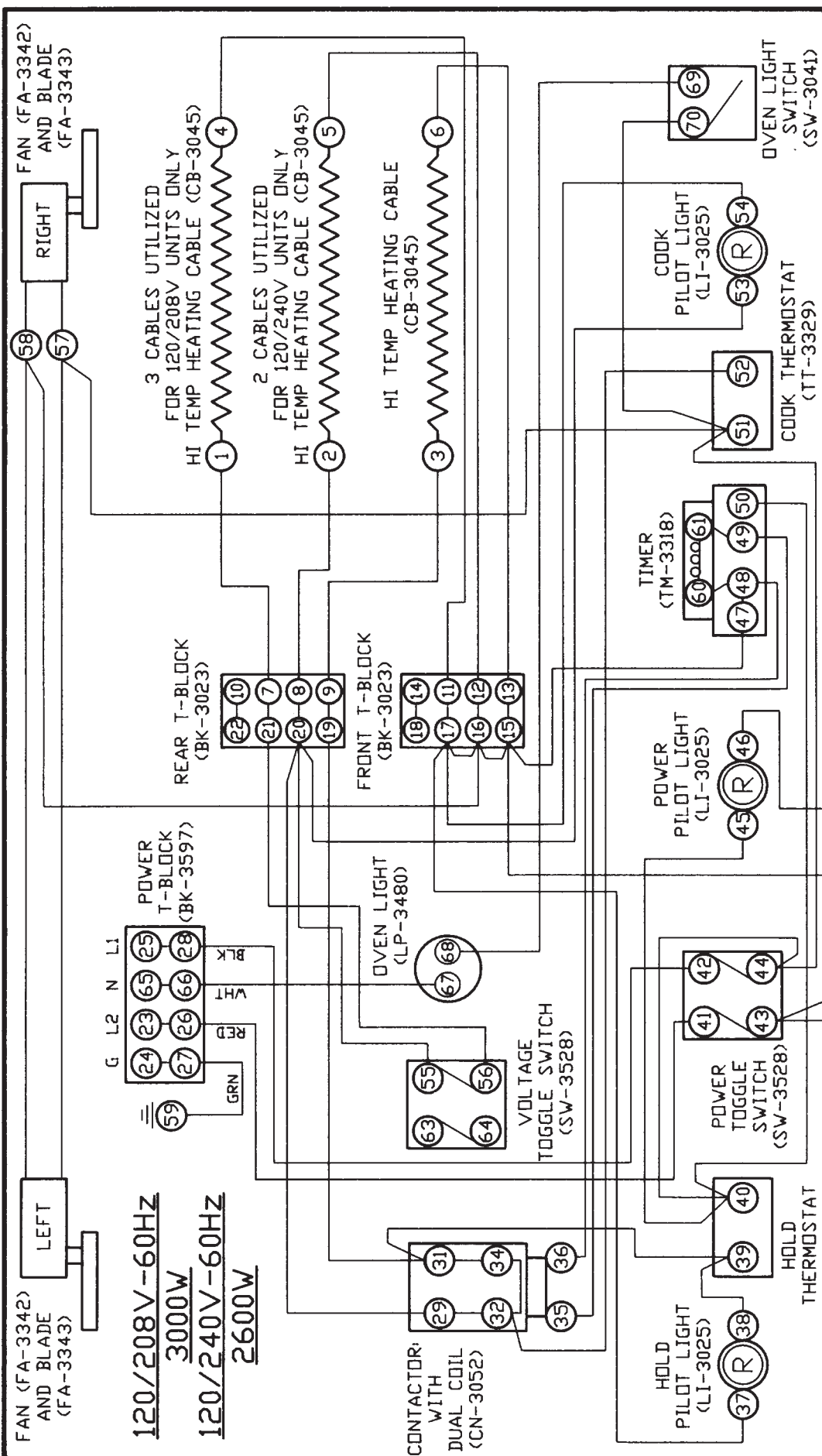

REVISIONS		CH-75,100-1/DM (120/208-240V)	
NO.	DATE	BY	
1	10-20-83	ALD	
2	12-9-86	ALD	
3	9-12-89	ALD	
4			
5			

WIRING DIAGRAM

ALTO-SHAAM INC.
MENDONNEE FALLS, WISCONSIN

DRAWN BY ALD SCALE 1"=1" DWG. NO. A-7257
APP'D *ALD* DATE 4-4-89

NOTE 1: ALL NUMBERS IN () = ALTO-SHAAM PART No's
NOTE 2: SEE DRW.#B-8061,B-8521 FOR CH-100-1/DM WIRE ASSB'S
NOTE 3: SEE DRW.#B-8062,B-8521 FOR CH-75/DM WIRE ASSB'S

TRANSPORTATION

DAMAGE and CLAIMS

ALTO-SHAAM®



All Alto-Shaam equipment is sold F.O.B. shipping point, and when accepted by the carrier, such shipments become the property of the consignee.

Should damage occur in shipment, it is a matter between the carrier and the consignee. In such cases, the carrier is assumed to be responsible for the safe delivery of the merchandise, unless negligence can be established on the part of the shipper.

1. Make an immediate inspection while the equipment is still in the truck or immediately after it is moved to the receiving area. Do not wait until after the material is moved to a storage area.
2. Do not sign a delivery receipt or a freight bill until you have made a proper count and inspection of all merchandise received.
3. Note all damage to packages directly on the carrier's delivery receipt.
4. Make certain the driver signs this receipt. If he refuses to sign, make a notation of this refusal on the receipt.
5. If the driver refuses to allow inspection, write the following on the delivery receipt:
Driver refuses to allow inspection of containers for visible damage.
6. Telephone the carrier's office immediately upon finding damage, and request an inspection. Mail a written confirmation of the time, date, and the person called.
7. Save any packages and packing material for further inspection by the carrier.
8. Promptly file a written claim with the carrier and attach *copies* of all supporting paperwork.

We will continue our policy of assisting our customers in collecting claims which have been properly filed and actively pursued. We cannot, however, file any damage claims for you, assume the responsibility of any claims, or accept deductions in payment for

ALTO-SHAAM®

W164 N9221 Water Street • P.O. Box 450 • Menomonee Falls, Wisconsin 53052-0450 • U.S.A.

PHONE: 262.251.3800

FAX: 262.251.7067 • 800.329.8744 U.S.A./CANADA

WEBSITE:

800.558.8744 U.S.A./CANADA

262.251.1907 INTERNATIONAL

www.alto-shaam.com

PRINTED IN U.S.A.