

ALTO-SHAAM®

**Combitherm®
Combination
Oven / Steamer**



Shown with ExpressTouch control
and optional hand sprayer

CT EXPRESS™

4•10ESi

4•10ESiVH

4•10CCi

CTX4-10E

CTX4-10EC

CTX4-10EVH

• TECHNICAL



W164 N9221 Water Street • P.O. Box 450
Menomonee Falls, Wisconsin 53052-0450 U.S.A.

PHONE: 262.251.3800 • 800.558.8744 U.S.A. / CANADA
FAX: 262.251.7067 • 800.329.8744 U.S.A. ONLY
www.alto-shaam.com



Consult instructions
for operation and use.



How to Use this Technical Service Manual

This manual has been compiled as a complete resource for a technician working on CT Express models. It includes necessary product information and drawings, along with helpful troubleshooting procedures.

Introduction gives a quick overview of the CT Express to aid in model identification.

Sections A through E contain information applying to all CT Express models:

- **CONTROL PANEL IDENTIFICATION** includes information on using the controllers and operating instructions. It is the same material supplied to the customer.
- **PREVENTIVE MAINTENANCE** includes procedures for cleaning with our without the CombiClean option. This information is also supplied to the customer.
- **SERVICE MODE AND ERROR CODES** explains the special programming available to you as a technician to view status, make adjustments and test functions on models equipped with Simple and Express Touch Controllers. Information is also included on the use of displayed error codes to resolve problems and on the functions that can be operated under fault conditions.
- **TROUBLESHOOTING TREES** are provided for the most common conditions you will be required to address.
- **COMBITHERM PARTS** has drawings and lists of available parts that are common to all electric models.

Sections F contains Wiring Diagrams that is specific to each model.

Navigation

Starting with the Main Table of Contents on the following page, you may click on any item that has a page number and quickly jump to the information you need. Note that you may Return to the Main Table of Contents from the bottom of any Section Contents page.

Printing

You may print the Current Page or any range of pages. Here's a tip: Because printers vary in their capacity to handle large drawings, make a test print of one of the Wiring Diagrams before printing the model's section.

TABLE OF CONTENTS

How to Use this Technical Service Manual.....	i
Introduction	iii
Control Panel Identification	A-1
Preventive Maintenance	B-1
Service Mode and Error Codes.....	C-1
Troubleshooting Trees	D-1
Combitherm Parts	E-1
Wire Diagrams	F-1

INTRODUCTION

MODEL NUMBERS

This manual covers the following CT Express models:

- 4.10esi
- 4.10esiVH
- 4.10CCi
- CTX4-10E
- CTX4-10EC
- CTX4-10EVH

FEATURES AND OPTIONS

Available on all models:

- Panel color choices
- Left-hand door
- Hand sprayer
- Single-point product temperature probe
- CombiClean® Tablet based cleaning system
- Stacking capabilities

Available only on ExpressTouch Control models:

- Smoker Mode
- Delta-T and Cook & Hold functionality
- HACCP data access
- Gold-n-Brown™ Feature
- Broiler element (not available on 1ph units)
- Catalytic Converter (CTX4-10EC only)

EXPRESSTOUCH OPERATING INSTRUCTIONS

ExpressTouch Control Operation

Start Up Procedures	A-2
Settings Screen	A-3
Upload/Download Screen	A-4
Cooking Mode Screen	A-5
Cooking Mode Screen Identification	A-6
Auxiliary Functions	A-7
HACCP Access.	A-8
Operation.	A-9

Simple Control Operation

Screen Identification	A-11
Operation.	A-12
Return to Main Table of Contents	ii

EXPRESSTOUCH OPERATING INSTRUCTIONS

START-UP PROCEDURES



When the oven is powered on, the ExpressTouch screen illuminates. "Loading" indicates that the software is booting up. The screen will also indicate what level of progress has been made as the software becomes fully operational.

MAIN MENU SCREEN

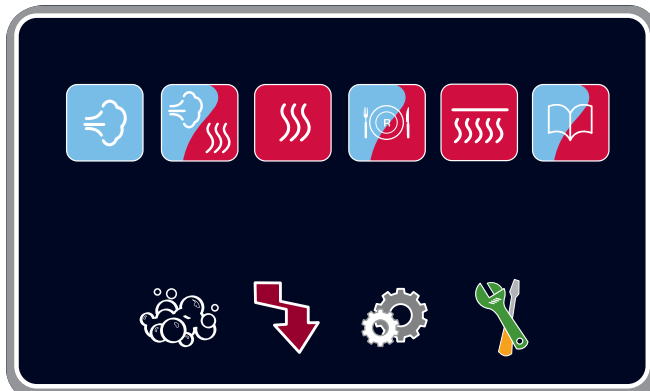

Cleaning Mode (optional)

Four (4) cleaning levels are available: rinse, light, normal, and heavy-duty cleaning.



Download/Upload Files and HACCP Access (optional)

Download all preprogrammed recipes (factory default and user-programmed) and HACCP data to a USB memory stick.



Settings

Change factory default settings. *See next page for more information.*





Service Mode (password protected)

This mode is only available to qualified service technicians.

EXPRESSTOUCH OPERATING INSTRUCTIONS

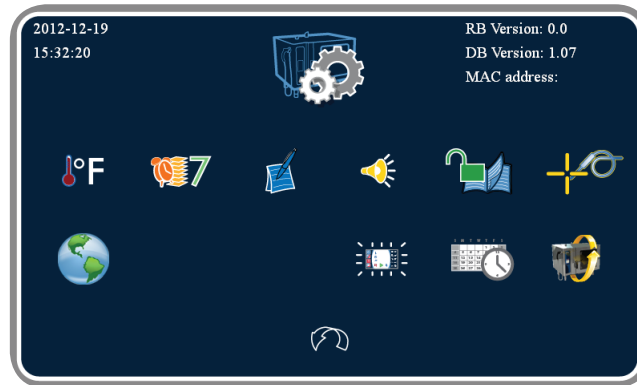
SETTINGS SCREEN



 **Fahrenheit or Celsius Function** - Choose temperature format.
Note: After choosing your format, return to the Main Menu screen and then Press Oven Power switch off.

 **Language Choice** - English, Spanish, Mandarin, French, German, Korean and Russian are available.

 **Multi-shelf Timer Number of Shelves** - Choose the default number of items in the oven to be used by the multi-shelf timer.

 **Default Memo** - Revert time/temperature setting to factory defaults when switching modes or keep the last user setting.

 **Sound/Alarm Settings** - Change alarm sounds and volume.

 **Touchscreen Brightness** - Adjust brightness of display screen.

 **Lock/Unlock Recipes** - Password protect preprogrammed recipes.

 **Set/Change Date & Time** - Set or change oven time and date settings.

 **Calibrate Product Probe (optional)**

 **Software update** - Upload new control software to the oven using a USB drive.

 **Return to Previous Screen** - Return to previous screen when finished adjusting settings.

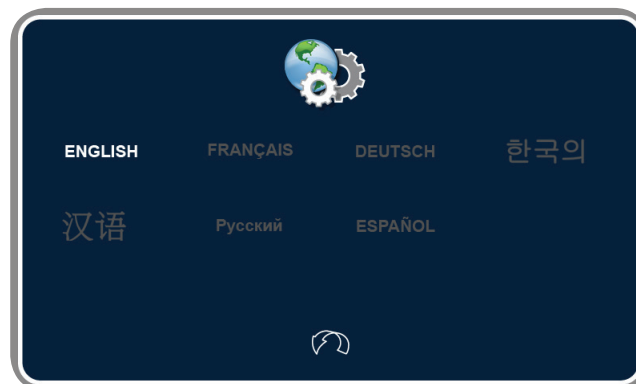

EXPRESSTOUCH OPERATING INSTRUCTIONS

UPLOAD/DOWNLOAD SCREEN

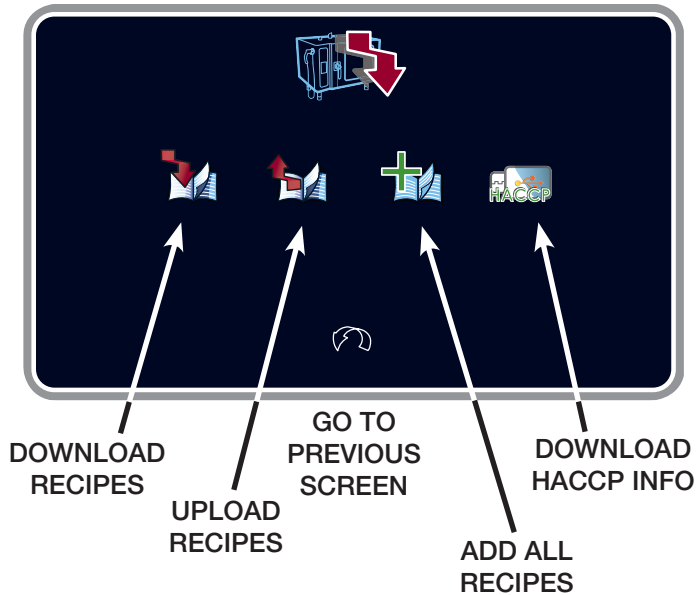

Download Recipes

Copy *all* recipes from USB memory stick to oven. This will replace and overwrite existing recipes.



Upload Recipes

Copy *all* recipes from oven control to USB memory stick.



Add All Recipes

Copy *all* recipes from USB memory stick to the oven control. This will add the recipes to the beginning of the existing recipe list.



HACCP Data (optional)

Download data to a USB drive for review in a .txt file format.

EXPRESSTOUCH OPERATING INSTRUCTIONS

COOKING MODE SCREEN

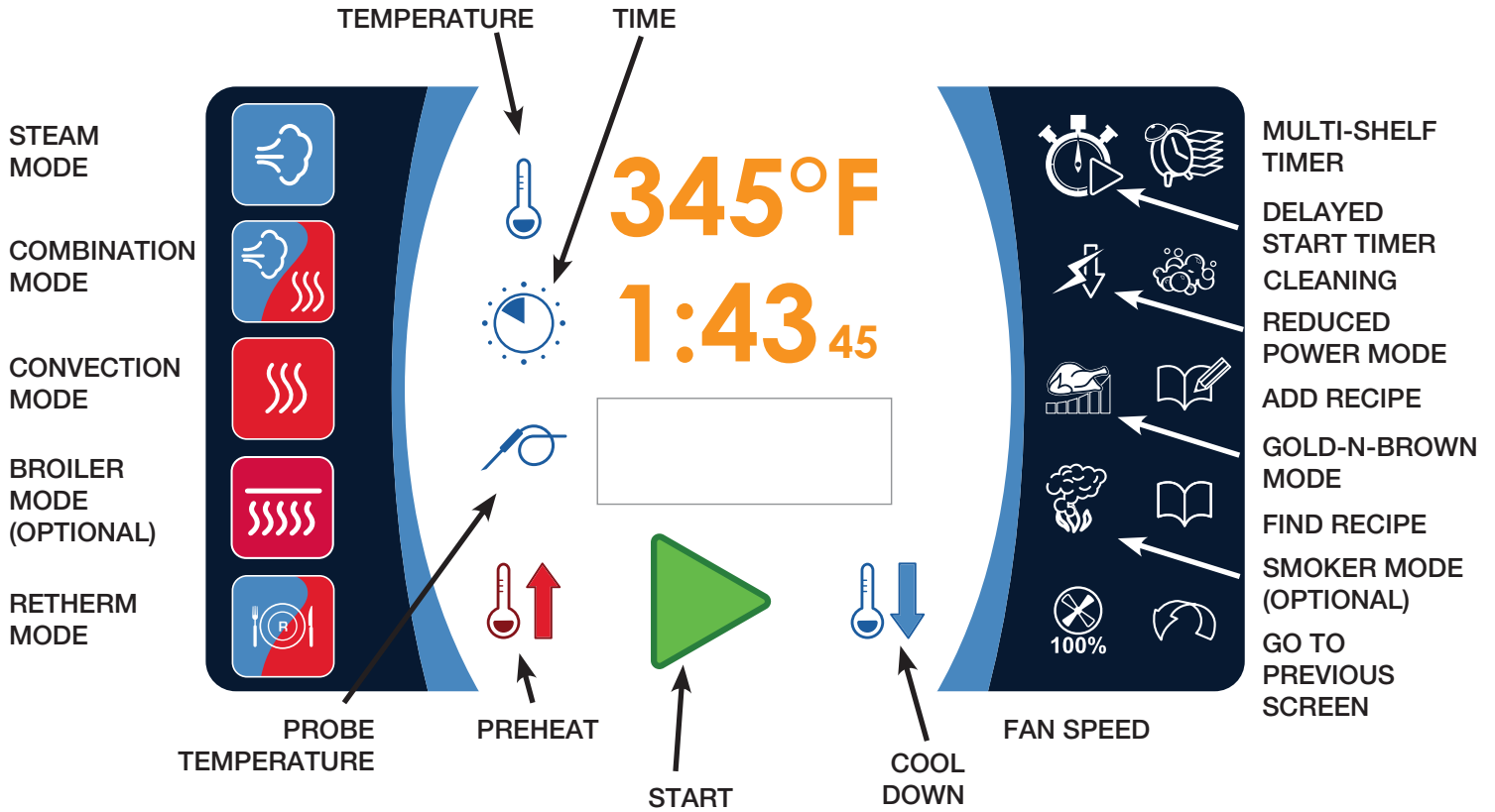

EXPRESSTOUCH OPERATING INSTRUCTIONS

COOKING MODE SCREEN IDENTIFICATION

MAIN MENU ICONS



Power ON/OFF key

Activates/deactivates power to the oven. It automatically fills the steam generator equipped models with water that will heat to a stand-by mode temperature of 188°F (77°C). **Note:** Oven will not shut down during a cooking cycle. Firmly press and hold the power key for 10 seconds to power down the oven **ONLY IF** the control has locked and is unresponsive.



Steam Mode

The oven will operate in the steam mode at a temperature range of 85°F to 250°F (30°C to 121°C).

- Automatic steaming at 212°F (100°C) factory-set default.
- Quick steaming between 213°F and 250°F (101°C and 121°C).
- Low temperature steaming between 85°F and 211°F (29°C and 99°C).



Combination Mode

Selection key for cooking with a combination of steam and convection heat. Can be set between 212°F to 485°F (100°C and 252°C).



Convection Mode

Selection key for convection cooking without steam at a temperature range of 85°F to 485°F (29°C to 252°C).



Broiler Mode (optional)

Quickly and efficiently toast or broil sandwiches, nachos, soups, and desserts with the top shelf broiling element.



Retherm Mode

Food rethermalization or reheating mode will operate with automatic steam injection at a temperature range of 245°F to 320°F (120°C to 160°C).



Temperature

Used to set the required cooking temperature, to recall the set cooking temperature, or to check the actual oven temperature.



Time

Used to set the required cooking time or recall the set cooking time.



Probe Temperature

Used to set the required internal product temperature, to recall the internal product temperature set by the operator, or to display the current internal temperature of the product.



Preheat Mode

Preheats the oven cavity to a temperature set by user.



Cool Down Mode

Lowers temperature of the oven cavity at an accelerated pace to temperature set by user.



Delayed Start Time

Quick and simple way to begin preheating your oven while you're away, and ready to go when you are.



Start/Stop

Initiates all cooking mode functions and programmed procedures stored in memory. Stops an activated cooking mode or programmed procedure currently in progress.

EXPRESSTOUCH OPERATING INSTRUCTIONS

AUXILIARY FUNCTION ICONS

Reduced Power Mode

Used to reduce kitchen power peaks and energy consumption.



Gold-N-Brown Mode

This indicator will illuminate when the browning function is set by the operator in a timed or programmed cooking cycle in any mode. Level 1 provides least amount of browning, level 6 the most.



Fan Speed

This indicator will illuminate whenever the operator sets a reduced fan speed to protect products affected by high-velocity air movement.

Return to Previous Menu

Add Recipe

Used to create, change, duplicate, and delete programmed menus.

Find Recipe

Access a menu list of all stored cooking programs.

Multi-shelf Timer

Use separate timers for one or more shelves in the oven compartment (only visible in time mode).

Steam Injection (not shown on illustration)

Press to add moisture in any cooking mode. Steam will inject into the cavity as long as the icon is touched.

 **Delta-T Core Temperature (optional) - only visible in certain modes** Cook by probe. Mode automatically adjusts cooking temperature in proportion to the internal temperature of the product.

 **Smoking Mode (optional) - only visible in convection mode or combination mode.** This indicator will illuminate when the smoking function is set by the operator in a timer, probe or programmed cooking cycle.

EXPRESSTOUCH FACTORY DEFAULT SETTINGS

COOKING MODE	OVEN TEMPERATURE	CORE TEMPERATURE	COOKING TIME
Steam	212°F (100°C)	160°F (70°C)	25 minutes
Combination Steam	350°F (175°C)	160°F (70°C)	70 minutes
Convection	350°F (175°C)	160°F (70°C)	30 minutes
Broiler/Finishing (optional)	---- °F	N/A	--- : ---
Retherm (available on ExpressTouch only)	275°F (135°C)	160°F (70°C)	5 minutes

EXPRESSTOUCH OPERATING INSTRUCTIONS

HACCP ACCESS

The ExpressTouch Combitherm meets the requirements of established HACCP criteria by providing automated sampling, record keeping, set-point validation, recipe used, dates and time. Data is captured when Core Temperature Probe cooking method is chosen. This information can be downloaded to a USB drive and then copied to your computer. The file format is text (.txt).

NOTICE: You can access this information from the Upload/Download Screen. See illustrations on page A-4 for navigation.

CAUTION: The CombiOven USB port is not recommended for use with personal hand held devices.

1. To download the data collected, remove the cap of a USB port located on the side of the oven and insert the USB flash drive. If the flash drive is not recognized by the Combitherm, a question mark will appear on screen. Try again with another flash drive device or call Alto-Shaam Service.



2. **HACCP** PRESS TO DOWNLOAD INFORMATION.



3. WAIT FOR THE ICON TO CHANGE FROM LOADING TO COMPLETE.



4. **✓** PRESS TO CONFIRM TRANSFER.
5. Remove the USB flash drive and replace the cap on the USB port.

The download process will automatically create a folder on the USB flash drive titled "haccp". Each text file contains cooking program specifics. See illustration below.

```
HACCP
Unit:                00:30:D6:FF:28:63

Date:                2011-01-09
Program:             Steam

Start time:          22:10:31
Stop time:           22:14:37
Elapsed cook time:   00:04

Multi shelf timer:   no
Reduced energy:      no
Recipe active:       no

Temperature unit:    °F

Cavity start temperature: 191
Cavity stop temperature:  217
Cavity temperature reached: 00:02







Core start temperature:  176
Core stop temperature:   215
Core temperature reached: 00:00

Door open count:      0
```

EXPRESSTOUCH OPERATING INSTRUCTIONS

Turn on and preheat the oven

Alto-Shaam recommends preheating the Combitherm® before cooking.

- Press the **Power ON** key.  or  Green light will appear while oven is booting up.
- Choose a **Mode**.  Steam  Combi  Convection  Retherm
- Choose **Preheat**. 
- Type temperature on keypad and press **Enter**. ✓
- Oven beeps when it is preheated.





To cook with preprogrammed recipes

- Load food into oven.
- Press the **Recipes** key. 
- Locate food item program by scrolling through pages using arrow keys.
- Press preprogrammed food item icon.
- Oven begins operating automatically.

NOTICE: TO SHUT THE OVEN OFF, PRESS AND HOLD  FOR FIVE SECONDS. THE RED LIGHT WILL APPEAR INDICATING THAT THE OVEN WILL BEGIN THE SHUT DOWN PROCESS.



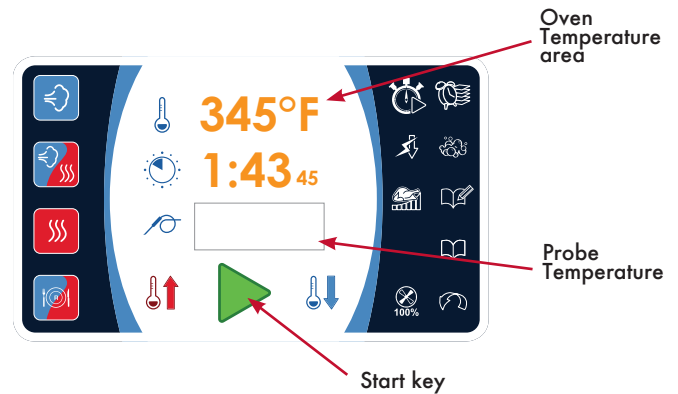

TO FORCE SHUT DOWN IN THE RARE EVENT THE CONTROL LOCKS UP, PRESS AND HOLD  FOR TEN SECONDS.

To cook manually by probe

- Choose a **Mode**.  Steam  Combi  Convection  Retherm
- Press the **Oven Temperature** area to the right of the thermometer icon, set oven temperature on the keypad, and press **Enter**. ✓
- Press the **Probe Temperature** area to the right of the probe icon, set probe temperature on the keypad, and press **Enter**. ✓
- Load food into oven and insert probe into food.
- Press the **Start** key. 



To cook manually by time

- Choose a **Mode**.  Steam  Combi  Convection  Retherm
- Press the **Oven Temperature** area to the right of the thermometer icon, set oven temperature on keypad, and press **Enter**. ✓
- Press the **Cook Time** area to the right of the timer, set cook time on keypad, and press **Enter**. ✓
- Load food into oven.
- Press the **Start** key. 

EXPRESSTOUCH OPERATING INSTRUCTIONS

To use Gold-n-Brown™

- Follow the first three steps of “To cook manually by probe” or “To cook manually by time” from the front of this sheet.

- Press the **Gold-n-Brown** key. 



- Select the desired Gold-n-Brown level and press the corresponding key.



- Press the **Start** key. 



To program a recipe

- Press the **Add a Recipe** key. 

- Follow the first three steps of “To cook manually by probe” or “To cook manually by time” from the front of this sheet for each cooking step.

- If there is more than one cooking step, press the **Write** key between each step. 

- After the last cooking step, press the **Confirm Changes** key. 

- A keypad will appear. Input the name of the recipe and press the **Confirm Changes** key. 

NOTICE: TO SHUT THE OVEN OFF, PRESS AND HOLD  FOR FIVE SECONDS. THE RED LIGHT WILL APPEAR INDICATING THAT THE OVEN WILL BEGIN THE SHUT DOWN PROCESS.

TO FORCE SHUT DOWN IN THE RARE EVENT THE CONTROL LOCKS UP, PRESS AND HOLD  FOR TEN SECONDS.

To clean the oven

- Press the **Cleaning** key. 

- Press the **Water On** key. 

- If oven is too hot to proceed, the **Oven Too Hot** warning screen will appear. Open the oven door to allow the oven to cool. When the oven is finished cooling, begin the cleaning procedure again.

- Select **Rinse, Light, Normal, or Heavy Duty** cleaning.



- For **Light, Normal, or Heavy Duty**, insert appropriate number of CombiClean® tabs as directed by the touchscreen, or spray CombiClean liquid cleaner inside the oven. Close the oven door and press the **Start** key. 
- Oven beeps when it is done cleaning. Leave door slightly ajar when cleaning is finished.

SIMPLE CONTROL OPERATING INSTRUCTIONS

CONTROL PANEL IDENTIFICATION

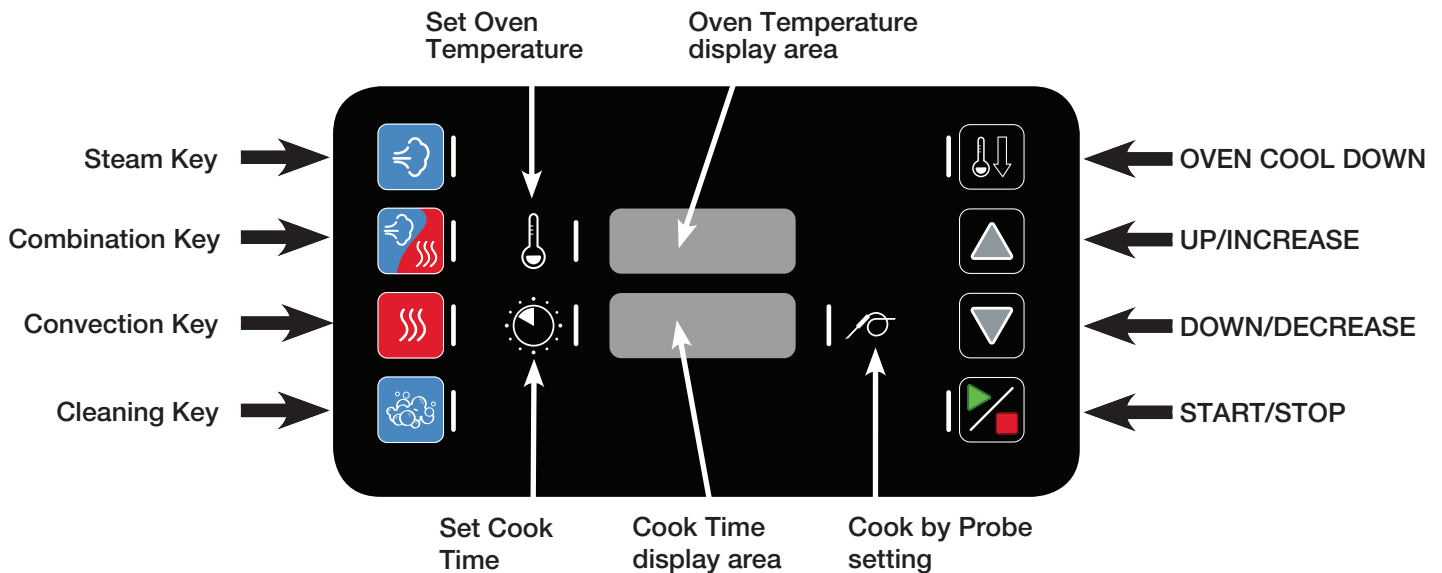

The Steam mode provides the operator with the ability to steam, poach, or blanch. This mode will automatically steam at the boiling point of water; quick-steam above the boiling point for faster cooking results; or low temperature steam, below the boiling point, for more delicate products such as pâté, mousse, seafood, or custard.

The Combination mode will prove to be the most versatile and widely used mode the Combitherm oven has to offer. It will produce the best possible results on the widest variety of products — all within the shortest period of time. The unique control function of this mode enables the operator to roast or bake with a combination of steam and convection heat. In addition to shorter cooking times, this combination of steam and heat offers less product shrinkage and more moisture retention than obtained in a standard convection oven.

The Convection mode operates with hot circulated air within a temperature range of 85° to 485°F (29 to 252°C). For many applications, better results may be achieved with the Combination mode; therefore, the operator may want to consider using the Convection mode on a more limited basis.

Oven Cool Down Process:

- Cooking process must be inactive
- Press "Cool Down" button until LED lights (LED remains ON while in Cool Down mode)
- Press "Decrease Value" or "Increase Value" to adjust cool down temperature
- Cook temperature display area is used to display cool down temperature
- Display will show last valid cool down temperature
- Cool down temperature range is 85° - 575°F (30° - 300°C)
- Press "Start/Stop" until LED lights to accept cool down temperature and initiate cool down process
- Door must be open to start cool down process; Cook time display area will display "door" if door is not open
- Cook temperature display area will display set cool down temperature
- Cook time display area will display current cool down temperature











Fahrenheit or Celsius Function - choose temperature format:

- Unit is not in a cooking or cleaning process
- Press "Set Cooking Temperature", "Decrease Value" and "Increase Value" buttons simultaneously for 1 second
- Cooking temperature display area will display last value "C" or "F"; Display will alternate between "C" and "F" every 2 seconds
- Press "Start/Stop" key when the display is showing the desired value ("C" or "F")







SIMPLE CONTROL OPERATING INSTRUCTIONS

Turn on and preheat the oven







Alto-Shaam recommends preheating the Combitherm® before cooking.

- Press the **Power** key.  or  Green light will appear while oven is booting up.
- Choose a **Mode**.  Steam  Combi  Convection
- Press **Oven Temperature** key. 
- Adjust temperature with arrow keys. 
- Press **Cook Time** key. 
- Adjust time with arrow keys. 
- Press the **Start/Stop** key. 
- Preheat oven before loading food.

To cook manually by probe

- Choose a **Mode**.  Steam  Combi  Convection
- Press the **Oven Temperature** key; adjust temperature with arrow keys.  
- Press the **Probe Temperature** key; adjust temperature using the arrow keys. 
- Load food into oven and insert probe into food.
- Press the **Start/Stop** key. 

To cook manually by time

- Choose a **Mode**.  Steam  Combi  Convection
- Press the **Oven Temperature** key; adjust temperature with arrow keys.  
- Press the **Cook Time** key; adjust time using the arrow keys. 
- Load food into oven.
- Press the **Start/Stop** key. 

NOTICE: TO SHUT THE OVEN OFF, PRESS AND HOLD  FOR FIVE SECONDS. THE RED LIGHT WILL APPEAR INDICATING THAT THE OVEN WILL BEGIN THE SHUT DOWN PROCESS.

TO FORCE SHUT DOWN IN THE RARE EVENT THE CONTROL LOCKS UP, PRESS AND HOLD  FOR TEN SECONDS.

PREVENTATIVE MAINTENANCE

Cleaning Agents	B-2
Preventative Maintenance	B-3
Protecting Stainless Steel	B-4
Cleaning Schedule	B-5
Ventless Hood Filters	B-6
Express Touch with CombiClean	B-7
Simple Control with CombiClean	B-8
Cleaning without CombiClean Program	B-9
Preventative Maintenance Checklist	B-10
Return to Main Table of Contents	ii

PREVENTATIVE MAINTENANCE

COMBICLEAN CLEANING AGENTS

CombiClean tablets are to be used *only* with the factory installed automatic cleaning option.



DANGER

ALWAYS wear rubber gloves when using CombiClean tablets or spray oven cleaner.



DANGER

ALWAYS wear protective eye wear when using spray oven cleaner.

NOTICE: Use authorized Combitherm cleaner only.

Unauthorized cleaning agents may discolor or harm interior surfaces of the oven. Read and understand label and material safety data sheet before using the oven cleaner.

CAUTION: Causes eye, skin, and respiratory tract irritation. keep out of reach of children.

PRECAUTIONS:

- Do not take internally.
- Avoid contact with eyes and skin.
- Use rubber gloves when using this product.
- Wash hands thoroughly after handling.
- Avoid mixing with strong, concentrated acids.

FIRST AID:

Skin: Flush with water. Remove contaminated clothing and do not re-wear until washed. If irritation persists see a physician.

Eyes: Flush with water for 15 minutes. See a physician immediately.

Inhalation: If difficulty in breathing occurs, leave area immediately and do not return until dust is settled. If irritation persists, see a physician.

Ingestion: Drink large quantities of milk or water. DO NOT INDUCE VOMITING. See a physician immediately.

PROTECTIVE PACKAGING OF TABLETS WILL BEGIN TO DISSOLVE ONTO SKIN IF HANDLED WITH DAMP OR WET HANDS.

PREVENTATIVE MAINTENANCE

PREVENTATIVE MAINTENANCE

In addition to the routine cleaning and maintenance procedures, there are several additional steps to be taken for both sanitation and to keep the oven running efficiently. Refer to the following inspection checklists for a comprehensive approach to longevity and equipment efficiency. These additional safeguards will help prevent down time and costly repairs.

DO NOT DISPOSE OF GREASE, FAT, WOOD CHIPS OR SOLID WASTE DOWN THE OVEN DRAIN.

Fats and solids will eventually coagulate in the drain system, causing blockage. Consequently, water will back-up into the condenser and interior oven compartment, resulting in an oven that is inoperable.

MAKE CERTAIN THE DRAIN SCREEN IS ALWAYS IN PLACE. REMOVE ANY SOLID WASTE MATERIAL FROM THE OVEN BOTTOM AND DRAIN SCREEN BEFORE IT ENTERS THE DRAIN SYSTEM.

The routine removal of solids from the drain screen will help prevent blockage.

USE THE AUTHORIZED COMBITHERM OVEN CLEANER ONLY.

The use of unauthorized cleaning agents may discolor or harm the interior surfaces of the oven.



WARNING

When smoking is completed, remove smoker box from oven. Dispose of wood chips in a fire proof waste receptacle to prevent the risk of fire.

TO PROLONG THE LIFE OF THE DOOR GASKET, CLEAN THIS ITEM DAILY.

The acids and related compounds found in fat, particularly chicken fat, will weaken the composition of the gasket unless cleaned on a daily basis. Wipe with a hot, soapy cloth.

TO ADDITIONALLY PROTECT GASKET LIFE, ALLOW OVEN DOOR TO REMAIN SLIGHTLY OPEN AT THE END OF THE PRODUCTION DAY.

An open door will relieve the pressure on the door gasket.

ROUTINELY CLEAN DOOR HINGES.

Open oven door to relieve tension. Clean all parts of the hinge.

ON A MONTHLY BASIS, DECALCIFIFY OR DESCALE THE OVEN.

Using the Scale Free cleaner, [CE-27889](#), place 7 ounces of the product in the drain. Run a **Heavy-Duty** cleaning cycle. After the cleaning cycle has been completed, use the hand shower to spray down the oven interior. Swing open the interior fan guard and spray down the area behind the panel. Direct a stream of water down the interior drain cover to thoroughly rinse the cleaner out of the oven. After the oven interior has been sprayed down, run a **RINSE** cleaning cycle.

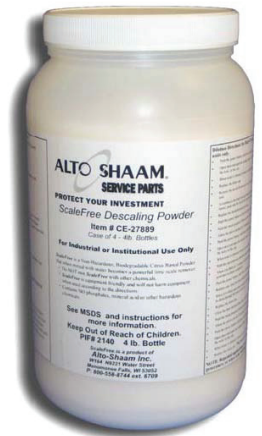

DANGER



To prevent **SERIOUS PERSONAL INJURY, DEATH, or PROPERTY DAMAGE:**

DO NOT steam clean, hose down or flood the interior or exterior with water or liquid solution of any kind. **DO NOT** use water jet to clean.

Failure to observe this precaution will void the warranty.

PREVENTATIVE MAINTENANCE

PROTECTING STAINLESS STEEL SURFACES



It is important to guard against corrosion in the care of stainless steel surfaces. Harsh, corrosive, or inappropriate chemicals can completely destroy the protective surface layer of stainless steel. Abrasive pads, steel wool, or metal implements will abrade surfaces causing damage to this protective coating and will eventually result in areas of corrosion. Even water, particularly hard water that contains high to moderate concentrations of chloride, will cause oxidation and pitting that result in rust and corrosion. In addition, many acidic foods spilled and left to remain on metal surfaces are contributing factors that will corrode surfaces.

Proper cleaning agents, materials, and methods are vital to maintaining the appearance and life of this appliance. Spilled foods should be removed and the area wiped as soon as possible but at the very least, a minimum of once per day. Always thoroughly rinse surfaces after using a cleaning agent and wipe standing water as quickly as possible after rinsing.

CAUTION



To protect stainless steel surfaces, completely avoid the use of abrasive cleaning compounds, chloride based cleaners, or cleaners containing quaternary salts. **NEVER** use hydrochloric acid (muriatic acid) on stainless steel. **NEVER** use wire brushes, metal scouring pads or scrapers.

CLEANING AGENTS

Use non-abrasive cleaning products designed for use on stainless steel surfaces. Cleaning agents must be chloride-free compounds and must not contain quaternary salts. Never use hydrochloric acid (muriatic acid) on stainless steel surfaces. Failure to observe this precaution will void the warranty. Always use the proper cleaning agent at the manufacturer's recommended strength. Contact your local cleaning supplier for product recommendations.

CLEANING MATERIALS

Cleaning can usually be accomplished with the proper cleaning agent and a soft, clean cloth. When more aggressive methods are needed, use a non-abrasive scouring pad on difficult areas and make certain to scrub with the visible grain of surface metal to avoid surface scratches. Never use wire brushes, metal scouring pads, or scrapers to remove food residue. Failure to observe this precaution will void the warranty.

WARNING



To prevent **SERIOUS INJURY, DEATH, or PROPERTY DAMAGE:**

The appliance must be cleaned thoroughly to avoid deposits of grease and or food residues inside the appliance that may catch fire. If fat deposits and/or food waste inside the appliance ignite, shut down the appliance immediately and keep the appliance door closed to extinguish the fire. If further extinguishing is required, disconnect the appliance from the main power and use a fire extinguisher (do not use water to extinguish a grease fire!). Failure to clean the appliance properly invalidates the warranty and relieves Alto-Shaam of all liability.

PREVENTATIVE MAINTENANCE

CLEANING SCHEDULE

DAILY GASKET CLEANING

It is important to prolong the life of the oven gasket by cleaning on a daily basis. Routine cleaning will help protect the gasket from deterioration caused by acidic foods.

1. Allow the oven to cool, then wipe the gasket and crevices with clean cloth soaked in warm detergent solution.
2. Wipe the gasket and crevices with a cloth and clean rinse water.

Do not attempt to remove gasket or place in the dishwasher.

PROBE USAGE AND CLEANING

After each use of the **CORE TEMP** mode, wipe the probe tip with a clean paper towel to remove food debris. Follow by wiping the probe with a disposable alcohol pad. Return the probe to the proper door bracket position. The probe cable should not be placed near the broiler element at the top of the oven.

Probe Cleaning Procedures

1. Remove all food debris from probe between loads and at the end of each production shift. Wipe the entire probe, probe cable assembly, and probe holding bracket with a clean cloth and warm detergent solution.
2. Remove detergent by wiping the probe, cable, and bracket with a cloth and clean rinse water.
3. Wipe probe and probe bracket with disposable alcohol pad or sanitizing solution recommended for food contact surfaces.
4. Allow probe and cable to air dry in the probe holding bracket. The probe cable should not be placed near the broiler element at the top of the oven.
5. Wipe the probe with a disposable alcohol pad prior to inserting into a new food product.

DAILY OVEN CLEANING

To be performed at the end of the production day or between production shifts.

CLEANING CYCLE NEEDED AFTER SMOKING

To prevent the transfer of smoke residue to non-smoked products, a cleaning cycle is required before cooking non-smoked items.

MONTHLY CLEANING

1. Spray Head
2. Drain Pipe

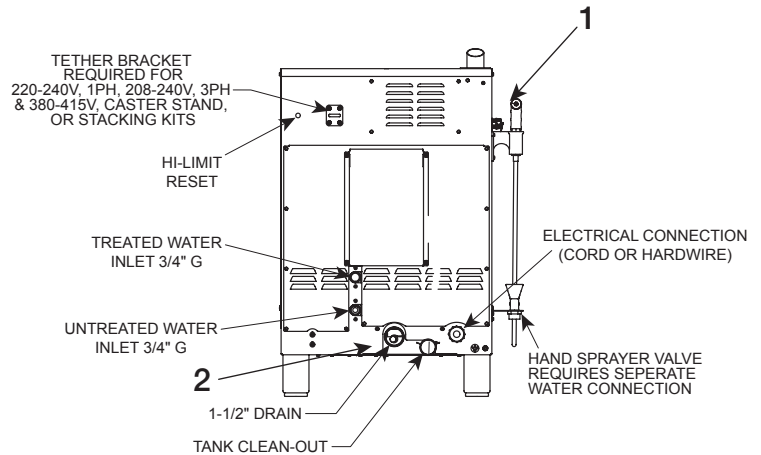

DANGER



To prevent **SERIOUS PERSONAL INJURY, DEATH, or PROPERTY DAMAGE:**

DO NOT steam clean, hose down or flood the interior or exterior with water or liquid solution of any kind. **DO NOT** use water jet to clean.

Failure to observe this precaution will void the warranty.

PREVENTATIVE MAINTENANCE

VENTLESS HOOD MODEL

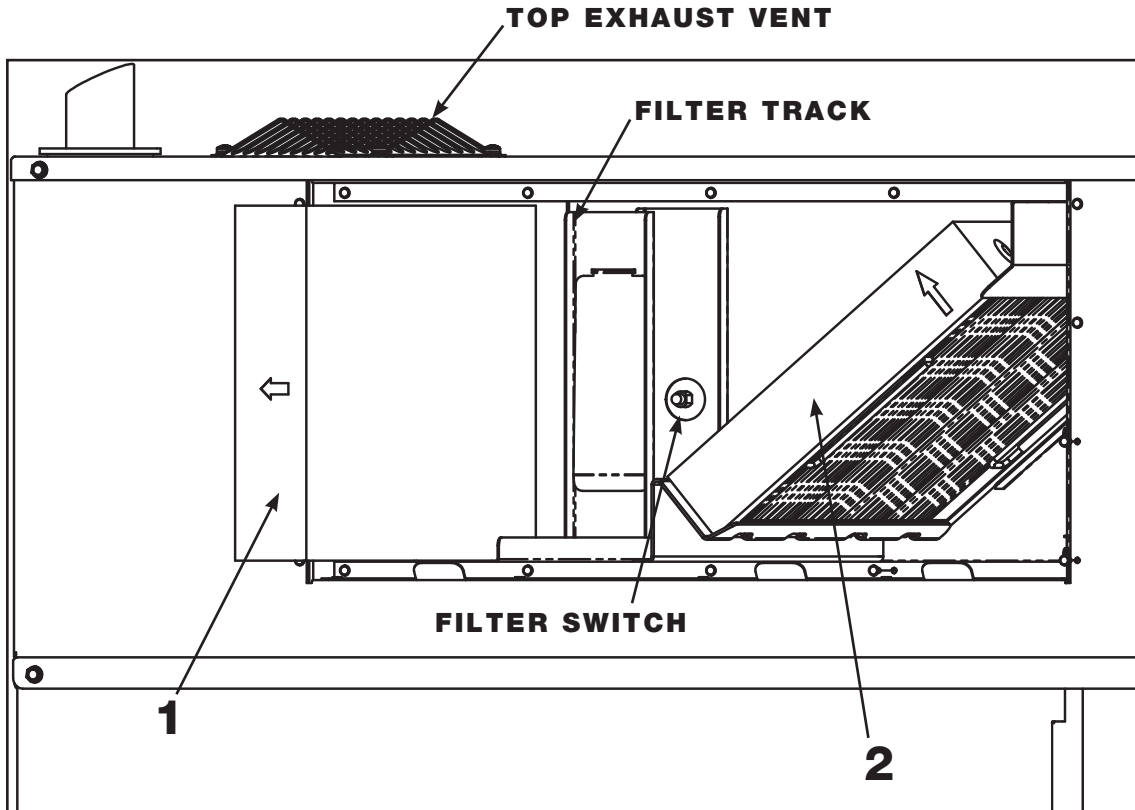

1. Charcoal Filter: The charcoal filter should be inspected for contaminant's on a regular basis. Replacement must be made at a minimum of three month intervals — more often if heavy contaminant's are visible or if the filter no longer controls odors.

To remove the charcoal filter, pull and slide out. When replacing the filter, ensure that the filter clip is in place at rear of the filter. Make certain the air flow arrow(s) point toward the hood fan (back of unit), and that the filter is replaced using the filter track in the metal back plate provided with the hood.

[FI-24114](#)

2. Grease Filter: Cleaning frequency should be based on oven usage with a maximum of two weeks between cleaning if the oven is used for non-grease laden products or steam applications only. Grease laden products require cleaning frequency of at least once a week.

Remove the grease filter by pulling it straight out of the housing. Place the filter in the dishwasher or wash separately by placing in hot, soapy water until all grease and particles have been removed. Rinse thoroughly. Allow the filter to air dry before reinstalling.

To replace the grease filter, the metal handles on the filter casing should be facing toward the front of the unit.

[FI-24113](#)

PREVENTATIVE MAINTENANCE

EXPRESSTOUCH WITH COMBICLEAN OPTION

Four (4) cleaning levels are offered: rinse, light, normal, and heavy-duty cleaning. CombiClean® tablets or Combitherm liquid spray cleaner may be used. Side racks and shelves may remain inside oven during cleaning. Remove solid wastes from the bottom of the oven and the drain screen to prevent blockage.

Notice: If a power outage were to occur during any of the cleaning cycles, the oven will begin a six (6) minute forced-rinse cycle.

 SELECT CLEANING MODE FROM ANY SCREEN.

NOTICE: If oven is too hot to safely clean, an oven with red interior will appear on the screen and the cool down function is automatically activated. Allow oven to cool to 200°F (93°C) before cleaning.

CLEANING MODE MENU

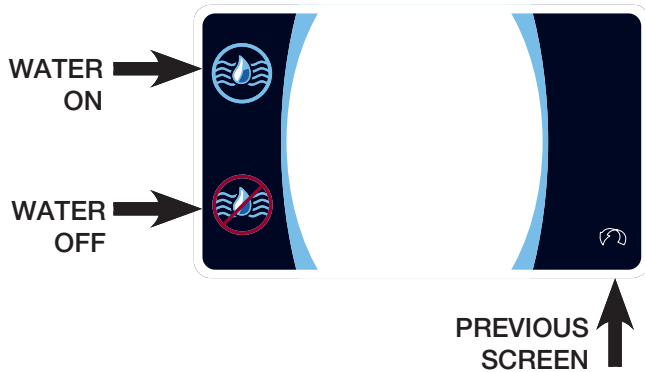

 PRESS WATER ON ICON TO CONFIRM THAT WATER SUPPLY IS TURNED ON.

OVEN TOO HOT WARNING

Must allow oven to cool down before inserting CombiClean tabs or spraying with cleaner

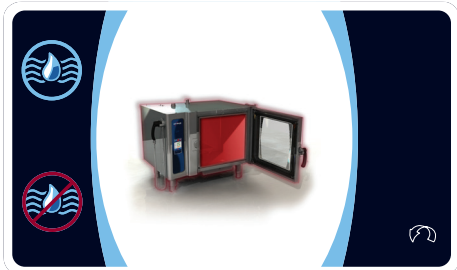

SELECT DESIRED LEVEL OF CLEANING.

 RINSE (20 MINUTES)

 LIGHT (30 MINUTES)

 NORMAL (1 HOUR 21 MINUTES)

 HEAVY-DUTY (2 HOURS 6 MINUTES)

INSERT APPROPRIATE NUMBER OF COMBICLEAN 1 OZ OR 0.5 OZ TABLETS as directed by touchscreen or spray interior of oven with combitherm liquid spray cleaner. User may add one additional tablet in either normal or heavy duty modes for particularly dirty ovens.

COMBI CLEANER REQUIREMENT

The number of required CombiClean tabs is shown.

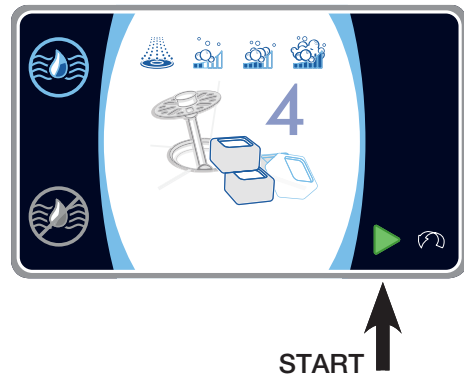

 TOUCH THE GREEN START ARROW ICON TO BEGIN CLEANING. Oven beeps when cleaning is finished. Leave door slightly ajar.

CLEANING IN PROCESS

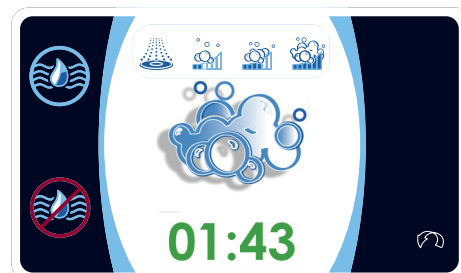

PREVENTATIVE MAINTENANCE

SIMPLE CONTROL WITH COMBICLEAN OPTION

One (1) heavy-duty cleaning cycle (2 hours 5 minutes) is offered. CombiClean® tablets or Combitherm liquid spray cleaner may be used. Side racks and shelves may remain inside oven during cleaning. Remove solid wastes from the bottom of the oven and the drain screen to prevent blockage.

Notice: If a power outage were to occur during any portion of the cleaning cycle, the oven will begin a six (6) minute forced-rinse cycle. Cook temperature display area will display "RIN". Cook time display area will display "--"

 SELECT CLEANING MODE.

NOTICE: If oven is too hot to safely clean, "door" will appear on the screen and the cool down function is automatically activated. Open the oven door to allow oven to cool to 200°F (93°C) before cleaning.

Cooking temperature display area will display "CLn". Cooking time display area will display "6" - referring to the number of cleaning tablets to insert.

Lift interior oven drain screen and insert six (6) COMBICLEAN TABLETS or spray interior of oven with Combitherm liquid spray cleaner. User may add one additional tablet for particularly dirty ovens.

Close oven door.

Press  key until the LED lights to begin cleaning cycle.

Cooking temperature display area will display "CLn".

Cooking time display area will display time remaining.

Oven beeps when cleaning is finished. Leave door slightly ajar.

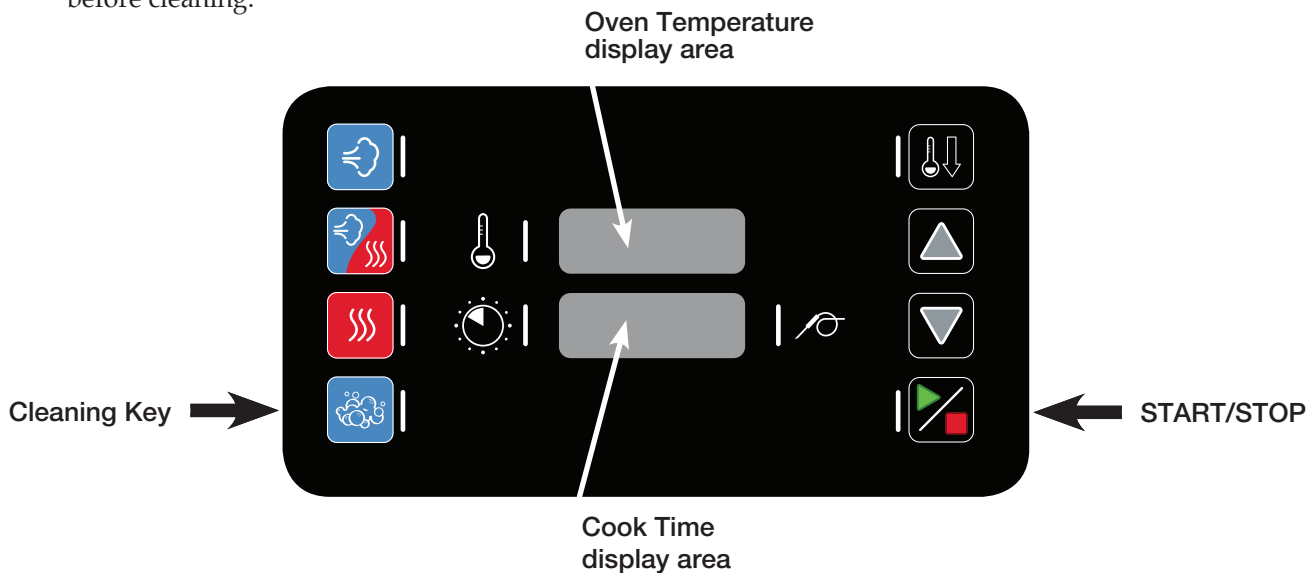

PREVENTATIVE MAINTENANCE

CLEANING - **WITHOUT** COMBICLEAN PROGRAM



The CT Express Combitherm can be ordered without the CombiClean® option. Combitherm liquid spray cleaner should be used.

NOTICE: If oven is too hot to safely clean, touch the cool down function key  to activate.

Open the oven door to allow oven to cool to 200°F (93°C) before cleaning.

Side racks and shelves may remain inside oven during cleaning. Remove solid wastes from the bottom of the oven and the drain screen to prevent blockage.

Wearing safety glasses and rubber gloves, generously spray the interior oven surfaces with an even coating of Combitherm Liquid Oven Cleaner. Spray all built in components, shelves, and side racks. Spray both sides of the oven.

- Securely close the oven door and let the solution stand for a minimum of 10 minutes.
- Press Power  on.
- Press Steam .
- Set Time  for ten minutes.
- Oven beeps for 3 minutes at the end of the steam cycle or until the door is opened or until a cook mode button is pressed.
- Open door.
- Make certain to thoroughly rinse all surfaces to remove any cleaning solution residue. Use a non-abrasive cleaning pad for any problem areas.
- Replace the side racks and shelves.
- Wipe door gasket with a hot, soapy cloth. Wipe again with a clean rinse cloth.
- Leave door slightly ajar to air dry.

DANGER



To prevent **SERIOUS PERSONAL INJURY, DEATH, or PROPERTY DAMAGE:**

DO NOT steam clean, hose down or flood the interior or exterior with water or liquid solution of any kind. **DO NOT** use water jet to clean.

Failure to observe this precaution will void the warranty.

More frequent preventative maintenance inspection/service is required when cooking large quantities of fatty foods. The acids and related compounds found in fat, particularly chicken fat, accumulate over time and can damage oven components.

ALTO-SHAAM – UNIT INFORMATION

Business Name:	-----
Model Number:	-----
Serial Number:	-----
Daily Inspection - Start Date:	-----

DAILY INSPECTION CHECKLIST

INSPECT & CLEAN:	<i>Monday</i>	<i>Tuesday</i>	<i>Wednesday</i>	<i>Thursday</i>	<i>Friday</i>	<i>Saturday</i>	<i>Sunday</i>
Product Probe (Thermometer)	<input type="checkbox"/>	<input type="checkbox"/>	<input type="checkbox"/>	<input type="checkbox"/>	<input type="checkbox"/>	<input type="checkbox"/>	<input type="checkbox"/>
Door Gasket (Inner Door Seal)	<input type="checkbox"/>	<input type="checkbox"/>	<input type="checkbox"/>	<input type="checkbox"/>	<input type="checkbox"/>	<input type="checkbox"/>	<input type="checkbox"/>
Inner Door Glass	<input type="checkbox"/>	<input type="checkbox"/>	<input type="checkbox"/>	<input type="checkbox"/>	<input type="checkbox"/>	<input type="checkbox"/>	<input type="checkbox"/>
Front Drip Tray	<input type="checkbox"/>	<input type="checkbox"/>	<input type="checkbox"/>	<input type="checkbox"/>	<input type="checkbox"/>	<input type="checkbox"/>	<input type="checkbox"/>
Touchscreen & Overlay <small>(Inspect for cracks, peeling, moisture, etc)</small>	<input type="checkbox"/>	<input type="checkbox"/>	<input type="checkbox"/>	<input type="checkbox"/>	<input type="checkbox"/>	<input type="checkbox"/>	<input type="checkbox"/>
Execute Automatic Wash Cycle <small>(With Approved Cleaning Chemical ONLY)</small>	<input type="checkbox"/>	<input type="checkbox"/>	<input type="checkbox"/>	<input type="checkbox"/>	<input type="checkbox"/>	<input type="checkbox"/>	<input type="checkbox"/>
EMPLOYEE INITIALS	-----	-----	-----	-----	-----	-----	-----





COMPONENT FAILURE & REPLACEMENT

List details of the failure(s) beside the day they occurred. (Leave blank if components are working properly)

<i>Monday</i>	
<i>Tuesday</i>	
<i>Wednesday</i>	
<i>Thursday</i>	
<i>Friday</i>	
<i>Saturday</i>	
<i>Sunday</i>	

More frequent preventative maintenance inspection/service is required when cooking large quantities of fatty foods. The acids and related compounds found in fat, particularly chicken fat, accumulate over time and can damage oven components.

ALTO-SHAAM – UNIT INFORMATION	
Business Name:	-----
Model Number:	-----
Serial Number:	-----
Weekly Inspection - Date:	-----

WEEKLY INSPECTION CHECKLIST	
Inspect - Oven Cavity Lamp	<input type="checkbox"/>
Inspect - Oven Cavity for signs of Grease/Carbon Buildup	<input type="checkbox"/>
Inspect - Behind the Fan Panel inside the Oven Cavity for signs of Grease/Carbon Buildup	<input type="checkbox"/>
Inspect - Behind the Fan Panel inside the Oven Cavity for signs of Scale Buildup	<input type="checkbox"/>
 Inspect - The Heat Exchanger for any signs of major deformation <u>(If Yes, IMMEDIATELY remove from service and take corrective action steps)</u>	<input type="checkbox"/>
 Inspect - The Heat Exchanger for any loose/disconnected pipes or flanges <u>(If Yes, IMMEDIATELY remove from service and take corrective action steps)</u>	<input type="checkbox"/>
 Inspect - Convection Elements for signs of cracking, deformation, or damage	<input type="checkbox"/>
 Clean Ventless Hood grease filters	<input type="checkbox"/>
EMPLOYEE INITIALS	

COMPONENT FAILURE & REPLACEMENT	
List details of the weekly failure(s) beside the week they occurred. (Leave blank if items are working properly)	
<i>Week 1</i>	
<i>Week 2</i>	
<i>Week 3</i>	
<i>Week 4</i>	

More frequent preventative maintenance inspection/service is required when cooking large quantities of fatty foods. The acids and related compounds found in fat, particularly chicken fat, accumulate over time and can damage oven components.





ALTO-SHAAM – UNIT INFORMATION	
Business Name:	-----
Model Number:	-----
Serial Number:	-----
Monthly Inspection - Date:	-----













MONTHLY INSPECTION CHECKLIST	
Inspect/Test - Proper Draining of the Oven Cavity	<input type="checkbox"/>
Inspect - All Drain Lines for Leaks or Clogs	<input type="checkbox"/>
<div style="border: 1px solid black; border-radius: 50%; padding: 2px; display: inline-block; margin-bottom: 5px;">ELEC. BOILER UNITS ONLY</div> Descal the Steam Generator	<input type="checkbox"/>
Inspect - Oven Cavity for any signs of Scale Buildup	<input type="checkbox"/>
Descal the Oven Interior	<input type="checkbox"/>
Inspect Ventless Hood paper filter (replace as needed)	<input type="checkbox"/>
Test Ventless Hood drain for proper drainage and signs of leaking	<input type="checkbox"/>
EMPLOYEE INITIALS	

COMPONENT FAILURE & REPLACEMENT
Summarize any component failure(s) that may have occurred during this month. (Leave blank if items are working properly)
<div style="text-align: center; font-size: small; color: gray; margin-top: 100px;"> <i>Summary of the month's component failure or replacement:</i> </div>

More frequent preventative maintenance inspection/service is required when cooking large quantities of fatty foods. The acids and related compounds found in fat, particularly chicken fat, accumulate over time and can damage oven components.

ALTO-SHAAM – UNIT INFORMATION	
Business Name:	-----
Model Number:	-----
Serial Number:	-----
12 Month Inspection - Date:	-----

TWELVE-MONTH INSPECTION CHECKLIST	
Replace - Steam Bypass Hose	<input type="checkbox"/>
Inspect - Cleaning Pump Hose	<input type="checkbox"/>
Inspect/Test - Proper Draining of the Oven Cavity	<input type="checkbox"/>
Inspect - <u>All</u> Drain Lines for Leaks or Clogs	<input type="checkbox"/>
Inspect - <u>All</u> Solenoid Hoses (Both Ends)	<input type="checkbox"/>
Inspect - Upper Browning Valve Hose	<input type="checkbox"/>
Inspect - Low Pressure Relief Valve & Hose	<input type="checkbox"/>
 Inspect - Convection Element Seal (from the electrical compartment)	<input type="checkbox"/>
 Inspect - Gas Heat Exchanger Seal (from the electrical compartment)	<input type="checkbox"/>
Inspect - N6 Oven Temperature Probe Seal	<input type="checkbox"/>
 Descal the Steam Generator	<input type="checkbox"/>
 Remove & Inspect - Steam Generator Elements	<input type="checkbox"/>
Inspect - Hand Shower Hose	<input type="checkbox"/>
Inspect - Hand Shower Handle	<input type="checkbox"/>
Inspect - Product Probe	<input type="checkbox"/>
Inspect - Water Injection Tube	<input type="checkbox"/>

	Inspect - Oven Cavity for any signs of Scale Buildup	<input type="checkbox"/>
	Inspect - Oven Cavity Lamp	<input type="checkbox"/>
	Inspect - Oven Cavity for signs of Grease/Carbon Buildup	<input type="checkbox"/>
	Inspect - Behind the Fan Panel inside the Oven Cavity for signs of Grease/Carbon Buildup	<input type="checkbox"/>
	Inspect - Behind the Fan Panel inside the Oven Cavity for signs of Scale Buildup	<input type="checkbox"/>
	Inspect - The Heat Exchanger for any signs of major deformation <u>(If Yes, IMMEDIATELY remove from service and take corrective action steps)</u>	<input type="checkbox"/>
	Inspect - The Heat Exchanger for any loose/disconnected pipes or flanges <u>(If Yes, IMMEDIATELY remove from service and take corrective action steps)</u>	<input type="checkbox"/>
	Inspect & Ensure - Exhaust Pipes are Exiting the Oven Cavity	<input type="checkbox"/>
	Inspect - Heat Exchanger Flange Gasket (Replace as Needed)	<input type="checkbox"/>
	Inspect & Tighten - Heat Exchanger Flange Bolts	<input type="checkbox"/>
	Inspect & Tighten - Heat Exchanger Burner Flange Hardware & Gasket (Replace as Needed)	<input type="checkbox"/>
	Inspect & Tighten - Heat Exchanger Igniter Flange Hardware & Gasket (Replace as Needed)	<input type="checkbox"/>
	Inspect - Heat Exchanger Exhaust Pipes (Ensure they are exiting out past the oven cavity ceiling flange) ESG models only	<input type="checkbox"/>
	Inspect - Oven Cavity Ceiling Flange & Flange Gasket - ESG models only	<input type="checkbox"/>
	Tighten - Burner Flange Bolts	<input type="checkbox"/>
	Tighten - Igniter Flange Bolts	<input type="checkbox"/>
	Inspect - Heat Exchanger Weep Holes to ensure they are free of obstructions <u>(If the hole is obstructed, IMMEDIATELY remove oven from service and replace the Heat Exchanger)</u> Not applicable to CTP/CTC models	<input type="checkbox"/>
	Inspect - Convection Elements for signs of cracking, deformation, or damage	<input type="checkbox"/>
	Replace - Oven Lamp Cover(s) & Gasket(s)	<input type="checkbox"/>
	Descale the Oven Interior	<input type="checkbox"/>
	Inspect - Door Gasket (Replace as Needed)	<input type="checkbox"/>
	Wipe Down the Inner Door Glass	<input type="checkbox"/>

Inspect - Front Drip Tray (Clean as Needed)	<input type="checkbox"/>
Inspect - Front Drip Tray Hose	<input type="checkbox"/>
Inspect - Control Overlay	<input type="checkbox"/>
Inspect & Tighten - All Electrical Connections	<input type="checkbox"/>
Inspect & Test - All cooling fans for proper operation	<input type="checkbox"/>
Inspect & Tighten - Door Hinges	<input type="checkbox"/>
Inspect & Tighten - Door Handle	<input type="checkbox"/>
Review - Error Code History	<input type="checkbox"/>
Note the Software Version (Update if Not Current)	<input type="checkbox"/>
Record - Water Pressure (Static & Dynamic)	<input type="checkbox"/>
Record - Line Voltage Across All Lines	<input type="checkbox"/>
Record - Line Voltage to Ground on Each Line	<input type="checkbox"/>
Record - Amperage Across All Three Legs (WHEN HEATING)	<input type="checkbox"/>
Function Test All Components (List Components)	<input type="checkbox"/>

COMPONENT FAILURE & REPLACEMENT

Note any component failure that was discovered during this twelve month inspection. (Leave blank if items are working properly)

Summary of the twelve month component failure or replacement:

Customer Signature _____

Technician Signature _____

ERROR CODES

Emergency Operation Mode C-2
Error Codes C-3
Return to Main Table of Contents ii

ERROR CODES

EMERGENCY OPERATION MODE

If the oven malfunctions, an error code will appear in the display. In the event of an error, the Combitherm may be operated on a limited basis. Error conditions under which continued operation is possible are indicated by "Yes" in the chart on the next page. To operate the oven in the event of an error code:



PRESS THE START ICON TO ACKNOWLEDGE THE ERROR.

The icons that begin to flash represent operational modes that are still usable.

SELECT ONE OF THE AVAILABLE COOKING MODES.

SET THE OVEN CONTROLS AS IF OPERATING UNDER NORMAL CIRCUMSTANCES.

Depending on the error code involved, oven function, such as temperature range, may be limited.



PRESS THE START ICON TO BEGIN COOKING.



PRESS THE STOP ICON WHEN TIMER EXPIRES.

The Combitherm will return to normal operation when the oven fault is corrected.

ERROR CODES

EMERGENCY OPERATION MODE (CONTINUED)

ERROR CODES

When the oven malfunctions, an error code will appear in the display.



PRESS THE START ICON TO ACKNOWLEDGE THE ERROR.

The icons that begin to flash represent operational modes that are still usable.

When the oven fault is corrected, the Combitherm will return to normal operation.

Error Code	Display Shows	Model		Mode			
		ES	ESG ESI	Steam	Combination	Convection	Retherm
E01	Low Water Boiler	Yes	No	No	No	To 365°F/185°C	No
E02	Control Temp High	Yes	Yes	No	No	No	No
E03	Fan Motor Error	Yes	Yes	No	No	No	No
E04	Fan Motor 2 Error	Yes	Yes	No	No	No	No
E11	Convection Temperature High	Yes	Yes	BOILER UNITS ONLY	No	No	No
E13	Boiler Temperature High	Yes	No	No	No	Yes	No
E15	Condenser Temperature High	Yes	Yes	No	No	To 356°F/180°C	No
E20	B11 Core Temperature Probe Single Point Fault - HACCP only	Yes	Yes	No	No	No	No
E21	N6 Cavity Probe Fault	Yes	Yes	BOILER UNITS ONLY	No	No	No
E22	B10 Core Temp Probe Fault	Yes	Yes	BY TIME ONLY	BY TIME ONLY	BY TIME ONLY	BY TIME ONLY
E23	B4 Boiler Probe Fault	Yes	No	No	No	No	No
E24	B5 Bypass Probe Fault	Yes	Yes	No	No	Yes	No
E25	B3 Condenser Probe Fault	Yes	Yes	Yes	No	To 356°F/180°C	No
E26	N8 Boiler Safety Temperature Probe Fault	Yes	No	No	No	No	No
E27	Boiler Element Temperature High	Yes	No	No	No	Yes	No
E34	Steam Generator Drain Pump Fault	Yes	No	No	No	No	No
E36	Steam Temperature High	Yes	No	No	No	Yes	No
E51	No Water in Boiler	Yes	No	No	No	Yes	No
E53	Fan Motor High Temperature	Yes	Yes	No	No	No	No
E54	Fan Motor 2 High Temperature	Yes	Yes	No	No	No	No
E55	Vent Not Open	Yes	Yes	Yes (NO BROWNING)	Yes (NO BROWNING)	Yes (NO BROWNING)	Yes (NO BROWNING)
E57	No Rinse Water	Yes	Yes	Yes	Yes	Yes	Yes
E93	Communication Error FROM Display Board	Yes	Yes	No	No	No	No
E94	Communication Error TO Display Board	Yes	Yes	No	No	No	No

ERROR CODES

ERROR CODES

If your Alto-Shaam® unit is not operating properly, check the following before calling your Authorized Alto-Shaam Service Agent:

- Check that unit is receiving power. Circuit breaker turned on?

NOTICE

This section is provided for the assistance of qualified and trained service technicians only and is not intended for use by untrained or unauthorized service personnel. Do not attempt to repair or service the oven beyond this point. Contact Alto-Shaam for the nearest authorized service agent. Repairs made by any other service agents without prior authorization by Alto-Shaam will void the warranty.

When the oven malfunctions, an error code will appear in the display.

 **PRESS THE START ICON TO ACKNOWLEDGE THE ERROR.**

When the oven error notification has been acknowledged, the Combitherm will attempt to return to normal operation.

Error Code	Error Call Out in Display	Description of Error	Possible Causes
E01	Low Water Boiler	Low water level in boiler	<ul style="list-style-type: none"> — Water supply is shut off. — Low water pressure. — Generator drain cap/hose missing or leaking. — Generator drain pump is defective. — Generator drain pump elbow leaking. — Fill solenoid not energized. — Fill solenoid faulty. — Wiring or connection error at the solenoid or the relay board. — Water level probe connection/wiring error at probe or relay board. — Water level probe requires descaling and/or replacement.
E02	Control Temperature High	Relay board surface temperature too high	<ul style="list-style-type: none"> — Cooling fan(s) not being energized. — Cooling fan(s) faulty. — Wiring/connection error at cooling fan(s). — Faulty relay board.
E03	Convection Fan Motor Error	Convection fan motor failure	<ul style="list-style-type: none"> — Motor VFD not energized. — No input signal to VFD from relay board. — Motor VFD faulty, not outputting to motor after input signal received. — Motor fan wheel blocked/obstructed. — Connection/wiring error at VFD, motor, hall effect sensor, relay board. — Faulty motor.
E04	Lower Convection Fan Motor Error	Lower convection fan motor failure on 20-20 unit	<ul style="list-style-type: none"> — Motor VFD not energized. — No input signal to VFD from relay board. — Motor VFD faulty, not outputting to motor after input signal received. — Motor fan wheel blocked/obstructed. — Connection/wiring error at VFD, motor, hall effect sensor, relay board. — Faulty motor.

(CONTINUED ON NEXT PAGE)

ERROR CODES

ERROR CODES

Error Code	Error Call Out in Display	Description of Error	Possible Causes
E11	Convection Temperature High	Oven cavity temperature N6 too high	<ul style="list-style-type: none"> — Convection element contactor stuck closed/on. — Faulty oven temperature probe connection at relay board. — Faulty N6 oven temperature probe. — Faulty relay board.
E13	Boiler Temperature High	Steam generator temperature too hot	<ul style="list-style-type: none"> — Immersion element is not submersed in water due to scale build up on the water level probe/ inside the tank. — Immersion element contactor stuck closed. — Faulty B4 steam generator temperature probe connection at relay board. — Faulty B4 temperature probe.
E15	Condensor Temperature High	Condensor water temperature too high	<ul style="list-style-type: none"> — Untreated water supply line is disconnected or shut off. — Cooling solenoid is not being energized when B3 probe is above set point. — Faulty B3 condensate temperature probe connection at relay board. — Faulty B3 condensate temperature probe.
E20	<p>HACCP Only - B11 Core Temperature Probe Single Point Fault</p> <p>Error E20 is not shown in display. Instead a probe sign with “?” is shown as popup window. In case the customer cooks in time mode during first step and during second step switches to probe mode but has no probe in place, the error E20 will be shown in the error code list and HACCP list.</p>	Single point core temperature probe defect or disconnected	<ul style="list-style-type: none"> — Probe not installed inside oven. — Faulty B11 Single Point Core Temperature probe receptacle connection at relay board. — Faulty B11 single point core temperature probe. — Debris buildup on probe receptacle pins inside of the oven.
E21	N6 Oven Cavity Temperature Probe Fault	N6 probe “open”	<ul style="list-style-type: none"> — Faulty N6 oven cavity temperature probe connection at relay board. — Faulty N6 oven temperature probe.
E22	B10 Core Temperature Probe Multipoint Fault	Multipoint core temperature probe defect or disconnected	<ul style="list-style-type: none"> — Faulty B10 multipoint core temperature probe connection at relay board. — Faulty B10 multipoint core temperature probe.
E23	B4 Boiler Probe Fault	B4 probe “open”	<ul style="list-style-type: none"> — Faulty B4 boiler temperature probe connection at relay board. — Faulty B4 boiler temperature probe.
E24	B5 Bypass Probe Fault	B5 probe “open”	<ul style="list-style-type: none"> — Faulty B5 steam bypass probe connection at relay board. — Faulty B5 steam bypass probe.
E25	B3 Condensor Probe Fault	B3 probe “open”	<ul style="list-style-type: none"> — Faulty B3 condensor probe connection at relay board. — Faulty B3 condensor probe.
E26	N8 Immersion Element Safety Probe Fault	N8 probe “open”	<ul style="list-style-type: none"> — Faulty N8 safety temperature probe connection at relay board. — Faulty N8 safety temperature probe.

(CONTINUED ON NEXT PAGE)

ERROR CODES

ERROR CODES

Error Code	Error Call Out in Display	Description of Error	Possible Causes
E27	N8 Immersion Element Temperature Too High	Immersion element too hot	<ul style="list-style-type: none"> — Scale buildup inside steam generator and/or on water level probe. — Immersion element contactor stuck closed. — Faulty N8 safety temperature probe.
E34	Steam Generator Drain Pump Fault	Water level in steam generator does not drop during cleaning program	<ul style="list-style-type: none"> — Scale buildup inside the steam generator and/or water level probe. — Obstruction on inlet side of steam generator drain pump. — Boiler steam generator pump not being energized. — Steam generator drain pump defective.
E36	Steam Temperature High	Oven cavity temperature is too high when operating in steam mode or combination mode	<ul style="list-style-type: none"> — Water supply is not connected or shut off. — Low water pressure. — Y1 solenoid valve not energized on a call for steam. — Y1 solenoid faulty. — Flow restrictor obstructed. — Water injection pipe obstructed. — Steam bypass hose obstructed. — B5 steam bypass probe dirty or faulty.
E51	No Water In Boiler	Steam generator fill error	<ul style="list-style-type: none"> — Water supply is disconnected or shut off. — Low water pressure. — Boiler drain cap leaking or missing. — Boiler drain pump defective. — Drain pump elbow leaking. — Fill solenoid not energized. — Fill solenoid faulty. — Connection/wiring error at the solenoid or the relay board. — Water level probe connection/wiring error at probe or the relay board. — Water level probe requires descaling and/or replacement.
E53	Fan Motor High Temperature	Fan motor high limit	<ul style="list-style-type: none"> — Faulty motor high limit connection at relay board. — Obstructed fan wheel. — Faulty convection motor.
E54	Lower Fan Motor High Temperature (20-20 unit size only)	Fan motor high limit	<ul style="list-style-type: none"> — Faulty motor high limit connection at relay board. — Obstructed fan wheel. — Faulty convection motor.
E55	Vent Not Open	Browning valve does not open	<ul style="list-style-type: none"> — Browning valve vent motor not being energized. — Alignment issue between motor cam and vent motor safety switch (micro switch). — Faulty connection at vent motor, vent motor switch or relay board. — Fault vent valve safety switch (micro switch). — Faulty vent motor.

(CONTINUED ON NEXT PAGE)

ERROR CODES

ERROR CODES

Error Code	Error Call Out in Display	Description of Error	Possible Causes
E57	No Rinse Water	During rinse no water flow is detected through solenoid valve	<ul style="list-style-type: none"> — Water supply is shut off. — Low water pressure. — Check wiring to all components mentioned below. — Flow switch is dirty or defective. — Double water solenoid valve defective (Y3.) — Relay board, high voltage, defective.
E92	Communication Error, RB Does Not Properly Respond	Communication error between display board and relay board	<ul style="list-style-type: none"> — Faulty ribbon cable connections between boards. — Faulty ribbon cable. — Relay board, low voltage, connector defective. — Display board connector defective.
E93	Communication Error, FROM Display Board	Communication error between display board and low voltage relay board	<ul style="list-style-type: none"> — Faulty ribbon cable connections between boards. — Faulty ribbon cable. — Relay board, low voltage, connector defective. — Display board connector defective.
E94	Communication Error, TO Display Board	Communication error between display board and low voltage relay board	<ul style="list-style-type: none"> — Faulty ribbon cable connections between boards. — Faulty ribbon cable. — Relay board, low voltage, connector defective. — Display board connector defective.
E98	RB is in Celsius and DB is in Fahrenheit	Change the unit configuration in the setup menu	<ul style="list-style-type: none"> — Control programming issue. — Ribbon cable defective. — Relay board, low voltage, connector defective. — Display board connector defective.
E99	RB is in Fahrenheit and DB is in Celsius	Change the unit configuration in the setup menu	<ul style="list-style-type: none"> — Control programming issue. — Ribbon cable defective. — Relay board, low voltage, connector defective. — Display board connector defective.
E100	DB version is not equal to RB version. Error generated by DB.	Software update may have failed.	<ul style="list-style-type: none"> — Perform software update. — Ribbon cable defective. — Faulty compact flash card. — Relay board, low voltage, connector defective. — Display board connector defective. — Software may need to be updated again.

(CONTINUED ON NEXT PAGE)

ERROR CODES

ERROR CODES

Error Code	Error Call Out in Display	Description of Error	Possible Causes
E101	DB version is not equal to RB version. Error generated by RB.	Software update may have failed.	<ul style="list-style-type: none"> — Perform software update. — Ribbon cable defective. — Faulty compact flash card. — Relay board, low voltage, connector defective. — Display board connector defective. — Software may need to be updated again.
E102	Ventless Hood Fault — Filters Not Present	Filter safety switches are not properly activated.	<ul style="list-style-type: none"> — Grease and/or charcoal filter not installed. — Faulty filter switch. — Poor connection at safety switch or relay board.
E103	Ventless Hood Fault — Pressure Failure	Ventless hood operation failure.	<ul style="list-style-type: none"> — Hood power switch not turned to the on position. — Hood power switch defective. — Hood fan not operating. — Filter(s) clogged/need replacement. — Pressure switch tube plugged or disconnected. — Faulty pressure switch or connection error/failure. — Hood fan turning in the wrong direction.
E104	Ignition Failure	Attempt for ignition.	<ul style="list-style-type: none"> — Gas supply disconnected or turned off. — Gas supply pressure too low/too high. — Gas valve not being energized by ignition control. — Ignition control not creating a spark. — Faulty spark wire and/or igniter. — Faulty flame sense wire or sensing wire connection. — Faulty ignition control. — Blocked or obstructed flue pipe(s).
E105	Low Water Pressure	Low or no water pressure to oven.	<ul style="list-style-type: none"> — Water supply not connected or turned off. — Water pressure too low. — Solenoid valve not being energized. — Solenoid valve not opening. — Pressure switch faulty. — Poor connection at pressure switch and/or relay board.
E106	Cleaning Pump Fault	Cleaning pump is not running.	<ul style="list-style-type: none"> — Cleaning pump motor not being energized. — Cleaning pump faulty. — Poor connection at pump motor and/or relay board. — Hall effect sensor wiring/connection error/failure.
E107	Boiler Drain Pump Fault	Boiler drain pump is not running.	<ul style="list-style-type: none"> — Boiler drain pump motor not being energized. — Boiler drain pump faulty. — Poor connection at pump motor and/or relay board. — Hall effect sensor wiring/connection error/failure.

TROUBLESHOOTING TREES

No Convection Heat (1 PH)	D-2
No Convection Heat (208-240V, 3 PH)	D-3
No Convection Heat (380-415V, 3 PH)	D-4
No Convection Element Heat with Retherm Option (208-240V, 3 PH)	D-5
No Convection Element Heat with Retherm Option (380-415V, 3 PH)	D-6
No Steam Operation (1 PH)	D-7
No Steam Operation (208-240V, 3 PH)	D-8
No Steam Operation with Retherm Option (208-240V, 3 PH)	D-9
No Steam Operation (380-415V, 3 PH)	D-10
No Steam Operation with Retherm Option (380-415V, 3 PH)	D-11
Too Much Steam Production	D-12
No Smoke	D-13
No Catalytic Converter Operation	D-14
Two Speed Motor - No High Speed Motor Operation	
- with motor protection switch	D-15
- without motor protection switch	D-16
Two Speed Motor - No Low Speed Motor Operation	
- with motor protection switch	D-17
- without motor protection switch	D-18
Single Speed Motor - No Motor Operation	
- with motor protection switch	D-19
- without motor protection switch	D-20
No Display/Control Not Powering On (Unit Dead).	D-21
No Display/No Operation - Simple Control	D-22
No Browning Vent Motor Operation	D-23
No Oven Lamp	D-24
No Condensate Injection (E15 Error Code).	D-25
No Cleaning Operation	D-26
No Cooling Fan Operation	D-27
No Hood Operation	D-28
Hood Door Safety Latch Not Closing	D-29
Hood Door Safety Latch Not Releasing	D-30
No Browning Bar Heat (280-240V, 3 PH)	D-31
No Browning Bar Heat (380-415V, 3 PH)	D-32
K-77 Safety Contactor Troubleshooting (380-415V Only).	D-33
Return to Main Table of Contents	ii

TROUBLESHOOTING TREES

No Convection Heat (1PH)

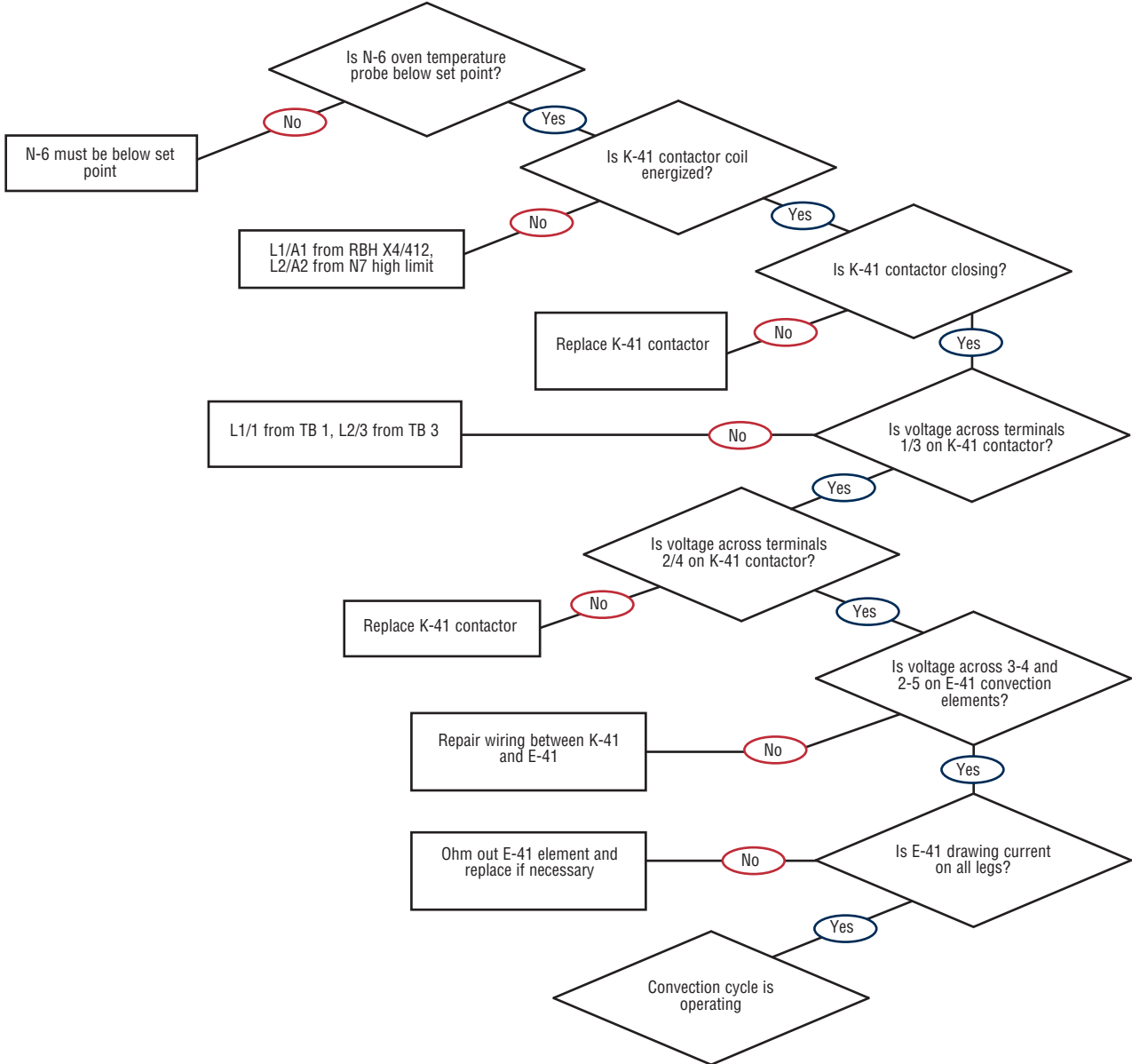

TROUBLESHOOTING TREES

No Convection Heat (208-240V, 3PH)

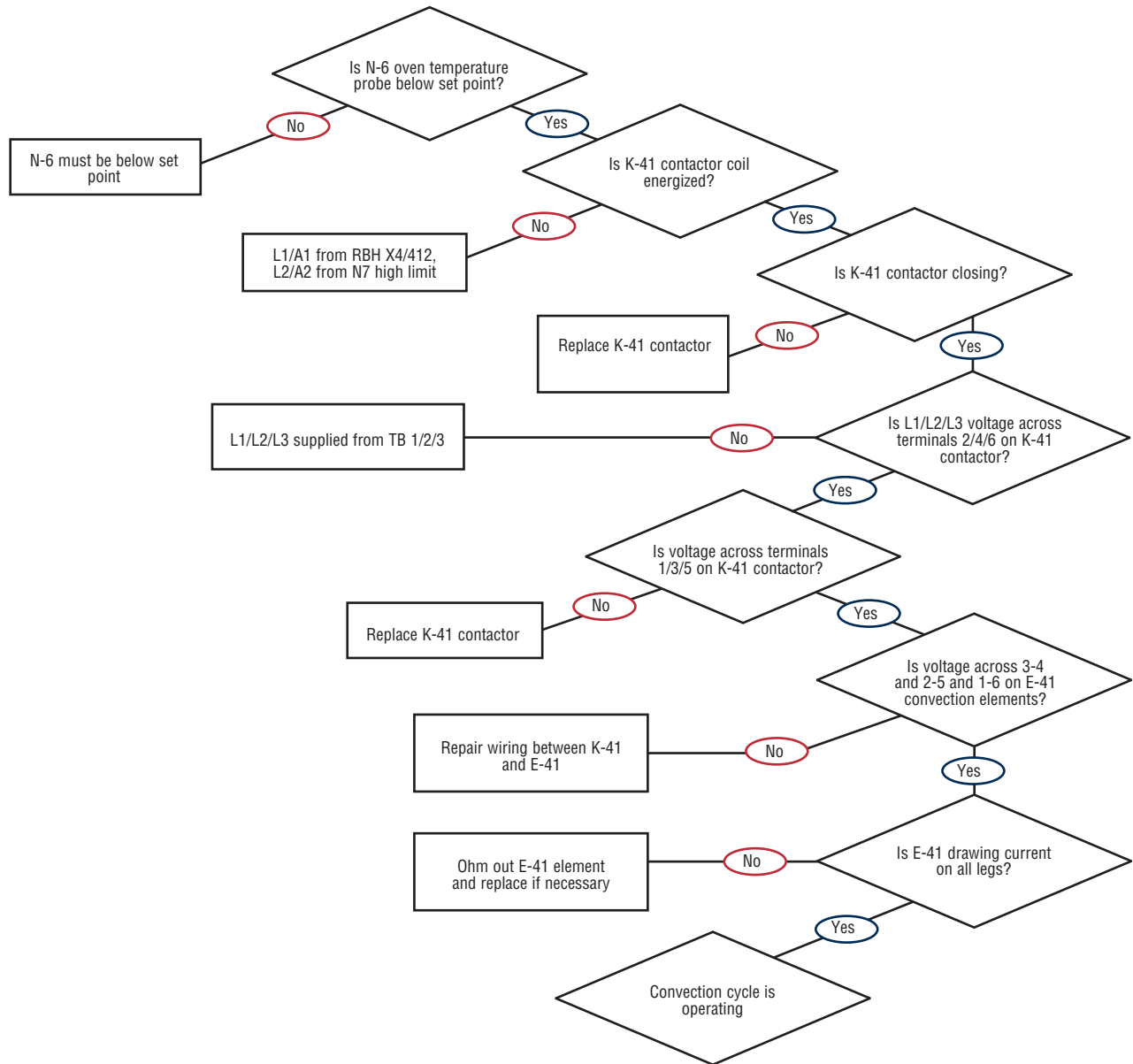

TROUBLESHOOTING TREES

No Convection Heat (380-415V, 3PH)

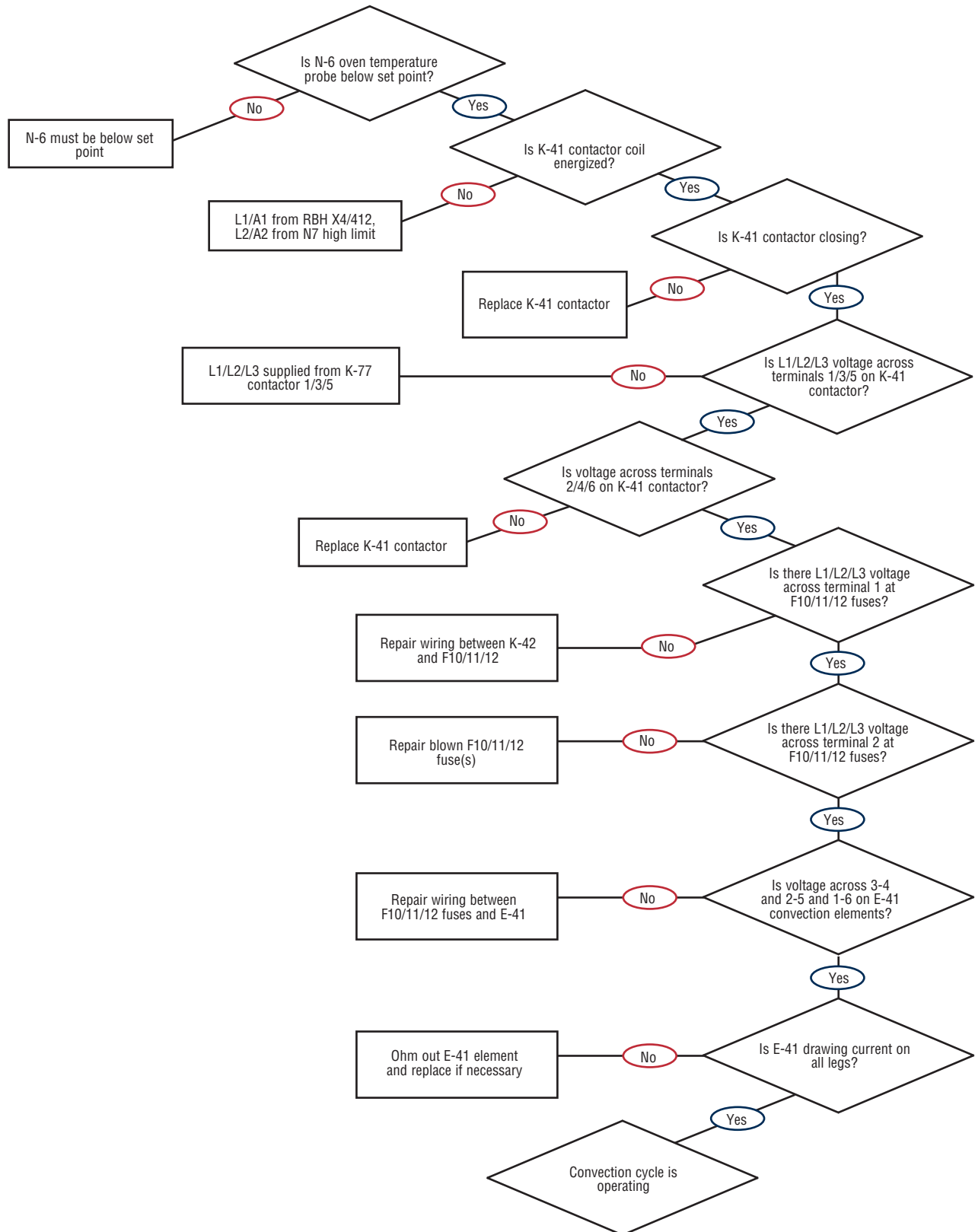

TROUBLESHOOTING TREES

No Convection Element Heat with Retherm Option (208-240V, 3PH)

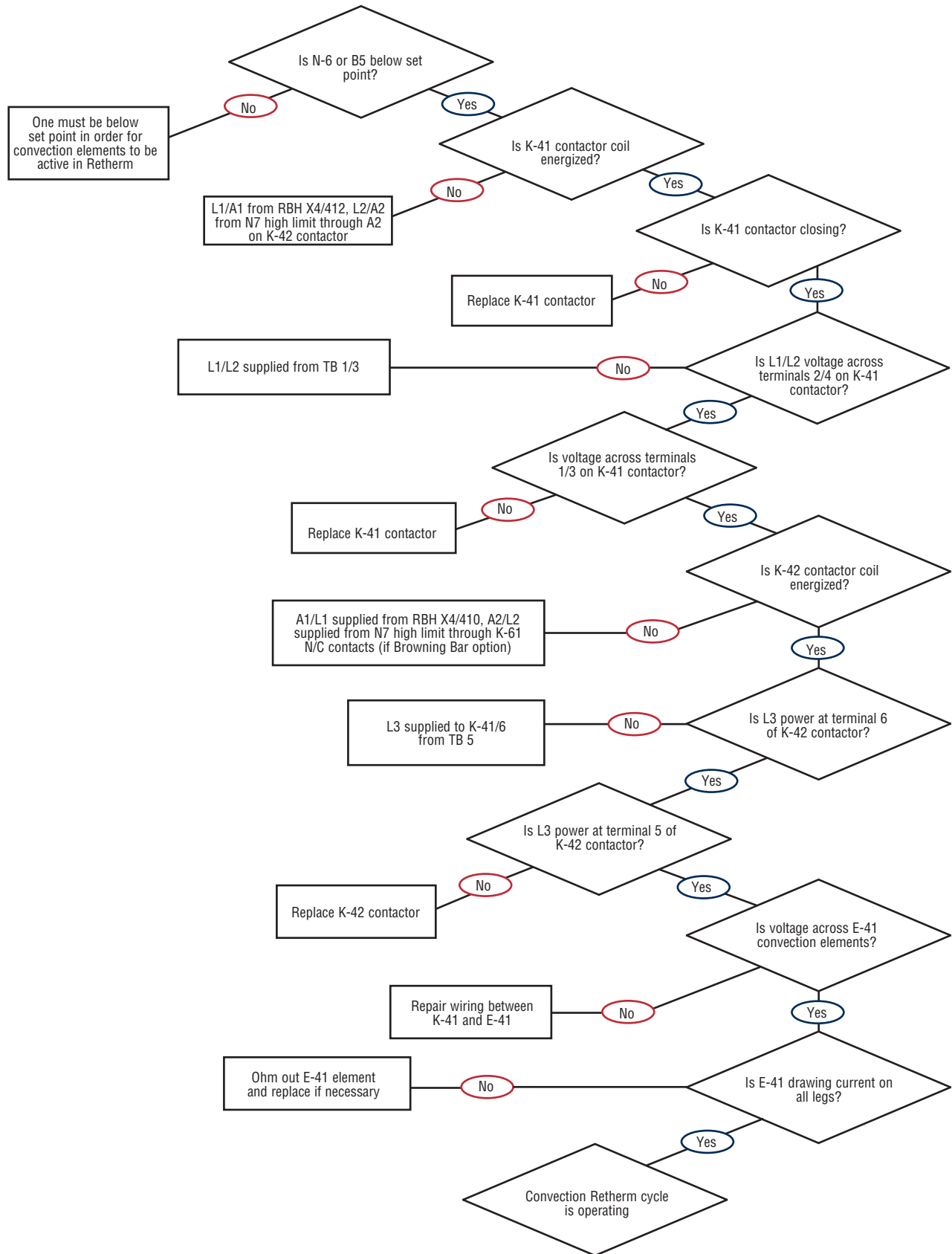

TROUBLESHOOTING TREES

No Convection Element Heat with Retherm Option (380-415V, 3PH)

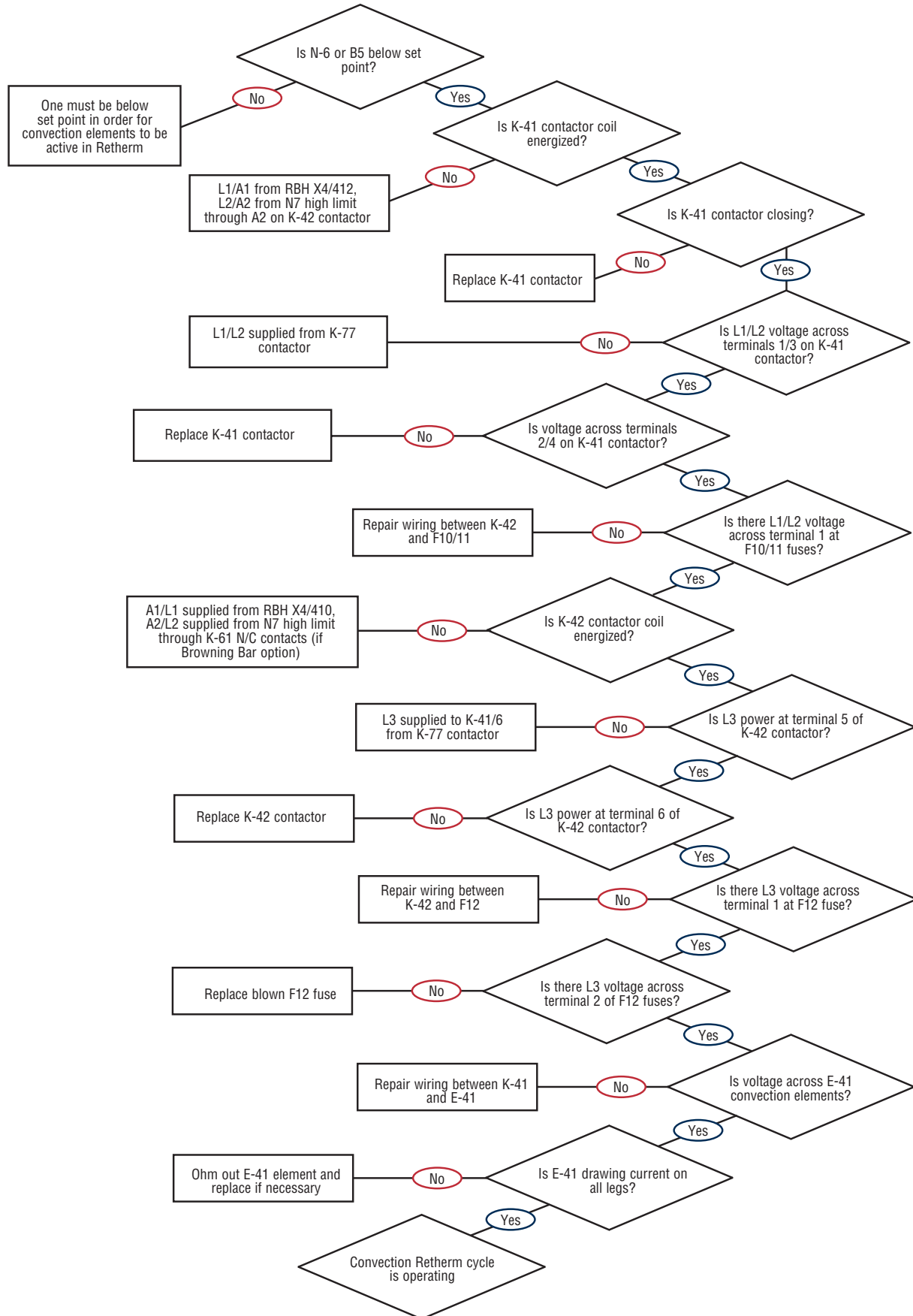

TROUBLESHOOTING TREES

No Steam Operation (1PH)

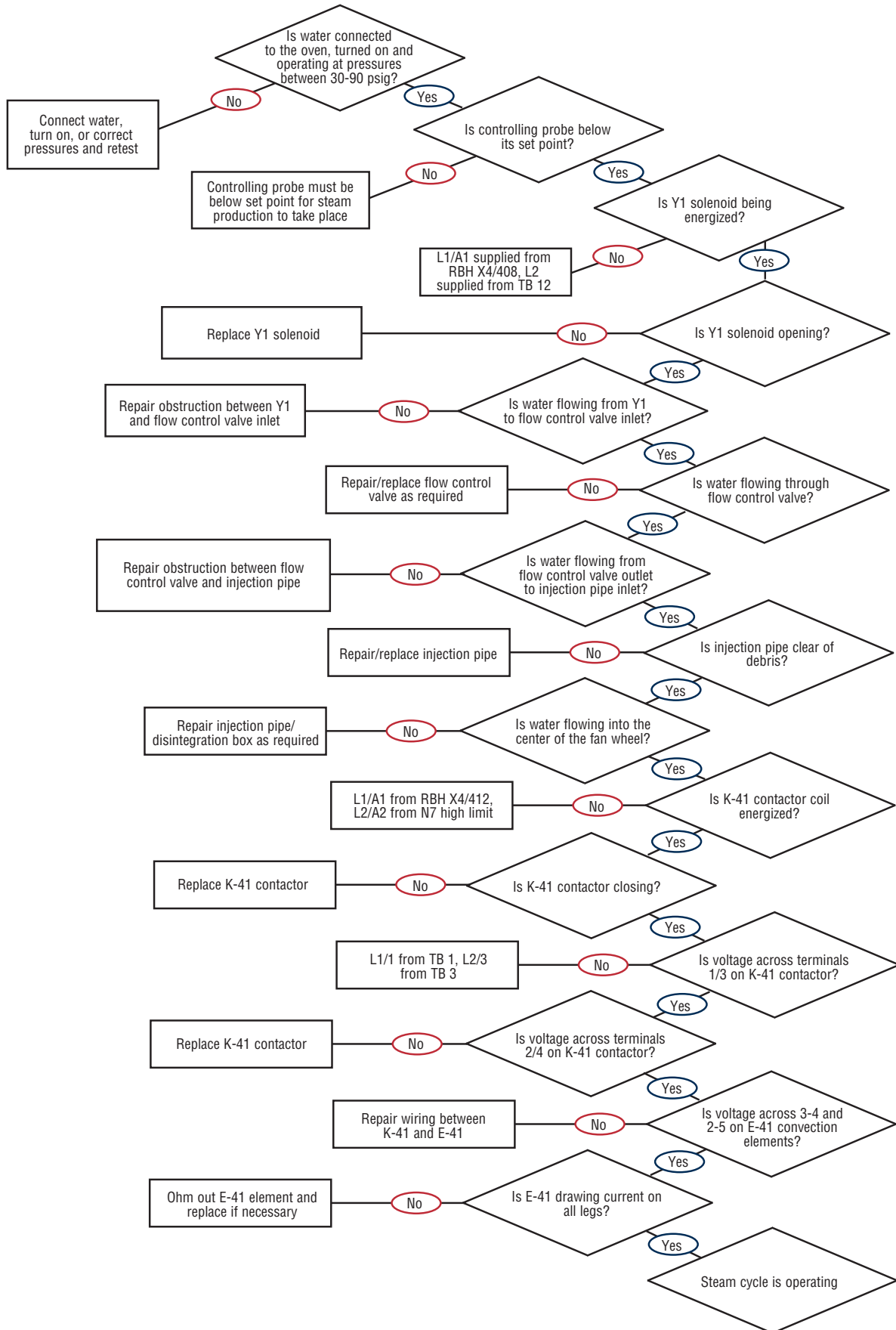

TROUBLESHOOTING TREES

No Steam Operation (208-240V, 3PH)

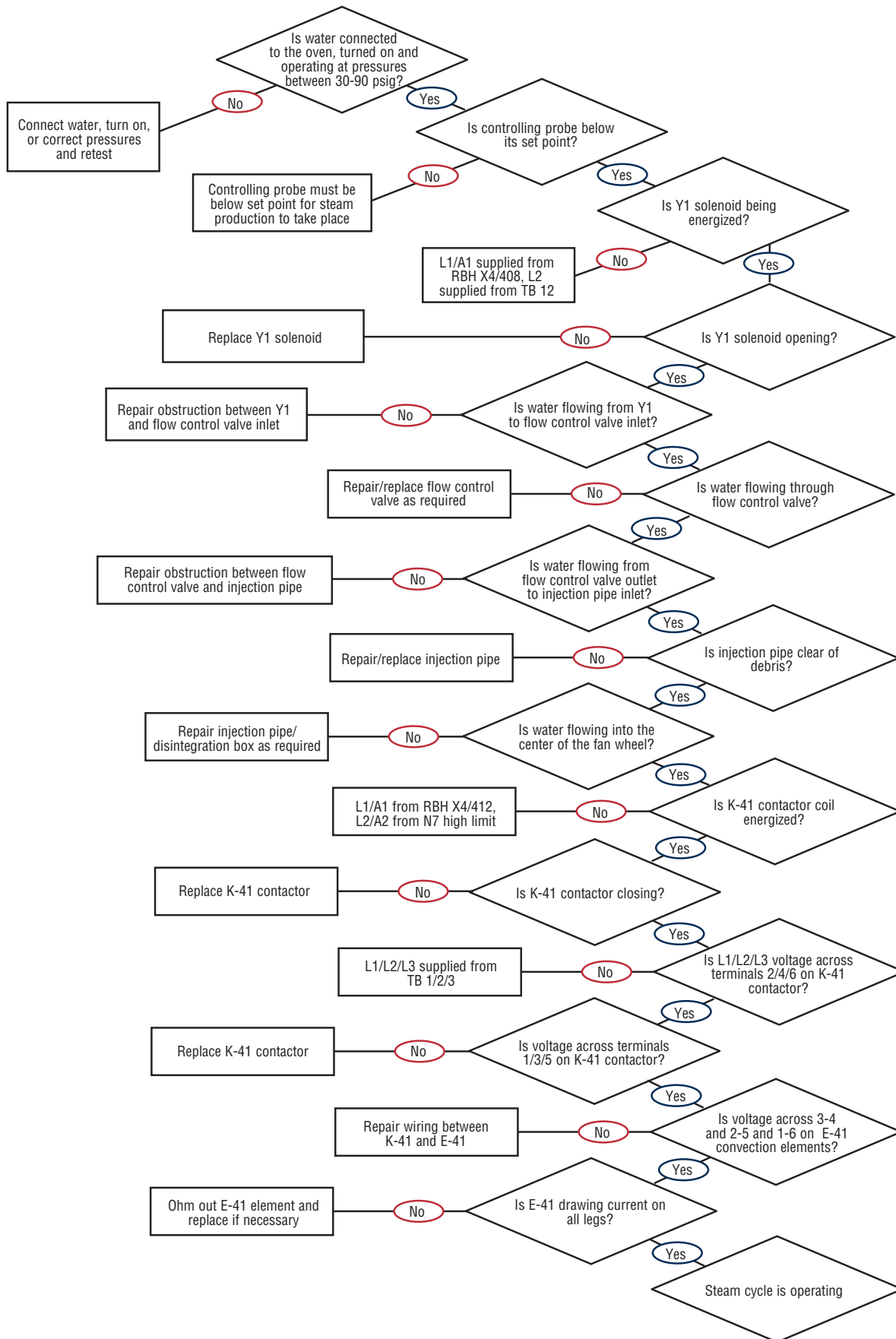

TROUBLESHOOTING TREES

No Steam Operation with Retherm Option (208-240V, 3PH)

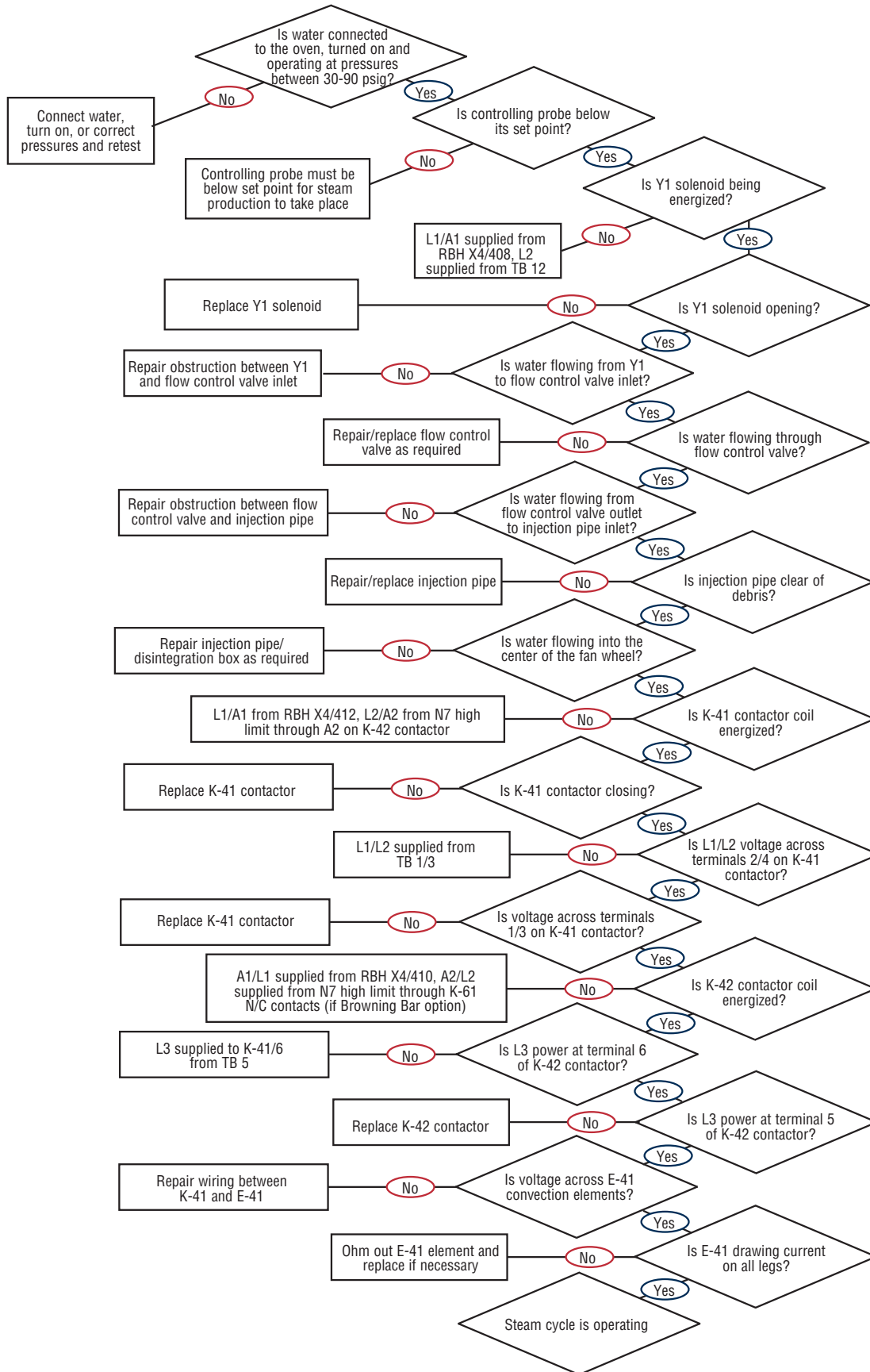

TROUBLESHOOTING TREES

No Steam Operation (380-415V, 3PH)

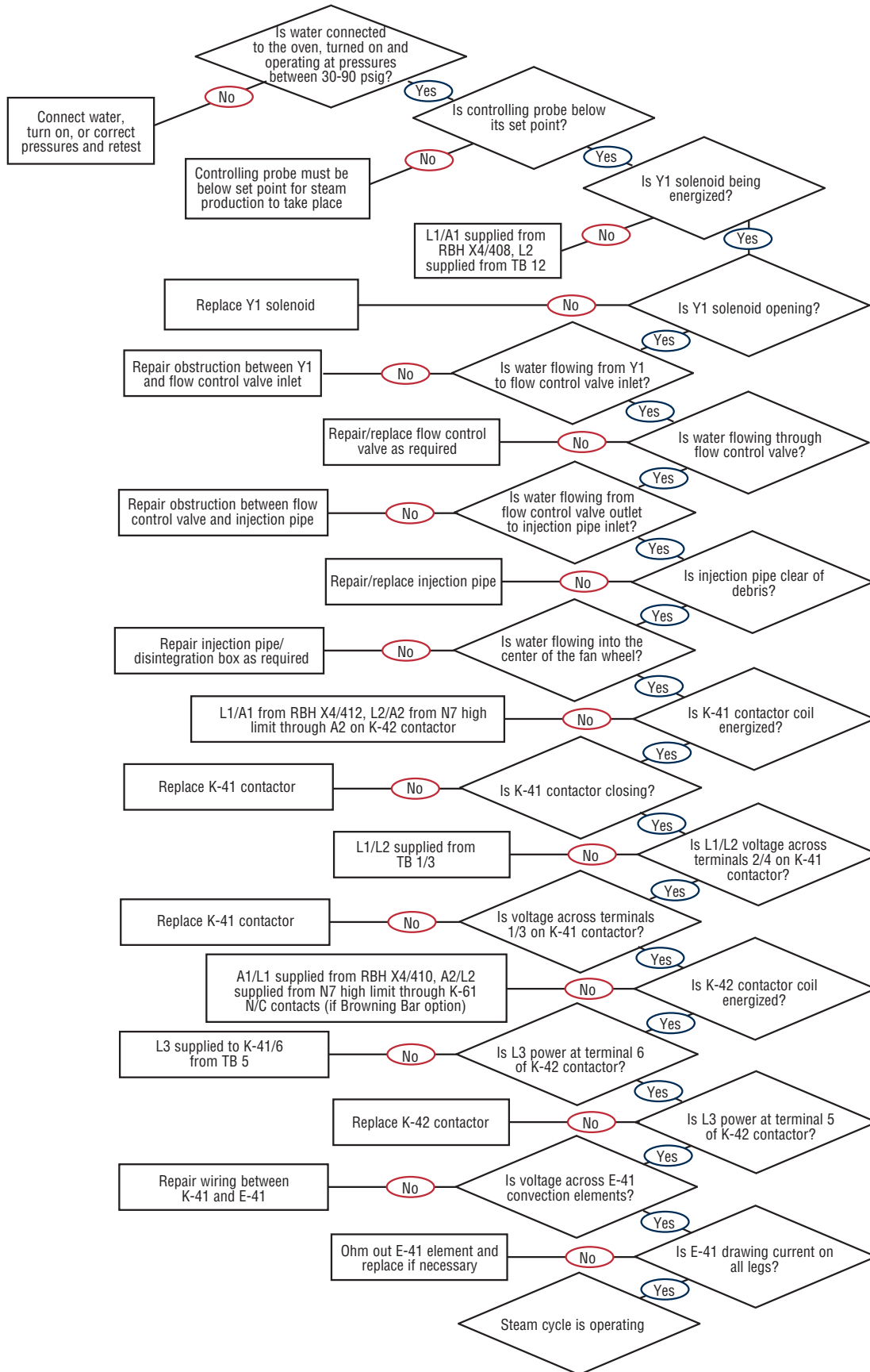

TROUBLESHOOTING TREES

No Steam Operation with Retherm Option (380-415V, 3PH)

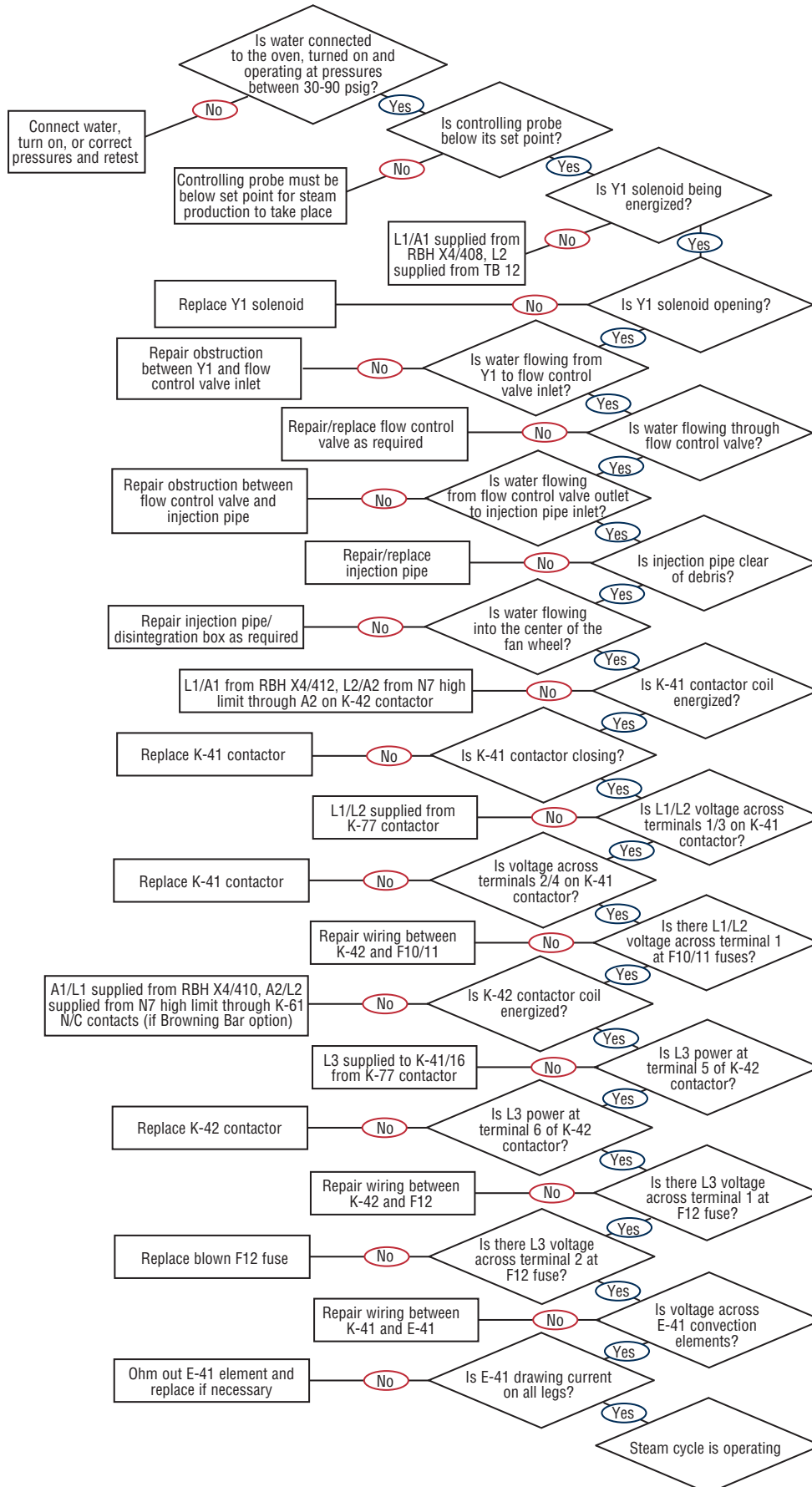

TROUBLESHOOTING TREES

Too Much Steam Production

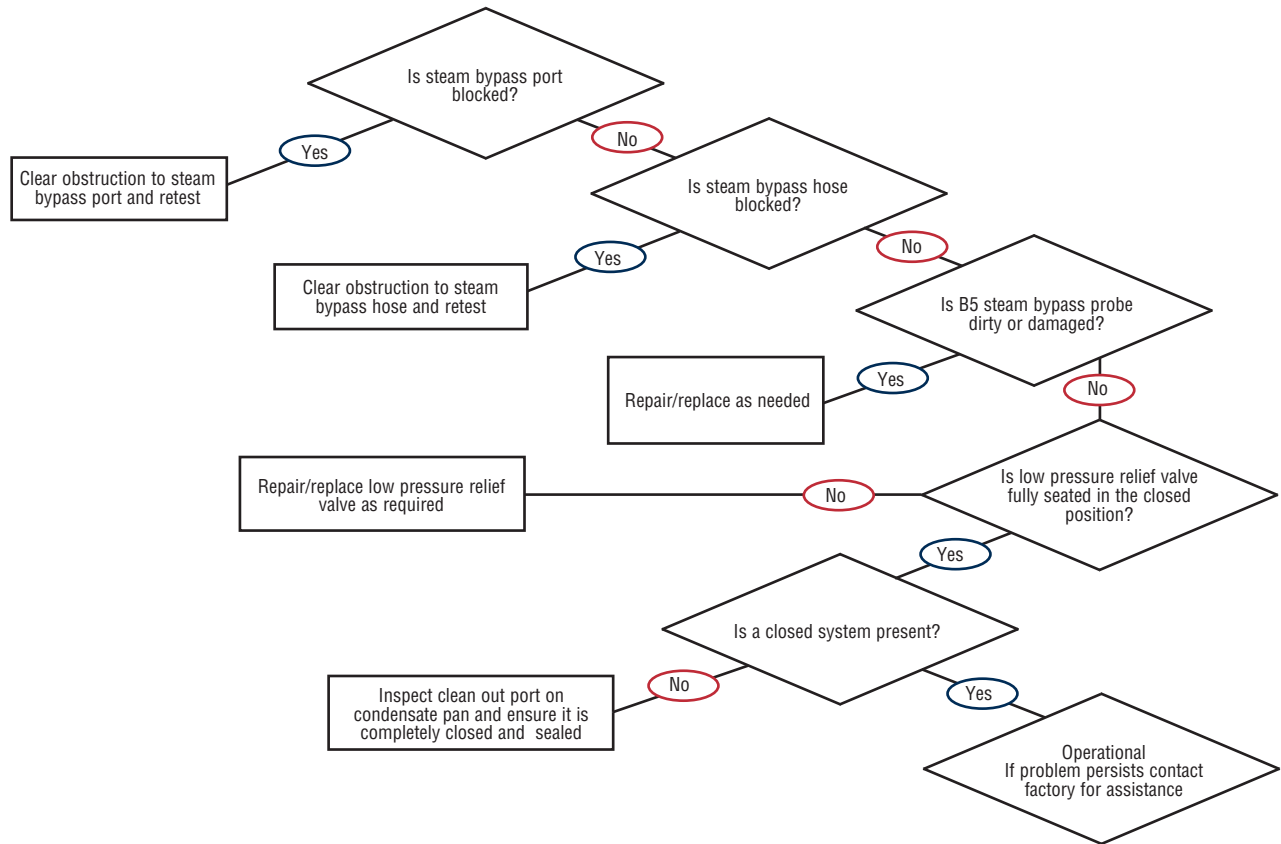

TROUBLESHOOTING TREES

No Smoke

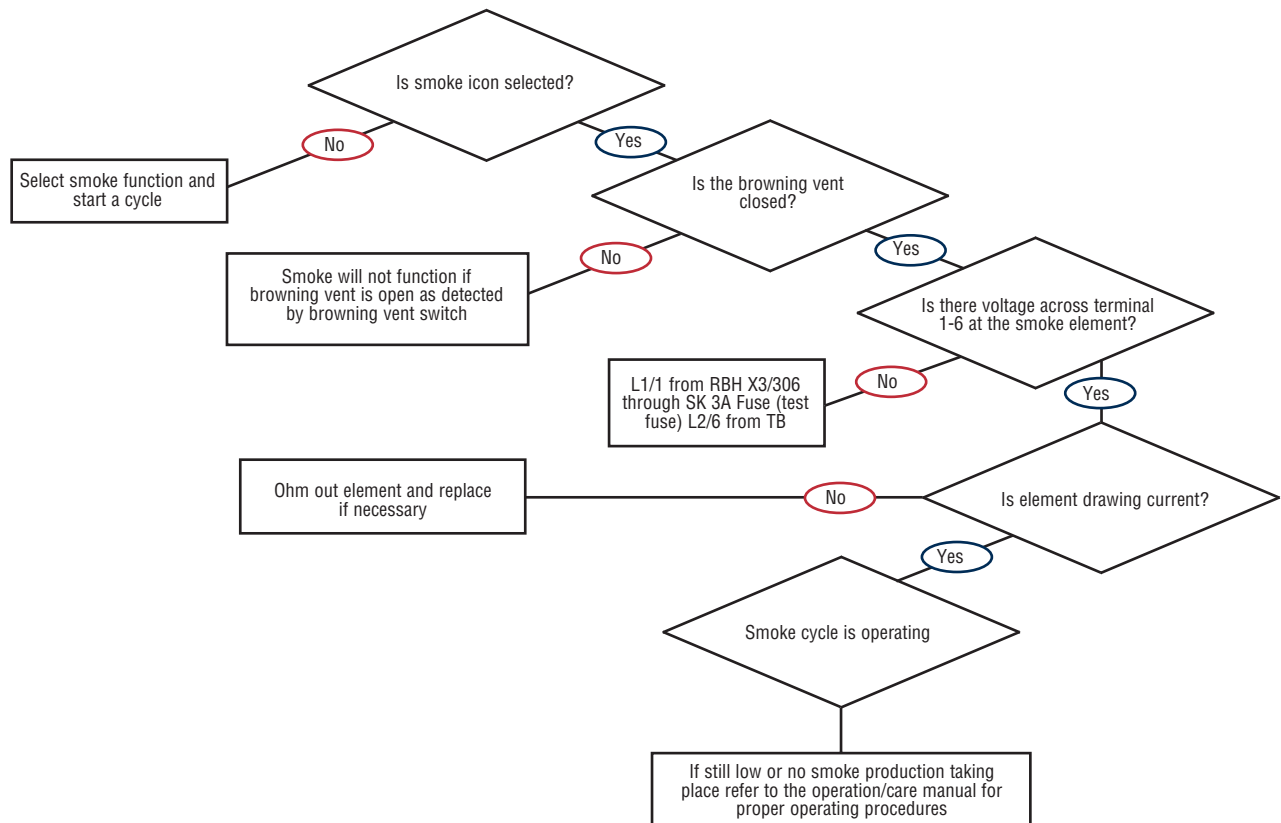

TROUBLESHOOTING TREES

No Catalytic Converter (CC) Operation

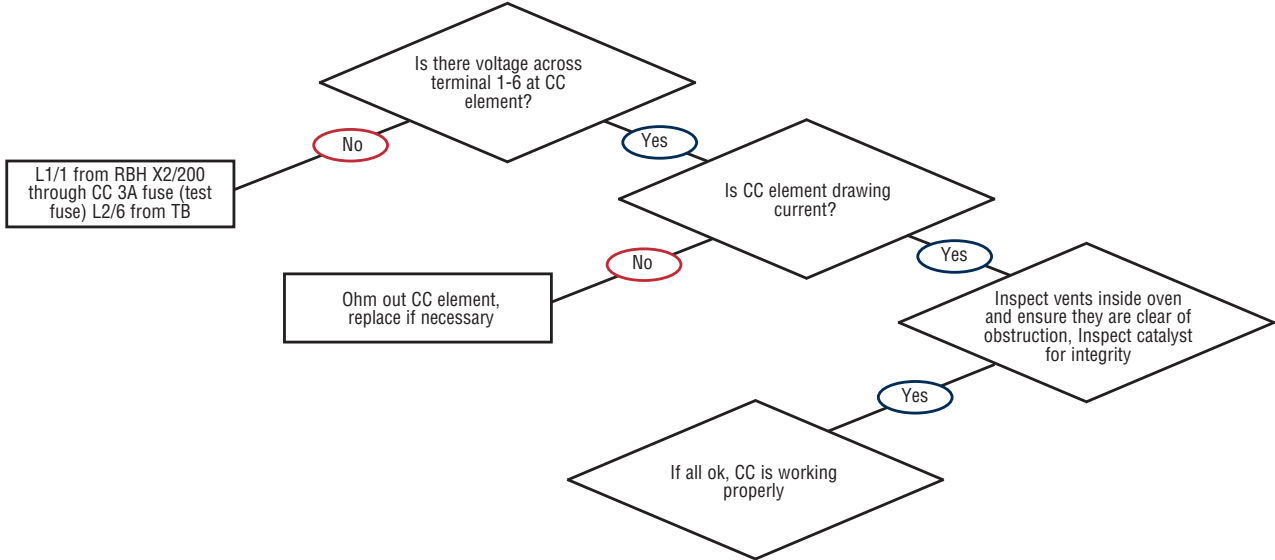

TROUBLESHOOTING TREES

Two Speed Motor - No High Speed Motor Operation (with motor protection switch)

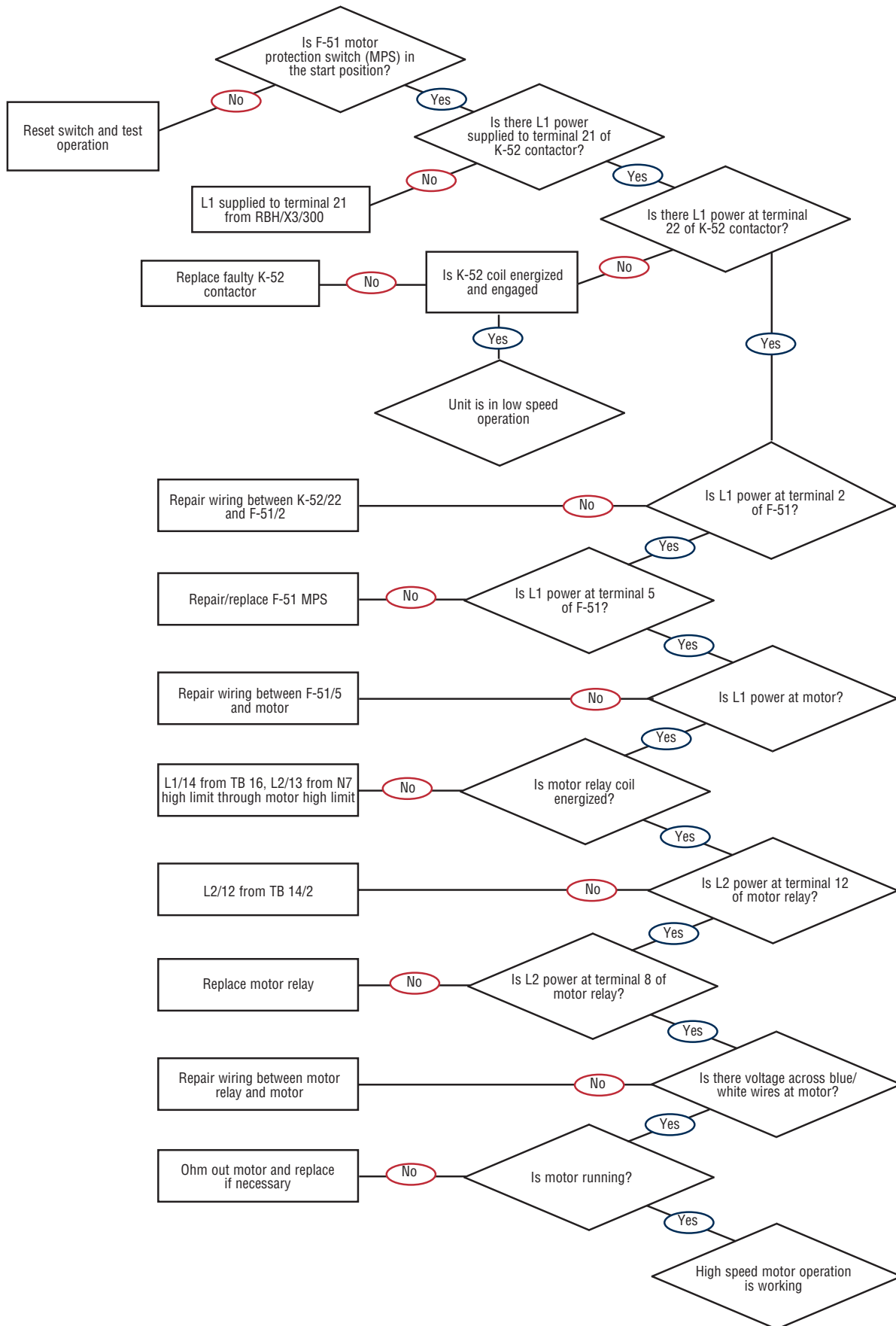

TROUBLESHOOTING TREES

Two Speed Motor - No High Speed Motor Operation (without motor protection switch)

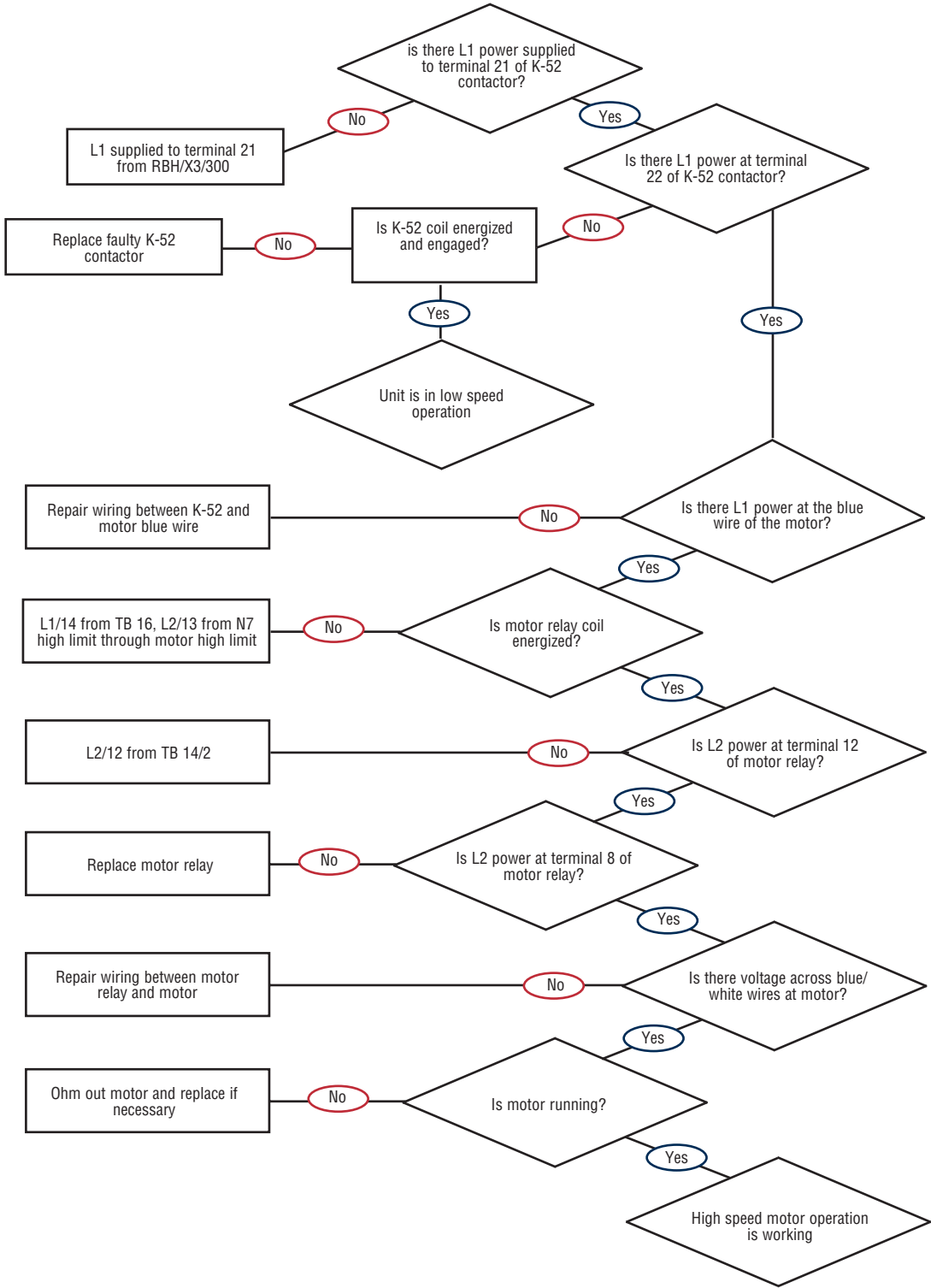

TROUBLESHOOTING TREES

Two Speed Motor - No Low Speed Motor Operation (with motor protection switch)

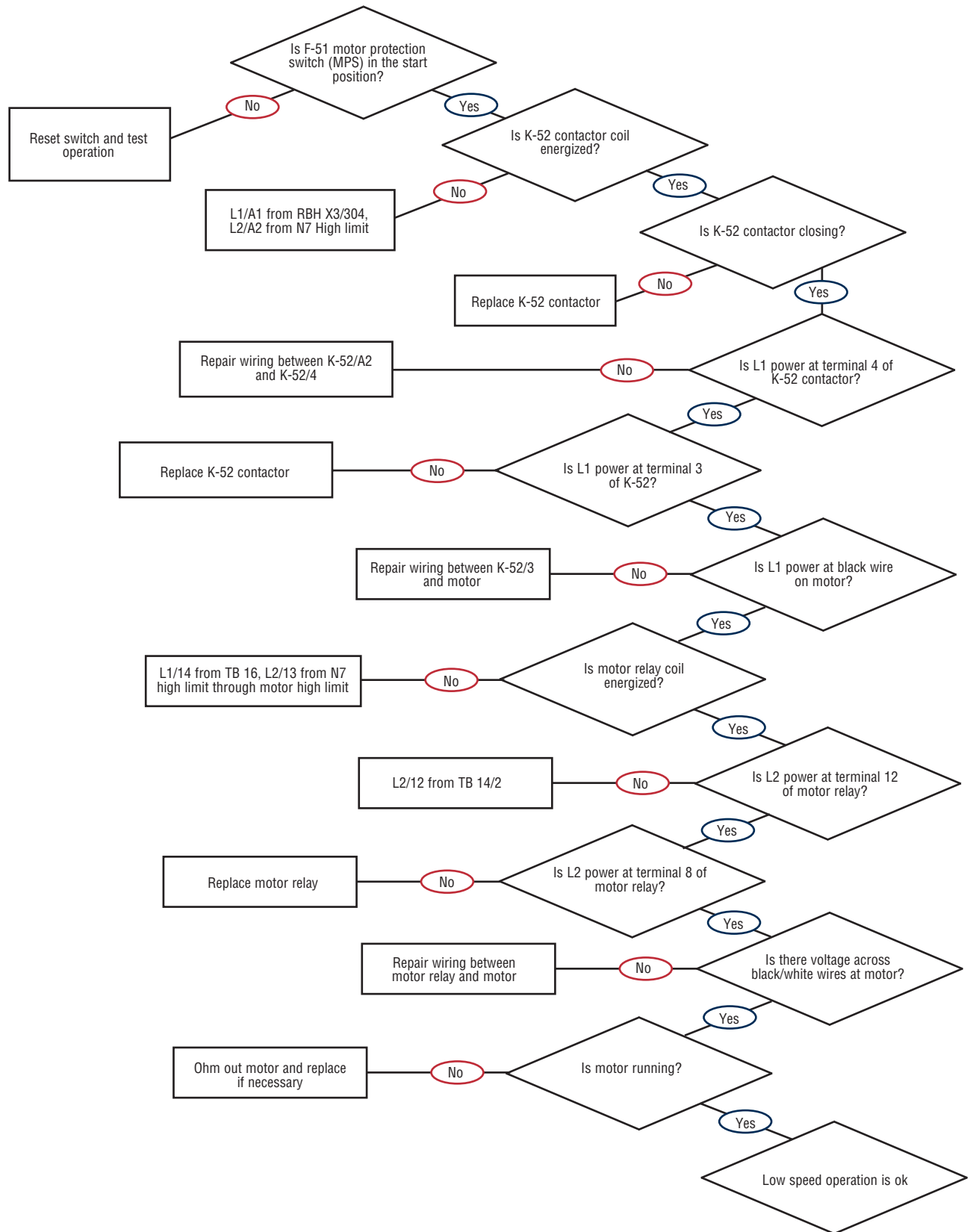

TROUBLESHOOTING TREES

Two Speed Motor - No Low Speed Motor Operation (without motor protection switch)

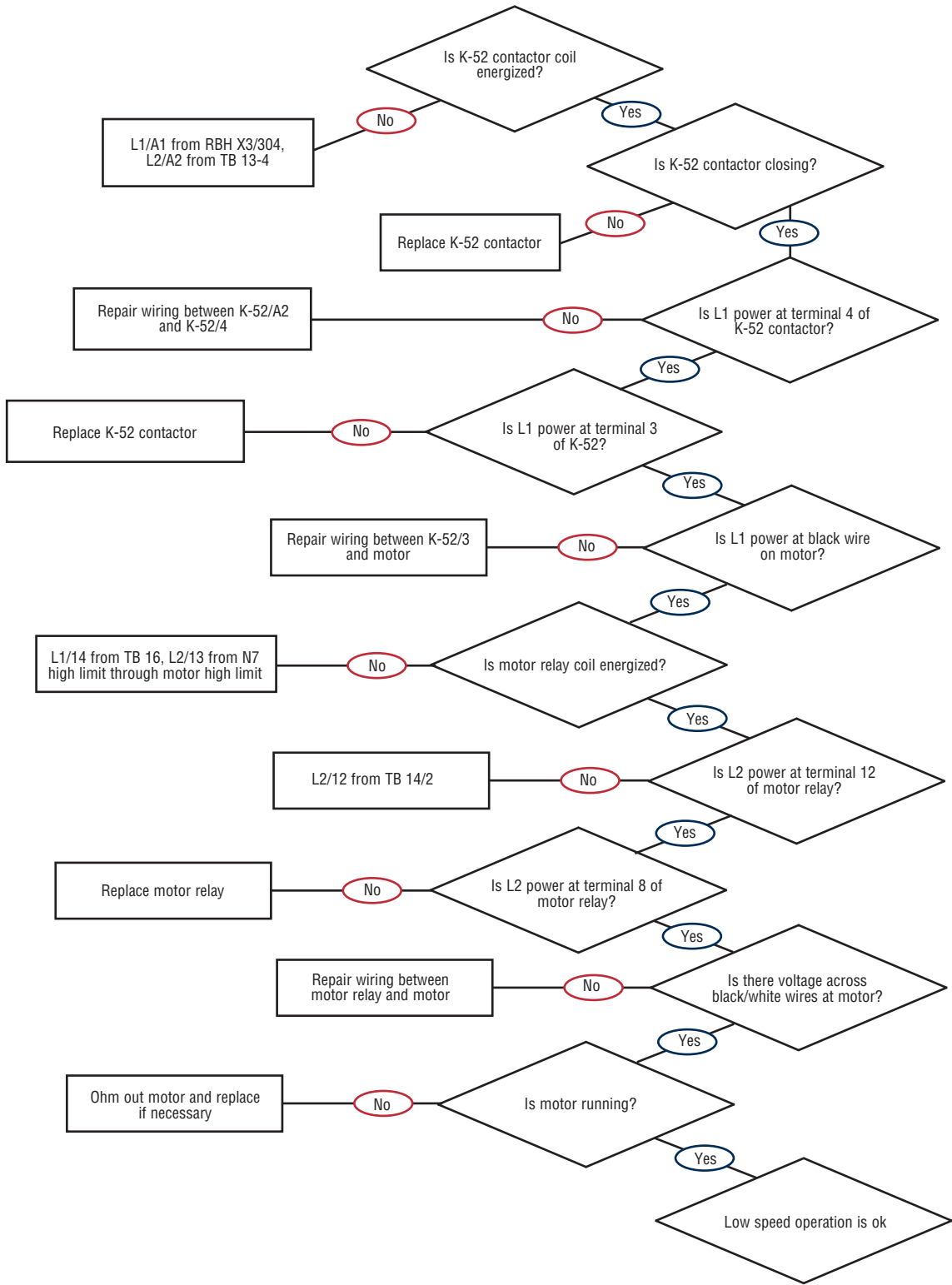

TROUBLESHOOTING TREES

Single Speed Motor - No Motor Operation (with motor protection switch)

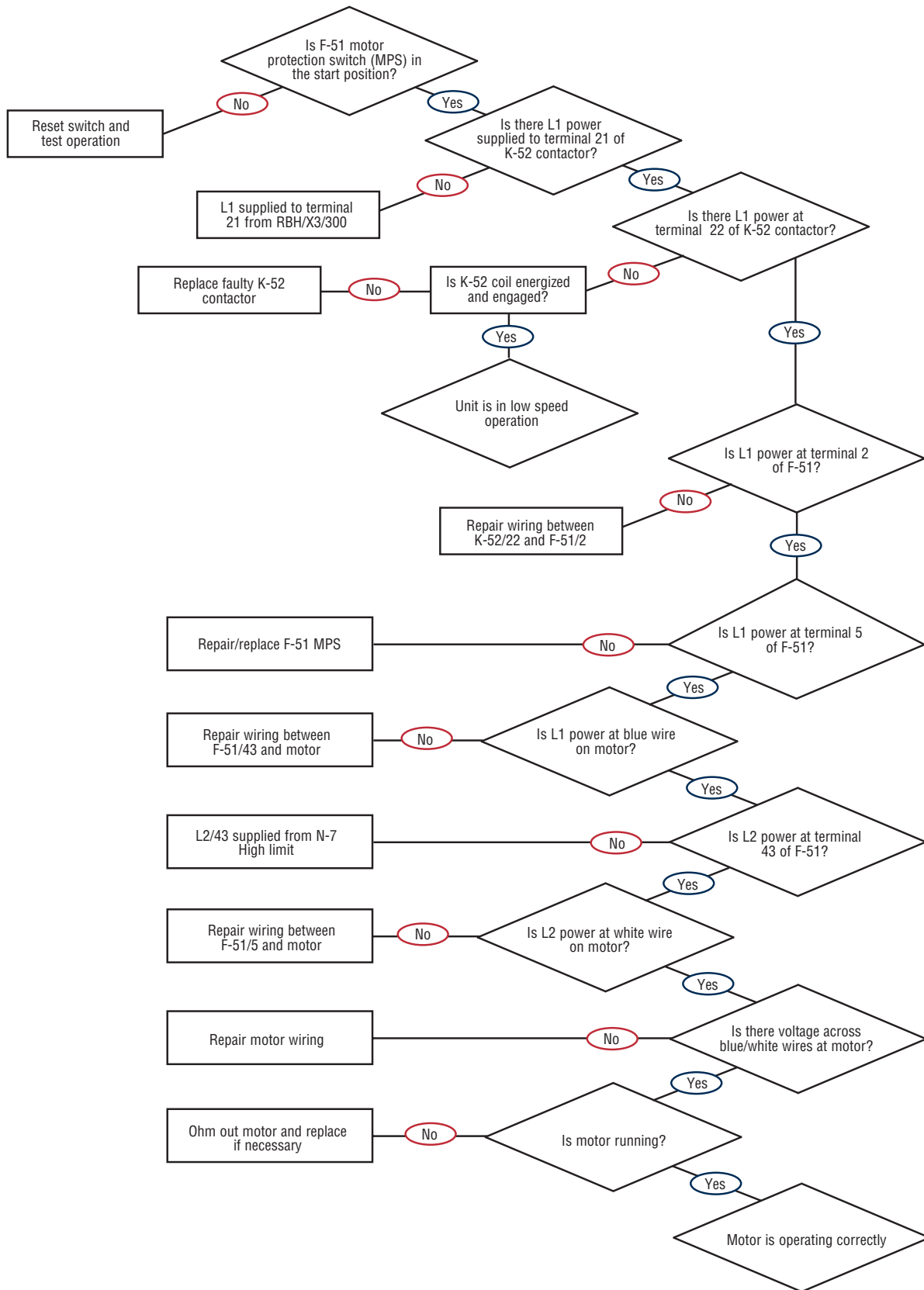

TROUBLESHOOTING TREES

Single Speed Motor - No Motor Operation (without motor protection switch)

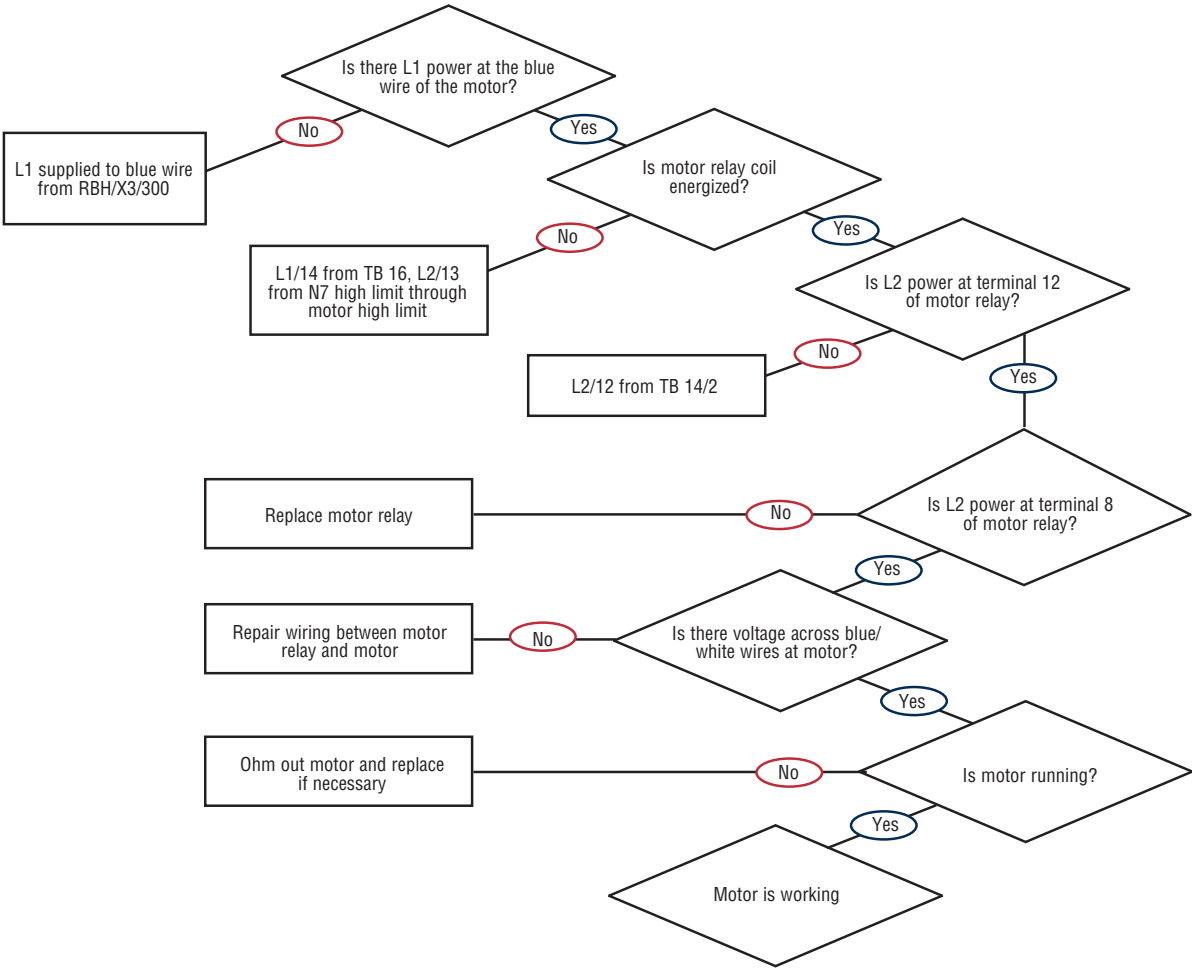

TROUBLESHOOTING TREES

No Display/Control not powering on (Unit Dead)

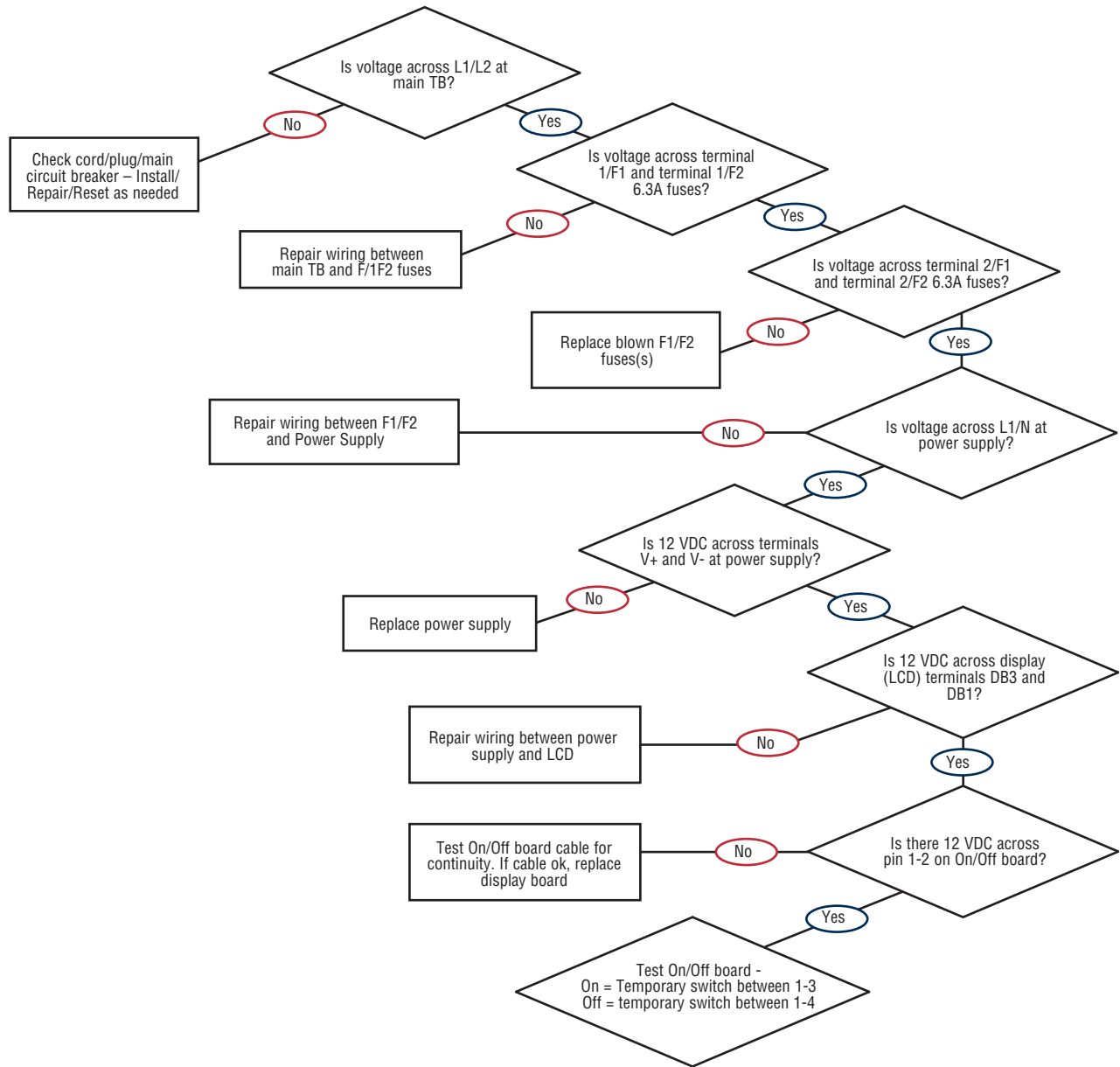

TROUBLESHOOTING TREES

No Display/No Operation - Simple Control

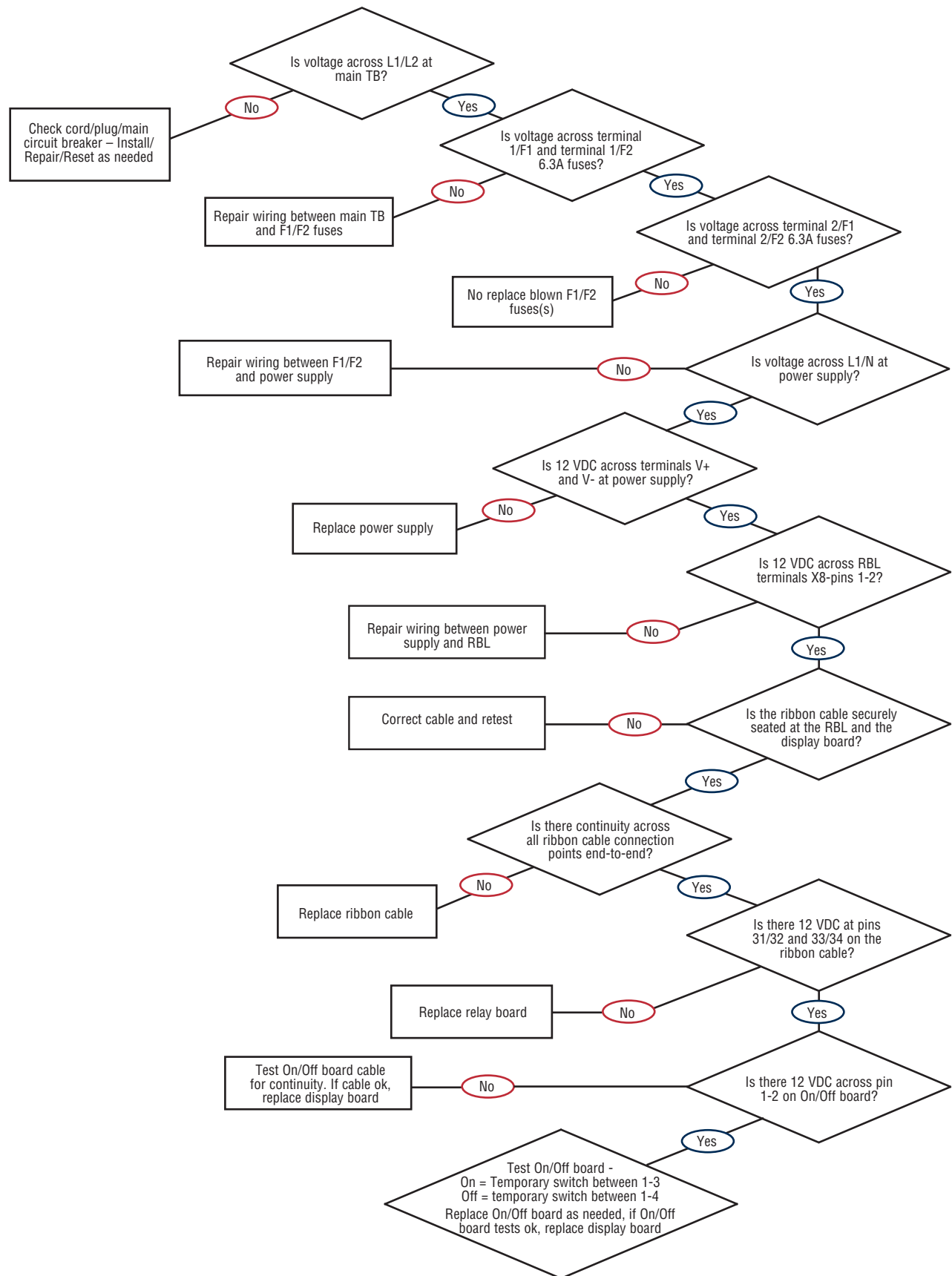

TROUBLESHOOTING TREES

No Browning Vent Motor Operation

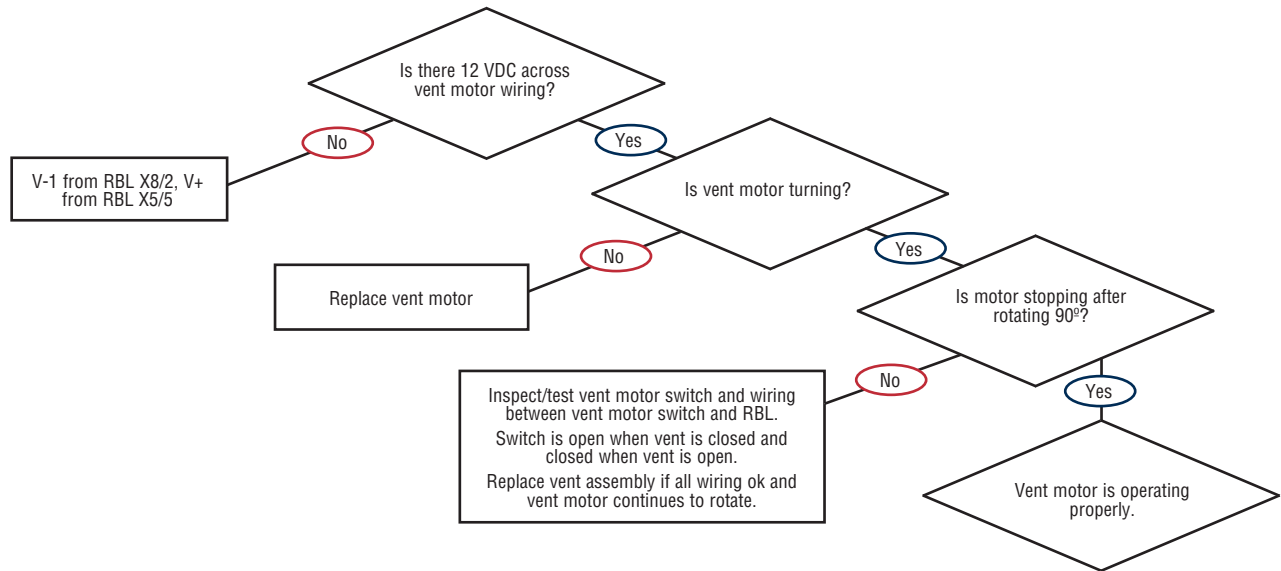

TROUBLESHOOTING TREES

No Oven Lamp

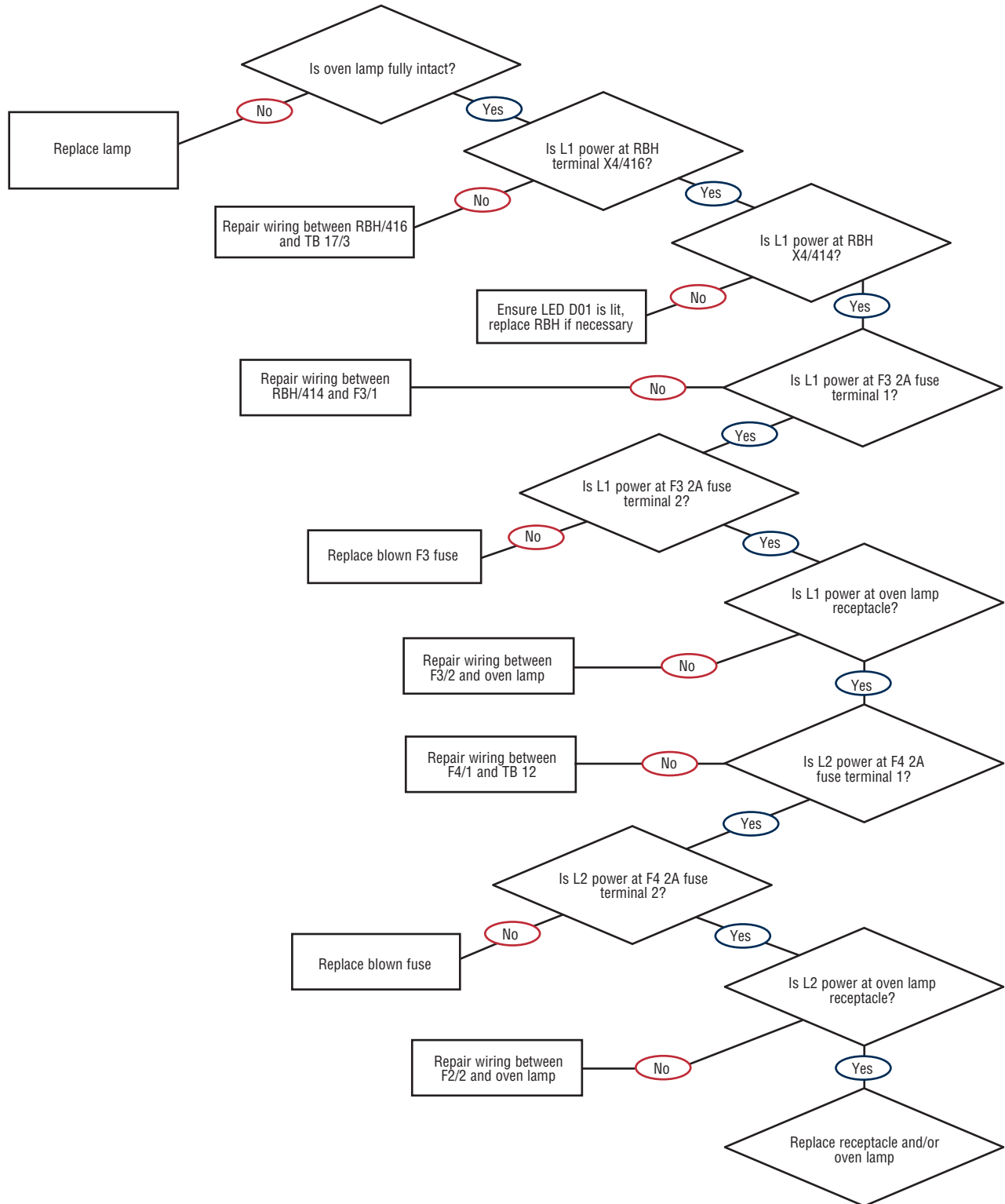

TROUBLESHOOTING TREES

No Condensate Injection (E15 error code)

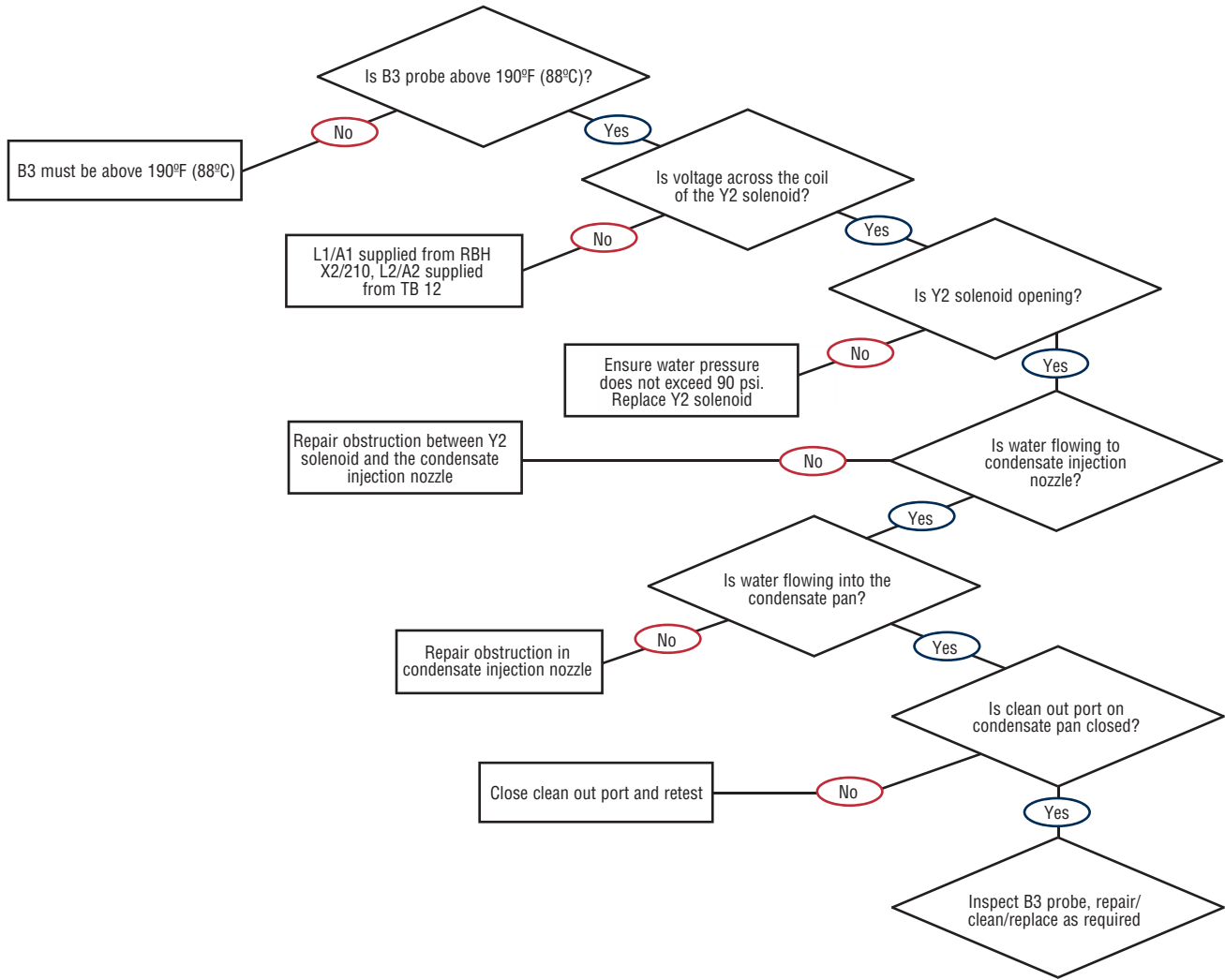

TROUBLESHOOTING TREES

No Cleaning Operation

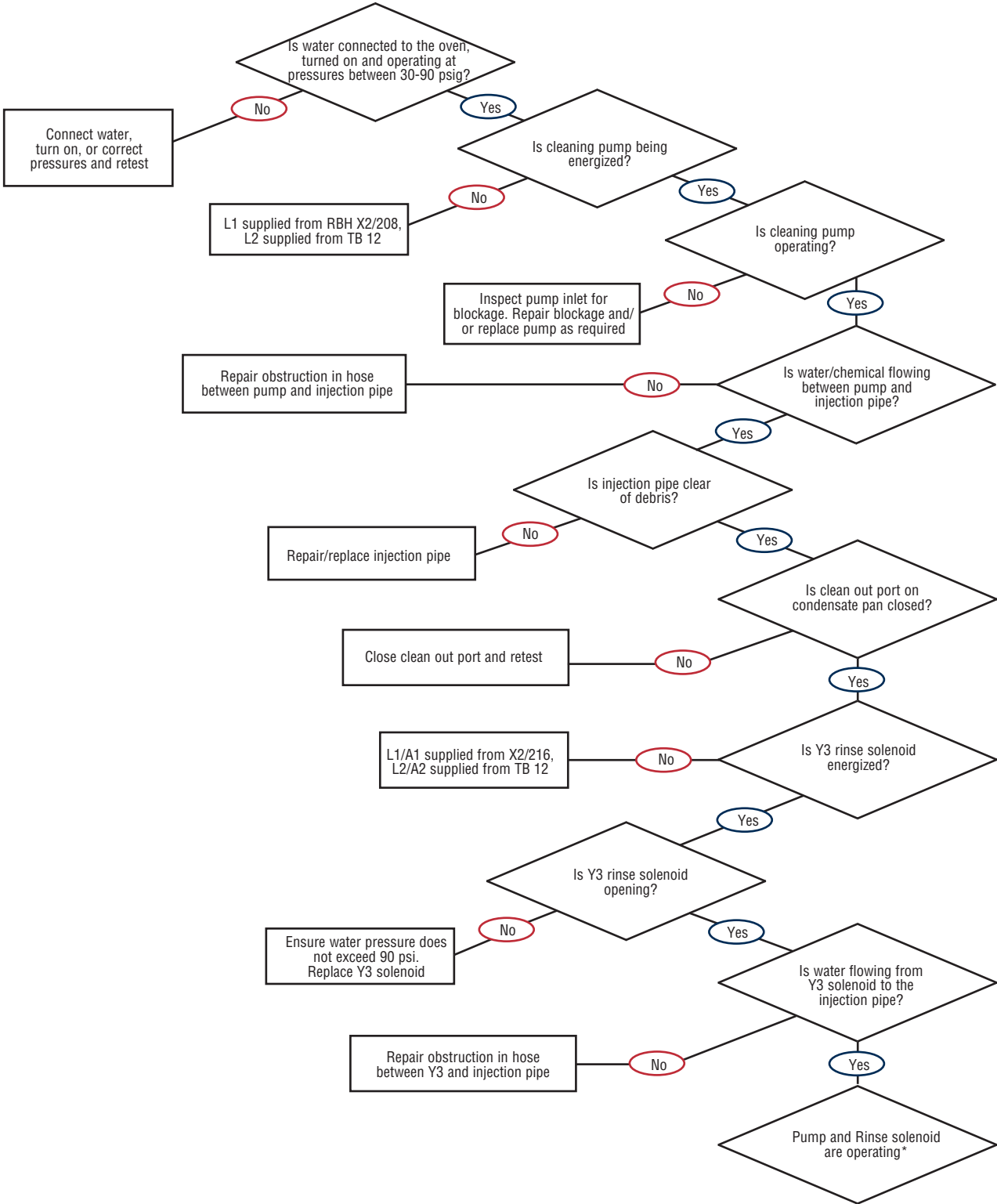

*Refer to operation/care manual for best practices regarding cleaning procedures

TROUBLESHOOTING TREES

No Cooling Fan Operation

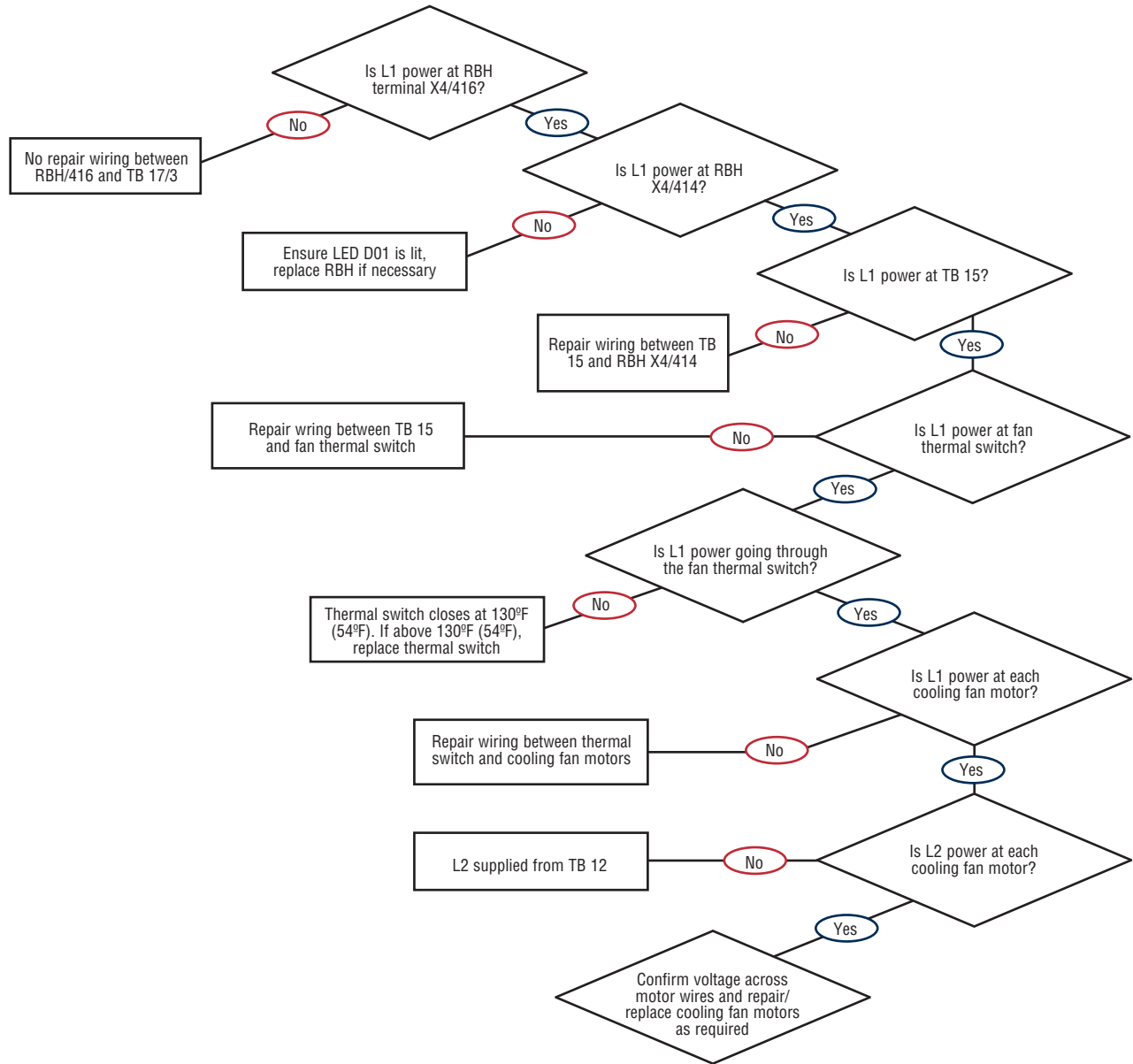

TROUBLESHOOTING TREES

No Hood Operation

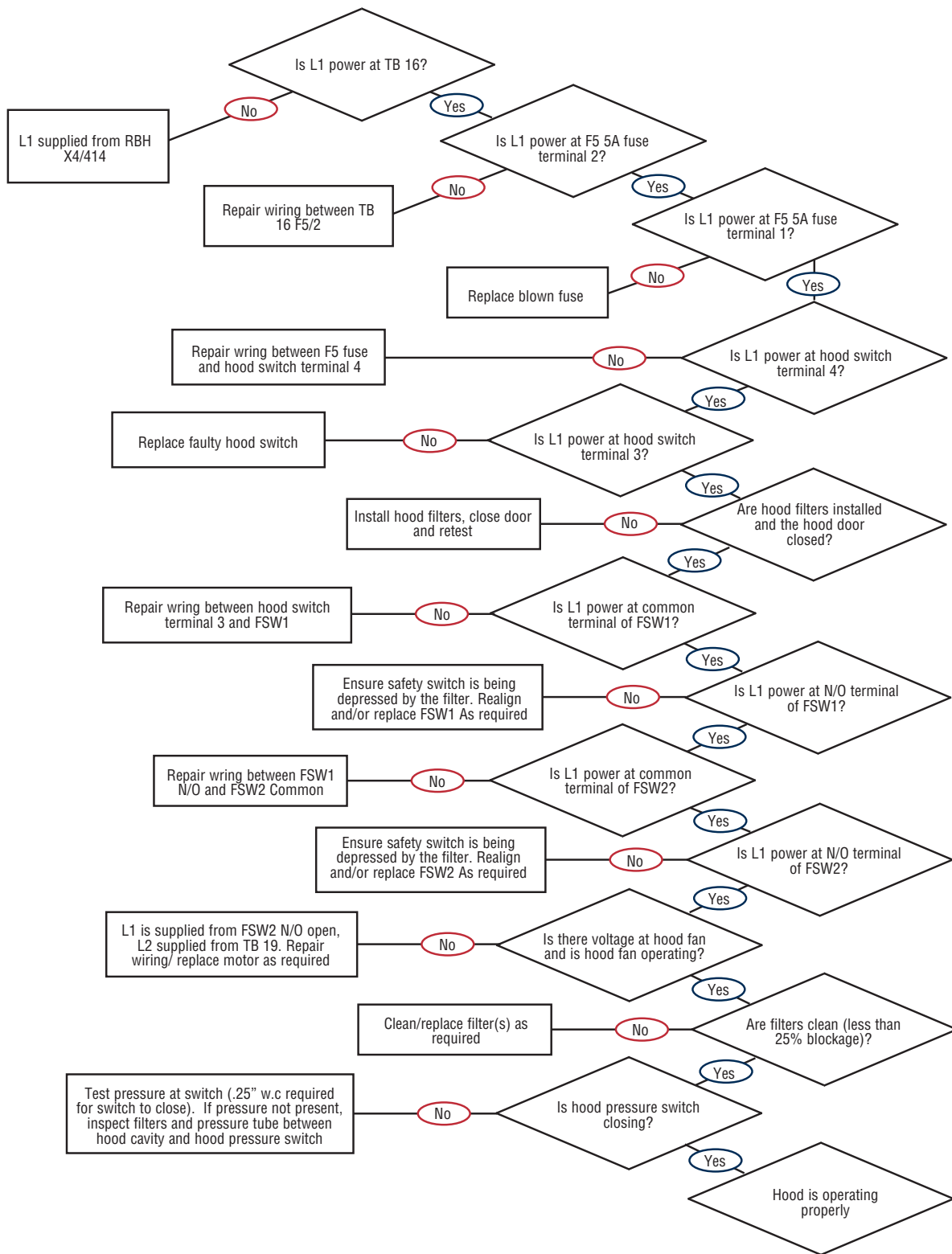

TROUBLESHOOTING TREES

Hood Door Safety Latch Not Closing

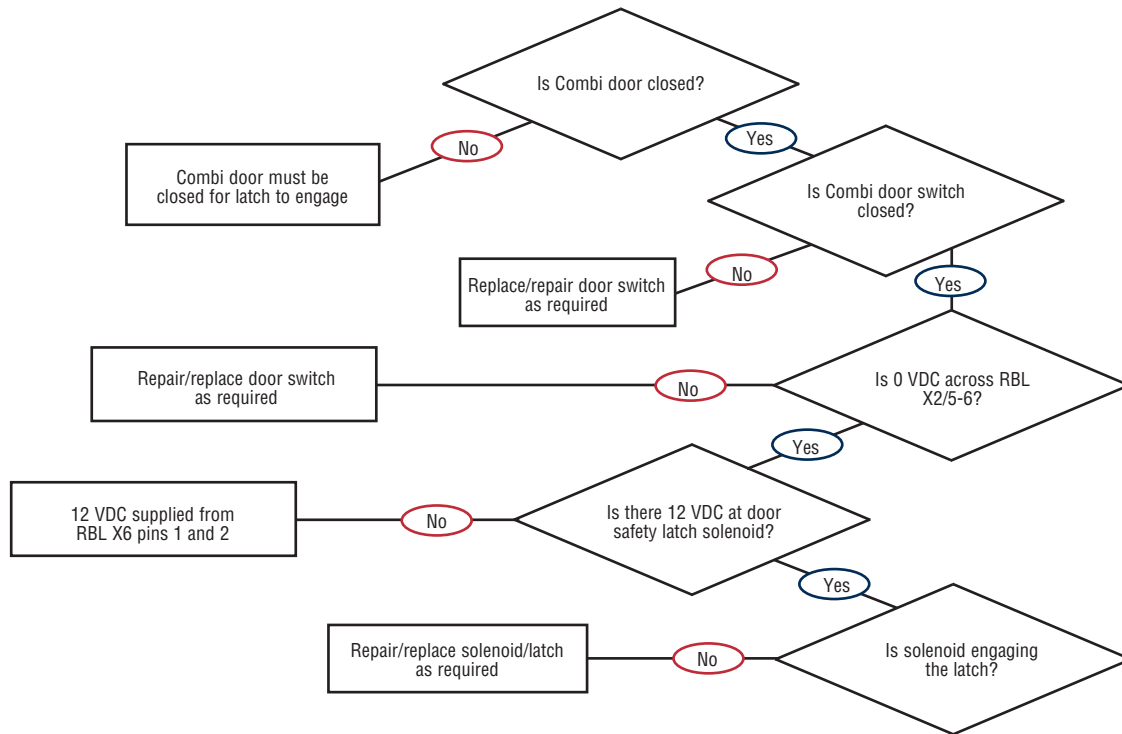

TROUBLESHOOTING TREES

Hood Door Safety Latch Not Releasing

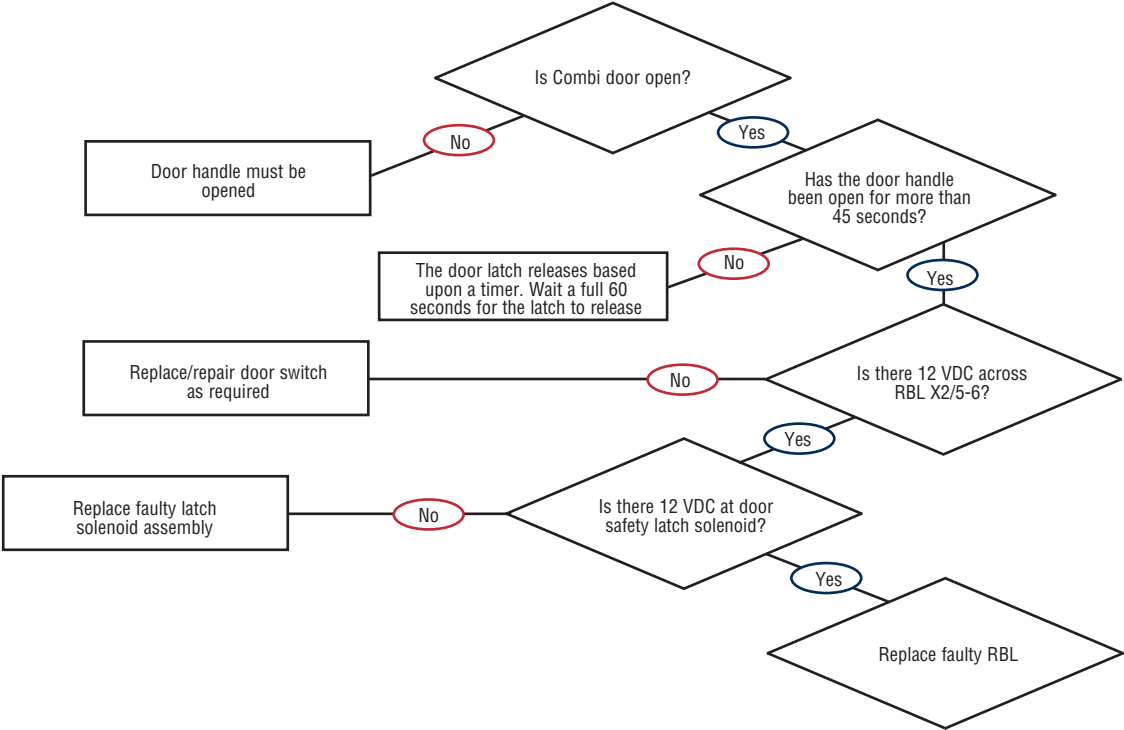

TROUBLESHOOTING TREES

No Browning Bar Heat (208-240V, 3PH)

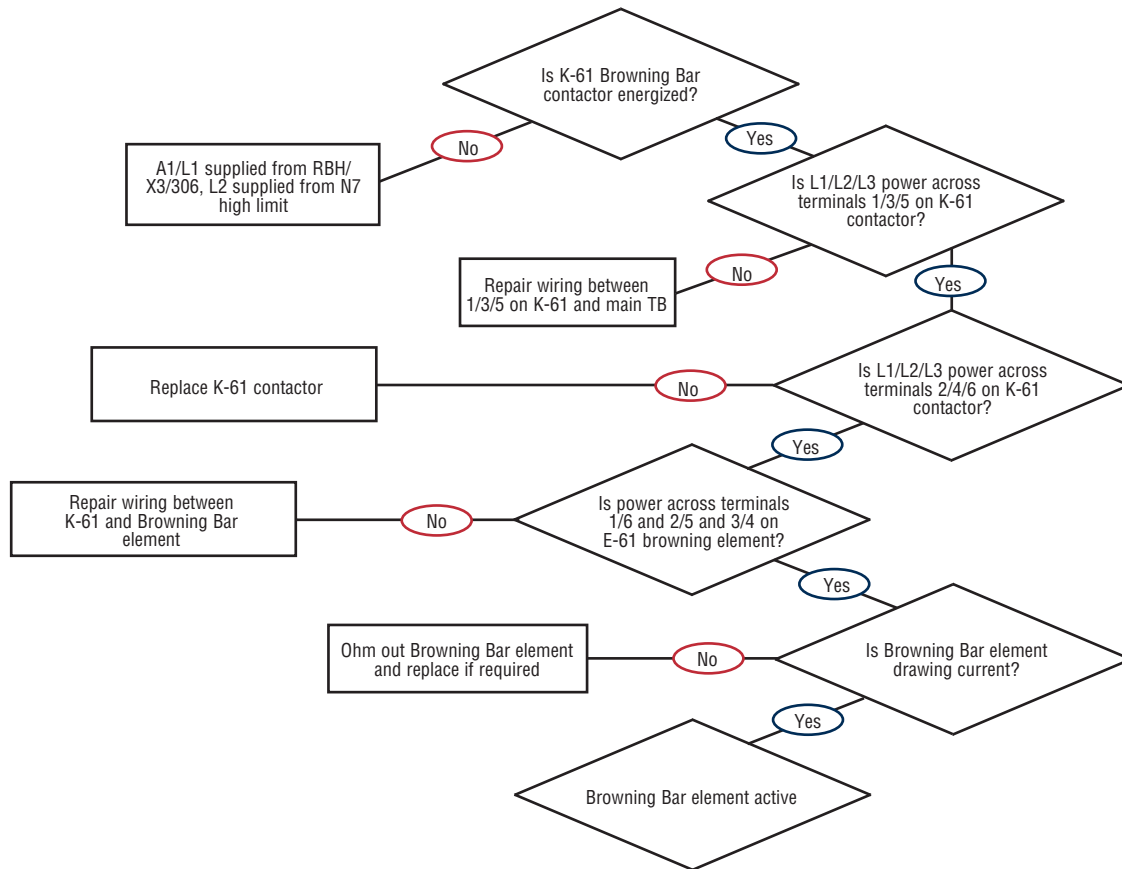

TROUBLESHOOTING TREES

No Browning Bar Heat (380-415V, 3PH)

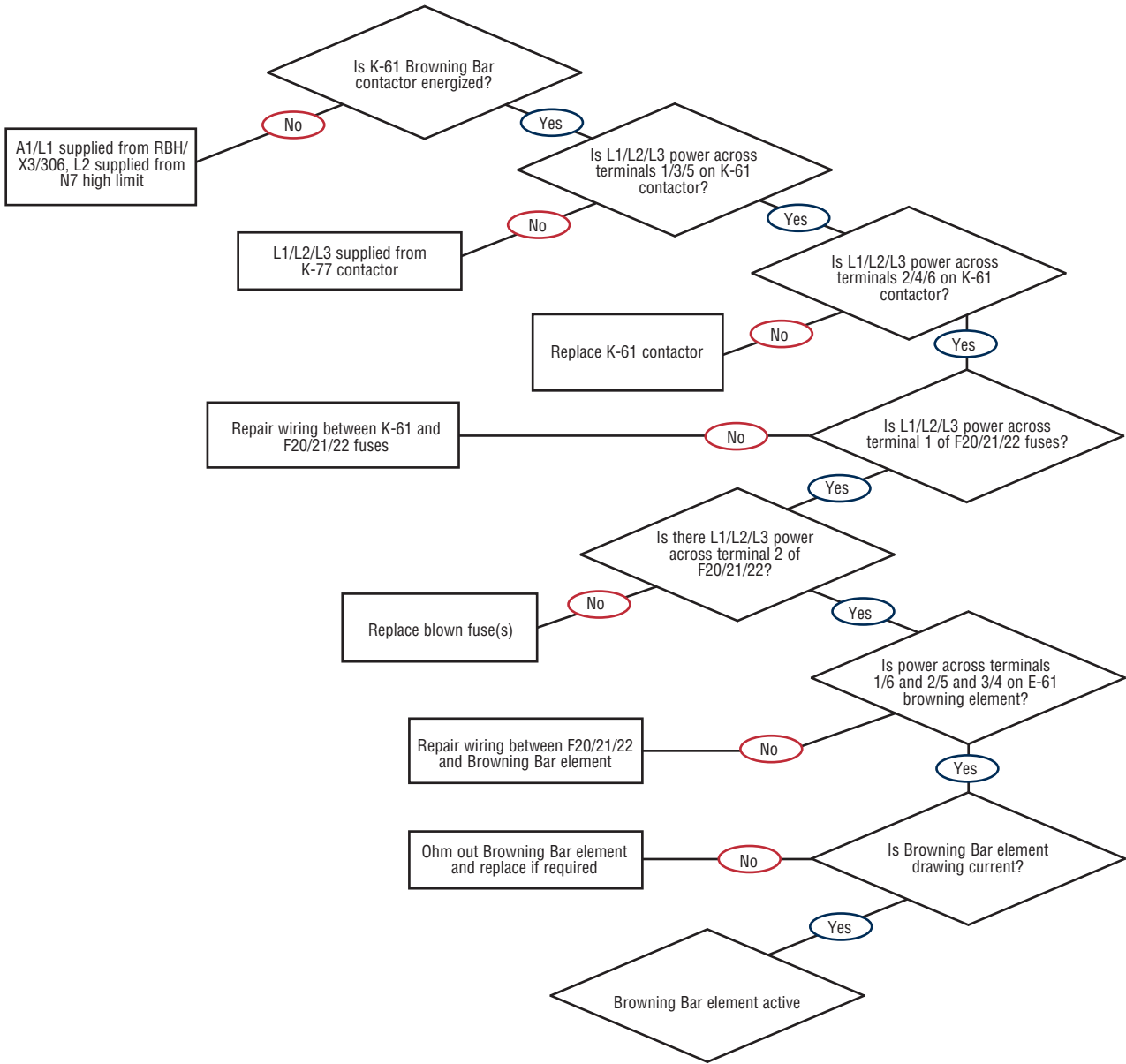

TROUBLESHOOTING TREES

K-77 Safety Contactor Troubleshooting (380-415V only)

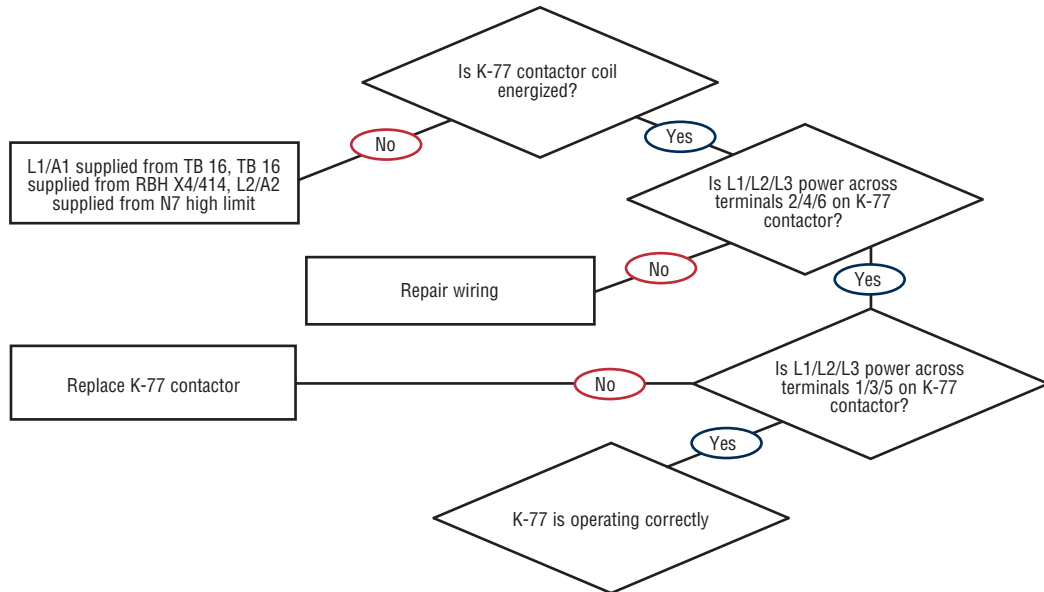

PARTS INFORMATION

SERVICE PARTS

Exterior	E-2
Rear and Bottom Service Parts	E-3
Painted Panels	E-4
Right Hand Door Assembly	E-6
Left Hand Door Assembly	E-7
Field Retrofit Kit: Bumper With Threads	E-8
Interior View	E-9
Top Interior and Right Side	E-10
Interior Rear (Before 07/15)	E-11
Interior Rear (After 07/15)	E-12
Directional Panel Assembly	E-13
Combitherm Motor	E-14
Electrical Cord & Routing	E-15
Plumbing	E-16
Control Assembly - Simple (Before 09/14)	E-18
Control Assembly - Simple (After 09/14)	E-19
Control Assembly - Express Touch (Before 02/15)	E-20
Control Assembly - Express Touch (After 02/15)	E-21
Touch Control Replacement Kit (Before 02/15)	E-22
Touch Control Replacement Kit (After 02/15)	E-23
Touch Control Conversion Kit	E-24
Catalytic Converter	E-25
Broiling Element	E-26
Condenser Tank	E-27
Lamp Assembly	E-28
Smoker Chip Tray Assembly	E-29
Optional Single Point Probe Assembly	E-30
Optional Hand Shower Assembly	E-31
Electrical Assembly	E-32
Ventless Hood Assembly	E-40
Return to Main Table of Contents	ii

PARTS INFORMATION

EXTERIOR VIEW

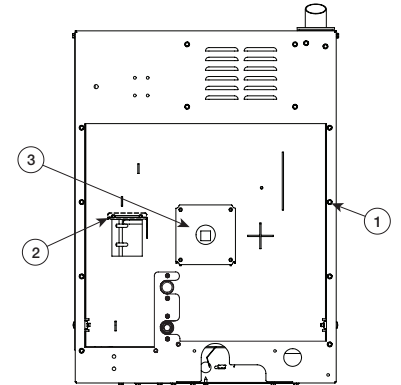
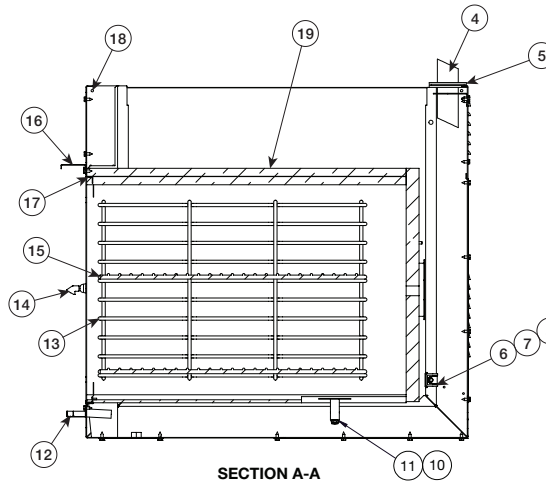
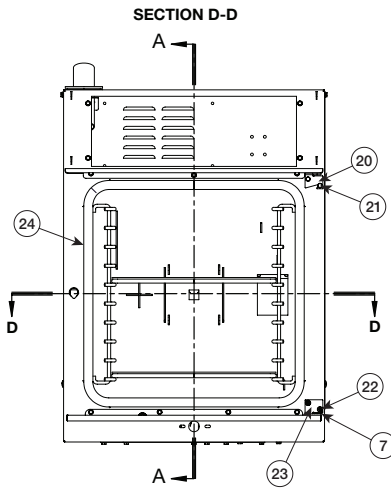
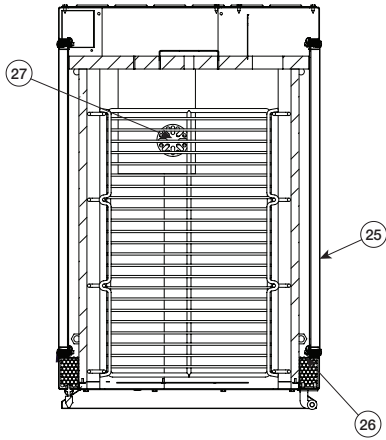

Item	Part	Description	Qty.
1	SC-29871	Screw, #8 x 1/2" Hex Flg	47
2	1012981	Cover, Element Splash	1
3	1012382	Bracket, Motor Mount	1
4	5014726	Weld Assembly, Vent Tube	1
5	BU-28391	Bushing, Socket, Membrane	1
6	CL-22196	Clip, Holding, M6	4
7	ST-22193	Stud, M6 x 27mm, 1/4 Turn	4
8	SD-22194	Spring, M6 x 48, Safety	4
9	WS-22195	Washer, Safety, Steel	4
10	WS-22302	Washer, Split Lock	1
11	NU-22292	Nut, M8-1.25, Hex, 18-8, Din #934	1
12	5014033	Drip Tray, Weld Assembly	1
13	SR-29602	Side Rack, Wire, S/S	2
14	LT-29636	Latch, Door, Dog	1
15	SH-2903	Shelf	2
16	1012798	Deflector Strip	1

Item	Part	Description	Qty.
17	1012295	Bracket, Gasket Corner Channel	1
18	SC-22281	Screw, M5 x 0.81 x 16mm Flat	3
19	5015470	Insulation Kit	1
20	1012300	Plate, Hinge Door, Upper, RH	1
	1012301	Plate, Hinge Door, Upper, LH	1
21	SC-22926	Screw, M5 x 0.8 x 16mm, Hex	3
22	SC-22281	Screw, M5 x 0.8 x 16mm Flat	2
23	1012822	Plate, Hinge Door, Lower, LH	1
	1012821	Plate, Hinge Door, Lower, RH	1
24	5014123	Gasket, Door	1
25	1012268	Panel, Side Access, S/S	2
	1013024	Panel, Side Access, Painted (specify color)	2
26	1012637	Bracket, Air Tunnel	1
27	DA-2943	Drain Screen Assembly	1
28*	WS-29885	Washer, Nylon, For 5/16"	1

PARTS INFORMATION

REAR & BOTTOM SERVICE PARTS

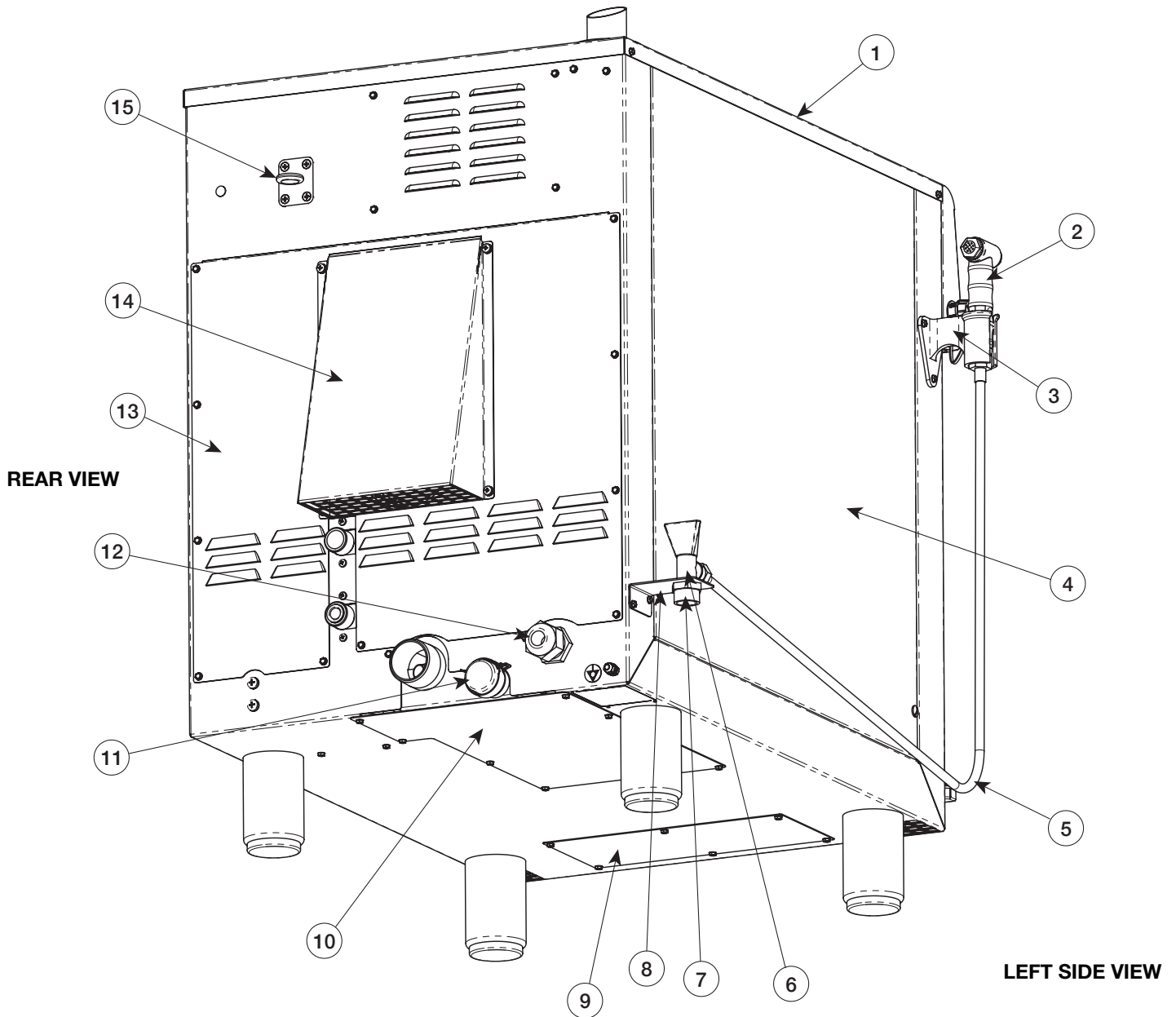

Item	Part	Description	Qty.
1	1012266	Panel, Top Access, S/S**	1
	PB-29664	Plumbing, Hand Sprayer	
3	HL-29741	Holder, Hand Sprayer	1
4	1012268	Panel, Side Access, S/S**	1
5	HO-29669	Hose, Hand Sprayer	1
6	VA-29646	Valve, Hand Sprayer Shut-off	1
7	PB-35228	Plumbing, 3/4" GHT (M) to 1/2" NPT (F)	1
8	1012645	Bracket, Mount Shut-off Valve	1

Item	Part	Description	Qty.
9	1013370	Panel, Bottom Access	1
10	1013359	Cover, Condenser Tank	1
11	CP-29648	Cap, Push-on, Fits 1-1/4" OD	1
12	BU-34977	Cable Gland, M32, Black	1
13	5017990	Back Panel with Inserts	1
14	1015490	Air Vent	1
15	BT-26884	Tether bracket (not standard on all models)	1

** See following page for painted panel part numbers

PARTS INFORMATION

PAINTED PANELS

Item	Description	Color	Part Number
A	Panel, Cover, Sensor	Black	PE-35548
		Brown	PE-35552
		Burgundy	PE-35549
		Custom	PE-35553
		Red	PE-35550
	White	PE-35551	
B	Panel, Enclosure, Base	Black	PE-35536
		Custom	PE-35541
		Brown	PE-35540
		Burgundy	PE-35537
		Red	PE-35538
	White	PE-35539	
C	Panel, Enclosure, Top	Black	PE-38009
		Brown	PE-38013
		Burgundy	PE-38010
		Custom	PE-38014
		Red	PE-38011
	White	PE-38012	
D	Panel, Side Access	Black	PE-35524
		Brown	PE-35528
		Burgundy	PE-35525
		Custom	PE-35529
		Red	PE-35526
	White	PE-35527	
E	Panel, Spot, Control, Simple	Black	PE-35584
		Brown	PE-35588
		Burgundy	PE-35585
		Custom	PE-35589
		Red	PE-35586
	White	PE-35587	
F	Panel, Spot, Control, Touch, LH	Black	PE-35590
		Brown	PE-35594
		Burgundy	PE-35591
		Custom	PE-35595
		Red	PE-35592
	White	PE-35593	
G	Panel, Spot, Control, Touch, , RH	Black	PE-35554
		Brown	PE-35558
		Burgundy	PE-35555
		Custom	PE-35559
		Red	PE-35556
	White	PE-35635	
H	Panel, Spot, Cover, Access	Black	PE-35632
		Brown	PE-35636
		Burgundy	PE-35633
		Custom	PE-35637
		Red	PE-35634
	White	PE-35635	
I	Panel, Spot, Enclosure	Black	PE-35626
		Brown	PE-35630
		Burgundy	PE-35627
		Custom	PE-35631
		Red	PE-35628
	White	PE-35629	

Item	Panel Color	Part Number
J	Panel, Spot, Hndl Mnt, LH Door	Black PE-35602
	Brown	PE-35606
	Burgundy	PE-35603
	Custom	PE-35607
	Red	PE-35604
	White	PE-35605
K	Panel, Spot, Hndl Mnt, RH Door	Black PE-35596
	Brown	PE-35600
	Burgundy	PE-35597
	Custom	PE-35601
	Red	PE-35598
	White	PE-35599
L	Panel, Spot/Weld, Touch Control, LH	Black PE-35614
	Brown	PE-35618
	Burgundy	PE-35615
	Custom	PE-35619
	Red	PE-35616
	White	PE-35617
M	Panel, Spot/Weld, Touch Control, RH	Black PE-35608
	Brown	PE-35612
	Burgundy	PE-35609
	Custom	PE-35613
	Red	PE-35610
	White	PE-35611
N	Panel, Top Access	Black PE-35530
	Brown	PE-35534
	Burgundy	PE-35531
	Custom	PE-35535
	Red	PE-35532
	White	PE-35533
O	Panel, Weld, Door, LH	Black PE-35578
	Brown	PE-35582
	Burgundy	PE-35579
	Custom	PE-35583
	Red	PE-35580
	White	PE-35581
P	Panel, Weld, Door, RH	Black PE-35572
	Brown	PE-35576
	Burgundy	PE-35573
	Custom	PE-35577
	Red	PE-35574
	White	PE-35575
Q	Panel, Weld, Outer Shell, LH	Black PRIOR TO 7/1/15 PE-35566
	Black AFTER 7/1/15	PE-37447
	Brown PRIOR TO 7/1/15	PE-35570
	Brown AFTER 7/1/15	PE-37451
	Burgundy PRIOR TO 7/1/15	PE-35567
	Burgundy AFTER 7/1/15	PE-37448
	Custom PRIOR TO 7/1/15	PE-35571
	Custom AFTER 7/1/15	PE-37452
	Red PRIOR TO 7/1/15	PE-35568
	Red AFTER 7/1/15	PE-37449
White PRIOR TO 7/1/15	PE-35569	
White AFTER 7/1/15	PE-37450	

CONTINUED ON THE NEXT PAGE

PARTS INFORMATION

PAINTED PANELS CONTINUED

Item	Panel Color	Part Number
R	Panel, Weld, Outer Shell, RH	Black PRIOR TO 7/1/15
		Black AFTER 7/1/15
		Brown PRIOR TO 7/1/15
		Brown AFTER 7/1/15
		Burgundy PRIOR TO 7/1/15
		Burgundy AFTER 7/1/15
		Custom PRIOR TO 7/1/15
		Custom AFTER 7/1/15
		Red PRIOR TO 7/1/15
		Red AFTER 7/1/15
		White PRIOR TO 7/1/15
		White AFTER 7/1/15

Item	Panel Color	Part Number
S	Panel, Weld/Spot, Door, LH	Black
		Brown
		Burgundy
		Custom
		Red
		White
T	Panel, Weld/Spot, Door, RH	Black
		Brown
		Burgundy
		Custom
		Red
		White

PARTS INFORMATION

RIGHT HAND DOOR ASSEMBLY

Item	Description	Part Number
A	Weld Assembly, Right Hand Door	Black 5015467
		Brown 5015759
		Burgundy 5015468
		Custom 5015469
		Red 5015757
		White 5015758

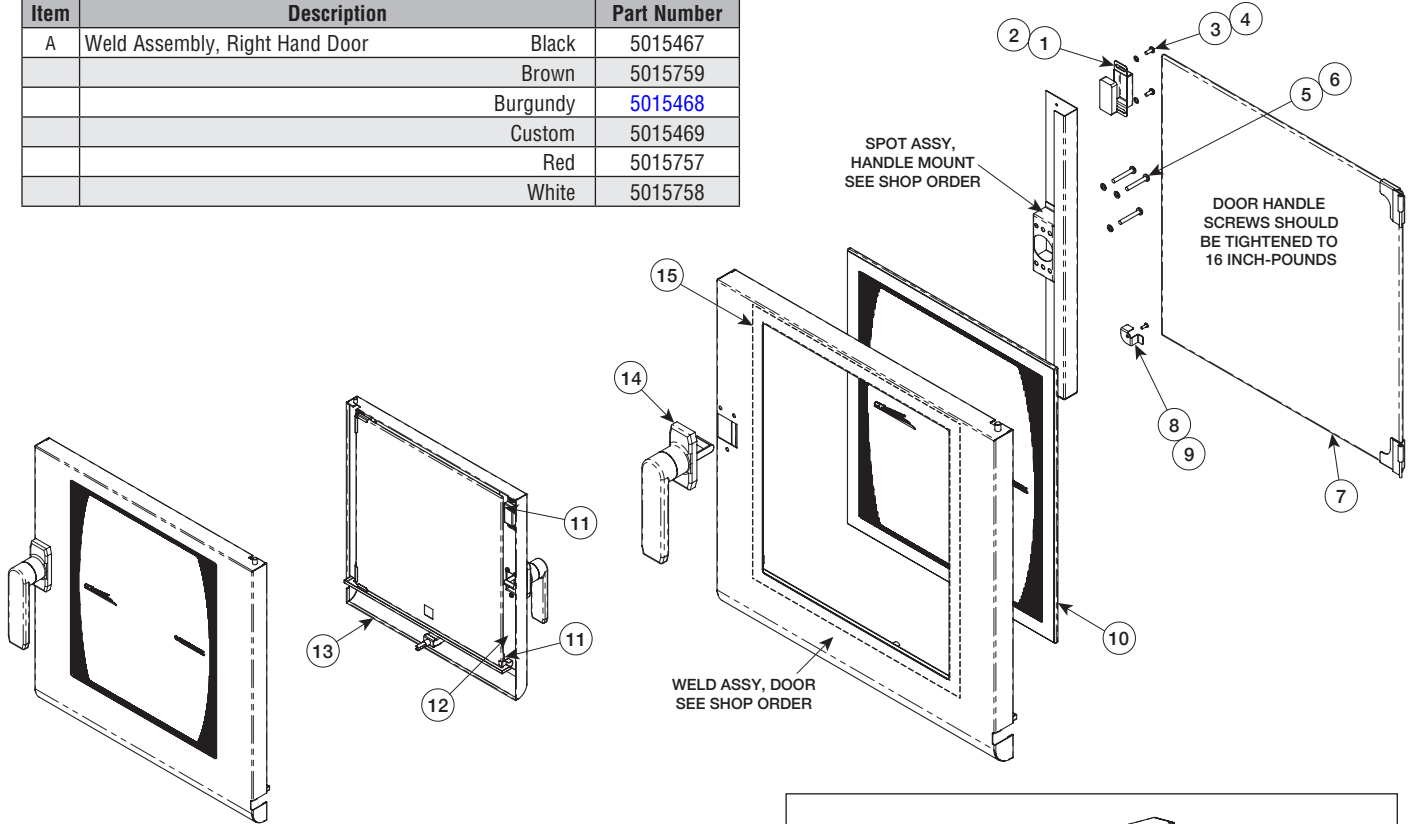

Right Hand Door Assembly - 5015466

Item	Part	Description	Qty.
1	1007698	Cover, Door Magnet, Single	1
2	MA-25734	Magnet, Door, AR-7E, Black	1
3	SC-22273	Screw, M4 x 0.7mm Pan	3
4	WS-22300	Washer, M4 Split Lock	3
5	SC-29735	Screw, M5 x 0.8 x 35mm Pan	3
6	WS-22301	Washer, M5 Split Lock S/S 18-8	3
7	5013647	Assembly, Inner Glass Right Hand Door	1
8	1012299	Clip, Inner Glass Right Hand Door	1
9	RI-27108	Rivet, Sealed	1
10	GL-29868	Glass, Outer, Door	1
11	SP-36060	Spacer, Inner Glass Table Top	2
12	5014392	Spot, Assembly, Handle Mount S/S	1
13	5015462	Spot Assembly, Door Right Hand S/S	1
14	HD-29635	Handle, Door, Pendulum	1
15	TA-25125	Tape, Duplont 5'	1
16	5015005	Assembly, Latch	1

*NOT SHOWN

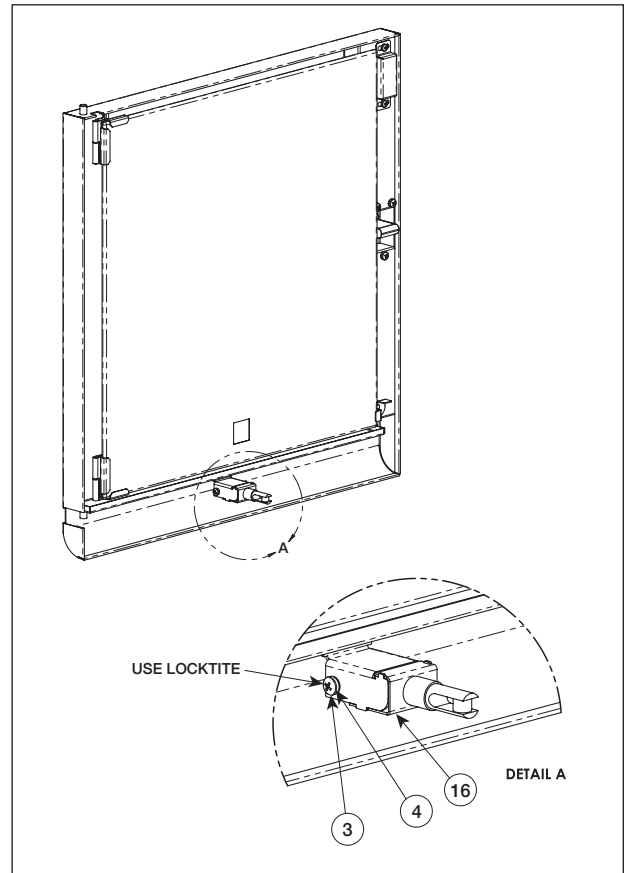

Right Hand Door Assembly with Ventless Hood - 5015466

PARTS INFORMATION

LEFT HAND DOOR ASSEMBLY

Item	Description	Part Number
A	Weld Assembly, Right Hand Door	Black 5014749
		Brown 5015744
		Burgundy 5014800
		Custom 5014801
		Red 5015742
		White 5015743

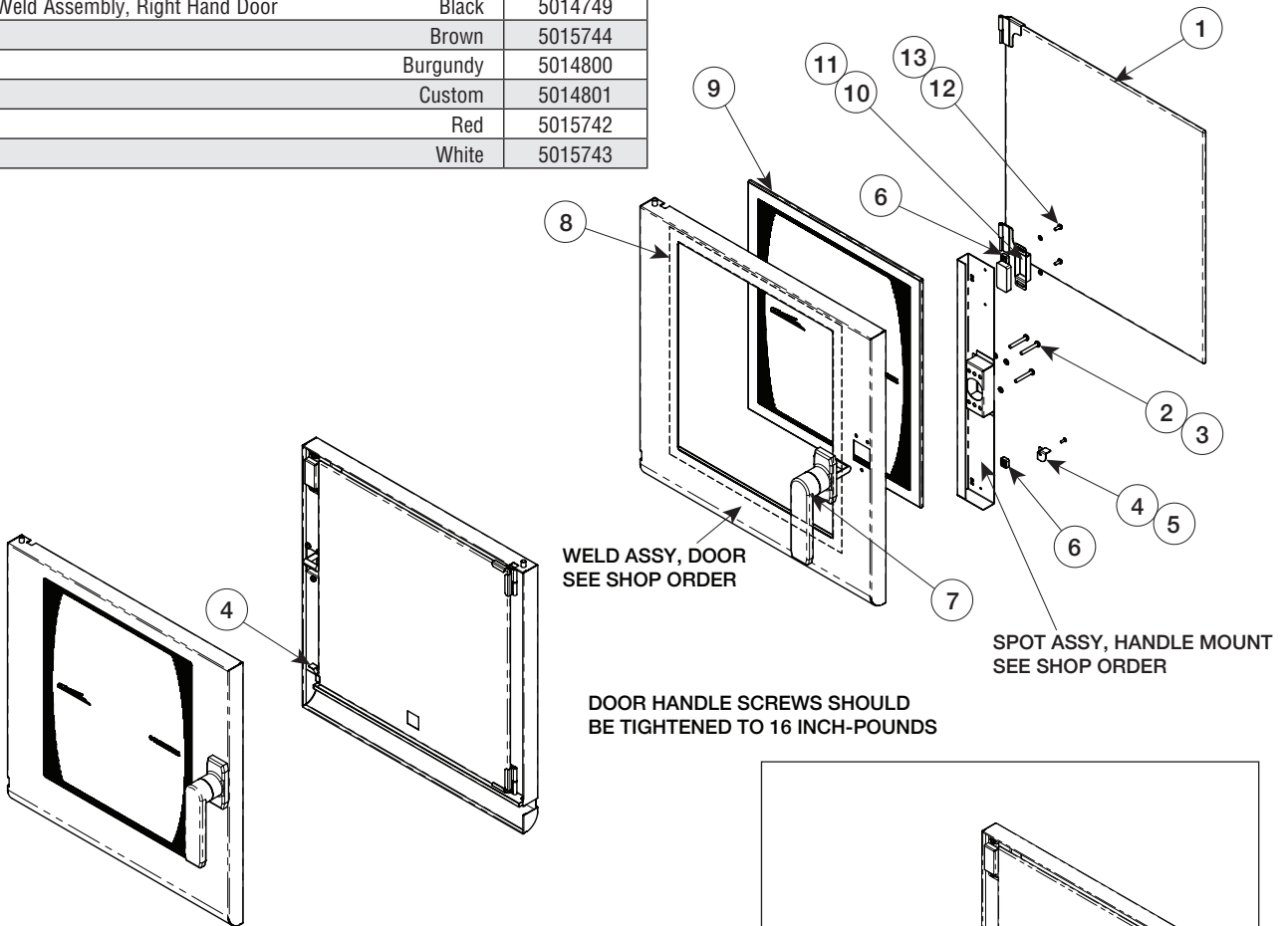

Left Hand Door Assembly - **5014748**

Item	Part	Description	Qty.
1	5014828	Assembly, Inner Glass Left Hand Door	1
2	SC-29735	Screw, M5 x 0.8 x 35mm Pan	3
3	WS-22301	Washer, M5 Split Lock S/S 18-8	3
4	1013174	Clip, Inner Glass Left Hand Door	1
5	RI-27108	Rivet, Sealed	1
6	SP-36060	Spacer, Inner Glass Table Top	2
7	HD-29635	Handle, Door, Pendulum	1
8	TA-25125	Tape, Duplont 5'	1
9	GL-29868	Glass, Outer, Door	1
10	1007698	Cover, Door Magnet, Single	1
11	MA-25734	Magnet, Door, AR-7E, Black	1
12	SC-22273	Screw, M4 x 0.7 x 10mm Pan	2
13	WS-22300	Washer, Split Lock	2
14	5015005	Assembly, Latch	1

*NOT SHOWN

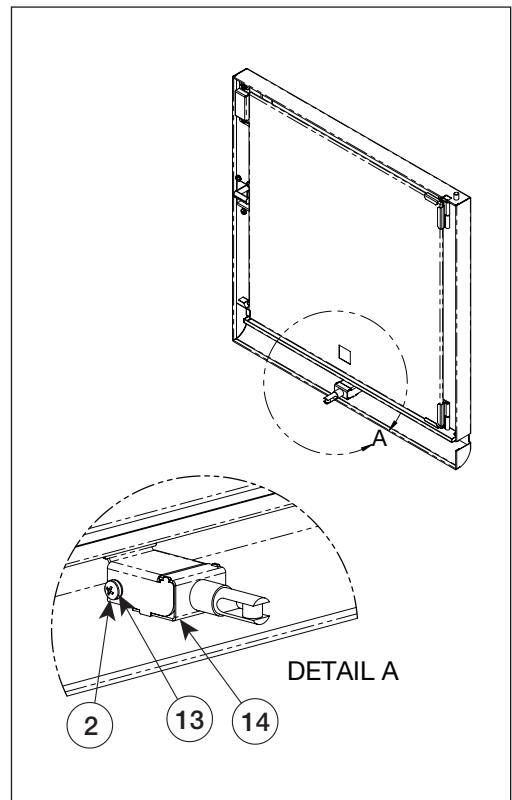

Left Hand Door Assembly
with Ventless Hood - **5015584**

PARTS INFORMATION

FIELD RETROFIT KIT: BUMPER WITH THREADS

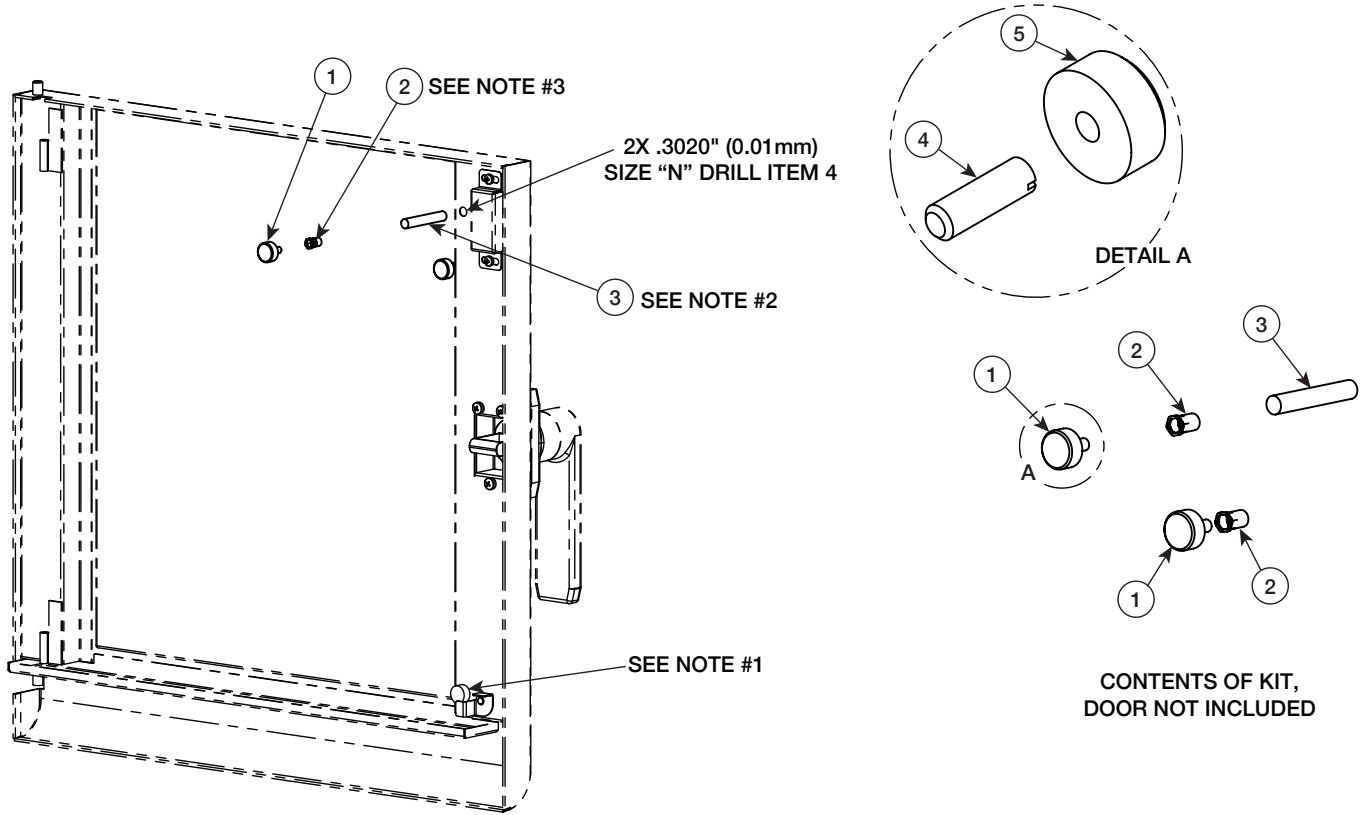

RETROFIT KIT INSTRUCTIONS:

1. REMOVE OLD BUMPER AND CLEAN SURFACES.
2. DRILL OUT TWO HOLES (SIZE N: 0.3020") WITH DRILL BIT PROVIDED.
3. USE INSERT GUN TO CRIMP TWO INSERT NUTS (NU-23909).
4. INSTALL BUMPER WITH THREADS (5018362), 2 PLACES.

Item	Part	Description	Qty.
1	5018362	Bumper With Threads	2
2	NU-23909	Nut, Hex Insert M5	2
3	68566	Drill Bit, Size N	1
4	SC-25091	Screw, M5 x 0.8 x 16mm SSCR	1
5	BM-37115	Bumper Stop, Inner Door	1

PARTS INFORMATION

INTERIOR VIEW

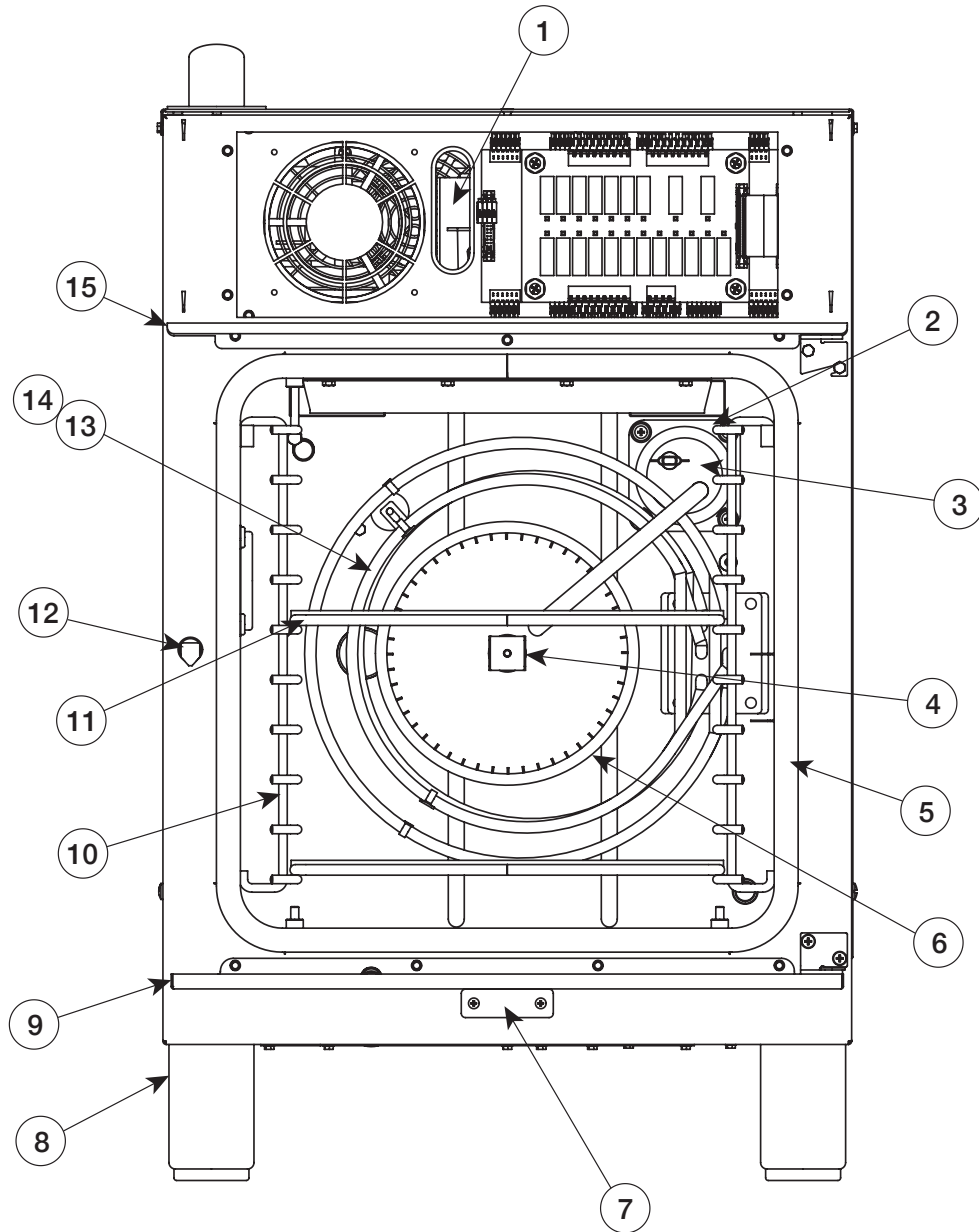

Item	Part	Description	Qty.	Item	Part	Description	Qty.
1	CB-34033	Cable, 20" (510mm) long	1	10	SR-29602	Side Rack, Wire, S/S	1
2	CV-23896	Cover, S/S Ring	1	11	SH-2903	Shelf, S/S	1
3	5016140	Injection Tube, with Cleaning	1	12	LT-29636	Latch, Door	1
	5016205	Injection Tube, without Cleaning	1	13	EL-29560	Element, Convection, 2 Coil, 1Ph	1
	SA-23934	Injection Tube Seal	1		EL-29649	Element, Convection, 3 Coil, 3Ph	1
4	1013034	Bracket	1	14	GS-29818	Seal, Convection Element	1
5	5014123	Gasket, Door	1	15	1012798	Deflector Strip	1
6	WH-29634	Fan Wheel, 197mm OD	1	16*	EL-35057	Broiling Element, 208-240V	1
7	1013935	Cover Plate	1		EL-36032	Broiling Element, 318-480V	1
8	LG-29644	Legs, 4" Bullet	4	17*	GS-35461	Broiling Element Gasket Seal	2
	LG-26867	Legs, 6" Bullet	4		GS-25662	Broiling Element Gasket Seal	1
	FT-29080	Feet, Seismic, 6"	4	18*	1013741	Broiling Element Bracket	1
9	5014033	Drip Tray Assembly	1	19*	CN-3654	Broiling Element Contactor	1

*NOT SHOWN

PARTS INFORMATION

TOP INTERIOR AND RIGHT SIDE

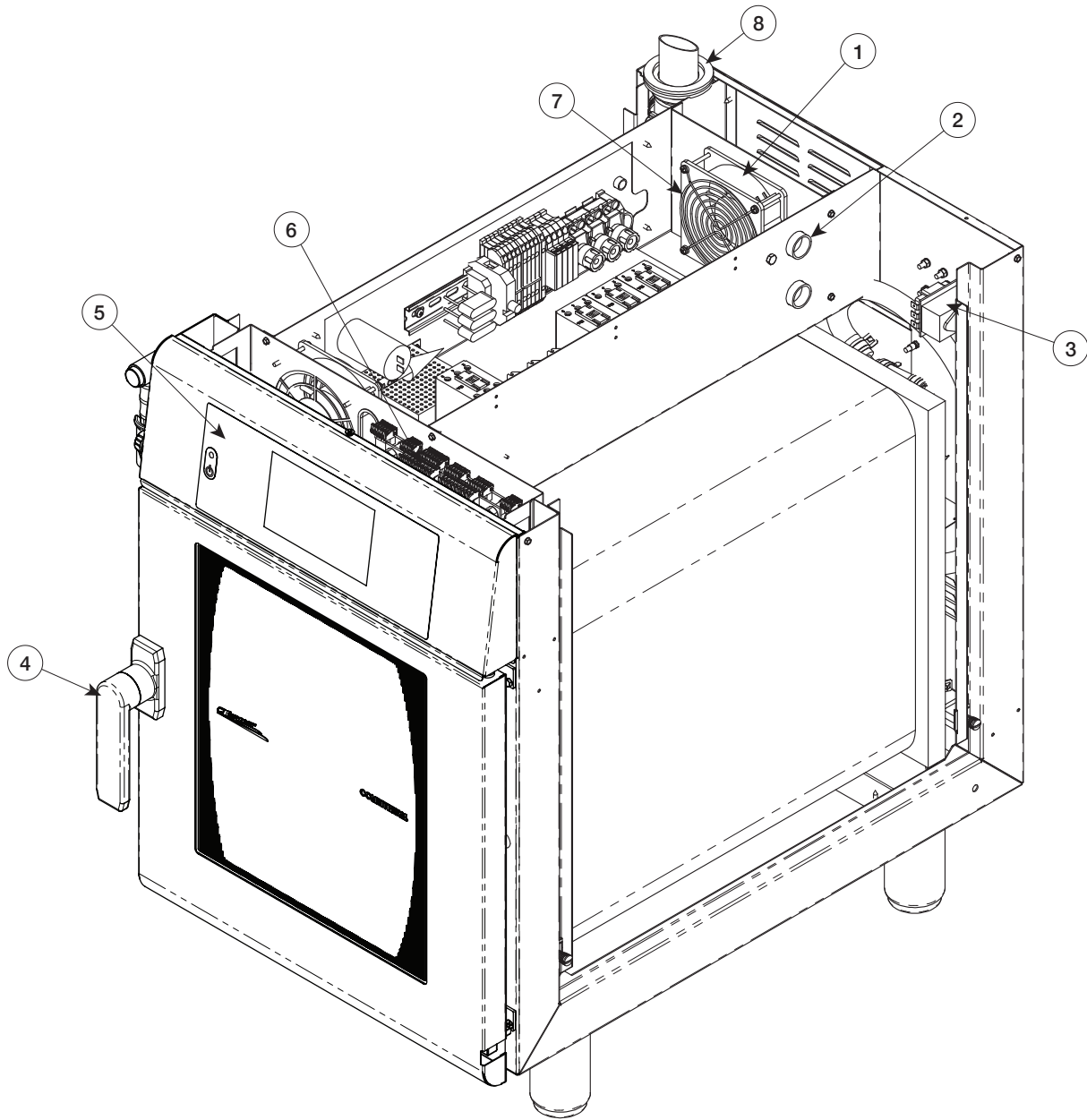

RIGHT SIDE VIEW

Item	Part	Description	Qty.
1	FA-36957	Fan, Box, 70CFM, 230V, 50-60Hz	1
2	BU-3378	Bushing, Snap, 1-1/8", Black	2
3	TT-3750	Thermostats, CT, Safety, 340°C, 208-240V	1
	TT-36204	Thermostat, Thermal, Cutout, 340°C Fail Safe Type, 380-415V	1
4	HD-29635	Handle, Door Pendulum	1
5	PE-37221	Panel Overlay for Touch Control, after 05/15	1
	PE-29870	Panel Overlay for Touch Control, prior to 05/15	1
	PE-36835	Panel Overlay for Simple Control, after 09/14	1
	PE-29869	Panel Overlay for Simple Control, prior to 09/14	1
6	BA-34670	Board, Relay	1
7	GD-2396	Fan Guard	1
8	BU-28391	Bushing, Low Pressure Membrane	1

PARTS INFORMATION

INTERIOR REAR BEFORE 7/1/15

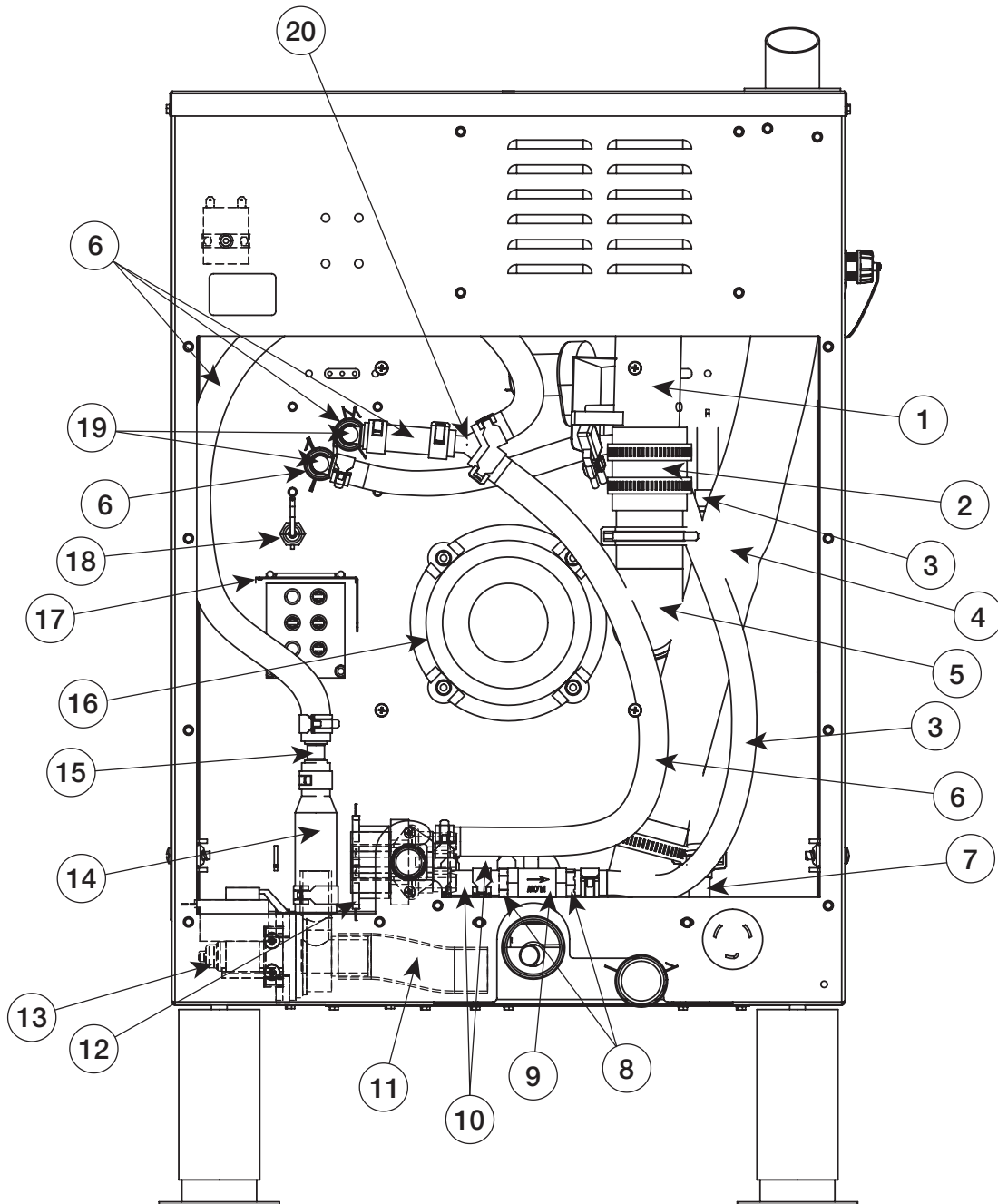

Item	Part	Description	Qty.	Item	Part	Description	Qty.
1	VA-26838	Valve, Baffle	2	11	HO-29667	Hose, Steam, 4" Long	*
2	HO-29435	Hose, 1-5/8"	*	12	VA-33723	Valve, Solenoid Triple	1
3	HO-2957	Hose, Steam Bypass, .775 x .575 x .100	*	13	DA-24973	Drain, Pump, Steam Generator	1
4	HO-29435	Hose, 1-5/8"	*	14	PB-29289	Plumbing, Reducer Hose 7/8"	1
5	EB-27207	Elbow, 1-7/8" ID	1	15	PB-29489	Coupler, 1/2" to 1/2", Straight	1
6	HO-28790	Hose, 1/2"	*	16	MO-29746	Motor, Fan Wheel, 230V	1
7	EB-22221	Elbow, 0.62 Dia., Center R.875	1	17	1012981	Cover, Element Splash	1
8	FT-29124	Fitting, 1/2" Barb to 3/8" NPT	2	18	PR-33724	Probe, 1650mm Wire Length	1
9	VA-29643	Valve, Flow Control, 0.06 GPM	1	19	EB-35867	Elbow, Barbed, 1/2" to 1/2"	2
10	HO-22255	Hose, 1/2" Flex, Clear, 2-3/4" Lg	*	20	PB-27838	Plumbing, Nylon, 1/2"	1

* ORDER PER FOOT

PARTS INFORMATION

INTERIOR REAR AFTER 7/1/15

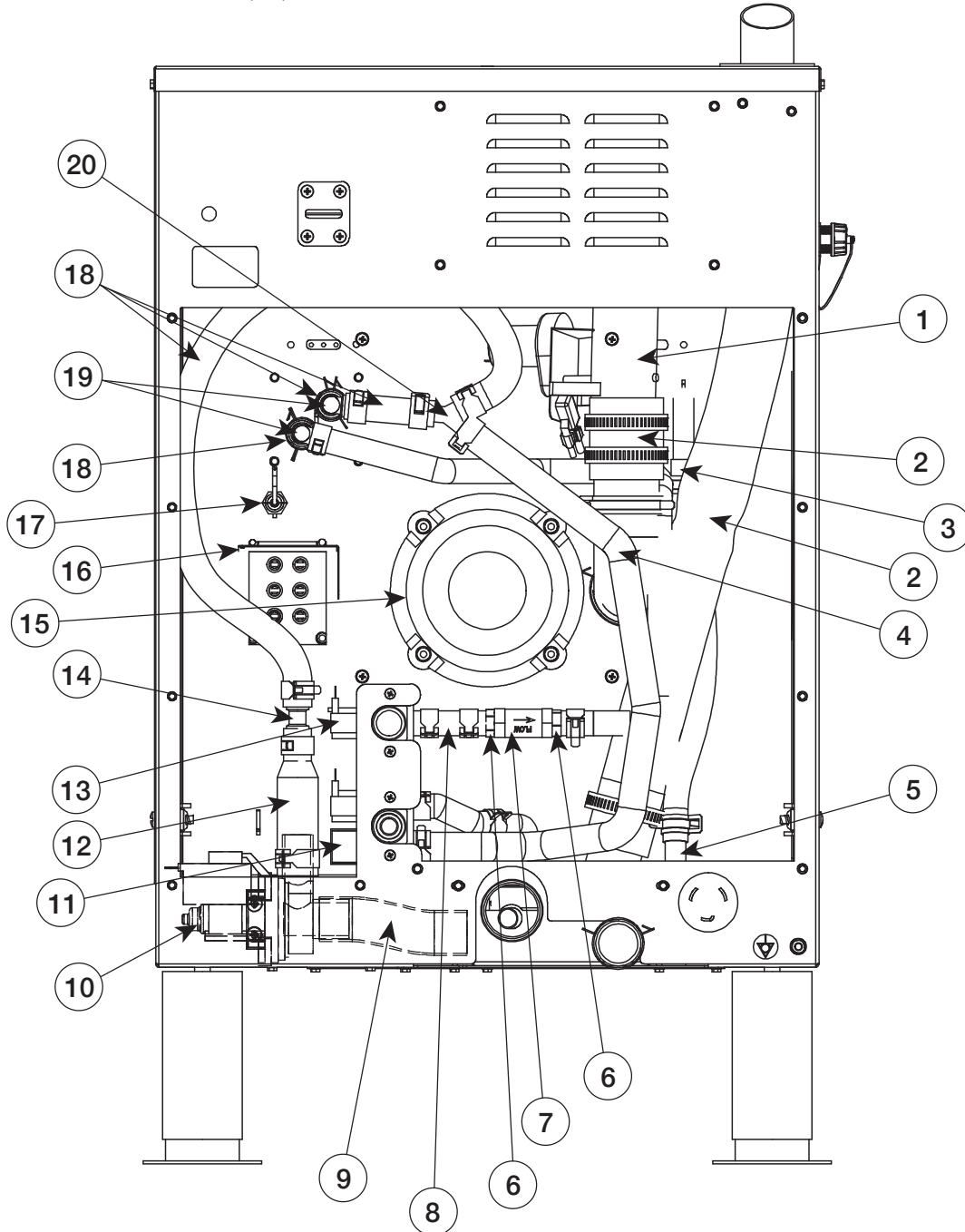

Item	Part	Description	Qty.	Item	Part	Description	Qty.
1	VA-26838	Valve, Baffle	2	11	VA-37014	Single Solenoid Valve, 208-240V	1
2	HO-29435	Hose, 1-5/8"	*	12	PB-29289	Plumbing, Reducer Hose 7/8"	1
3	HO-2957	Hose, Steam Bypass, 0.775 x 0.575 x 0.100	*	13	VA-37015	Double Solenoid Valve, 208-240V	1
4	EB-27207	Elbow, 1-7/8" ID	1	14	PB-29489	Coupler, 1/2" to 1/2", Straight	1
5	EB-22221	Elbow, 0.62 Diameter., Center R.875	1	15	MO-29746	Motor, Fan Wheel, 230V	1
6	FT-29124	Fitting, 1/2" Barb to 3/8" NPT	2	16	1012981	Cover, Element Splash	1
7	VA-29643	Valve, Flow Control, 0.06 GPM	1	17	PR-33724	Probe, 1650mm Wire Length	1
8	HO-22255	Hose, 1/2" Flex, Clear, 2-3/4" Lg	*	18	HO-28790	Hose, 1/2"	*
9	HO-29667	Hose, Steam, 4" Long	*	19	EB-35867	Elbow, Barbed, 1/2" to 1/2"	2
10	DA-24973	Drain, Pump, Steam Generator	1	20	PB-27838	Plumbing, Nylon, 1/2"	1

* ORDER PER FOOT

PARTS INFORMATION

DIRECTIONAL PANEL ASSEMBLY

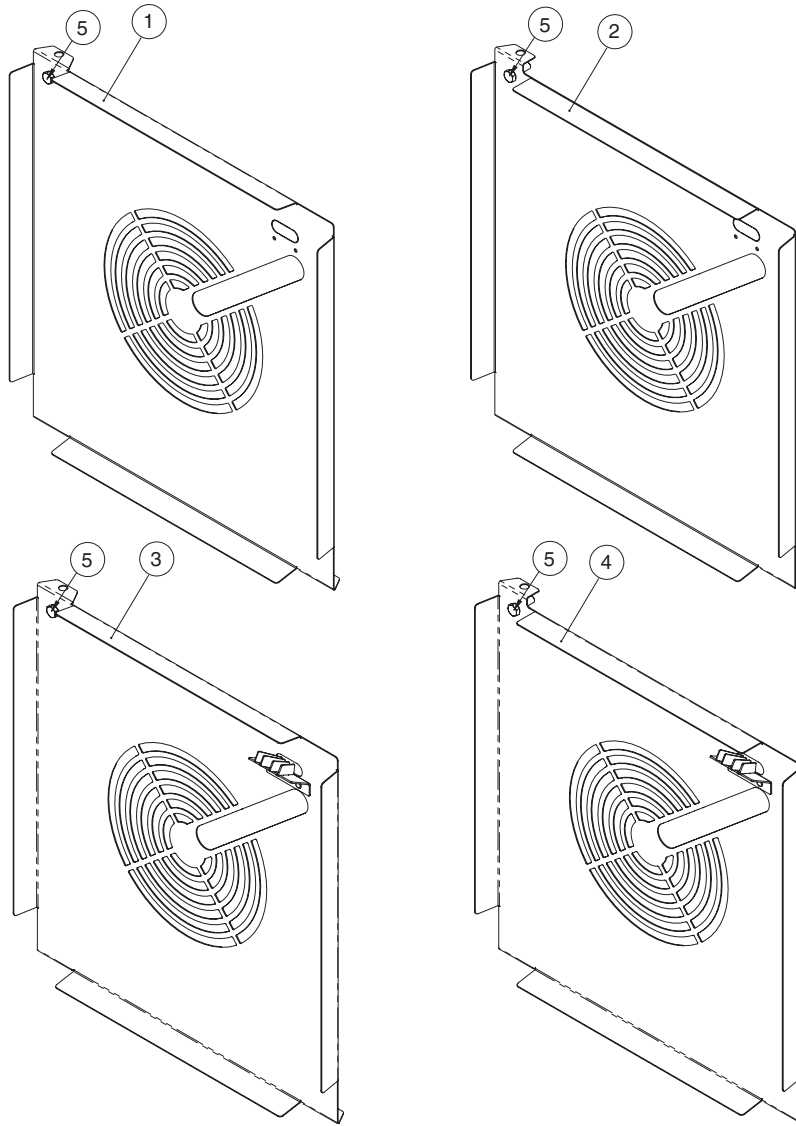

Item	Part	Description	Qty.
1	5016146	Directional Panel, no Cleaning	1
2	5016147	Directional Panel, no Cleaning, with Broiling Element	1
3	5016701	Directional Panel, with Cleaning	1
4	5016702	Directional Panel, with Broiling Element and Cleaning	2
5	SC-22924	Screw, M6 x 1.0 x 20mm Hex	1

PARTS INFORMATION

COMBITHERM MOTOR

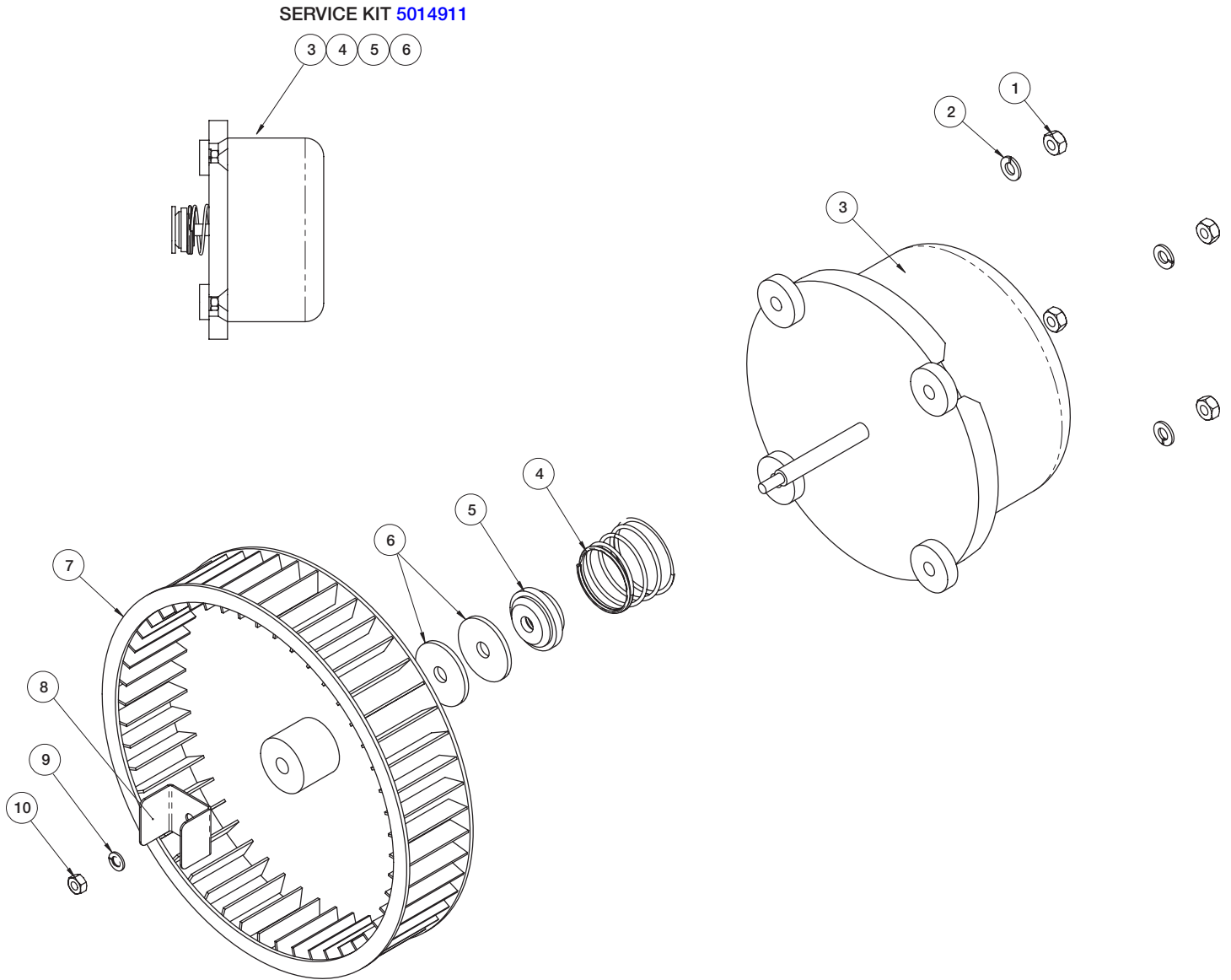

Item	Part	Description	Qty.
1	NU-22291	Nut, M6-1.0 x Hex 18-8, S/S	1
2	WS-22302	Washer, Split Lock	1
3**	MO-29746	Motor, 230V, 2 Speed	1
4**	SD-23939	Spring	1
5**	BU-29663	Bushing, Motor Shaft	1
6**	WS-29661	Washer, Motor Shaft Seal	2
7	WH-29634	Wheel, Fan, 197mm OD	1
8	1013034	Bracket, Disintegration Box	4
9	WS-22301	Washer, M5 Split Lock	1
10	NU-22289	Nut, M5-0.8 Hex Nut, 18-8 Din #934	1

**INCLUDED IN SERVICE KIT [5014911](#)

PARTS INFORMATION

ELECTRICAL CORD & ROUTING (AVAILABLE ONLY ON 208V, 1PH MODELS)

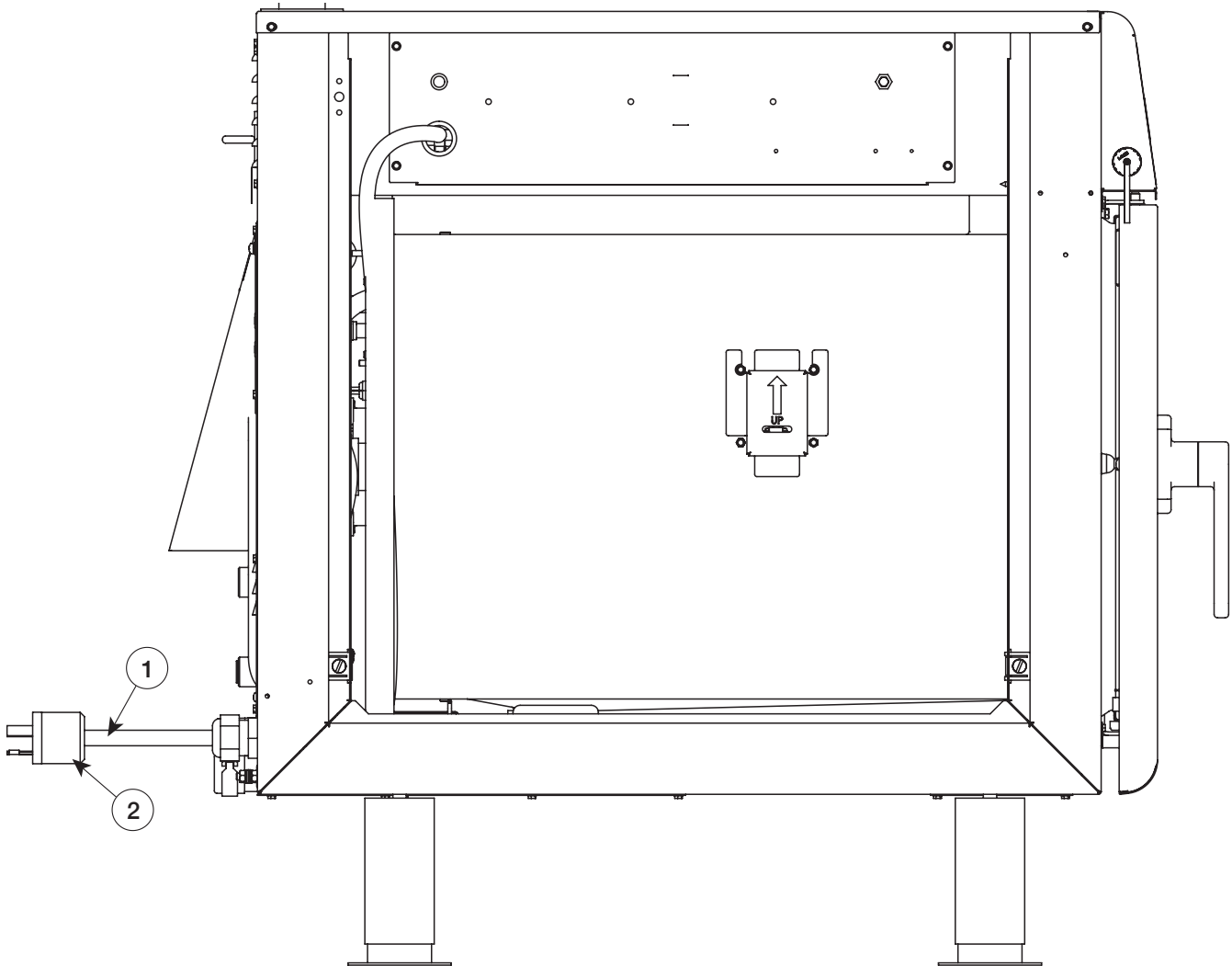

CD-3304 & PG-34207 (208V, 1PH, 60HZ ONLY)
CD-36230 (208-240V, 1PH, 50HZ ONLY)

Item	Part	Description	Qty.
1	CD-3304	Cord, 208V, 1PH, 60Hz Only, 10 Gauge, 3 Conductor	1
	CD-36230	Cord, 208-240V, 1PH, 50Hz Only	1
2	PG-34207	Plug, 208V, 1PH, 60Hz Only	1

*NO CORD/PLUG (ALL OTHER MODELS)

PARTS INFORMATION

PLUMBING

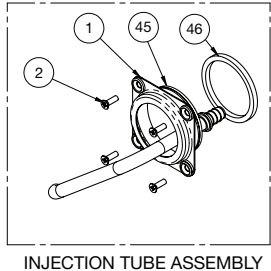
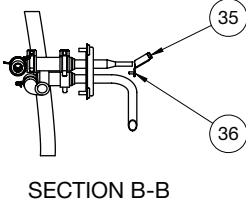
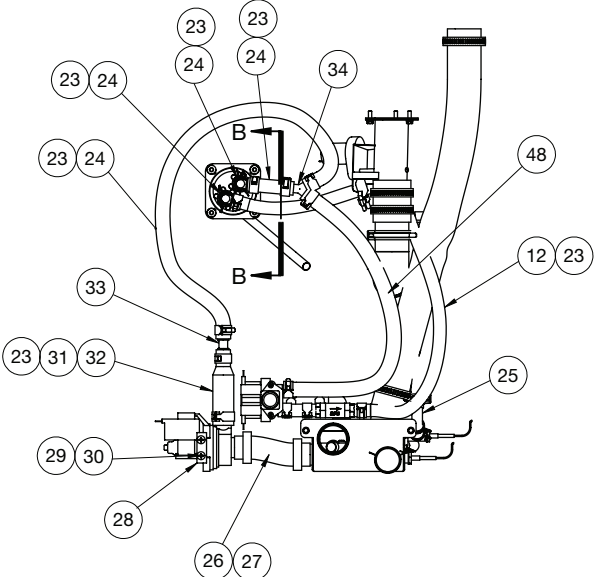
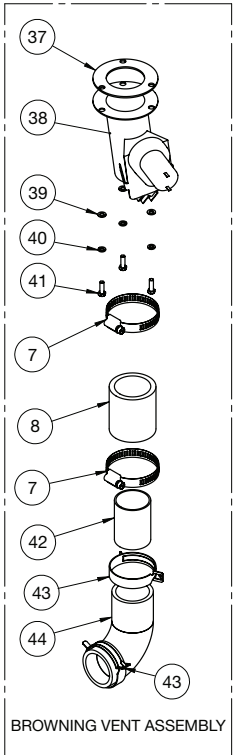
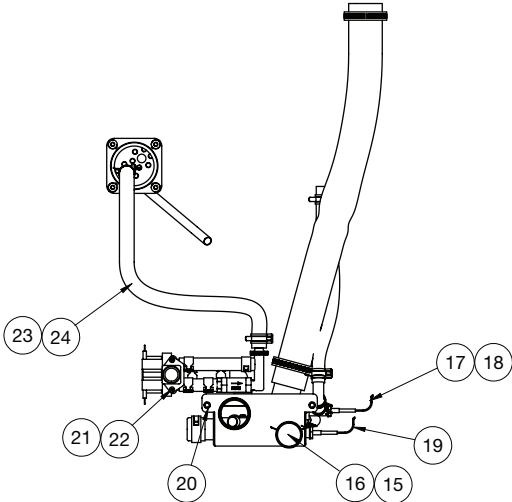
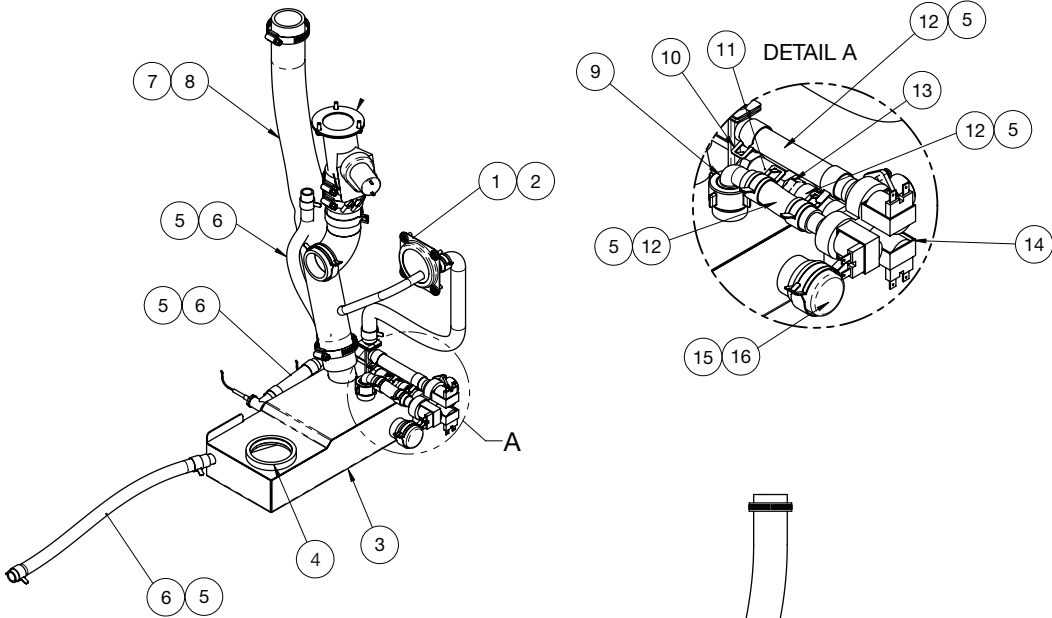

SHOWN WITH CLEANING

PARTS INFORMATION

PLUMBING

Item	Part	Description	Qty.
1	CV-23896	Cover, ML, S/S Ring, Light Coved Corner	1
2	SC-22281	Screw, M5 x 0.8 x 16mm Flat	4
3	5013627	Condensor Tank Weld	1
4	SA-22212	Condensate Seal	1
5	CM-28145	Clamp, Hose, 20mm	12
6	HO-2957	Hose, Translucent Silicon	1
7	CL-22234	Clamp, Worm Gear, 40-60, Hose - without cleaning	2
		Clamp, Worm Gear, 40-60, Hose - with cleaning	4
8	HO-29435	Hose, 1-5/8" (41mm) ID	1
9	HO-22116	Fitting, Elbow, 90 Deg.	1
10	PB-29162	Manifold, Injection Tube	1
11	VA-29643	Valve, Flow Control, 0.06 GPM	1
12	HO-22255	Hose, 1/2" Flex, Clear	1
	HO-2957	Hose, Translucent Silicon, 15" LG AFTER 7/1/15	1
13	FT-29124	Fitting, 1/2" Barb to 3/8" NPT Adaptor	1
14	VA-33723	Valve, CT, Solenoid Triple	1
15	CM-29038	Clamp, Hose, 38mm	2
16	CP-29648	Cap, Push-on, Fits on 1-1/4" OD	2
17	SA-25061	Probe Seal	1
18	PR-33751	Probe, B5 Bypass	1
19	PR-33751	Condensate Probe	1
20	SC-29871	Screw, #8 x 1/2" Hex FLg	2
21	WS-22300	Washer, Split Lock	2
22	SC-22273	Screw, M4 x 0.7 x 10mm Pan	2
23	CM-29301	Clamp, Hose, 23mm - without cleaning	2
		Clamp, Hose, 23mm - with cleaning	11
24	HO-28790	Hose, 1/2" (13mm) ID, Hi-Temp	1
25	EB-22221	Elbow, 0.63 Dia., Center R.875	1
26	HO-29667	Hose, Steam, 4.5" Lg	1
27	CM-22794	Clamp, Gear, HSS, 20 S/S, Range 3/4"-1-3/4"	2
28	DA-24973	Pump, Cleaning	1
29	WS-22302	Washer, Split Lock	2
30	SC-27078	Screw, M6 x 1.0 x 10mm Pan	2
31	CM-29037	Clamp, Hose, 32mm	1
32	PB-29289	Reducer, 7/8" x 1/2"	1
33	PB-29489	Coupler, 1/2" to 1/2"	1
34	PB-27838	Plumbing, Nylon, 1/2" Y	1
35	5016164	Cleaning Deflector Weld Assembly	1
36	RI-27108	Rivet, Sealed	2
37	SA-26890	Seal, Vent Motor	1
38	VA-26838	Vent Motor	1
39	WS-22295	Washer, Flat M5 S/S	3
40	WS-22301	Washer, M5 Split Lock S/S 18-8	3
41	SC-22926	Screw, M5 x 0.8 x 16mm, Hex	3
42	FT-27406	Coupling w/o. Stop, 1.5"	1
43	CM-29039	Clamp, Hose, 55mm	2
44	EB-27207	Washer, Drain Support	1
45	5016205	Injector Tube Weld Assembly - without Cleaning	1
	5016140	Injection Tube Weld Assembly - with Cleaning	1
46	SA-23934	O-Ring, Light	1
47*	EB-35867	Elbow, Barbed, 1/2" to 1/2"	2
48	HO-28790	Hose, 1/2" ID, Hi-Temp, 19.5" LG AFTER 7/1/15	1

*NOT SHOWN

PARTS INFORMATION

CONTROL ASSEMBLY - SIMPLE

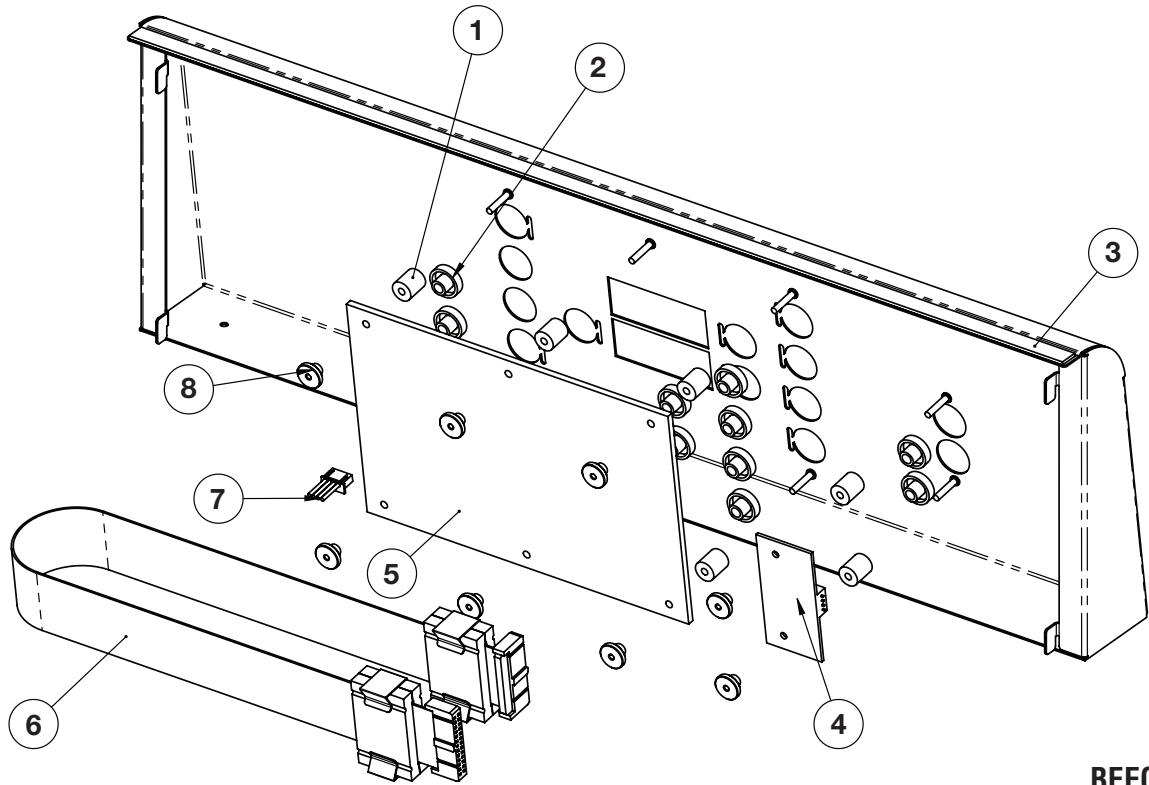

BEFORE 09/14

67451

Item	Part	Description	Qty.
1	BU-25094	Bushing, Brass, Distance	8
2	CP-25405	Cap, 15mm Dia. x 8.5mm Button	13
3	GS-23622	Gasket, Foam 20" length	1
4	BA-34778	Board, On/Off	1
5	CC-29772	Control Assembly, Simple	1
6	CB-34033	Cable, Communication, 510mm	1
7	CB-29873	Cable, On/Off Board	1
8	NU-25095	Nut, Knurled, M3, High, A2, S/S	8

PARTS INFORMATION

CONTROL ASSEMBLY - SIMPLE

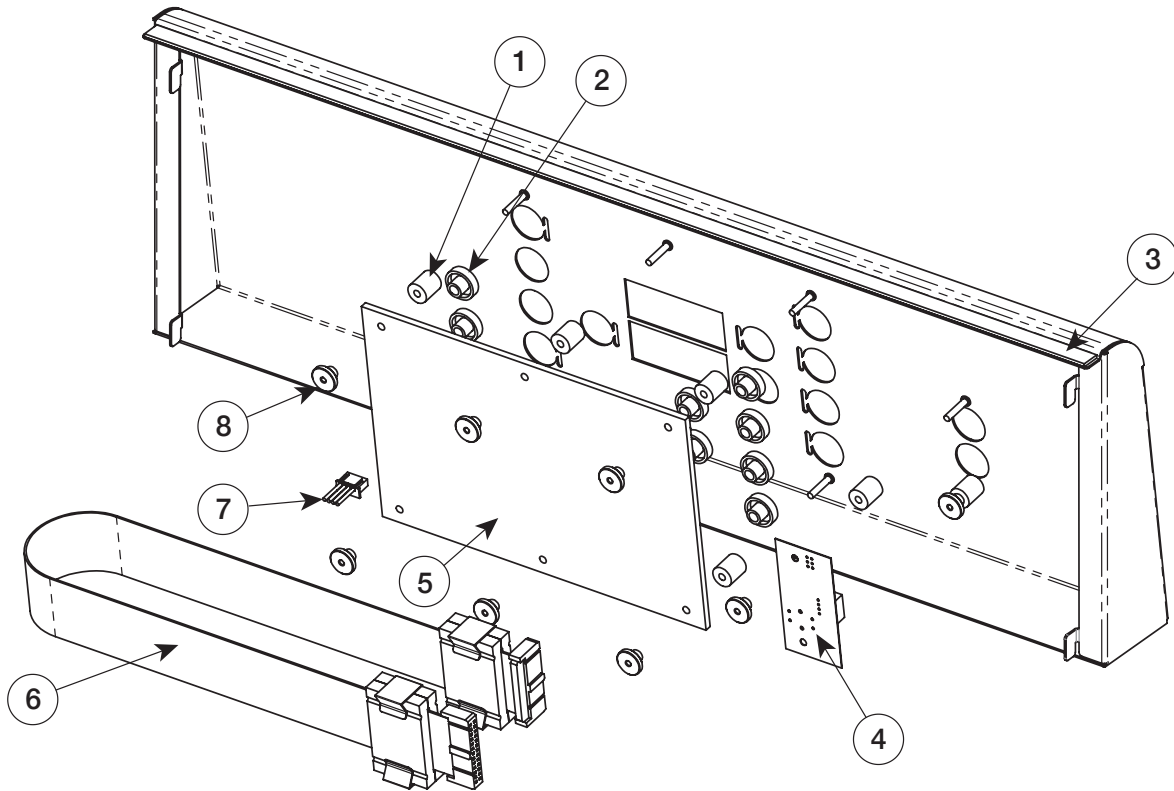

AFTER 09/14

67451

Item	Part	Description	Qty.
1	BU-25094	Bushing, Brass, Distance	8
2	CP-25405	Cap, 15mm Dia. x 8.5mm Button	11
3	GS-23622	Gasket, Foam 20" length	1
4	CC-36871	Board, On/Off	1
5	CC-29772	Assembly, Control Simple Basic	1
6	CB-34033	Cable, Communication, 510mm	1
7	CB-29873	Cable, On/Off Board	1
8	NU-25095	Nut, Knurled, M3, High, A2, S/S	8

PARTS INFORMATION

CONTROL ASSEMBLY - EXPRESS TOUCH

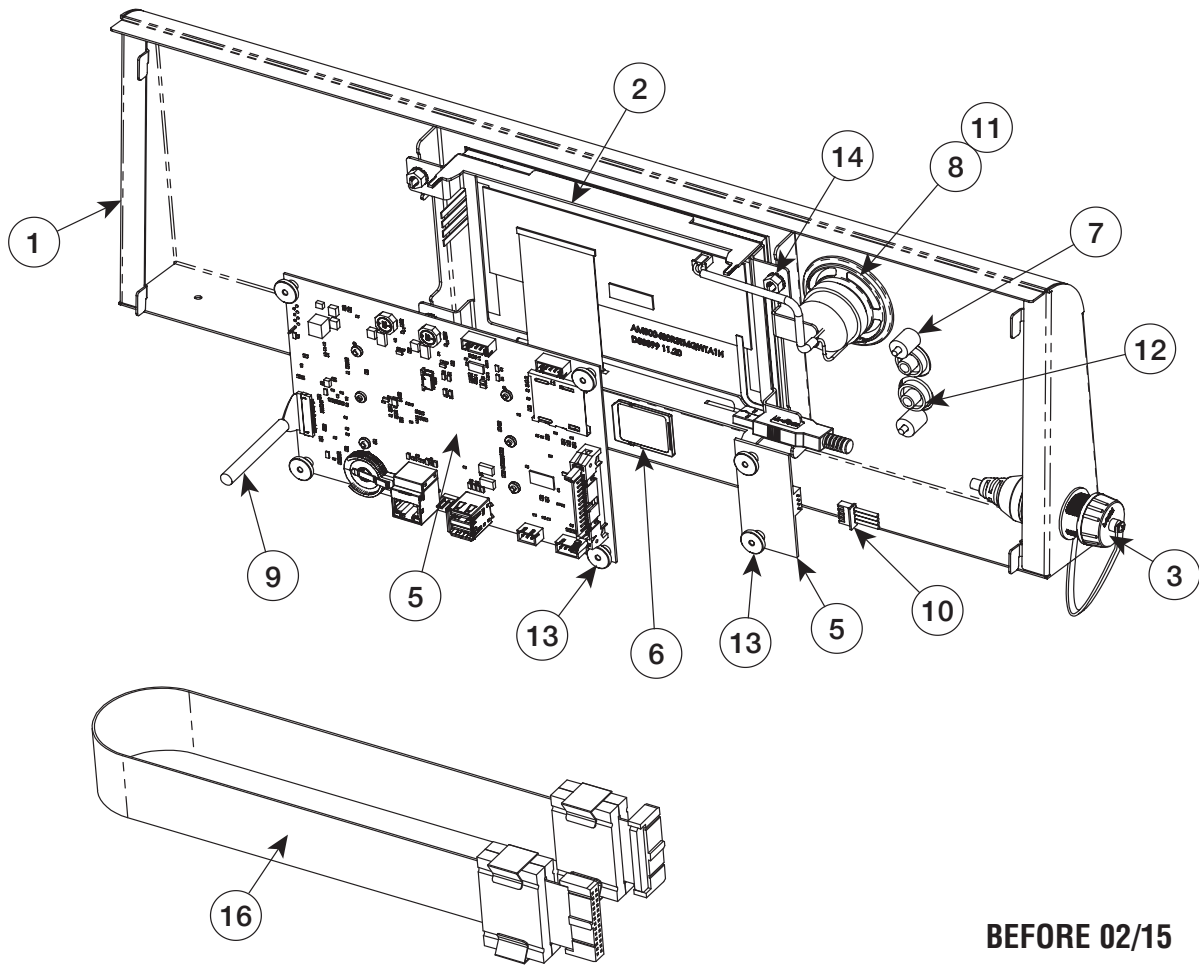

BEFORE 02/15

67445

Item	Part	Description	Qty.
1	5014363	Spot Assy, Control S/S	1
	5014761	Spot Assy, Control Black	1
	5014762	Spot Assy, Control Burgundy	1
	5014763	Spot Assy, Control Custom	1
2	5014562	Assy, Display Mounting Bracket	1
3	5014750	HACCP PKG With USB Port	1
4	BA-29719	Board, Control Simple Plus	1
5	BA-34778	Board, ON/OFF, Touch Screen	1
6	BA-35138	Programmed Board	1
7	BU-25094	Bushing, ML, Brass, Distance	2
8	BZ-34675	Buzzer, Speaker, IND Rated 8 Ohm	1
9	CB-29872	Cable, LVDS, Simple Plus	1
10	CB-29873	Cable, ON/OFF Board	1
11	CB-34914	Cable, Speaker, Board, Touch	1
12	CP-25405	Cap, 15mm Dia x 8.5 mm Button	2
13	NU-25095	Knurled M3 High A2 S/S	6
14	NU-27851	Nut-Hex 5 mm With Star Washer	4
15	PE-29870	Panel Overlay, Touch	1
16	CB-34033	Cable, Communication, 510mm	1

PARTS INFORMATION

CONTROL ASSEMBLY - EXPRESS TOUCH

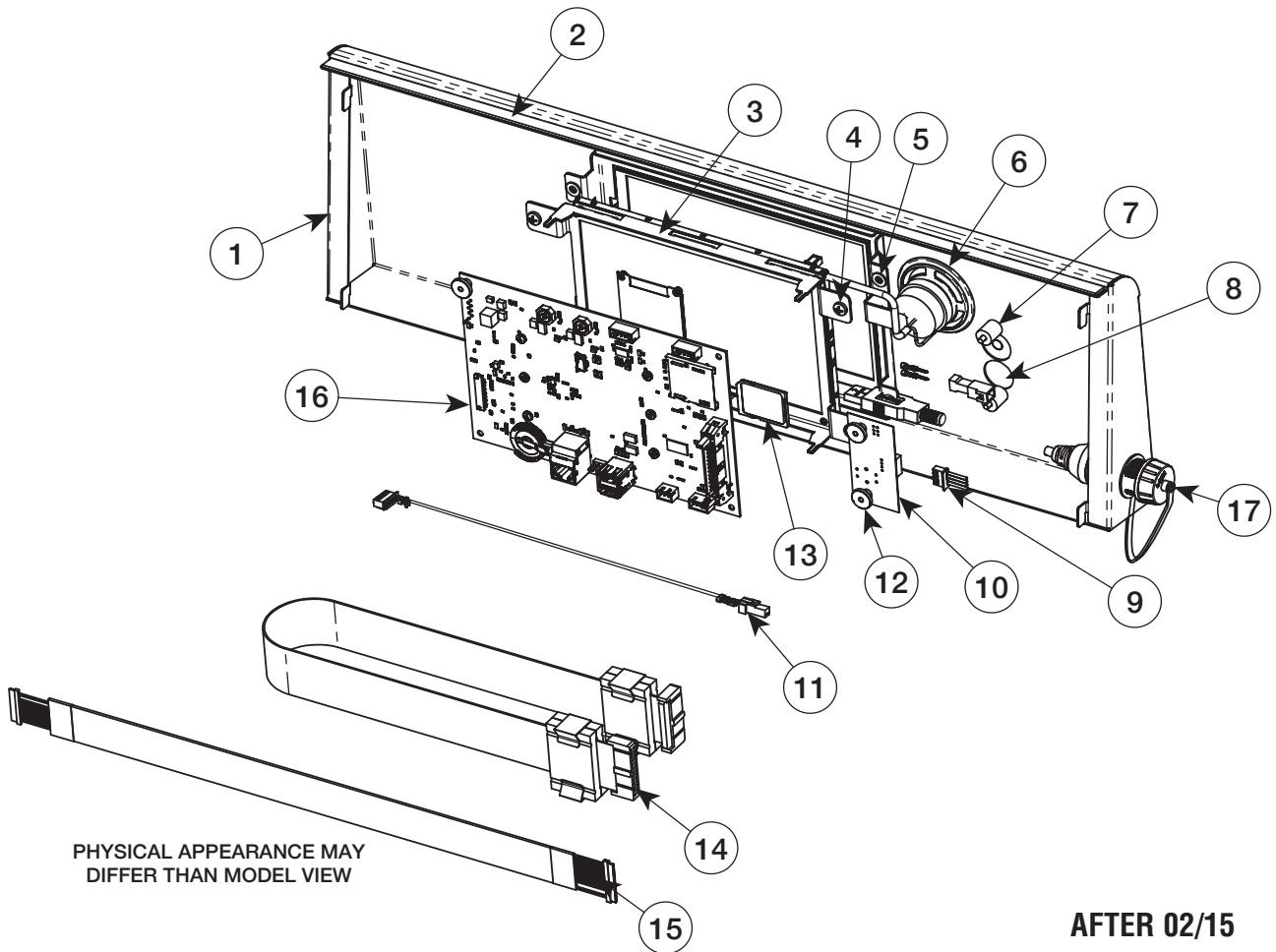

68704

Item	Part	Description	Qty.
1	5014363	Spot Assy, Control RH S/S	1
	5015265	Spot Assy, Control LH S/S	1
2	GS-23622	Gasket, Foam 20" Length	1
3	5021078	Assy, Display Mounting Bracket	1
4	SC-22271	M4 x 6mm PH PAN HD M/S 0.7	4
5	WS-22294	Washer, Flat M4 18-8 S/S	4
6	BZ-34675	Buzzer, Speaker, with Cable	1
7	BU-25094	Bushing, Brass, Distance	2
8	PE-37221	Display, Overlay	1
9	CB-29873	Cable, ON/OFF Board	1
10	CC-36871	Board, ON/OFF Touch	1
11	CB-37252	Cable, Power LCD Screen	1
12	NU-25095	Knurled M3 High A2 S/S	3
13	BA-35138	Program Board	1
14	CB-34033	Cable, Communication, 510mm	1
15	CB-38234	Cable, LVDS, Interface Board	1
16	BA-29719	Board, Control Simple Plus	1
17	5014750	HACCP PKG with USB Port	1

PARTS INFORMATION

TOUCH CONTROL REPLACEMENT KIT (EXPRESS TOUCH ONLY)

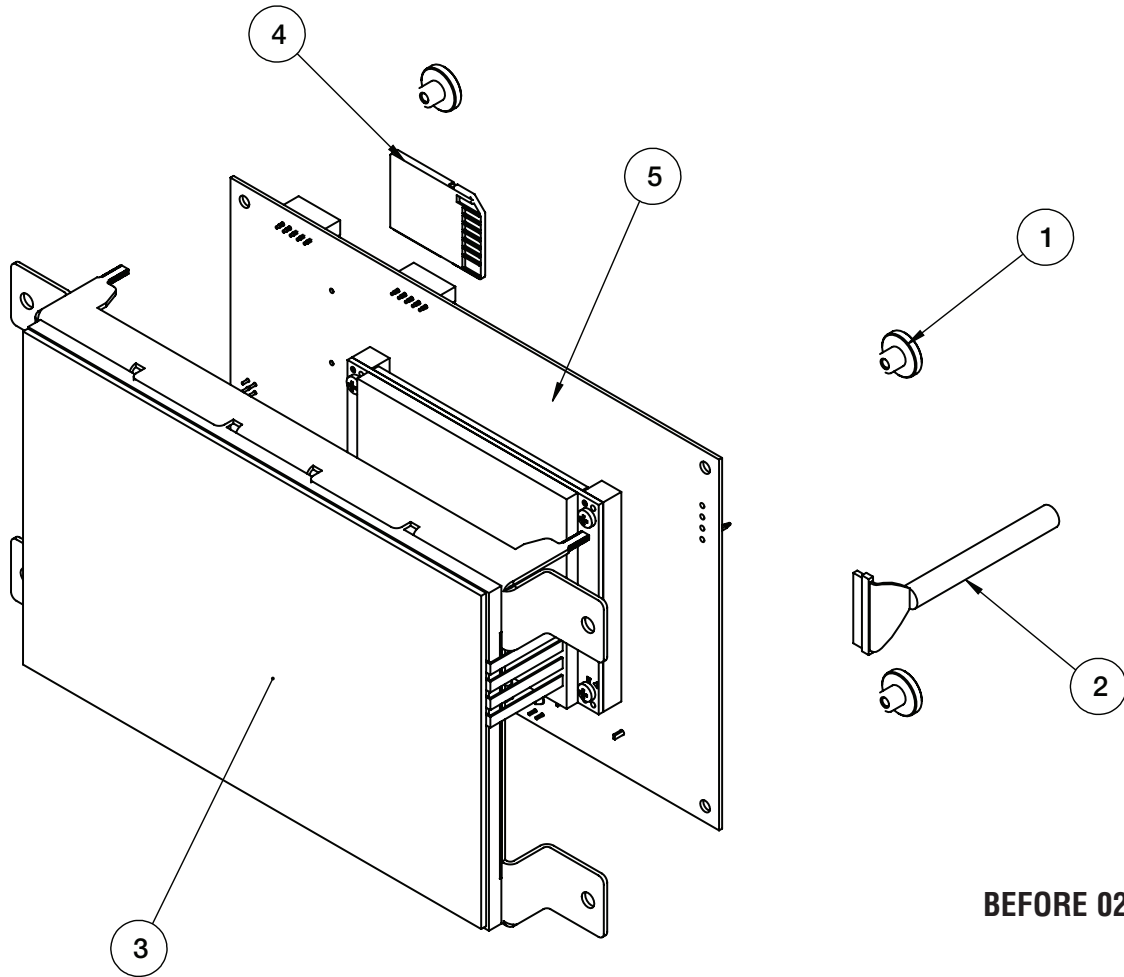

BEFORE 02/15

Control Replacement Kit - 5015926

Item	Part	Description	Qty.
1	NU-25095	Nut, Knurled, M3 High A2 S/S	4
2	CB-38234	Cable, LVDS, Express Touch	1
3	5014562	Display Mounting Bracket Assembly	1
4	BA-35138	Board, Compact Flash	1
5	BA-29719	Board, Interface	1

PARTS INFORMATION

TOUCH CONTROL REPLACEMENT KIT WITHOUT GLASS (EXPRESS TOUCH ONLY)

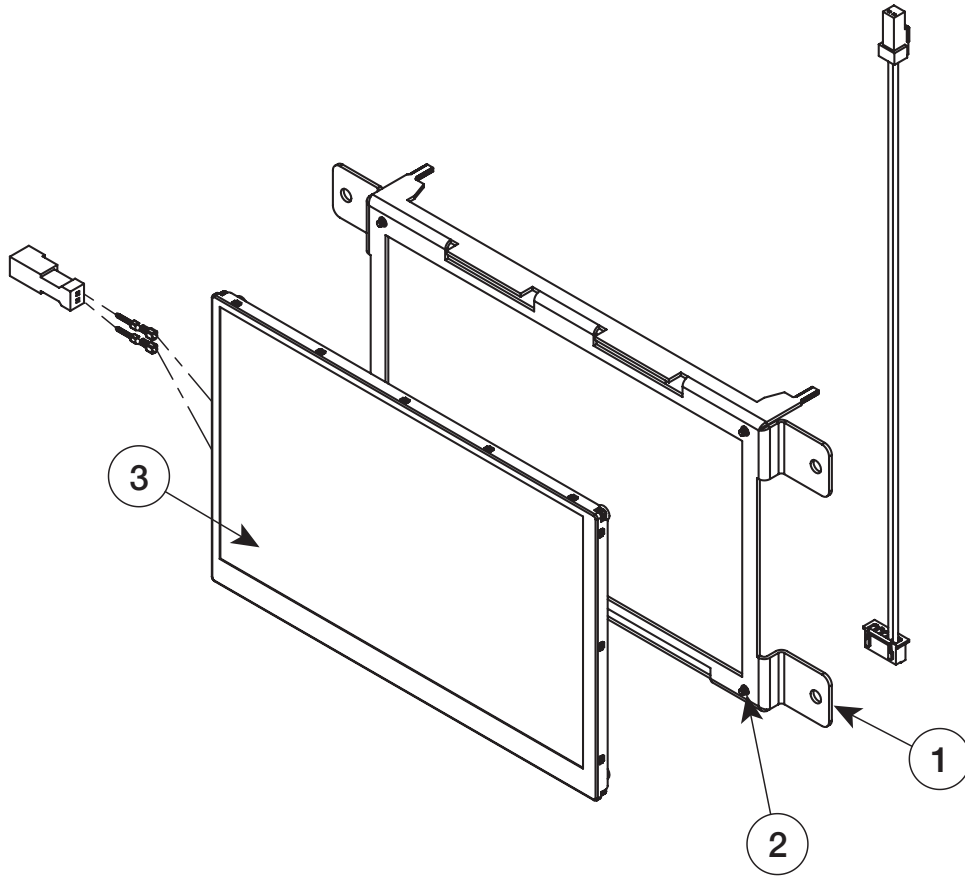

AFTER 02/15

Control Replacement Kit - [5021693](#)

Item	Part	Description	Qty.
1	1017353	Bracket, LCD Mountin	1
2	SC-37356	Screw, PPH, SST	4
3	BA-37222R	Display Kit Without Touch Glass	1

PARTS INFORMATION

TOUCH CONTROL CONVERSION KIT (CONVERT DOUBLE BUTTON TO SINGLE BUTTON)

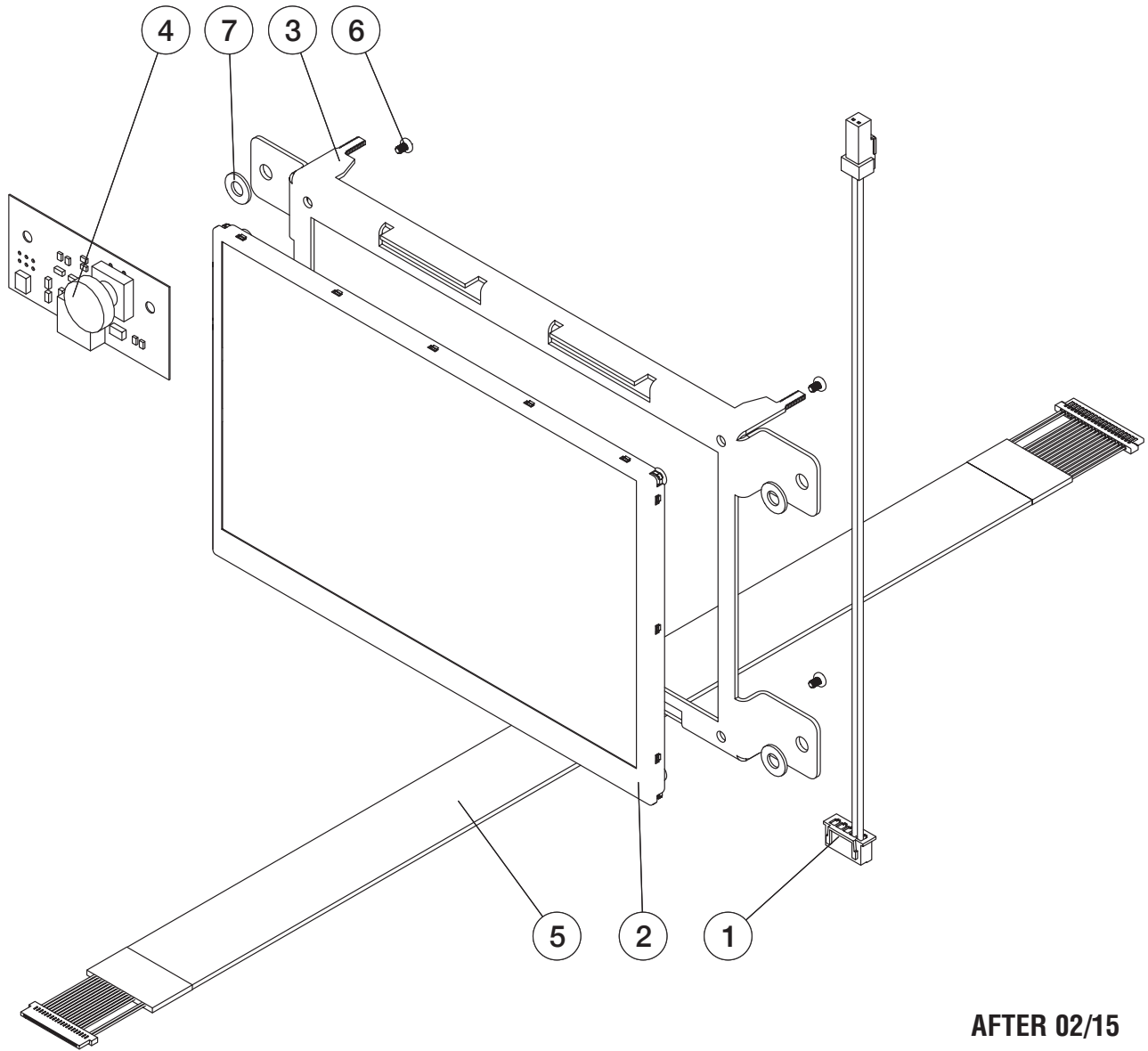

AFTER 02/15

Control Replacement Kit - 5021512

Item	Part	Description	Qty.
1	CB-37252	CABLE, POWER LCD SCREEN	1
2	BA-37222	7" DISPLAY, W/O TOUCH GLASS	1
3	1017353	BRACKET, LCD MOUNTING	1
4	CC-36871	BOARD, ON/OFF, ONE BUTTON	1
5	CB-38234	CABLE, LVDS, TWISTED PAIR	1
6	SC-37356	SCREW, PPH, SST	4
7	WS-22294	WASHER, FLAT M4 18-8 S/S	4

PARTS INFORMATION

CATALYTIC CONVERTER

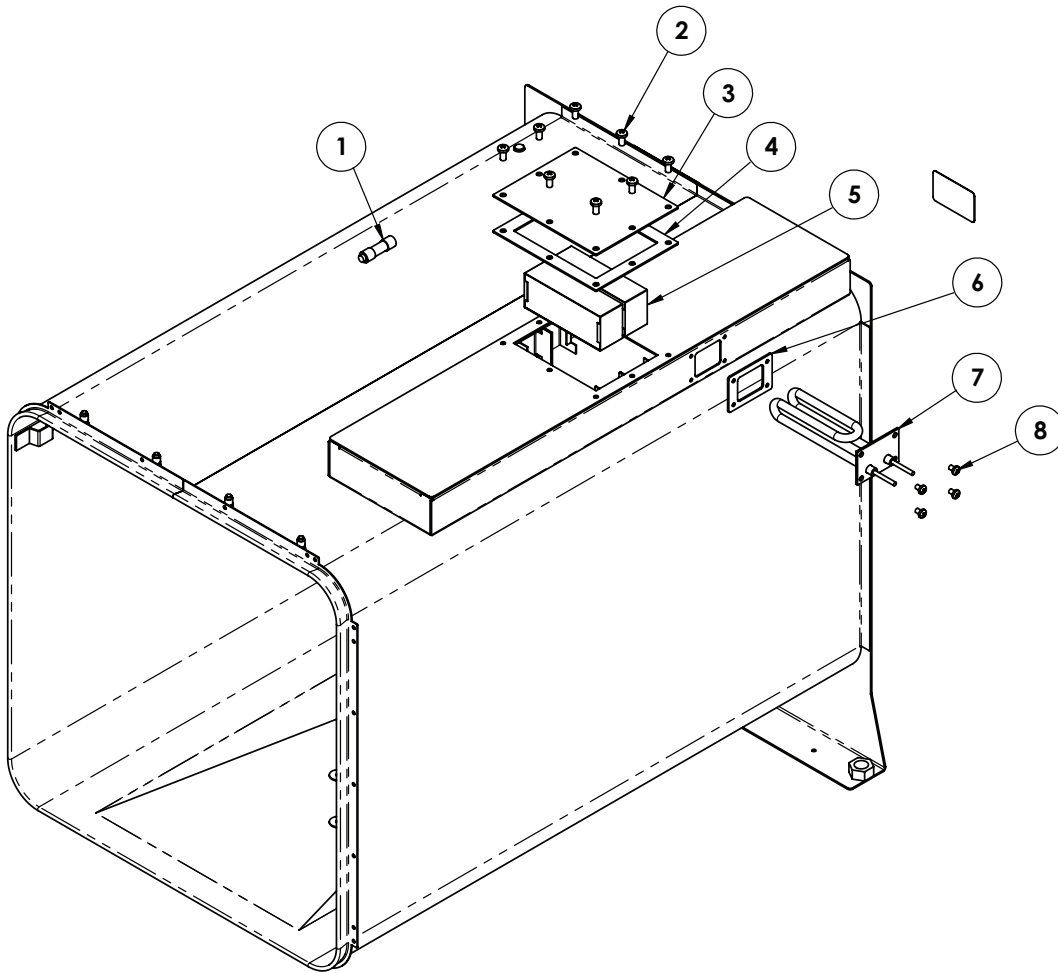

67780

Item	Part	Description	Qty.
1	FU-34938	Fuse, 3 Amp	1
2	SC-22766	Screw, M4 x 0.8 x 10mm Pan	8
3	1014243	Cover	1
4	GS-35495	Gasket Seal	1
5	FI-29651	Filter	2
6	GS-35494	Gasket Seal	1
7	EL-35051	Element, Heater	1
8	SC-22271	Screw, M4 x 0.7 x 10mm Pan	4

PARTS INFORMATION

BROILING ELEMENT

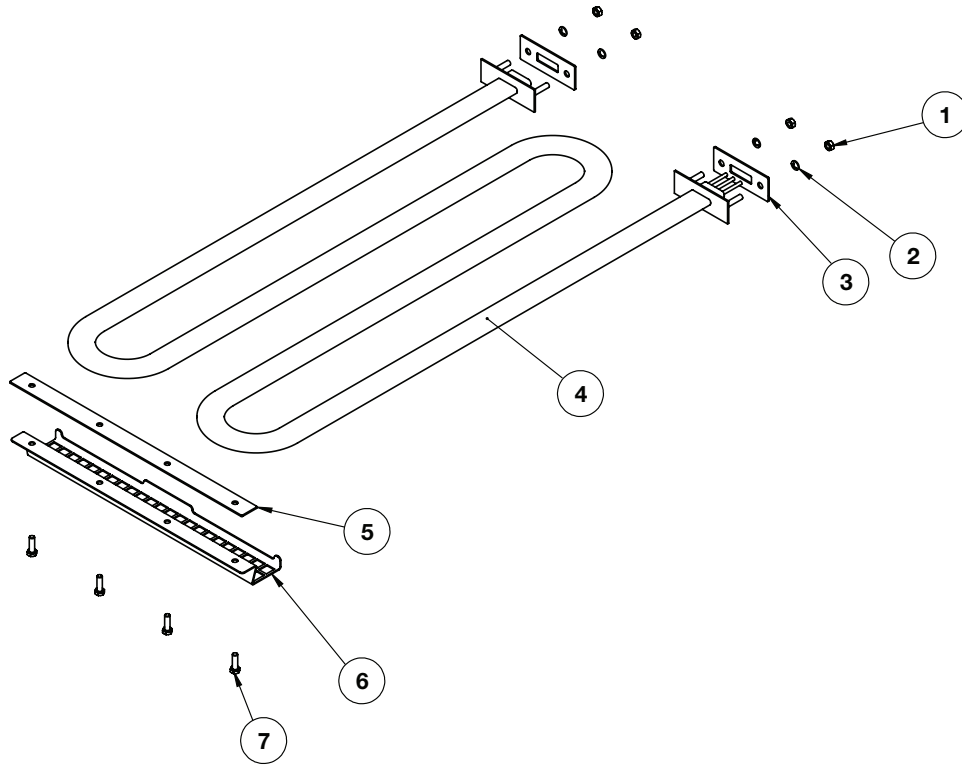

Item	Part	Description	Qty.
1	NU-22289	Nut, M5-0.8 Hex Nut 18-8 din #934	4
2	WS-22301	Washer, M5 Split Lock	4
3	GS-35461	Gasket, Element Seal	2
4	EL-35057	Element, 208-240V	1
	EL-36032	Element, 380-415V	1
5	GS-35662	Gasket, Seal, Mounting Bracket	1
6	1013741	Bracket, Broiling Element	1
7	SC-22926	Screw, M5 x 0.8 x 16mm, Hex	4

PARTS INFORMATION

CONDENSER TANK

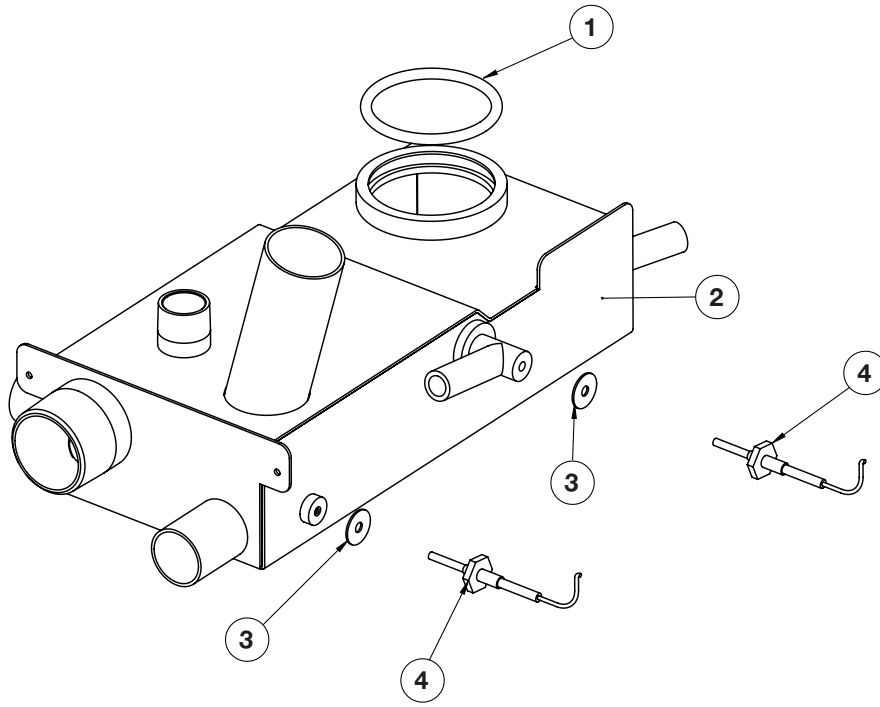

5013628

Item	Part	Description	Qty.
1	SA-22212	O-Ring, Red, Silicone 70 Durometer, 225C, 59.6mm x 5.33mm	1
2	5013627	Condenser Tank Weld Assembly	1
3	SA-25061	Seal, T-Couple Probe	2
4	PR-33751	Probe, Thermocouple 3050mm Wire Length	2

PARTS INFORMATION

LAMP ASSEMBLY

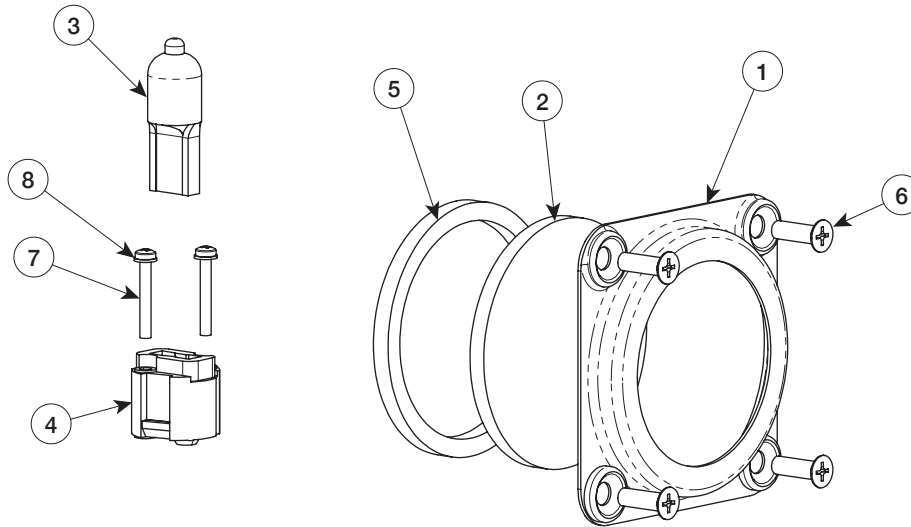

5016299

Item	Part	Description	Qty.
1	CV-23896	MN, S/S Ring, Light Coved Corner	1
2	LP-33413	CT, Glass, Light	1
3	LP-35865	Light Bulb, 230V, 40W	1
4	LP-37019	Socket, G9, Screw Mtg	1
5	SA-23934	O-Ring, Light, 7-20ML Elec.	1
6	SC-22281	Screw, M5 x 16 Flat Head Csink	4
7	SC-28846	Screw, M3 x 0.5 x 22mm Pan	2
8	WS-22299	Washer, M3 Split Lock	2

Prior to 7/2015

Item	Part	Description	Qty.
1	SC-23141	Screw	4
2	CV-26607	Oven Light Cover	1
3	GL-26608	Oven Light Glass	1
4	GS-26609	Oven Light Gasket	1
5	LP-35865	Light, 40W Bulb	1
6	LP-35866	Light, Snap-In Receptacle	1

Prior to 2/2013 (NOT interchangeable with [LP-35865](#) and [LP-35866](#))

Item	Part	Description	Qty.
5	LP-34206	Light, 40W Bulb	1
6	LP-34161	Light, Snap-In receptacle	1

PARTS INFORMATION

SMOKER CHIP TRAY ASSEMBLY

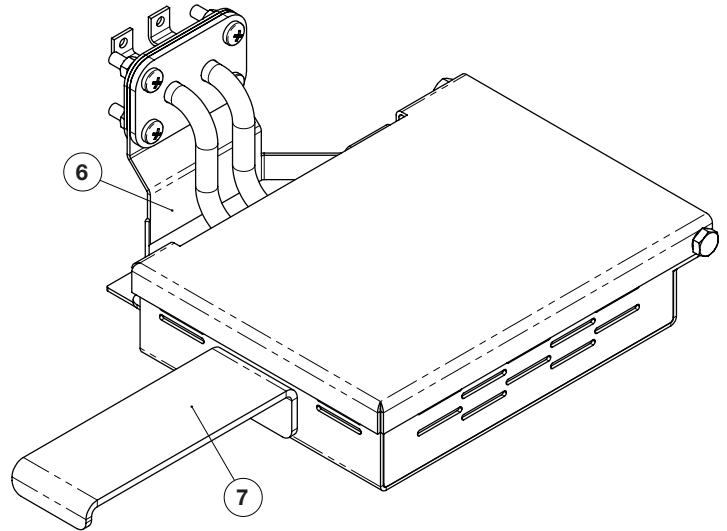
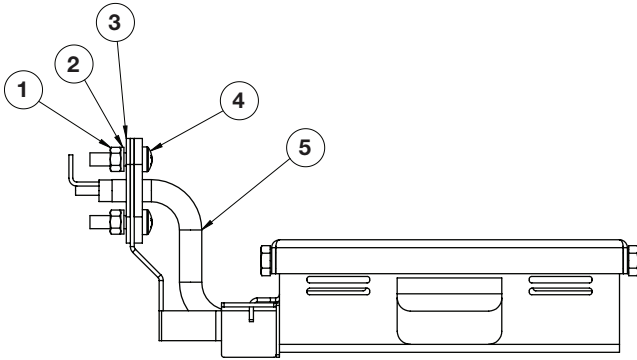

5015597

Item	Part	Description	Qty.
1	NU-22289	Nut, M5-0.8 Hex 18-8 Din #934	4
2	WS-22301	Washer, M5 Split Lock S/S 18-8	4
3	GS-35229	Gasket, Seal, Smoker Element	1
4	SC-22779	Screw, M5 x 0.8 x 20mm Pan	4
5	EL-35216	Element	1
6	5015311	Smoker Bracket	1
7	5015596	Smoker Box	1
8*	WC-22540	Wood Chips, Cherry, 2 lb. bag	1
9*	WC-22542	Wood Chips, Apple, 2 lb. bag	1
10*	WC-22544	Wood Chips, Sugar Maple, 2 lb. bag	1
11*	WC-2828	Wood Chips, Hickory, 2 lb. bag	1
12*	FU-34784	Fuse, Smoker, 5 Amp	1
	FU-33452	Fuse, Smoker, 6.3 Amp - 380-415V	2
13*	CE-26277	Cleaner Kit, Smoker	1

*NOT SHOWN

PARTS INFORMATION

OPTIONAL SINGLE POINT PROBE ASSEMBLY

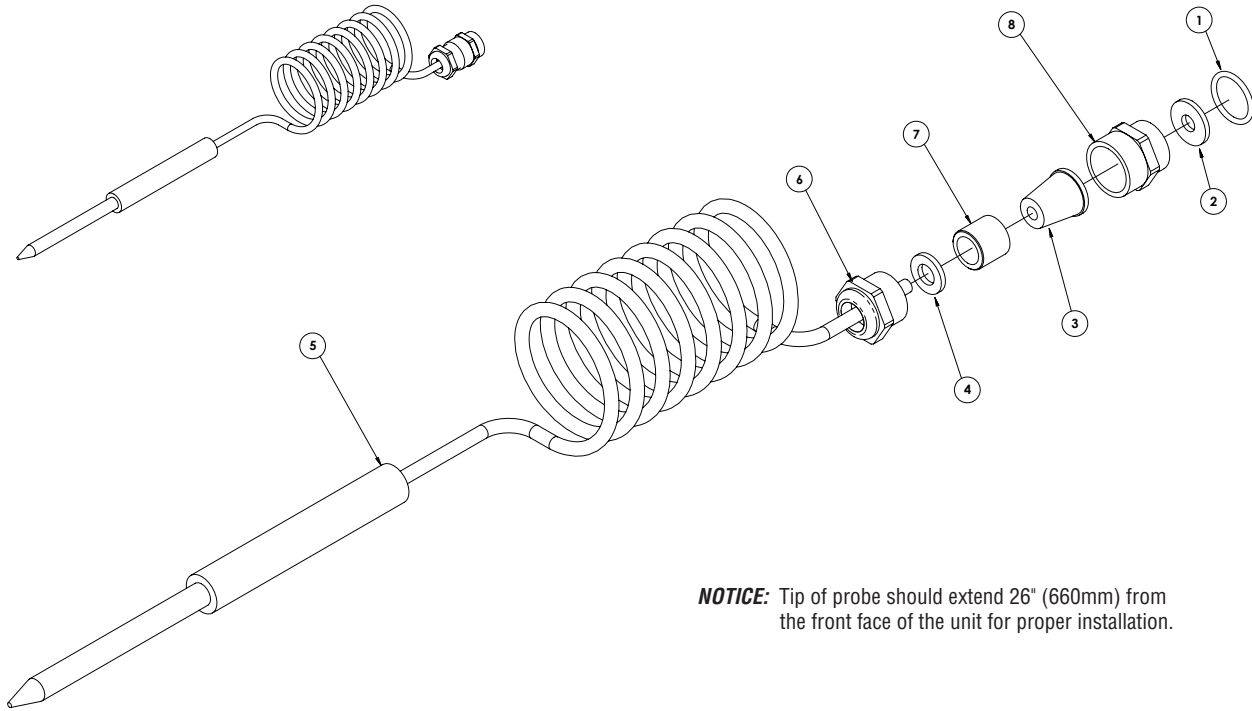

NOTICE: Tip of probe should extend 26" (660mm) from the front face of the unit for proper installation.

5014297

Item	Part	Description	Qty.
1	SA-22199	Seal, O-Ring	1
2	WS-22323	Washer, Flat	1
3	SA-22322	Seal, Insert, 4mm Dia.	1
4	WS-22297	Washer, Flat	1
5	PR-29650	Probe, 1300mm length	1
6	SA-22320	Seal, Top, PG9	1
7	SA-22321	Seal, Cone, PG9, Brass	1
8	PG-3826	Plugs, Adaptor, tube to plug	1

PARTS INFORMATION

OPTIONAL HAND SHOWER ASSEMBLY

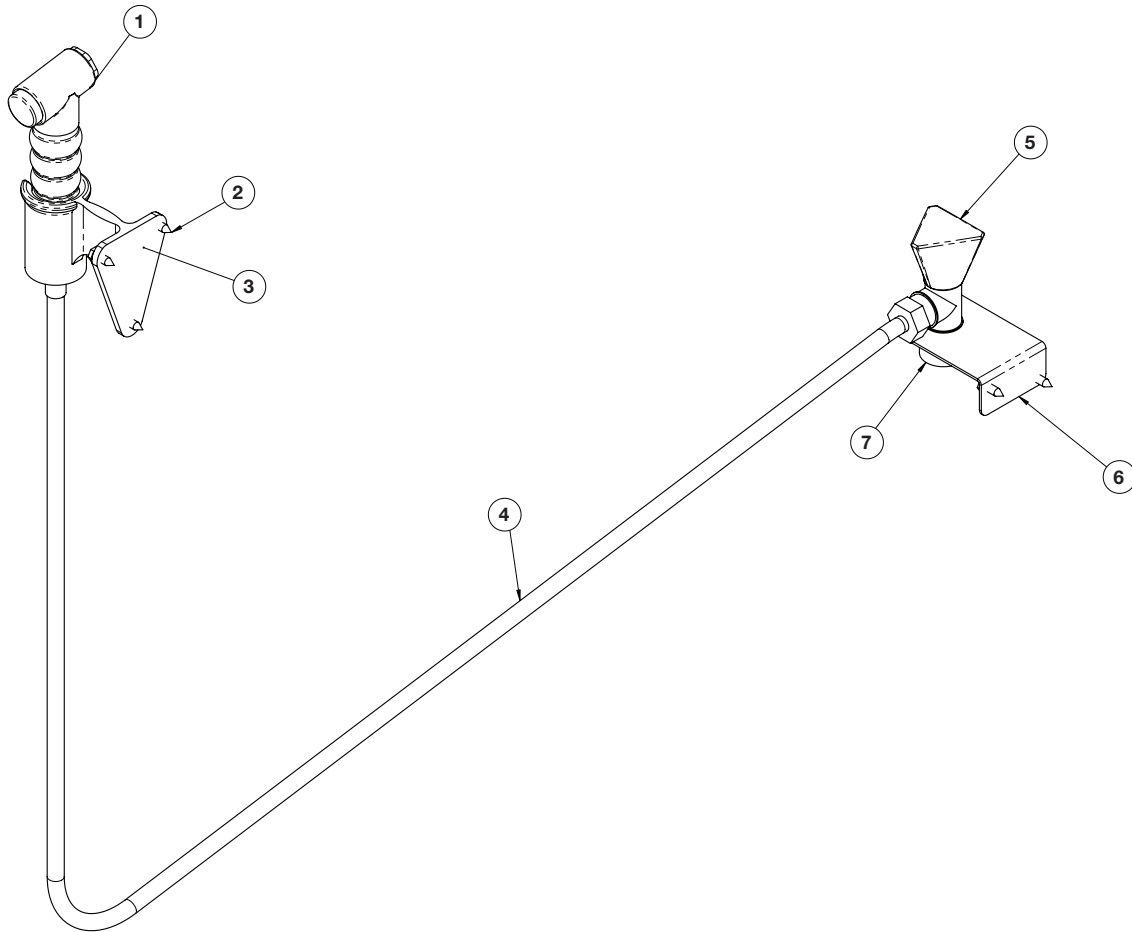

5014743

Item	Part	Description	Qty.
1	PB-29664	Plumbing, Hand Sprayer	1
2	SC-29871	Screw, #8 x 1/2" Hex Flg	1
3	HL-29741	Holder, Hand Sprayer	1
4	HO-29669	Hose, Hand Sprayer	1
5	VA-29646	Valve, Hand Sprayer Shut-Off	1
6	1012645	Bracket, Mount Shut-Off Valve	1
7	PB-35228	Plumbing, 3/4" GHT (M) to 1/2" NPT (F)	1

PARTS INFORMATION

ELECTRICAL ASSEMBLY - SIMPLE CONTROL - 208V 1PH & 240V 1PH

(5013817 shown)

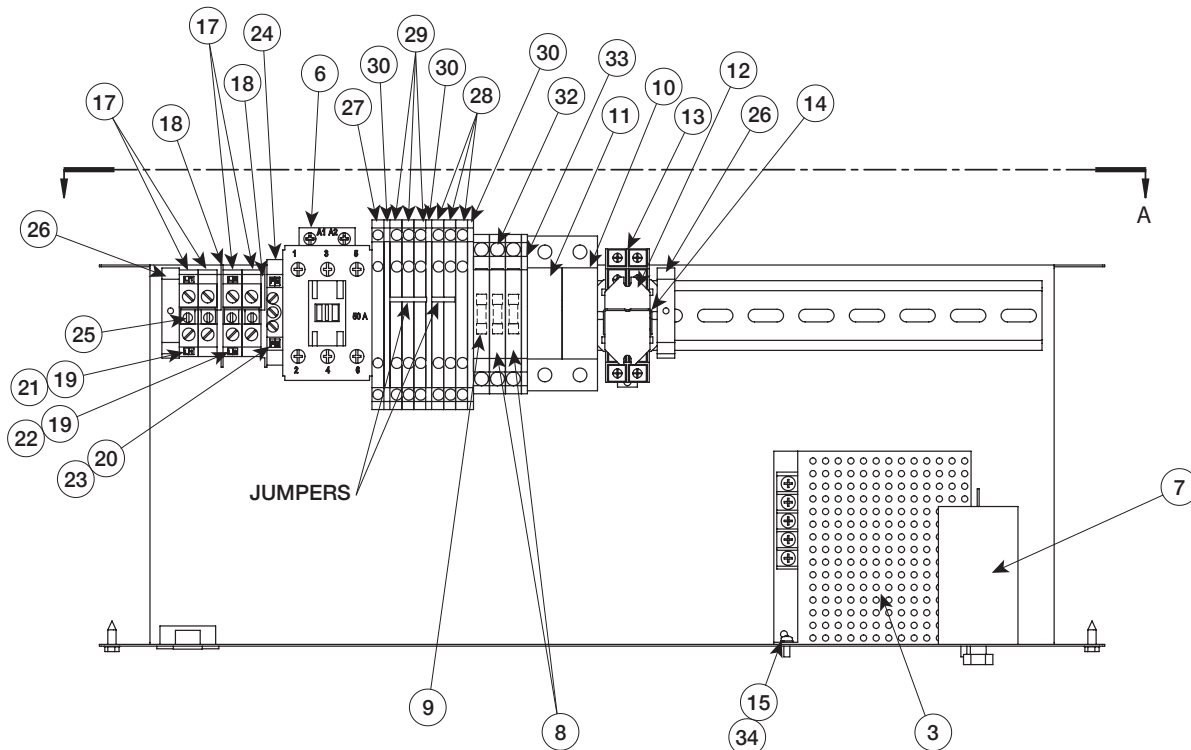
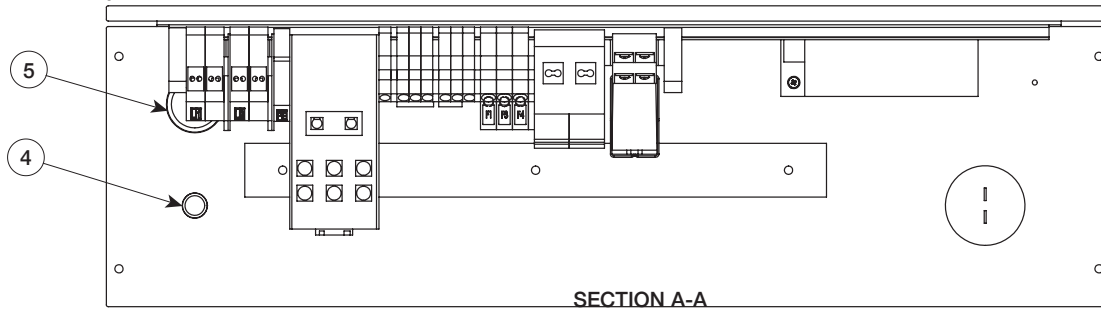

Item	Part	Description	Qty.
1*	5013818	Spot Assembly, Electronic Chassis Rail	1
2*	5015146	Assembly, Fan Tunnel	1
3	BA-36144	Board, Power Supply, 12V, 50W	1
4	BU-3006	1/2" Hole Bushing	1
5	BU-3378	1-1/8" Snap Bushing	1
6	CN-3731	Contactors, 50 AMP	1
7	CU-29666	Capacitor, 16uF	1
8	FU-33184	Fuse, 5 x 20mm, Slow Blo, 2 AMP, 250V	4
9	FU-33452	Fuse, Neozed, 6.3 AMP	2
10	FU-34771	Fuse Holder, 2 Bank	1
11	FU-35680	Fuse, 6.25 AMP	1
12	RL-33483	Relay, 240V LY1F	1
13	RL-34634	Universal Mounting Socket	1
14	RL-37266	Spring, Hold Down	1
15	SC-22268	Screw, M3 x 0.5 x 8mm Pan	2
16	SC-29871	Screw, #8 x 1/2" Hex FLG	4
17	TM-3779	Terminal Block	4

Item	Part	Description	Qty.
18	TM-3785	Partition	2
19	TM-3788	Terminals, Mark, L	4
20	TM-3789	Terminals, Mark, P	2
21	TM-3790	Terminals, Mark, 1	2
22	TM-3791	Terminals, Mark, 2	2
23	TM-3799	Terminals, Mark, E	2
24	TM-3932	Terminal, Ground	1
25	TM-33675	Jumper Strip	2
26	TM-34305	Terminal, Screwless End	2
27	TM-34306	Terminal, Ground, 6mm, Spring	1
28	TM-34307	Terminal, 6mm, Orange, Spring	3
29	TM-34308	Terminal, 6mm, Blue, Spring	3
30	TM-34309	Terminal, End Section, Spring	3
31*	TM-34310	Jumper Bar	1
32	TM-34311	Terminal, Fuse Holder, 8mm	3
33	TM-34315	Terminal, End Plate	1
34	WS-22299	Washer, Split Lock	2

*NOT SHOWN

PARTS INFORMATION

ELECTRICAL ASSEMBLY - SIMPLE CONTROL - 208-240V 3PH (5014568 shown)

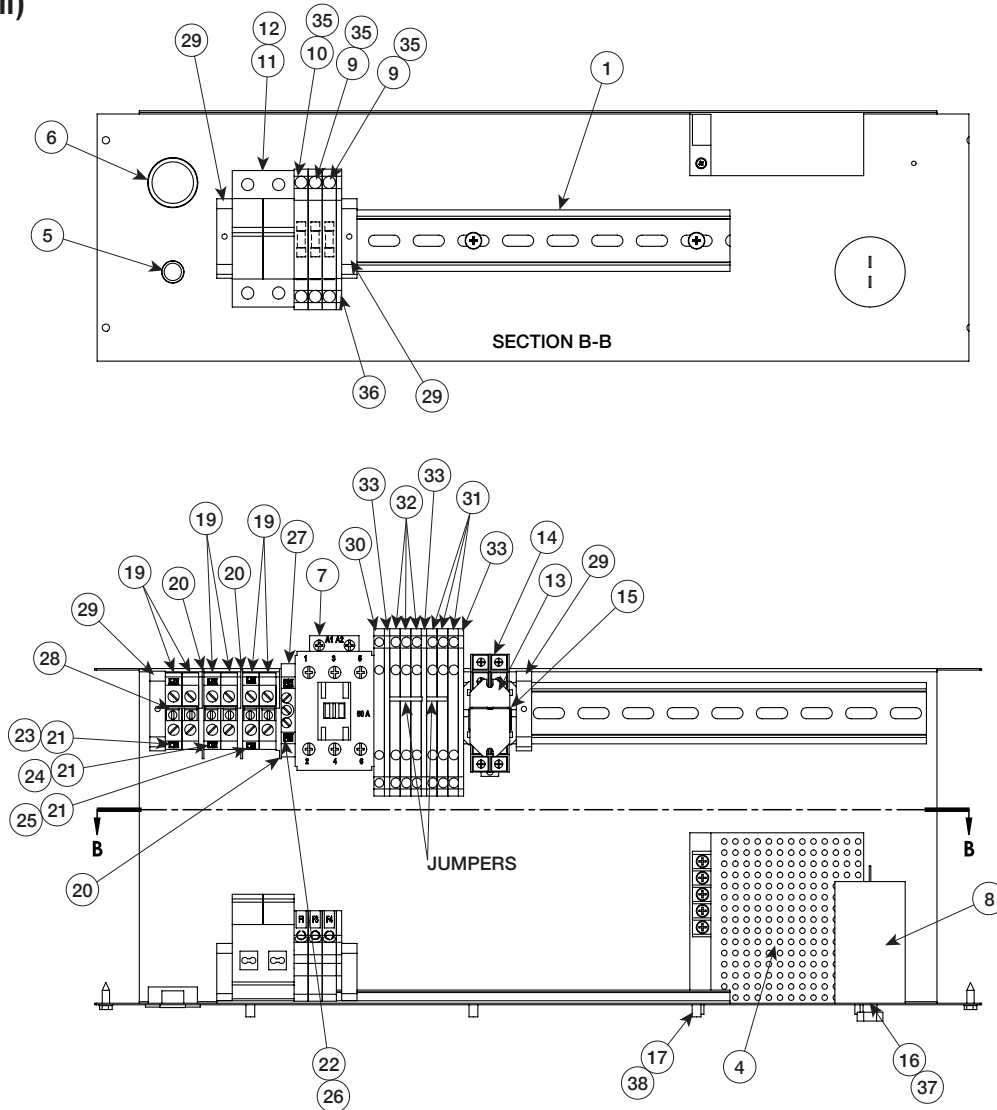

Item	Part	Description	Qty.	Item	Part	Description	Qty.
1	1009584	Din Rail 11-1/2"	1	20	TM-3785	Partition	3
2*	5013818	Spot Assembly, Electronic Chassis Rail	1	21	TM-3788	Terminals, Mark, L	6
3*	5015146	Assembly, Fan Tunnel	1	22	TM-3789	Terminals, Mark, P	2
4	BA-36144	Board, Power Supply, 12V, 50W	1	23	TM-3790	Terminals, mark, 1	2
5	BU-3006	1/2" Hole Bushing	1	24	TM-3791	Terminals, Mark, 2	2
6	BU-3378	1-1/8" Snap Bushing	1	25	TM-3792	Terminals, Mark, 3	2
7	CN-3731	Contact, 50 Amp	1	26	TM-3799	Terminals, Mark, E	2
8	CU-29666	Capacitor, 16uF	1	27	TM-3932	Terminal, Ground	1
9	FU-33184	Fuse, 5 x 20mm, Slow Blo, 2 Amp, 250V	4	28	TM-33675	Jumper Strip	3
10	FU-33452	Fuse, Neozed, 6.3 Amp	2	29	TM-34305	Terminal, Screwless End	4
11	FU-34771	Fuse Holder, 2 Bank	1	30	TM-34306	Terminal, Ground, 6mm, Spring	1
12	FU-35680	Fuse, 6.25 Amp	1	31	TM-34307	Terminal, 6mm, Orange, Spring	3
13	RL-33483	Relay, 240V LY1F	1	32	TM-34308	Terminal, 6mm, Blue, Spring	3
14	RL-34634	Universal Mounting Socket	1	33	TM-34309	Terminal, End Section, Spring	3
15*	RL-37266	Spring, Hold Down	4	34*	TM-34310	Jumper Bar	1
16	SC-22268	Screw, M3 x 0.5 x 8mm Pan	2	35	TM-34311	Terminal, Fuse Holder, 8mm	3
17	SC-22766	Screw, M5 x 0.8 x 10mm Pan	3	36	TM-34315	Terminal, End Plate	1
18*	SC-29871	Screw, #8 x 1/2" Hex Flange	4	37	WS-22299	Washer, Split Lock	2
19	TM-3779	Terminal Block	6	38	WS-22301	Washer, M5 Split Lock S/S 18-8	3

*NOT SHOWN

PARTS INFORMATION

ELECTRICAL ASSEMBLY - SIMPLE CONTROL - 380-415V 3PH (5014569 shown)

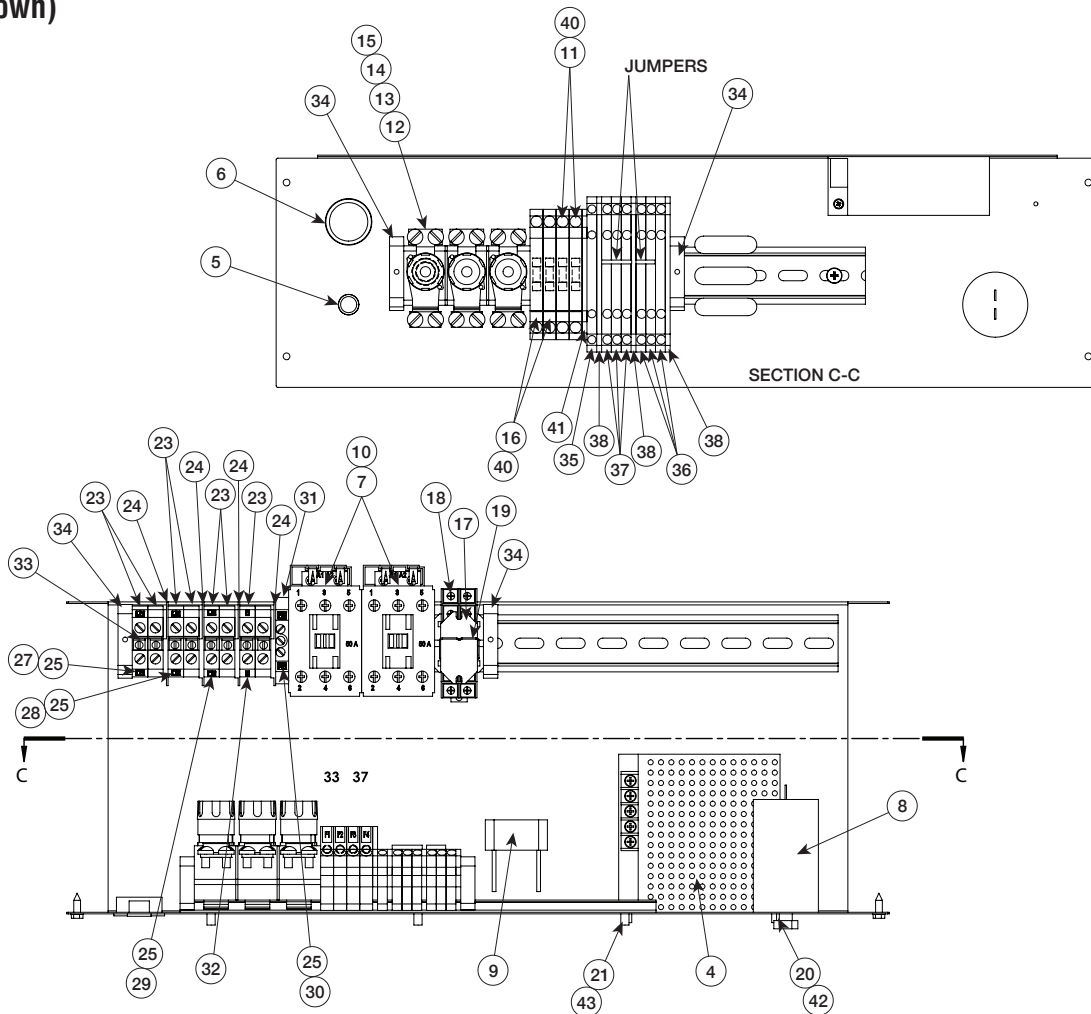

Item	Part	Description	Qty.	Item	Part	Description	Qty.
1*	1009584	Din Rail 11-1/2"	1	23	TM-3779	Terminal Block	8
2*	5013818	Spot Assembly, Electronic Chassis Rail	1	24	TM-3785	Partition	4
3*	5015146	Assembly, Fan Tunnel	1	25	TM-3788	Terminals, Mark, L	6
4	BA-36144	Board, Power Supply, 12V 50W	1	26	TM-3789	Terminals, Mark, P	2
5	BU-3006	1/2" Hole Bushing	1	27	TM-3790	Terminals, Mark, 1	2
6	BU-3378	1-1/8" Snap Bushing	1	28	TM-3791	Terminals, Mark, 2	2
7	CN-3731	Contactors, 50 AMP	2	29	TM-3792	Terminals, Mark, 3	2
8	CU-29666	Capacitor, 16uF	1	30	TM-3799	Terminals, Mark, E	2
9	FI-33989	Filter, RD-Module	3	31	TM-3932	Terminal, Ground	1
10	FI-33990	EMI Filter	2	32	TM-33479	Terminals, Mark, N	2
11	FU-33184	5 x 20mm, Slow Blo, 2 AMP, 250V	4	33	TM-33675	Jumper Strip	4
12	FU-33444	Fuse, D02 Neozed Base Snap-On	3	34	TM-34305	Terminal, Screwless End	4
13	FU-33445	Fuse, D02 Neozed Screw Cap	3	35	TM-34306	Terminal, Ground, 6mm, Spring	1
14	FU-33447	Fuse, D02 Neozed Gauge Ring 20A	3	36	TM-34307	Terminal, 6mm, Orange, Spring	3
15	FU-33450	Fuse, D02 Neozed 20A, Blue	3	37	TM-34308	Terminal, 6mm, Blue, Spring	3
16	FU-33452	Neozed, 6.3 AMP	4	38	TM-34309	Terminal, End Section, Spring	3
17	RL-33483	Relay, 240V LYIF	1	39*	TM-34310	Jumper Bar	1
18	RL-34634	Universal Mounting Socket	1	40	TM-34311	Terminal, Fuse Holder, 8mm	4
19	RL-37266	Spring, Hold Down	1	41	TM-34315	Terminal, End Plate	1
20	SC-22268	Screw, M3 x 0.5 x 8mm Pan	2	42	WS-22299	Washer, Split Lock	2
21	SC-22766	Screw, M5 X 0.8 X 10mm Pan	3	43	WS-22301	Washer, M5 Split Lock S/S 18-8	3
22*	SC-29871	Screw, #8 x 1/2" Hex Flange	4				

*NOT SHOWN

PARTS INFORMATION

ELECTRICAL ASSEMBLY - SIMPLE CONTROL - 220-240V 1PH

(5018177 shown)

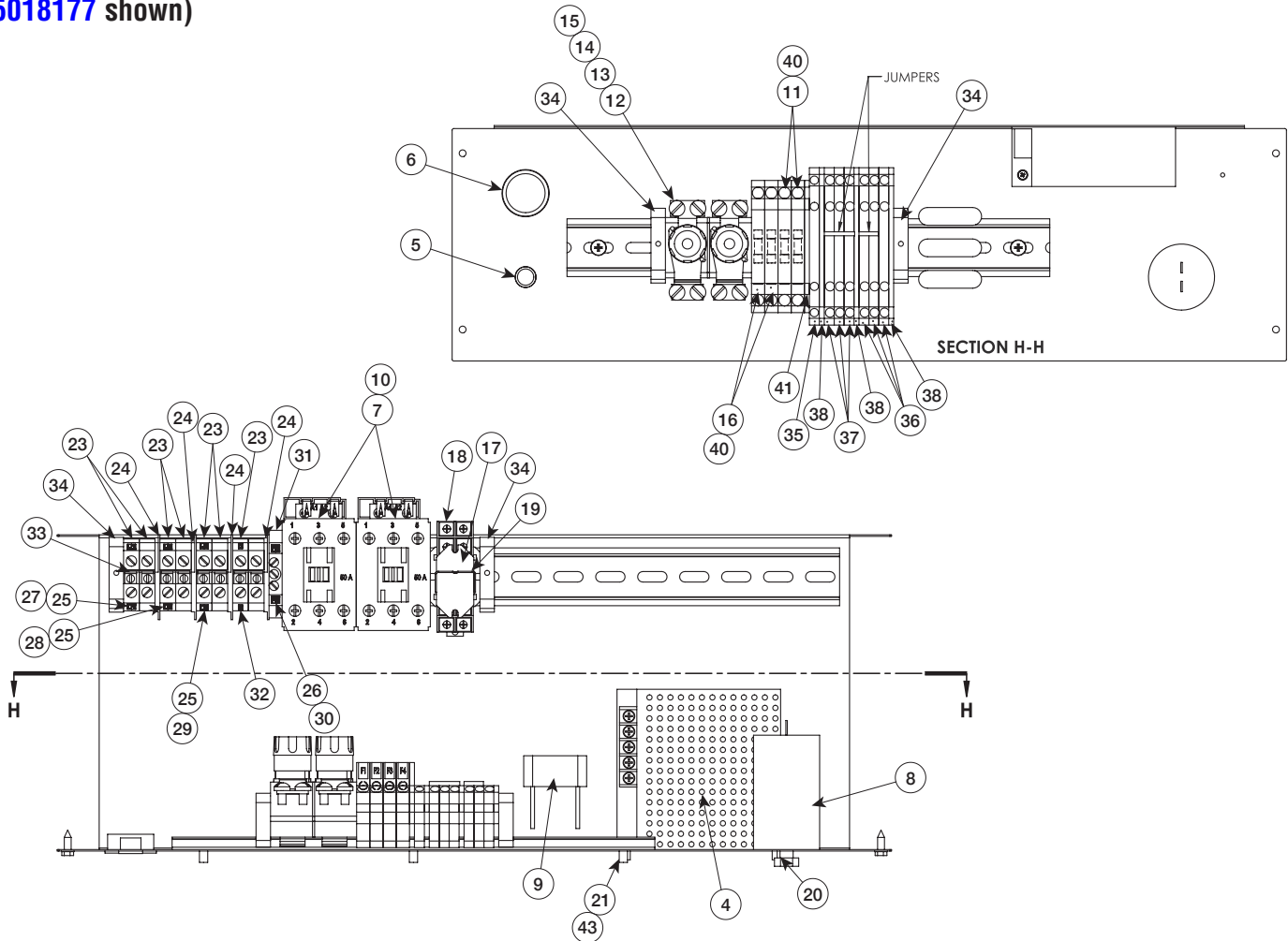

Item	Part	Description	Qty.
1*	1009584	Din Rail 11-1/2"	1
2*	5013818	Spot Assembly, Electronic Chassis Rail	1
3*	5015146	Assembly, Fan Tunnel	1
4	BA-36144	Board, Power Supply, 12V 50W	1
5	BU-3006	1/2" Hole Bushing	1
6	BU-3378	1-1/8" Snap Bushing	1
7	CN-3731	Contact, 50 AMP	2
8	CU-29666	Capacitor, 16uF	1
9	FI-33989	Filter, RD-Module	3
10	FI-33990	EMI Filter	2
11	FU-33184	5 x 20mm, Slow Blo, 2 AMP, 250V	4
12	FU-33444	Fuse, D02 Neozed Base Snap-On	2
13	FU-33445	Fuse, D02 Neozed Screw Cap	2
14	FU-33447	Fuse, D02 Neozed Gauge Ring 20A	2
15	FU-33450	Fuse, D02 Neozed 20A, Blue	2
16	FU-33452	Neozed, 6.3 AMP	4
17	RL-33483	Relay, 240V LYIF	1
18	RL-34634	Universal Mounting Socket	1
19	RL-37266	Spring, Hold Down	1
20	SC-22268	Screw, M3 x 0.5 x 8mm Pan	2
21	SC-22766	Screw, M5 x 0.8 x 10mm Pan	3
22*	SC-29871	Screw, #8 x 1/2" Hex Flange	4

Item	Part	Description	Qty.
23	TM-3779	Terminal Block	8
24	TM-3785	Partition	4
25	TM-3788	Terminals, Mark, L	6
26	TM-3789	Terminals, Mark, P	2
27	TM-3790	Terminals, Mark, 1	2
28	TM-3791	Terminals, Mark, 2	2
29	TM-3792	Terminals, Mark, 3	2
30	TM-3799	Terminals, Mark, E	2
31	TM-3932	Terminal, Ground	1
32	TM-33479	Terminals, Mark, N	2
33	TM-33675	Jumper Strip	4
34	TM-34305	Terminal, Screwless End	4
35	TM-34306	Terminal, Ground, 6mm, Spring	1
36	TM-34307	Terminal, 6mm, Orange, Spring	3
37	TM-34308	Terminal, 6mm, Blue, Spring	3
38	TM-34309	Terminal, End Section, Spring	3
39*	TM-34310	Jumper Bar	1
40	TM-34311	Terminal, Fuse Holder, 8mm	4
41	TM-34315	Terminal, End Plate	1
42	WS-22299	Washer, Split Lock	2
43	WS-22301	Washer, M5 Split Lock S/S 18-8	3

*NOT SHOWN

PARTS INFORMATION

ELECTRICAL ASSEMBLY - EXPRESS TOUCH - 208V 1PH & 240V 1PH (5014731 shown)

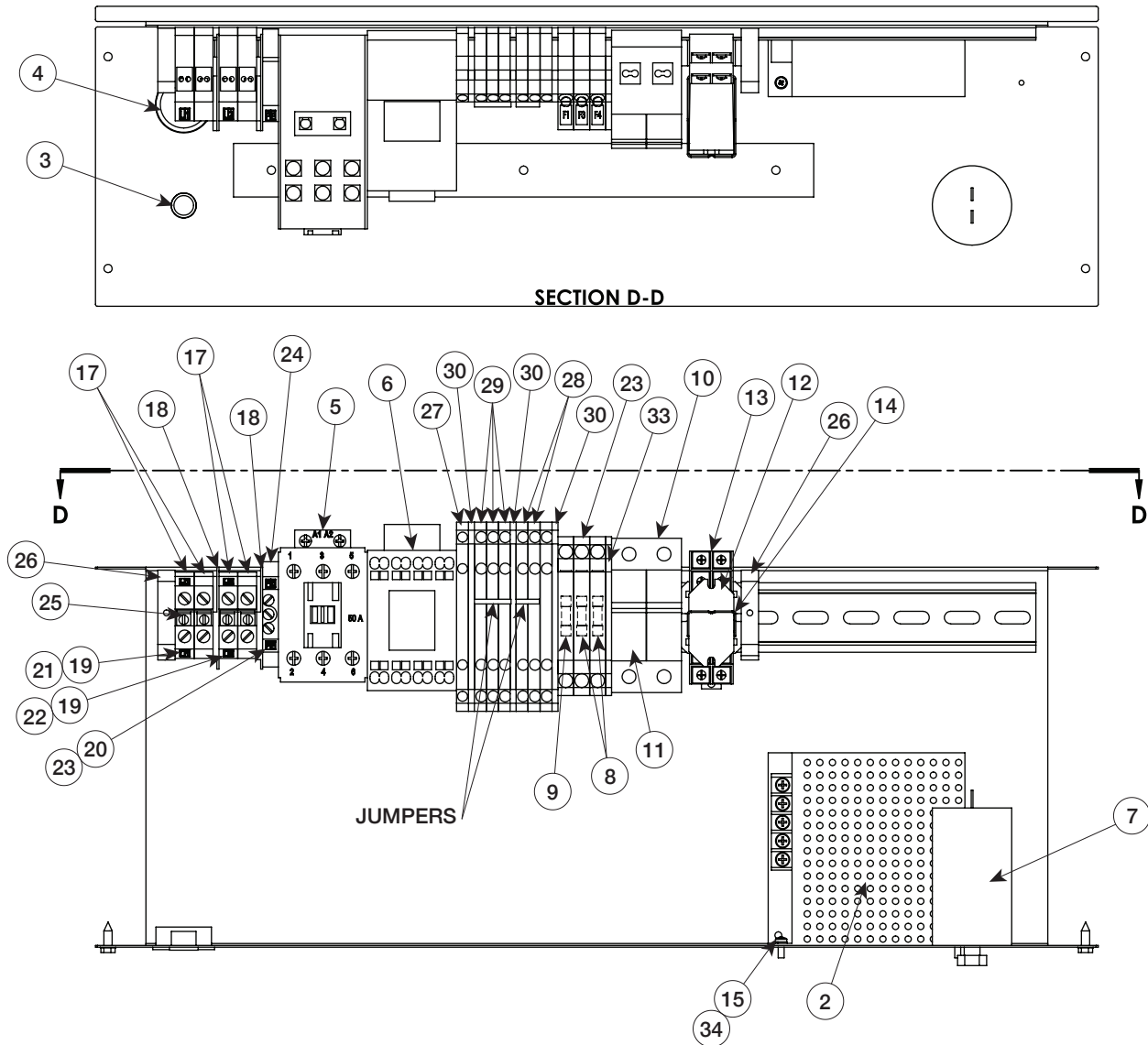

Item	Part	Description	Qty.	Item	Part	Description	Qty.
1*	5015146	Assembly, Fan Tunnel	1	18	TM-3785	Partition	2
2	BA-36144	Board, Power Supply, 12V 50W	1	19	TM-3788	Terminals, Mark, L	4
3	BU-3006	1/2" Hole Bushing	1	20	TM-3789	Terminals, Mark, P	2
4	BU-3378	1-1/8" Snap Bushing	1	21	TM-3790	Terminals, Mark, 1	2
5	CN-3731	Contactora, 50 AMP	1	22	TM-3791	Terminals, Mark, 2	2
6	CN-34304	Contactora, 240V, 25 AMP	1	23	TM-3799	Terminals, Mark, E	2
7	CU-29666	Capacitor, 16uF	1	24	TM-3932	Terminal, Ground	1
8	FU-33184	5 x 20mm, Slow Blo, 2 AMP, 250V	4	25	TM-33675	Jumper Strip	2
9	FU-33452	Neozed, 6.3 AMP	2	26	TM-34305	Terminal, Screwless End	2
10	FU-34771	Fuse Holder, 2 Bank	1	27	TM-34306	Terminal, Ground, 6mm, Spring	1
11	FU-35680	Fuse, 6.25 AMP	1	28	TM-34307	Terminal, 6mm, Orange, Spring	3
12	RL-33483	Relay, 240V LY1F	1	29	TM-34308	Terminal, 6mm, Blue, Spring	3
13	RL-34634	Universal Mounting Socket	1	30	TM-34309	Terminal, End Section, Spring	3
14	RL-37266	Spring, Hold Down	1	31*	TM-34310	Jumper Bar	1
15	SC-22268	Screw, M3 x 0.5 x 8mm Pan	2	32*	TM-34311	Terminal, Fuse Holder, 8mm	3
16*	SC-29871	Screw, #8 1/2" Hex Flange	4	33	TM-34315	Terminal, End Plate	1
17	TM-3779	Terminal Block	4	34	WS-22299	Washer, Split Lock	2

*NOT SHOWN

PARTS INFORMATION

ELECTRICAL ASSEMBLY - EXPRESS TOUCH - 208-240V 3PH (5014732 shown)

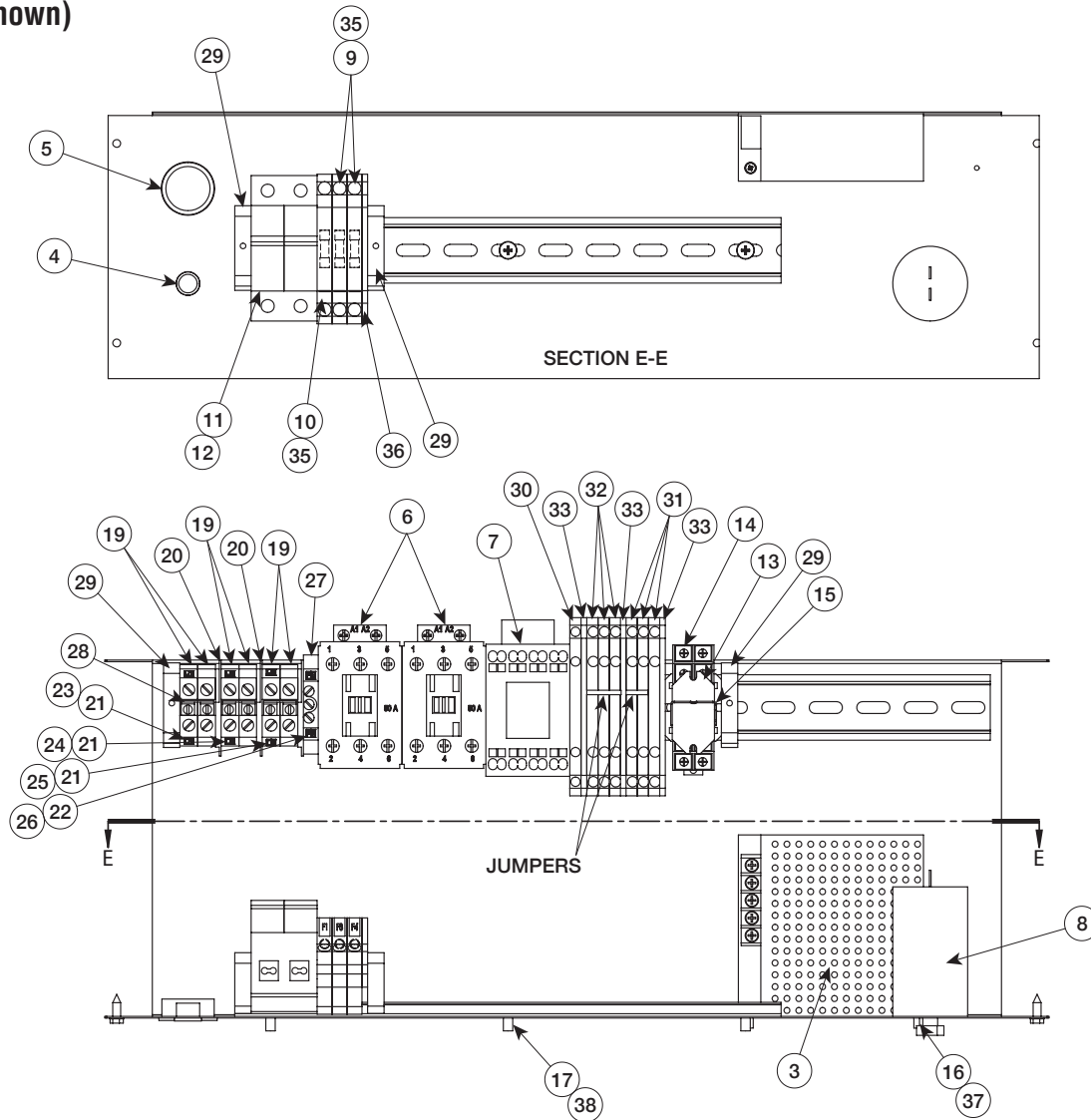

Item	Part	Description	Qty.	Item	Part	Description	Qty.
1*	1009584	Din Rail 11-1/2"	1	20	TM-3785	Partition	3
2*	5015146	Assembly, Fan Tunnel	1	21	TM-3788	Terminals, Mark, L	6
3	BA-36144	Board, Power Supply, 12V 50W	1	22	TM-3789	Terminals, Mark, P	2
4	BU-3006	1/2" Hole Bushing	1	23	TM-3790	Terminals, Mark, 1	2
5	BU-3378	1-1/8" Snap Bushing	1	24	TM-3791	Terminals, Mark, 2	2
6	CN-3731	Contactors, 50 AMP	2	25	TM-3792	Terminals, Mark, 3	2
7	CN-34304	Contactors, 240V, 25 AMP	1	26	TM-3799	Terminals, Mark, E	2
8	CU-29666	Capacitor, 16uF	1	27	TM-3932	Terminal, Ground	1
9	FU-33184	5 x 20mm, Slow Blo, 2 AMP, 250V	4	28	TM-33675	Jumper Strip	3
10	FU-33452	Neozed, 6.3 AMP	2	29	TM-34305	Terminal, Screwless End	4
11	FU-34771	Fuse Holder, 2 Bank	1	30	TM-34306	Terminal, Ground, 6mm, Spring	1
12	FU-35680	Fuse, 6.25 AMP	1	31	TM-34307	Terminal, 6mm, Orange, Spring	3
13	RL-33483	Relay, 240V LY1F	1	32	TM-34308	Terminal, 6mm, Blue, Spring	3
14	RL-34634	Universal Mounting Socket	1	33	TM-34309	Terminal, End Section, Spring	3
15	RL-37266	Spring, Hold Down	1	34*	TM-34310	Jumper Bar	1
16	SC-22268	Screw, M3 x 0.5 x 8mm Pan	2	35	TM-34311	Terminal, Fuse Holder, 8mm	3
17	SC-22766	Screw, M5 x 0.8 x 10mm Pan	3	36	TM-34315	Terminal, End Plate	1
18*	SC-29871	Screw, #8 x 1/2" Hex Flange	4	37	WS-22299	Washer, Split Lock	2
19	TM-3779	Terminal Block	6	38	WS-22301	Washer, M5 Split Lock S/S 18-8	3

*NOT SHOWN

PARTS INFORMATION

ELECTRICAL ASSEMBLY - EXPRESS TOUCH - 380-415V 3PH (5014733 shown)

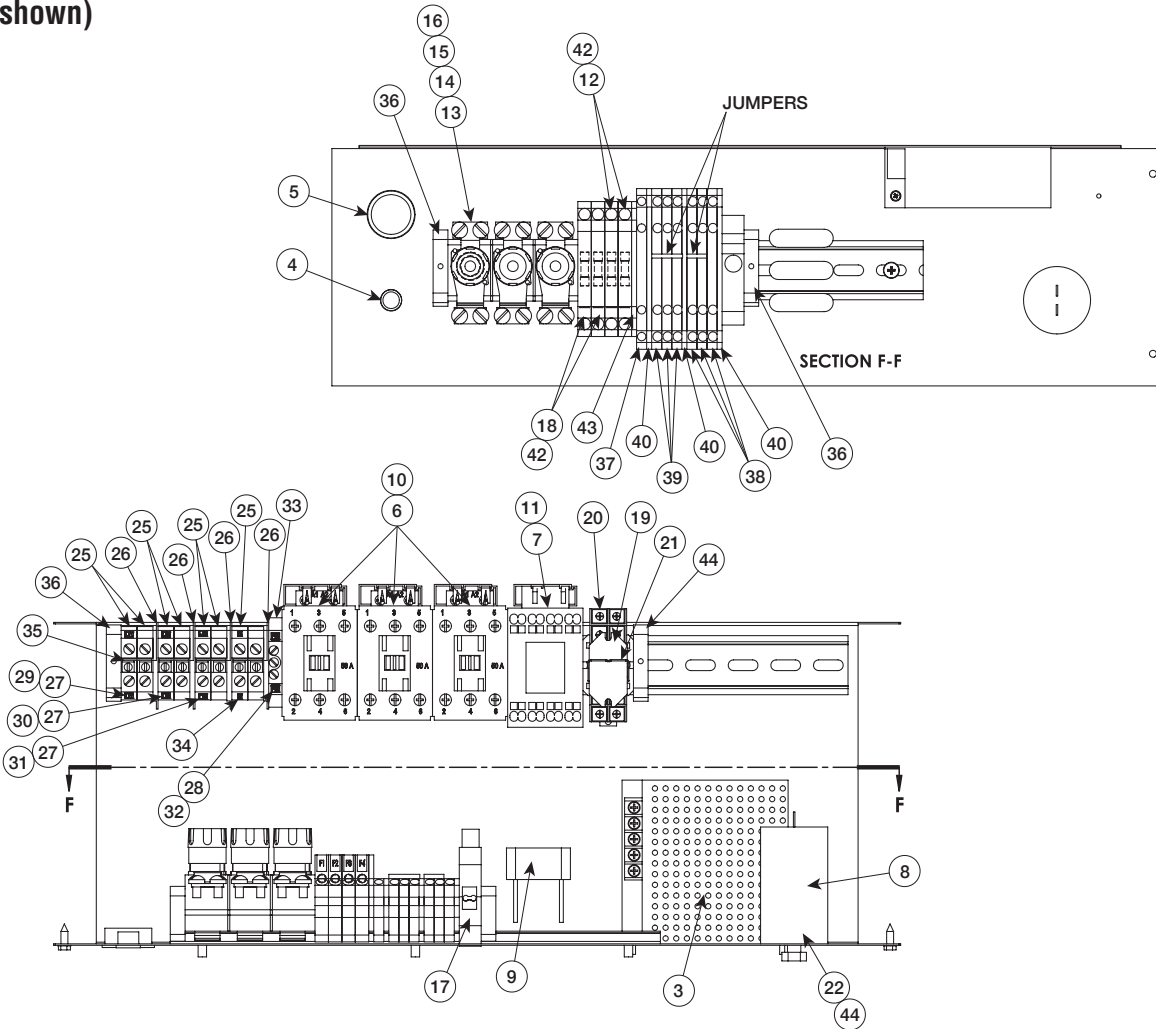

Item	Part	Description	Qty.	Item	Part	Description	Qty.
1*	1009584	Din Rail 11-1/2"	1	24*	SC-29871	Screw, #8 x 1/2" Hex Flange	4
2*	5015146	Assembly, Fan Tunnel	1	25	TM-3779	Terminal Block	8
3	BA-36144	Board, Power Supply, 12V 50W	1	26	TM-3785	Partition	4
4	BU-3006	1/2" Hole Bushing	1	27	TM-3788	Terminals, Mark, L	6
5	BU-3378	1-1/8" Snap Bushing	1	28	TM-3789	Terminals, Mark, P	2
6	CN-3731	Contactors, 50 AMP	3	29	TM-3790	Terminals, Mark, 1	2
7	CN-34304	Contactors, 240V, 25 AMP	1	30	TM-3791	Terminals, Mark, 2	2
8	CU-29666	Capacitor, 16uF	1	31	TM-3792	Terminals, Mark, 3	2
9	FI-33989	Filter, RC-Module	3	32	TM-3799	Terminals, Mark, E	2
10	FI-33990	EMI Filter	3	33	TM-3932	Terminal, Ground	1
11	FI-34492	Filter, For Spring Clamp	1	34	TM-33479	Terminals, Mark, N	2
12	FU-33184	5 x 20mm, Slow Blo, 2 AMP, 250V	4	35	TM-33675	Jumper Strip	4
13	FU-33444	Fuse, D02 Neozed Base Snap-On	3	36	TM-34305	Terminal, Screwless End	4
14	FU-33445	Fuse, D02 Neozed Screw Cap	3	37	TM-34306	Terminal, Ground, 6mm, Spring	1
15	FU-33447	Fuse, D02 Neozed Gauge Ring 20A	3	38	TM-34307	Terminal, 6mm, Orange, Spring	3
16	FU-33450	Fuse, D02 Neozed 20A, Blue	3	39	TM-34308	Terminal, 6mm, Blue, Spring	3
17	FU-33451	Fuse, Terminal, 6.3 AMP	1	40	TM-34309	Terminal, End Section, Spring	3
18	FU-33452	Neozed, 6.3 AMP	4	41*	TM-34310	Jumper Bar	1
19	RL-33483	Relay, 240V LY1F	1	42	TM-34311	Terminal, Fuse Holder, 8mm	4
20	RL-34634	Universal Mounting Socket	1	43	TM-34315	Terminal, End Plate	1
21	RL-37266	Spring, Hold Down	1	44	WS-22299	Washer, Split Lock	2
22	SC-22268	Screw, M3 x 0.5 x 8mm Pan	2	45	WS-22301	Washer, M5 Split Lock S/S 18-8	3
23*	SC-22766	Screw, M5 x 0.8 x 10mm Pan	3				

*NOT SHOWN

PARTS INFORMATION

ELECTRICAL ASSEMBLY - EXPRESS TOUCH - 220-240V 1PH (5018165 shown)

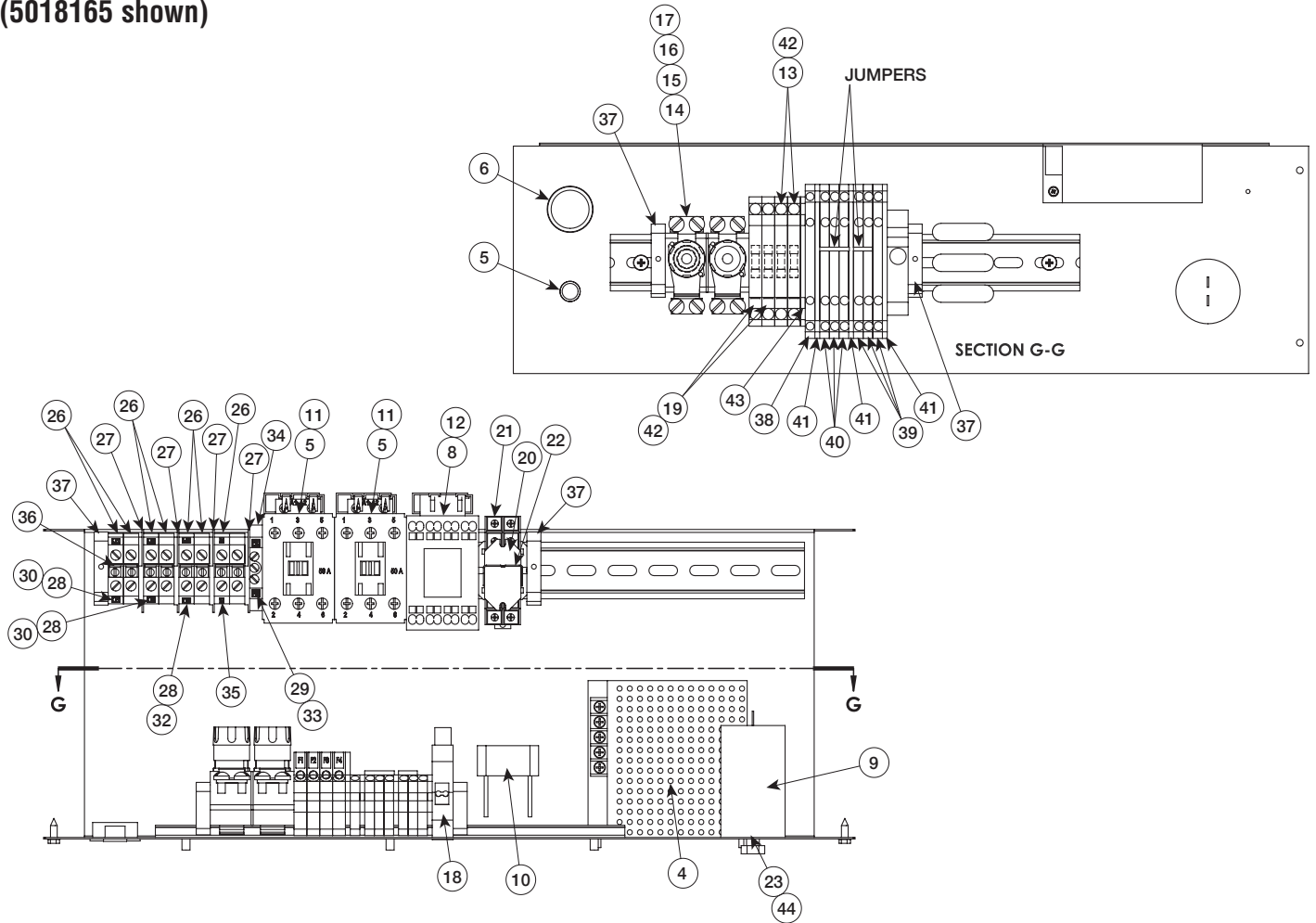

Item	Part	Description	Qty.	Item	Part	Description	Qty.
1*	1009584	Din Rail 11-1/2"	1	24*	SC-22766	Screw, M5 x 0.8 x 10mm Pan	3
2*	5013818	Spot Assembly, Electrical Chassis Rail	1	25*	SC-29871	Screw, #8 x 1/2" Hex Flange	4
3*	5015146	Assembly, Fan Tunnel	1	26	TM-3779	Terminal Block	8
4	BA-36144	Board, Power Supply, 12V 50W	1	27	TM-3785	Partition	4
5	BU-3006	1/2" Hole Bushing	1	28	TM-3788	Terminals, Mark, L	6
6	BU-3378	1-1/8" Snap Bushing	1	29	TM-3789	Terminals, Mark, P	2
7	CN-3731	Contactors, 50 AMP	2	30	TM-3790	Terminals, Mark, 1	2
8	CN-34304	Contactors, 240V, 25 AMP	1	31	TM-3791	Terminals, Mark, 2	2
9	CU-29666	Capacitor, 16uF	1	32	TM-3792	Terminals, Mark, 3	2
10	FI-33989	Filter, RC-Module	3	33	TM-3799	Terminals, Mark, E	2
11	FI-33990	EMI Filter	2	34	TM-3932	Terminal, Ground	1
12	FI-34492	Filter, For Spring Clamp	1	35	TM-33479	Terminals, Mark, N	2
13	FU-33184	5 x 20mm, Slow Blo, 2 AMP, 250V	4	36	TM-33675	Jumper Strip	4
14	FU-33444	Fuse, DO2 Neozed Base Snap-On	2	37	TM-34305	Terminal, Screwless End	4
15	FU-33445	Fuse, DO2 Neozed Screw Cap	2	38	TM-34306	Terminal, Ground, 6mm, Spring	1
16	FU-33447	Fuse, DO2 Neozed Gauge Ring 20A	2	39	TM-34307	Terminal, 6mm, Orange, Spring	3
17	FU-33450	Fuse, DO2 Neozed 20A, Blue	2	40	TM-34308	Terminal, 6mm, Blue, Spring	3
18	FU-33451	Fuse, Terminal, 6.3 AMP	1	41	TM-34309	Terminal, End Section, Spring	3
19	FU-33452	Neozed, 6.3 AMP	4	42	TM-34311	Terminal, Fuse Holder, 8mm	4
20	RL-33483	Relay, 240V LY1F	1	43	TM-34315	Terminal, End Plate	1
21	RL-34634	Universal Mounting Socket	1	44	WS-22299	Washer, Split Lock	2
22	RL-37266	Spring, Hold Down	1	45*	WS-22301	Washer, M5 Split Lock S/S 18-8	3
23	SC-22268	Screw, M3 x 0.5 x 8mm Pan	2	46	TM-34310	Jumper Bar	1

*NOT SHOWN

PARTS INFORMATION

VENTLESS HOOD ASSEMBLY - FRONT AND SIDE VIEW

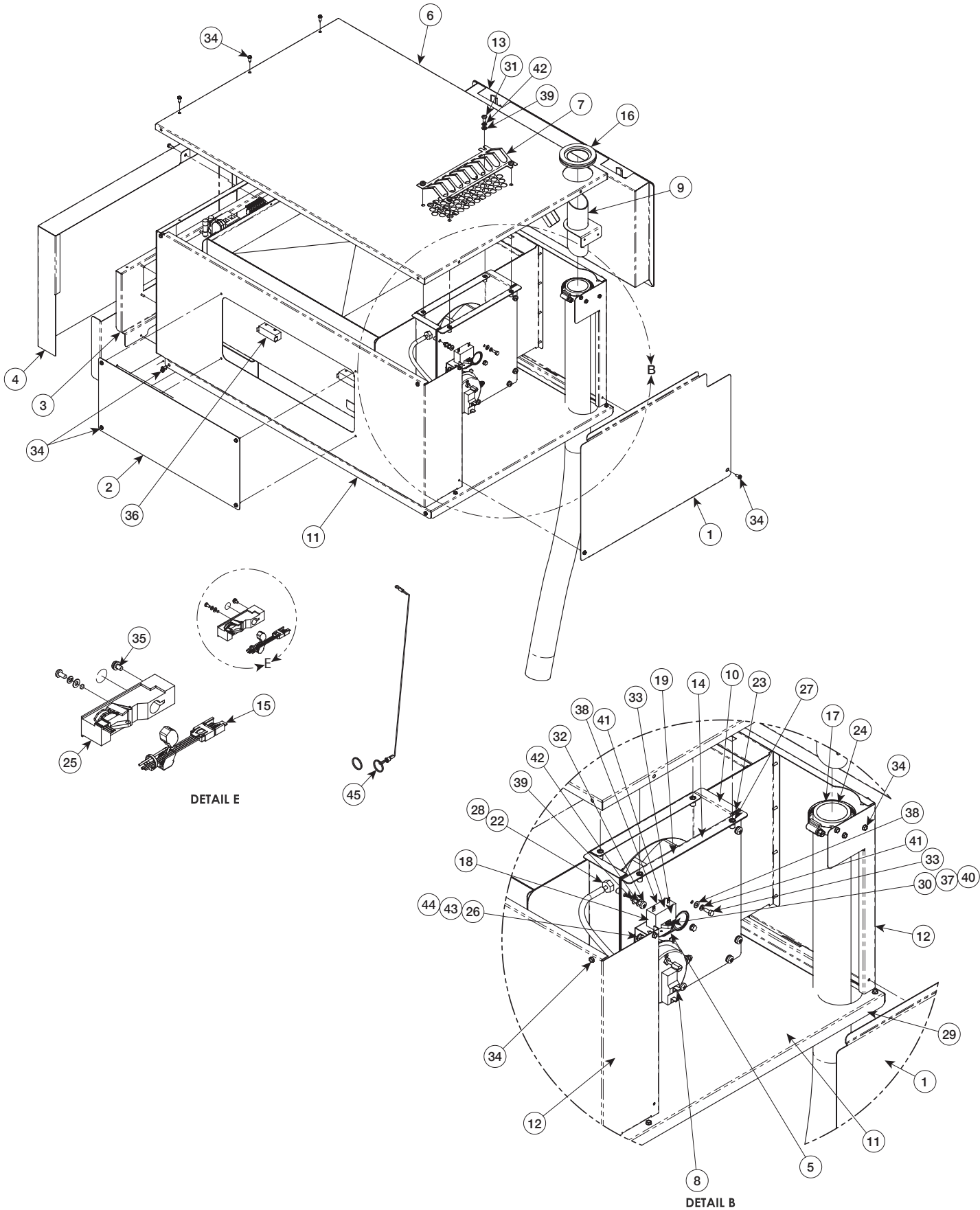

PARTS INFORMATION

VENTLESS HOOD ASSEMBLY - SIDE AND REAR VIEW

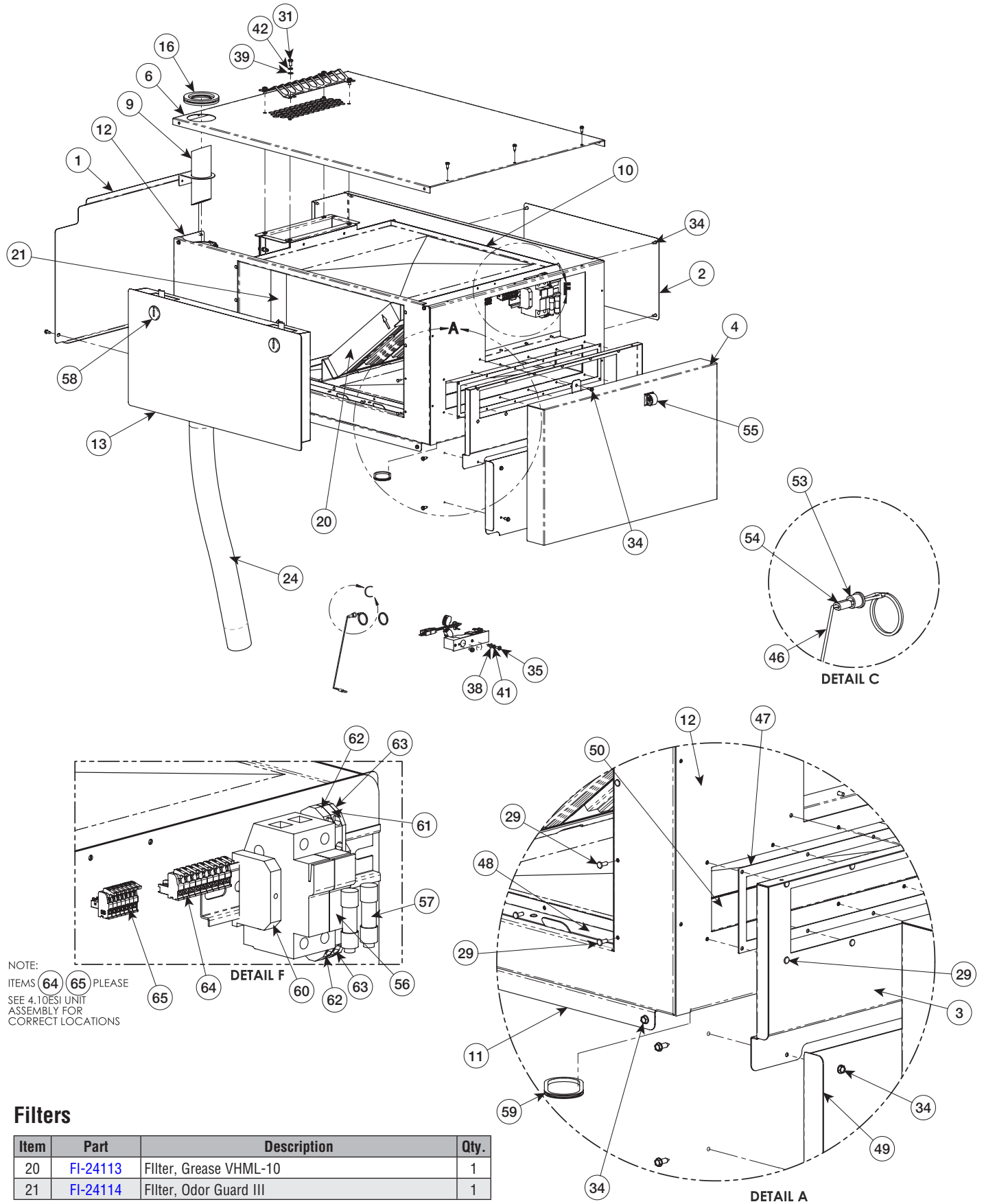

NOTE:
ITEMS 64 65 PLEASE
SEE 4.10ESI UNIT
ASSEMBLY FOR
CORRECT LOCATIONS

Filters

Item	Part	Description	Qty.
20	FI-24113	Filter, Grease VHML-10	1
21	FI-24114	Filter, Odor Guard III	1

PARTS INFORMATION

VENTLESS HOOD ASSEMBLY - 67751

Item	Part	Description	Qty.
1	1013195	Cover, Back	1
2	1013196	Cover, Sensor Stainless Steel	1
	PE-35548	Cover, Sensor Black	1
	PE-35549	Cover, Sensor Burgundy	1
	PE-35550	Cover, Sensor Red	1
	PE-35551	Cover, Sensor White	1
	PE-35552	Cover, Sensor Brown	1
	PE-35553	Cover, Sensor Custom	1
3	1013223	Snorkel, Back	1
4	1013224	Snorkel, Front	1
5	1013372	Bracket, Capacitor	1
6	1017565	Enclosure, Top, Stainless Steel	1
	PE-38009	Enclosure, Top, Black	1
	PE-38010	Enclosure, Top, Burgundy	1
	PE-38011	Enclosure, Top, Red	1
	PE-38012	Enclosure, Top, White	1
	PE-38013	Enclosure, Top, Brown	1
	PE-38014	Enclosure, Top, Custom	1
7	1017566	Guard, Exhaust	1
8	5014331	Calibrated Pressure Switch	1
9	5014726	Weld Assembly, Vent Tube	1
10	5014923	Inner Tube	1
11	5014968	Enclosure, Assembly Base, Stainless Steel	1
	5015564	Enclosure, Assembly Base, Black	1
	5015565	Enclosure, Assembly Base, Burgundy	1
	5015566	Enclosure, Assembly Base, Custom	1
	5015832	Enclosure, Assembly Base, Red	1
	5015833	Enclosure, Assembly Base, White	1
	5015834	Enclosure, Assembly Base, Brown	1
12	5014969	Enclosure, Spotweld, Stainless Steel	1
	PE-35626	Enclosure, Spotweld, Black	1
	PE-35627	Enclosure, Spotweld, Burgundy	1
	PE-35628	Enclosure, Spotweld, Red	1
	PE-35629	Enclosure, Spotweld, White	1
	PE-35630	Enclosure, Spotweld, Brown	1
	PE-35631	Enclosure, Spotweld, Custom	1
13	5014975	Cover, Access, Spotweld Stainless Steel	1
	PE-35632	Cover, Access, Spotweld Black	1
	PE-35633	Cover, Access, Spotweld Burgundy	1
	PE-35634	Cover, Access, Spotweld Red	1
	PE-35635	Cover, Access, Spotweld White	1
	PE-35636	Cover, Access, Spotweld Brown	1
	PE-35637	Cover, Access, Spotweld Custom	1
14	5015121	Assembly, Motor, Panel	1
15	5015598	Lock, Soldered, Rahrback	1
16	BU-28391	Bushing, Socket, Membrane	1
17	CL-22234	Clamp, Worm Gear, 40-60, Hose	1
18	CU-38016	Capacitor, Fan, 2uF, 450V AC	1

Item	Part	Description	Qty.
19	FA-37258	Fan, AC, Backward Curved	1
20	FI-24113	Filter, Grease VHML-10	1
21	FI-24114	Filter, Odor Guard III	1
22	FT-38065	Adaptor, Male, 3/16 x 1/4 NPT	1
23	GS-2019	Gasket, 1/2", Panel, Self Adhesive, 2.75' LG	1
24	HO-29435	Hose, 1-5/8" ID, 36" LG	1
25	LK-34292	Lock, Rahrback GMBH	1
26	NU-2296	Nut, Hex #8-32	3
27	NU-23909	Nut, Hex Insert M5	2
28	NU-38064	Locknut, 1/4 NPT, Nylon, Black	1
29	RI-27108	Rivet, Sealed	51
30	SC-22268	Screw, M3 x 0.5 x 8mm Pan	1
31	SC-22766	Screw, M5 x 0.8 x 10mm Pan	5
32	SC-22779	M5-0.8 x 20mm, Philips Pan Head, M/S	7
33	SC-23664	Screw M4 x 10mm Hex Head Trim	4
34	SC-29871	Screw, #8 x 1/2" Hex Flange	36
35	SC-34729	Screw, M4 x 0.7 x 8mm Pan	2
36	SW-35056	Switch, 5A 125-250V AC, 1/10 HP	2
37	WS-22293	Washer, Flat	1
38	WS-22294	Washer, Flat M4 18-8 S/S	6
39	WS-22295	Washer, Flat M5 S/S	11
40	WS-22299	Washer, Split Lock	1
41	WS-22300	Washer, Split Lock	6
42	WS-22301	Washer, M5 Split Lock S/S 18-8	11
43	WS-23424	Washer, Flat, #8, 18-8 SST	3
44	WS-27045	Washer, #8, Lock Washer	3
45	PL-28413	Pull, Key Ring, 3/4" Manual	2
46*	1011021	Cable, VHES	1
47*	1013225	Spacer, Tunnel	1
48*	1013412	Tabs, Closure	1
49*	1013511	Snorkel, Back, Lower	1
50*	5015245	Tunnel Spotweld	1
51*	5015613	Clip, Filter, Assembly	1
52*	BU-3008	3/4" White Snap Bushing	1
53*	BU-3009	Bushing, Snap, 5/16"	1
54*	CL-28849	Clip, Crimp for 1/16" Wire Cable	2
55*	CM-3585	Self Adhesive Wire Clamp	1
56*	FU-34771	Fuse Holder, 2 Bank	1
57*	FU-34784	Fuse, 5 AMP	2
58*	LT-25513	Latch, Pawl/Cain	2
59*	SL-3836	Sleeve, Grommet Edging	1
60*	TM-34305	Terminal, Screwless End	2
61*	TM-34307	Terminal, 6mm, Orange, Spring	1
62*	TM-34308	Terminal, 6mm, Blue, Spring	1
63*	TM-34309	Terminal, End Section, Spring	1
64*	TM-34801	Terminal, 5mm Pluggable, 9 Pole	1
65*	TM-34931	Terminal, 3.5mm Pluggable, 7 Pole	1
66*	TU-24183	Tubings, 3/16 ID, 14" LG	1

*NOT SHOWN

WIRING DIAGRAMS

Always refer to the wire diagram(s) included with the unit for most current version.

208-240V, 60Hz, 1Ph
77391..... F-2

208-240V, 60Hz, 3Ph
77421 F-12

380-415V, 50Hz, 3Ph
77420..... F-24

Return to Main Table of Contents ii

WIRING DIAGRAMS

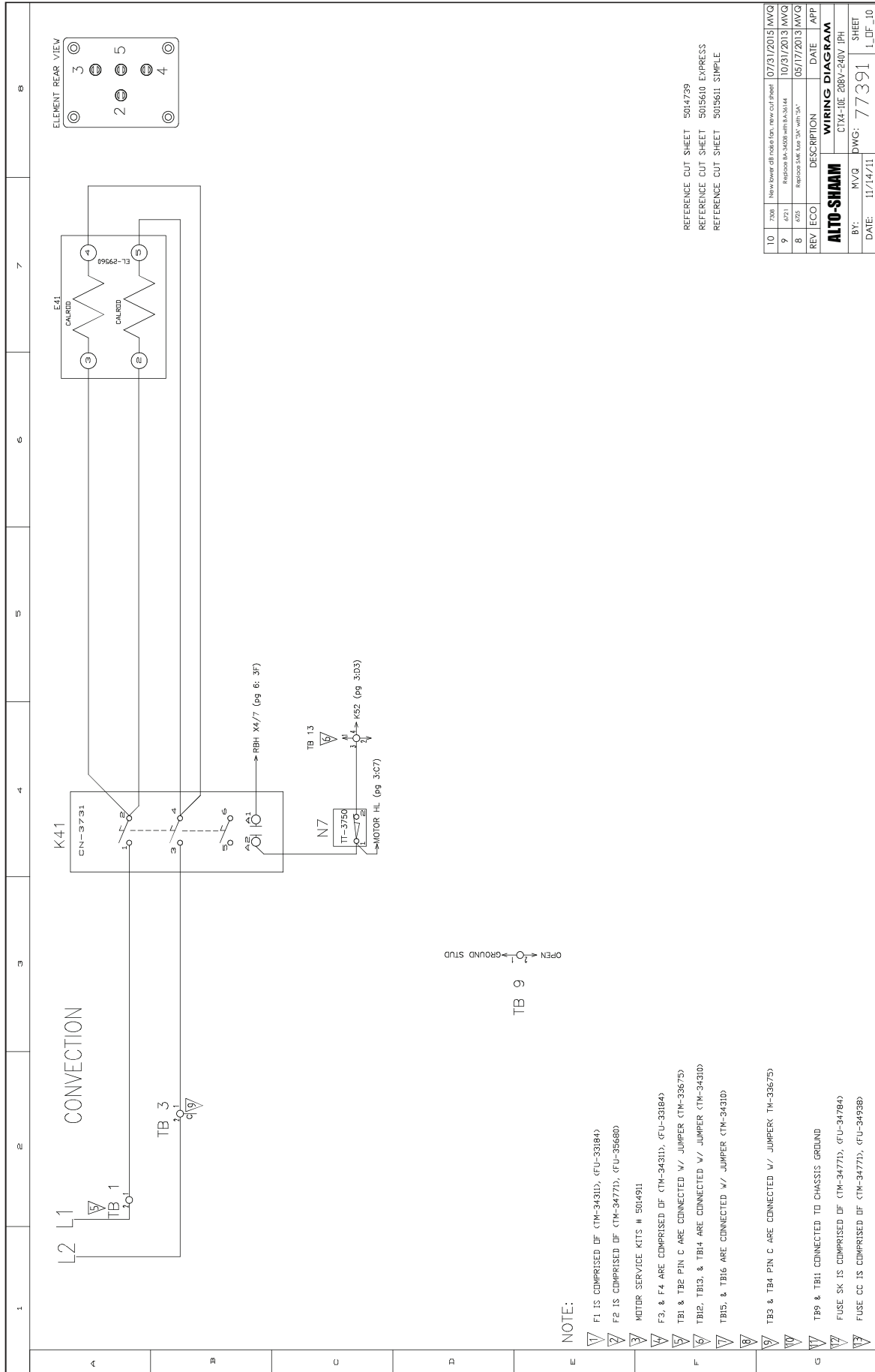

REFERENCE CUT SHEET 5014739
 REFERENCE CUT SHEET 5015610 EXPRESS
 REFERENCE CUT SHEET 5015611 SIMPLE

10	7388	New Power Off (NPO) (Rev. cut sheet)	07/31/2015	MVQ
9	4721	Revised M3-3608 with B.A.S. (4)	10/31/2013	MVQ
8	4725	Revised M3-3608 with 'SK' with 'SK'	05/17/2013	MVQ
REV	ECO	DESCRIPTION	DATE	APP
WIRING DIAGRAM				
ALTO-SHAM				
BY:	MVQ	DWG:	77391	SHEET
DATE:	11/14/71			1 OF 10

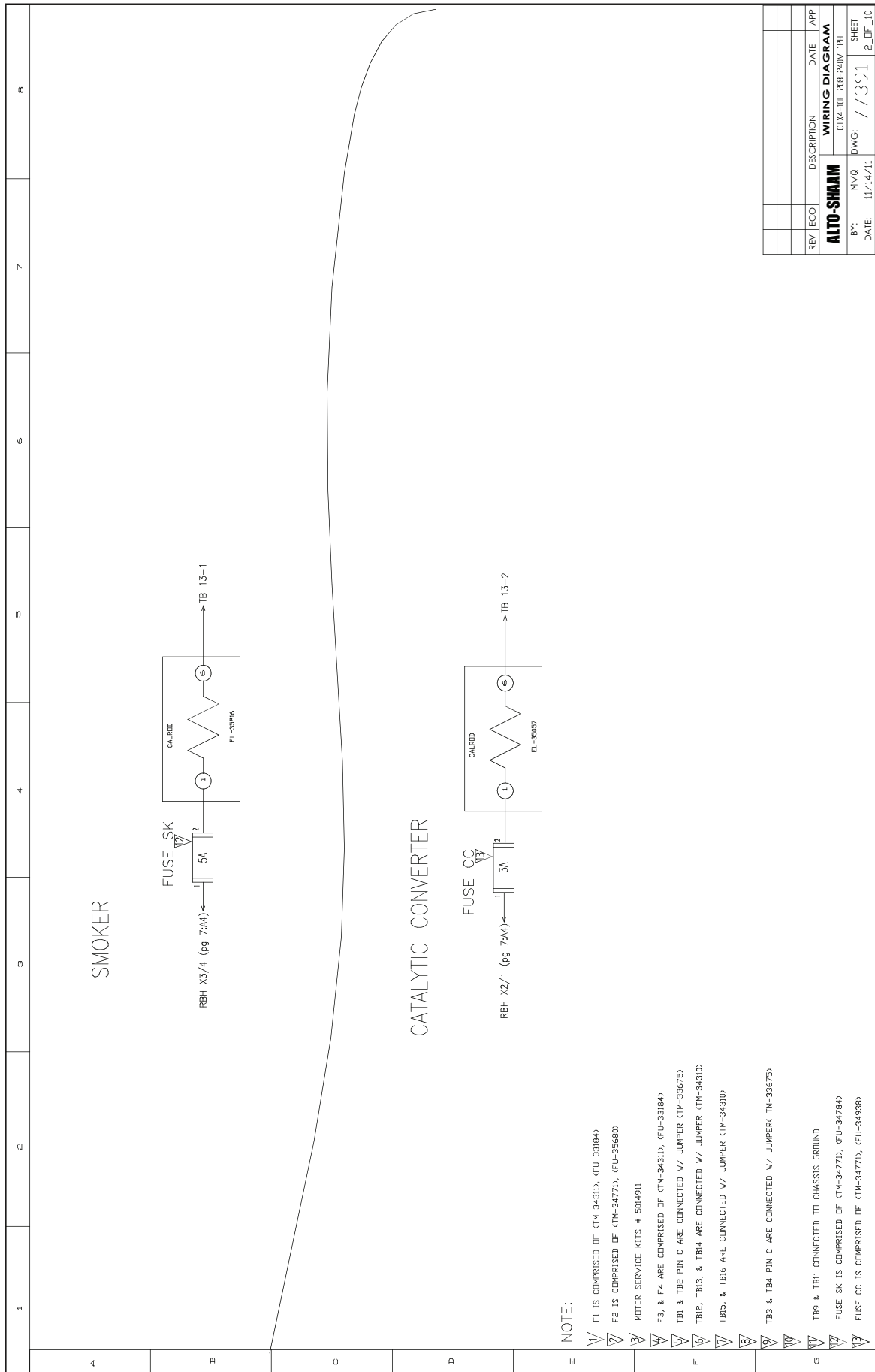

REV	ECO	DESCRIPTION	DATE	APP
WIRING DIAGRAM				
ALTO-SHAAM				
BY:	MVO	DWG:	77391	SHEET
DATE:	11/14/11			2 OF 10

WIRING DIAGRAMS

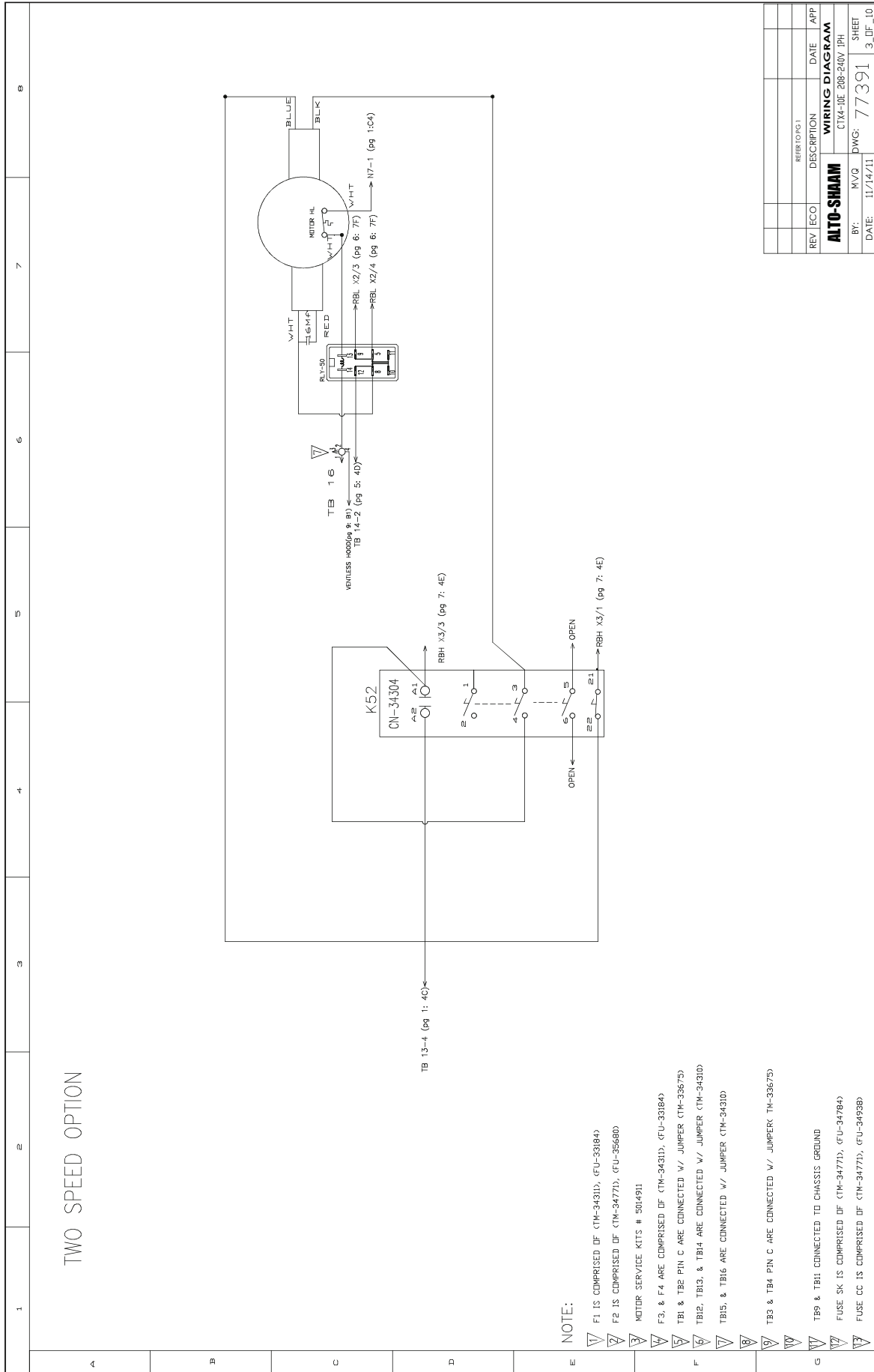

REV	ECO	DESCRIPTION	DATE	APP
WIRING DIAGRAM				
ALTO-SHAAM				
BY:	MVO	DWG:	77391	SHEET
DATE:	11/14/71			3 OF 10

WIRING DIAGRAMS

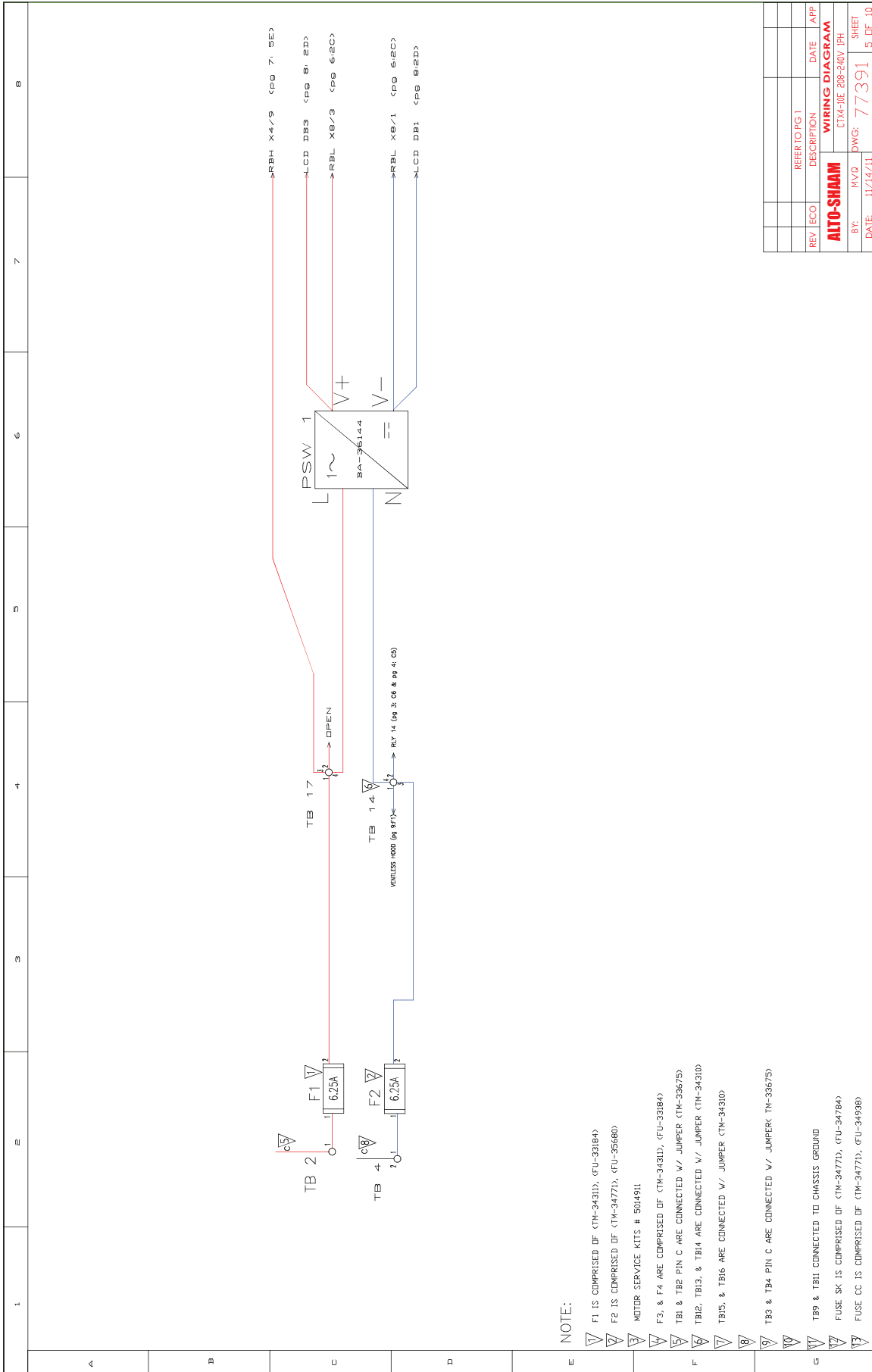

REV	ECO	DESCRIPTION	DATE	APP
		REFER TO PG 1		
WIRING DIAGRAM				
ALTO-SHAAM				
BY:	MVD	DWG:	77391	SHEET
DATE:	11/14/11			5_OF_10

WIRING DIAGRAMS

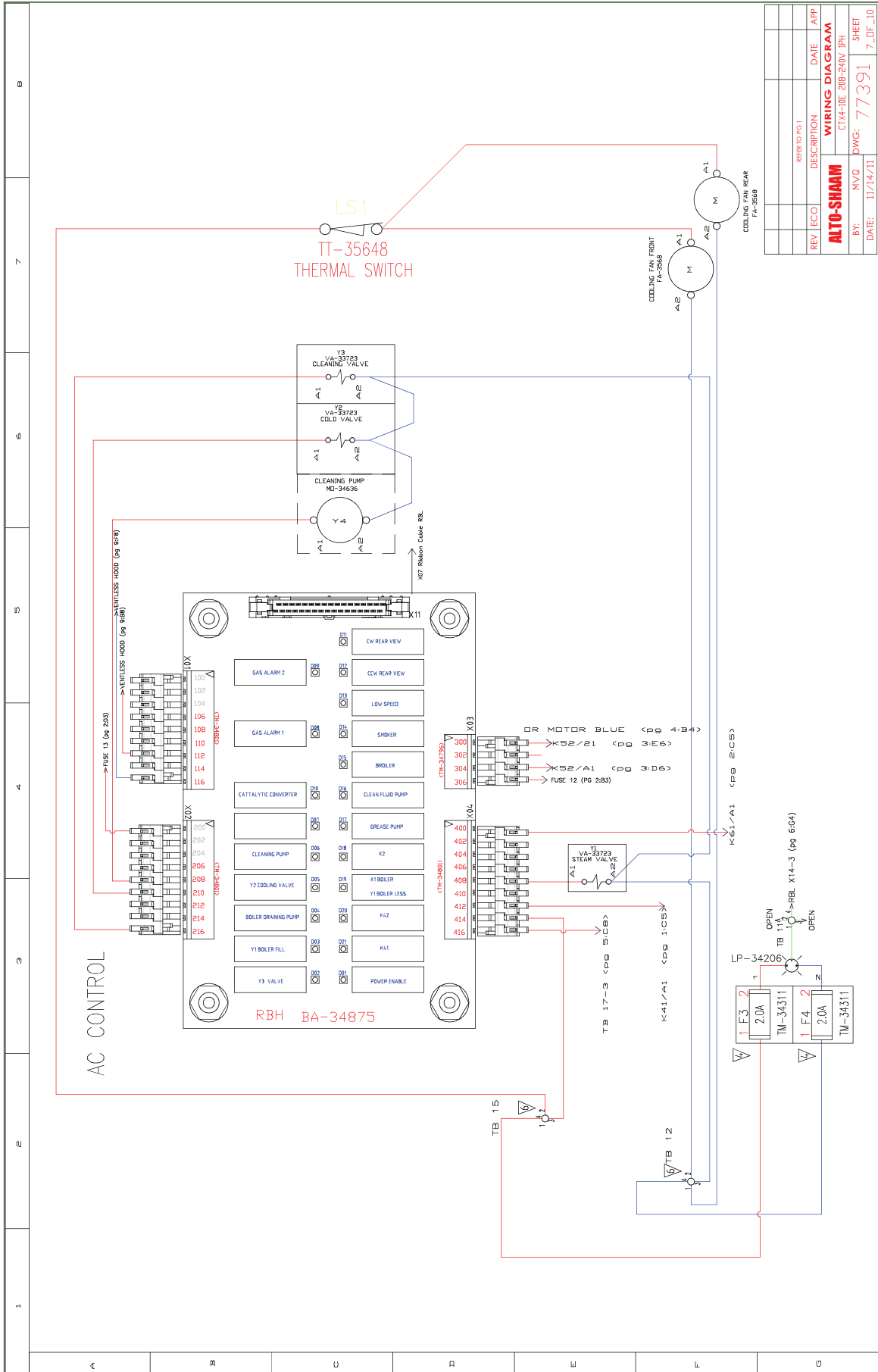

REV	ECO	DESCRIPTION	DATE	APP
		REFER TO PG 1		
WIRING DIAGRAM				
CTX-DE 200-240V JPH				
BY:	MVO	DWG:	77391	SHEET
DATE:	11/14/11			7_DF_10

WIRING DIAGRAMS

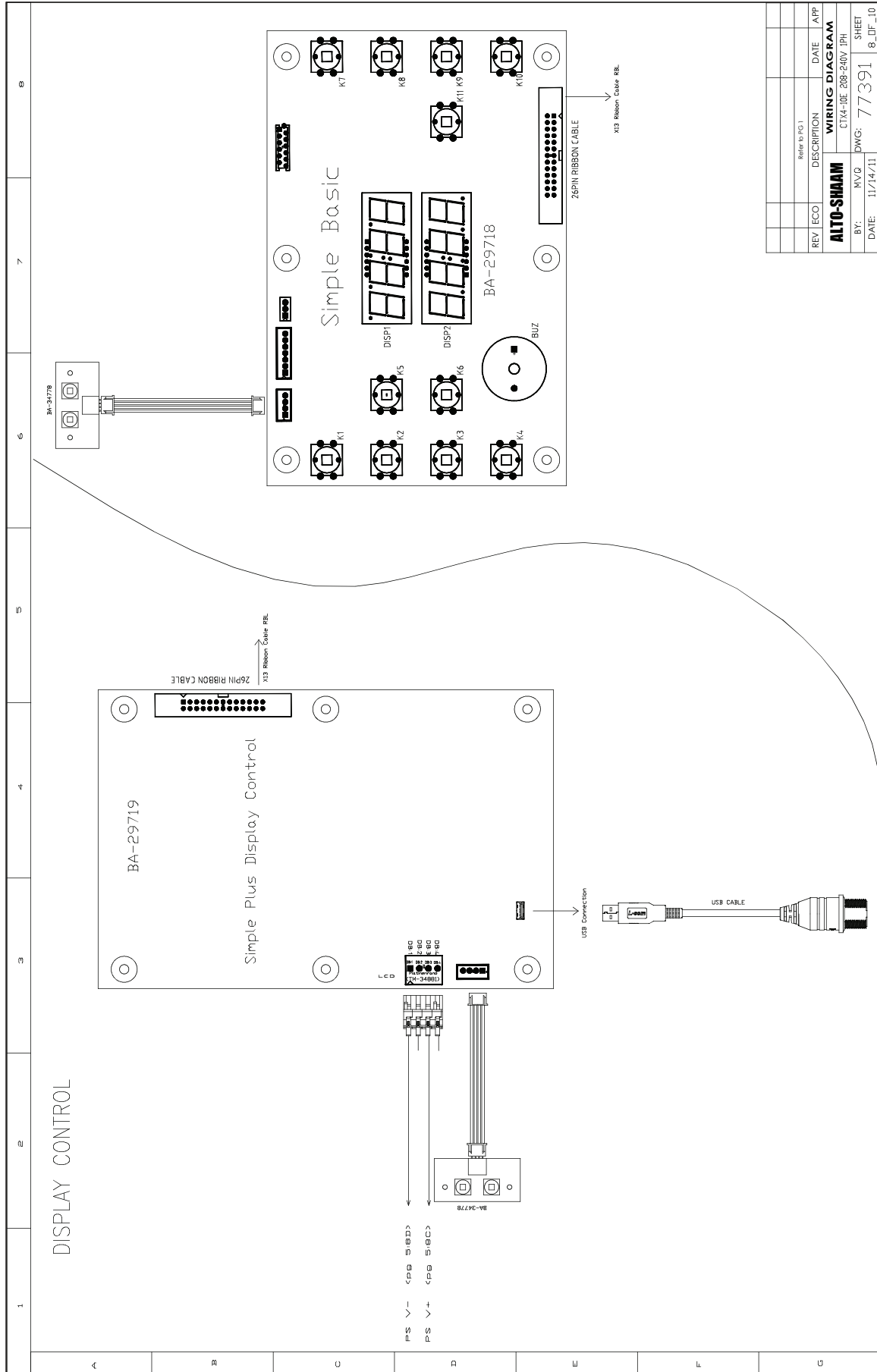

WIRING DIAGRAMS

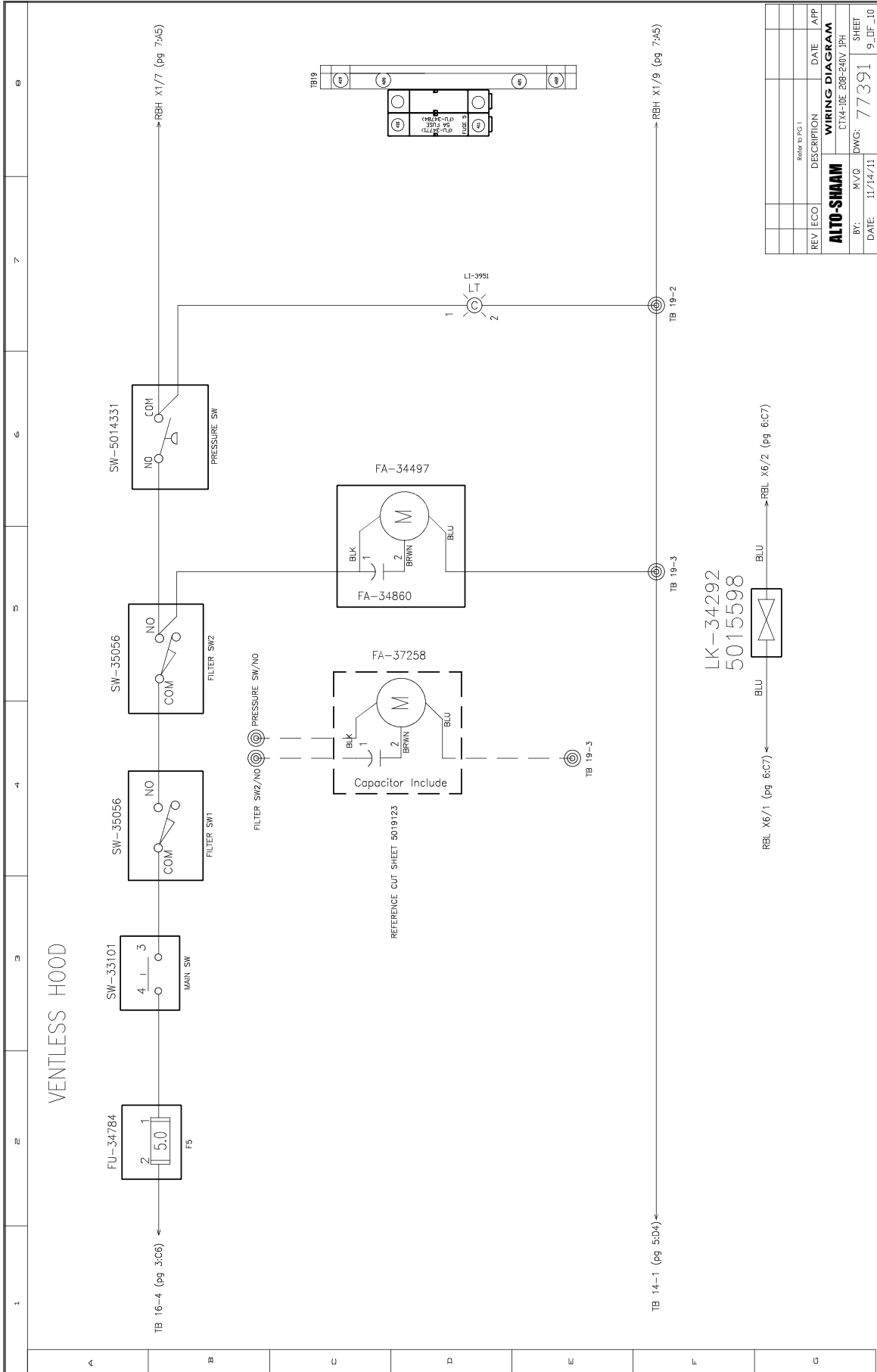

REV	ECCO	DESCRIPTION	DATE	APP
Refer to PC-1				
WIRING DIAGRAM				
CT14-DE-208-240V JPH				
BY:	MVQ	DWG:	77391	SHEET
DATE:	11/14/11			9_DF_10

WIRING DIAGRAMS

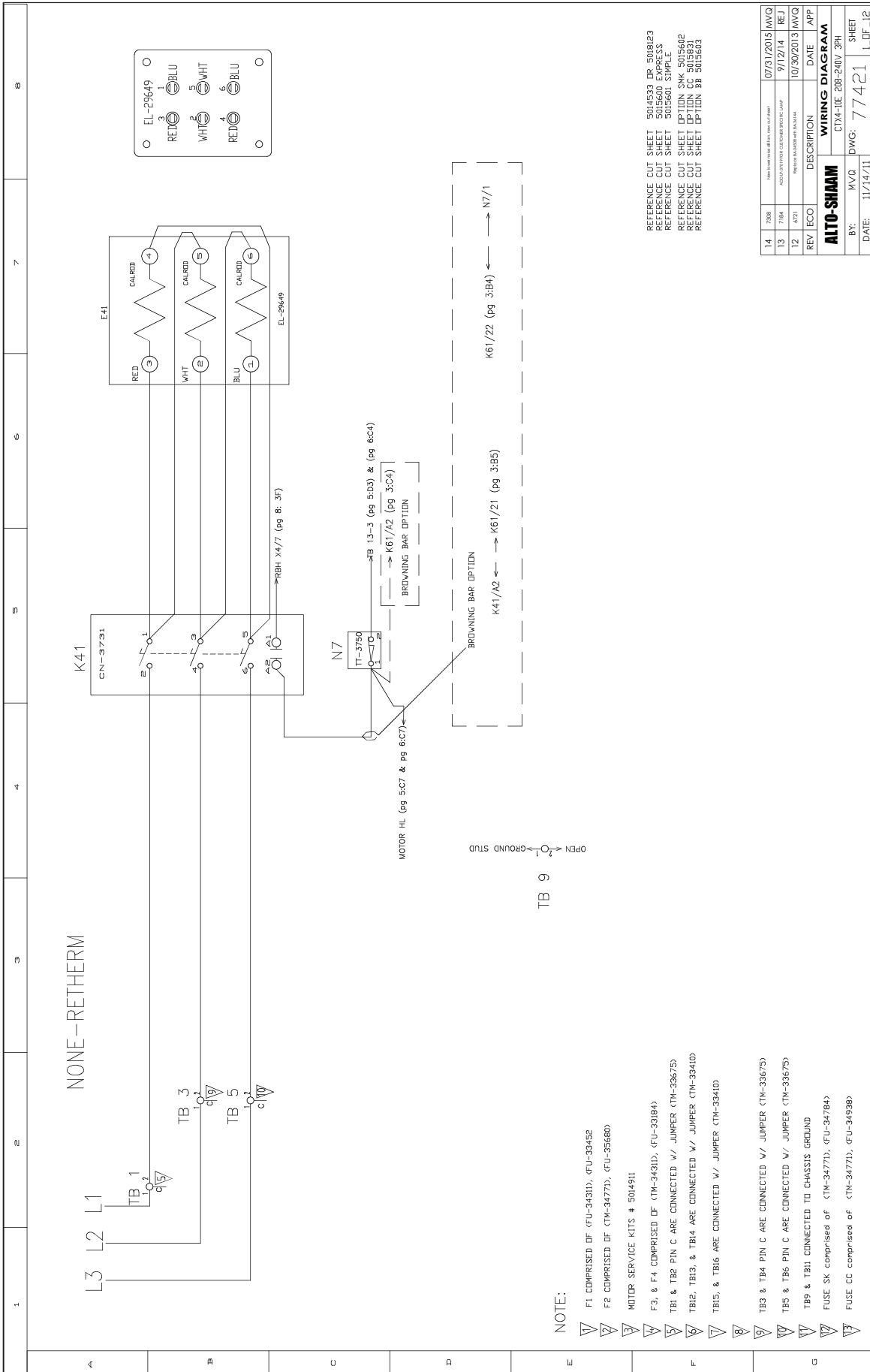

WIRING DIAGRAMS

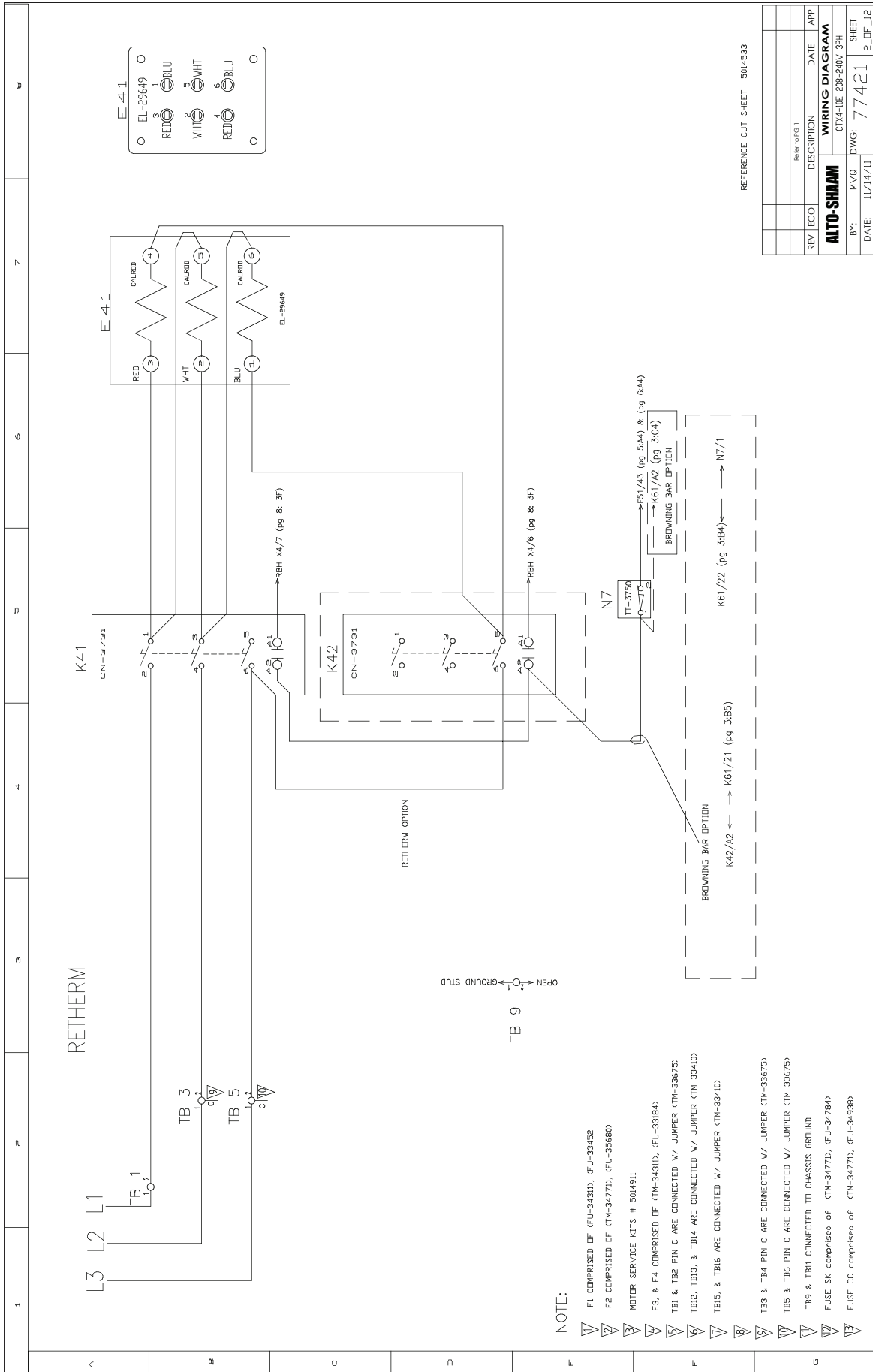

WIRING DIAGRAMS

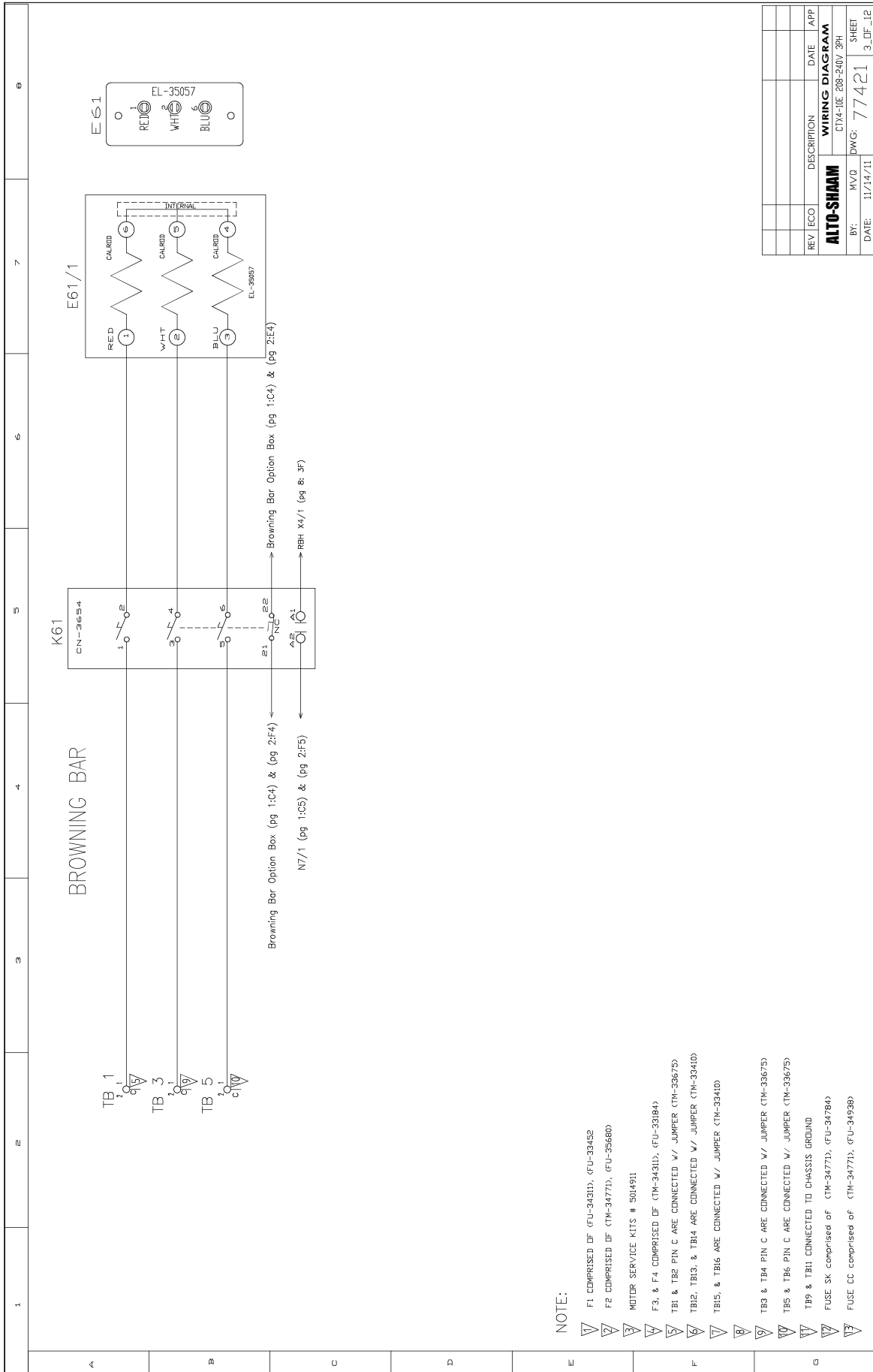

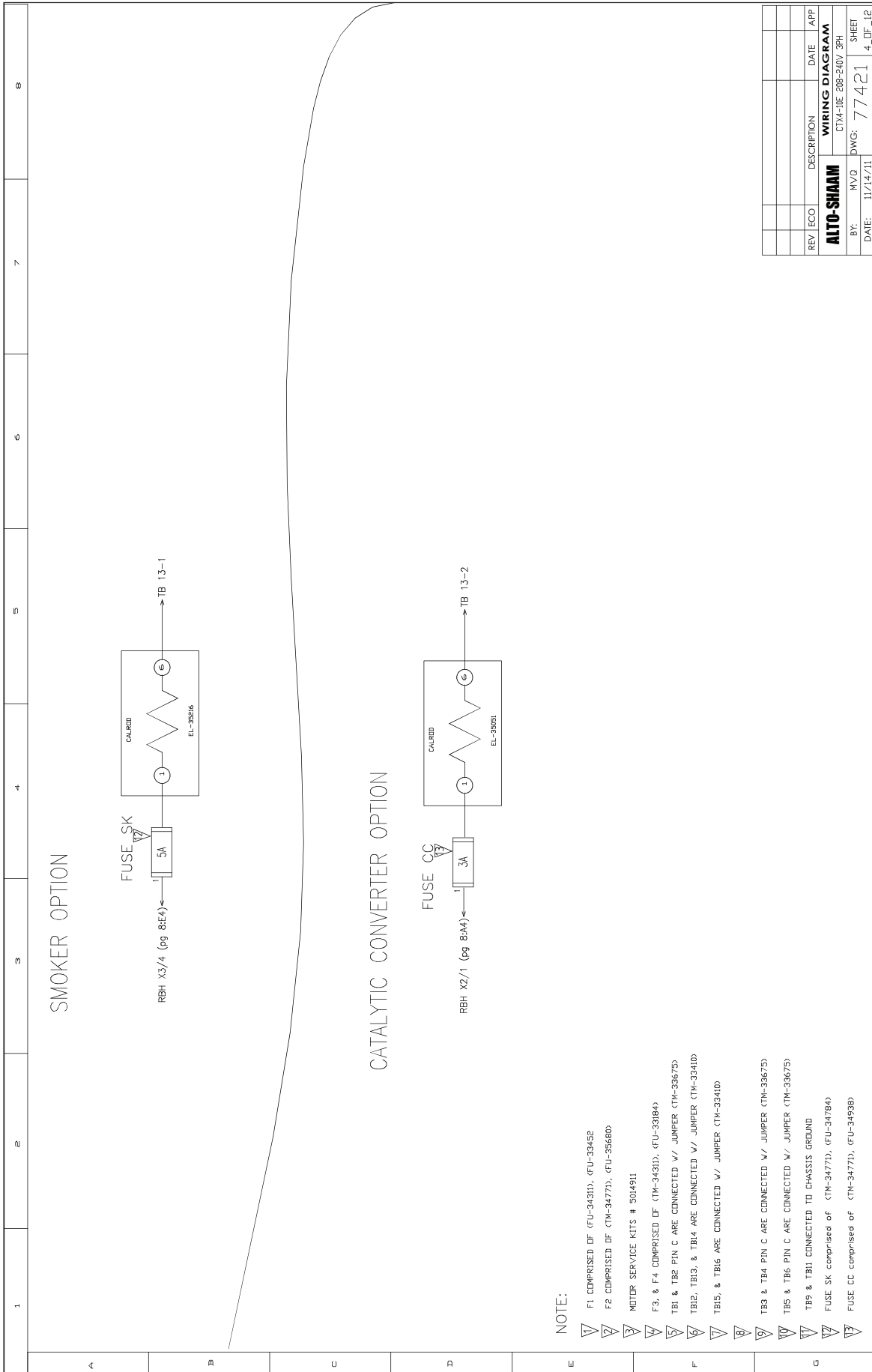

REV	ECO	DESCRIPTION	DATE	APP
		WIRING DIAGRAM		
		ALTO-SHAAM		
BY:	MVO	DWG:	77421	SHEET
DATE:	11/14/11			4_DF_12

WIRING DIAGRAMS

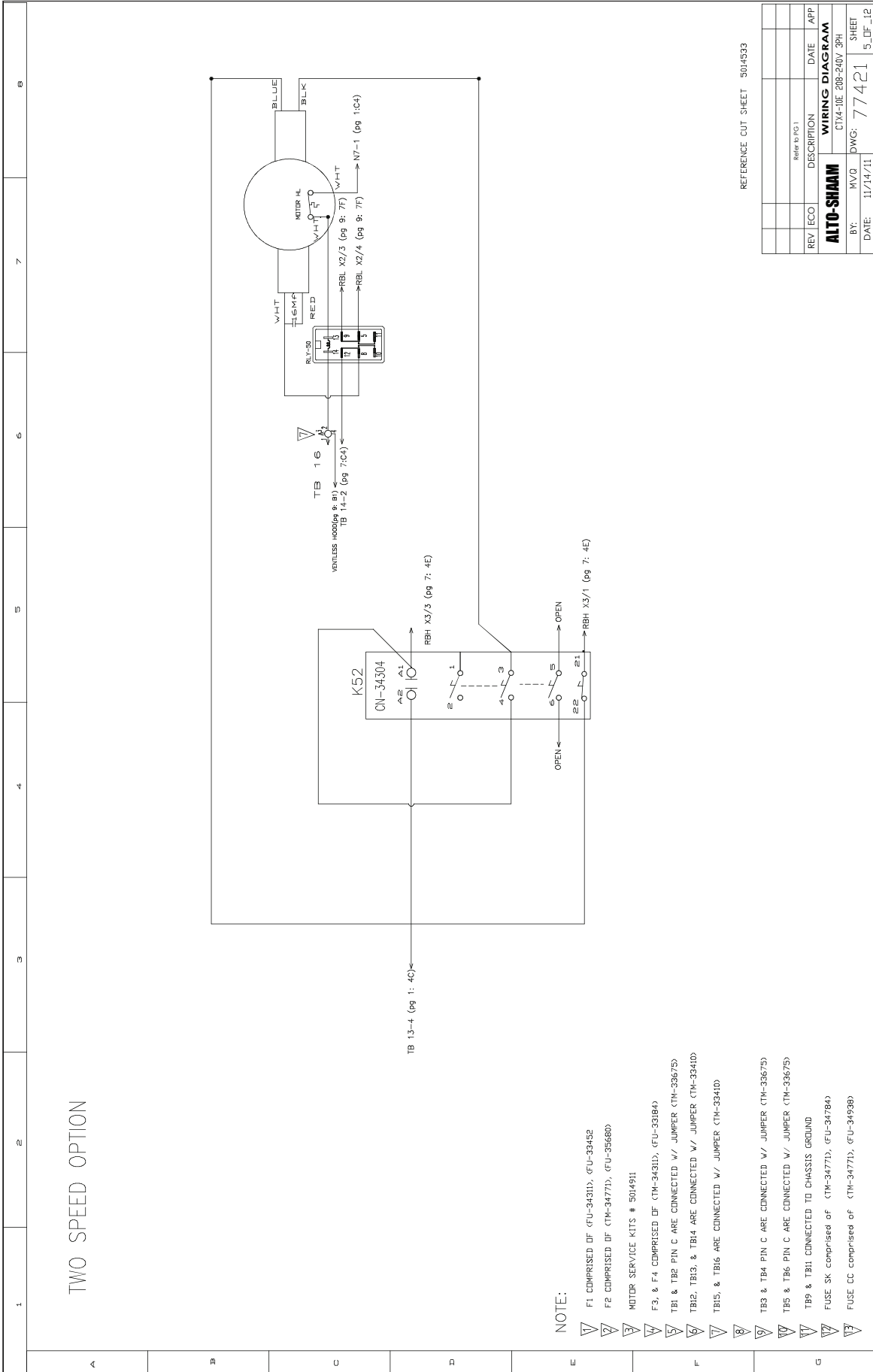

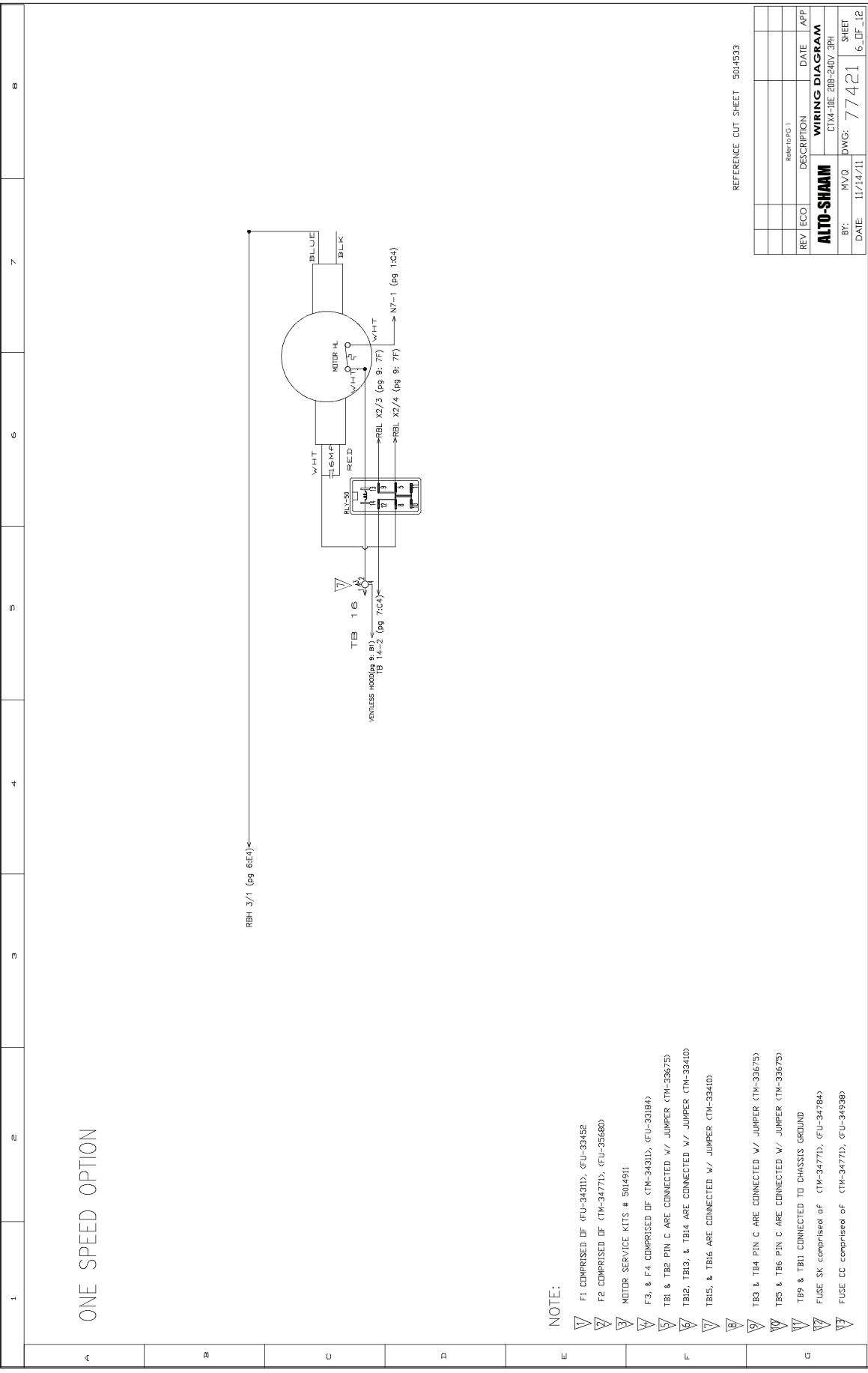

WIRING DIAGRAMS

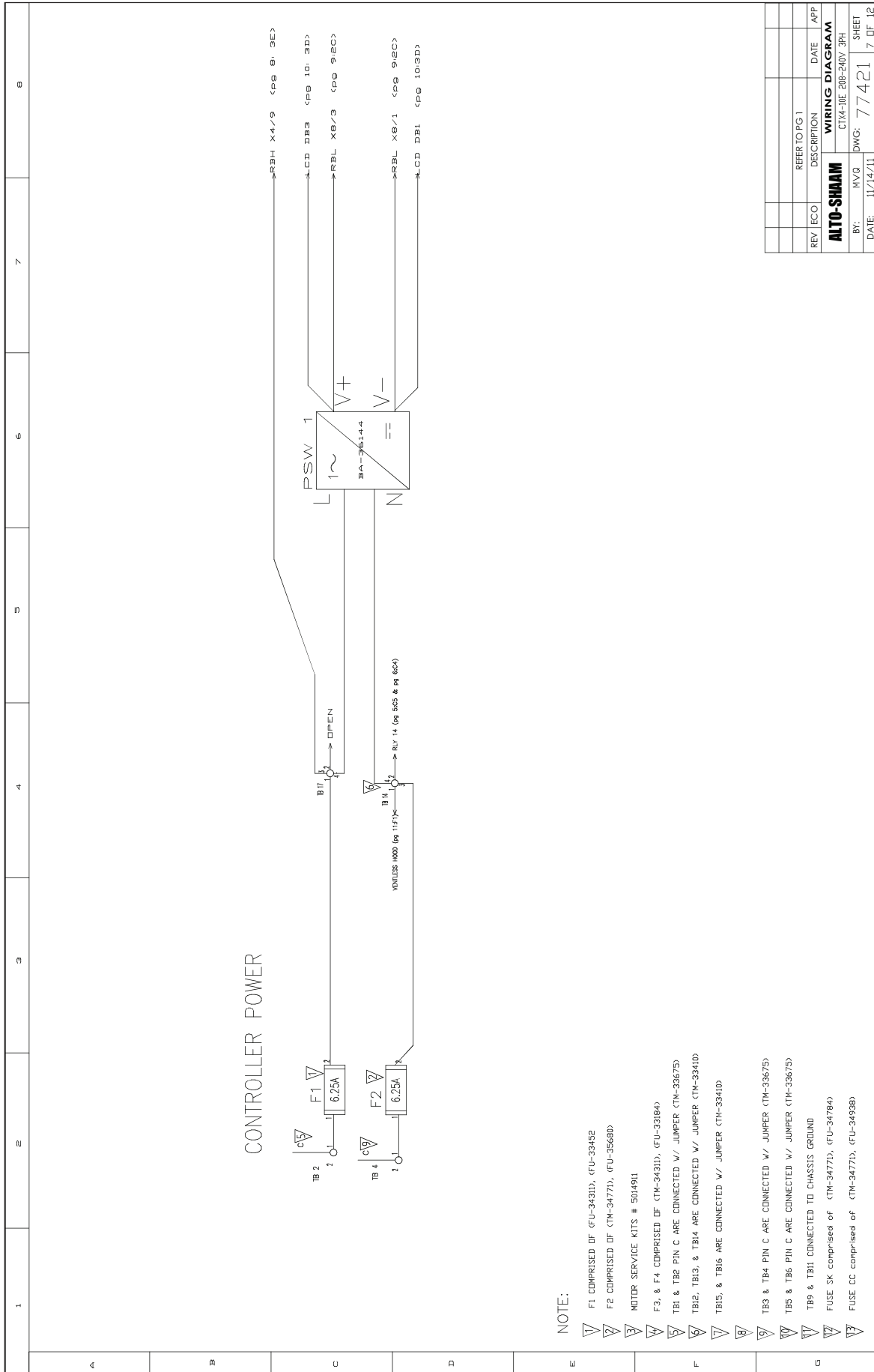

REV	ECO	DESCRIPTION	DATE	APP
		REFER TO PG 1		
WIRING DIAGRAM				
CTX-10E 208-240V 3PH				
BY:	MVG	DWG:	77421	SHEET
DATE:	11/14/11			7 OF 12

WIRING DIAGRAMS

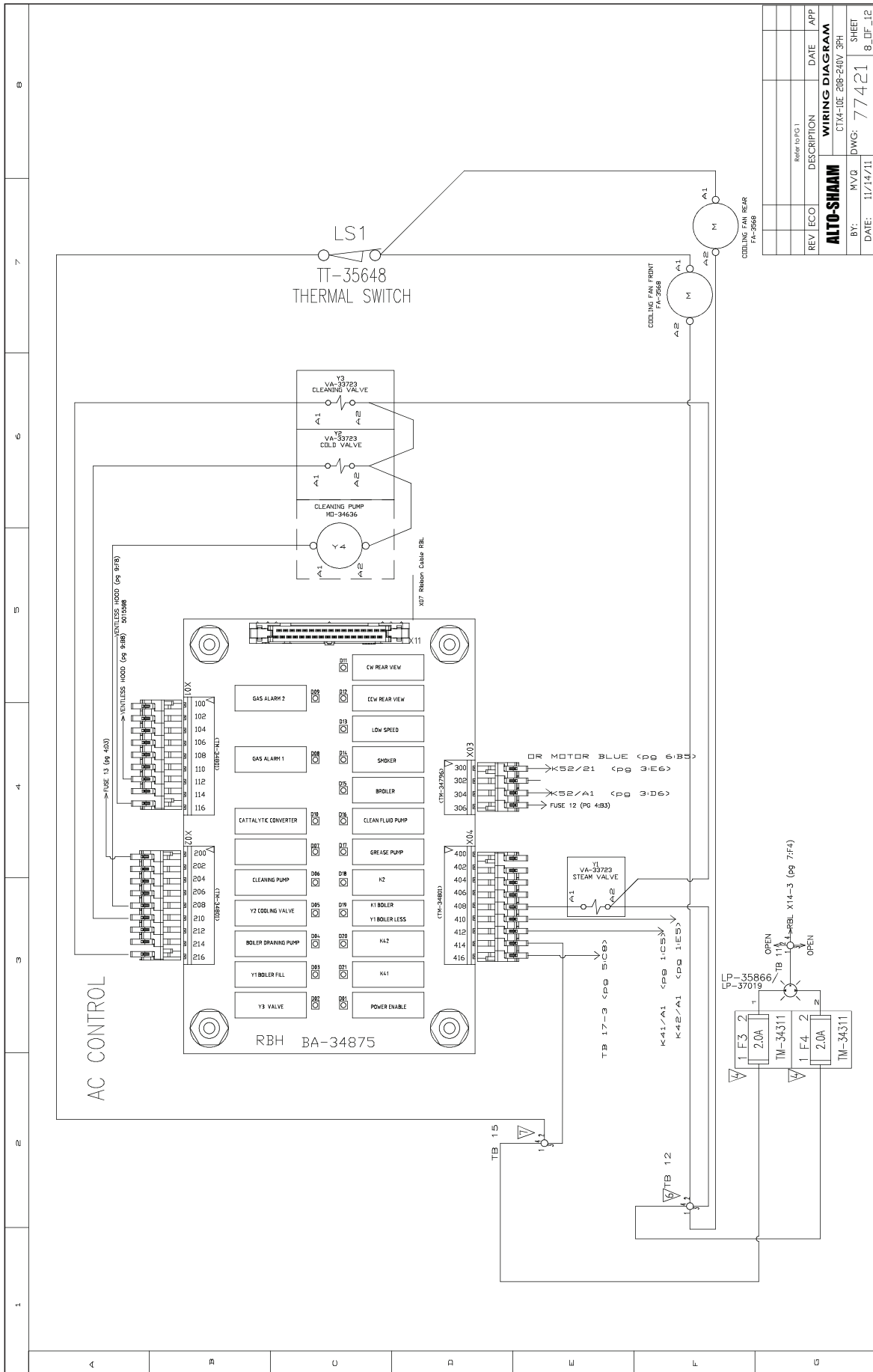

REV	ECO	DESCRIPTION	DATE	APP

Refer to PG 1

WIRING DIAGRAM		DATE	APP
BY:	MVG		
DATE:	11/14/11		

DWG: 77421

SHEET	OF
8	12

WIRING DIAGRAMS

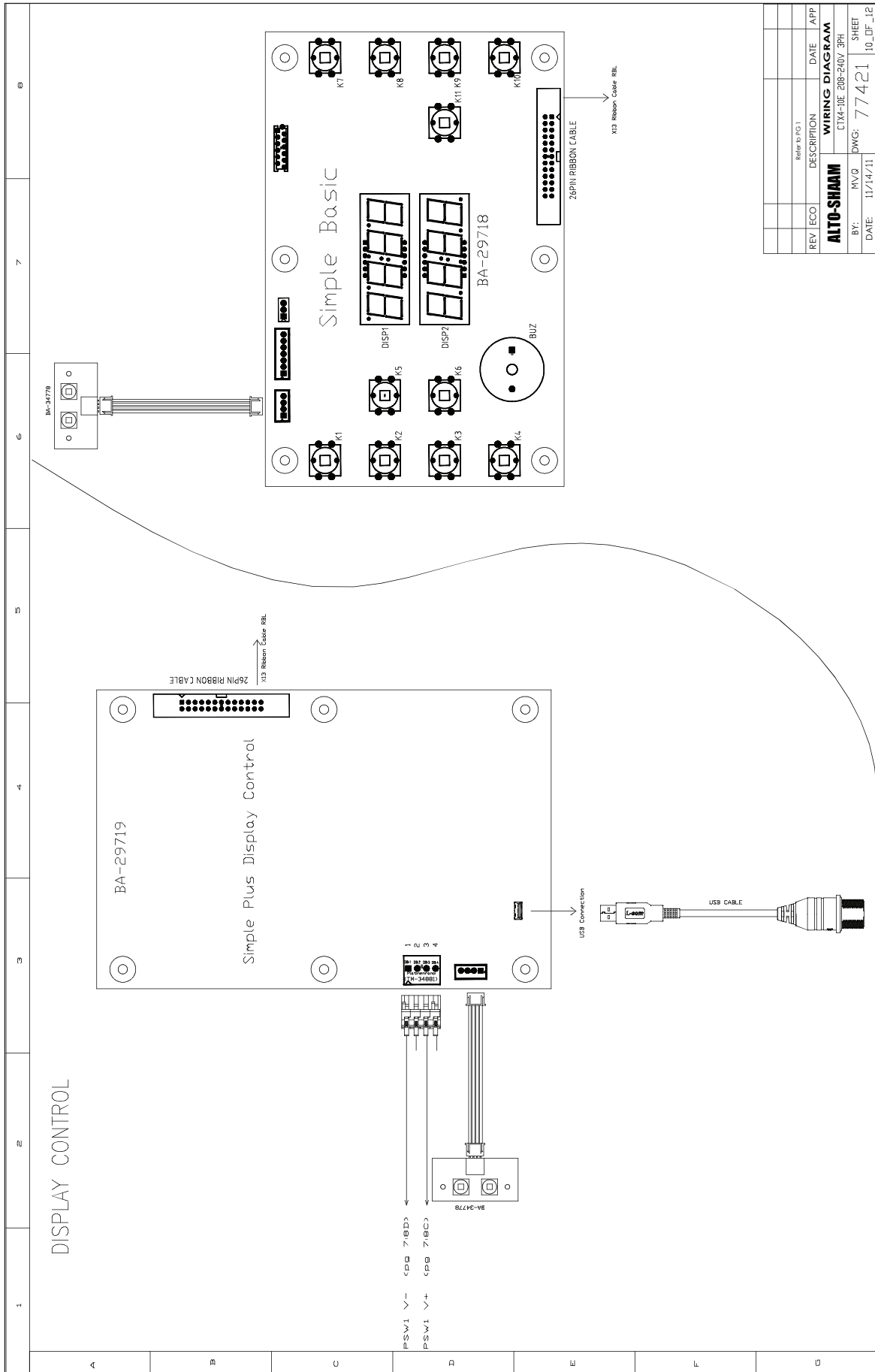

REV	ECO	DESCRIPTION	DATE	APP
WIRING DIAGRAM				
ALTO-SHAAM				
BY:	MVO	DWG:	77421	SHEET
DATE:	11/14/11			10_OF_12

WIRING DIAGRAMS

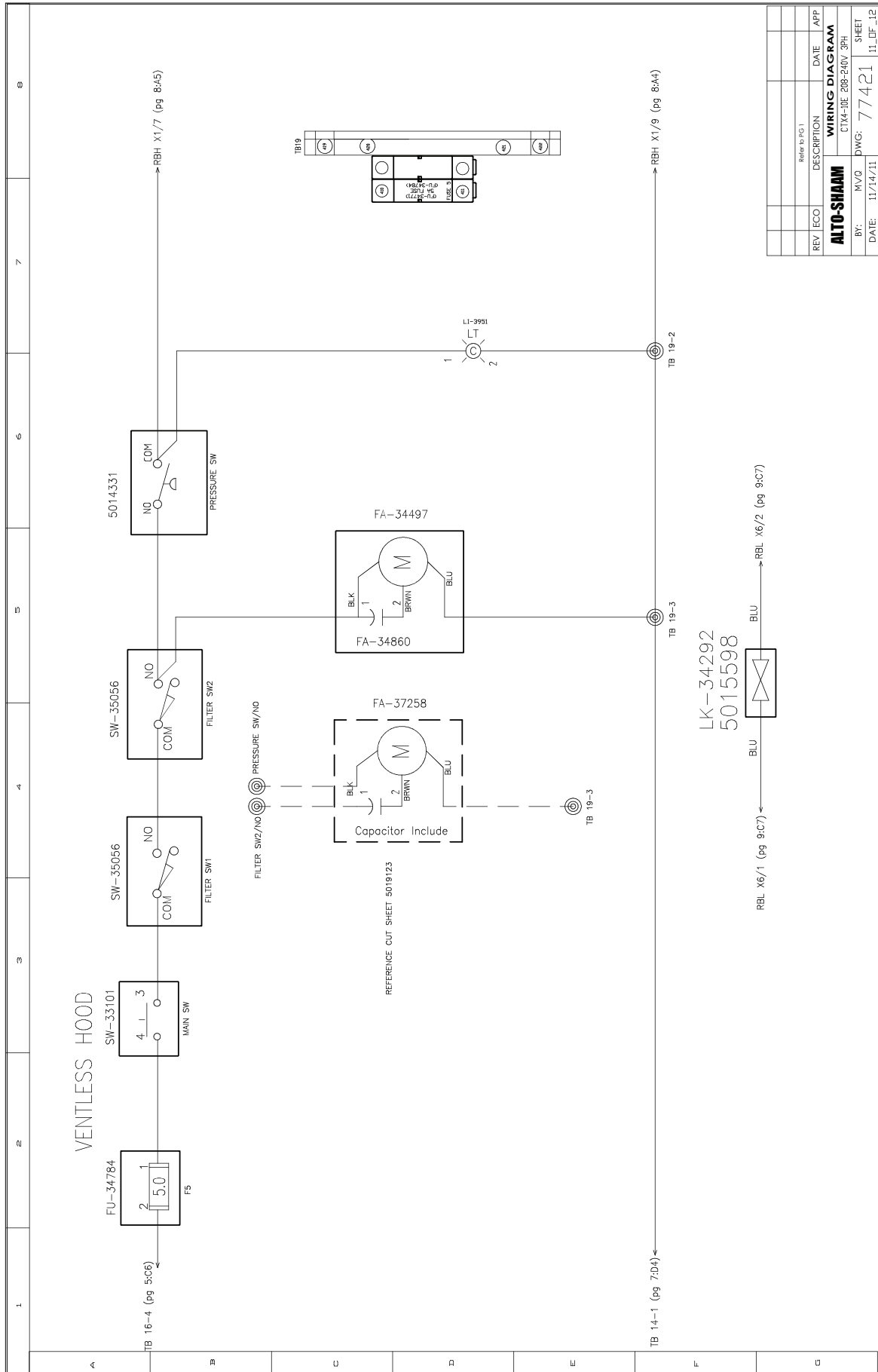

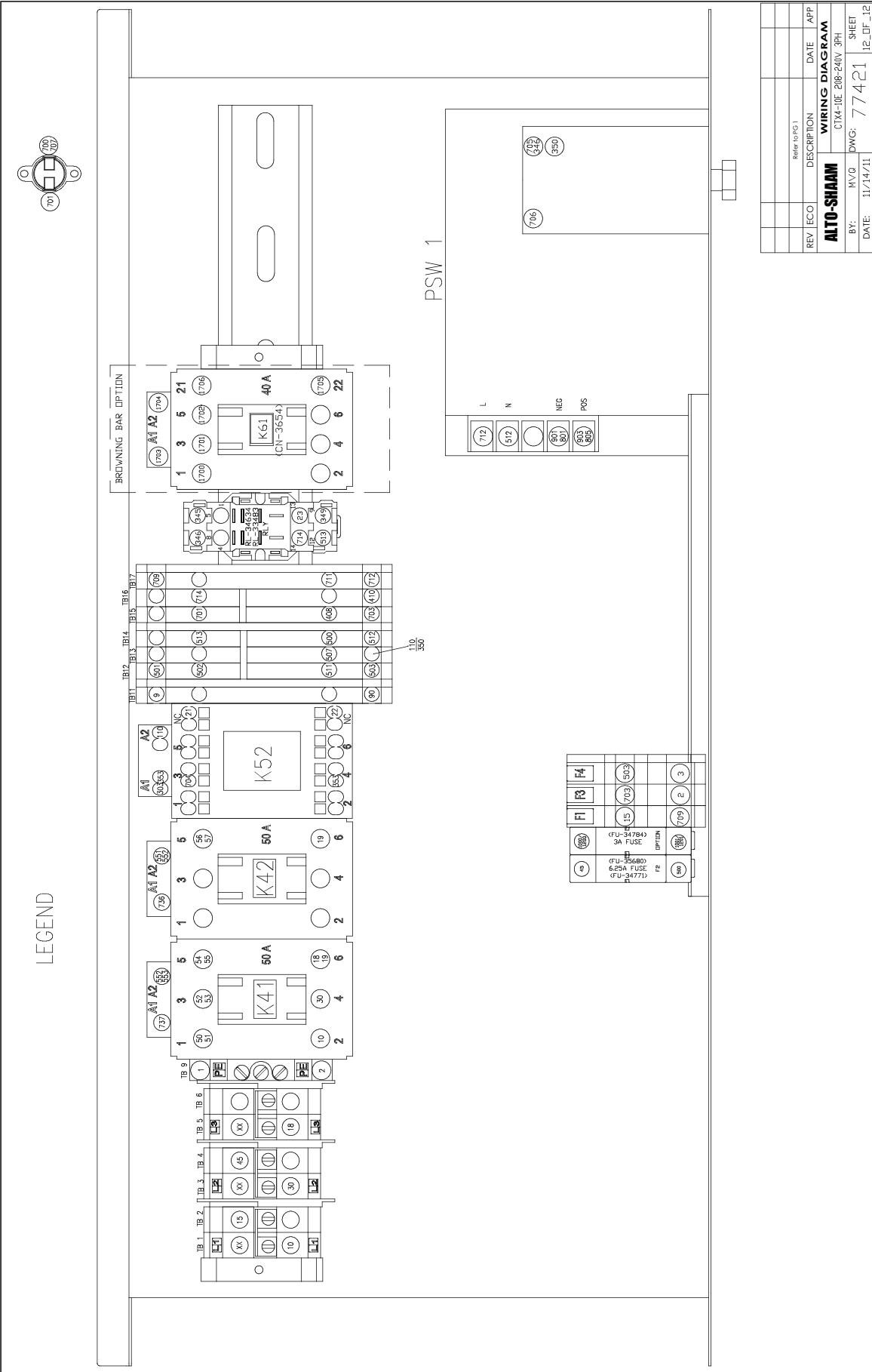

REV	ECO	DESCRIPTION	DATE	APP
Refer to PG.1				
WIRING DIAGRAM				
C14-10E 208-240V 3PH				
BY:	MV/G	DWG:	77421	SHEET
DATE:	11/14/11			12_DF_12

WIRING DIAGRAMS

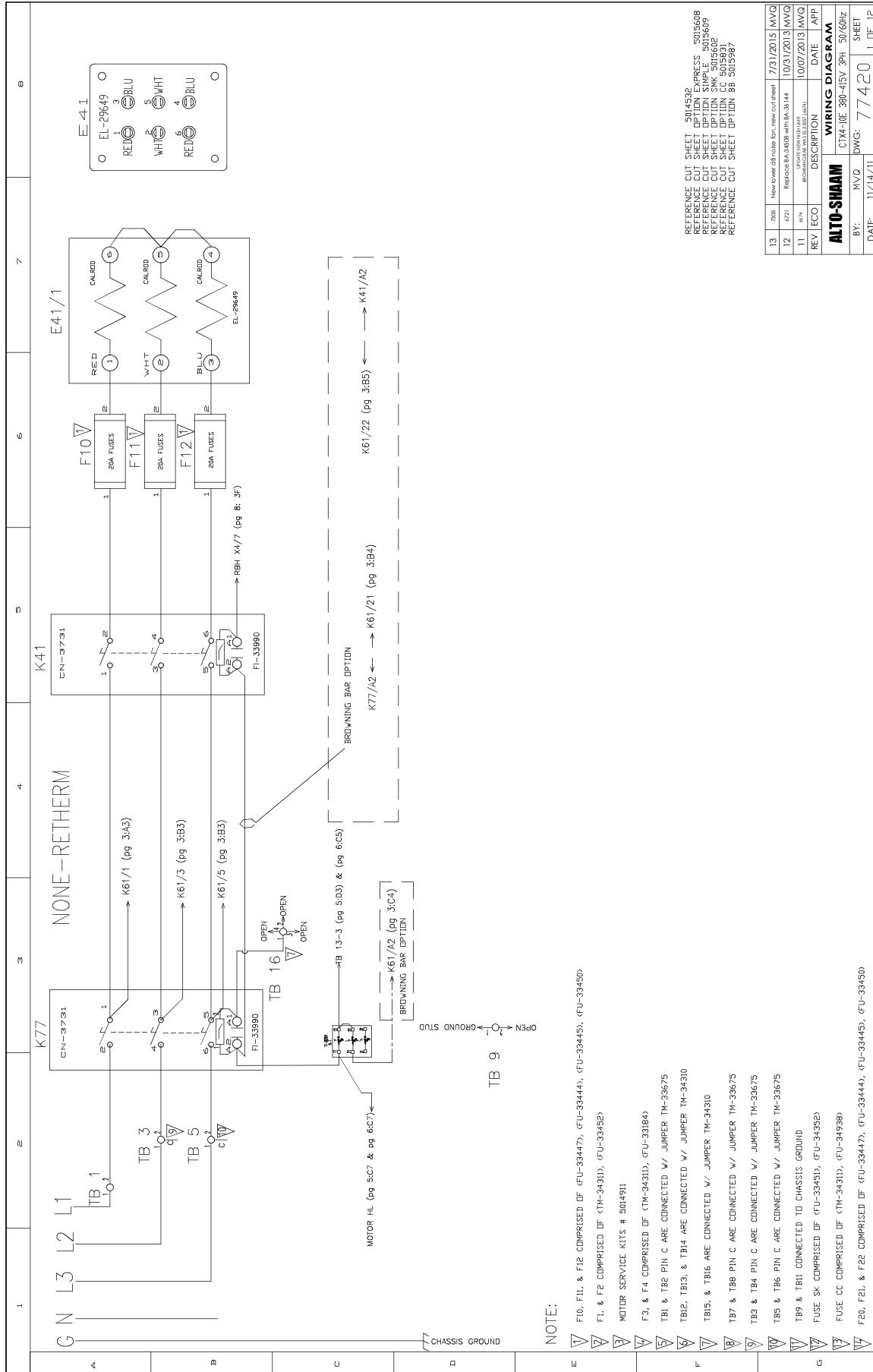

REFERENCE CUT SHEET 5014532
 REFERENCE CUT SHEET OPTION EXPRESS 5015608
 REFERENCE CUT SHEET OPTION SWAP 5015609
 REFERENCE CUT SHEET OPTION SWAP 5015610
 REFERENCE CUT SHEET OPTION CC 5015981
 REFERENCE CUT SHEET OPTION BB 5015987

13	708	New power distribution pin, new cut sheet	7/31/2015	MVQ
12	421	Reference BA-3408 with BA-3414	10/31/2013	MVQ
11	345	Wiring Diagram	10/07/2013	MVQ
REV	ECO	DESCRIPTION	DATE	APP
WIRING DIAGRAM				
ALTO-SHAAM		CT14-10C 380-415V 3PH 50/60Hz		
BY:	MVQ	DWG:	77420	SHEET
DATE:	11/14/11			1_OF_12

WIRING DIAGRAMS

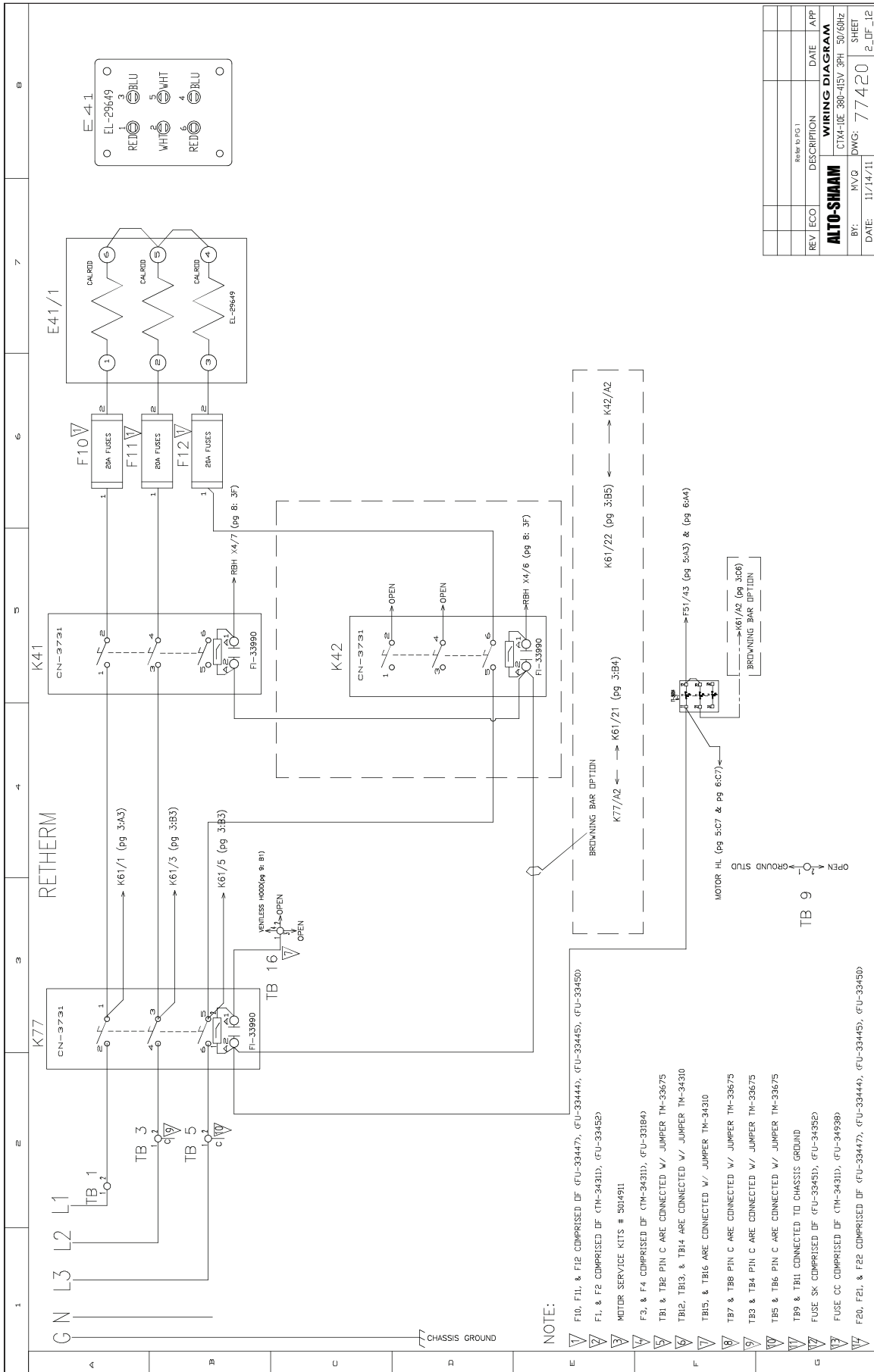

REV	ECO	DESCRIPTION	DATE	APP
WIRING DIAGRAM				
ALTO-SHAAM				
BY:	MVG	DWG:	77420	SHEET
DATE:	11/14/11			2 OF 12

WIRING DIAGRAMS

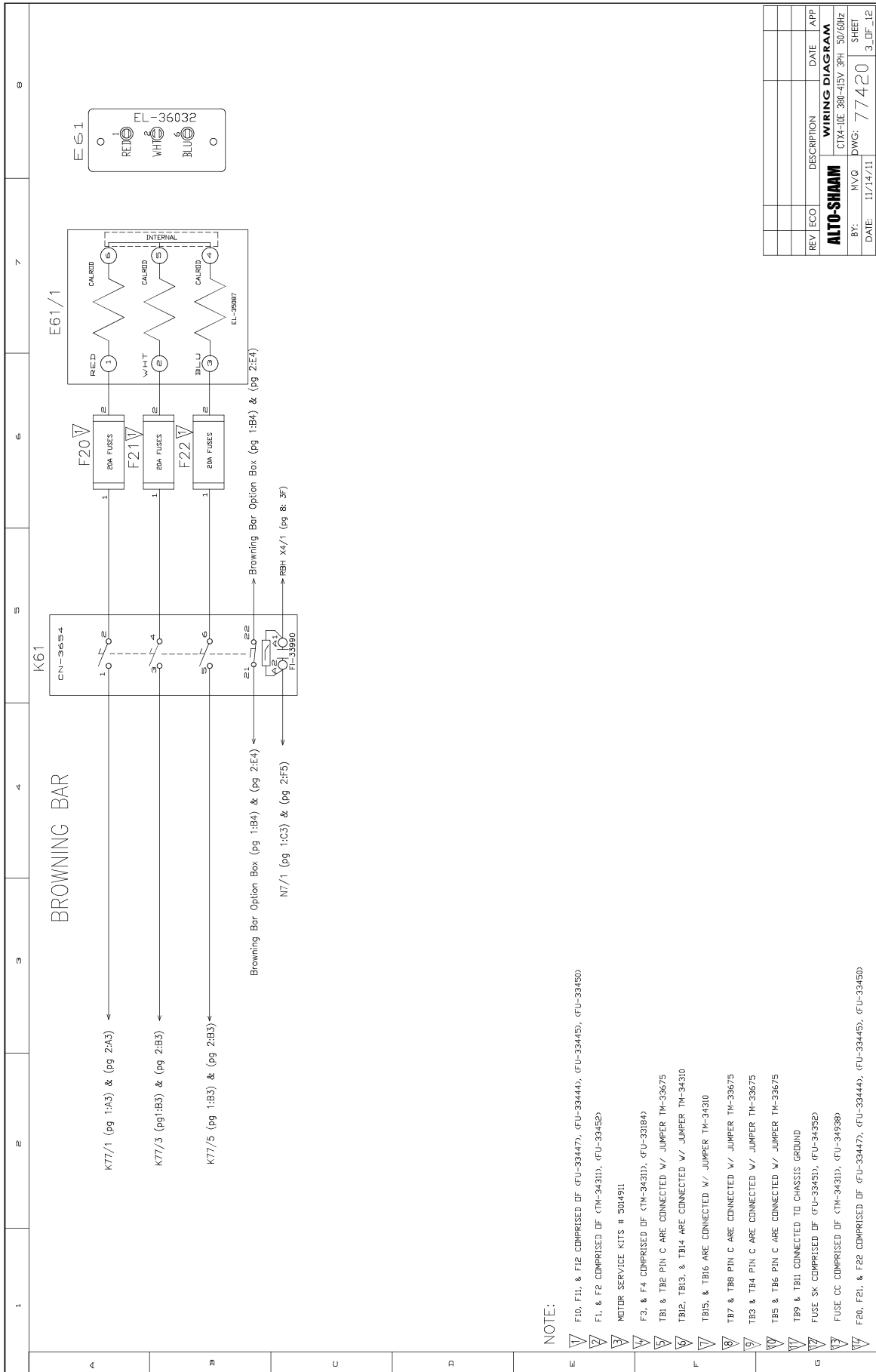

REV	ECO	DESCRIPTION	DATE	APP
WIRING DIAGRAM				
ALTO-SHAAM				
BY:	MVG	DWG:	77420	SHEET
DATE:	11/14/11			3_OF_12

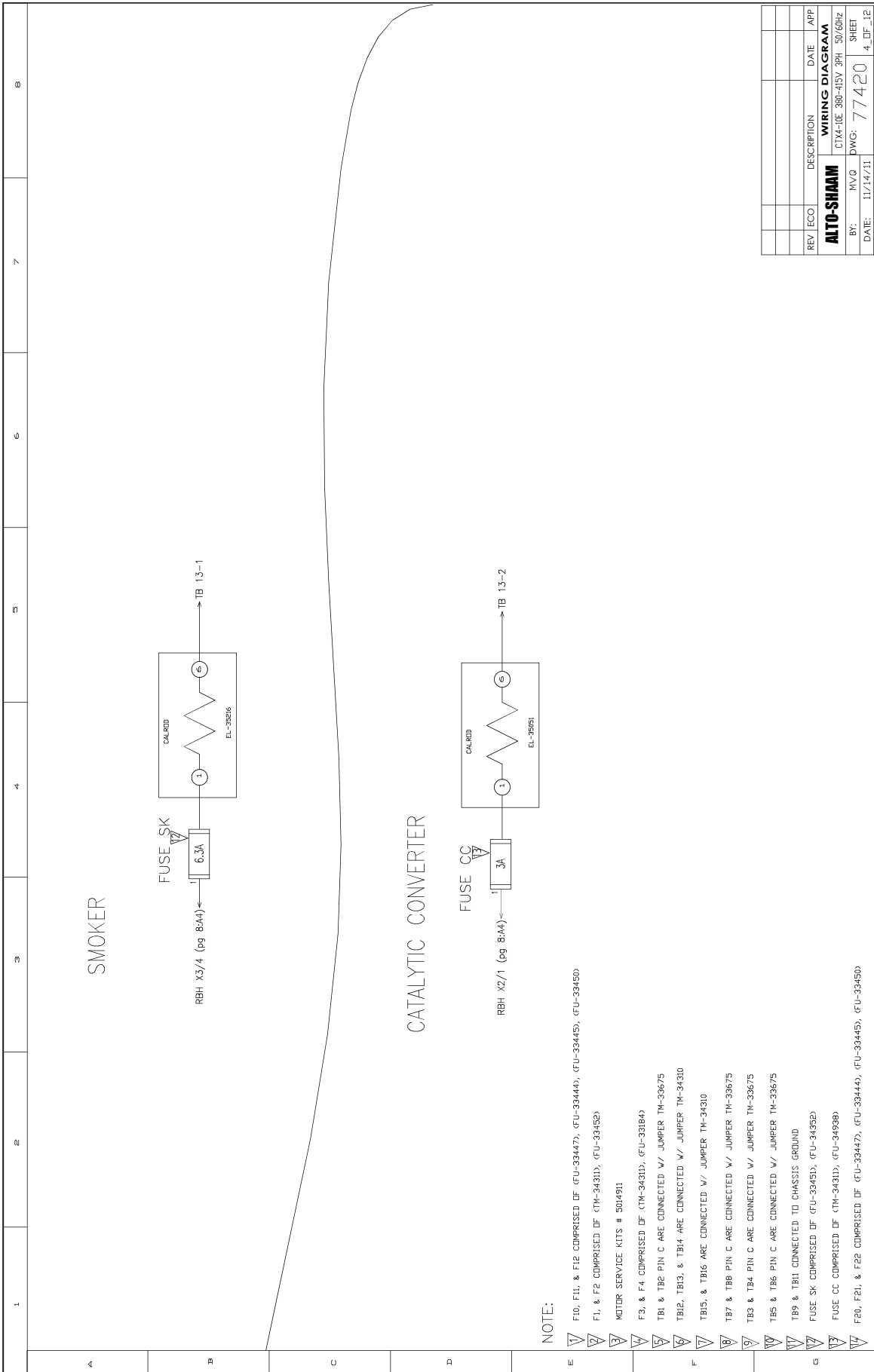

NOTE:

- ▽ F10, F11, & F12 COMPRISED OF (FU-33447), (FU-33444), (FU-33445), (FU-33450)
- ▽ F1, & F2 COMPRISED OF (TM-34310), (FU-33452)
- ▽ MOTOR SERVICE KITS # 501491
- ▽ F3, & F4 COMPRISED OF (TM-34310), (FU-33184)
- ▽ TB1 & TB6 PIN C ARE CONNECTED W/ JUMPER TM-33675
- ▽ TB2, TB3, & TB4 ARE CONNECTED W/ JUMPER TM-34310
- ▽ TB5, & TB6 ARE CONNECTED W/ JUMPER TM-34310
- ▽ TB7 & TB8 PIN C ARE CONNECTED W/ JUMPER TM-33675
- ▽ TB3 & TB4 PIN C ARE CONNECTED W/ JUMPER TM-33675
- ▽ TB5 & TB6 PIN C ARE CONNECTED W/ JUMPER TM-33675
- ▽ TB9 & TB11 CONNECTED TO CHASSIS GROUND
- ▽ FUSE SK COMPRISED OF (FU-33451), (FU-34352)
- ▽ FUSE CC COMPRISED OF (TM-34310), (FU-34938)
- ▽ F20, F21, & F22 COMPRISED OF (FU-33447), (FU-33444), (FU-33445), (FU-33450)

REV	ECO	DESCRIPTION	DATE	APP
WIRING DIAGRAM				
ALTO-SHAAM				
BY:	MVG	DWG:	77420	SHEET
DATE:	11/14/11			4_DF_12

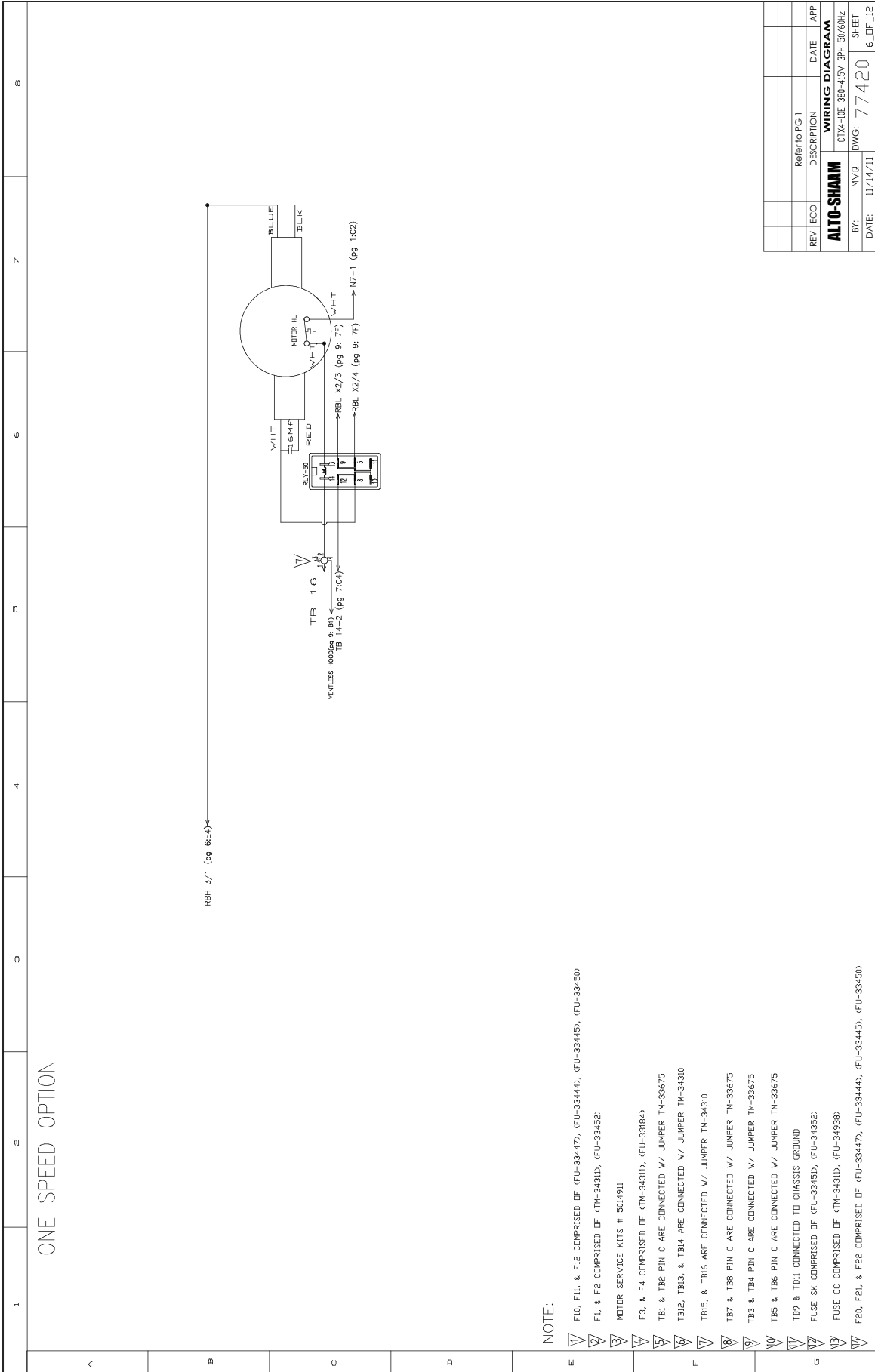

WIRING DIAGRAMS

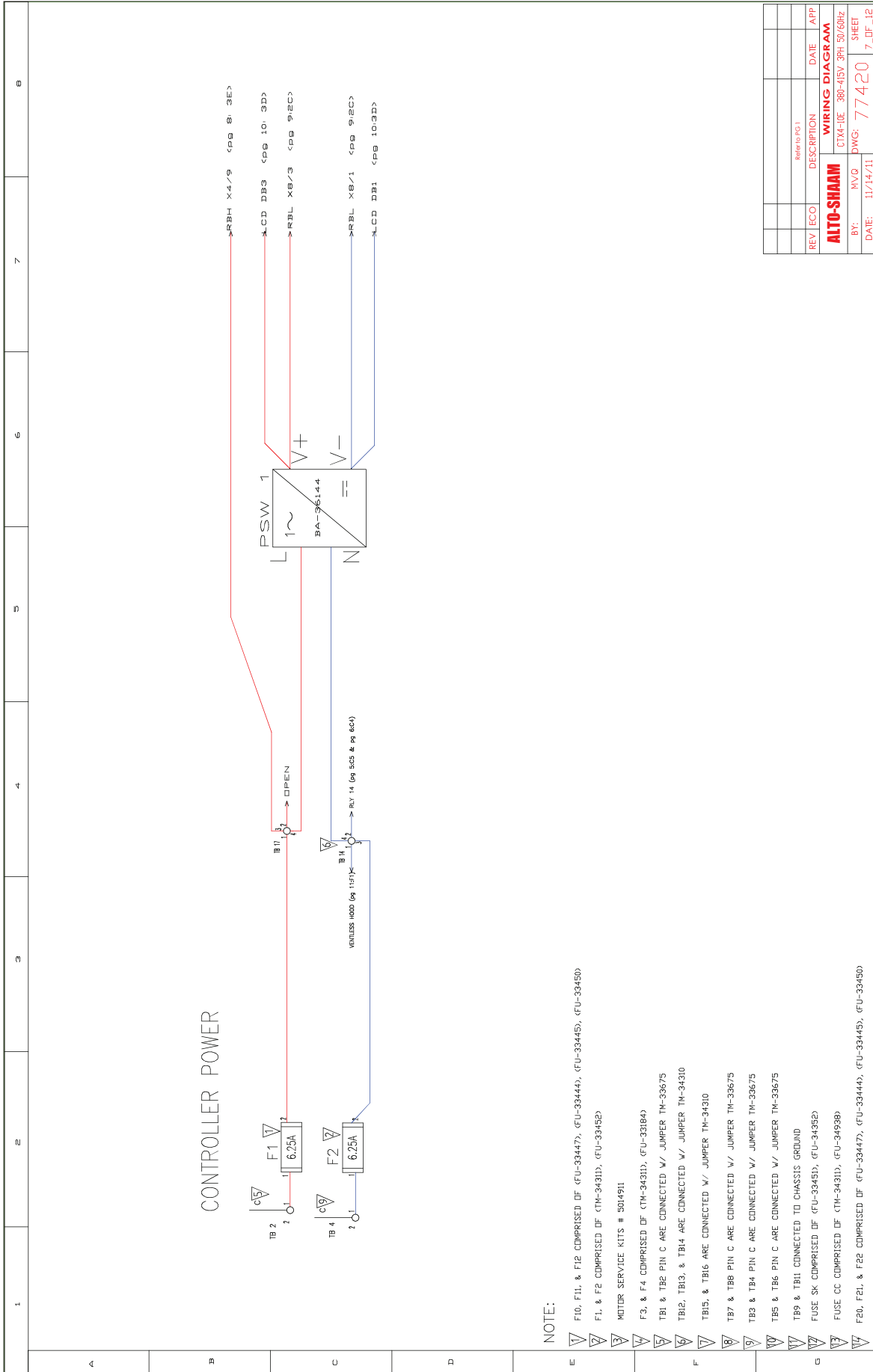

REV	ECO	DESCRIPTION	DATE	APP
		Refer to PG 1		
WIRING DIAGRAM				
CYX-10E 380-415V 3PH 50/60HZ				
BY:	MVO	DWG:	77420	SHEET 7 OF 12
DATE:	11/14/11			

WIRING DIAGRAMS

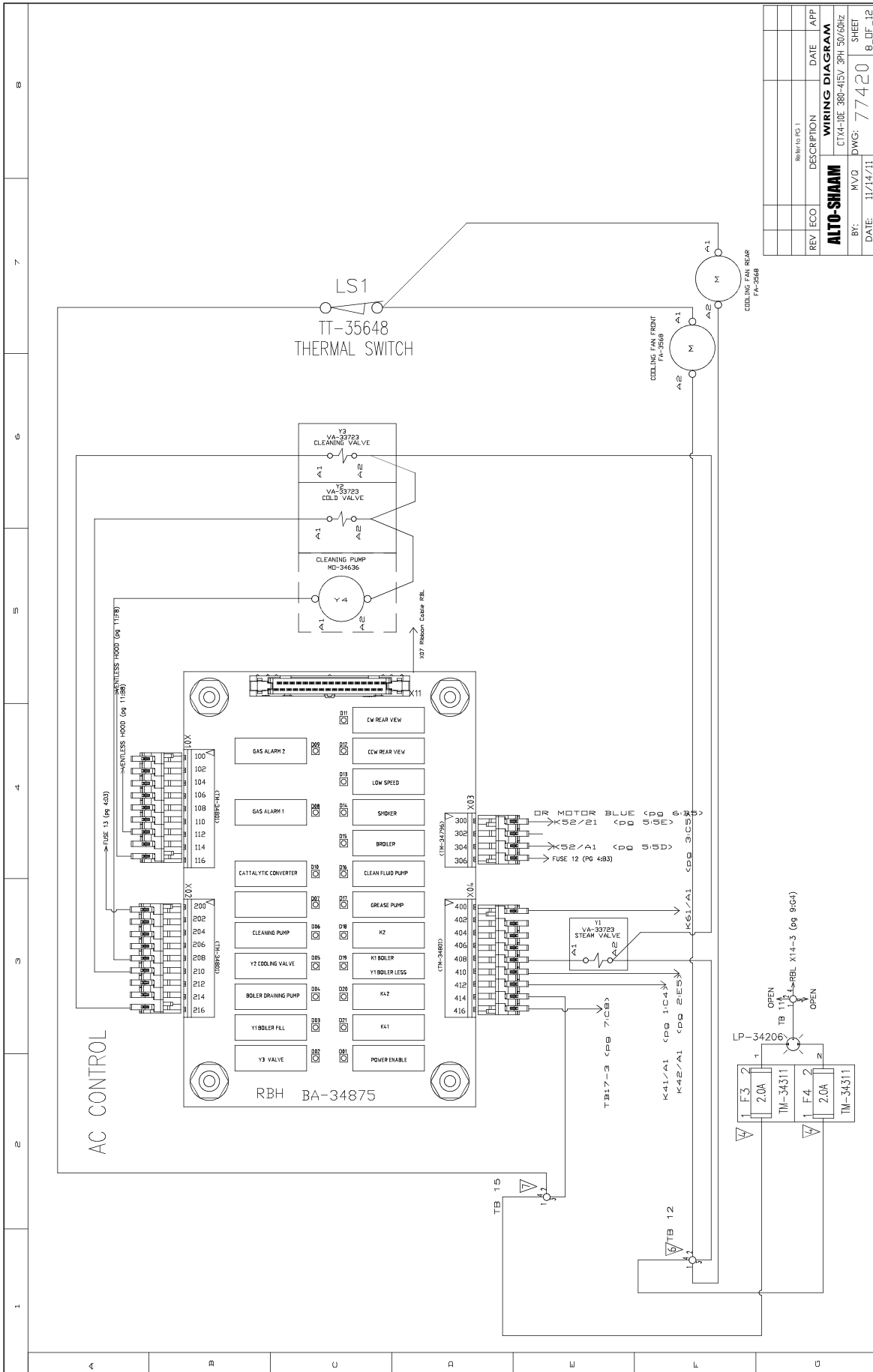

REV	ECO	DESCRIPTION	DATE	APP
		Refer to PG 1		
WIRING DIAGRAM				
AUTO-SHAAM				
BY:	MVQ	DWG:	77420	SHEET
DATE:	11/14/11			8_DF_12

WIRING DIAGRAMS

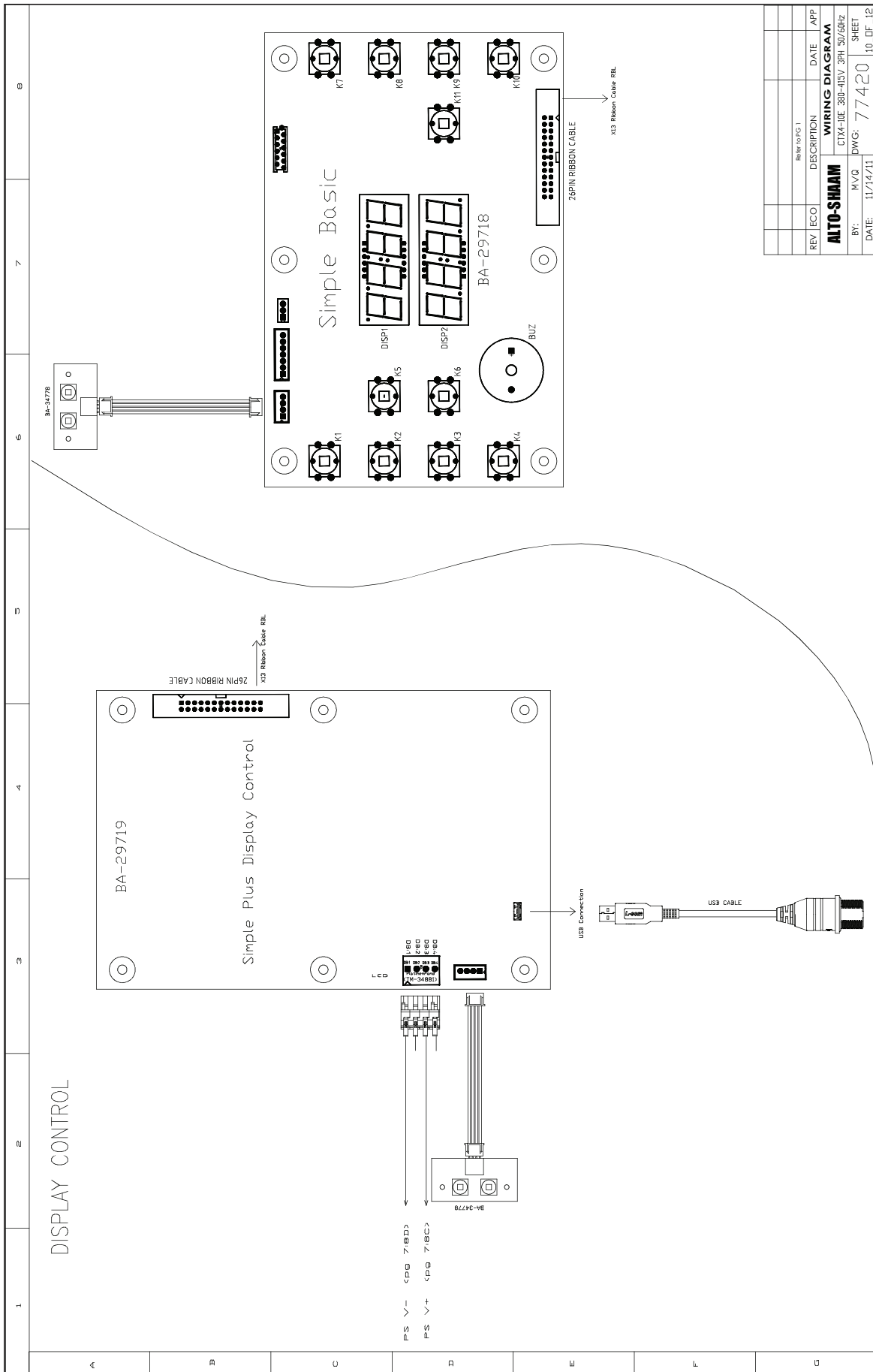

REV	ECCO	DESCRIPTION	DATE	APP
		Refer to PG 1		
WIRING DIAGRAM				
ALTO-SHAMAM				
BY:	M/V/Q	DWG:	77420	SHEET
DATE:	11/14/11			10_OF_12

WIRING DIAGRAMS

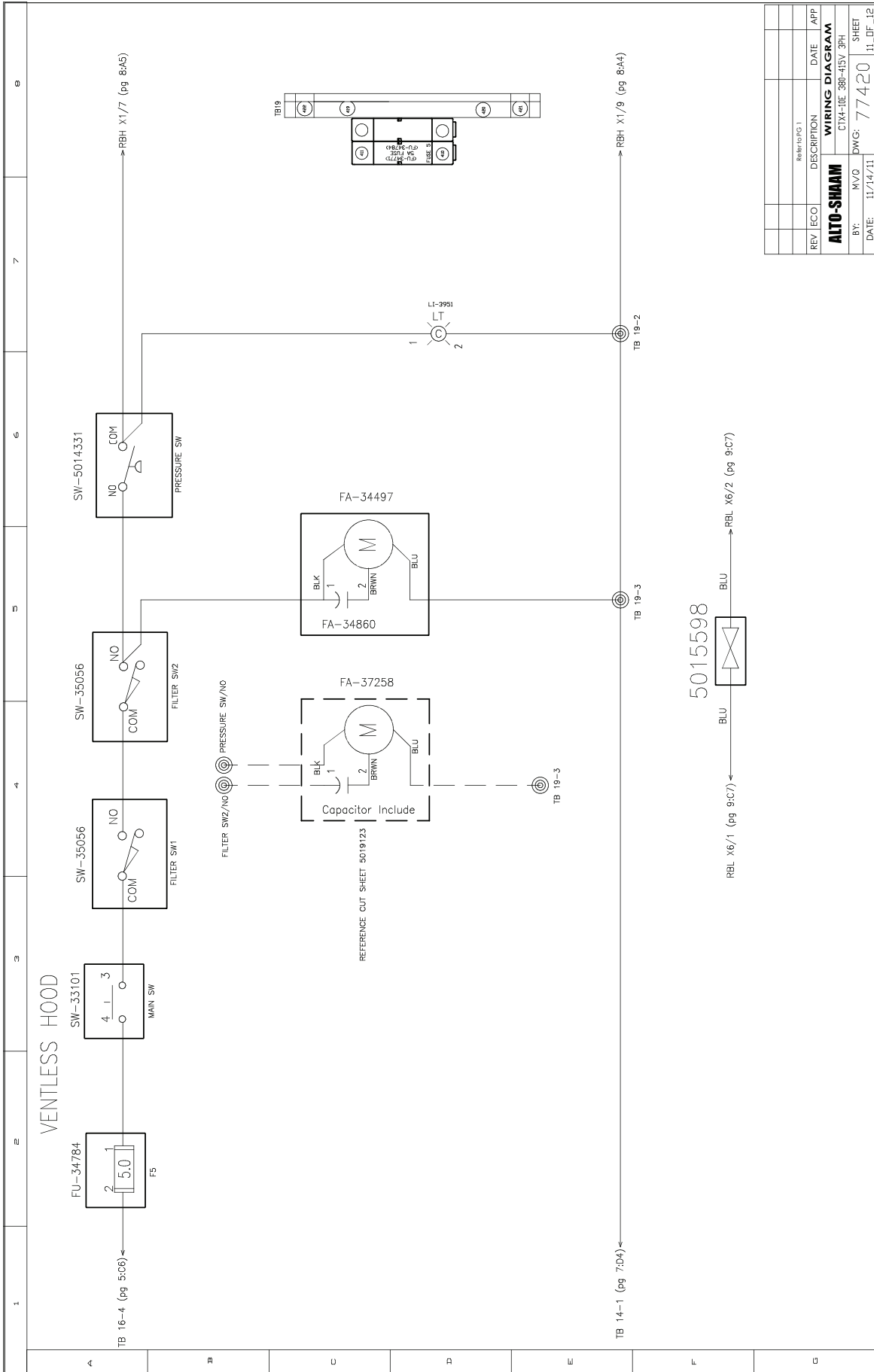

REV	ECO	DESCRIPTION	DATE	APP
Refer to PG 1				
WIRING DIAGRAM				
AUTO-SHAAM				
BY:	M.V.O			SHEET
DATE:	11/14/11	DWG:	77420	11_DF_12

WIRING DIAGRAMS

