

AMERICAN RANGE

QUALITY COOKING EQUIPMENT

PROFESSIONAL QUALITY COOKING EQUIPMENT

OWNER'S MANUAL FOR **MONGOLIAN BARBEQUE GRILL**

MODEL NUMBERS:

AMBG-36, AMBG-42, AMBG-48, AMBG-50, AMBG-60



DESIGN



CLASS



FUNCTION



DESIGNED & BUILT IN USA
PROFESSIONAL COOKING EQUIPMENT

FOR
YOUR
SAFETY

FOR YOUR SAFETY!

Do not store or use gasoline or
other flammable vapors or liquids
in the vicinity of this or any other appliance.

FOR
YOUR
SAFETY

WARNING

IMPROPER
INSTALLATION

WARNING!

Improper installation, adjustment, alteration, service
or maintenance can cause property damage, injury
or death and will void warranty. Read the
installation, operating and maintenance instructions
thoroughly before installing or servicing this equipment.

WARNING

IMPROPER
INSTALLATION

IMPORTANT SERVICE NOTICE!

Using any part other than genuine American Range factory supplied
parts relieves the manufacturer of all liability.
American Range reserves the right to change product design and
specifications without notice. Such revisions do not entitle the buyer
to corresponding changes, improvements, additions or replacements
for the previously purchased equipment.

Instructions to be followed in the event the user smells gas should be posted
in a prominent location. This information should be obtained by
consulting the local gas supplier.

RETAIN THIS MANUAL FOR FUTURE REFERENCE.

This equipment is design engineered for commercial use only.

Model Number: _____

Serial Number: _____

Purchase Date: _____

Installed By: _____ Install Date: _____

Gas Type: _____

Electrical Information: _____



PROFESSIONAL QUALITY COOKING EQUIPMENT

To Our Most Valued Customer:

Congratulations on your purchase of an American Range product. We hope you will enjoy the design, manufactured quality, innovative features and cooking performance of this product – it represents our continuing dedication to satisfying the most demanding needs of customers like you.

Please read this manual and become familiar with important safety information about how to install and set-up the unit, basic operating instructions, and how to maintain that just-like-brand-new appearance and performance - over years of day-to-day use.

If you should encounter any sort of problem, turn to the section of the manual entitled, “Troubleshooting” – for a quick solution or guidance regarding the next step required to get back to tip-top condition.

Thank you for choosing an American Range product for your kitchen. As you can expect, this appliance is designed for years of reliable service. If you have any questions or comments, please contact the dealer from whom you purchased the unit, or contact American Range Customer Service via email: info@americanrange.com at www.americanrange.com, or call 888.753.9898.

Sincerely,

Shane Demirjian

President, American Range Corporation



Intertek Intertek

13592 Desmond St., Pacoima, CA 91331 818.897.0808 tel 888.753.9898 toll free www.americanrange.com



Table of Contents

GENERAL 1

 Important Safety Information 1

 Shipping Damage Claim Procedure 1

INSTALLATION 1-3

 Instructions 1

 Gas Standards and Codes 2

 Gas Connection 2

 Manual Shut-Off Valve 2

 Rating Plate 3

 Clearances 3

OPERATING 3-4

 Check for Gas Leaks 3

 Lighting 4

 Shut Down 4

MAINTENANCE 5-6

 AMBG-36, AMBG-42, AMBG-48, AMBG-50, AMBG-60 5

 TroubleShooting Guide 6

 Wiring Diagram 6

EXPLODED VIEW DRAWINGS/PARTS LISTS 7

 AMBG-36 7

IMPORTANT

Installation of the equipment should be performed by qualified, certified, licensed and/or authorized personnel who are familiar with the functions of the equipment and experienced with state/local installation codes.

Operation of the equipment should be performed by qualified or authorized personnel who have read this manual and are familiar with the functions of the equipment.

Service of the equipment should be performed by qualified personnel who are knowledgeable with American Range equipment.

SHIPPING DAMAGE CLAIM PROCEDURE

The equipment is crafted and inspected carefully by skilled personnel before leaving the factory. The transportation company assumes full responsibility for the safe delivery upon acceptance of the equipment.

If you receive a damaged product, immediately contact your delivery company, your dealer, your builder or installer. Do not install or attempt to operate a damaged appliance.

1. Note any visible loss or damage on the freight bill or express delivery and have the note signed by the person making the delivery.
2. File claim for damages immediately regardless of the extent of damages.
3. For damage noticed after unpacking (concealed loss or damage), notify the transportation company immediately and file a "Concealed Damage" claim with them. This should be done within fifteen (15) days from the date that delivery is made to you. Retain the shipping container for inspection.

CALIFORNIA PROPOSITION 65 WARNING

The burning of gas cooking fuel generates some by-products which are on the list of substances known by the State of California to cause cancer or reproductive harm. California law requires businesses to warn customers of potential exposure to such substances. To minimize exposure to these substances, always operate this unit according to the Owners Manual, ensuring you provide proper ventilation when cooking with gas.

INSTALLATION INSTRUCTIONS

The gas pressure regulator provided with the equipment must be installed when the appliance is connected to the gas supply.

The area around the appliance must be kept free and clear of combustibles such as solvents, cleaning liquids, brooms, rags, etc.

Proper clearances must be provided at the front of the appliances for servicing and proper operation.

Provisions shall be incorporated in the design of the kitchen, to ensure an adequate supply of fresh air and adequate clearance for air openings into the combustion chamber, for proper combustion and ventilation. For proper operation of the appliance, do not obstruct the flow of combustion and ventilation air.

The installation must conform with local codes, or in the absence of local codes, with the national fuel gas code, ANSI Z223.1 - 1988 (or latest addenda).

The appliance and its individual shut off valve must be disconnected from the gas supply piping system during any pressure testing of that system in excess of 1/2 PSI.

The appliance must be isolated from the gas supply piping system by closing its individual manual shut off valve during any pressure testing of the gas supply piping system at test pressures equal to or less than 1/2 PSI.

The gas supply line must be at least 3/4" NPT.

INSTALLATION - GAS STANDARDS AND CODES

IMPORTANT - The installation of this appliance must conform to local codes or, in the absence of local codes, with the National Fuel Gas Code ANSI Z223.1, Natural Gas Installation Code CAN/CGA-B149-1, or the Propane Installation Code CAN/CGA-B149-2 as applicable, including:

1. The appliance and its individual shut off valve must be disconnected from the gas supply piping system during any pressure testing of that system at test pressure in excess of 1/2 psi (3.45 kPa).
2. The appliance must be isolated from the gas supply piping system by closing the individual manual shut-off valve during any pressure testing of the gas supply piping system.

GAS CONNECTION - The gas inlet line size of this appliance is 3/4" NPT. For proper operation, the gas supply service line must be the same size or greater than the inlet line size of the appliance. The gas line size must not be reduced at any point along the supply line.

MANUAL SHUT-OFF VALVE - A gas pressure regulator and a contractor-supplied shut-off valve must be plumbed in the gas service line ahead of the appliance – in a physical location where it can be reached quickly in the event of an emergency.

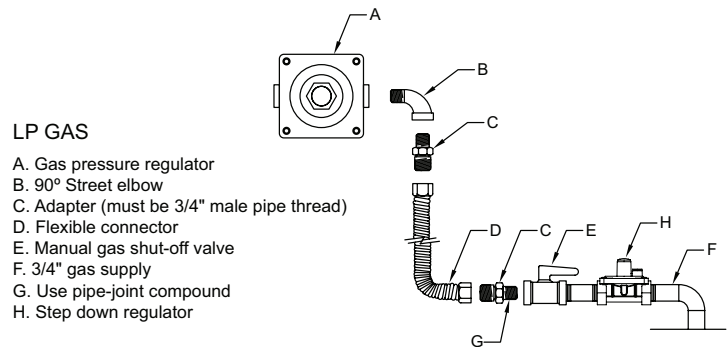
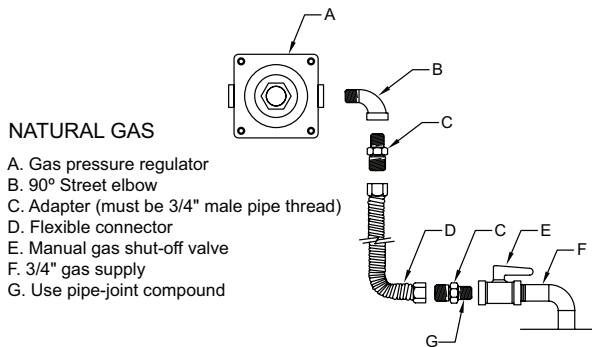

WARNING

When installing the pressure regulator - remember it can only handle 1/2 PSI. In every LPG installation, you have high source pressures, ranging from 20 PSI to 100 PSI. If the high pressure gas line from the LPG tank is directly connected to the unit without the proper step-down regulator, it will rupture the diaphragm in the valve, rendering it useless.

Visually double check any installer-supplied intake pipes and/or blow them out using compressed air to clear any dirt or debris, threading chips, or other foreign matter – before installing a service line. Those particles will clog gas orifices when gas pressure is applied. Compounds used on threaded joints of this appliance piping must be resistant to the action of NG and LP gas and provide a gas tight seal to prevent leaks.

The gas pressure regulator must be installed in the gas line – failure to install a pressure regulator will void the equipment warranty. The regulators supplied with ranges have 3/4" NPT connections; the regulator is adjusted at the factory for 5" W.C. (water column) manifold gas pressure (natural gas) or 10" W.C. manifold gas pressure for propane gas operation.

Before connecting the regulator, check the incoming line pressure – as these regulators can only withstand a maximum inlet pressure of 14" W.C. (1/2 PSI); exceeding this pressure will damage them. If the gas supply line pressure is greater than this amount, a step-down regulator will be required. A gas flow direction arrow is cast into the body of the regulator to minimize installation error – it should point downstream to the appliance. The blue air vent cap on the top of the regulator is part of the regulator and should not be removed.

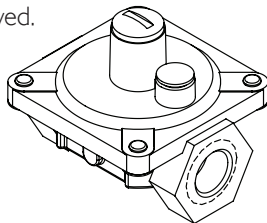

Any adjustment to the regulator must be made only by qualified and licensed service personnel with the proper calibrated test equipment. Gas connections should be performed by a qualified licensed contractor.

RATING PLATE - The information on the rating plate defines the model, serial number, gas type (natural or liquid propane), operating pressures and burner BTU ratings. It is essential for proper identification of the unit when requesting additional information or factory support.

 13592 DESMOND ST., PACOIMA, CA 91331				
MODEL: AMBG		SERIAL NO. XXXXXXXX-XXX		Intertek 3013256 Intertek
GAS TYPE: NAT		MAN. PRESS: 5.0 IN. W.C.		
INPUT-BTU/HOUR/BURNER		LEARANCES NON-COMB. COMB.		
3-RING BURNER 125,000		BACK 0"	SIDES 0"	X X
FOR USE ONLY ON NONCOMBUSTIBLE LOCATIONS ONLY. INTENDED FOR OTHER THAN HOUSEHOLD USE. ANSI Z83.11a/CSA 1.8a-2007 Food Service Equipment				

Rating Plate



WARNING

Appliances must be connected only to the type of gas specified on the rating plate.

MODEL	CLEARANCES			
	NON-COMBUSTIBLE WALLS		COMBUSTIBLE WALLS	
	Rear	Sides	Rear	Sides
AMBG-36	0"	0"	7"	8"
AMBG-42	0"	0"	7"	8"
AMBG-48	0"	0"	7"	8"
AMBG-60	0"	0"	7"	8"

X For installation on a non-combustible counter/floor only.

OPERATING INSTRUCTIONS

Before lighting, check all joints in the gas supply line for leaks. **DO NOT USE AN OPEN FLAME TO CHECK FOR LEAKS!** Use soap and water solution.

GAS LEAKS - CHECK OPERATION

1. Turn pilot valves to OFF position by turning adjustment screws clockwise.
2. Turn ON the manual gas valve at the inlet side of the gas supply line.
3. Check for gas leaks at the flexible coupling or gas connector fitting using a solution of one part soap and three parts water.
4. Sparingly spray or brush the soapy solution at the gas fittings; active bubbling indicates location of gas leak.

If a gas leak is detected turn off the manual gas valve at the inlet side of the gas line. Call your certified and licensed service technician.

5. Turn pilot adjustment screw counter-clockwise, then light standing pilot and adjust flame 1/4" high.
6. Turn ON gas valve/thermostat to light main burners.
7. For complete shut down, shut off gas valves and turn pilot adjustment screw clockwise to shut off gas to the pilots.

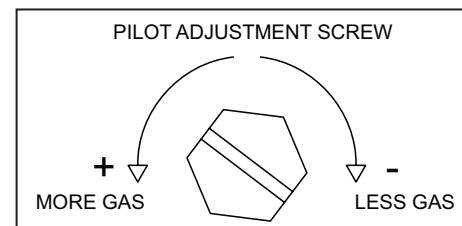

Lighting and Shut Down Instructions

Always use the following lighting and shutdown instructions below when operating your Mongolian Barbeque Grill.

A 5 minute complete shut off period is required before lighting or relighting a Mongolian Barbeque Grill. See diagrams on page 5.

1. Before allowing gas to flow to the Mongolian Barbeque Grill, ensure all gas valves are OFF by turning each handle clockwise. Check for leaks using soapy water or another suitable leak detector. **Dont use an open flame for testing.**
2. Use a gas match to light the burner pilots. See figure 1.
3. Main burner valves shall be in off position. An ignition port is provided for each pilot burner. Use a flashlight to locate each prior to lighting it is recommended one person light the pilots and the second to locates and holds the red button on each safety control.
4. Starting at grease drawer access door; insert the ignited lighter through the ignition port and light the pilot burner as you push and hold the red button on the safety control.

~~On initial startup, allow 1/2 to 1 minute for air trapped in the gas lines to bleed while holding the safety control ignition button. A qualified gas service technician can bleed the line from the pressure test port. It is located on the manifold to the right of the front access door.~~

Lighting Instructions

1. Before attempting to light this appliance, the door if so equipped, shall be open.
2. Turn the appliance manual gas shut-off valve to the OFF position.
3. Turn the combination gas control knob to the OFF position.
4. Turn the control to the OFF position.
5. Wait 5 minutes.
6. Turn the appliance manual gas shut-off valve to the ON position.
7. Turn the combination gas control knob to the PILOT position.
8. Light the pilot with a match while depressing and holding the combination gas control knob until the pilot remains lit upon releasing the gas control knob.
9. Turn the combination gas control knob to the ON position
10. Turn the main valve control to the desired setting to turn burners ON.
11. Ensure tha the door if so equipped is closed during operation.
12. For complete shut-down, repeat steps 2,3 and 4.

IMPORTANT

- The natural gas unit is designed for 5" W.C. operational pressure. A minimum of 7" W.C. must be maintained or performance of the unit will not meet specifications. The propane unit is designed for 10" W.C. operational gas pressure at the outlet. A minimum of 12" W.C. must be maintained or performance of the unit will not meet specifications.
- There is 1/8" test tap in the front right section of the manifold behind the access door. Using a manometer or similar device, operating pressure should be verified.

Operating Instructions

1. The top should come to full operating temperature in approximately 60 minutes after all burners have been lit. Use a high temperature thermometer to verify the cook surface has reached a minimum operating temperature of 500°F.
2. When the unit reaches operating temperature turn OFF every other burner. The burners on the Mongolian Barbeque Grill AMBG-36, AMBG-42, AMBG-48 and AMBG-60 are sufficient to maintain operating temperature except during extremely busy cycles when additional burners may be necessary.

Operational Overview

The Mongolian Barbeque Grill is a high performance griddle-style units. Multiple burners are equally spaced under the top with individual valves and safety controls. Depending on the size of the top up to four chefs can cook simultaneously as they sauté vegetables, fish, meat and poultry as guests watch. The Mongolian Barbeque Grills are similar to a tepanyaki griddle but much more powerful.

Seasoning

The first time you use the unit the top must be seasoned. This must be done while the ventilation system is operating. Wash the top with soapy water to remove all grease and oil from the manufacturing process. Rinse the top immediately. Using the procedure described earlier; fire up the unit and get the top hot.

Turn down the heat and wipe the surface with a towel coated with cooking oil. With repeated heating and wiping, the top will attain a non stick finish. Do not use soap again to clean the top but rather a griddle scraper to keep the top free from carbon build-ups.

Cooking

This unit is similar to a high-speed griddle. Intense heat generated by the burners heats the tops to achieve the searing temperatures of wok-style cooking. Techniques similar to stir-fry are used.

Like a wok or cast iron fry pan the Mongolian Barbeque Grill top must be re-seasoned periodically. Food should not be allowed to remain on the top as this will cause the top to pit or otherwise deteriorate.



Do not pour cold water on the top while still hot, could damage or warp the cooking surface.

TROUBLESHOOTING GUIDE

POSSIBLE CAUSE	SUGGESTED ACTION
SYMPTOM: Burners do not come on.	
Unit is not connected to gas service	Visually check unit is plumbed to gas
Pilot is not burning	Light pilot
Burner not burning high	Set valve to desired setting
SYMPTOM: Grill not getting hot enough.	
Unit may not have been operating long enough	Unit preheats to 350°F in about ten minutes on high setting
Safety valve may be defective	Unit will require service
Too little gas pressure, dirty gas line	Call for authorized service
SYMPTOM: General cooking problems.	
Temperature too low or too high	Set unit to desired setting.
Safety valve not working	Unit will require service

WARNING

Always disconnect the gas service before cleaning or servicing the griddle.

WIRING DIAGRAM

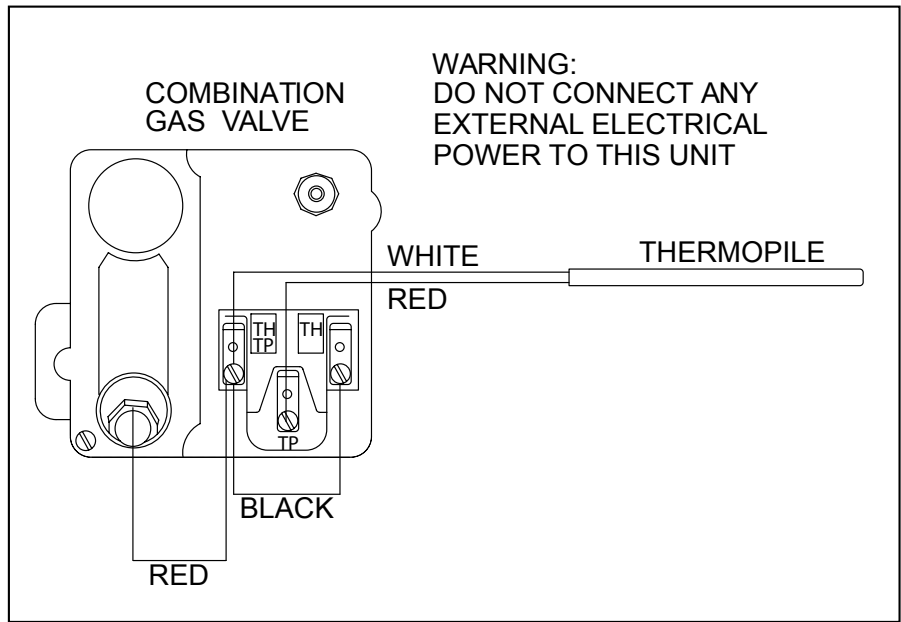

ITEM NO.	PART NO.	DESCRIPTION
2	A99831	Grease Tray
3	A44003	Nut, Speed #6 Push Black 10601
4	A38000	Name Plate, American Range 8" 10499 Quality Commercial Chrome
7	A32108	Handle, Gas Valve ARSP-J, ARWR-J 10493
8	A80106	Valve, Gas Ball 1/2" x 1/2" AESP 10492
11	A80102	Valve, Gas AF-Series NAT Gas 11114
	A80103	Valve, Gas AF-Series LPG Gas 11114
12	A11103	Pilot, AF 6CH14-6N .018 Nat Gas 11105
	A11121	Pilot, AF 6CH14-6 .014 LPG Gas
13	A14034	Burner, Jet 23 Tip #63 Hood Na Gas 10478N
	A14035	Burner, Jet 23 Tip #73 Hood LPG Gas 10478L
15	A11102	Thermopile, Power Generator 11109

MONGOLIAN BARBEQUE - PARTS

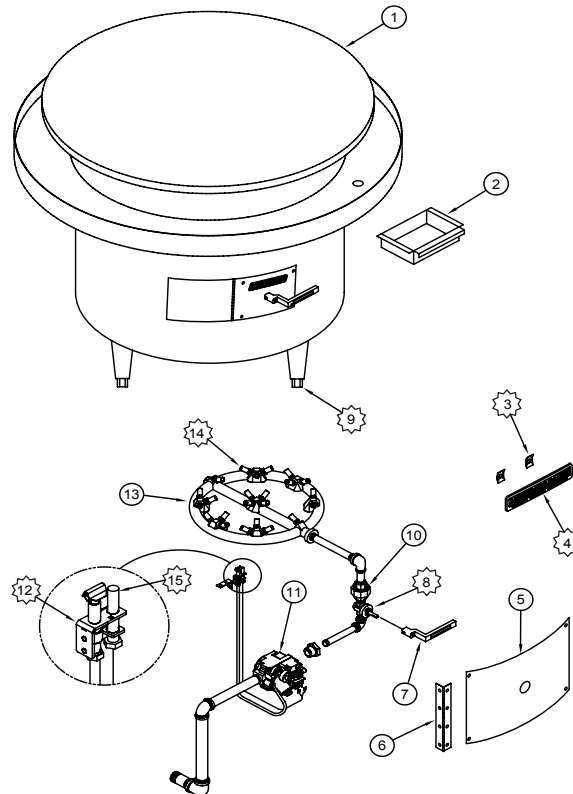
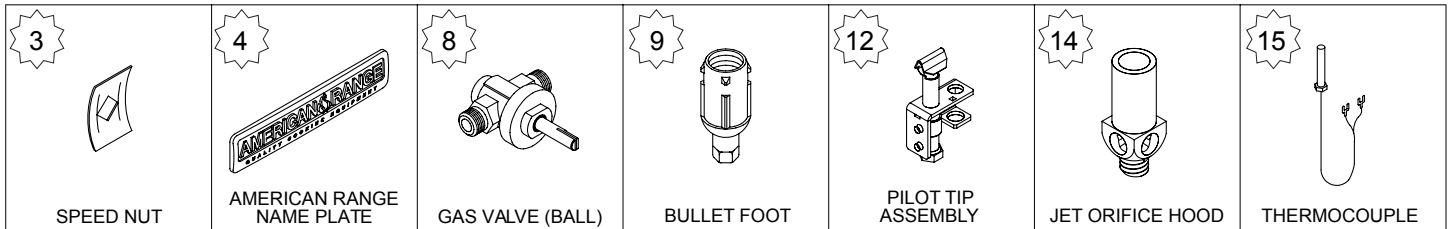

WARRANTY REQUIREMENT

For reliable operation and for your own safety, this professional cooking equipment must be installed by a certified/licensed contractor.

Failure to comply will void any written or implied warranty.

Should the equipment require service during the standard warranty period, the receipt proving certified installation must be made available to American Range for verification.

If installation was not performed by a certified/licensed contractor be prepared to submit a major credit card for payment for proper installation prior to service.



13592 Desmond Street, Pacoima, CA 91331
818.897.0808 888.753.9898 tel
818.897.1670 fax
www.americanrange.com