



PROFESSIONAL QUALITY COOKING EQUIPMENT

USE AND CARE MANUAL FOR
MEDALLION DUAL FUEL RANGES

MODEL NUMBERS: ARR-304DF, ARR-364GDDE, ARR-366DF, ARR-364GRDF,
ARR-486GDDE, ARR-484X2GRDF, ARR-486GDGRDF, ARR-4842GDDE, ARR-486GRDF,
ARR-606GDGRDF, ARR-6062GDDE, ARR-60X2GRDF



DESIGN CLASS FUNCTION

RETAIN THIS MANUAL FOR FUTURE REFERENCE

FOR YOUR SAFETY!
Do not store or use gasoline or other flammable vapors or liquids in the vicinity of this or any other appliance.

WARNING
IMPROPER
INSTALLATION

WARNING!
Improper installation, adjustment, alteration, service or maintenance can cause property damage, injury or death and will void warranty. Read the installation, operating and maintenance instructions thoroughly before installing or servicing this equipment.

WARNING
IMPROPER
INSTALLATION

IMPORTANT SERVICE NOTICE!
Using any part other than genuine American Range factory supplied parts relieves the manufacturer of all liability.
American Range reserves the right to change specifications and product design without notice. Such revisions do not entitle the buyer to corresponding changes, improvements, additions or replacements for the previously purchased equipment.

Instruction to be followed in the event the user smells gas should be posted in a prominent location. This information should be obtained by consulting the local gas supplier.

RETAIN THIS MANUAL FOR FUTURE REFERENCE.

This equipment is design engineered for commercial use only.

Model Number: _____

Serial Number: _____

Purchase Date: _____

Installed By: _____ Install Date: _____

Gas Type: _____

Electrical Information: _____



PROFESSIONAL QUALITY COOKING EQUIPMENT

To Our Most Valued Customer:

Congratulations on your purchase of an American Range product. We hope you will enjoy the design, manufactured quality, innovative features and cooking performance of this product – it represents our continuing dedication to satisfying the most demanding needs of customers like you.

Please read this manual and become familiar with important safety information about how to install and set-up the unit, basic operating instructions, and how to maintain that just-like-brand-new appearance and performance - over years of day-to-day and special holiday use.

If you should encounter any sort of problem, turn to the section of the manual entitled, “Troubleshooting” – for a quick solution or guidance regarding the next step required to get back to tip-top condition.

Thank you for choosing an American Range product for your home. As you can expect, this appliance is designed for years of reliable service. If you have any questions or comments, please contact the dealer from whom you purchased the unit, or contact American Range Customer Service at www.americanrange.com or 818.897.0808.

Sincerely,

Shane Demirjian

President, American Range Corporation



Table of Contents

GENERAL..... 1-5
 General Information 1
 About This Manual 2
 Shipping Damage Claim Procedure..... 3
 Precautions..... 3-5

INSTALL..... 6-14
 Site Preparation 6
 Electrical Connection 6
 Gas Connection 6
 Model Numbers..... 7
 Installation Diagrams..... 8-9
 Cabinet Preparation..... 9
 Electrical Service 10
 Gas Supply 10
 Preparation for Installation..... 10
 Model and Parts Identification..... 11
 Final Installation..... 12
 Before Using the Appliance 12
 Installation Checklist..... 13
 Performance Checklist..... 14
 Start-up Procedure..... 14

OPERATE..... 15-21
 Cook Top..... 15
 Cookware 16
 Suggested Burner Settings..... 16
 Control Panel/Keys..... 17
 Ovens..... 18
 Control Panel..... 19
 Sabbath Mode 19
 Grill 20
 Griddle..... 21

MAINTAIN 22-24
 Self-Cleaning..... 22
 Cleaning Stainless Steel, Glass 22
 Care & Cleaning..... 23-24
 Cleaning Recommendations 24

TROUBLESHOOT 25

WARNING

If the information in this manual is not followed exactly, a fire or explosion may result causing damage, personal injury or death.

- INSTALLATION AND SERVICE MUST BE PERFORMED BY A CERTIFIED / LICENSED INSTALLER, SERVICE AGENCY OR THE GAS SUPPLIER
- Do not store or use gasoline or other flammable vapors or liquids in the vicinity of this or any other appliance.

- WHAT TO DO IF YOU SMELL GAS
 - Do not try to light any appliance.
 - Do not touch any electrical switch, do not use any phone in your building.
 - Immediately call your gas company. Follow the gas supplier instructions.
 - If you cannot reach your gas supplier, call the Fire Department.

WARRANTY REQUIREMENT

For reliable operation and for your own safety, this professional cooking equipment must be installed by a certified/licensed contractor.

Failure to comply will void any written or implied warranty.

Should the equipment require service during the standard warranty period, the receipt proving certified installation must be made available to American Range for verification.

If installation was not performed by a certified/licensed contractor be prepared to submit a major credit card for payment for proper installation.

- Please observe all local and national codes and ordinances.
- Do not remove any permanent warning labels or plates from this product.
- Please ensure that this product is electrically grounded.
- Consumers should retain these instructions for local inspectors and for future use.

- The included Anti-Tip Device must be installed prior to operation

ABOUT THIS MANUAL

The Use and Care Manual is divided into several sections:

The Safety Section informs you about significant safety precautions when installing and operating your new fryer. This is a must read section of the manual.

Quick Start and Installation Section describes how to unpack the unit, what to save and what to discard, installation dimensions, gas and electrical connections and how to identify the primary parts of the product so you can better understand what's going on "under the hood".

How to Use Your Product and How to Use the Oven (where applicable) Sections show you how to light the burners, set the range for broil or bake and how to use convection to speed cooking times and improve the quality of your baked and roasted dishes.

The Care and Maintenance and Troubleshooting and Service Sections discuss how to keep your product in good operating condition, how to identify what might be going wrong with the unit, and how to communicate your observations with authorized field service technicians.

Before using your appliance, please read this manual paying special attention to the important safety instructions located in the next several pages.



This is the SAFETY ALERT SYMBOL. This symbol alerts you to hazards which will result in severe injury or death.



DANGER

Hazards or unsafe practices which will result in severe personal injury or death.



WARNING

Hazards or unsafe practices which may result in severe personal injury or death.



CAUTION

Hazards or unsafe practices which may result in minor personal injury or property damage.

CALIFORNIA PROPOSITION 65 WARNING

The burning of gas cooking fuel generates some by-products which are on the list of substances known by the State of California to cause cancer or reproductive harm. California law requires businesses to warn customers of potential exposure to such substances. To minimize exposure to these substances, always operate this unit according to the Owners Manual, ensuring you provide proper ventilation when cooking with gas.

PRECAUTIONS

SHIPPING DAMAGE CLAIM PROCEDURE

The equipment is crafted and inspected carefully by skilled personnel before leaving the factory. The transportation company assumes full responsibility for the safe delivery upon acceptance of the equipment.

If you receive a damaged product, immediately contact your delivery company, your dealer, your builder or installer. Do not install or attempt to operate a damaged appliance.

1. Note on the freight bill or express delivery any visible loss or damage and have the note signed by the person making the delivery.
2. File claim for damages immediately regardless of the extent of damages.
3. For damage noticed after unpacking (concealed loss or damage), notify the transportation company immediately and file a "Concealed Damage" claim with them. This should be done within fifteen (15) days from the date that delivery is made to you. Retain the shipping container for inspection.

CAUTION

Check your local building codes for proper installation methods. In the absence of local codes, this appliance should be installed in accordance with the National Fuel Gas Code No. Z223.1 current issue, and the National Electrical Code ANSI/NFPA No. 70 current issue, or the CAN – B149 Installation Codes for Gas Burning Appliances, and C22.1 Canadian Electrical Code Part I. Verify the type of gas supplied to the location, being sure that the appliance is connected to the type of gas for which it is certified. Models come from the factory certified for use with Natural Gas (NG) or Liquid Propane (LP) gas. Your product, shown on the rating label and the supplied gas type must be the same. Upon opening your product, the rating label can be located on the front panel if it is a range or oven. If it is a cook top it can be found on the side panel underneath the left burner.

Your appliance must be installed by a qualified gas installation technician. Have the technician show you the exact location of the gas shut-off valve on the incoming gas line so you know how to turn off the gas if necessary.

If connecting this appliance to propane gas, make certain the propane gas tank is equipped with its own high-pressure regulator - in addition to the pressure regulator supplied with this product when applicable. The maximum propane gas pressure to this appliance must not exceed 14.0 inches of water column (34.9 millibar) from the propane gas tank to the pressure regulator.

CAUTION

For personal safety, this appliance must be connected to a properly grounded and polarized electrical power supply. If only a two-prong outlet is available, it is the customer's responsibility to have it replaced with a dedicated, grounded, three-prong electrical outlet by a licensed technician. The gas surface burner re-ignition system when applicable depends on a low resistance electrical ground connection for reliable operation.

- Do not cut or remove the third (ground) prong from the power cord
- Do not use an adapter plug
- Do not use an extension cord
- Do not use a power cord that is frayed or damaged
- Do not plug the appliance into an electrical outlet with a Ground Fault Circuit Interrupter (GFCI)

 **DANGER**

To avoid the possibility of explosion or fire, do not store or use combustible, flammable or explosive liquids (such as gasoline) or vapors inside or in the vicinity of this or any other appliance. Keep items that could explode, such as aerosol cans, away from the product. Do not store explosive or flammable materials in nearby cabinets or areas. When operating the oven or broiler, do not touch the surfaces of the ceramic tile broiler, the rack or rack supports, the walls of the oven or the inside surfaces of the oven door - interior surfaces become hot enough to cause burns. The heat deflector, which deflects heat away from the control panel, and the oven door sides will also be hot during use.

 **DANGER**

Do not store items of interest to children above or near the appliance. Children, as well as adults, should never be allowed to sit, stand or climb on any part of the appliance. Serious personal injury may occur.

 **WARNING**

Always disconnect the electrical plug from the wall outlet before servicing the unit. It is recommended that a dedicated electrical circuit be used for this appliance.

Always turn gas shut-off valve to OFF position before servicing unit.

 **WARNING****POWER FAILURE WARNING**

Due to safety considerations and the possibility of personal injury, do not attempt to light or operate range burners, grills, griddles, the oven or broiler during a power failure. Safety systems which detect the presence of an ignition source and operate the gas safety valve do not function during a power failure. Be sure all gas valve knobs are turned to and remain in the OFF position during a power failure.

IMPORTANT SAFETY NOTICE AND WARNING

The California Safe Drinking Water and Toxic Enforcement Act of 1986 (Proposition 65) requires the Governor of California to publish a list of substances known to the State of California to cause cancer or reproductive harm, and requires businesses to warn customers of potential exposures to such substances. Users of this appliance are hereby warned that when the oven is operated, there may be some low-level exposure to some of the listed substances including carbon monoxide. Exposure to these substances can be minimized by properly venting the oven to the outdoors using approved overhead ventilation equipment or by opening the windows and/or doors in the room where the appliance is located.

This appliance should not be operated without a properly sized and functional ventilation hood.

 **WARNING**

To reduce the risk of appliance tipping, it must be secured to the wall with a properly installed anti-tip bracket. To make sure the bracket has been installed properly, inspect behind the range using a flashlight.

- Anti-tip devices are only necessary for range products.
- This range can tip causing personal injury
- See Installation Instructions supplied with the range and install the anti-tip device packaged with the range
- If the anti-tip device cannot be located, contact American Range Customer Service by calling 818.897.0808 or by contacting us at www.americanrange.com

 **CAUTION**

Purchase a kitchen fire extinguisher for your home and store it in close proximity to your appliance. Should an uncontrolled fire occur, never use water on grease fires. Never pick up a flaming pan. The oven door interior and exterior, especially the oven door glass can get hot during operation. Do not touch the glass – use the door handle to open or close the range door.

The push-to-turn gas valve knobs on the appliance are designed to be child-safe, however, they are not a guarantee of operation. Children should not be left alone or unattended in the kitchen while the appliance is in use. Never leave the appliance unattended during use. Boil-overs may occur, causing spills which may ignite.

Never wear loose fitting or long sleeved apparel while cooking. Never wear garments made of flammable materials. Clothing may ignite or catch utensil handles. **DO NOT** drape towels or other items on door handles. These items could ignite and cause burns.

If your product is a range or oven **ALWAYS** place oven racks in the desired position before you start cooking and while the oven is cool. Always use dry and sturdy pot-holders to carefully slide the oven rack out to add or remove food.

If your product is a range or cooktop located near a window, be certain window curtains or other flammable objects do not blow over or near the range burners; the items could catch on fire.

If operating the surface burners, the flame should be adjusted to just cover the bottom of the pan or pot. Excessive high flame settings may cause scorching of the nearby counter-top surface, as well as the outside of the utensil and handles.

ALWAYS turn the appliance off at the end of cooking.

When dehydrating food items, periodically check during the process to ensure that they do not catch on fire.

If you are “flaming” liquor or other spirits under an exhaust, **TURN THE FAN OFF**. The draft from the fan could cause the flames to spread out of control.

Care should be exercised if your appliance is equipped with a high-shelf. During heavy or continuous use, this shelf may be come hot. Do not place combustible materials or plastic items on the shelf.

Turn the knobs to the **OFF** position prior to removing them from the valve stems for cleaning.

 **WARNING**

NEVER use this appliance as a space heater to heat or warm the room. Doing so may result in carbon monoxide poisoning and overheating of the appliance. Do not use the range top or oven as a food or kitchen item storage area.

Never block or cover any slots, holes or passages located anywhere inside or outside the range. These structures are important to safe operation of the appliance and doing so may block airflow through the oven or cook top possibly causing carbon monoxide poisoning or fire. Routinely keep all slots free of grease and other materials.

This appliance has been tested for safe performance using conventional cookware. **DO NOT USE** any device or accessory not specifically recommended in this guide. **DO NOT USE** pan or pan covers on surface units, grills or griddles. These devices can create serious safety hazards including personal injury, create performance problems and may damage the appliance.

Do not store or use corrosive chemicals, vapors, flammables or non-food products in or near this appliance. It is specifically designed for use when heating or cooking food. The use of corrosive chemicals while heating or cleaning could result in personal injury or damage to the appliance.

INSTALLATION INSTRUCTIONS

The location selected for the range must meet the following criteria. If any of these criteria are not met, select another location.

SITE PREPARATION

- The range is a free standing appliance. If the range is to be installed adjacent to cabinets, the clearances where indicated are required.
- This range may not be recessed into the cabinets. The rear of the oven door must be beyond the edge of the frontface of the adjacent cabinet.
- The gas and electrical supplies should be located below the unit or in the adjacent right cabinet.
- Any openings in the wall behind the range and in the floor under the range must be sealed.
- Always keep the appliance free and clear of combustible materials, gasoline, or other flammable vapors and liquids.
- Do not obstruct the flow of combustion exhaust and ventilation air to the unit.

ELECTRICAL CONNECTION

- The Range must be electrically grounded in compliance with local codes or, in the absence of local codes, with the National Electrical Code, ANSI/NFPA70.
- The electrical service in the building must be equipped with a properly grounded NEMA 14 - 30 receptacle.

POWER REQUIREMENTS FOR THIS RANGE

- 240 VAC, 60 Hz, single phase, 30 AMP Max

GAS CONNECTION

Be certain the appliance being installed is correct for the gas service being provided. Refer to the appliance data plate for the gas supply requirements.

A manual gas shut-off valve must be remotely installed and easily accessible in the adjacent cabinet. The regulator inlet is for a 3/4 inch gas line. The appliance ships with a 1/2 inch to 3/4 inch adapter connected to the regulator.

- Use at least a 1/2" commercial flex hose to connect range to the gas supply (service line).
- A manual gas shut-off valve must be installed, in easy access in front of the gas supply (service line) and ahead of the range for safety and ease of maintenance.
- All valves must be in the OFF position before connecting to the gas supply line.

MODEL NUMBERS

This manual covers the following models:
American Range Professional Series Dual-Fuel Ranges

ARR-304DF
ARR-366DF
ARR-436GD
ARR-436GR
ARR-486GDDF
ARR-486GRDF
ARR-4862GDDF
ARR-484X22GRDF
ARR-484GDGRDF
ARR-6062GD
ARR0606X2GR
ARR-606GDGR

IMPORTANT

Do not operate an appliance that has been misused, abused, neglected, damaged, or altered/modified from that of the original manufactured specifications.

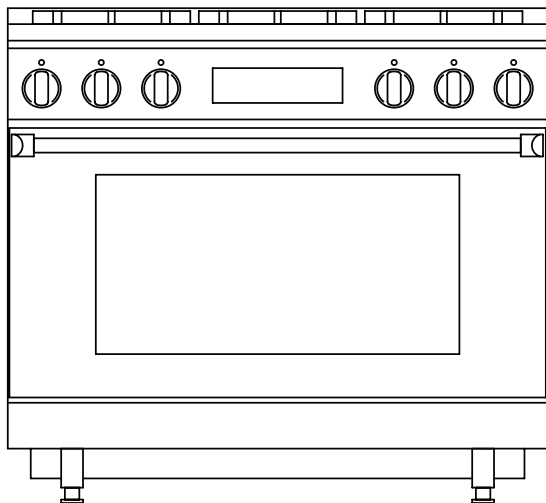

The model and serial number are listed on the data plate located under the control panel or on the kickplate on the front of the appliance.

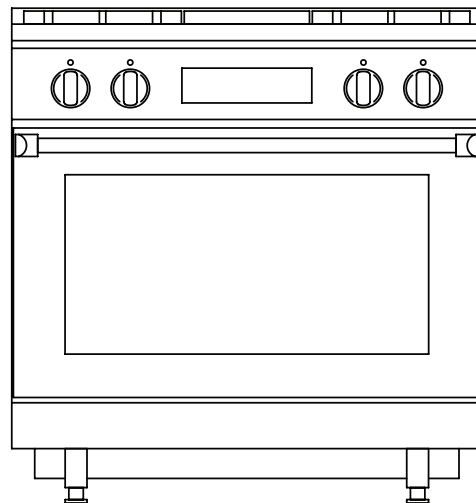

INSTALLATION INSTRUCTIONS

GENERAL

These instructions are provided to assist the qualified installer. It is the owner's responsibility to ensure that all governing codes and ordinances are observed during the planning and installation of this appliance.

IMPORTANT

Failure to follow these installation guidelines will affect warranty coverage.

OVERALL RANGE DIMENSIONS

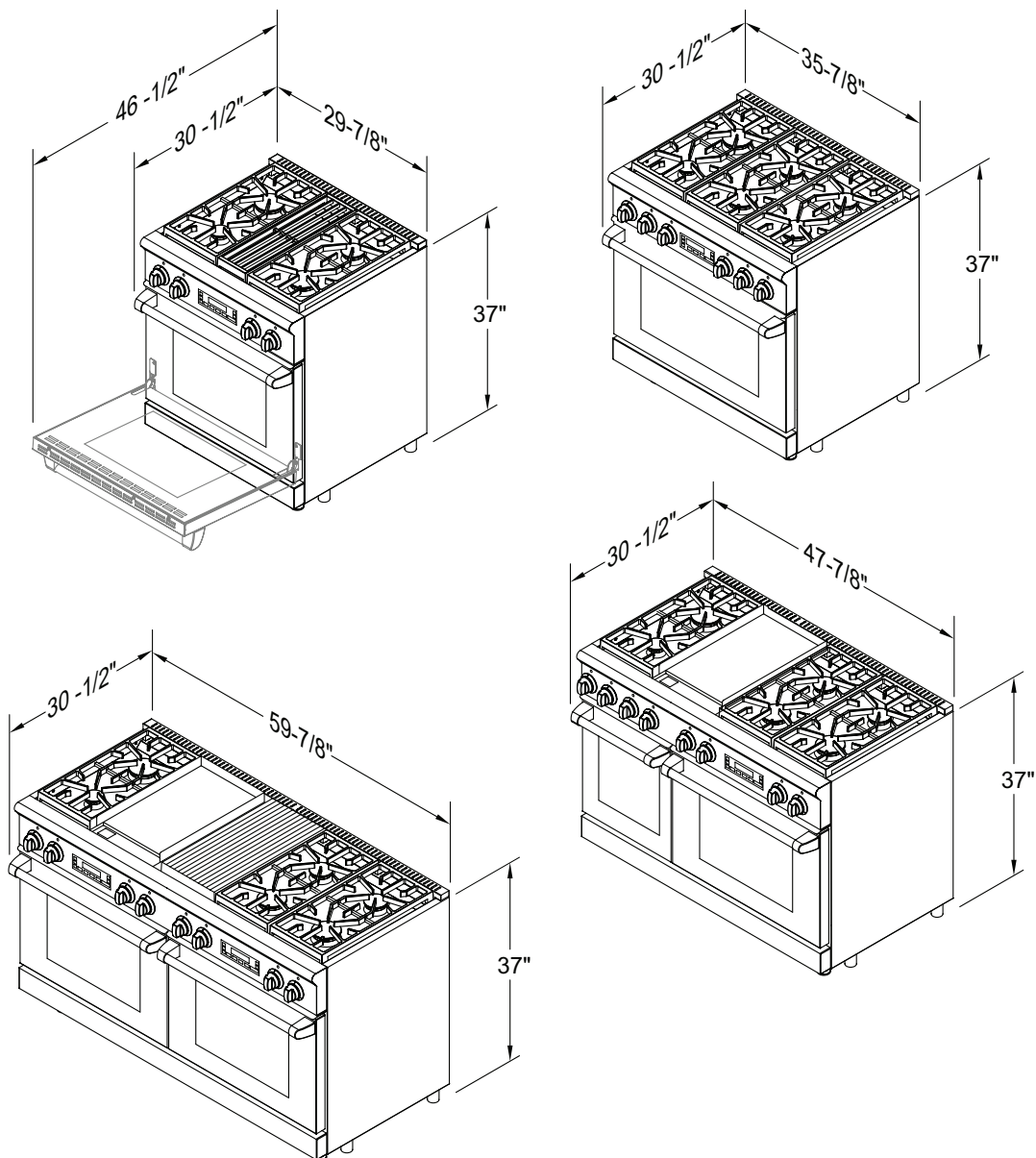

INSTALLATION INSTRUCTIONS

RANGE LOCATION

The location selected for the range must meet the following criteria. If any of these criteria are not met, select another location.

NOTE

For optimal performance, the range should be installed away from drafts that may be caused by doors, windows, and heating and air conditioning outlets.

CABINET PREPARATION

The Range is a free standing appliance. If the Range is to be installed adjacent to cabinets, the clearances shown below are required.

- This Range may not be recessed into the cabinets. The rear of the oven door must be beyond the edge of the front face of the adjacent cabinet.
- The gas and electrical supplies should be located in adjacent right cabinet.
- Any openings in the wall behind the Range and in the floor under the range must be sealed.
- Always keep the appliance clear and free from combustible materials, gasoline, or other flammable vapors and liquids.
- Do not obstruct the flow of combustion and ventilation air to the unit.

NOTE

The maximum depth of the overhead cabinets installed on either side of the hood is 13" (330).

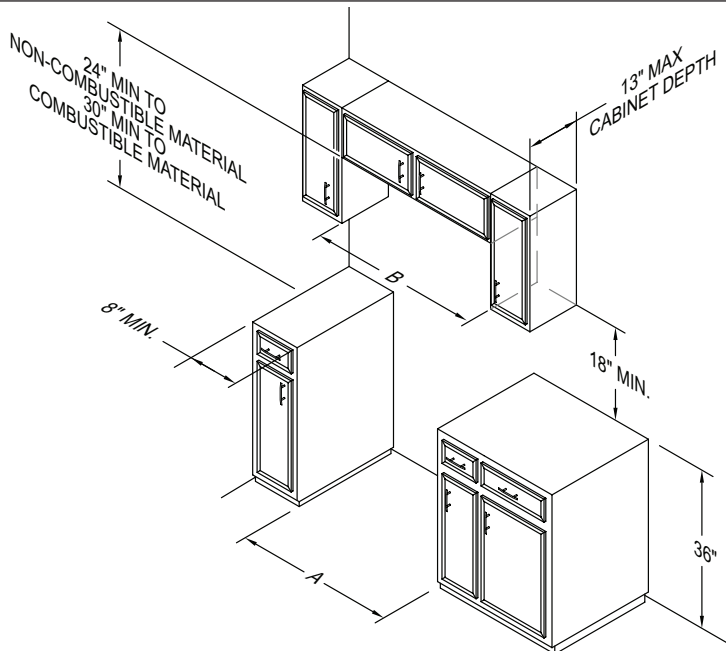

RANGE WIDTH	"A" DIMENSION	"B" DIMENSION
29-7/8"	30"	36"
35-7/8"	36"	42"
47-7/8"	48"	54"
59-7/8"	60"	66"

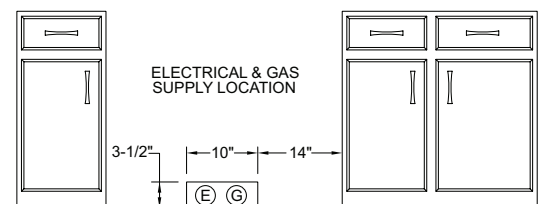

INSTALLATION INSTRUCTIONS

⚠ WARNING

It is the owner's responsibility to ensure that the electrical connection of this appliance is performed by a qualified electrician. The electrical installation must be in accordance with the latest version of the National Electrical code ANSI/NFPA 70 and local codes and ordinances.

⚠ WARNING

Check your local building codes for the proper method of installation. In the absence of local codes, this appliance should be installed in accordance with the National Fuel Gas Code ANSI Z223.1. Be certain that the appliance being installed is correct for the gas service being provided.

IMPORTANT

Within the Commonwealth of Massachusetts, this appliance must be installed by a licensed plumber or gas fitter.

⚠ WARNING

Do not attempt to disengage the hinge catch with the door removed from the oven. The hinge spring could release causing personal injury.

Do not lift or carry the oven door by the door handle.

ELECTRICAL SERVICE

A 240VAC, 60Hz separately grounded circuit that is protected by a 30A circuit breaker or time delay fuse must be supplied to the appliance.

A four-wire connection (not provided) is required to connect the appliance to the electrical supply junction box. Consult local building codes for the type and minimum wire gauge to use. The wiring to the appliance from the electrical supply junction box needs to be long enough to allow the appliance to be pulled out from the wall for service, while remaining connected.

GAS SUPPLY

Be certain that the appliance being installed is correct for the gas service being provided. Refer to the appliance data plate for the gas supply requirements.

Minimum Natural Gas Supply Required – 6" water column

Minimum Liquid Propane (LP) Gas Supply Required – 11" water column

A manual gas shut-off valve must be remotely installed and easily accessible in the adjacent cabinet.

The regulator inlet is for a 1/2" gas line.

PREPARING FOR INSTALLATION

UNPACKING THE APPLIANCE

Unpack all parts boxes and verify that all of the required components have been provided. If any items are missing or damaged, please contact your dealer immediately. Do not install a damaged or incomplete appliance.

REMOVING THE OVEN DOOR

To make the appliance easier to move, remove the door to reduce weight.

1. Open the door to its fully opened position.
2. Place hinge pin in the hole located in hinge arm.
3. Remove left and right hinge locks.
4. Move door upward to engage pin.
5. Lift door out.

CONNECTING THE ELECTRICAL SERVICE

1. Make sure that the conduit or appliance wire is long enough to allow the range to be pulled out for service without disconnecting it.
2. Connect the wires on the appliance wall electrical box.

CONNECTING THE GAS SUPPLY

1. Make sure the gas supply valve is in the OFF position.
2. Make sure all surface burner knobs are in OFF position.
3. Connect the gas line to the appliance.
4. Connect the gas line to the supply line.
5. Turn on the gas supply and check for leaks.

MODEL AND PARTS IDENTIFICATION

DESCRIPTION	MEDALLION SERIES - DUAL FUEL RANGES											
	ARR-304DF	ARR-364GDDF	ARR-366DF	ARR-364GRDF	ARR-486GDDF	ARR-484X2GRDF	ARR-486GDGRDF	ARR-4842GDDF	ARR-486GRDF	ARR-606GDGRDF	ARR-6062GDDF	ARR-60X2GRDF
Oven Racks	2	2	2	2	4	4	4	4	4	4	4	4
Sealed Burners	4	4	6	4	6	4	6	4	6	6	6	6
Center Plate	1	0	0	0	0	0	0	0	0	0	0	0
Grates	3	2	3	3	3	4	4	2	4	4	3	5
Control Knobs	4	5	6	5	7	6	8	6	7	8	8	8
Griddle	0	1	0	0	1	0	1	1	0	1	1	0
Backyard Grill	0	0	0	1	0	2	1	0	1	1	0	2
Regis. Card	1	1	1	1	1	1	1	1	1	1	1	1
U&C Manual	1	1	1	1	1	1	1	1	1	1	1	1

Oven Racks: Each oven is supplied with two heavy chrome-plated adjustable oven racks.

Rack Supports: On each side of the oven, heavy chrome-plated rack supports allow five positions, numbered from the bottom up.

Oven Control Knob: The oven control knob is used to set the Baking temperature or to select the Broil function. During baking, the convection fan may be activated.

Bake Burner: The Bake burner is located in the center of the oven, below the floor and is activated by the Oven Control Knob.

Magma Grill Infrared Broil Burner: Positioned in the oven ceiling, a highly insulated ribbon element lights up to a temperature of 1,850°F – creating searing heat similar to the glowing coals of a wood fire.

Inconel® Screen Infrared Broil Burner: This broil burner is also positioned in the oven ceiling, burning gas heats the Inconel Screen to 1,850°F, perfect for browning and crisping.

Broil Burner Igniter: The igniter glows a very hot, bright red-orange color; reaching proper ignition temperature to light the Inconel Screen Infrared Broil Burner.

Burner On Indicator Light: Whenever an oven burner is activated (either Bake or Broil), the burner on indicator will glow. It is normal for the indicator light to cycle off and on during baking or broiling – showing that the requested temperature has been achieved – or that more heat is required.

Door Gasket: The door gasket is made from high temperature materials and creates a seal between the hot oven and the cool kitchen.

Convection Fan and Switch: Operated by the front panel switch, the convection fan circulates oven air; removing the “thermal boundary layer” on items being baked – and in doing so – speeding up heat transfer and cook time by as much as 25%. Convection is active only during baking.

Oven Light and Switch: A single lamp is provided in the oven to illuminate baked and broiled food items, as well as shed some light on the wall to help during clean-up – activated by the front panel switch.

INSTALLATION INSTRUCTIONS

FINAL INSTALLATION

SLIDING THE APPLIANCE INTO THE CABINET

Make sure that the gas supply and electrical service are properly connected.
 Peel the protective coating off the appliance, if applicable.
 Carefully slide the appliance into position in the cutout. Install the anti-tip system.

LEVELING AND ADJUSTING THE APPLIANCE

To adjust the height of the Range, turn the bottom of the leg. Use a spirit level to make sure that the appliance does not tilt to the front/back or to either side. The appliance side panel must be flush with the countertop.

RE-INSTALLING THE OVEN DOOR

Grasp both sides of the oven door.
 Slide the hinges into the hinge openings, resting the bottom of the hinge arms in the hinge openings.
 Lower the door to the fully opened position.
 Remove the hinge pins on each hinge and secure hinges with hinge lock.
 Slowly close and open the oven door completely to ensure that it is properly reinstalled.

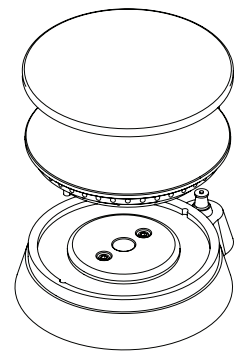

INSTALLING THE BURNER COMPONENTS

Install the burner components as shown to the right.

BEFORE USING THE APPLIANCE

- Prior to operating this appliance, please read the operation and maintenance sections of this manual.
- Before beginning the test procedure, verify that all cook top control knobs are in the OFF position. Turn on the gas supply at the manual shut-off valve.
- Turn ON each cook top burner separately by pushing in the control knob and turning it counterclockwise to the HIGH position. It may take a few seconds for ignition to occur. After ignition, rotate the control knob counterclockwise from HIGH to LOW to adjust the flame.
- Turn the control knob to the OFF position.
- To set the time of day press the clock button, adjust the clock by press the time UP and DOWN buttons.
- Press the BAKE button.
- Adjust the temperature to 375°F using the UP and DOWN TEMP buttons.
- The display should show BAKE, and the preheating temperature.
- Press the OFF button to stop the oven preheating process.
- If either the cook top or oven does not operate properly, do not attempt to repair the appliance yourself. American Range Corporation is not responsible for service required to correct a faulty installation.

INSTALLATION CHECKLIST

This checklist has been developed to assure proper installation of your oven.

To validate warranty, you must mail, e-mail or fax this form and a copy of your receipt to:

AMERICAN RANGE CUSTOMER SERVICE, 13592 DESMOND STREET, PACOIMA, CA 91331

service@americanrange.com

818.897.8839 FAX

Street: _____

Purchase Date: _____

City, State, Zip Code: _____

Installation Date: _____

E-mail: _____

Installer's Name: _____

Telephone: _____

Company: _____

Dealer: _____

Telephone: _____

CHECK ALL THAT APPLY

Appearance and Aesthetics

- Exterior
- Top section
- Oven interior

Electrical Connection

- Correct voltage
- Grounded outlet
- Polarized outlet
- No GFCI

Installation

- Read User Manual
- Review Safety Instructions
- Proximity to cabinets
- Backguard in place
- Level
- Ventilation system

Gas Connection

- Verify fuel: Natural -or- LP
- Gas shut-off present and accessible
- Gas Supply line properly sized
- Gas Supply pressure checked
- Operating pressure checked
- All connections checked for leaks

Ignition

- Top Burners
- Griddle
- Char Broiler
- Oven Burner
- Infrared Broiler

Flame Adjustment

- Top Burners
- Griddle
- Char Broiler
- Oven Burner
- Infrared Broiler

Air/Gas Mixture

- Top Burners
- Griddle
- Char Broiler
- Oven Burner
- Infrared Broiler

Valve Operation

- Top Burners
- Griddle
- Char Broiler
- Oven Burner
- Infrared Broiler

Controls

- Burner Knobs
- Thermostats
- Char Broiler
- Convection Oven Fan & Switch
- Oven Light Switch

Oven Door

- Alignment
- Door Seal
- Hinges

Customer Copy

PERFORMANCE CHECKLIST

A qualified installer should carry out the following performance checks referring to the User Manual as necessary:

- Check operation of oven setting Bake at 350°.
- Check operation of Broil function.
- Check operation of all top burners at high and low flame.
- Check operation of oven light using front panel control switch.
- Check operation of the convection fan using front panel control switch.
- Check operation of all indicator lights on control panel.

RANGE START-UP PROCEDURE

Before cooking in your oven for the first time remove oven racks and wash them with hot soapy water. Thoroughly rise, dry and replace them in the oven.

During initial start-up of the oven, after all performance checks and adjustments have been made, the oven should be allowed to burn off any oils or solvents left from the manufacturing process. In any case, these materials are safe for the environment – but it is best they not contribute to the taste or odor of your first oven cooking experience.

OVEN BURN-OFF PROCEDURE

- Turn on the kitchen ventilating hood.
- Light the oven according to the instructions in the manual.
- Set the oven thermostat temperature to 350°F.
- Let the oven run for one hour.
- Turn on the convection fan.
- Set the oven thermostat to 450°F.
- Leave the oven operational for an additional hour.
- Shut off the oven by turning the thermostat to the OFF position.

BROILER BURN-OFF PROCEDURE

- Turn on the kitchen ventilating hood.
- Light the broil burner according to the instructions in the manual.
- Operate the broiler for ten minutes.
- Open the door briefly – about ten seconds.
- Operate the broiler for an additional ten minutes.
- Shut off the broiler by turning the thermostat to the OFF position.

During the oven or broiler burn-off process, some strong odors or minor smoke may be experienced as remaining oils or solvents on internal parts are oxidized. This is the primary reason for the burn-off process and should dissipate by the completion of the time period.

OPERATING INSTRUCTIONS

BEFORE USING THE NEW COOK TOP

- Before using the cook top for the first time, wash the outside area with soap and water to remove any shipping & factory residue.
- The burner grates are designed in sections and are easy to remove and clean. They are made of cast iron with a porcelain coating and will remain hot after the burner is turned off creating a residual heat for continued cooking. Use caution when handling.
- Your new professional Range is equipped with burners that are similar to those used in restaurants. The burner heads are large and designed to ensure even heat distribution for better cooking. They must be in place and properly seated before lighting.
- The Range must not be operated without the burner heads.
- There are no continuously burning pilot lights. An electronic spark ignition system is used to light the burner. If the flame should go out from a boil-over or a strong draft, the burner will automatically re-ignite.

OPERATION OF THE BURNERS

1. Press in on the knob that corresponds to the burner that you would like to light. Use the front panel graphic to confirm your selection until you become familiar with the range. Turn the knob counter-clockwise to the "American Flame" icon located on the knob – this is the light position of the burner valve.
2. The igniter for all the surface burners will begin sparking – however, gas will flow to only the selected burner.
3. After the burner lights, the igniter clicking will stop – indicating that the flame sensing and re-ignition system is active on the selected burner.
4. Rotate the knob to any flame setting that you desire between MAX and SIMMER. The blue panel light will remain lit until the valve is returned to the OFF position.

The surface burners are rated at different power levels:

BURNER TYPE	SMALL	MEDIUM	LARGE
Open Burners	12,000 BTU/hr.	18,000 BTU/hr.	25,000 BTU/hr.
Sealed Burners	9,000 BTU/hr.	13,000 BTU/hr.	17,000 BTU/hr.

When you are using the surface burners, select the burner power and location depending on the heating or cooking function you would like to perform.

A normal flame is blue in color and steady. Foreign materials in the kitchen air or the gas line, especially in new construction installations, may cause some orange color bursts during initial operation. This will disappear with continued use. Small yellow tips on the ends of flames are normal when using LP gas.

If the flames look odd, (too small, too large, lazy or drifting, uneven around the burner circle, etc.), check to see that the burner head is seated correctly on the burner base. Do this when the burner is cold by gently rocking the burner head or rotating the head from side to side. If it is correctly seated, it will nest in detents, in the case of the sealed burners, or on the corresponding pin/hole for open burners. If this does not correct the problem, turn to the Troubleshooting section of this manual.

AUTO RE-IGNITION

The surface burners are equipped with a special ignition and re-ignition system that senses the presence of flame and re-ignites the burner should the flame disappear while gas is still flowing to the burner.

Strong drafts, spills and general grime influence the operation of the automatic re-ignition system – a clean system will generally function better than a dirty system. Periodically, remove any materials or grime that might build up on the high voltage spark electrode – using a toothbrush or other non-metallic cleaning utensil.

COOKWARE RECOMMENDATIONS

To avoid the risk of serious injury, damage to the range or cookware, please observe the following guidelines.

Bakeware, such as large casserole pans, cookie sheets, etc., should never be used on the cook top.

Placement of large stock pots should be staggered when used on the cook top.

Select the base diameter of the pot to match the diameter of the flame. The diameter of the flame and the diameter of the pan bottom should match or be slightly smaller. Too large or too small pots on a burner will compromise cooking performance.

Do not place food packaged or wrapped in aluminum foil directly on the burner grate above the burner. Aluminum foil can melt during cooking.

Be careful to not let plastic, paper or cloth come in contact with a hot burner grate. These materials can catch fire or melt.

Never let a pan boil dry – and if it occurs remember it can be extremely hot – and very dangerous. If this should occur, turn off the burner immediately. Wait a while, until the pot cools down enough to handle – this could be several minutes, but could save you from burns or other serious injury.

The pan bottom should be flat, the heavier the better – and well balanced on the cook top grate – sitting flat without rocking – preferably with tight fitting lids. Try not to slide the pot across the grates – while it is very handy to do so – you may end up scratching the pot or the grate.

Always be careful when using high flames, as in wok cooking, as they may contact flammable materials or make the handles of the wok very hot. Use the wok ring (optional) to stabilize the wok.

SUGGESTED BURNER SETTINGS	
HEAT SETTINGS	USE
Simmer	Melting small quantities of butter, simmer grains, rice, oatmeal
Low	Poaching eggs, fish, poultry
Low - Medium	Fry eggs, heat milk, cream sauces
Medium	Puddings, custards, gravies
Medium High	Sauté vegetables, braise meats, soups and stews, deep fat frying, boiling water and pasta, blanching vegetables, searing meats
High	Large quantity of water to boil, large quantity frying and cooking

APPLIANCE OPERATION

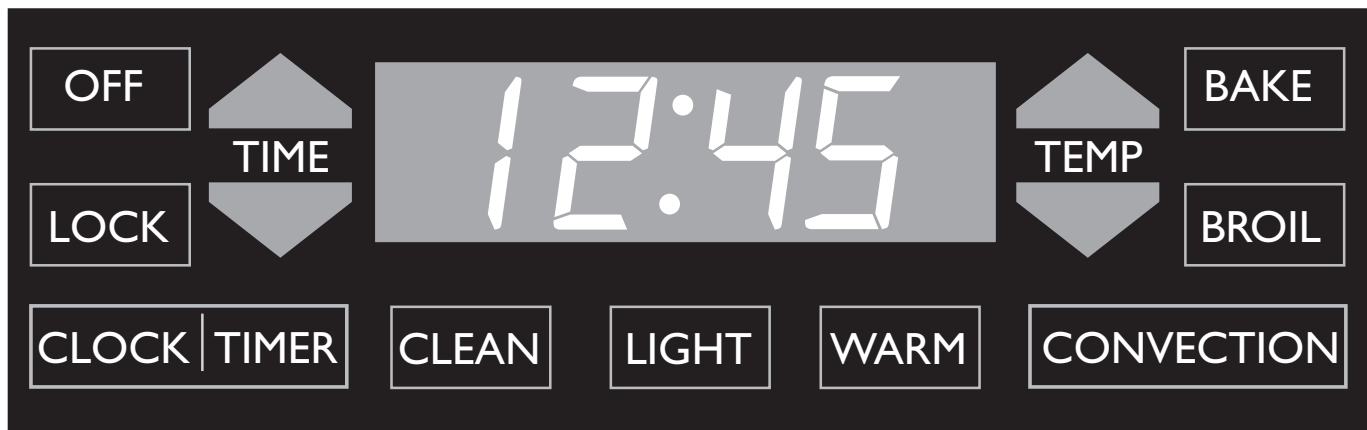

CONTROL PANEL KEYS

- CLOCK** Use this key to set the clock.
- OFF** Use this key to turn off the oven.
- TIMER** Use this key to time an event. You can use the timer without oven on.
- LOCK** Pressing this key for six seconds will lock or unlock the control panel.
- LIGHT** Use this key to turn on or off the oven lights.

Selects the type of cooking you want to perform by pressing one of the cooking mode keys.

COOKING MODES

- CLEAN** Activates the oven self-cleaning feature.
- CONVECTION BAKE** This mode is for single and double rack baking.
- BAKE** Uses only a heat source from below the food.
- BROIL** Uses a top heat source.
- WARM** Is used to warm food.

OVENS 101

The oven is an electrically heated, temperature controlled cooking cavity which is highly insulated to keep the kitchen cool and the food hot. The oven contains two burners - the Bake burner positioned below the oven floor and the Broil burner located in the ceiling of the oven. Bake and Broil are very different cooking operations and the burners are designed to deliver energy in a way appropriate to the task.

There are two types of baking - called Standard Bake (or conventional) and Convection Bake. Standard or conventional baking make best use of Grandma's cookie, cake or pie recipes – like Bake at 350°F for forty-five minutes – to get the job done. These recipes are tried and true – conventional or standard bake will deliver wonderful performance every time you cook.

When you convection cook (using a fan to circulate the high temperature air inside the oven) you can lower the thermostat about 25° and reduce the cook time by about 25% - and achieve fine cooking results just like Grandma's – taking less time and using less energy. Use the same recommended temperatures for meats and poultry dishes – but keep watch of the time. Convection cooking technology was first developed in Europe and has been used for many years – recently taking hold in US residential kitchens and cookbooks.

In convection cooking, not only is the cook time faster; but also, the oven temperature is more even, top to bottom and side to side – so cookies on several racks will have the same brown color and texture. Food does not need to be rotated to get uniform color. However, to best take advantage of convection, use low, shallow bakeware so that moving air can get over the sides and up to the food surface. Foods in covered dishes (like casseroles or pot roasts) do not benefit from convection cooking.

To get started, remove all plastic wrappers used to protect the finish of the Stainless Steel surfaces. If you do not, the wrapper may get stuck on the Stainless Steel when the oven is hot – making removal later very difficult.

Although care is taken at the factory to remove processing oils, consider a final wipe down using a soft cloth and hot, soapy water, well rinsed and dried from the surface.

CONTROL PANEL

The Dual Fuel Range control panel is your portal into a new dimension of cooking. A few presses of the keypad program the range to Bake, Broil, Convection Bake, Warm food, Self-Clean the oven or set the time of day clock or kitchen timer. The following is a "cook's tour" of the brains behind your dual fuel range.

To stop any heating process, like bake or broil or self-clean, press the OFF key.

Holding the LOCK key for several seconds locks the control panel for cleaning - or keeps inquisitive fingers of children from activating the appliance.

Press CLOCK, then use the TIME up or TIME down pyramids to roll the value shown in the display to the desired setting. If the display changes too quickly, simply let go of the button and start again – the rolling gets faster and faster the longer you hold the key pressed.

An on-board kitchen timer can be programmed using the TIME up or TIME down pyramids as well – press TIMER, then enter the desired setting.

To program SELF-CLEANING, press the CLEAN key, and enter a time period in hours. The oven will automatically lock, heat the oven cell to a high temperature, hold it hot for a period of time, and then cool down and unlock.

Press the LIGHT key to turn on the oven light – press it again to turn it OFF.

Use the WARM key to hold the oven at a temperature between 80F and 200F. The TEMP pyramids increase or decrease the temperature setting shown in the display. When you are done programming, wait three seconds for your input to be accepted. After that, the controller goes to work.

For standard baking recipes, press the BAKE key, using the TEMP pyramids to enter the recipe temperature. Wait three seconds for the input to be accepted. Preheat icons will illuminate on the display; when the oven has reached the desired temperature an audio alert tone will sound.

Press the BROIL key and use the TEMP pyramids to select HI or a regulating temperature. For special recipes, the regulating temperature will control just how much searing will occur during BROIL.

Convection cooking is performed using the CONVECTION key. Simply press CONVECTION, set a temperature using the TEMP pyramids and wait three seconds. After preheating, the controller operates the convection ring and other heat sources to create the requested temperature.

APPLIANCE OPERATION

TO ACTIVATE SABBATH MODE

1. Press the BAKE key and select an oven operating temperature using the TEMP UP or TEMP DOWN keys. The red colored "BAKE" icon will flash for a few seconds while the electronic control "accepts" the newly programmed oven operating temperature.
2. Now, press and hold the BAKE key for three (3) seconds. The temperature display portion of the control will show - - - o.
3. Finally, press the TEMP UP or DOWN key to enter the Sabbath operating mode – shown in the oven control display as SAB.
4. To cancel the Sabbath operating mode, depress the OFF key.
5. Once you become familiar with the programming of the control, you might look at selecting Sabbath mode BAKE as entering standard baking mode and then, re-entering standard baking mode again!
6. As always, if you need to start over, press the OFF button – no harm done!

GRILL OPERATION

To turn on the grill, make sure there is nothing on the grilling rack, push in and turn the control counter now clockwise to the HIGH position. The power ON indicator light will glow indicating the grill valve is on. The grill is equipped with a flame-sensing ignition system – that automatically detects the presence of flame on the grill burner – and relights it in the event it should go out.

After cooking, allow the module to cool completely and remove the drip tray slowly, discarding grease and other food particles. The grill grate may be removed - exposing the radiants - which may be lifted out and placed in the dishwasher along with the drip tray for cleaning. The grate is porcelain coated and may be washed with hot soapy water and a soft brush.

BEST COOKING RESULTS WHEN USING YOUR GRILL

The intense radiant heat from the grill vaporizes the surface of your food, locking in flavor:

- Add any barbecue sauces during the last few minutes of cooking, long enough to caramelize the sauce.
- For best results, turn food with tongs or a flat spatula to avoid piercing meat or poultry.
- Turn meat once when juices rise to the surface. Turning meat more than once results in the loss of meat juices.
- Never squeeze juices out of meat.
- Before cooking steaks or chops, trim most of the outside fat to prevent excessive flare-ups. Slash into the edges of steaks or chops to keep meat flat on the grill.

GRILL CHART		
FOOD ITEM	INTERNAL TEMPERATURE	TIME
Hamburgers 1/2" to 3/4"	160°	8 to 10 minutes
Steaks 1" to 1-1/2"	Rare 140°	10 to 20 minutes
Steaks 1" to 1-1/2"	Medium 160°	12 to 25 minutes
Pork chops 3/4" to 1"	145° & 3 minutes rest time	15 to 25 minutes
Lamb chops	160°	12 to 15 minutes
Poultry pieces	170°	25 to 35 minutes
Fish 1" thick	145° Minimum	8 to 10 minutes

Allow grill to cool completely before cleaning. Remove the grates, grease collector and Stainless Steel Radiant and place in hot soapy water. Clean the grill with hot soapy water and a soft grill brush.

Do not apply water or cleaner directly on the infrared burner.

GRIDDLE OPERATION

The built-in griddle is made of polished steel to provide a smooth cooking surface. A griddle drip pan is included.

Always pre-heat the griddle on the low setting, at least ten minutes before cooking. The griddle burner is equipped with a hot surface igniter and gas safety valve system.

TO START COOKING:

- Push knob in and turn the knob clockwise to the MAX position. Preheat griddle for two to three minutes and turn knob to a medium or low cook setting.
- The blue indicator light comes on and stays on until the desired setting is reached and then turns off and on with the heating cycle.
- For best results, add a small amount of butter, oil, or a cooking spray to the griddle surface. Fatty meats like bacon and sausage do not need extra fat.

SEASON THE GRIDDLE:

1. The griddle has a factory applied coating that must be washed off prior to use. (See Cleaning the Griddle)
2. Pour 1 tablespoon of vegetable oil (not corn or olive oil) and rub on the entire surface of the griddle using a rough towel.
3. Push the griddle control knob in and turn to a medium setting (350°F).
4. Heat until griddle begins to smoke. Turn off griddle and allow it to cool.
5. Returning to step 2, repeat the process.

When you are done "griddling" and while the griddle surface is still warm, remove any left-on food particles. Allow the griddle to cool and scrape off any excess grease from the surface with a flexible nylon spatula. Pull the spatula forward toward the front and push any material into the front grease receiver.

To clean the griddle, moisten a soft scrub cloth, adding a drop of mild degreaser dish soap to create a soapy lather - and wipe the griddle from left to right. Clean in rows from the top to the bottom, taking time to wash the entire griddle surface, including the sides. When you are done, rinse away all the soap from the cloth and wipe any suds from the griddle surface. Remove all remaining moisture from the griddle with the second, clean soft cloth. Wipe the area in rows again as well as the sides and front. You may have to repeat action to ensure the griddle plate is dry and sparkling.

CLEANING THE GRIDDLE:

- The griddle is not to be removed for cleaning.
- Using a flat plastic spatula gently remove burned on food.
- Clean the griddle thoroughly with hot soapy water and a rough towel.
- The griddle drip pan and trough should be cleaned after each use with hot soapy water and a sponge.
- It is normal for the griddle to darken with age and use, similar to commercial cooking equipment.

GRIDDLE CHART		
FOOD ITEM	TEMP. SETTING	HEAT SETTING
Eggs	225°F to 250°F	Low
Bacon, Ham, Hot dogs	300°F to 325°F	Medium - Low
Sausage, Grilled cheese sandwiches	325°F to 350°F	Medium
Pancakes, French toast	350°F to 375°F	Medium
Hash brown potatoes, Grilled onions	400°F to 425°F	Medium - High

The temperature settings are meant as a guide. You may need to vary the settings according to taste.

MAINTENANCE

The control panel automatically locks the oven door during self-cleaning. The latch prevents the door from being opened since the high interior oven temperatures can easily cause injury. After the Self-Clean cycle is complete reinstall the oven racks. You may also notice powder ash in the bottom of the oven after Self-Cleaning. This is normal. Use a damp cloth or sponge to wipe up the residue after the oven cools down.



CAUTION

Do not use abrasive cleaners or scrubbers on the control. They will permanently damage the finish.

CLEANING STAINLESS STEEL SURFACES

Clean with a soft dampened sponge with a mild solution of detergent and warm water. Rinse and dry completely with a soft lint-free cloth.

CAUTION

Always wipe Stainless Steel surfaces with the grain. To prevent scratching, do not use abrasive cleaners or scrubbers on Stainless Steel surfaces.

CLEANING GLASS (INTERIOR AND EXTERIOR)

Use a mild glass cleaner (i.e.; Simple Green) to remove finger prints on glass surfaces. You can also clean glass surfaces with Cook top Cleaning Cream. Use according to manufacturer's directions.

CARE AND CLEANING

It is always easier to clean as you go – and while some evenings you'd rather sit down with a good book instead of a Scrubbie, keeping your range cook top and oven in a ready to go state for the next meal makes everything a little more tolerable.

When cleaning the range:

- ✓ Use the mildest procedure that will do the job efficiently and effectively – and since some cleaners are harsher than others, it is best to try them on a small, inconspicuous area first.
- ✓ Use only clean, soft cloths, sponges, paper towels, plastic brushes, non-metal soap pads for cleaning and scouring.
- ✓ When cleaning the oven door, control panel, top curved section (called the bull nose) or the flat top area – always pretend it is made of wood – and rub the finish in the direction of the grain. This is the most effective cleaning direction, to prevent marring the surface.
- ✓ Any part of this appliance can be cleaned with hot, sudsy water. When rinsing is required, rinse thoroughly.
- ✓ Always wipe dry immediately to reduce the appearance of water marks.

TO CLEAN THE COOK TOP

The cook top is brushed Stainless Steel with polished aluminum burner heads. The burner caps are steel coated porcelain.

- ✓ Do not use abrasives on Stainless Steel. Use towels, sponges or soft plastic scrubbers. **RUB ONLY WITH THE "GRAIN".**
- ✓ Do not use steel wool pads or green rough Scrubee's.
- ✓ Wash all cooking surfaces with hot water and dish detergent such as Simple Green, Ivory Liquid, or Joy.
- ✓ Rub stubborn spots with baking soda or liquid cleaner such as Windex All Surface Cleaner or 409.
- ✓ Grates and burner caps can be soaked in hot soapy water. Mild scouring cleaners can be used, such as Bon Ami or Cameo on grates and burner caps.

TO CLEAN THE OVEN

The oven cavity is porcelainized with steel rack guides and racks. The infrared broiler does not need to be cleaned. Any soil is burned off by the intense heat.

- ✓ Place a medium glass baking dish filled with two cups of ammonia. Close the door and allow the dish to sit overnight. This process softens the soil for easier removal.
- ✓ Wash the interior of the oven with soap and water. Make a paste with baking soda and water and using a sponge or nylon pad rub away stubborn stains.
- ✓ Use mild scrubbing compounds such as Bon Ami or Cameo if necessary.
- ✓ Do not use steel wool pads or abrasive sponges or scrubbers.
- ✓ If necessary, spray oven cleaner can be used. **DO NOT SPRAY OVEN CLEANER INTO THE CONVECTION FANS OR UP ONTO THE INFRARED BROILER.**
- ✓ When spray oven cleaners are used, follow using a 1/4 cup vinegar mixed with one quart of water to rinse the oven.
- ✓ Do not use scouring powders on the glass window; oven spray may be used on the window. Rinse with vinegar and water solution.

CLEANING RECOMMENDATIONS		
PART / MATERIAL	CLEANING SUGGESTIONS	BEING CAREFUL
Main Top/ Porcelain Enamel	Soft Scrub may be used here. With a cool or slightly warm surface, use a damp sponge or cloth as recommended by the manufacturer.	Since the surface is glass (it can be scratched by certain materials) try to rub gently in small circles to allow time and chemical reactions to take place.
Sealed Burners	Caps and burner heads can be removed for cleaning using hot sudsy water. A stiff nylon bristle tooth brush can be used to clean burner port openings.	Remember to dry out the ports (try to blow air through them if you like). Water clogged ports burn with erratic flames and could be dangerous.
Open Burners	The cast iron burner heads are heavy and porcelain coated. If they are dirty, remove any large debris and gently scrub under hot, soapy water.	Like the sealed burners, remember to dry out the ports (try to blow air through them if you like). Water clogged ports burn with erratic flames and could be dangerous.
Control Knobs/ Power Paint	Use dry hands to pull off the knobs; hot sudsy water works best here...	...with a sponge to avoid scratching
Chrome Knob Bezels	Hot soapy water works well here, with a sponge or soft cloth.	As with any round feature that meets the stainless steel grain, be careful to clean the bezels in a circular motion – and not contact the S/Steel control panel.
Exterior Finish Island Trim	Use hot soapy water, Fantastic, Formula 409, rinse and dry immediately. For hard water spots, try household vinegar or CLR. If there is any heat discoloration, consider using Zud, Wright's All Purpose Polish or Blue Away.	Rub lightly in the direction of the grain of the Stainless Steel. Salt (sodium chloride), chlorine or chlorine compounds in some cleaners are corrosive to Stainless Steel.
Grates/Porcelain Enamel on Cast Iron	Hot water & detergent with scrubbie, or soap filled steel wool pad for really tough stains will work.	Remove sugar or acid based spills, they tend to attack the enamel. Remember the grates are heavy, use care when lifting and replacing.
Griddle	Moisten a soft scrub cloth, adding a drop of mild dish soap to create a soapy lather - and wipe the griddle from left to right.	Use plastic spatulas and spoons when working the griddle. See more tips in the discussion on griddle operation on page 21.

TROUBLESHOOTING GUIDE

MEDALLION DUAL FUEL RANGES		
PROBLEM	POSSIBLE CAUSE	WHAT TO DO
Nothing works.	• Range not connected to electrical power.	• Have electrician connect range to properly wire electrical connection.
	• Power to range is off.	• Turn power on at the junction box. • Check for tripped circuit breaker or blown fuse.
	• Control panel locked.	• Press and hold LOCK key for six seconds • to reactivate control panel.
	• Power outage.	• Contact power company.
Oven will not heat.	• No electrical power to the range • Gas service is turned off • Gas supply has been interrupted • Look for red glow of hot surface igniter • Oven setting not correct.	• Press BAKE and program a new temperature using • TEMP UP or TEMP DOWN.
Time on display not correct.	• Time of day not set.	• Set time.
	• Power failure or power was turned off.	• Reset time.
Time flashes on display.	• Power failure or power was turned off.	• Reset time.
Oven does not self-clean.	• Door not shut correctly.	• Check for obstructions.
Oven light does not work	• Light switch is in the off position • Light is burned out	• Try switching the light on • Locate and test a new replacement light, unscrew glass lens, remove bad light, replace
Broiler will not light	• No electrical power to the range • Gas service is turned off • Look for red glow of hot surface igniter	• Check circuit breakers in house • Try to light a surface burner • If no glow, call for service
Burner lights, but clicking won't stop	• Mis-wired high voltage connections	• See that the burners are correctly matched to the high voltage connections
Convection fan does not turn	• Switch the fan on • Unit in Broil mode • Bad fan	• Use the control panel switch • Turn thermostat to Bake temperatures • Call for service
Igniters keep clicking	• Reverse polarity of the electrical supply line • Poor electrical ground	• Check the polarity with hand held tester • Be sure range power cord has three prongs and plugs directly (no adapter) into the power receptacle
Condensation on the oven window	• Cold appliance	• During cold weather, it is normal for some condensation to appear of the window, it will disappear in about ten minutes.
Foods over-cook	• Incorrect temperature or cooking time • Defective thermostat	• Reduce cooking time or temperature • Watch that thermostat indicator light cycles on and off every five or ten minutes at temperature

WARRANTY REQUIREMENT

For reliable operation and for your own safety, this professional cooking equipment must be installed by a certified/licensed contractor.

Failure to comply will void any written or implied warranty.

Should the equipment require service during the standard warranty period, the receipt proving certified installation must be made available to American Range for verification.

If installation was not performed by a certified/licensed contractor be prepared to submit a major credit card for payment for proper installation prior to service.



13592 Desmond Street, Pacoima, CA 91331
818.897.0808 tel 888.753.9898 toll free
818.897.1670 fax
www.americanrange.com