



INSTALLATION AND OPERATING INSTRUCTIONS

Counter Top Warmers

Model Numbers: W-9iSP, W-9iSP2, W-9iSP3

**INTENDED FOR OTHER THAN HOUSEHOLD USE
RETAIN THIS MANUAL FOR FUTURE REFERENCE
UNIT MUST BE KEPT CLEAR OF COMBUSTIBLES AT ALL TIMES**

This equipment has been engineered to provide you with year-round dependable service when used according to the instructions in this manual and standard commercial kitchen practices.

IMPORTANT FOR FUTURE REFERENCE

Please complete this information and retain this manual for the life of the equipment. For Warranty Service and/or Parts, this information is required.

Model Number

Serial Number

Date Purchased



WARNING: For your safety do not store or use gasoline or other flammable vapors or liquids in the vicinity of this or any other appliance. Keep the area free and clear of combustibles. (See ANZI Z83.14B, 1991)



WARNING: Improper installation, operation, service or maintenance can cause property damage, injury or death. Read and understand these instructions thoroughly before positioning, installing, maintaining or servicing this equipment.



P/N 59161 – 04/13

APW WYOTT Foodservice Equipment Company

P.O. Box 1829
Cheyenne, WY 82003

+1 (307) 634-5801 Phone
+1(307) 637-8071 Fax

+1 (800) 752-0863 Toll Free
www.apwwyott.com

APW Wyott takes pride in the design and quality of our products. When used as intended and with proper care and maintenance, you will experience years of reliable operation from this equipment. To ensure best results, it is important that you read and follow the instructions in this manual carefully.









Installation and start-up should be performed by a qualified installer who thoroughly read, understands and follows these instruction.

If you have questions concerning the installation, operation, maintenance or service of this product, contact APW Wyott Foodservice Equipment Company's "Technical Service Department".

















SAFETY PRECAUTIONS

Before installing and operating this equipment be sure everyone involved in its operation are fully trained and are aware of all precautions. Accidents and problems can result by a failure to follow fundamental rules and precautions.

The following words and symbols, found in this manual, alert you to hazards to the operator, service personnel or the equipment. The words are defined as follows:

	DANGER: This symbol warns of imminent hazard which will result in serious injury or death.	
	WARNING: This symbol refers to a potential hazard or unsafe practice, which could result in serious injury or death.	
	CAUTION: This symbol refers to a potential hazard or unsafe practice, which may result in minor or moderate injury or product or property damage.	
	NOTICE: This symbol refers to information that needs special attention or must be fully understood even though not dangerous.	

1. IMPORTANT SAFETY INSTRUCTIONS

	IMPORTANT: Read the following important safety instructions to avoid personal injury or death, and to avoid damage to the equipment or property.	
	WARNING: Plug unit into a properly grounded electrical outlet of the correct voltage, size and plug configuration. If the plug and receptacle do not match, contact a qualified electrician to determine the proper voltage and size and install the proper electrical outlet.	
	WARNING: Unit is not waterproof. DO NOT submerge in water. Do not operate if it has been submerged in water.	
	WARNING: To avoid any injury, turn the power switch off at the fuse disconnect switch/circuit breaker or unplug the unit from the power source and allow to cool completely before performing any maintenance or cleaning.	
	WARNING: To avoid electrical shock, always unplug the unit before performing cleaning or maintenance.	
	WARNING: Do not place food product directly onto hardcoat surface. Food product must be wrapped, boxed or on a food pan.	
	WARNING: For safe and proper operation, the unit must be located a reasonable distance from combustible walls and materials. If safe distances are not maintained, discoloration or combustion could occur.	
	WARNING: To avoid electrical shock or personal injury, do not steam clean or use excessive water on the unit.	



WARNING: If service is required on this unit, contact your authorized APW Wyott Service Agent, or contact the APW Wyott Service Department directly at (214) 421-7366 or (800) 527-2100; fax (214) 565-0976.



WARNING: This product has no "user" serviceable parts. To avoid damage to the unit or injury to personnel, use only Authorized APW Wyott Service Agents and genuine APW Wyott Parts when service is required..



WARNING: Genuine APW Wyott Replacement Parts are specified to operate safely in the environments in which they are used. Some aftermarket or generic replacement parts do not have the characteristics that will allow them to operate safely in APW Wyott equipment. It is essential to use APW Wyott Replacement Parts when repairing APW Wyott equipment. Failure to use APW Wyott Replacement Parts may subject operators of the equipment to hazardous electrical voltage, resulting in electrical shock or burn.



CAUTION: Some exterior surfaces on the unit will get hot. Use caution when touching these areas to avoid injury.



CAUTION: Locate the unit at the proper counter height, in an area that is convenient for use. The location should be level to prevent the unit or it's contents from accidentally falling, and strong enough to support the weight of the unit and food.



CAUTION: The National Sanitation Foundation (NSF) requires that units over 36" (91 cm) in length or weighing more than 80 lbs. (36 kg) to be either sealed or raised on the installation surface. If this unit cannot be sealed at the point of use, 4" (10 cm) legs are included to allow for proper cleaning access below unit.



CAUTION: Use only non-abrasive cleaners. Abrasive cleaners could scratch the finish of your unit, marring it's appearance and making it susceptible to dirt accumulation.



CAUTION: Only soft cleaning cloths should be used to clean breath protector(s). Breath protector(s) are made of shatterproof polycarbonate and will scratch if proper care is not taken.



2. GENERAL INFORMATION

General Installation

1. Always clean equipment thoroughly before first use. (See general cleaning instructions.)
2. Check rating label for your model designation & electrical rating.
3. Locate equipment on level counter and plug into a grounded outlet so that the plug is accessible. (See individual description for electrical loads.) On units bearing the CE marking the appliance must be connected by an earthing cable to all other units in the complete installation and hence to an independent earth connection.

General Operating Instructions

1. All foodservice equipment should be operated by trained personnel.
2. Do not allow your customers to come in contact with any surface labeled "CAUTION HOT."
3. Where applicable: Never pour cold water into dry heated units.
4. Where applicable, do not cook, warm or hold food directly in liner pans (well pans). Always use steam table pans/insets, etc.
5. Never hold food below 140°F

General Cleaning Instructions

1. NEVER clean any electrical unit by immersing it in water. Unplug unit before surface cleaning.
2. Always clean equipment thoroughly before first use. Clean unit daily. Except where noted on charts: Use warm, soapy water. Mild cleansers & PLASTIC scouring pads may be used to remove baked-on food & water scale.
3. Unplug all units before cleaning or servicing. All service should be performed by an APW Wyott authorized service agency.
4. Do not use chlorides or chloride-based products in this unit. Always clean equipment before first use. Clean unit daily. Use warm, soapy water. Rinse thoroughly to remove all residue. Chlorides, chloride-based products and improper cleaning may cause corrosion and pitting. Failure to comply with these instructions may void unit warranty.

3. ELECTRICAL SPECIFICATIONS:

W-9iS	– Single Well, Thermostatic Control	120 V	2.9 A	350W
W-9iS2	– Double Well, Thermostatic Control	120 V	5.8 A	700W
W-9iS3	– Triple Well, Thermostatic Control	120 V	8.8 A	1050W



CAUTION: Warmers can be operated wet or dry. If operating in dry condition Hi-Temp Pan Inserts (325°F min) must be used.



4. INSTALLATION & OPERATION

Installation:

1. Follow General Information on Page 3
2. Units are designed to be operated as a dry-well. Adding water to the well may alter performance settings.

Operation:

Thermostatic Controls

1. Follow General Information on Page 3.
2. Ensure dials are set to zero before plugging in unit; this is the “Off” position.
3. Plug in unit to properly rated outlet.
4. Place pans with lids into well for more efficient preheating.
5. For Preheat, turn knobs until indicator lights come on. Settings will need to be adjusted for each application, but turning the dials to 8-9 will be a good starting point to maintain product temperature at 150°.
6. Allow unit to preheat for 10-15 minutes.
7. Fill pans with pre-heated product (150°F).
8. Install Lids.

5. GENERAL TROUBLESHOOTING

ALWAYS ASK AND CHECK:

1. Is the unit connected to a live power source?
2. Check the circuit breaker.
3. Is power switch on and pilot light glowing?
4. Check the rating label. Are you operating unit on the proper voltage?

If the above checks out and you still have problems, call an APW Wyott authorized service agency.

EXPLODED VIEW

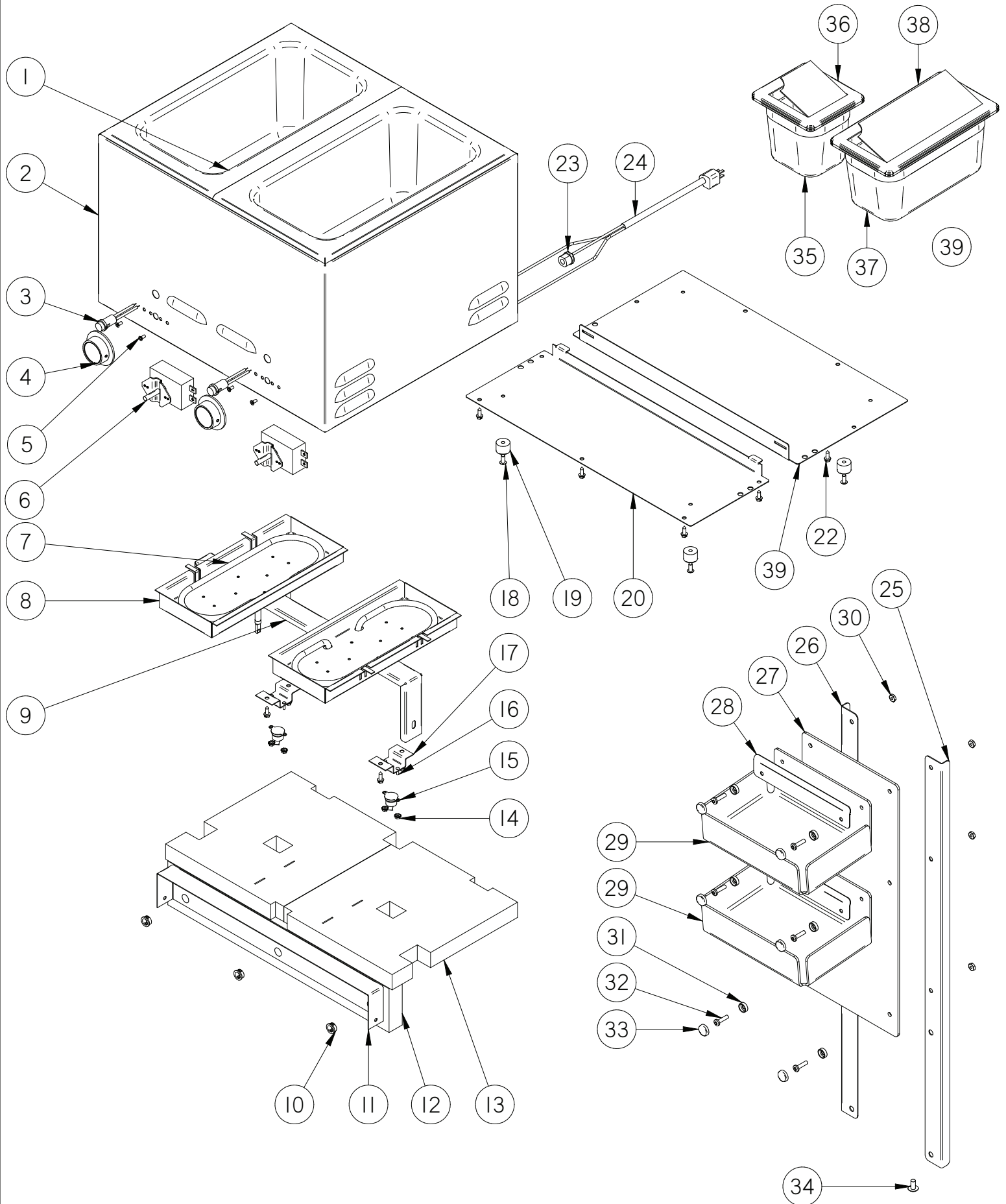

PARTS LIST

ITEM	DESCRIPTION	SINGLE WELL	DOUBLE WELL	TRIPLE WELL
1	WELDMENT, WELL PAN	59050	59056	59057
2	WRAPPER	59060	57022	59062
3	LIGHT PILOT	56530	- SAME -	- SAME -
4	KNOB, BLACK PLAIN (I TO IO)	56505	- SAME -	- SAME -
5	SCREW, COUNTERSINK, 6-32X5/16,Z,BLK	94000114	- SAME -	- SAME -
6	THERMOSTAT, MODEL K-396-12 M-83	60320	- SAME -	- SAME -
7	ELEMENT, 1/3 WARMER, 350W 120V	57028	- SAME -	- SAME -
8	REFLECTOR, ELEMENT	59072	- SAME -	- SAME -
9	HOLD DOWN, REFLECTORS	59376	59076	59276
10	BUSHING, .5 HEYCO 2058	89182	- SAME -	- SAME -
11	HEAT SHIELD	59382	59082	59282
12	INSULATION, DIVIDER	59128	59129	59130
13	INSULATION, RR BTM, I-WELL	59124	59125	59125 / 59126
14	NUT, 4-40 S/S KEPS EXT TOOTH LOCKWASHER	8100600	- SAME -	- SAME -
15	HIGH LIMIT, OPEN 450°F	69112	- SAME -	- SAME -
16	STUD, PEM #4-40 X 3/8	8206615	- SAME -	- SAME -
17	STANDOFF, HI LIMIT	59073	- SAME -	- SAME -
18	RIVET, POP 66D	89175	- SAME -	- SAME -
19	FOOT, RUBBER	55768	- SAME -	- SAME -
20	COVER, BOTTOM	59380	59083	59283
21	COVER, BOTTOM REAR	NA	59081	59281
22	SCREW, #8 X 1/2 HEX TAPIT SHT MTL TYPE AB	89073	- SAME -	- SAME -
23	BUSHING STRAIN RELIEF	89101	- SAME -	- SAME -
24	CORDSET I6GA, SJTO, NEMA 5-15P	55947	- SAME -	- SAME -
25	UPRIGHT, RIGHT	59090	- SAME -	- SAME -
26	UPRIGHT, LEFT	59091	- SAME -	- SAME -
27	SIGN HOLDER	59393	59093	59293
28	CROSS BRACE	59392	59092	59292
29	BOWL HOLDER	59394	59094	59294
30	NUT, JAM	89065	- SAME -	- SAME -
31	SNAP CAP, WASHER	89098	- SAME -	- SAME -
32	SCREW, 10-24 x 3/4	89030	- SAME -	- SAME -
33	SNAP CAP, COVER	89099	- SAME -	- SAME -
34	SCREW, 1/4-20 X 1/2 TR HD	8205500	- SAME -	- SAME -
35	INSERT, 1/6 PAN, HI-TEMP	2420800	- SAME -	- SAME -
36	LID, 1/6 PAN, HINGED	2420810	- SAME -	- SAME -
37	INSERT, 1/3 PAN, HI-TEMP	NA	2420900	- SAME -
38	LID, 1/3 PAN, HINGED	NA	2420910	- SAME -
39	LADLE, 4oz (not shown)	2421000	- SAME -	- SAME -

WIRING SCHEMATIC

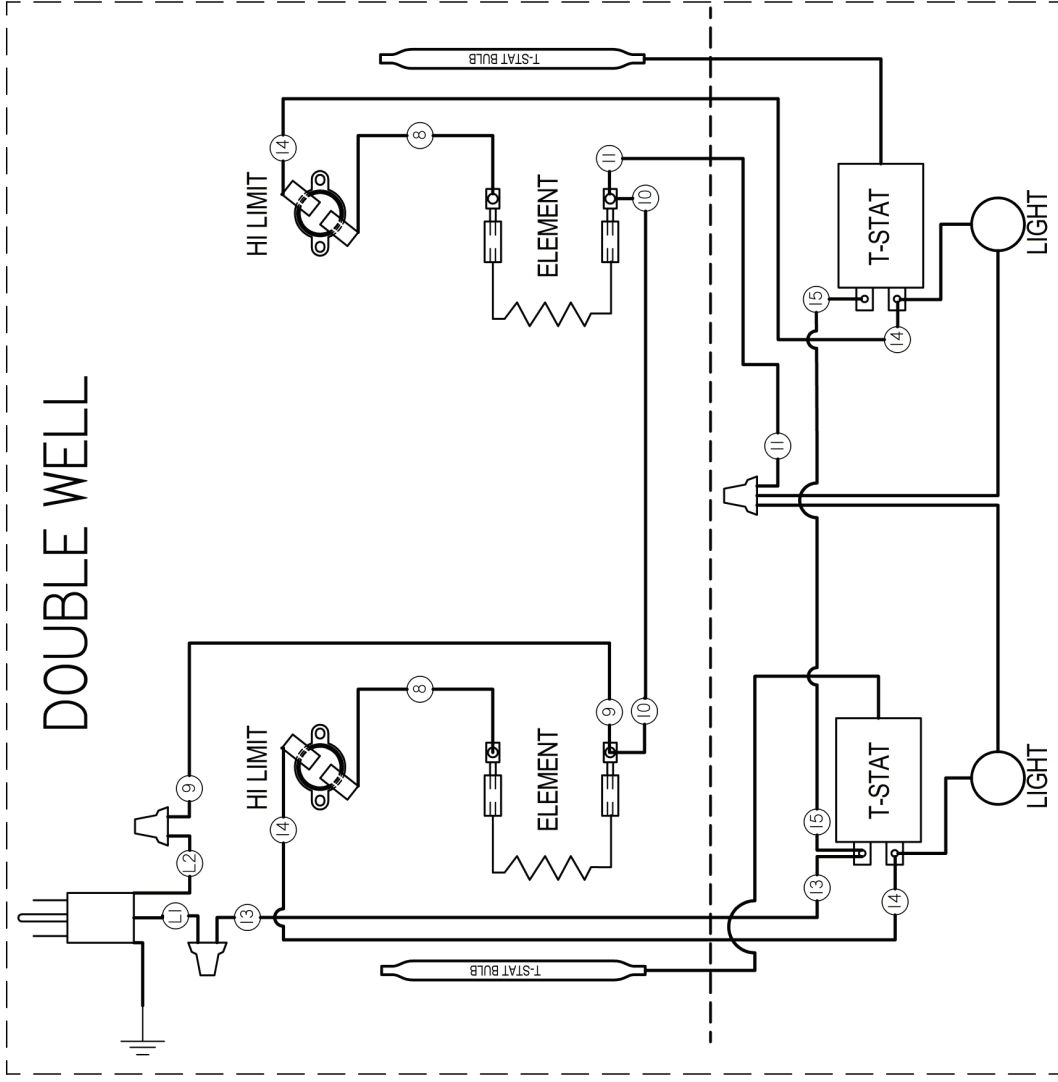
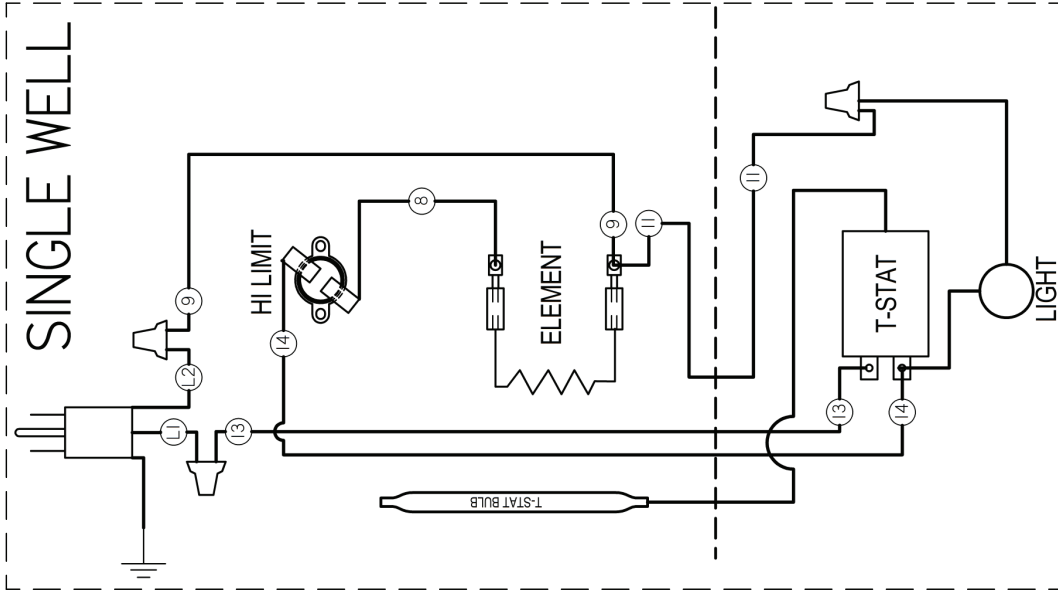

WIRING SCHEMATIC

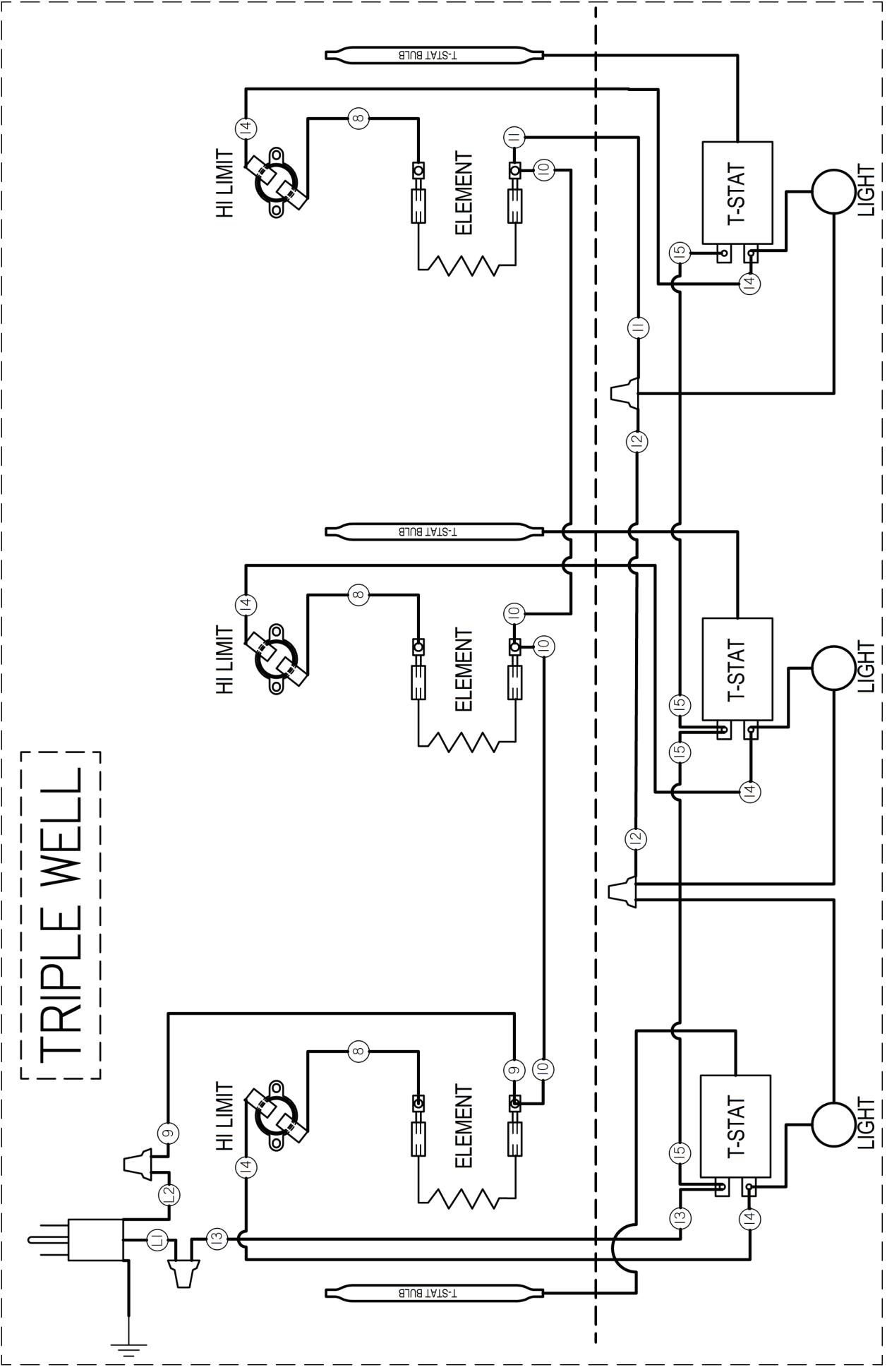

12. APW WYOTT EQUIPMENT LIMITED WARRANTY

APW Wyott Foodservice Equipment Company warrants its equipment against defects in materials and workmanship, subject to the following conditions:

This warranty applies to the original owner only and is not assignable.

Should any product fail to function in its intended manner under normal use within the limits defined in this warranty, at the option of APW Wyott such product will be repaired or replaced by APW Wyott or its Authorized Service Agency. APW Wyott will only be responsible for charges incurred or service performed by its Authorized Service Agencies. The use of other than APW Wyott Authorized Service Agencies will void this warranty and APW Wyott will not be responsible for such work or any charges associated with same. The closest APW Wyott Authorized Service Agent must be used.

This warranty covers products shipped into the 48 contiguous United States, Hawaii, metropolitan areas of Alaska and Canada. There will be no labor coverage for equipment located on any island not connected by roadway to the mainland.

Warranty coverage on products used outside the 48 contiguous United States, Hawaii, and metropolitan areas of Alaska and Canada may vary. Contact the international APW Wyott distributor, dealer, or service agency for details.

Time Period

One year for parts and one year for labor, effective from the date of purchase by the original owner. The Authorized Service Agency may, at their option, require proof of purchase. Parts replaced under this warranty are warranted for the un-expired portion of the original product warranty only.

Exceptions

***Gas/Electric Cookline:** Models GCB, GCRB, GF, GGM, GGT, CHP-H, EF, EG, EHP. Three (3) Year Warranty on all component parts, except switches and thermostats. (2 additional years on parts only. No labor on second or third year.)

***Broiler Briquettes, Rock Grates, Cooking Grates, Burner Shields, Fireboxes:** 90 Day Material Only. No Labor.

***Heat Strips:** Models FD, FDL, FDD, FDDL. Two (2) Year Warranty on element only. No labor second year.

***Glass Windows, Doors, Seals, Rubber Seals, Light Bulbs:** 90 Day Material Only. No Labor.

In all cases, parts covered by extended warranty will be shipped FOB the factory after the first year.

Portable Carry In Products

Equipment weighing over 70 pounds or permanently installed will be serviced on-site as per the terms of this warranty. Equipment weighing 70 pounds or under, and which is not permanently installed, i.e. with cord and plug, is considered portable and is subject to the following warranty handling limitations. If portable equipment fails to operate in its intended manner on the first day of connection, or use, at APW Wyott's option or its Authorized Service Agency, it will be serviced on site or replaced.

From day two through the conclusion of this warranty period, portable units must be taken to or sent prepaid to the APW Wyott Authorized Service Agency for in-warranty repairs. No mileage or travel charges are allowed on portable units after the first day of use. If the customer wants on-site service, they may receive same by paying the travel and mileage charges. Exceptions to this rule: (1) countertop warmers and cookers, which are covered under the Enhanced Warranty Program, and (2) toasters or rollergrills which have in store service.

Exclusions

The following conditions are not covered by warranty:

*Equipment failure relating to improper installation, improper utility connection or supply and problems due to ventilation.

*Equipment that has not been properly maintained, calibration of controls, adjustments, damage from improper cleaning and water damage to controls.

*Equipment that has not been used in an appropriate manner, or has been subject to misuse or misapplication, neglect, abuse, accident, alteration, negligence, damage during transit, delivery or installation, fire, flood, riot or act of god.

*Equipment that has the model number or serial number removed or altered.

If the equipment has been changed, altered, modified or repaired by other than an Authorized Service Agency during or after the warranty period, then the manufacturer shall not be liable for any damages to any person or to any property, which may result from the use of the equipment thereafter.

This warranty does not cover services performed at overtime or premium labor rates. Should service be required at times which normally involve overtime or premium labor rates, the owner shall be charged for the difference between normal service rates and such premium rates. APW Wyott does not assume any liability for extended delays in replacing or repairing any items beyond its control.

In all cases, the use of other than APW Wyott Authorized OEM Replacement Parts will void this warranty.

This equipment is intended for commercial use only. Warranty is void if equipment is installed in other than commercial application.

Water Quality Requirements

Water supply intended for a unit that has in excess of 3.0 grains of hardness per gallon (GPG) must be treated or softened before being used. Water containing over 3.0 GPG will decrease the efficiency and reduce the operation life of the unit.

Note: Product failure caused by liming or sediment buildup is not covered under warranty.

"THE FOREGOING WARRANTY IS IN LIEU OF ANY AND ALL OTHER WARRANTIES EXPRESSED OR IMPLIED INCLUDING ANY IMPLIED WARRANTY OF MERCHANTABILITY OR FITNESS FOR PARTICULAR PURPOSES AND CONSTITUTES THE ENTIRE LIABILITY OF APW WYOTT. IN NO EVENT DOES THE LIMITED WARRANTY EXTEND BEYOND THE TERMS STATED HEREIN."

9/05



Phone: (214) 421-7366
Fax: (214) 565-0976
Toll Free: (800) 527-2100
Website: www.apwwyott.com
E-mail: info@apwwyott.com

APW WYOTT
729 Third Avenue
Dallas, TX 75226