



DESIGNED SMART. BUILT SOLID.®

RADIANT CONVEYOR TOASTER

MODELS:
XTRM-1



OWNERS MANUAL

2M-93100174 REV B (01-23)



WARNING: California Residents Only. This product can expose you to chemicals including chromium which is known to the State of California to cause cancer and birth defects or other reproductive harm. For more information go to www.P65Warnings.ca.gov.



FOR YOUR SAFETY: Do not store or use gasoline or other flammable vapors and liquids in the vicinity of this or any other appliance.



WARNING: Improper installation, operation, service or maintenance can cause property damage, injury or death. Read and understand these instructions thoroughly before positioning, installing, maintaining or servicing this equipment.



Initial heating of appliance may generate smoke or fumes and must be done in a well ventilated area. Overexposure to smoke or fumes may cause nausea or dizziness.

APW Wyott® cooking equipment has been engineered to provide you with year-round dependable service when used according to the instructions in this manual and standard commercial kitchen practices.

This manual includes material related to installation, use, cleaning, and care. Exploded view[s], as well as any available parts list[s] and wiring diagram[s] pertaining to the unit[s] covered by this manual are also included.

This manual must be read and understood by all persons using or installing this appliance. Contact your APW Wyott dealer if you have any questions concerning installation, use, or maintenance of this equipment.

DO NOT DISCARD THIS MANUAL.

APW Wyott Food Service Equipment Company
265 Hobson St. • Smithville, TN 37166
(800) 527-2100 • apwwyott.com

SERVICE INFORMATION

IF A SHORTAGE OR A PROBLEM, CALL – in the USA: (800) 527-2100

PLEASE FOLLOW THESE INSTRUCTIONS:

- A. ON CALLS YOU WILL NEED TO GIVE THE FOLLOWING INFORMATION.
1. Name and title of person calling.
 2. Phone number of person calling.
 3. Business name.
 4. Street address.
 5. City, State, Zip.
 6. Model Number (from serial plate).
 7. Serial Number (from serial plate).
 8. Date purchased (if serial number indicates date of manufacture is over 13 months old you will be asked to supply proof of purchase)
 9. Purchased from.
- B. FOR SHORTAGE – SUPPLY THE ABOVE INFORMATION AND FULLY EXPLAIN WHAT IS MISSING. It will be sent immediately – prepaid via UPS or equivalent. (Next Day Air or Priority shipments available at customer's expense).
- C. FOR EQUIPMENT PROBLEM – IF WITHIN ONE YEAR FROM DATE OF PURCHASE, THIS UNIT FAILS TO FUNCTION, YOU ARE ENTITLED TO – YOUR CHOICE OF 1, 2, OR 3.

1. **APW Wyott will replace the unit.**

When calling the factory, besides the above information you will need Electrical Characteristics, voltage and phase; describe the problems the best you can. The factory will require a *Visa or Master Card number and expiration date of same to assure return and/or validity of condition. Upon validation of credit card information, factory will strive to ship a replacement unit the same day if call is received before 3:00 p.m. Central Time or the next day if later. The replacement unit will be shipped prepaid regular UPS or equivalent. If requested Next Day Air or Priority, shipment will be made at customer's expense. Upon receipt it is the customer's responsibility to unpack the new unit taking care to preserve the packaging. Repack the unit being replaced in the same container using caution to pack properly and return this unit to the factory following the instructions supplied. Factory will supply return label and UPS call tag, both must be used. If original unit is returned within 30 days and is as represented the credit card validation will be canceled.

***IMPORTANT** - If factory does not receive the unit to be returned within 30 days, the unit will be billed to the credit card number supplied. If the returned unit is not as represented - i.e. out of warranty, customer abuse, then it will be billed to the credit card number supplied. In these cases, the person calling in the problem will be contacted and if applicable the returned unit if charged for will be returned to the original owner if requested.

2. You may take this unit to the APW Wyott Authorized Service Distributor. List of same is included with each product. If the problem is covered under warranty the unit will be repaired at no cost to you. If the Authorized Agency cannot repair same within a reasonable time while you wait, it will be returned to you prepaid, via UPS.

3. You can request the Authorized Service Distributor to service the equipment on site. If problem is covered under the warranty the parts and labor will be billed to the factory, the mileage and travel time will be responsibility of the owner.

THIS REPLACEMENT WARRANTY IS ONLY AVAILABLE ON SELECTED PRODUCTS SHIPPED WITHIN THE CONTINENTAL USA, ALASKA, HAWAII AND CANADA. AS WITH MOST WARRANTIES - WARRANTY IS ONLY VALID TO THE ORIGINAL END-USER/OWNER.

INSTRUCTIONS AND PROCEDURES MUST BE FOLLOWED OR THE WARRANTY IS VOID.

TABLE OF CONTENTS



















SECTION	ITEM.....PAGE	SECTION	ITEM.....PAGE
1	Important Safety Instructions. 3	6	Specifications 6
2	General Information 5	7	Troubleshooting 7
3	Installation Instructions 5	8	Parts List with Exploded View 8
4	Operation Instructions 5	9	Wiring Diagram 9
5	Cleaning Instructions 6	10	Warranty 11

















SAFETY PRECAUTIONS

Before installing and operating this equipment be sure everyone involved in its operation is fully trained and is aware of all precautions. Accidents & problems can result by a failure to follow fundamental rules and precautions.

Shut off gas flow through the appliance before cleaning or servicing unit.

The following words and symbols, found in this manual, alert you to hazards to the operator, service personnel or the equipment. The words are defined as follows:

	DANGER: This symbol warns of imminent hazard which will result in serious injury or death.	
	WARNING: This symbol refers to a potential hazard or unsafe practice, which could result in serious injury or death.	
	CAUTION: This symbol refers to a potential hazard or unsafe practice, which may result in or moderate injury or product or property damage.	
	NOTICE: This symbol refers to information that needs special attention or must be fully understood even though not dangerous.	
	IMPORTANT: Read the following important safety instructions to avoid personal injury or death, and to avoid damage to the equipment or property.	
	WARNING: APW Wyott toasters are designed, built, and sold for commercial use. If positioned where the general public can use them, make sure that all cautions, warnings, and operating instructions are clearly posted near each unit to insure proper operation, reduce the chance of personal injury and/or equipment damage.	
	WARNING: Plug unit into a properly grounded electrical outlet of the correct voltage, size and plug configuration. If the plug and receptacle do not match, contact a qualified electrician to determine the proper voltage and size and install the proper electrical outlet.	
	WARNING: Unit is not waterproof. Do not submerge in water. Do not operate if it has been submerged in water. Do not clean the unit with a water jet.	
	WARNING: To avoid any injury, turn the power switch off at the fuse disconnect switch/ circuit breaker or unplug the unit from the power source and allow to cool completely before performing any maintenance or cleaning.	
	WARNING: To avoid electrical shock, always unplug the unit before performing cleaning or maintenance.	

	WARNING: For safe and proper operation, the unit must be located a reasonable distance from combustible walls and materials. If safe distances are not maintained, discoloration or combustion could occur.	
	WARNING: An earthing cable must connect the appliance to all other units in the complete installation and from there to an independent earth connection.	
	WARNING: To avoid electrical shock or personal injury, do not steam clean or use excessive water on the unit.	
	WARNING: If service is required on this unit, contact your authorized APW Wyott Service Agent, or contact the APW Wyott Service Department directly at (800) 527-2100.	
	WARNING: This product has no “user” serviceable parts. To avoid damage to the unit or injury to personnel, use only Authorized APW Wyott Service Agents and genuine APW Wyott Parts when service is required.	
	WARNING: Genuine APW Wyott Replacement Parts are specified to operate safely in the environments in which they are used. Some aftermarket or generic replacement parts do not have the characteristics that will allow them to operate safely in APW Wyott equipment. It is essential to use APW Wyott Replacement Parts when repairing APW Wyott equipment. Failure to use APW Wyott Replacement Parts may subject operators of the equipment to hazardous electrical voltage, resulting in electrical shock or burn.	
	CAUTION: Some exterior surfaces on the unit will get hot. Use caution when touching these areas to avoid injury.	
	CAUTION: Locate the unit at the proper counter height, in an area that is convenient for use. The location should be level to prevent the unit or its contents from accidentally falling, and strong enough to support the weight of the unit and food.	
	WARNING: In Europe, appliance must be connected by an earthing cable to all other units in the complete installation and thence to an independent earth connection in compliance with EN 60335-1 and/or local codes.	
	CAUTION: The National Sanitation Foundation (NSF) requires that units over 36” (91 cm) in length or weighing more than 80 lbs. (36 kg) to be either sealed or raised on the installation surface. If this unit cannot be sealed at the point of use, 4” (10 cm) legs are included to allow for proper cleaning access below unit.	
	CAUTION: Use only non-abrasive cleaners. Abrasive cleaners could scratch the finish of your unit, marring its appearance and making it susceptible to dirt accumulation.	
	WARNING: Failure to provide clearances will cause unit failure and invalidate warranty claims (see installation instructions).	
	NOTICE: Do not use toppings (butter, etc.) on product as product is inverted during normal operation.	
	NOTICE: Operating toaster without legs invalidates any warranty claims.	
	NOTICE: Neglecting to keep fan opening clean could result in toaster failure.	

2. GENERAL INFORMATION

- Overall Dimensions w/Wire Feeder - 13.610”H (34.5cm) x 15.192” W (38.6cm) x 17.982” D (45.7cm)
- Product Opening - 1.50”H (3.8cm) x 10.50” W (26.7cm)
- Electrical Requirements (Single phase):
 - 120 Volt, 1800 Watt, 15 Amp.
 - 208 Volt, 1800 Watt, 8.5 Amp.
 - 230/240 Volt, 1800 Watt, 7.8 Amp.
 - Cordset configuration
 - Each toaster equipped with three wire grounded cordset and standard three-prong plug.
 - In the U.S.: 120V uses NEMA 5-15P. 208, 230/240V uses NEMA 6-20P.
 - In Canada: 120V uses NEMA 5-20P.
- Net/Shipping Weight - 28 lb.(12.7kg) / 33 lb.(14.97kg)

3. INSTALLATION INSTRUCTIONS

- Check Contents - refer to Figure 1, account for the following parts:
 - Wire Feeder - inside Reflector Tray
 - Reflector Tray - shipped in place
 - Toast Drawer - shipped in place
 - Instruction Manual - shipped loose
- Position Wire Feeder
 - Pull out Reflector Tray
 - Rotate Wire Feeder
 - Slide Reflector Tray back
 - WARNING: Operating toaster without Reflector Tray reduces toasting capabilities.
- Toaster Placement
 - Locate toaster near a grounded receptacle of the proper configuration (see below). Plug the cordset directly into receptacle (DO NOT USE AN EXTENSION CORD).
 - In the U.S.: 120V uses NEMA 5-15R. 208, 230/240V uses NEMA 6-20R.
 - In Canada: 120V uses NEMA 5-20R.
 - Place toaster on flat surface providing following minimum clearances:
 - Base = one inch (provided with legs installed).
 - Side and back walls = two inches
 - Overhead = Enough space to allow adequate heat displacement.
 - Position toaster where customers will not contact any surface labeled “CAUTION HOT”.

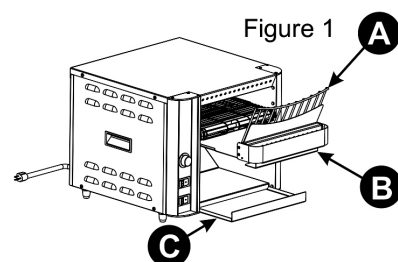

4. OPERATION INSTRUCTIONS

- Preparation
 - Clean toaster thoroughly before first use (See cleaning instructions).
 - Controls Familiarity
 - Main Power Switch (located on very bottom of control panel): There are two rocker switches. The bottom switch powers the unit “ON”. It also turns on the bottom element. The top switch is a standby switch (upper heat switch) that runs the top element. When the standby switch is in the “ON” position the unit is at full power. When the standby switch is in the “OFF” position the unit is running at 50%.
 - Full Power: Flip both rocker switches to the right.
 - Power Off: Flip both rocker switches to the left.
 - Conveyor Speed Control: Set knob to the three (3) position for warm-up.
 - Warm-up time: Allow five (5) minutes.

2. Normal Use

A. Loading Product

1. Place product on Wire Feeder. The conveyor will automatically draw product through the toaster at a speed determined by conveyor speed control.

B. Toasting Darkness: determined by conveyor speed.

1. Darkest toasting - set conveyor speed control to far left setting.
2. Lightest toasting - set conveyor speed control to far right setting.
3. Other factors affecting toasting darkness.
 - A. Product moistness - moister product requires slower speeds
 - B. Sugar content in product - product with more sugar requires slower speeds
 - C. Product Temperature - cooler product requires slower speeds
4. For best results, use day old bread stored room temperature.

5. CLEANING INSTRUCTIONS

1. Daily Cleaning

- A. With toaster off and cool, turn toaster on and set conveyor speed to four.
- B. Using a plastic abrasive pad, wipe the conveyor belt in a back and forth motion (side-to-side) motion to remove baked-on product. Wipe the conveyor belt in the same manner with a hot, damp cloth.
- C. Turn off toaster.
- D. Slide the reflector/crumb tray out of toaster by pulling forward. Dispose of crumbs and wash tray in hot, soapy water. Dry tray and place back in toaster.
- E. Remove toast drawer from toaster by sliding out and lifting up. Dispose of crumbs and wash drawer in hot, soapy water. Wipe crumbs from inside the toaster with a hot, damp cloth. Dry drawer and place back in toaster.
- F. Wipe the exterior surfaces of the toaster with a hot, damp cloth.

6. SPECIFICATIONS

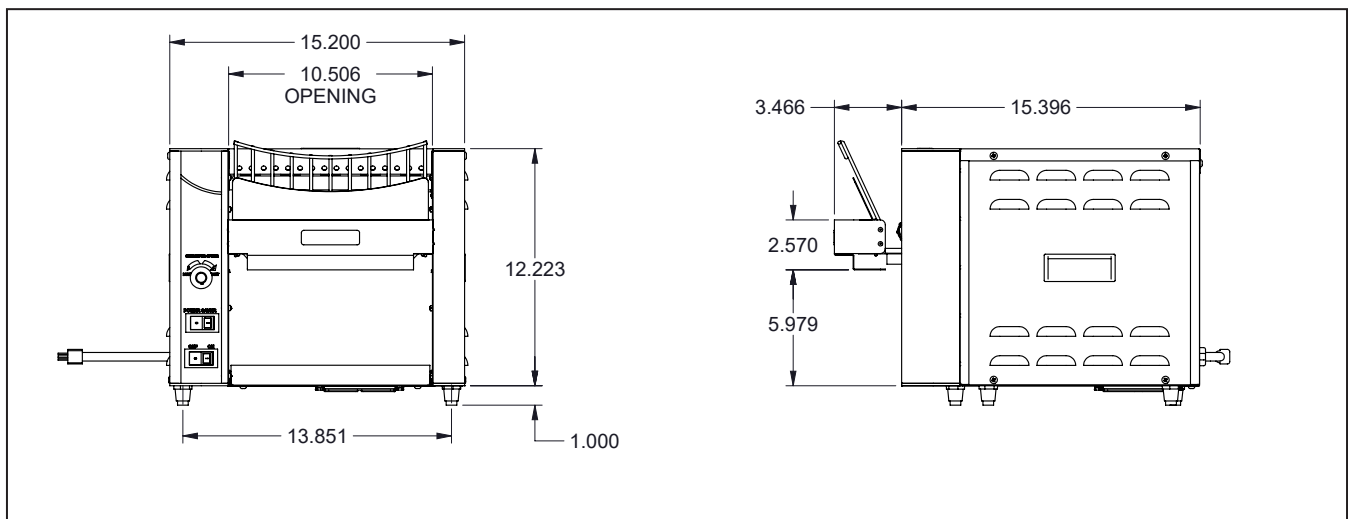

7. TROUBLESHOOTING

1. Always ask and check the following:
 - A. Is the unit connected to a live power source?
 - B. Check the circuit breaker.
 - C. Is power switch on?
 - D. Is the unit operating on proper voltage?
2. If problems exist after checking the above, check the chart below.
3. If any service is needed (italicized items), call an APW Wyott authorized service agency. All service should be performed by an APW Wyott authorized service agency.

PROBLEM	CAUSE	SOLUTION
Won't toast...	a. Toaster cold.	a. Allow five (5) minutes for warm up.
	b. Wrong power switch position.	b. Position power switch to full power.
	c. Wrong conveyor speed setting.	c. Reduce conveyor speed.
Toasts unevenly...	d. Only part of product surface is toasted.	d. Reduce conveyor speed.
	e. Product located too far to side of conveyor.	e. Place product on conveyor between end links.
Product sticks to conveyor or slide.	f. Butter or butter substitute used on product.	f. Discontinue use of butter or butter substitute.
	g. Conveyor surface has baked-on oil residue.	g. Follow daily cleaning methods to remove & prevent residue.
	h. Very moist or doughy product.	h. Use different source or day old product.
	i. Product not defrosted or thawed.	i. Defrost/thaw product.
No power...	j. No power to receptacle.	j. Check circuit breaker.
	k. Toaster unplugged.	k. Plug in toaster.
	l. Loose connections.	l. Check connections.
	m. Power switch.	m. Check that switch is on & operational.
Won't heat...	n. Loose connections.	n. Check connections.
	o. Faulty power switch.	o. Replace power switch
	p. Burnt out element.	p. Replace element.
Lighter toast under peak loads...	q. Speed control setting.	q. Reduce speed control setting.
	r. Very moist product.	r. Use different source or day old product.
	s. Product too cold.	s. Allow product to warm to room temperature.
	t. Toaster cavity temperature being quenched.	t. Add 1" or more spacing between product.
Conveyor won't move...	u. No power.	u. Check circuit breaker.
	v. Conveyor links are binding.	v. Check conveyor for bent links.
	w. Loose or bad connection between speed control and conveyor motor.	w. Check for loose or bad connection.
	x. Conveyor motor burnt out.	x. Replace conveyor motor.
	y. Speed control burnt out.	y. Replace speed control.

8. PARTS LIST WITH EXPLODED VIEW

EXPLODED VIEW

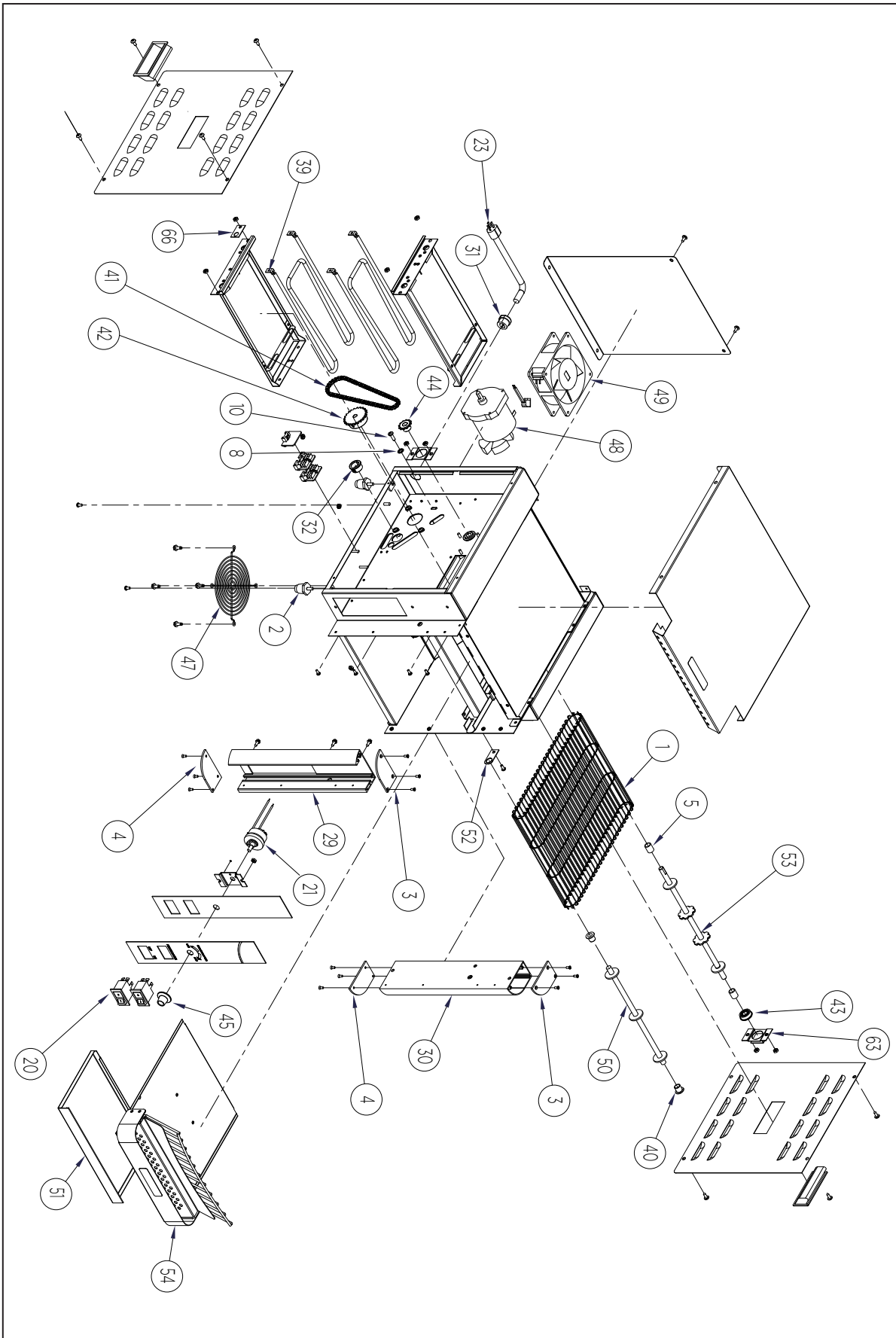

Item	P/N	Description	Qty
1	82920	WIRE- BELT-BT15-2-EIN	1.6667 FT
2	83267	LEG 1" PLASTIC W/CHROME	4
3	93000225	END CAP, F/L & B/R	2
4	93000226	END CAP, B/L & F/R	2
5	93300058	SPACER, CONVEYOR SHAFT DRIVE SIDE	2
8	8507900	WASHER, LOCK 1/4 INTERNAL	4
10	89006	SCREW, 10-24x5/8 PAN HD SLOT	4
20	70444800	SWITCH, ROCKER	2
21	83221	RHEOSTAT, MOTOR CONTROL 120V	1
23	85638	CORDSET 14/3 300V .440 DIA SJO 515P	1
	55302	CORD ASSY 120V 14/3 5-20P (120CA)	1
	83277	CORDSET ASSY (CORD 85640) (208V & 240V)	1
29	93100160	XPRS-CONTROL PANEL EXTRUSION	1
30	93100162	XPRS-, LEFT SIDE EXTRUSION	1
31	89111	STRAIN RELIEF BUSHING (HEYCO)	1
32	8978400	BUSHING, SNAP	1
39	93300017	ELEMENT; 120V 832W	2
	93300053	ELEMENT; 208V 832W	2
	93300055	ELEMENT; 240V 832W	2
40	38125	BEARING FLANGED POLYMER	2
41	82901	CHAIN: 1/4 DRIVE 68 LINK	1
42	83209	SPROCKET; 23 TOOTH 1/4 PTC 5/16 DIA BORE	1
43	83248	BEARING; SHAFT	2
44	83261	SPROCKET; 12 TOOTH 1/4 PI TCH 3/8 BORE	1
45	75617	KNOB; W/NO'S. 0 TO 9	1
47	85287	FAN GUARD	1
48	85152	MOTOR; AT10 115V 60HZ 3RP M MK 5-3902	1
	85149	MOTOR; AT'S 208/240V 60HZ VARIABLE	1
49	85286	FAN;COOLING;4.5DIA.;105CF M;120V	1
50	38122	W/ASSY; IDLER SHAFT	1
51	38129	(B)DRAWER TOAST	1
52	38130	(K)CLIP BEARING	2
53	83956	DRIVE SHAFT ASSY AT-10 SEGMENTED BELT	1
54	93100058	ASSY; XPRS FEEDER	1
63	89076	WASHER, LOCK 1/4 INTERNAL	4
66	93100047	XTRM-1 ELEMENT END CAP	4

9. WIRING DIAGRAM

WIRING DIAGRAM

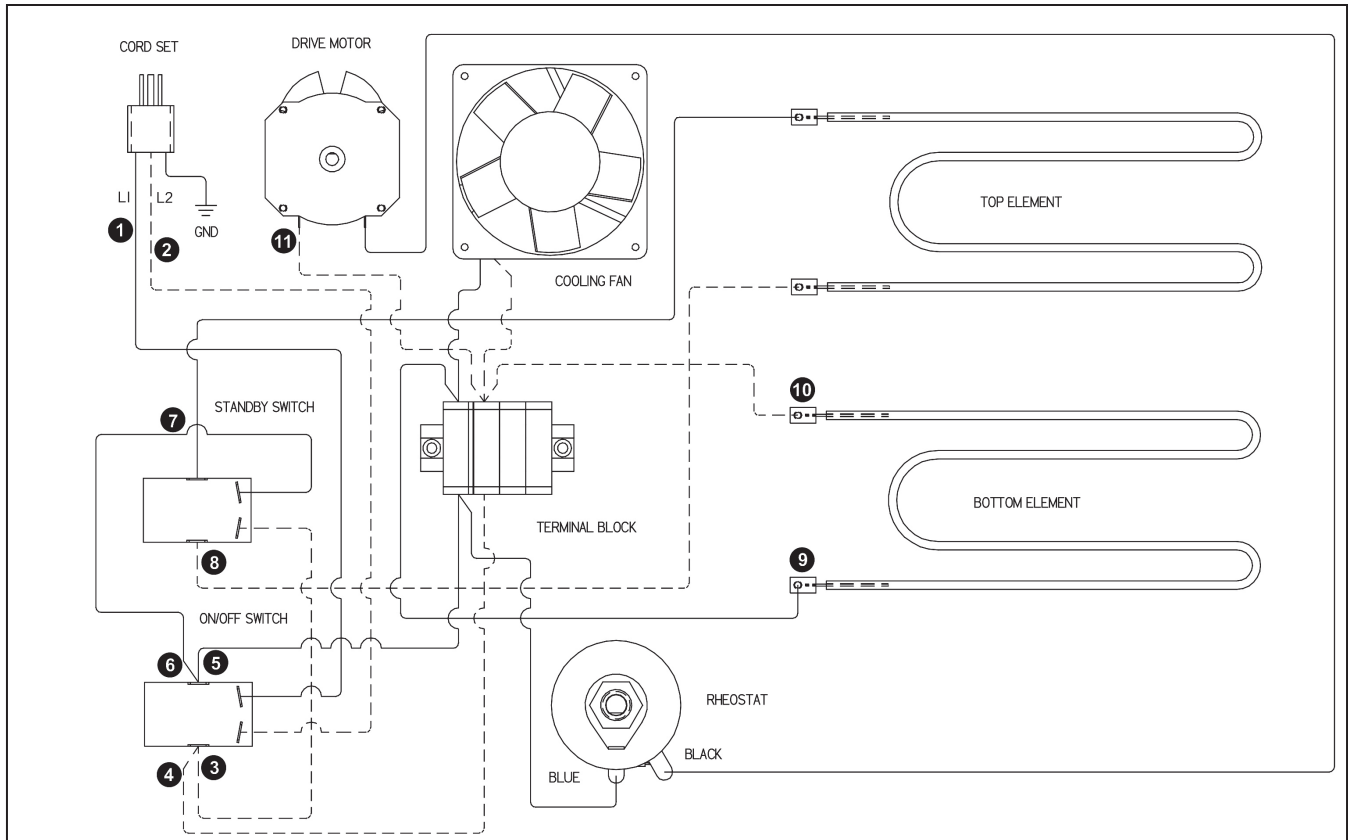

IMPORTANT NOTICE: The information contained in this section of the manual is intended for individuals possessing backgrounds of electrical and mechanical experience, such as an authorized APW Wyott service technician. APW or the seller cannot be responsible for the interpretation of this information, nor can it assume any liability in connection with its use.

IMPORTANT FOR FUTURE REFERENCE

Please complete this information and retain this manual for the life of the equipment. For Warranty Service and/or Parts, this information is required.

_____ Model Number

_____ Serial Number

_____ Date Purchased

APW Wyott takes pride in the design and quality of our products. When used as intended and with proper care and maintenance, you will experience years of reliable operation from this equipment. To ensure best results, it is important that you read and follow the instructions in this manual carefully. Installation and start-up should be performed by a qualified installer who thoroughly read, understands and follows these instructions.

If you have questions concerning the installation, operation, maintenance or service of this product, contact APW Wyott Foodservice Equipment Company's "Technical Service Department".

LIMITED EQUIPMENT WARRANTY

APW (as well as its subsidiaries) warrants to the original purchaser of new APW's products to be free from defects in material or workmanship, under normal and proper use and maintenance service as specified by APW and upon proper installation and start-up in accordance with the instructions supplied with each APW unit. APW's obligation under this warranty is limited to a period of one [1] year beginning from the date of original installation. The warranty period begins upon the earlier of the date of original installation or up to six [6] months after the original shipment, from the factory, of the covered product. Defects that occur as a result of normal use, within the time period and limitations defined in this warranty, will at APW's discretion have the parts replaced or repaired by APW or a APW's-authorized service agency.

THIS WARRANTY IS SUBJECT TO ALL LISTED CONDITIONS

Repairs performed under this warranty are to be performed by an APW authorized service agency. APW will not be responsible for charges incurred or service performed by non-authorized repair agencies. In all cases, the nearest APW-authorized service agency must be used. APW will be responsible for normal labor charges incurred in the repair or replacement of a warranted product within 50 miles (80.5 km) of an authorized service agency. Time and expense charges for anything beyond that distance will be the responsibility of the owner. All labor will need to be performed during regular service hours. Any overtime premium will be charged to the owner. For all shipments outside the U.S.A. and Canada, please see the International Warranty for specific details. It is the responsibility of the owner to inspect and report any shipping damage claims, hidden or otherwise, promptly following delivery. No mileage or travel charges will be honored on any equipment that is deemed portable. In general, equipment with a cord and plug weighing less than 50 lb. (22.7 kg) is considered portable and should be taken or shipped to the closest authorized service agency, transportation prepaid.

CONTACT

Should you require any assistance regarding the operation or maintenance of any APW Manufacturing; phone or email our service department. In all correspondence provide the model number and serial number of the unit needing service; include the voltage or gas type.

Normal Business Hours: 8:00 a.m. to 5:00 p.m. Central

Telephone: 800-264-7827 Tech Service Option 2

Email: TechService@partstown.com

www.apwwyott.com

WARRANTY EXCLUSIONS

THE FOLLOWING WILL NOT BE COVERED UNDER WARRANTY.

APW's sole obligation under this warranty is limited to either repair or replacement parts, subject to the additional limitations detailed below. This warranty neither assumes nor authorizes any person to assume obligations other than those expressly covered by this warranty.

- Any product which has not been used, maintained, or installed in accordance with the directions published in the appropriate installation sheet and/or owner's manual, including incorrect gas or electrical connection. APW is not liable for any unit which has been mishandled, abused, misapplied, subjected to harsh chemicals, modified by unauthorized personnel, damaged by flood, fire, or other acts of nature [or God], or which have an altered or missing serial number.
- Installation, labor, and job checkouts, calibration of heat controls, air and gas burner/bypass/pilot adjustments, gas or electrical system checks, voltage and phase conversions, cleaning of equipment, or seasoning of griddle surface.
- Replacement of fuses or resetting of circuit breakers, safety controls, or reset buttons.
- Replacement of broken or damaged glass components, quartz heating elements, and light bulbs.
- Labor charges for all removable and consumable parts in gas charbroilers and hotplates, including but not limited to burners, grates, and radiants.
- Any labor charges incurred by delays, waiting time, or operating restrictions that hinder a service technician's ability to perform service.
- Replacement of parts that fail or are damaged due to normal wear or labor for replacement of parts that can be replaced during a daily cleaning routine, such as but not limited to silicone belts, PTFE non-stick sheets, control labels, knobs, bulbs, fuses, quartz heating elements, baskets, racks, and grease drawers.
- Any economic loss of business or profits.
- Non-OEM parts. Use of non-OEM parts without APW's approval will void the warranty.
- Units exceeding one [1] year from original installation date.

ADDITIONAL WARRANTIES

- Specific/chain-specific equipment may have additional and/or extended warranties.

The foregoing warranty is in lieu of any and all other warranties expressed or implied and constitutes the entire warranty.



APW Wyatt • www.apwwyott.com/
265 Hobson St. • Smithville, TN 37166
Telephone: (800) 527-2100

Printed in the U.S.A. • 2M-93100174 REV B (01-23)
Specifications are subject to change without notice.

APW
wyott is a registered trademark of APW Wyatt®, A Middleby Company. All rights reserved.