



Atlas Metal
INDUSTRIES, INC.

SELF-LEVELING DISPENSERS

MOBILE OPEN
PLATE DISPENSERS
TUBULAR FRAME

MOPD - unheated

MOPDH - heated

OPERATION, INSTALLATION & MAINTENANCE MANUAL

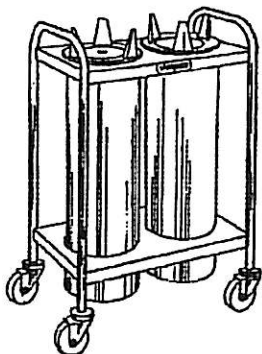

MOPD2

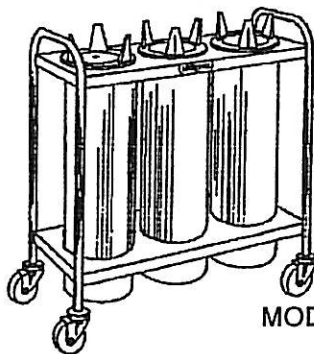

MOPD3

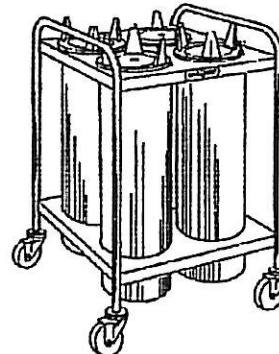

MOPD4



WARNING: READ INSTRUCTIONS COMPLETELY BEFORE OPERATION AND INSTALLATION OF YOUR DISPENSER.

NOTE: EACH SECTION OF THIS MANUAL IS PRECEDED BY "WARNING" THAT INDICATE SOME EXTRA PRECAUTIONS THAT MUST BE TAKEN IN THE OPERATION INSTALLATION & MAINTENANCE OF YOUR DISPENSER.

WARNING: INSPECT DISPENSER CAREFULLY FOR MECHANICAL OR ELECTRICAL DAMAGE.

The MOPD-Series is shipped with springs preset for the average plate, however, if further adjustments are required the dispenser is equipped with three different groups of springs that allow fine tuning of your dispensing levels. The springs are coded as follows:

"Heavyweight"	largest diameter	(silver)
"Mediumweight"	smaller diameter	(black)
"Lightweight"	smaller diameter	(silver) "fine tuning"

When adjusting springs, always completely disengage unused springs and place in spring storage area. To achieve a smooth operating dispenser, try and use the same number of springs per section.

WARNING: NEVER REMOVE SPRINGS WHEN EXTENDED:

- (1) Injury can result if spring fully disengages from dispenser.
- (2) Damage to the spring can result.

OPERATION/SPRING ADJUSTMENT:

To begin, lift dispensing tube out of the frame, for shielded models, remove outer sleeve and disconnect power cord from cabinet receptacle before adjusting. Stand dispenser on floor protecting power cord from damage, and begin loading plates. Load plates one at a time to determine comfortable dispensing height. For dispensing, TOP PLATES WHEN LOADED SHOULD BE ABOVE THE TOP FLANGE, BUT NOT HIGHER THAN THE GUIDE POSTS. After several plates have been loaded into the dispenser, a visual check can determine if dispensing height is correct.

- (a) if dispensing level remains at a constant height above the top flange, and not higher than the guide posts, when plates are loaded dispenser requires no further adjustment.
- (b) if dispensing level only rises above the guide post when plates are loaded, adjustment is required, begin to remove one of the same type of spring from each section to lower dispensing level to correct height.
- (c) if dispensing level drops below the top flange when plates are loaded again adjustment is required, begin to add springs one per section, from spares provided with dispenser.

**MOBILE OPEN
PLATE DISPENSERS
TUBULAR FRAME**

MOPD - unheated

MOPDH - heated

OPERATION/INFORMATION

INSTALLATION:

The MOPD-Series shall be constructed of a 1" stainless steel tubing, welded to a stainless steel upper and lower deck, with reinforcement channels to support the weight of the dispensing tubes. The unit is mobile for use on the serving line or the meal preparation area.

WARNING: NOTE: FOLLOWING PRECAUTIONS WHEN INSTALLING

NOW THAT SPRING ADJUSTMENTS ARE COMPLETE, REMOVE PLATES AND ...

- (1) verify that unit "IS NOT" connected to a power source.
- (2) carefully install dispensing tube into cabinet, cord first to avoid damage to the power cord "DO NOT DROP."
- (3) verify dispensing tube power switch is in off position before connecting power cord to cabinet receptacle.
- (4) verify that properly grounded electrical circuit is provided with correct voltage and amperage rating (see rating label).
- (5) install dispenser in accordance with national and local electrical codes.

OPERATION/ADJUSTMENT:

If plates in your dispenser appear to "STICK" in a down position, normally this is not the result of weak springs, but a mechanical problem caused by one of the following.

- (1) plates are binding or catching due to incorrect size of plates.
- (2) foreign object(s) in dispenser causing it to "STICK."
- (3) dispenser has been incorrectly assembled after cleaning.

WARNING: DO NOT PLACE HAND(S) IN THE DISPENSER TO "UN-STICK" AS PRESSURE COULD SUDDENLY RELEASE CAUSING INJURY.

USE THE FOLLOWING PROCEDURE TO "UN-STICK" DISPENSER.

NOTE: HEATED MODELS, TURN POWER SWITCH TO OFF POSITION AND DISCONNECT FROM ELECTRICAL SOURCE, AND DISPENSING TUBES FROM CABINET RECEPTACLE.

- (1) Carefully reload plates to relieve upward spring tension.
- (2) Dispenser must be removed from frame.
- (3) With load secured, use a tool to inspect dispenser to determine the cause of the problem and to correct it.
- (4) Carefully unload dispenser to check for smooth operation, and inspect thoroughly.
- (5) If further repairs are required, disengage all springs to avoid personal injury and/or damage to springs.

CLEANING INSTRUCTIONS:

HEATED MODELS:

- Turn power switch to off position.
- Allow adequate cool down time before cleaning.
- Disconnect cabinet from electrical source, and dispensing tubes from cabinet receptacle.
- Do not expose electrical components to moisture.
- Do not immerse in water.

TO CLEAN, WIPE DISPENSER THOROUGHLY WITH A DAMP CLOTH AND MILD SOAP SUITABLE FOR FOOD CONTACT ZONES. NO ABRASIVES."

**MOBILE OPEN
PLATE DISPENSERS
TUBULAR FRAME**

MOPD - unheated

MOPDH - heated

GENERAL INFORMATION

TROUBLE SHOOTING:

MECHANICAL:

dishes	high-low	See leveling adjustment.
dishes	"STICKING"	See operation instructions.

ELECTRICAL:

low heat/no heat	verify dispenser connected to cabinet receptacle
	verify correct voltage at power source
	verify power switch in on position
	verify circuit breaker in on position

UPON VERIFICATION AND PROBLEM PERSISTS? PUT DISPENSER OUT OF SERVICE. CALL FACTORY FOR SERVICE AUTHORIZATION. USE LICENSED QUALIFIED SERVICE PERSONNEL ONLY!

PARTS LIST

DESCRIPTION	PART #	DESCRIPTION	PART #
ON-OFF SWITCH	117-1	DISPENSER HEADS	
SWITCH COVER	117-2	PD-5	LM2964-A02
THERMOSTAT	2047	PD-5 3/4	LM2965-A02
IND. LIGHT	1100-3	PD-6 1/2	LM2966-A02
CORDSET	1006-3	PD-7 1/4	LM2967-A02
PLATE GUIDE	119-0001	PD-8 1/8	LM2968-A02
SPRING "HEAVY"	103-932	PD-9 1/8	LM2969-A02
SPRING "MEDIUM"	103-930	PD-10 1/8	LM2970-A02
SPRING "LIGHT"	103-931	PD-12	LM2972-A02
HEATING ELEMENT (120v)			
PDH-5	111-1211	PDH-8 1/8	111-1215
PDH-5 3/4	111-1212	PDH-9 1/8	111-1045
PDH-6 1/2	111-1213	PDH-10 1/8	111-1216
PDH-7 1/4	111-1214	PDH-12	12-1217

SPECIFICATIONS

FRAME -- unheated

Top frame shall be constructed of 16 gauge 1" o.d. stainless steel tubing. The upper and lower deck, shall be of 16 gauge 18-8 stainless steel welded to the tubular frame, with a heavy duty reinforcement channel for added strength. All models shall be supplied with 4" non-marking heavy duty swivel casters.

FRAME -- heated

The heated dispenser cabinet shall have the same specifications, with the addition of a receptacle attached in the underside of upper deck. A six foot 3-wire grounded electrical supply cord 16-3 is standard, except 3-tube models sizes 10 1/8" to 12" and 4 tube models 8 1/8" to 10 1/8" shall have 14-3 electrical supply cords and NEMA 5-15p for 120v. The 4-tube model 12" size shall have 12-3 electrical supply cord and NEMA 5-20p for 120v.

DISPENSING TUBE -- unheated

The basic unit shall be constructed of 300 series stainless steel. The counter top flange has three high impact molded plastic guide posts to keep plates properly aligned. Self leveling spring mechanism is easy to field adjust to accommodate different weights of plates. A combination of extension strings will be provided for field adjusting to required self-leveling height. The drop in plate dispenser shall be self-supporting using a formed stainless steel top flange welded to the vertical channels and bottom disc. A stainless steel platform will be suspended from the extension springs and will support the stack of plates to be dispensed.

DISPENSING TUBE -- heated

Same specifications as "unheated" with the addition of a heating element mounted in the base and an adjustable thermostat located in a vertical side channel. A pilot light and on-off switch located in the top flange. A power cord is NEMA 5-15p for 120 volt units.

MOBILE OPEN PLATE DISPENSERS TUBULAR FRAME

MOPD - unheated
MOPDH - heated

SPECIFICATIONS

2-STACK MOBILE OPEN PLATE DISPENSER							
MAX DISH DIA.	2-STACK UNHEATED	L	W	WT.	2-STACK HEATED	120Vv/elec WATTS/AMPS WT.	
5"	MOPD2- 5	24 5/8	x 15 1/8	75	MOPD2H- 5	420	3.5 87
5 3/4"	MOPD2- 5 3/4	24 5/8	x 15 1/8	79	MOPD2H- 5 3/4	480	4.0 93
6-1/2"	MOPD2- 6 1/2	24 5/8	x 15 1/8	83	MOPD2H- 6 1/2	540	4.5 93
7 1/4"	MOPD2- 7 1/4	24 5/8	x 15 1/8	83	MOPD2H- 7 1/4	600	5.0 95
8 1/8"	MOPD2- 8 1/8	30 3/8	x 16 1/8	98	MOPD2H- 8 1/8	660	5.5 102
9 1/8"	MOPD2- 9 1/8	30 3/8	x 16 1/8	100	MOPD2H- 9 1/8	760	6.3 104
10 1/8"	MOPD2-10 1/8	30 3/8	x 16 1/8	102	MOPD2H-10 1/8	840	7.0 104
12"	MOPD2-12"	34 1/8	x 18	109	MOPD2H-12	1000	8.3 113

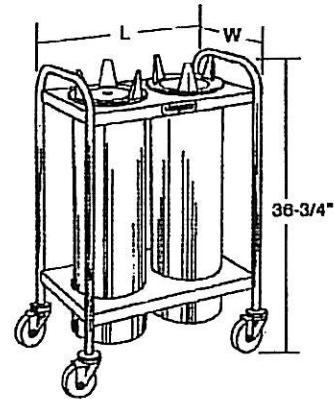

3-STACK MOBILE OPEN PLATE DISPENSER							
MAX DISH DIA.	3-STACK UNHEATED	L	W	WT.	3-STACK HEATED	120Vv/elec WATTS/AMPS WT.	
5"	MOPD3- 5	36	x 15 1/8	98	MOPD3H- 5	630	5.3 116
5 3/4"	MOPD3- 5 3/4	36	x 15 1/8	104	MOPD3H- 5 3/4	720	6.0 125
6-1/2"	MOPD3- 6 1/2	36	x 15 1/8	110	MOPD3H- 6 1/2	810	6.8 125
7 1/4"	MOPD3- 7 1/4	36	x 15 1/8	110	MOPD3H- 7 1/4	900	7.5 128
8 1/8"	MOPD3- 8 1/8	44 5/8	x 16 1/8	132	MOPD3H- 8 1/8	990	8.3 138
9 1/8"	MOPD3- 9 1/8	44 5/8	x 16 1/8	135	MOPD3H- 9 1/8	1140	9.5 141
10 1/8"	MOPD3-10 1/8	44 5/8	x 16 1/8	138	MOPD3H-10 1/8	1260	10.5 141
12"	MOPD3-12"	50 1/4	x 87	158	MOPD3H-12	1500	12.5 164

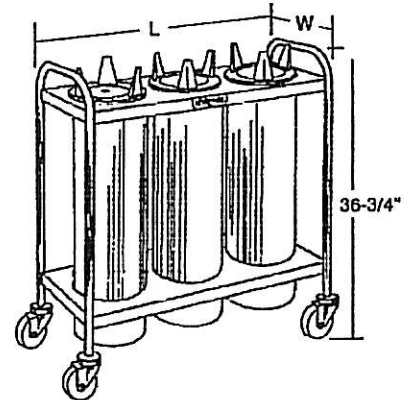

4-STACK MOBILE OPEN PLATE DISPENSER							
MAX DISH DIA.	4-STACK UNHEATED	L	W	WT.	4-STACK HEATED	120Vv/elec WATTS/AMPS WT.	
5"	MOPD4- 5	24 5/8	x 24 5/8	122	MOPD4H- 5	840	7.0 146
5 3/4"	MOPD4- 5 3/4	24 5/8	x 24 5/8	130	MOPD4H- 5 3/4	960	8.0 158
6-1/2"	MOPD4- 6 1/2	24 5/8	x 24 5/8	138	MOPD4H- 6 1/2	1080	9.0 158
7 1/4"	MOPD4- 7 1/4	24 5/8	x 24 5/8	138	MOPD4H- 7 1/4	1200	10.0 162
8 1/8"	MOPD4- 8 1/8	30 3/8	x 30 3/8	169	MOPD4H- 8 1/8	1320	11.0 177
9 1/8"	MOPD4- 9 1/8	30 3/8	x 30 3/8	173	MOPD4H- 9 1/8	1520	12.7 181
10 1/8"	MOPD4-10 1/8	30 3/8	x 30 3/8	177	MOPD4H-10 1/8	1680	14.0 181
12"	MOPD4-12"	34 1/8	x 34 1/8	197	MOPD4H-12	2000	16.7 205

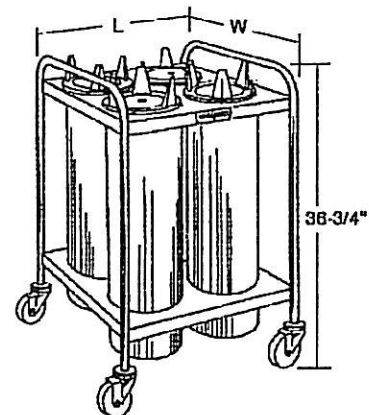

HEATED DISPENSERS

The PDH model heating system has 120v single phase heating capacity, 208v and 240v when specified. The components are a push button on-off switch, indicator light, and adjustable thermostat. The six foot 3-wire cordset is NEMA 5-15P for 120v dispensers. The dispenser is enclosed with 24 gauge stainless steel sleeve.

WIRING DIAGRAM

