



PrepPal *CookRite* Mixrite



WALK-IN INSTALLATION MANUAL



 Toll Free: (855) 855-0399
 info@atosausa.com
 www.atosausa.com

Table of Contents

Safety Notices.....	3
Warning	4
Tools Required.....	5
General Information	6
Unpacking/Inspection	6
Panel Installation	7
Constructure of Walk-In	8
Connection Methods of Panels (Camlock)	9
Operation Sequence of Panel Installation	10
Floor Panels.....	10
Floor Panels.....	11
Floor Panels.....	12
Interior Ramp	13
Wall Panels.....	14
Wall Panels.....	15
Ceiling Panels.....	16
Door Assembly.....	17
Door Section (Interior Ramp Model).....	18
Finishing Installation	19
Cleaning and Checking of Walk-In Installation	20
Exploded View	21

Safety Notices

1. **Manufacturing Standards:** Manufactured according to professional production, purchasing, and quality control standards.
2. **Engineering Principles:** The product is developed using professional engineering principles.
3. **Compliance:** It is designed to comply with industry performance and safety regulations.
4. **Testing:** Thoroughly reviewed and professionally tested for function, reliability, and safety.
5. **Customer Satisfaction:** Acknowledges that customer satisfaction is vital for the company's success.
6. **Representation:** Advertised and represented in an informational and factual manner to aid customers in product selection.
7. **Product Improvement:** Reserves the right to improve products without notice, without obligating changes to previously manufactured products.

Warning

1. **Slip Hazard:** It is important to keep the Walk-in floor free of items that could cause a slip hazard.
2. **Causes of Slipperiness:** Look out for spilled liquids, food particles, or any moisture as factors that can make the floor slippery.
3. **Preventive Measures:**
 - Inspect non-skid floor strips on ramps and surfaces, replacing if worn.
 - Inspect refrigeration system, door gaskets, and hardware for proper operation to prevent moisture.
 - Avoid leaving entry doors open for extended periods to prevent excessive condensation.
 - We recommend the use of vinyl strip curtains to reduce warm moist air entering the Walk-in.

Tools Required

- Hex Key Wrench, 5mm and 10mm
- Scissors
- Power Drill
- Swage Tool
- Caulk Gun and NSF Silicone Caulk



General Information

Thank you for purchasing the Atosa Walk-in Cooler or Freezer. The Walk-in incorporates the latest manufacturing technology and innovative design techniques to ensure optimal user convenience. The provided manual serves as a comprehensive reference guide for installation, operational information, electrical wiring details, maintenance procedures, and adjustment or replacement methods for specific components. Users are encouraged to keep this manual in a convenient file for quick reference to address any questions related to their Atosa Walk-in Cooler or Freezer. It is important to read all sections for a better understanding of the equipment in order to achieve the products expected performance.

Unpacking/Inspection

Cabinet

- Upon delivery, check the bill of lading for correct number of boxes.
- In the event of damage, be sure to notate 'damaged' on the freight bill and to take pictures of any damage and send to our Customer Service Department. It is imperative you document any and all evidence of damage.
- Remove packing list and installation pack attached to the end of the skid.



Before Installation

Once you have located the clear installation pack attached to the door, pull out the installation drawing for reference. Each panel is labeled with a number. Separate the panels by grouping (the C panels together, the W panels together, etc.). Prior to installation, ensure there is proper clearance where the Walk-in will be located.

There should be a minimum 2" clearance around exterior of panels for airflow. Before setting panels, make sure there is proper clearance for Door Swing and Heated Pressure Relief.

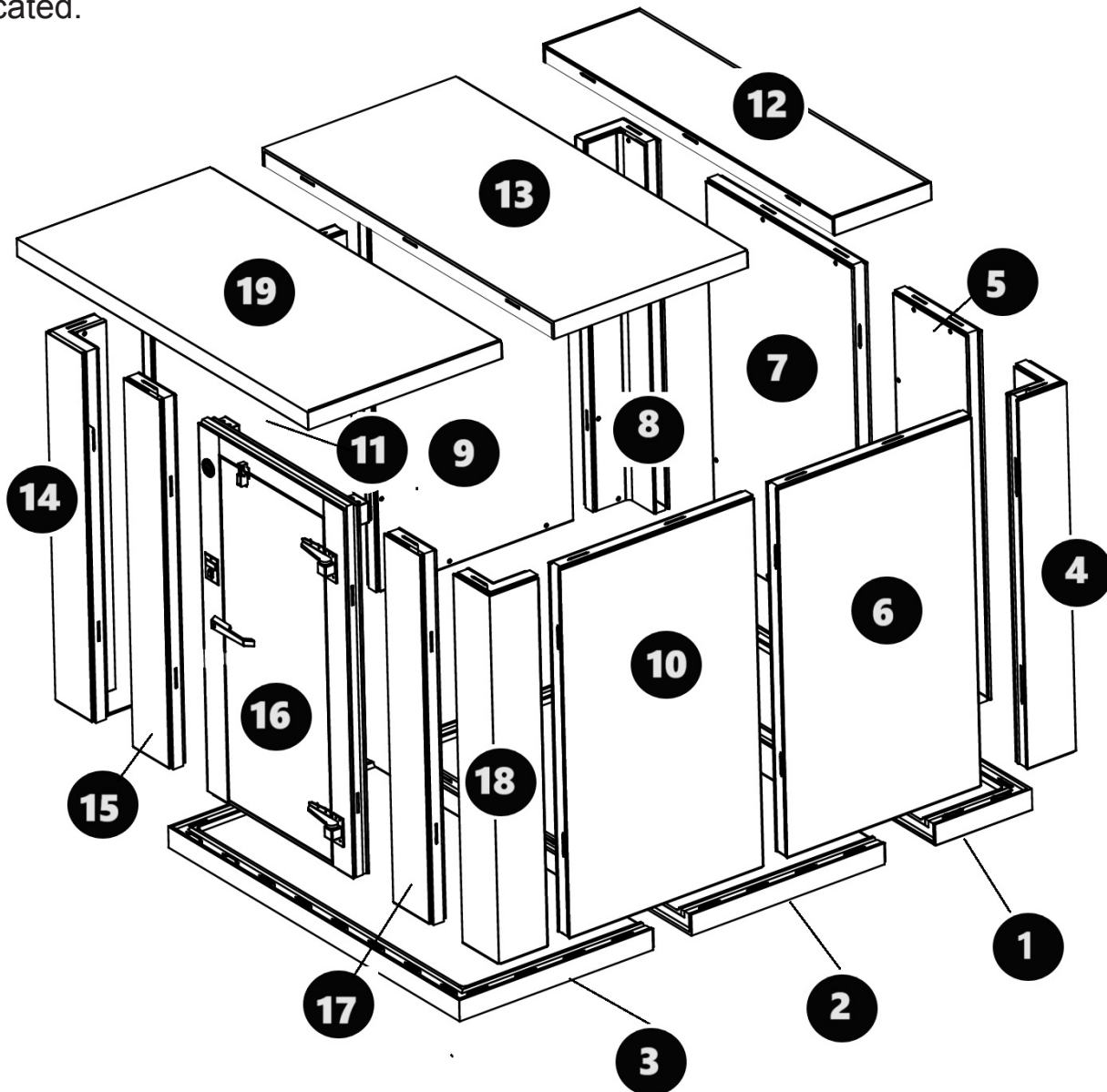

Connection Methods of Panels (Camlock)

Panels are connected tightly through camlocks, one hook of male side of panel pulls a pin and latches to the female side of another panel, which locks the two panels firmly together.

Camlocks on all floor panels and all ceiling panels are female. Three sides of the wall panel (top/bottom/right side viewed from interior) are male. Only the left side of a wall panel is female.

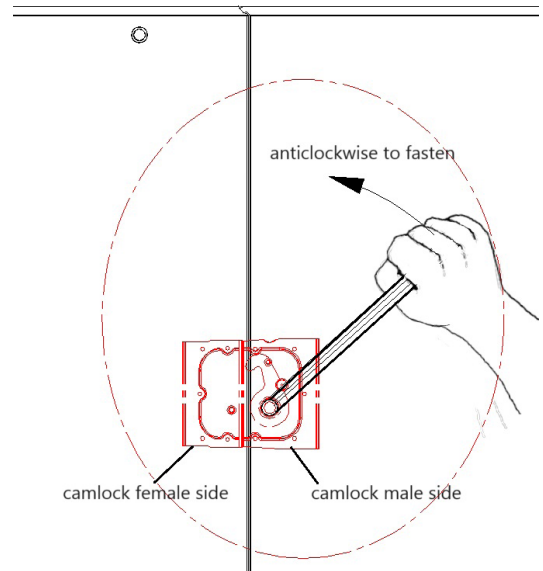

NOTE: Hex wrench provided in hardware bag

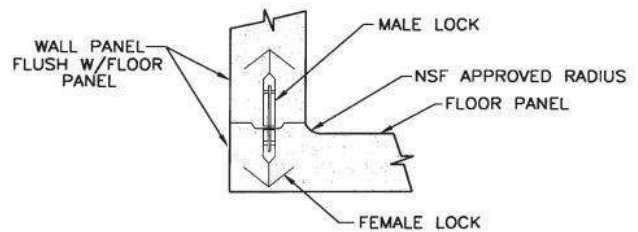
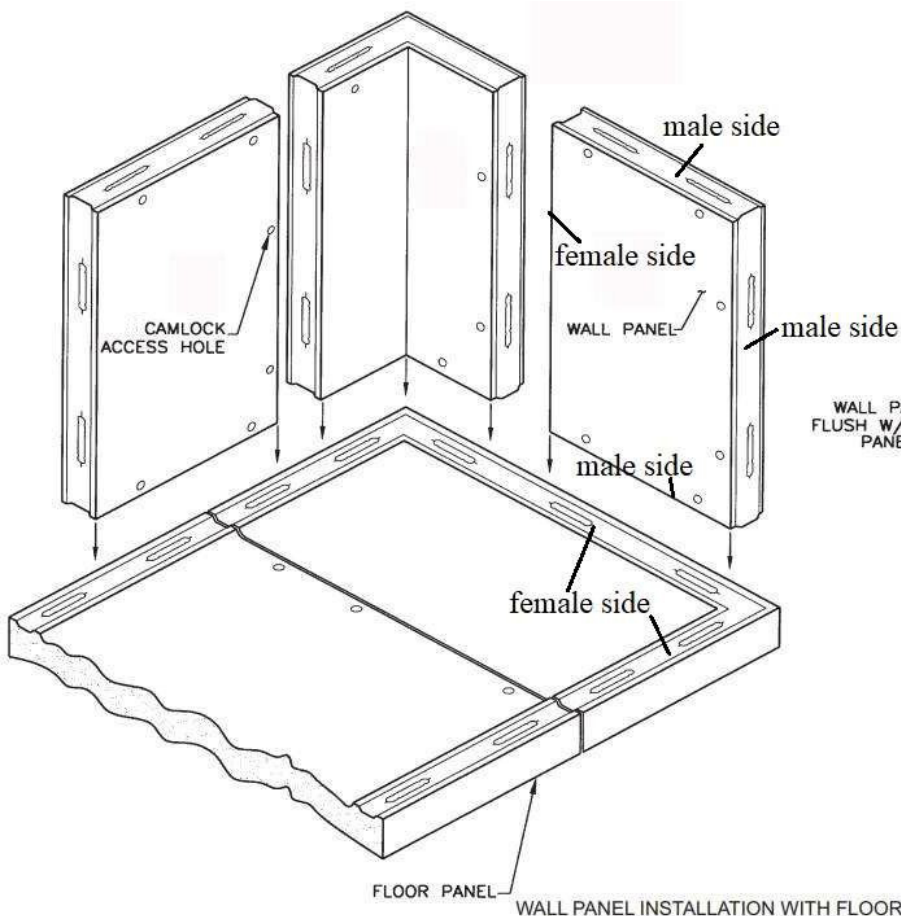

Operation Sequence of Panel Installation

Floor Panels

Leveling the Floor

In the construction of a Walk-in Cooler or Freezer, a critical factor to prioritize is the foundation, specifically the building floor or surface where the structure will be situated. Similar to any construction project, the establishment of a firm and level foundation is paramount to attain an optimal outcome. If the surface lacks perfect leveling and smoothness, it is imperative to undertake necessary measures to ensure an appropriate base. The effective operation of self-closing doors, the proper sealing of door gaskets, and the successful removal of condensation all hinge directly on the accurate and plumb installation of all panels.

NOTE: Indoor Walk-in(s) must be in an environmentally controlled space. Relative humidity should be kept between 30% - 60%, maintaining a dew point of 50°F or less.



Task Completed	Date	Comment

Floor Panels (Cont'd)

The installation surface designated for the Walk-in may have been meticulously prepared, ensuring it is impeccably level and smooth. In such cases, the Walk-in floor can be installed without additional preparation. Prior to commencing the installation, however, it is essential to place a suitable vapor barrier over the designated surface.

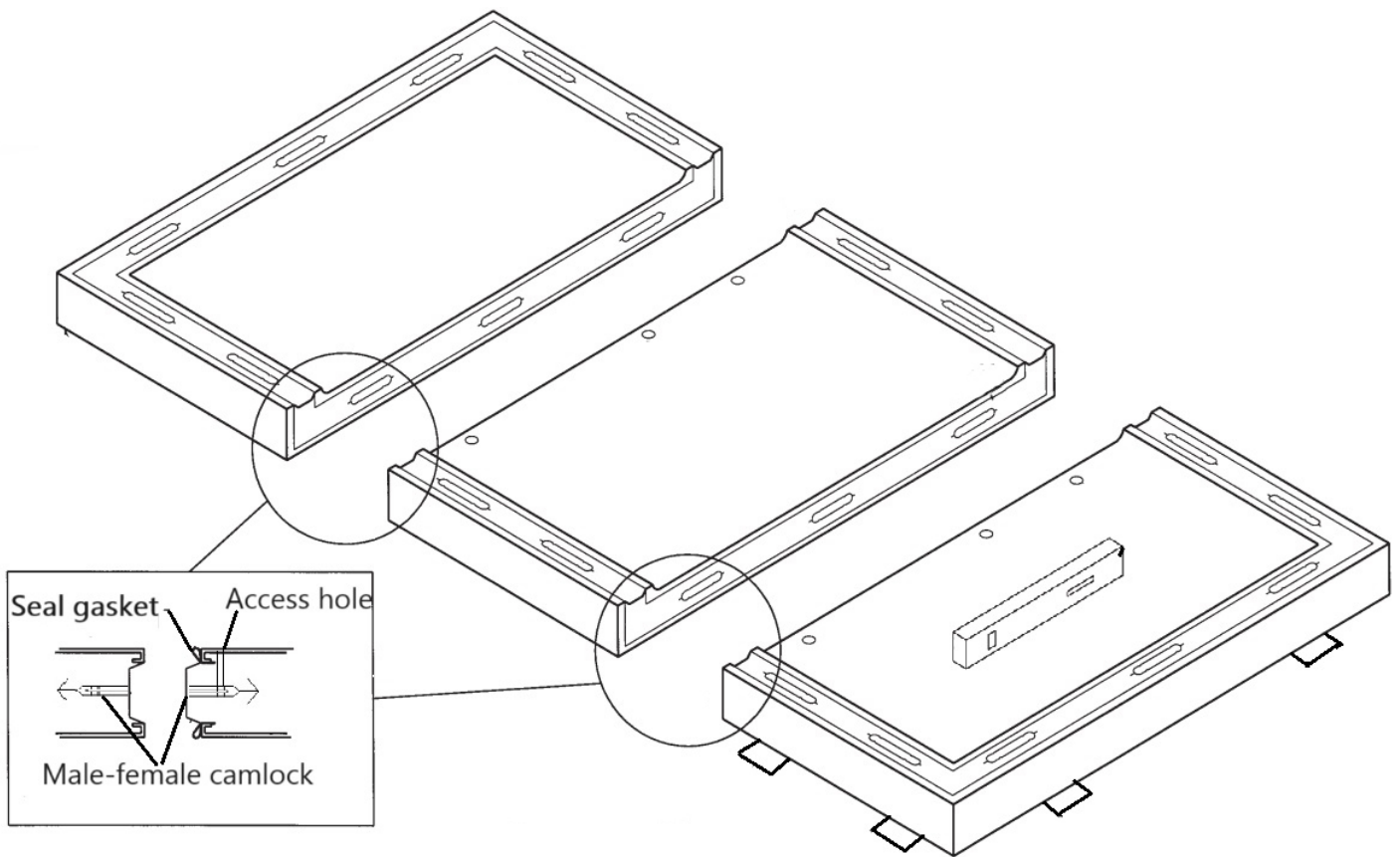

Task Completed	Date	Comment

Floor Panels (Cont'd)

Adjust the second panel as needed by shimming, using the same procedure employed for the first panel. Once all four edges of the second floor panel are appropriately shimmed, securely lock the two panels together. Utilize the identical leveling technique to assess the levelness of the two sections in all directions. This can be achieved by placing the level across the joint at various points. Additionally, reassess the levelness of the floor panels, focusing on the direction of the panel joint.

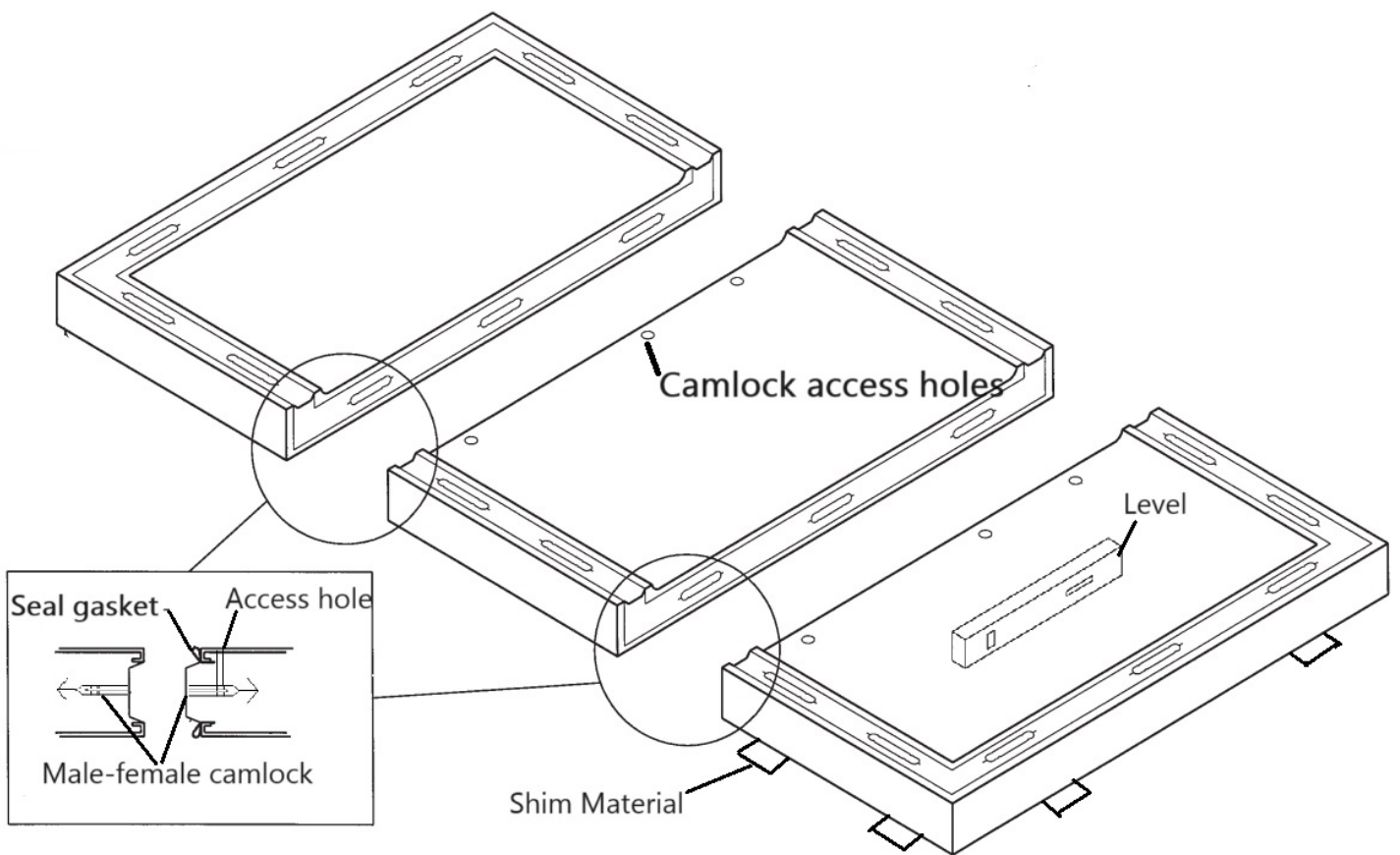

Task Completed	Date	Comment

Interior Ramp

If your Walk-in comes with an interior ramp, set up the ramp after the entire structure has been installed. The ramp is located at the entrance floor.

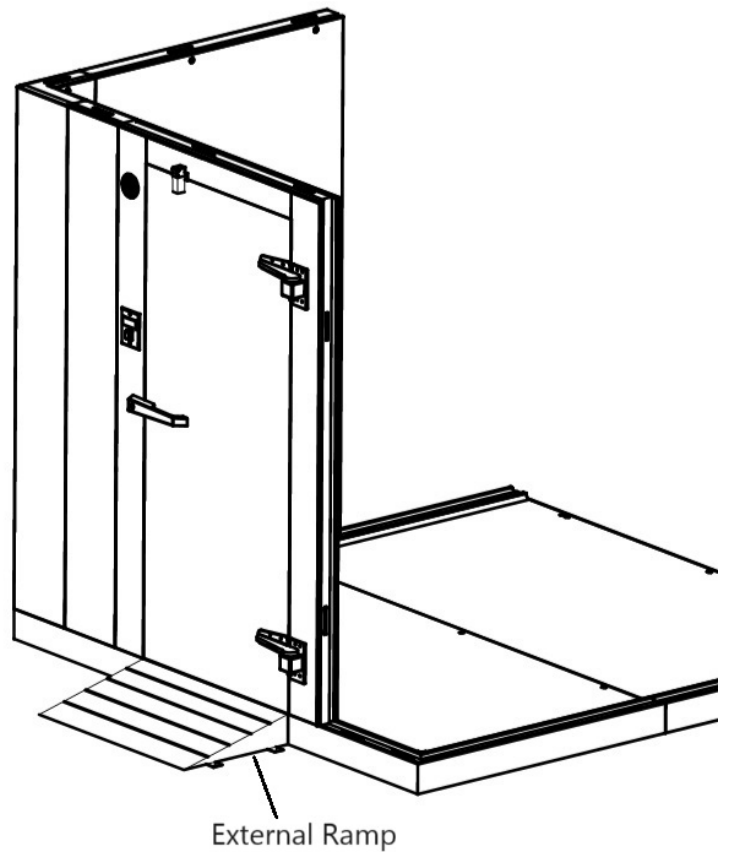
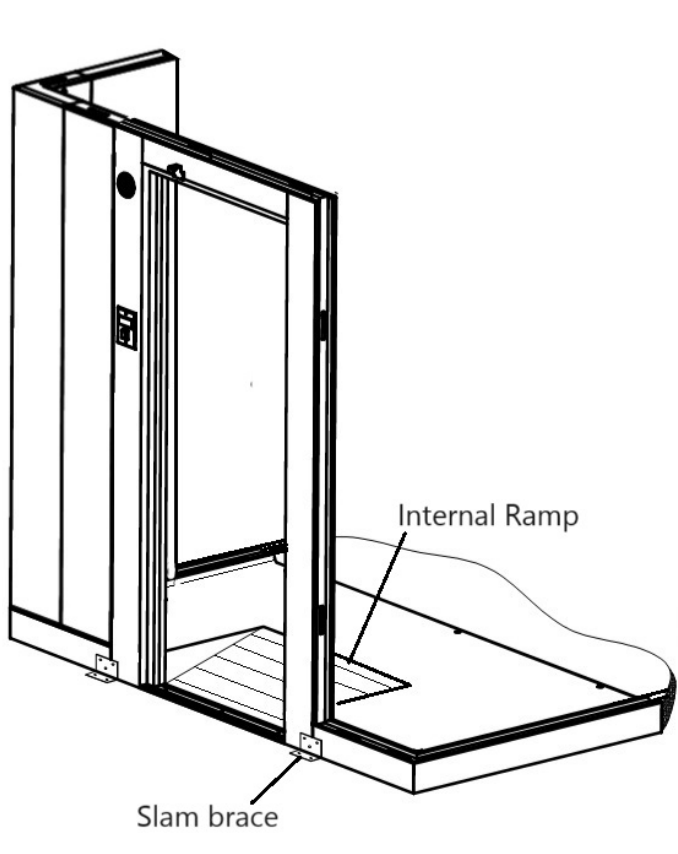

Wall Panels

To begin installing the Wall Panels, start by picking the corner panel that will be on the opposite side of the door. Set it in vertical position.

Select the next panel as indicated on the floor plan and position it on the floor or sealer (screed) close enough to the first panel installed so that section latch engagement is possible.

Make sure that the two panels are perfectly aligned at the TOP EDGE and that the VERTICAL JOINT of the two panels are perfectly flush, then turn the section latches on the vertical edge of the panel until they are completely engaged.

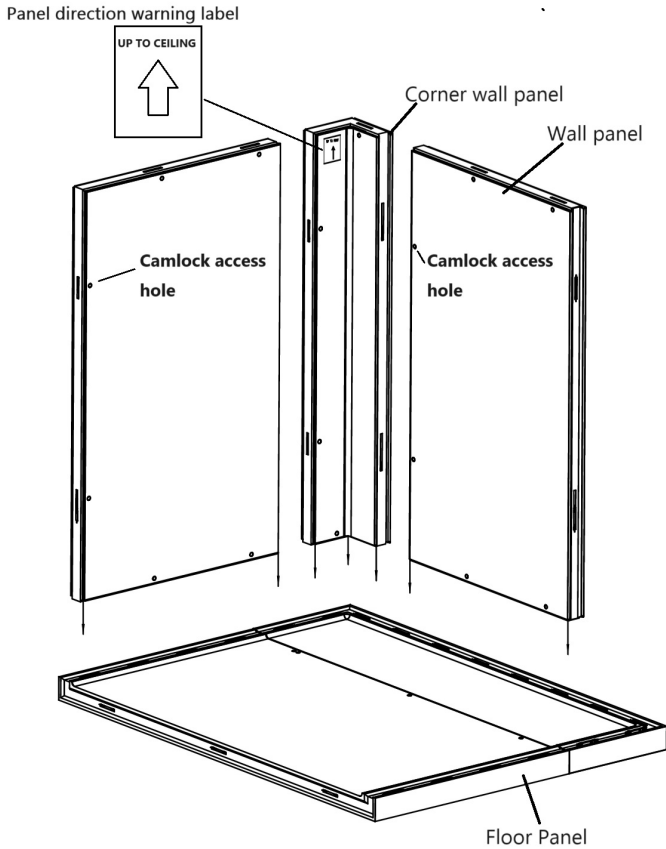

NOTE: Distinguish the upper and lower directions of the wall panels according to the signs. Usually the keyhole of each wall panel is on the left side of it.

Task Completed	Date	Comment

Wall Panels (Cont'd)

Continue constructing panels according to the Part Numbers shown on the floor plan, and explicitly follow the technique described for panel alignment.

Each wall panel or corner panel is constructed and locked in an adjoining panel along the vertical joint. Engage the section latches to the floor panels by turning the hex locking wrench.

TURN COUNTERCLOCKWISE!

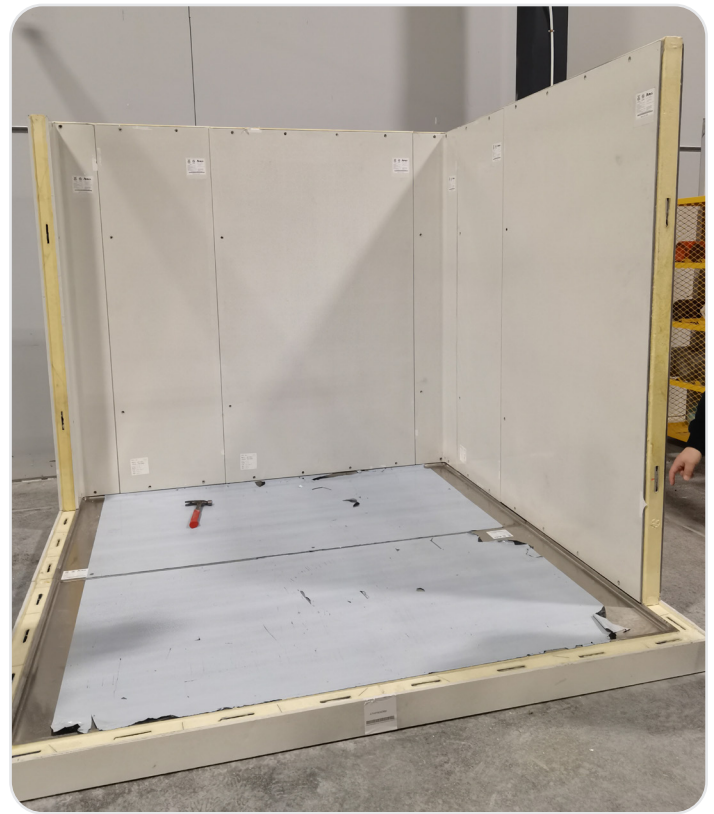

Task Completed	Date	Comment

Ceiling Panels

After installing the wall panels on three sides (the side opposite of the door and the two adjacent sides), operators can access the box through the open side. Following this, the first ceiling panel, situated at the top of the side opposite the door, should be installed. If the Walk-in configuration includes three ceiling panels, proceed to install the second ceiling panel as well.



Task Completed	Date	Comment

Door Assembly

Once you've completed the installation of the three side walls and the first two ceiling panels, you can install one front corner panel and begin the door assembly. Door assembly has hardware mounted and door locked. The door and frame are the most critical parts of the overall Walk-in structure.

A typical door, or door section, comprises a single wall panel housing an entrance door along with various accessories. The electrical components within this panel have been pre-wired at the factory, encompassing features such as the anti-condensate door opening heater, pilot light, switch, and a vapor-proof interior light. The door has undergone factory installation on the door panel framing fixture, ensuring it is squared and operates correctly under controlled conditions.

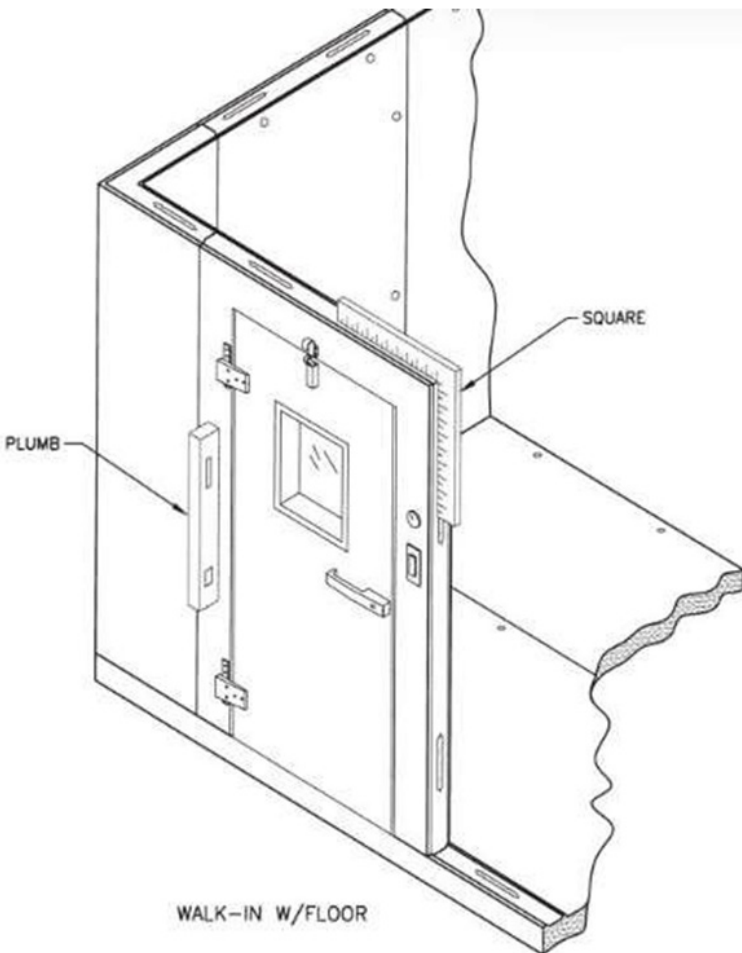

CAUTION: During the installation of the door, or door section, prevent any twisting of the panel or mishandling of the assembly that may result in an improper square alignment upon installation.

Task Completed	Date	Comment

Door Section (Interior Ramp Model)

For Interior Ramp Model, Door panel is different from the regular one. It cannot be attached and locked on the Walk-in floor panel since there is an internal ramp. This door panel is fitted with slam braces. The purpose is to locate the lower extremities of the door frames. It prevents the door panel from moving.

Level the door panel and lock it to the adjacent wall panels before start. Use Metal-to-Metal screw to fix the Slam Brace onto the door panel and attach it to the ground by Tapcon Concrete Anchor.

NOTE: Ensure the door or door section is perfectly plumb before attaching the braces to the building floor. The holes in the slam brace are intentionally round to prevent any shifting after securing. Confirm that the slam braces are firmly attached to the building floor.

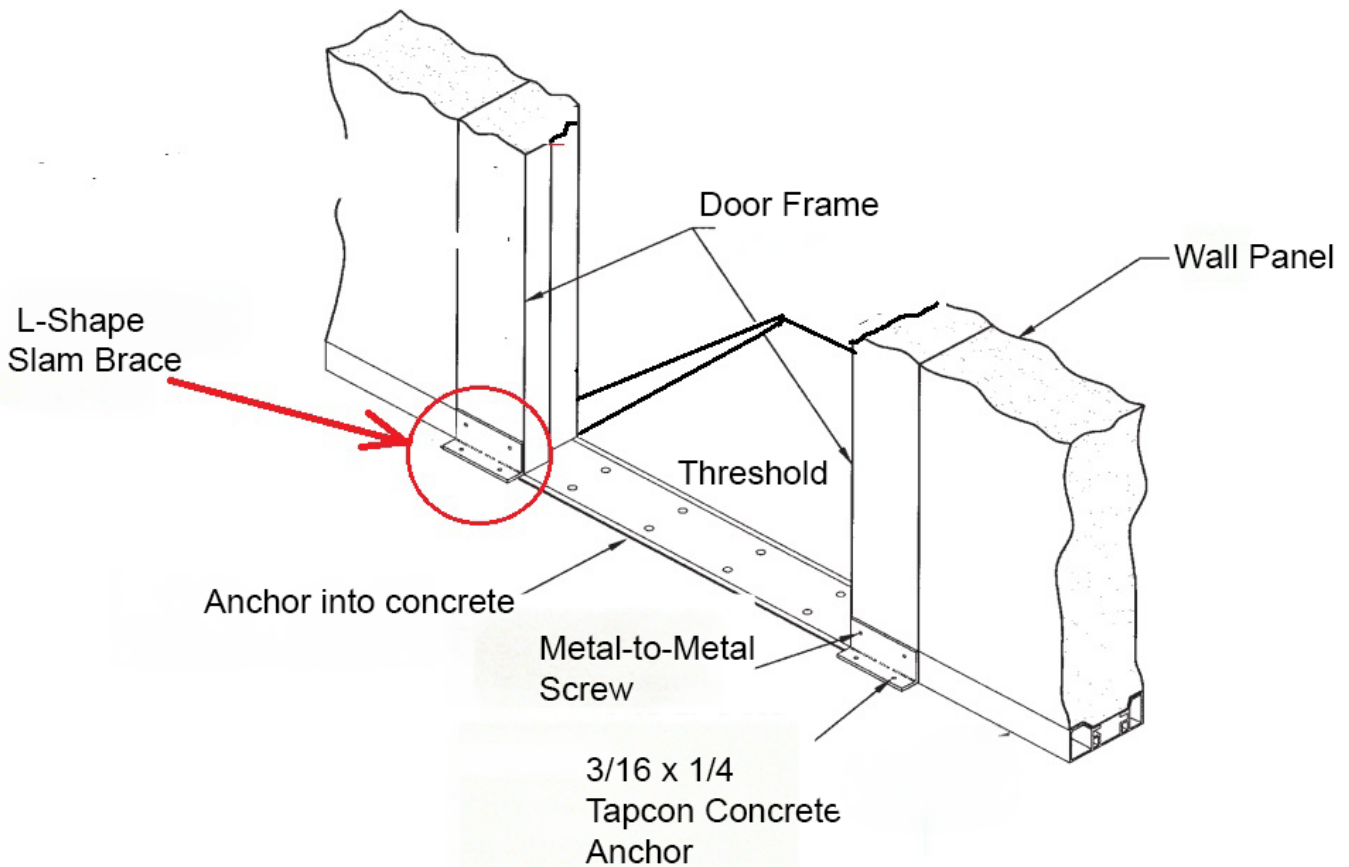

Finishing Installation

To complete your Walk-in, follow these final steps: install the last corner panel beside the door, and then proceed to install the final ceiling panel. Due to limited space, installing the last panel may be challenging. You may need to apply additional pressure and push the last panel in various directions as necessary.



Task Completed	Date	Comment

Cleaning and Checking of Walk-In Installation

After you have installed all panels and completed building your Walk-in, follow these final checks to ensure your Walk-in is clean and working properly:

- A. Don't leave any tool, parts, or rubbish on the floor or ceiling.
- B. Peel off all protective film that may remain on panels and floor.
- C. Open and close the door several times to ensure that the door hinges, door locker, door closer, and door gasket are all functioning properly.

***Please do this from the outside and with additional supervision.**

- D. Fill silicon seal at any gap according to NSF regulation.
- E. Cover the camlock access holes on panels and floor with plastic caps.



Task Completed	Date	Comment

Exploded View - AWC0606

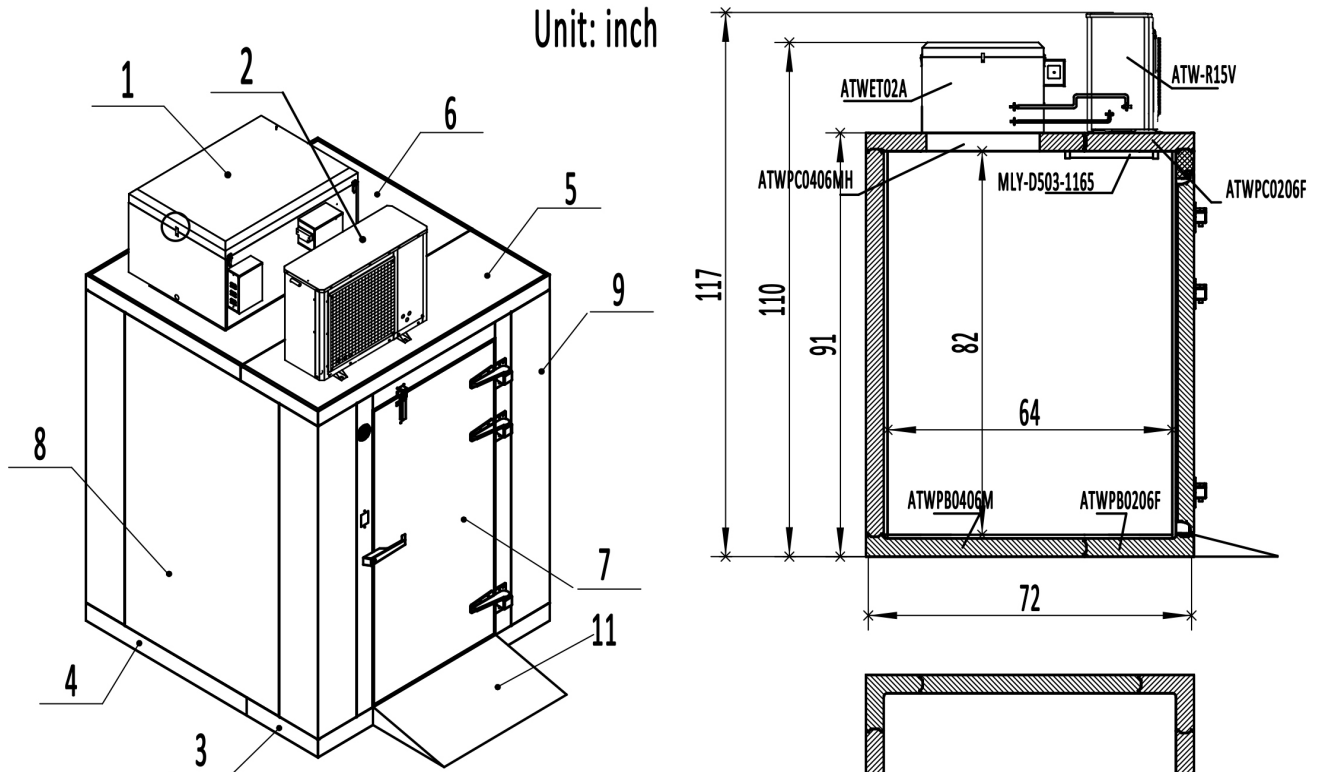

AWC0606-TF

No.	Part	Name	Qty
1	ATWET02A	Evaporating unit (Top/2 motors)	1
2	ATW-R15V	1.5 Hp Condensing unit	1
3	ATWPB0206F	Floor Panel, 2'X6', female side	1
4	ATWPB0406M	Floor Panel, 4'X6', female side	1
5	ATWPC0206F	Ceiling Panel, 2'X6', female side	1
6	ATWPC0406MH	Ceiling Panel, 4'X6', male/open hole	1
7	ATWPD0406C10-S	Door/Frame Panel, 48" Width	1
8	ATWPW0407	Wall Panel, 4' Width 48"	3
9	ATWPL0107	Corner wall panel, 12"X12"	4
10	MLYD5031165	48" LED light and wire channel	1
11	ATWA01T212000	Extend Ramp	1

	Width	Height	Height
Exterior Dimension (Including Condensing Unit)	72	72	117
Exterior Dimension	72	72	91
Interior Dimension	64	64	82

Exploded View - AWC0608

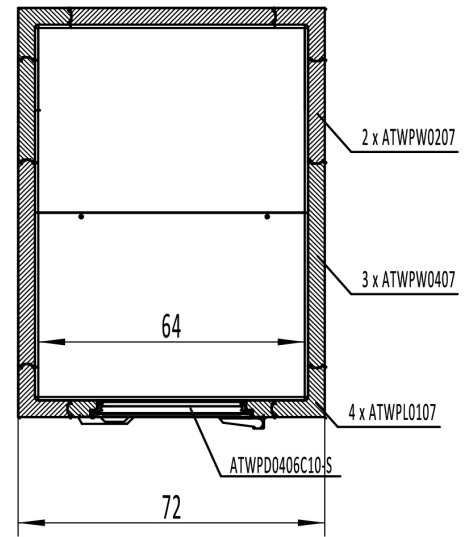
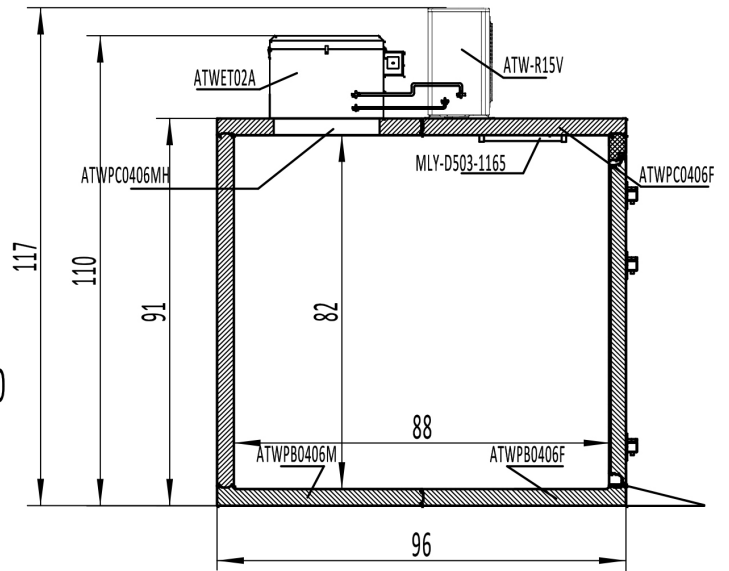
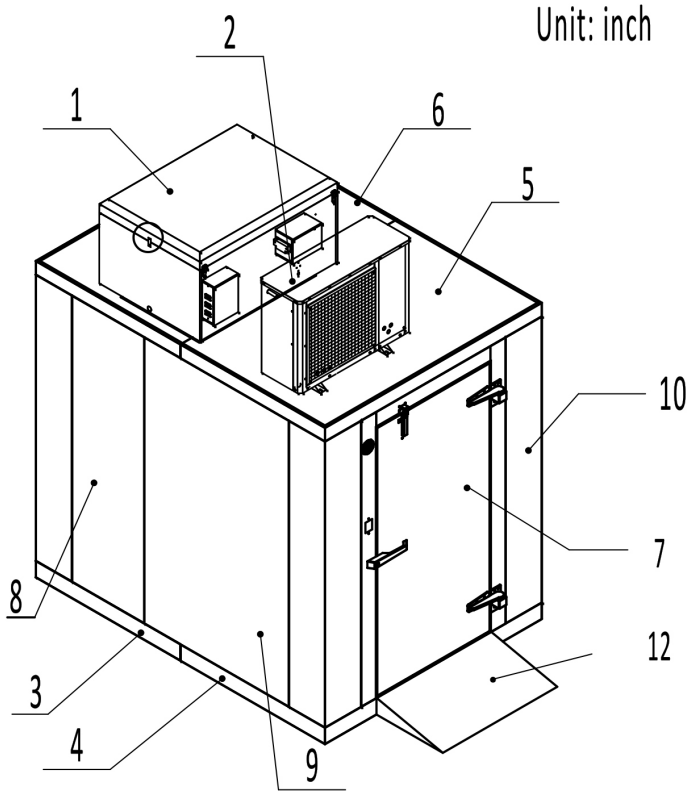

AWC0608-TF

No.	Part	Name	Qty
1	ATWET02A	Evaporating unit (Top/2 motors)	1
2	ATW-R15V	1.5 Hp Condensing unit	1
3	ATWPB0206F	Floor Panel, 4'X6', female side	1
4	ATWPB0406M	Floor Panel, 4'X6', male side	1
5	ATWPC0206F	Ceiling Panel, 4'X6', female side	1
6	ATWPC0406MH	Ceiling Panel, 4'X6', male/hole	1
7	ATWPD0406C10-S	Door/Frame Panel, 48" Width	1
8	ATWPW0207	Wall Panel, 2' Width 24"	2
9	ATWPW0407	Wall Panel, 4' Width 48"	3
10	ATWPL0107	Corner Panel	4
11	MLY-D503-1165	48" LED light and wire channel	1
12	ATWA01T212000	Extend Ramp	1

	Width	Height	Height
Exterior Dimension (Including Condensing Unit)	72	96	117
Exterior Dimension	72	96	91
Interior Dimension	64	88	82

Exploded View - AWC0808

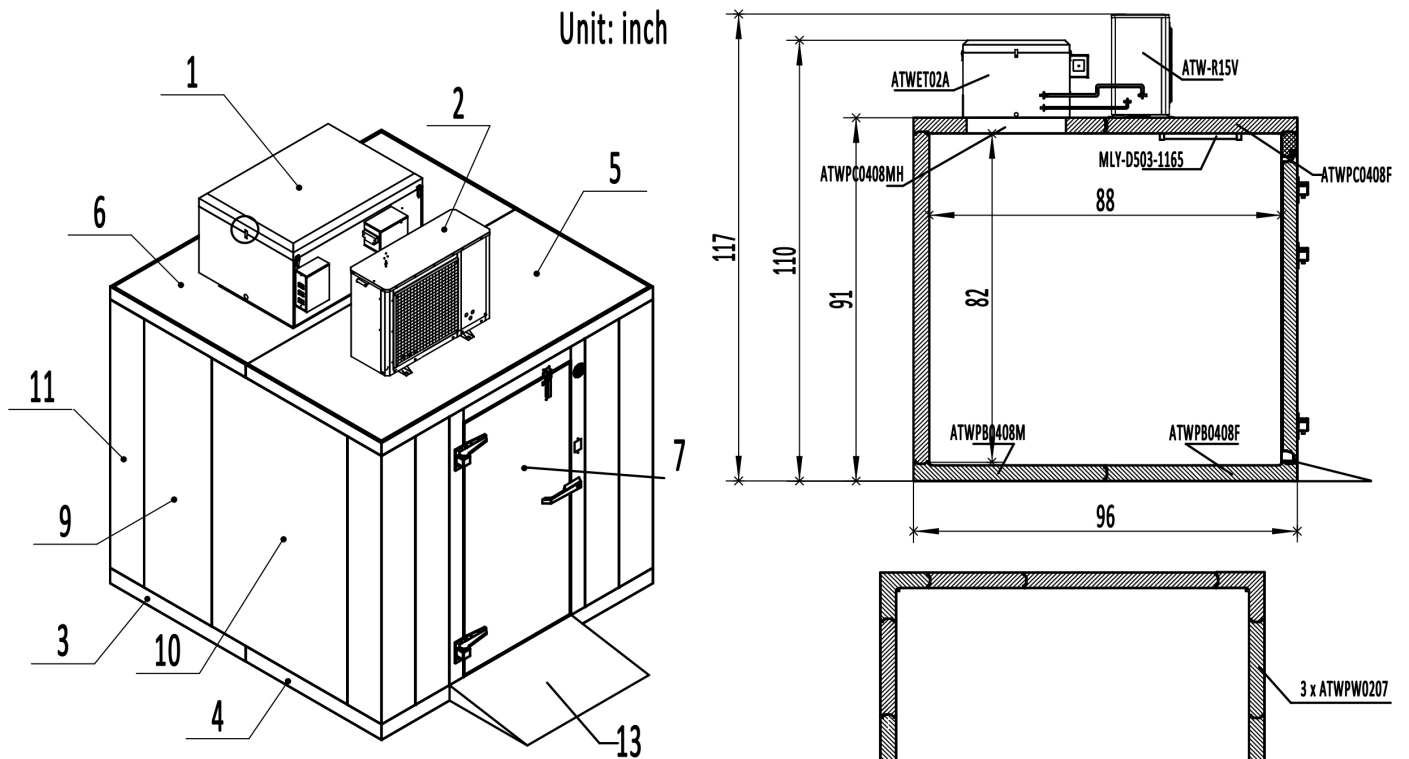

AWC0808-TF

No.	Part	Name	Qty
1	ATWET02A	Evaporating unit (Top/2 motors)	1
2	ATW-R15V	1.5 Hp Condensing unit	1
3	ATWP80408F	Floor Panel, 4'X8', female side	1
4	ATWP80408M	Floor Panel, 4'X8', male side	1
5	ATWPC0408F	Ceiling Panel, 4'X8', male side	1
6	ATWPC0408MH	Ceiling Panel, 4'X8', male/hole	1
7	ATWPD0406C10-S	Door/Frame Panel, 48" Width	1
8	ATWPW0107	Wall Panel, 1' Width 12"	2
9	ATWPW0207	Wall Panel, 2' Width 24"	3
10	ATWPW0407	Wall Panel, 4' Width 48"	3
11	ATWPL0107	Corner Panel	4
12	MLY-D503-1165	48" LED light and wire channel	1
13	ATWA01T212000	Extend Ramp	1

	Width	Height	Height
Exterior Dimension (Including Condensing Unit)	96	96	117
Exterior Dimension	96	96	91
Interior Dimension	88	88	82

Exploded View - AWC0810

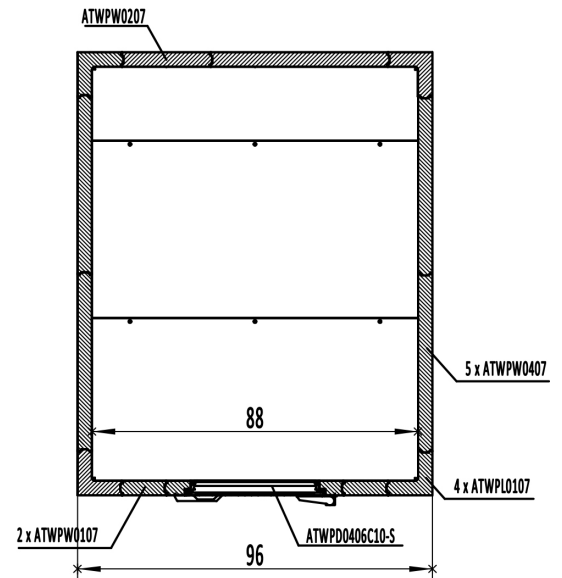
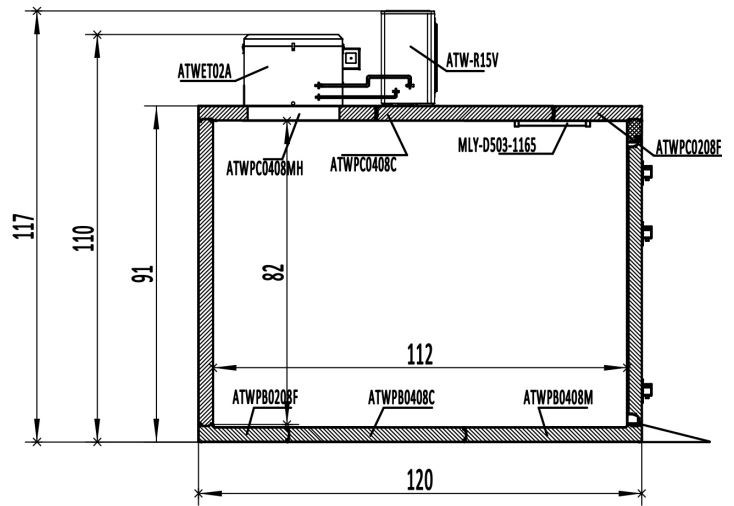
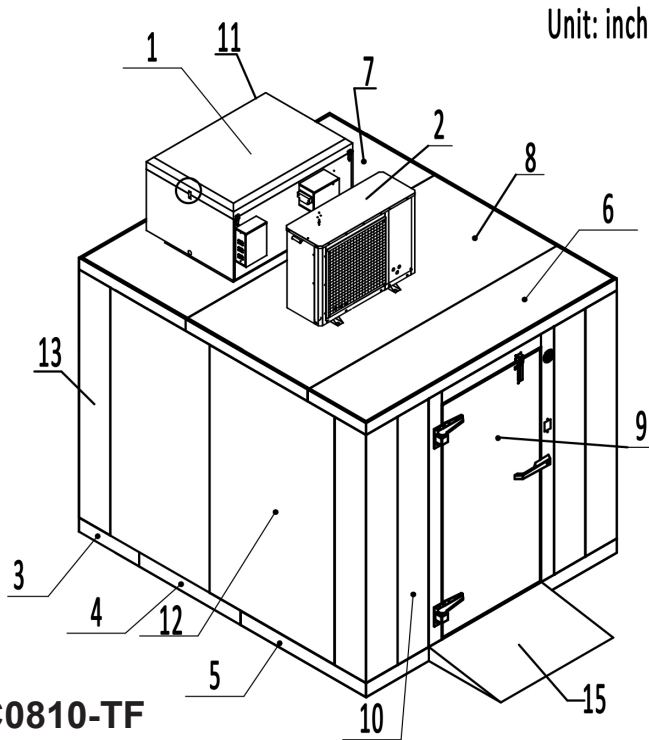

AWC0810-TF

No.	Part	Name	Qty
1	ATWET02A	Evaporating unit (Top/2 motors)	1
2	ATW-R15V	1.5 Hp Condensing unit	1
3	ATWPB0210F	Floor Panel, 2'X8', female side	1
4	ATWPB0410C	Floor Panel, 4'X8', center panel	1
5	ATWPB0410M	Floor Panel, 4'X8', male side	1
6	ATWPC0210F	Ceiling Panel, 2'X8', female side	1
7	ATWPC0410C	Ceiling Panel, 4'X8', Center	1
8	ATWPC0410MH	Ceiling Panel, 4'X8', male/hole	1
9	ATWPD0406C10-S	Door/Frame Panel, 48" Width	1
10	ATWPW0107	Wall Panel, 1' Width 12"	2
11	ATWPW0207	Wall Panel, 2' Width 24"	1
12	ATWPW0407	Wall Panel, 4' Width 48"	5
13	ATWPL0107	Corner Panel	4
14	MLY-D503-1165	48" LED light and wire channel	1
15	ATWA01T212000	Extend Ramp	1

	Width	Height	Height
Exterior Dimension (Including Condensing Unit)	96	120	117
Exterior Dimension	96	120	91
Interior Dimension	88	112	82

Exploded View - AWC1010

Unit: inch

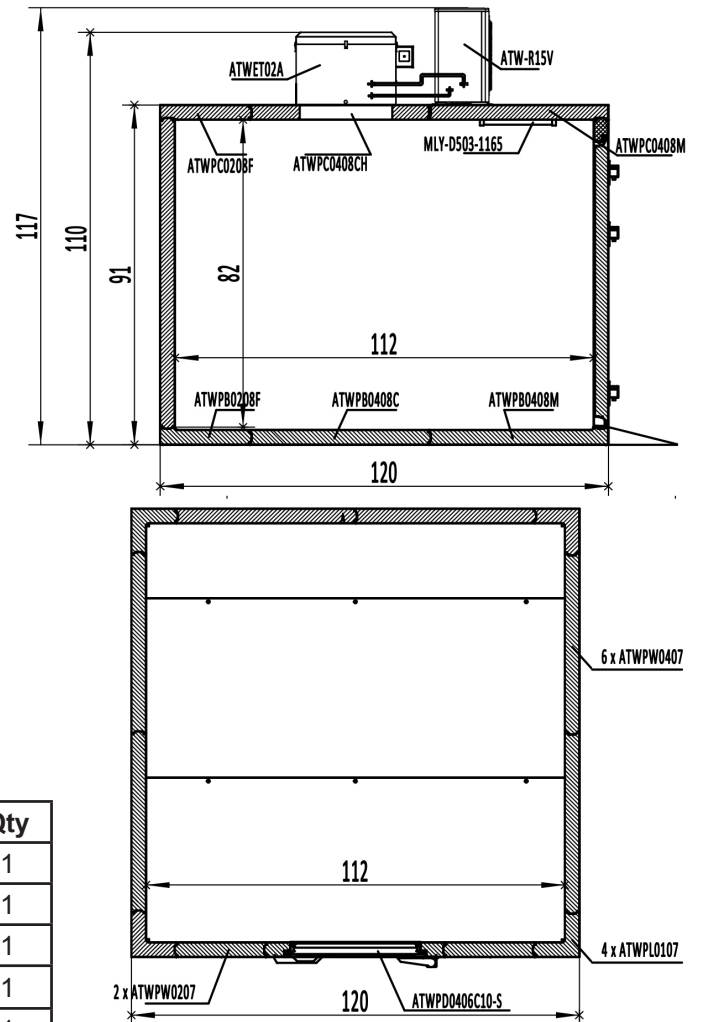
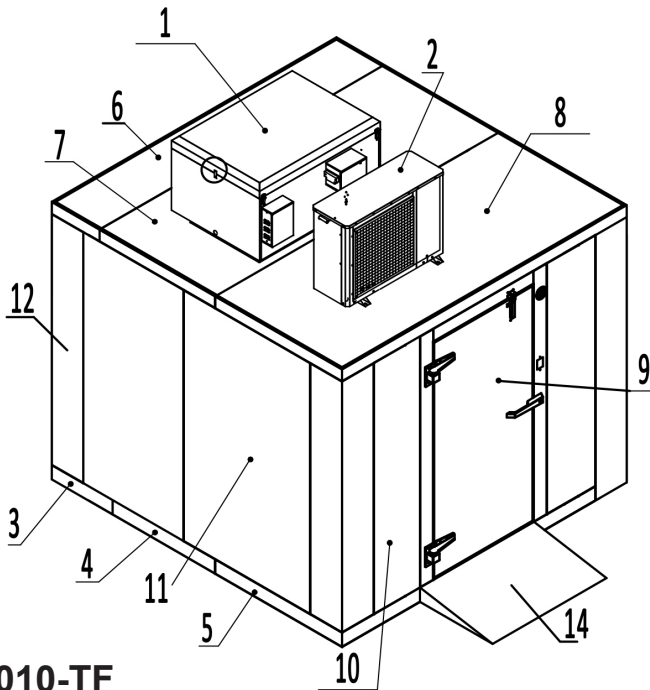

AWC01010-TF

No.	Part	Name	Qty
1	ATWET02A	Evaporating unit (Top/2 motors)	1
2	ATW-R15V	1.5 Hp Condensing unit	1
3	ATWPB0210F	Floor Panel, 2'X10', female side	1
4	ATWPB0410C	Floor Panel, 4'X10', center panel	1
5	ATWPB0410M	Floor Panel, 4'X10', male side	1
6	ATWPC0210F	Ceiling Panel, 2'X8', female side	1
7	ATWPC0410CH	Ceiling Panel, 4'X10', center/hole	1
8	ATWPC0410M	Ceiling Panel, 4'X10', male/hole	1
9	ATWPD0406C10-S	Door/Frame Panel, 48" Width	1
10	ATWPW0207	Wall Panel, 2' Width 24"	2
11	ATWPW0407	Wall Panel, 4' Width 48"	6
12	ATWPL0107	Corner Panel	4
13	MLY-D503-1165	48" LED light and wire channel	1
14	ATWA01T212000	Extend Ramp	1

	Width	Height	Height
Exterior Dimension (Including Condensing Unit)	120	120	117
Exterior Dimension	120	120	91
Interior Dimension	112	112	82

Exploded View - AWC1012

Unit: inch

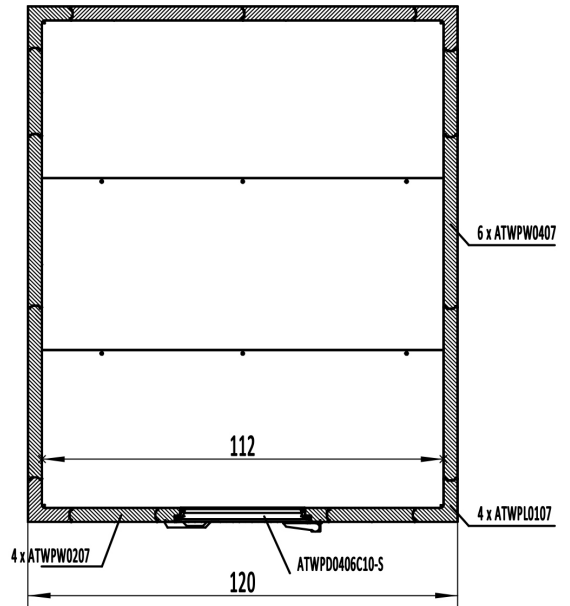
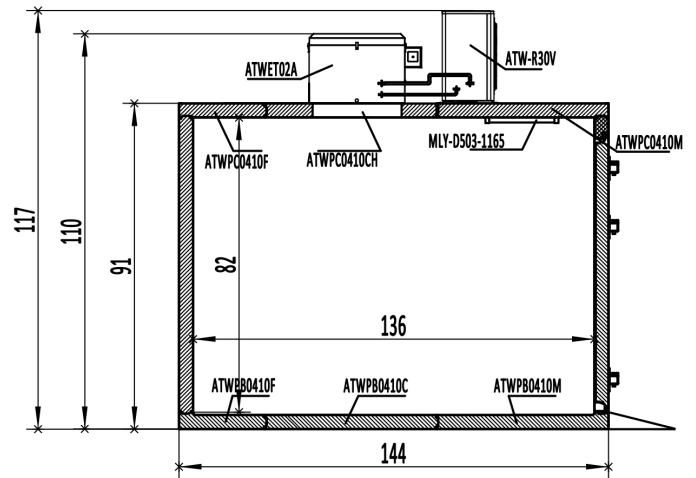
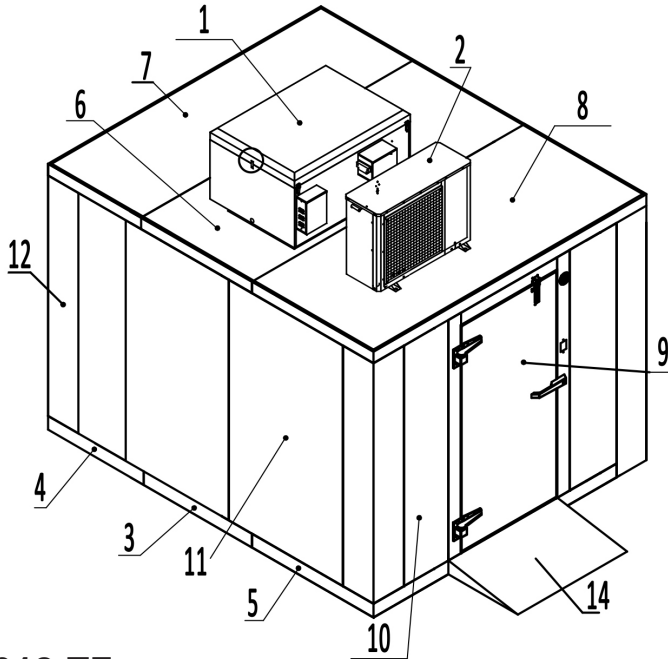

AWC1012-TF

No.	Part	Name	Qty
1	ATWET02A	Evaporating unit (Top/2 motors)	1
2	ATW-R30V	3 Hp Condensing unit	1
3	ATWPB0410C	Floor Panel, 4'X10', center panel	1
4	ATWPB0410F	Floor Panel, 4'X10', female side	1
5	ATWPB0410M	Floor Panel, 4'X10', male side	1
6	ATWPC0410CH	Ceiling Panel, 4'X10', center/hole	1
7	ATWPC0410F	Ceiling Panel, 4'X10', female side	1
8	ATWPC0410M	Ceiling Panel, 4'X10', male side	1
9	ATWPD0406C10-S	Door/Frame Panel, 48" Width	1
10	ATWPW0207	Wall Panel, 2' Width 24"	4
11	ATWPW0407	Wall Panel, 4' Width 48"	6
12	ATWPL0107	Corner Panel	4
13	MLY-D503-1165	48" LED light and wire channel	1
14	ATWA01T212000	Extend Ramp	1

	Width	Height	Height
Exterior Dimension (Including Condensing Unit)	120	144	117
Exterior Dimension	120	144	91
Interior Dimension	112	136	82



THANK YOU FOR YOUR PURCHASE OF AN ATOSA PRODUCT



 Toll Free: (855) 855-0399

 info@atosausa.com

 www.atosausa.com

R10001001400

version number 20240725





PrepPaU *CookRite* Mixrite

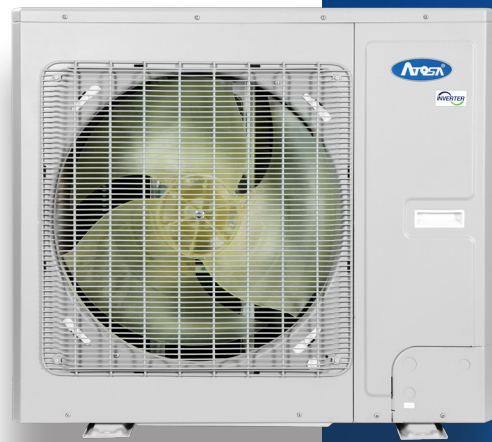

REFRIGERATION SYSTEM INSTALLATION MANUAL







TOP MOUNTED

Toll Free: (855) 855-0399
info@atosausa.com
www.atosausa.com

Table of Contents

Safety Notices.....	3
Introduction	4
General Information	5
Installation of Refrigeration System	8
Part Preparation.....	8
Spec Sheet for Condensing Unit	9
Installation of Ceiling	10
Connecting wires of Control Panel Box	11
Connecting wires of Power Supply Box.....	12
Wiring for Condensing Unit.....	13
Installation of Discharge Line Tube(Evaporating).....	15
Installation of Discharge Line Tube(Condensing).....	17
Check for Leaks.....	18
LED Installation.....	21
Wiring for 24 DCV Parts	22
Installation of Drain Pipe.....	22
Controller Setting	23
Controller Parameters Index.....	24

Safety Notices

-  The condensing unit contains refrigerant charge. Installation and brazing of the line sets must be performed by a properly trained refrigeration technician aware of the dangers of dealing with refrigerant charged equipment.
-  Equipment **MUST** be properly grounded. Improper or faulty hook-up of electrical components of the refrigeration units can result in severe injury or death.
-  All electrical wiring hook-ups must be done in accordance with all applicable local, regional, or national standards.
-  Do not operate equipment that has been misused, abused, neglected, damaged, or altered/modified from that of original manufactured specifications.

Read this manual before installing your refrigeration. Keep the manual and refer to it before doing any service. Failure to do so could result in personal injury or equipment damage.

We reserve the right to make product improvements at any time. Specifications and design are subject to change without notice.

Introduction

This series of DC inverter air-cooled condensing units are independently developed with new technology and use high-efficiency compressors. It offers the advantages of high performance, high reliability, easy maintenance, and a compact structure. It fully meets the need to provide cold sources for industrial and agricultural production as well as commercial circulation. This unit can be widely used in a variety of freezing and refrigeration applications, including fruit, meat, and vegetable preservation warehouses, fungus breeding warehouses, and other places with special refrigeration system requirements.

Operating Range

Operating Range	Outdoor ambient temperature 5~113°F(-15~45°C)
-----------------	---

Selection of Installation Position

General precautions: location of the unit should be in a place that is easy to construct, convenient for daily operation, and convenient for maintenance.

1. Distance between each unit should be as short as possible for piping and wiring.
2. Since the unit needs maintenance, please install it in an position where is easy to maintain the unit.

Please place the unit in an environment with an ambient temperature below 113 °F(45°C), in a place with good ventilation and smooth exhaust. The unit can be installed on the roof, special platform or any other location that is reliably load bearing and convenient for installation.

There should be no strong heat sources, no exhaust vents from other equipment, no strong steam or flammable gas around the unit; when the unit is placed on the roof, pay attention to the wind direction and avoid direct head wind; when installing on the ground, avoid strong air outlet as much as possible.

The installation position must ensure that the unit will not be buried in the snow and not affected by garbage and/or oil mist.

General Information

Electrical Wiring

Means for disconnection must be incorporated in the fixed wiring in accordance with the wiring rules.

For Solid Wires

1. Use a screwdriver to unscrew the terminal screw on the terminal board.
2. Use nippers to bend the solid wire into a ring that fits the terminal screw.
3. After the ring is properly formed, put it on the terminal board. Use a screwdriver to tighten up the terminal screw.

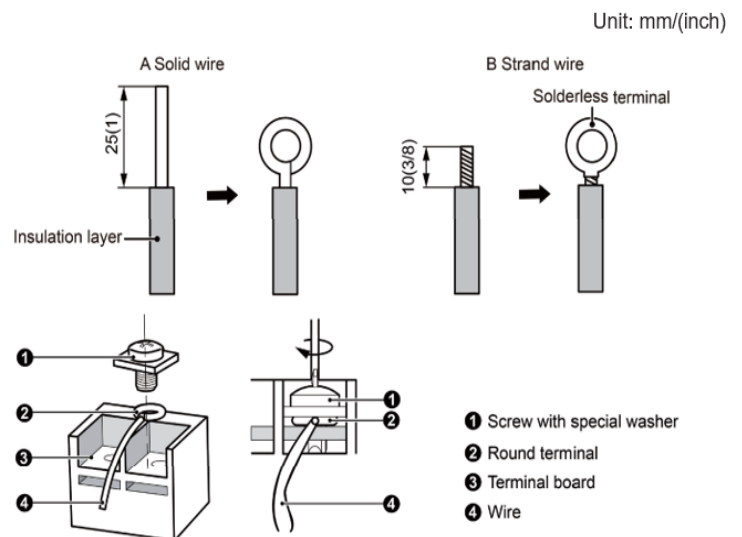

For Strand Wires

1. Use wire cutters to cut off the wire end and then peel away about 10mm of the insulation layer.
2. Use a screwdriver to unscrew the terminal screw on the terminal board.
3. Use a round terminal fastener or clamp to fix the round terminal firmly on the peeled wire end.
4. Locate the round terminal conduit. Use a screwdriver to replace it and tighten up the terminal screw (as shown to the right).

*To connect the thermostat wires and power cords, lead the thermostat wires and power cords through the insulation tube

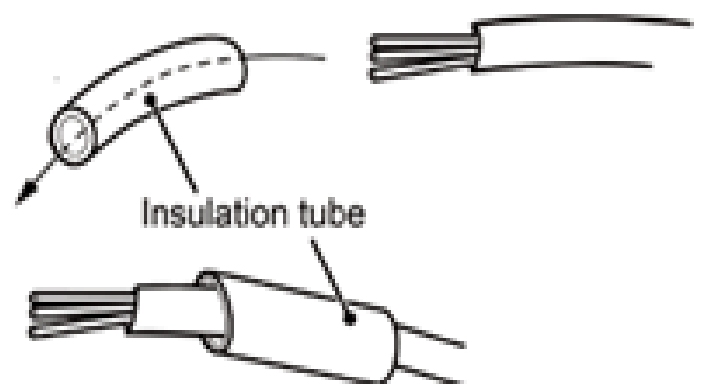

Vacuum Pumping

1. In order to prevent air, water, etc. from entering the refrigerant pipeline, use a vacuum pump to vacuum and dry the indoor side and the connecting pipe before charging the refrigerant.
2. Vacuum pumping should be done from both the high and low pressure sides of the unit, as shown in the figure below.
3. Keep the Inhalation Check Valve and Liquid Supply Check Valve closed when vacuuming.
4. Please use a Complex Gauge to confirm the pressure value.
5. After the vacuum reaches 1000 Microns, keep the pressure on for 2 hours. In that time, do not exceed 2000 Microns. If the pressure rises too quickly, it is necessary to repeat the vacuuming several times until the requirement is reached.
6. After vacuum pumping, fully open the Inhalation Check Valve and Liquid Supply Check Valve.



CAUTION: Vacuum Pumping is only required for Wall Mounted and Remote models

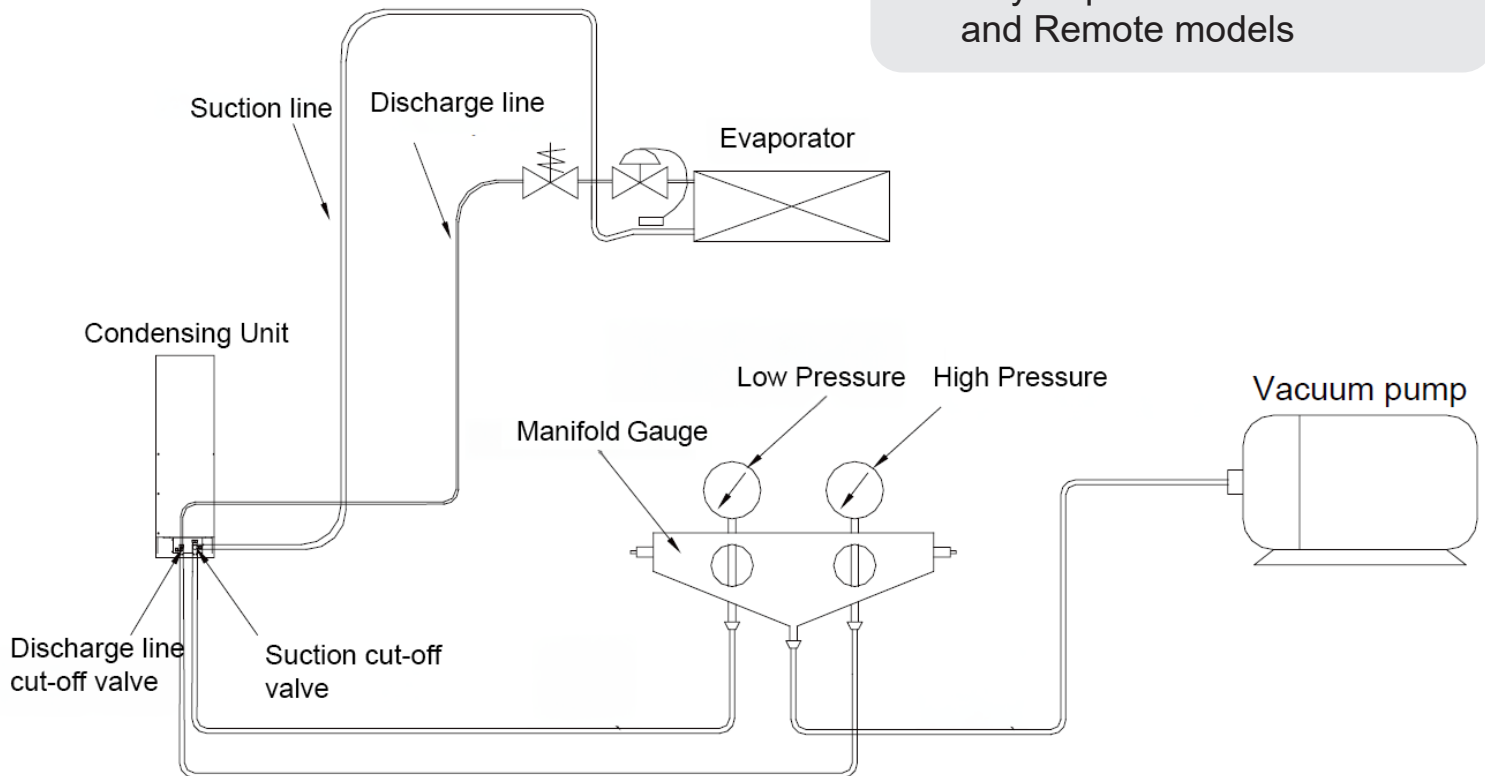

Charging of Refrigerant

1. After the unit air tightness and vacuum are checked to be qualified, the unit can be charged with refrigerant. Before charging, the refrigerant charging amount should be calculated according to the specific situation, or consult our company.
2. Taking into account the indoor unit and the charging part of the connecting pipe, it is necessary to supplement the refrigerant after starting up.
3. Start up the unit, slowly supplement it in gaseous form from the Refrigerant Injection Nozzle of the Inhalation Check Valve. (If conditions permit, it is best to supplement from the inlet of the evaporator to avoid damage to the compressor caused by the liquid in the refrigerant), as shown below:



CAUTION: The unit is fully charged with R404A from the factory. *DO NOT CHARGE* unless you are a trained professional.

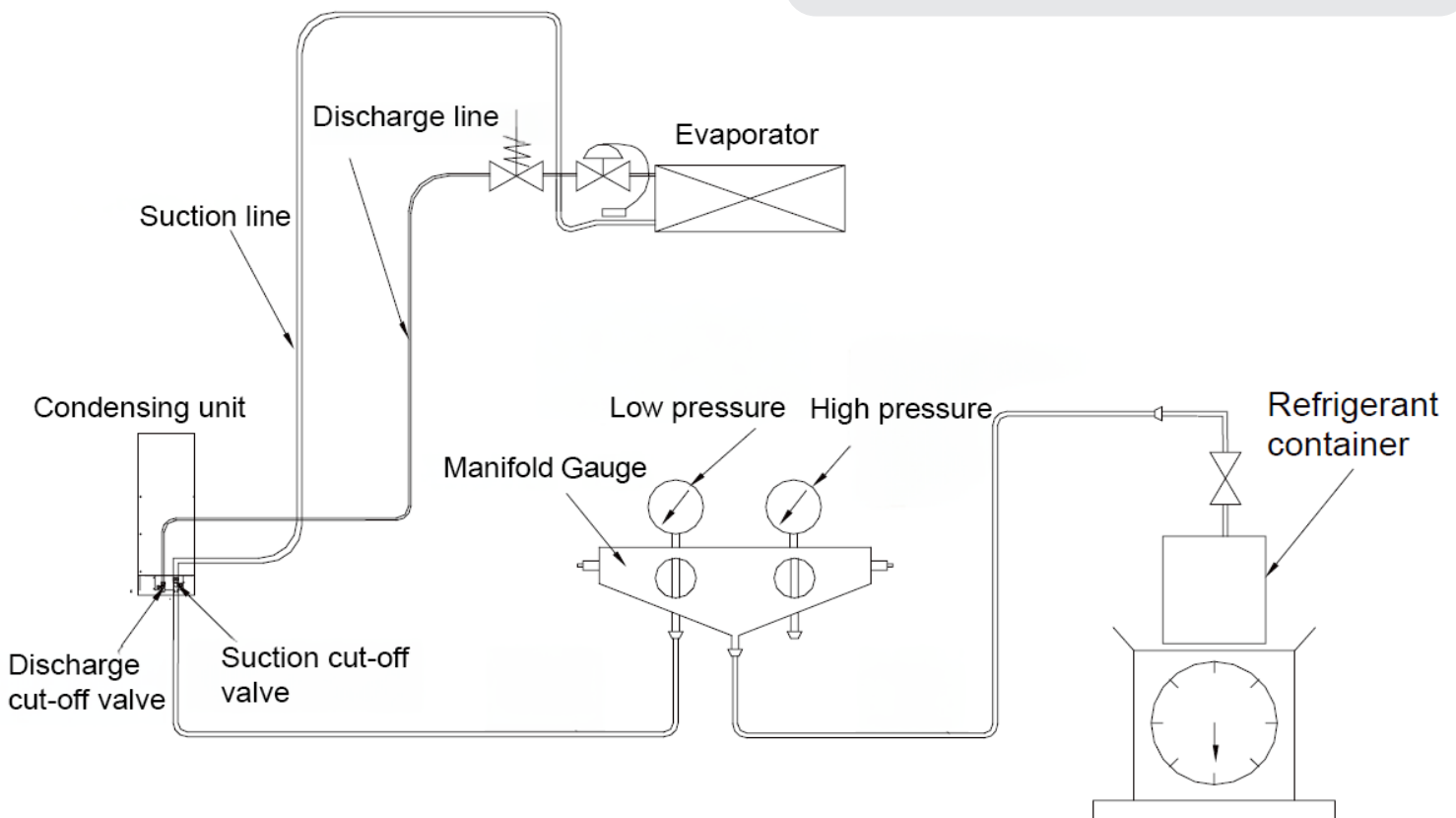

Installation of Refrigeration System

Part Preparation

Provided by factory (shown in figure below):

1. Discharge Line Tube
2. Suction Line Tube
3. Wire Harness (Labeled #1 & 2)
4. Wire Harness (Labeled #3 & 4)

Prepared by self:

- Adjustable Wrench
- 5mm and 8mm Hex Wrench
- Power Drill
- 5/8" Drill Bit
- Bubble Leak Detector
- Zip Ties

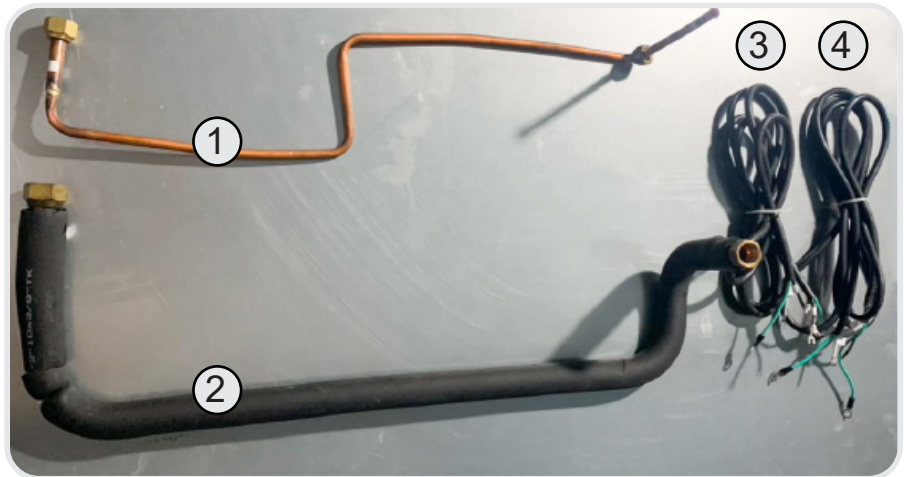

Spec Sheet for Condensing Unit

Task Completed	Date	Comment





CONDENSING UNIT

Model	ATW-R15V
Voltage/Phase	208V/230V/1
Rated Frequency	60Hz
FLA/HP of Outdoor Fan Motor	0.8A/0.2HP
Compressor RLA(R404A)	11.3A
Compressor LRA	24.0A
Minimum Circuit Ampacity	16.2A
Maximum Rating of Overcurrent Protective Device	25.0A
Design Pressure(High)	420 PSIG 2.9MPa
Design Pressure(Low)	320 PSIG 2.2MPa
Refrigerant (R404A)	8.8Lbs 4.0 kg
Moisture Protection	IPX4
Evaporator Temp	-16.6-32°F
Weight	81kg 179Lbs
Manufactured Date	YYYY.MM

Suitable for Outdoor Use
Adapté Pour L'usage Extérieur

This refrigeration system is designed and certified for use in walk-in cooler and walk-in freezer applications
USE COPPER SUPPLY WIRES.
UTILISER DES FILS D'ALIMENTATION EN CUIVRE.





CONDENSING UNIT

Model	ATW-R30V
Voltage/Phase	208V/230V/1
Rated Frequency	60Hz
FLA/HP of Outdoor Fan Motor	0.8A/0.2HP
Compressor RLA(R404A)	17.0A
Compressor LRA	40.0A
Minimum Circuit Ampacity	38.1A
Maximum Rating of Overcurrent Protective Device	40.0A
Design Pressure(High)	420 PSIG 2.9MPa
Design Pressure(Low)	320 PSIG 2.2MPa
Refrigerant (R404A)	11.0Lbs 5.0kg
Moisture Protection	IPX4
Evaporator Temp	-16.6-32°F
Weight	97kg 214Lbs
Manufactured Date	YYYY.MM

Suitable for Outdoor Use
Adapté Pour L'usage Extérieur

This refrigeration system is designed and certified for use in walk-in cooler and walk-in freezer applications
USE COPPER SUPPLY WIRES.
UTILISER DES FILS D'ALIMENTATION EN CUIVRE.



Installation of Ceiling

1. Place evaporating unit on ceiling of walk-in cabinet at right position and direction.



2. Install vent cover plate on the bottom of evaporating unit from inside walk-in cabinet. Pre-place condensing unit at close position on the ceiling of walk-in cabinet.



CAUTION: Do not install the screws now! Once Installation of the top part is completed, then install screws to secure the condensing unit to the ceiling.

Task Completed	Date	Comment

Connect Wires of Control Panel Box

1. Open the side cover of wire box.



2. Pass the 3 sets of signal wires (Cabinet Temperature Probe, Defrost Probe, Controller Wires) through the hole at the bottom of the box, and install the cover back on.



3. Open the black cover of the wire terminal board.

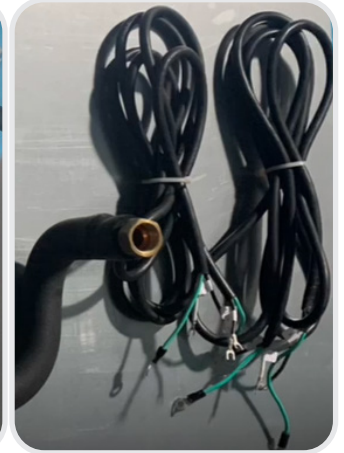

4. Connect 2 sets of wire harnesses (Labeled #1,2,4,5) to corresponding number on wire board, and connect ground wires to ground screws on the box. Install the cover back on in order to keep the 3 sets of signal wires and 2 sets of wire harnesses safe and clean.



Task Completed	Date	Comment

Connect Wires in Power Supply Box

1. Open the side cover of power supply box. Pass the 2 sets of wire harnesses through the hole at the bottom of box and install the cover back on.
2. Pass the wire harness (Labeled 24V) through the predrilled hole on the front ceiling panel) and connect later.



NOTE: 24V parts include LED, door frame heater, pressure relief heater, and temperature display. Keep 2 sets of wire harnesses (Labeled 230V and 24V) safe and clean.

Task Completed	Date	Comment

Power Supply Box(Large Size Unit)

For large Walk-in unit, there is a larger power supply box. The large power supply box has been divided into two parts. The two power supplies are prepared for door heater and LED use.



The power supply with red wires is for door heater. And the power supply with blue wires is for LED use. Please keep the correct wire connected to the specific items.

Pass both wire harnesses through the hole and connect later.

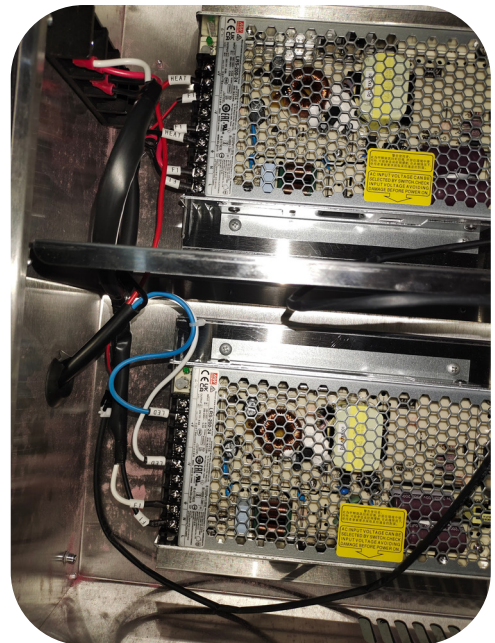
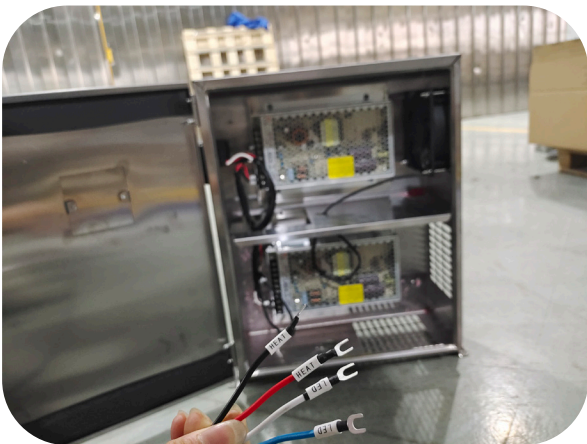

Wiring for Condensing Unit

1. Open the top panel by removing screws and lifting it up.



2. Open the front-side panel by removing two screws and pushing it down.



3. Pass the 3 sets of signal wires from previous section through the hole on condensing unit.



4. Connect these 3 sets of wires to the terminals numbers as labeled.

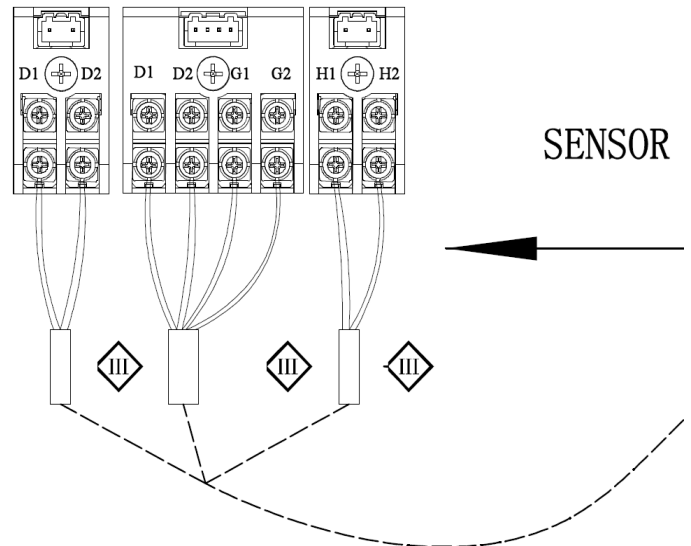
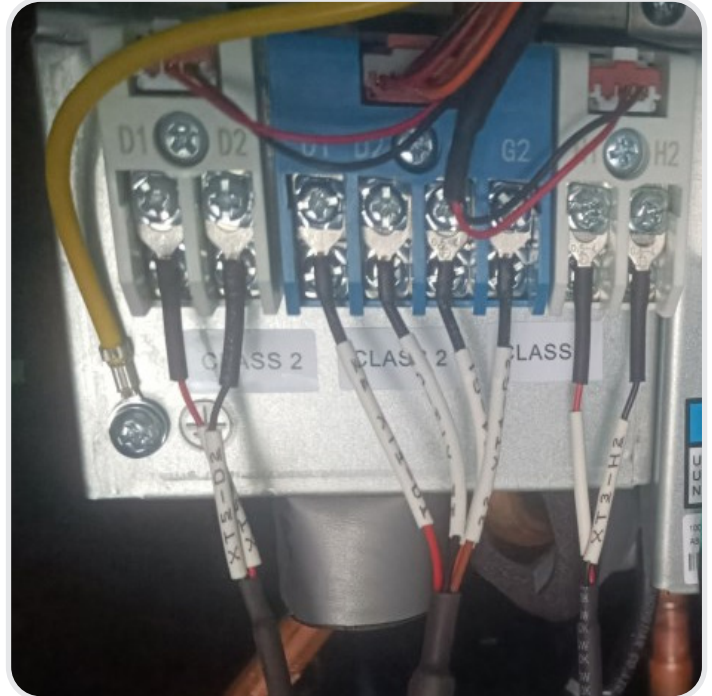

Task Completed	Date	Comment

Wiring for Condensing Unit

1. Pass the 2 sets of wire harnesses (from previous Step) through the hole on condensing unit.
2. Connect these 2 sets of wires to the terminals numbers as labeled.
3. Pass the wire harnesses through the hole on condensing unit.
4. Pass the Main Power Supply wires (power cord) through the hole on condensing unit.
5. Connect the wires to the L1 & L2 terminals as well as the Ground Connector.
6. Clean up and secure the wire harnesses with zip ties, then install panels back. Install screws to secure the condensing unit to the ceiling to complete.

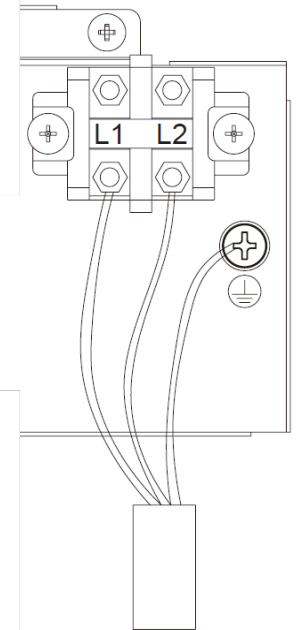
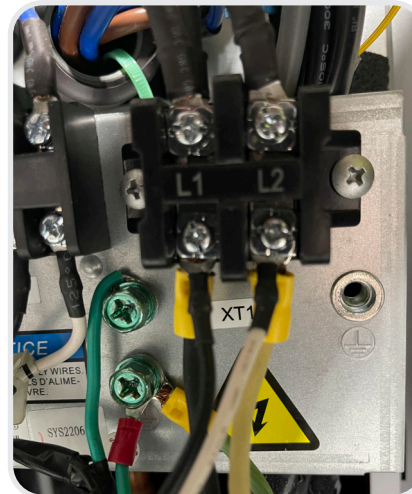
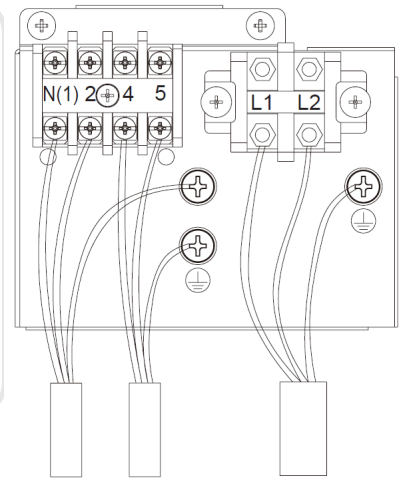
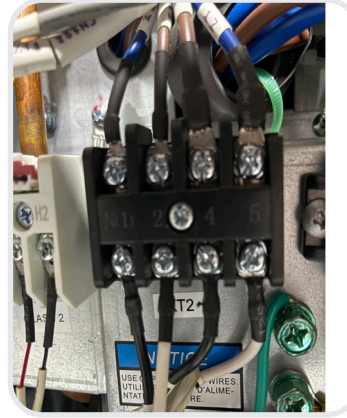

⚠ CAUTION: Main Power Supply wires (Power Cord) are NOT provided by the factory.

Task Completed	Date	Comment

Installation of Discharge line tube and Suction line tube (Evaporating Unit)

1. Remove protective caps on the valves of the Evaporating Unit.

⚠ CAUTION: Condensing and Evaporating units have been fully charged with refrigerant R404A from factory. There is no need to vacuum and charge in the field.



2. Connect tubes to valves. 5/8" tube is the Suction Line Tube with insulation outside, the side with "Label L2" is connected to the big valve; 3/8" tube is the Discharge Line Tube without insulation, and the side with "Label H2" is connected to the small valve. Both tubes are in the package provided by the factory.

3. Tighten connection nuts with wrench.



⚠ CAUTION: Check the Label on both sides of the tubes, connecting the correct side.



Task Completed	Date	Comment

Installation of Discharge line tube and Suction line tube (Condensing Unit)

1. Move and place the Condensing unit to correct position. Make sure both tubes can be installed properly.



2. Remove protective caps on the valves of the Condensing Unit.



3. Connect tubes to valves. 5/8" tube is the Suction Line Tube with insulation outside, the side with "Label L1" is connecting to big valve; 3/8" tube is the Discharge Line Tube without insulation, the side with "Label H1" is connecting to small valve.

4. Tighten connection nuts with wrench.



Task Completed	Date	Comment

Release air in the tube and Check for leaks

1. Remove the big cap on the Suction Line Valve of the condensing unit.
2. Remove the small cap on the Suction Line Valve of the Evaporating Unit.

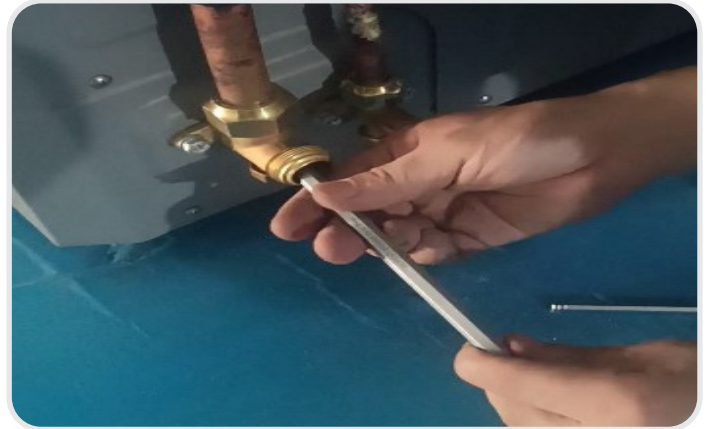

NOTE: 2 PEOPLE are required to complete this step within 2 seconds.

! WARNING: If release is more than 3 seconds, the refrigerant will be released to atmosphere, the installer should take action to recover the refrigerant according to Environment Protection Regulation.

3. Release air in the tube by pushing the pin inside on the valve on Evaporating Unit (one person), IN THE MEANTIME, the other person opens the valve on the Condensing Unit with 8mm Hex Wrench.



4. Install the caps back and Check leaks on both valves by bubble method.



Task Completed	Date	Comment

Release air in the tube and Check for leaks (Solution for Leak on Connection)

Solution A:
 Use wrench to tighten the nut more and check leak again, repeat it until no leaks.

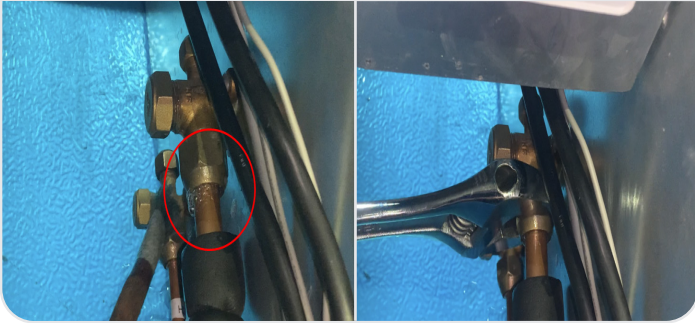

Solution B:
 If Solution A doesn't fix the leak, close the valve with a Hex Wrench. Recover the remaining refrigerant in the tube by authorized technician. Remove the leaking connection. Swage tube with Swage Tools and install it back. Repeat Steps above until no leaks.

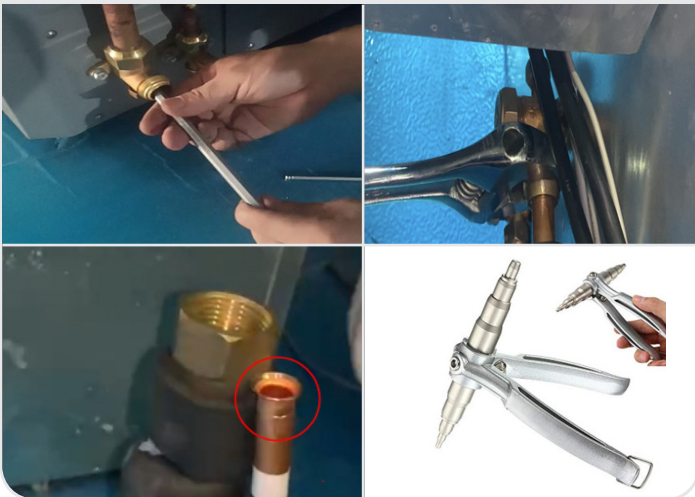

Release air in the Discharge Line Tube by repeating Steps with 5mm Hex Wrench. Confirm no more leaks on the valves and then fully open the valves on all 4 valves with Hex Wrench.

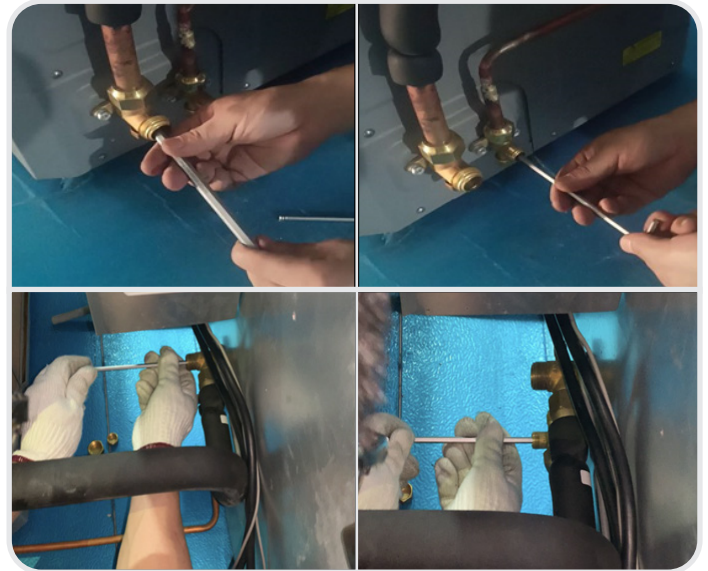

Clean up bubbles with dry cloth and install caps back. Add insulation foam on remaining Suction Line Tube and secure with Zip Ties.



Task Completed	Date	Comment

Wrap the Valve of the Low Pressure Tube

After installing the tubes, use rubber foam to wrap the two valves of Low Pressure Tube. Valves on both the condensing side and evaporating side need to be wrapped.

1. Wrap the valve with self-stick rubber foam longitudinally, and then wrap it transversely so that it is fully wrapped with the rubber foam in all directions.



2. Repeat the step above for the other side of the tube.

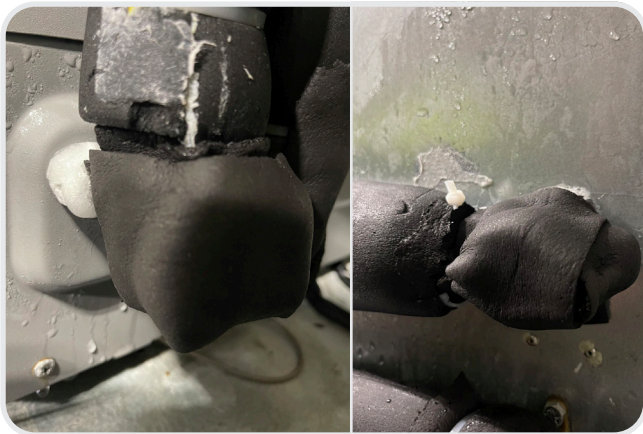

3. Check the Low Pressure Tube. Each end of the tube should be wrapped.



⚠ CAUTION: If the tubes are not properly wrapped, they will get frozen after the refrigeration process starts running.



Task Completed	Date	Comment

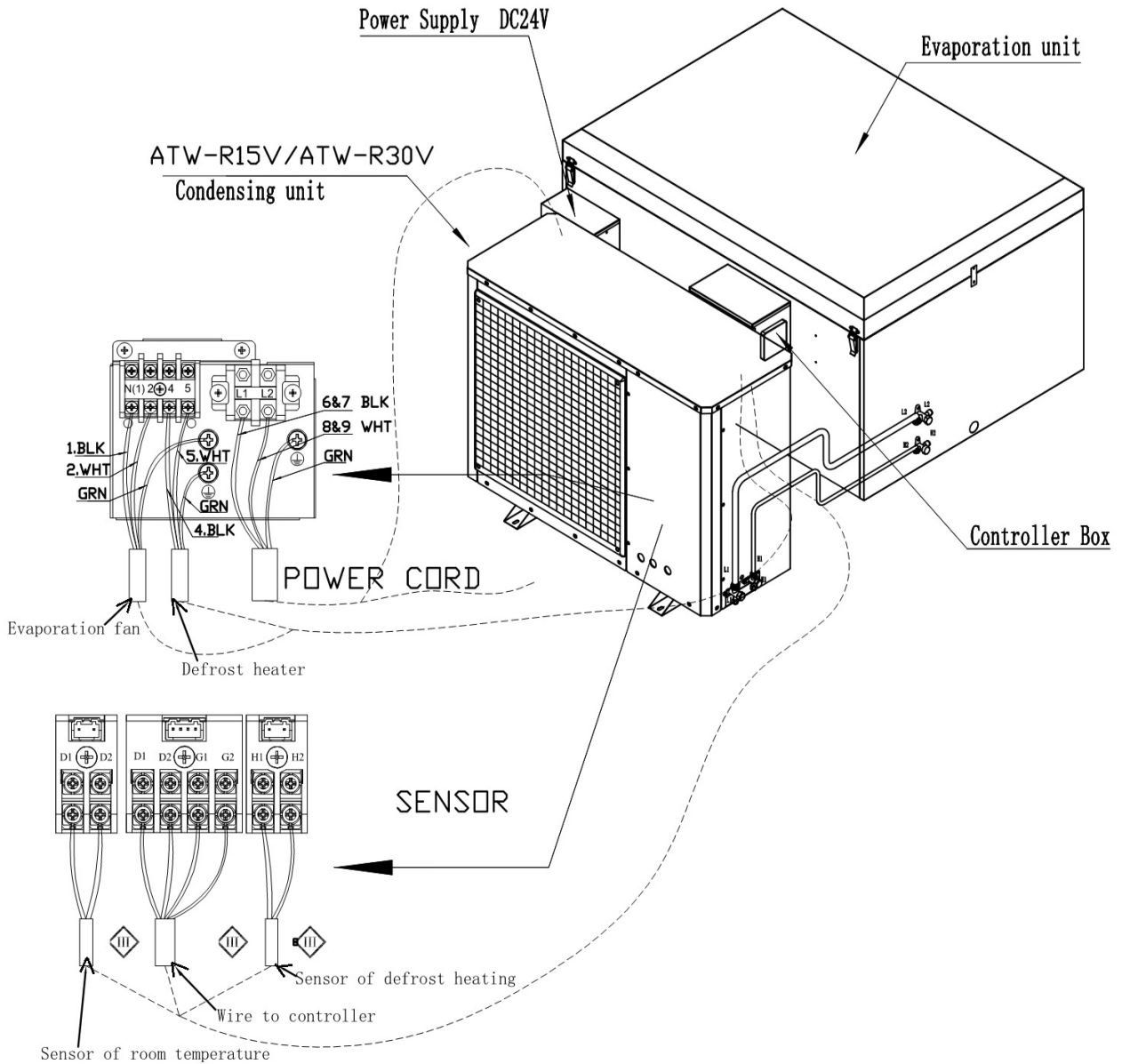

LED Installation

Drill a Hole

1. If the ceiling panel was installed the opposite way or there is no hole for wire harness, carefully drill a new hole above the box on the ceiling panel.



3. After the LED is installed, arrange the wire and bring the wire to the white wire box above the door. Make sure the wire can be attached to the wire box. Then cut the wire protector to fitting length. Attach one half of the wire protector on the ceiling. Push the wire inside and cover it with the other half of the wire protector.

Install LED

2. Open the box of LED. Find two metal clips which are used for holding the LED. Locate the center of the ceiling and screwing the two clamps in. Buckle the LED on the ceiling.



NOTE: We recommend the LED be installed in the center for better lighting.

Task Completed	Date	Comment

Connect wires in the cabinet for 24 DCV parts

1. Locate the White Wire Box at the top of the door. Open the box by removing screws, and pass the wire harness (from previous step) through the hole in the ceiling.
2. Connect the Black wire from LED to #3 connector with blue wire inside.
3. Connect the Red wire from LED to #4 connector with white wire inside.
4. Connect the Black wire from ceiling to the empty connection on #1 connector with black and white wire inside
5. Connect the White wire from ceiling to the empty connection on #2 connector with red and blue wire inside.

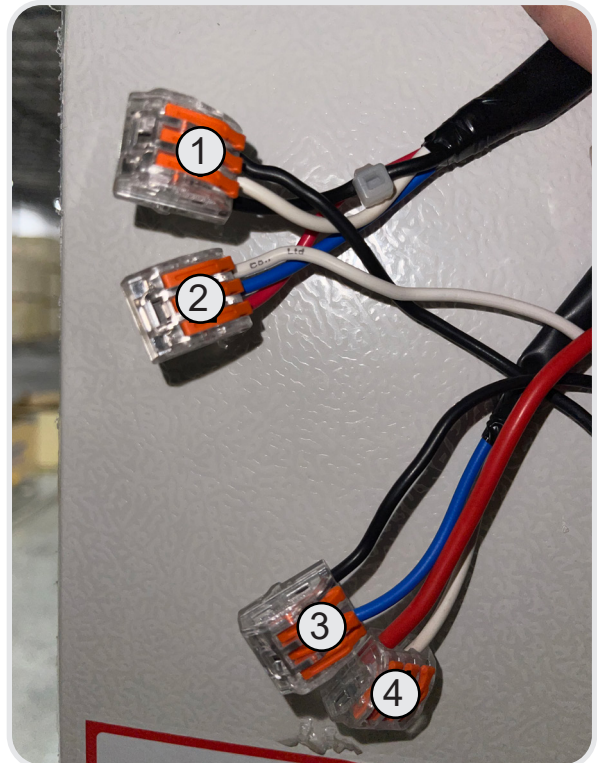
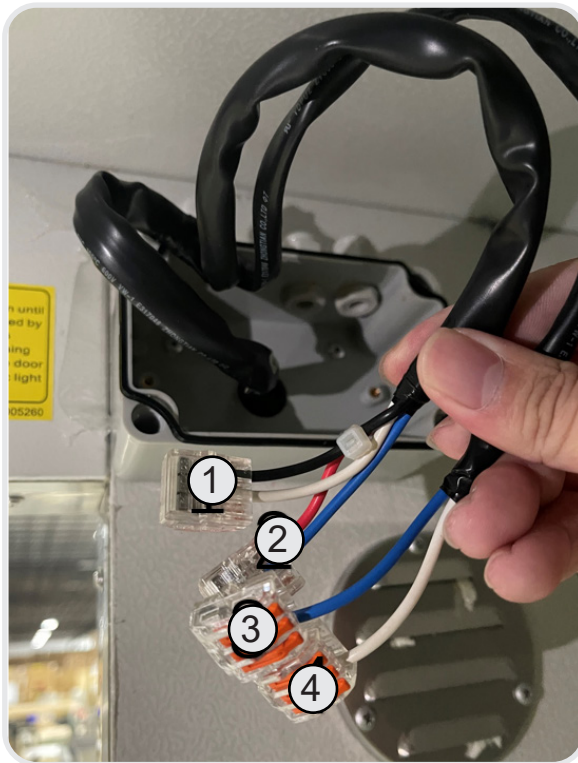

Factory Supplied

- Harness #1: Black wire + White wire
- Harness #2: Red wire + Blue wire
- Harness #3: Blue wire
- Harness #4: White wire

After Completion

- Harness #1: Black wire x 2 + White wire
- Harness #2: Red wire + Blue wire+White wire
- Harness #3: Blue wire + Black wire
- Harness #4: White wire + Red wire

Task Completed	Date	Comment

Install drain pipe from evaporating unit

1. Locate the Drain Pipe Connector at the bottom of the wire box on the evaporating unit.
2. Extend the pipe and lead it to Floor Drain/Drain exit.

NOTE: Sample unit with a short soft pipe.

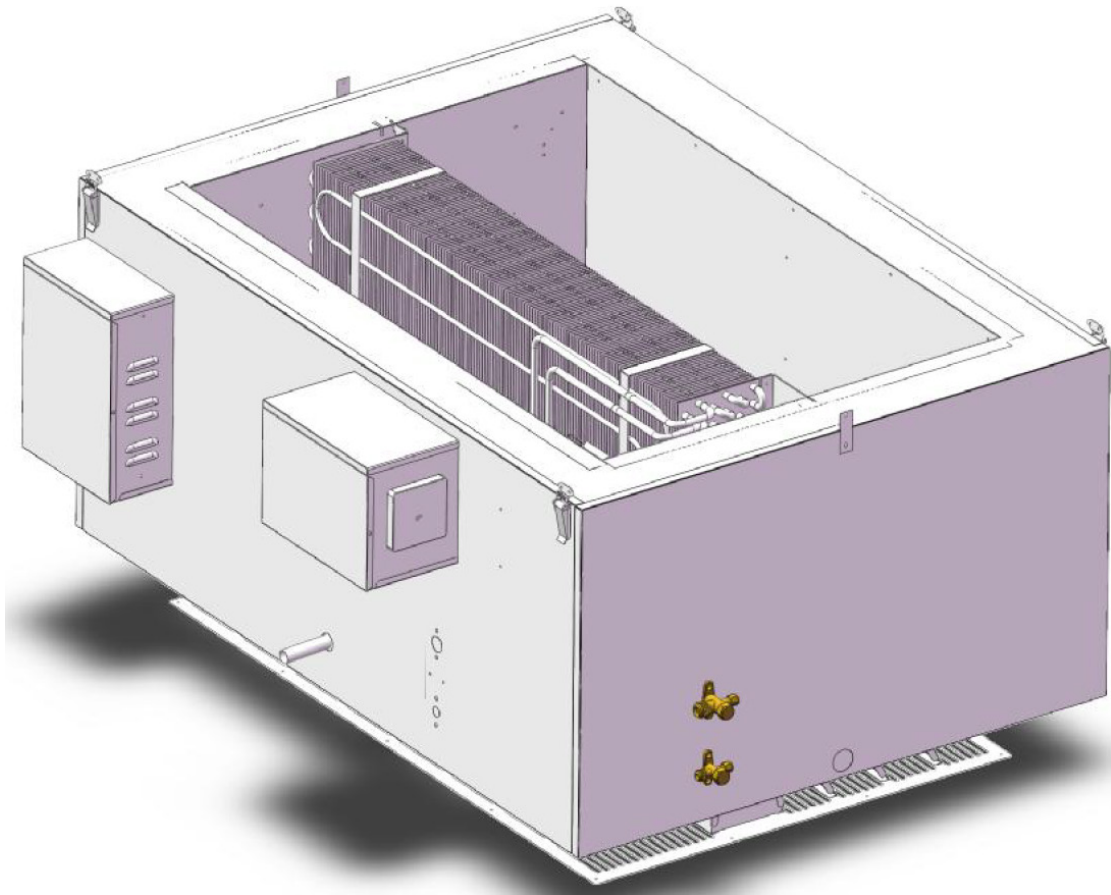

Task Completed	Date	Comment

Controller Setting

- 1. Unlock The Screen:**
Press “DOWN KEY + ON/OFF” for 3 seconds to unlock the controller if it is locked.
- 2. Set The Temperature Range:**
Press “SET/OK” for 3 seconds at the homepage to access to the user parameter settings page. Use “UP KEY” and “DOWN KEY” to switch to the desired parameter.
Use “UP KEY” and “DOWN KEY” to switch to the desired parameter.
- 3. Press “DOWN KEY + CHECK” for 3 seconds to access to the factory parameter settings page. Set the parameters following the chart on “Controller Parameters” page**

Check the Display of the LCD

For Cooler



For Freezer



Set “H000” for Start Temperature
Set “H001” for Stop Temperature

Code	Parameter	Comment	Freezer	Cooler
H000	Start Temperature	Compressor to run	-4	39
H001	Stop Temperature	Compressor to running	-10	33

NOTE: Read the subsequent procedures for more details.

⚠ Important: The condensing unit must have its parameters set before being turned on! Failure to do so will lead to severe damage!

Task Completed	Date	Comment

Controller Setting

LCD



LCD Icons

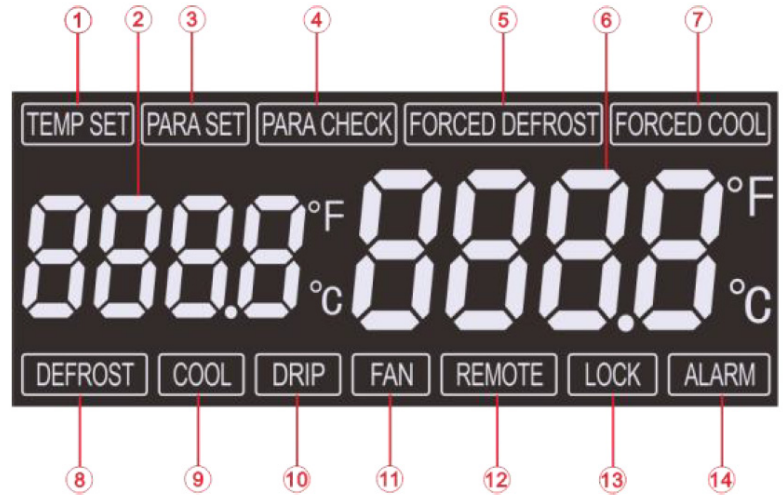

No.	Icon Name	Introduction
1	TEMP SET	Set the temperature status
2	PARAMETER CODE DISPLAY AREA	Display parameter code and display the set temperature or error code at the homepage
3	PARA SET	Set the parameter status
4	PARA CHECK	View the parameter status
5	FORCED DEFROST	Force to do defrosting
6	NUMERICAL DISPLAY AREA	Displays the status value of the parameter
7	FORCED COOL	Force to do cooling
8	DEFROST	Defrosting state
9	COOL	Cooling state
10	DRIP	Dripping state
11	FAN	Evaporator fan running state
12	REMOTE	Remote connection status
13	LOCK	Keyboard lock status
14	ALARM	Alarm status

Introduction to Buttons

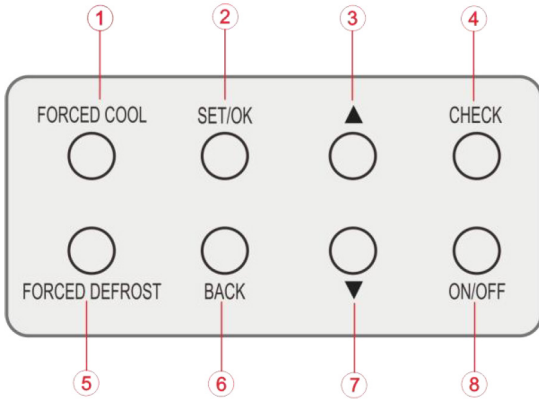

Parameter Setting

At the homepage, by pressing SET/OK button for long time, the controller will access to the user parameter settings page, as shown in Figure 4-8. Through UP KEY or DOWN KEY, it is able to select the desired parameter code and increase/decrease the setting value. When the parameter code is selected, the code will flash.



No.	Name	Description
1	Forced Cool	Under the ON status, press it at the homepage for 3 seconds to access or exit the forced cooling mode (invalid under the OFF status).
2	Set/Ok	Press it for 3 seconds at the homepage to access to the user parameter setting page.
3	Up Key	At the CHECK pages, it can switch to desired parameter. At the PARA SET pages, it can switch to the desired parameter and also increase or decrease the setting value.
7	Down Key	Note: by pressing it for long time, the controller will quickly perform switchover or modification.
4	Check	It is able to view parameters but cannot modify them.
5	Forced Defrost	Under the ON status, by pressing it for 3 seconds at the homepage, the unit will enter the or exit the forced defrosting (invalid under the OFF status). In the defrosting mode, hold on pressing the "FORCED DEFROST" button for 3 seconds to exit defrosting.
6	Back	By pressing it, the controller will back to the last menu. Under the alarm status, by pressing it, the alarm will not sound again but will still be displayed.
8	On/Off	Press it for 3 seconds to turn on or off the unit. Under the ON status, both the temperature set point and the cold storage temperature will be displayed. Under the OFF status, only the temperature set point will be displayed.

7+8	Down Key + On/Off	Lock operation (the press button operation will be locked when there is no any operation in 5 minutes.)
7+4	Down Key + Check	Press it for 3 seconds to access to the factory parameter settings page.
2+7	Set/Ok + Down Key	Press it for 3 seconds to access to the bar code page.
3+7	Up Key + Down Key	Press it for 3 seconds to access to the error settings page.
3+4	Up Key + Check	Press it for 3 seconds to access to the history error pages.

At the homepage, by pressing CHECK button and DOWN KEY for long time, the controller will access to the engineering parameter settings page, as shown in Figure 4-9. Through UP KEY or DOWN KEY, it is able to select the desired parameter code and increase/decrease the setting value. When the parameter code is selected, the code will flash.

Code	Parameter	Comment	Freezer	Cooler
H000	Start Temperature	Compressor to run	-4	39
H001	Stop Temperature	Compressor stop running	-10	33
L000	Defrost Termination Temperature	Defrost and temperature (0~99)	55	55
L001	T for Electric Frost Exit	Maximum time for Electric Frost	20	20
L002	ΔT : Temperature Difference	Difference between Room Temperature and Air Temperature	-	-
L003	Defrost Time or Temperature	01: Defrosting Time 02: Room Temperature before Defrosting	02	02
L004	Drip Time	Drainage Time after Defrost	5	5
L005	Shutdown Pressure for Pump-down	N/A	N/A	N/A
L006	Temperature Unit	01: °C 02: °F	02	02
L007	Address of the Remote Monitoring	N/A	N/A	N/A
L008	Refrigerant Type	01: R22 ; 02: R404A; 03:R410A 04: R448A; 05: R449A	04	04
L009	Defrost Mode	01: Interval Defrost; 02: No Defrost 03: Air Defrost	01	01
L010	Interval between Defrost Cycle	Defrost Time Interval (0~9 hr)	6h	4h
L011	Defrost Temperature Sensor	01: Exist 02: Not Exist	01	01
L012	Air Defrost Time	From 1 to 180 Mins	30	30
L013	Evaporating Fan Setting	01: Evaporating Fans Off during defrosting and when compressor off 02: Evaporating Fans off only during defrosting 03: Evaporating Fans Off during defrosting and when compressor off; Evaporating Fans delay after defrosting 04: Evaporating Fans off only during defrosting; Evaporating Fans delay after defrosting	04	04
L014	Display During Defrosting	01: Current Room Probe 02: Defrost Probe T	02	02
L015	Display T Delay	Real room temperature display (Unit: min)	10	10
L016	Condensing Unit Frequency	Unit: Hz	90	90
L017	Delayed Time for Restarting evaporating fan after defrosting	Unit: s	240	240

THANK YOU FOR YOUR PURCHASE OF
AN ATOSA PRODUCT

YOUR SINGLE SOURCE DIVERSIFIED GLOBAL SOLUTION



 Toll Free: (855) 855-0399

 info@atosausa.com

 www.atosausa.com

R10001001370

version number 20240725

