



# OPERATOR MANUAL

IMPORTANT INFORMATION, KEEP FOR OPERATOR

888-994-7636, fax 888-864-7636  
unifiedbrands.net

THIS MANUAL MUST BE RETAINED FOR FUTURE REFERENCE. READ, UNDERSTAND AND FOLLOW THE INSTRUCTIONS AND WARNINGS CONTAINED IN THIS MANUAL.

**FOR YOUR SAFETY** Do not store or use gasoline or other flammable vapors and liquids in the vicinity of this or any other appliance.

**NOTIFY CARRIER OF DAMAGE AT ONCE** It is the responsibility of the consignee to inspect the container upon receipt of same and to determine the possibility of any damage, including concealed damage. Avtec suggests that if you are suspicious of damage to make a notation on the delivery receipt. It will be the responsibility of the consignee to file a claim with the carrier. We recommend that you do so at once.

**Manufacture Service/Questions 888-994-7636.**

## EQUIPMENT DESCRIPTION

This manual covers three of the basic types of systems offered by Avtec:

### MODULAR GREASE EXTRACTORS SERIES

Extractor ventilators are listed by UL and are built in accordance of NFPA-96 for use with UL listed extinguishing systems for duct hood protection. These models utilize high velocity removable grease extractors. The canopy contains a hidden grease trough and removable cup. Surface, plenum and duct collar extinguishing systems may be factory supplied.

### ULTRAVIOLET (UV) SERIES

The EcoArch Energy Efficient Ventilation UVc is a door assembly integrally installed in the exhaust plenum of an EcoArch canopy, consisting of UVc filtration system designed for use in the ventilation control of commercial cooking operations of listed hood systems. A depiction of this unit is indicated at left.

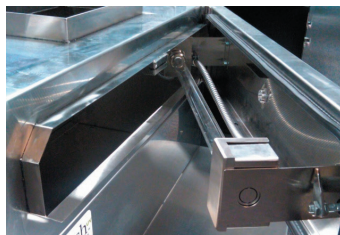

The UVc filtration system consists of a Heraus manufactured UVc and Ozone producing lamp used to reduce exhaust odors and grease deposit emissions before they enter the exhaust duct system. The UVc light waves and ozone producing lamp breaks the grease particles into smaller molecules which allow an Ozone reaction to occur chemically. Like combustion, high temperature separates the O-atoms in atmospheric Oxygen which then bonds to the grease molecule causing oxidation. Similarly, in UVc technology, the extra O-atom in the Ozone splits from the ozone molecule and attaches itself to grease molecule causing oxidation but without the high temperature, which results in the reduction of duct cleaning, cleaning costs and risks of potential grease fires.

This manual provides information for:

## ECOARCH ENERGY EFFICIENT VENTILATION SYSTEMS

### RETAIN THIS MANUAL FOR FUTURE REFERENCE

NOTICE: Due to a continuous program of product improvement, Avtec reserves the right to make changes in design and specifications without prior notice.

NOTICE: Please read the entire manual carefully before installation. If certain recommended procedures are not followed, warranty claims will be denied.

MODEL NUMBER \_\_\_\_\_

SERIAL NUMBER \_\_\_\_\_

INSTALLATION DATE \_\_\_\_\_

The EcoArch Energy Efficient Ventilation UVc is manufactured with Type 201 Stainless Steel; but, alternatively can be constructed using 200, 300 and 400 series stainless steel without adversely affecting the UVc filtration system capabilities.

### INSTALLATION INSTRUCTIONS

Avtec hoods are provided with adjustable hanging brackets designed to receive 1/2" threaded rod with a 1/2" nut and washer. Supporting rods must be connected to all factory supplied/installed brackets. Recommended hanging height is 78" - 80" above finished floor.

**ALL AVTEC VENTILATION SYSTEMS MUST BE INSTALLED IN ACCORDANCE WITH NFPA-96, REMOVAL OF SMOKE AND GREASE-LADEN VAPORS FROM COMMERCIAL COOKING EQUIPMENT.**

1. Check all local codes prior to installation. Special requirements may be necessary depending upon building material construction.
2. Move crated hood to location of installation and very carefully uncrate hood.
3. Raise hood to proper hanging height.
4. Suspend hood from adequate roof supports using 1/2" threaded rods with nuts and washers (See Fig. 1).
5. Level hood left to right and front to back.
6. Brackets are provided for hoods which are to be installed end to end or back to back.  
Bolt brackets together using 3/8" bolt through holes provided (See Fig. 2).
7. Install C channel where the ends of the hood meet and install T moldings on front face of hoods where they join. High temperature silicone can be used to install channel and T moldings (See Fig. 3).

## IMPORTANT - READ FIRST - IMPORTANT

**CAUTION:** DO NOT ATTEMPT TO SERVICE THIS UNIT YOURSELF AS REMOVING COVERS MAY CAUSE UNNECESSARY EXPOSURE TO DANGEROUS VOLTAGE.

**CAUTION:** NEVER CONNECT THE UNIT TO A POWER SOURCE WHILE STANDING IN WATER. WET HANDS AND WET FLOORS SHOULD BE AVOIDED WHEN CONNECTING ANY ELECTRICAL APPLIANCE TO A POWER OUTLET.

**CAUTION:** FANS MAY HAVE MULTIPLE POWER CONNECTIONS. MAKE SURE ALL FANS ARE ISOLATED FROM POWER PRIOR TO PERFORMING MAINTENANCE.

- For make-up air hoods, the supply collar with built-in UL listed damper and air volume damper must be installed per instructions on collar.
- Provide a removable service door in supply duct near damper (See Fig. 4).

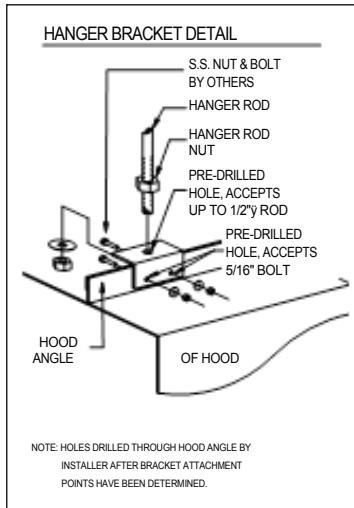

FIGURE 1

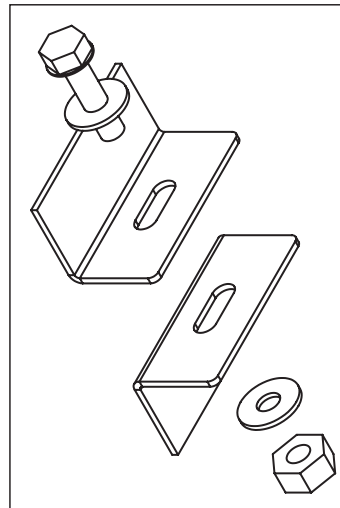

FIGURE 2

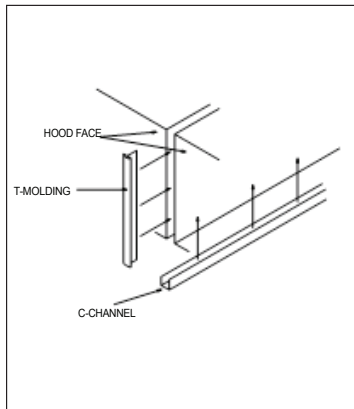

FIGURE 3

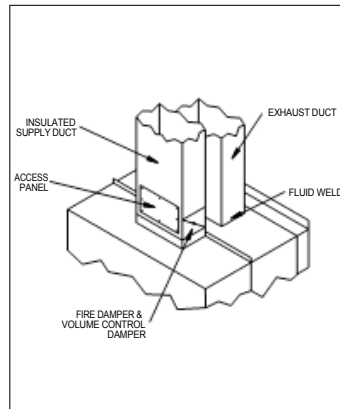

FIGURE 4

### ECOARCH CANOPIES EQUIPPED WITH UV ASSEMBLY

If your EcoArch hood comes equipped with an UV assembly please refer to the following steps.

General CAUTIONS & Guidelines:

- Installation of UV Exhaust canopies must be completed by HVAC ventilation system contractors or employees trained and qualified to do ventilation hood and exhaust system installation.
- All Fire Suppression System work must be completed by contractors or employees trained and qualified to do commercial kitchen exhaust hood fire suppression system installation.
- All work must conform to local and national building and NFPA 96 codes and requirements.
- This document covers installation of the UV mechanical components and electric connections.
- Electric work must be performed by licensed contractors in accordance with

the current National Electric Code and all national, regional and local codes that apply.

- Read and review these instructions BEFORE attempting to install this unit. For best results, follow the installation sequence...as described.

Follow steps 1-7 as outlined for standard EcoArch canopy installation under Installation Instructions previously provided.

- Install grease extractors as shown in (Fig. 5). Be certain the extractors are seated properly as the UVc bulb will not operate without safety contacts being engaged.
- Open door on face of canopy by twisting the supplied locking handle in order to install UVc bulb per supplied diagram. Be certain to close door tightly and engage handle latch in order to engage safety contacts. UVc bulb will not operate without safety contacts engaged.
- Check to see that pressure switch tubing is installed on the low port of switch and the port on top of the hood located in the s/s enclosure.
- Install power to UV system as described in Electrical section. See wiring diagram at end of this document.

### Modules (Figure 5)

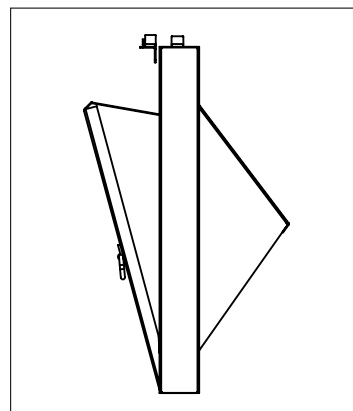

#### 3 MODULES

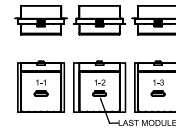

#### 4 MODULES

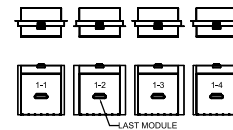

#### 5 MODULES

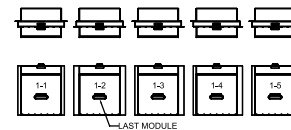

#### 6 MODULES

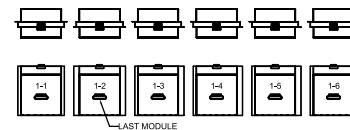

#### 7 MODULES

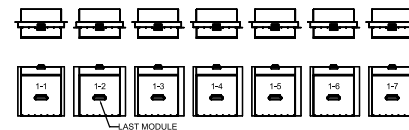

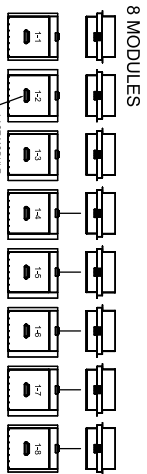

#### 8 MODULES

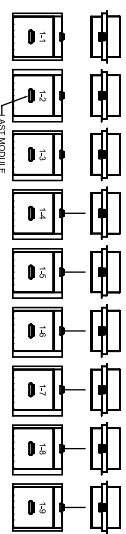

#### 10 MODULES

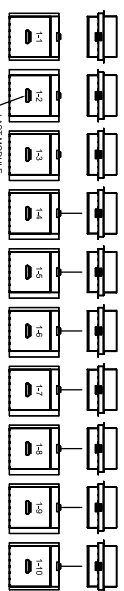

#### 11 MODULES

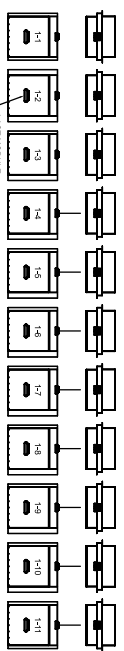

#### 12 MODULES

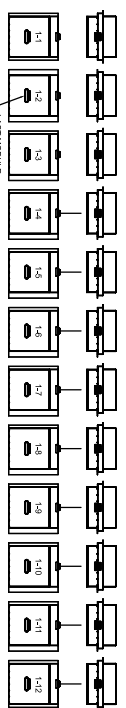

#### UV ELECTRICAL

**DANGER:** UV LIGHT BULBS GIVE OFF ULTRA VIOLET LIGHT WHICH CAN BURN YOUR EYES, ALWAYS USE CAUTION WHEN SERVICING THE UV SYSTEM.

**DANGER:** PLEASE USE CAUTION WHEN INSTALLING OR SERVICING THE ELECTRICAL SYSTEM FOR THE UV HOOD. ELECTRICAL SHOCK CAN CAUSE SERIOUS INJURY OR EVEN DEATH!!! ELECTRICAL WORK SHOULD ONLY BE DONE BY QUALIFIED PERSONNEL.

**CAUTION:** PLEASE ADHERE TO ALL ELECTRICAL NATIONAL, STATE, AND LOCAL CODES.

#### Install Power

Locate the relay box on top of the hood. Inside the relay box locate terminal strip 1 (TS-1). On terminal strip 1 connect a 115/60/1 – 20 amp service to terminals 1 and 2. THE 120V POWER SOURCE CONNECTED TO THE RELAY BOX IS FOR THE HOOD CONTROL SYSTEM AND UV LIGHTS ONLY. THIS POWER SOURCE IS NOT FOR THE CANOPY LIGHTS OR FANS. Those systems require separate power sources.

#### Control Panel

The control panel will be mounted on the hood or remotely. If the control panel is mounted on the hood no installation is required. If the control panel is located remotely then installation is required.

#### Remote Located Control

- Locate terminal strip 2 (TS-2) in relay box located on top of the hood. This is where the UV light switch will terminate. THE POWER AT (TS-2) IS 115V/1/60. Connect one side of the switch to terminal 1 and the other side of the switch to terminal 2. Please make sure the switch is connected to ground.

#### EXHAUST FAN & DUCT

- Check all local codes prior to installation.
- All exhaust fans are supplied with a hinge kit and grease box.
- The exhaust fan curb should be installed directly above the hood if possible. Always maintain the shortest duct run possible.
- Cut hole and seal exhaust fan curb to roof.

- Duct shall be sized to provide air velocities with a target of 1500-1700 FPM.
- Install hinges and airline cable on exhaust fan cap and metal curb. Remember to leave ample room for fan to tilt back. Fan will remain in tilted back position.
- Install grease collection box on side of fan that has grease tube discharge.
- The exhaust duct must be constructed of 16 gauge carbon steel or 18 gauge stainless steel. All seams must be fluid welded.
- A duct transition should be provided below exhaust fan inlet.
- The exhaust duct must be fluid welded to hood collar.
- Make all necessary electrical connections and check fan for proper rotation.

NOTE: Fan will exhaust air running in wrong direction.

#### CONTROL PANEL

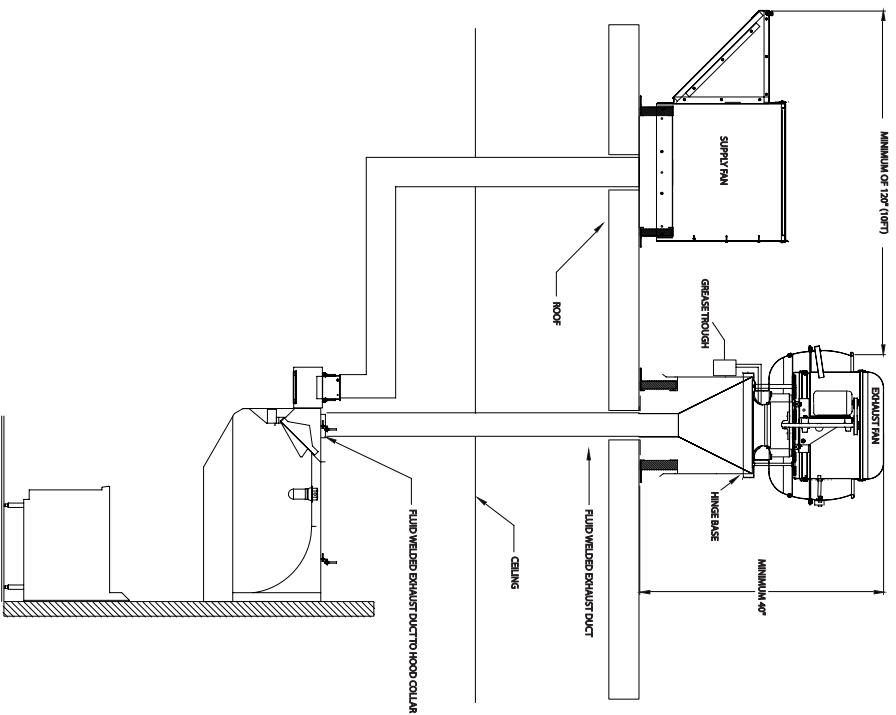

#### Wall Attachment

Control panels optional with all baffle filter type and modular grease extractors.

Control panel dimensions and connection detail are shown on the enclosed shop drawing. Panels may be surfaced mounted, partially recessed or fully recessed.

#### Surface Mounted

Drill four holes in ventilator plumbing compartment as required. Be careful not to damage any components. Avoid drilling into electrical compartments. Bolt to wall with anchor bolts or other acceptable means. Weight of control panel varies from 90 to 200 lbs.

#### Recessed Mounted

Cut hole in wall 1/2" greater than overall dimensions of the control box (shown on shop drawing). Spacers or support angles may be necessary to provide proper support. It is recommended that the panel be bolted to wall similar to method used for surface mounted above.

## Fresh Air Supply Fan

1. Check all local codes prior to installation.
2. Supply fan inlet must be located to minimum 10'-0" from the exhaust fan. If 10' is not possible a 3' vertical separation may\* be acceptable.
3. Cut and seal supply fan curb to roof.
4. Duct shall be constructed of 22 or 24 gauge steel. Insulated duct material should be used to eliminate frost and/or condensation.
5. Duct shall be sized to provide air velocities not exceeding 1200 FPM.
6. A volume control damper, provided in the duct just above the supply collar that contains the UL listed fire damper, should be properly set to supply CFM required.
7. If the hood is provided without the supply collar installed, it must be installed per the instructions provided on the collar.
8. Carefully place the supply fan on roof curb. Face supply fan inlet away from prevailing winter wind. Electrical back draft damper is recommended in cold climates.
9. Bolt or screw fan to fan curb.
10. Make all necessary electrical connections and check fan for proper rotation.

NOTE: Fan will supply air running in wrong direction. \*Dependent on local code requirements.

## SIDE SKIRTS

Skirts are provided for open ends and are required for UL Listings. Install skirts after cooking equipment is in place under the hood.

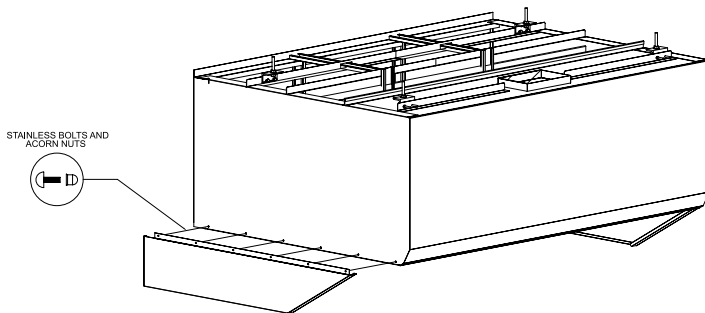

1. Side skirts are offset at the top and have a 90° bend inward at the rear.
2. Skirts are to overlap the outside of the hood. Bolts and acorn nuts should be attached per the drawing (stainless bolts and acorn nuts supplied).
3. Skirt flange should be screwed to the wall (screws not provided).

## TOP ENCLOSURES

Enclosure panels are provided for exposed side(s) of hood(s).

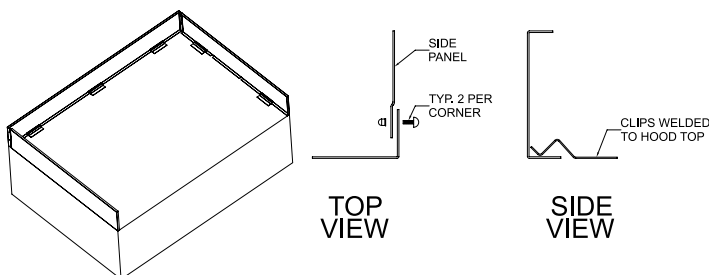

1. Hoods ordered with enclosure panels will be shipped with clips installed on perimeter of hood top where panels are to be installed.
2. Slide enclosure panel under clips.
3. If enclosure panels are installed on one or more hoods butted end to end, the butting ends of the front enclosure panels should be bolted together.

## INSULATED WALL PANEL

Insulated wall panel comes in multiple pieces.

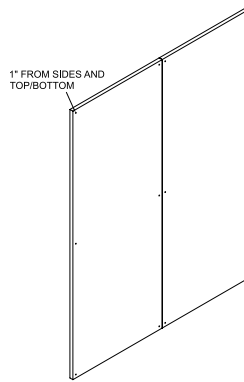

1. Install wall panels prior to hanging hood(s).
2. Install first panel at one end. Check hood hanging height, typically 78"-80". Top of panel should be installed at the hood hanging height A.F.F. and level. Screw panel to wall.
3. Install any additional panels
4. Caulk vertical seam with NSF approved silicone sealant.
5. When hood is hung it will rest on top panel.

NOTE: Be careful to not damage wall panel face when installing hood.

## SINGLE THICKNESS WALL PANEL

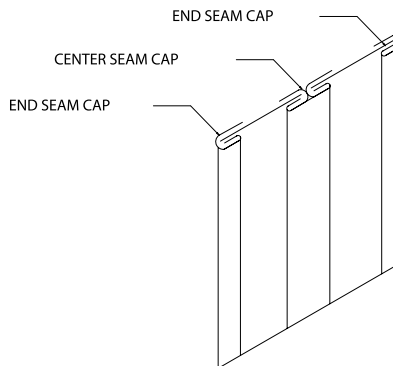

1. Install wall panels prior to hanging hood(s).
2. Install seam strips at proper locations and screw to wall.
3. Apply glue to wall between seam strips.
4. Slip one end of wall panel into seam strip, pull out middle of panel and slip other end of panel into other seam strip. Gently apply pressure over entire wall panel to secure to wall. Wall bands for side walls are provide with 1" return bend, which is to be located behind rear wall panels.

## START/CHECK/BALANCE

### DIRECT DRAW HOODS

1. Close all doors and windows.
2. Operate all exhaust fans, even fans serving other hoods, make-up air units and building HVAC.
3. Turn on all cooking equipment under the hood to preheat to operating temperature.
4. Produce large quantities of smoke.
5. Observe capture of vapors.
6. If all vapors are not captured, increase exhaust fan RPM.
7. Check air pressure in kitchen. Pressure must be negative relative to dining room pressure.
8. Air velocities entering the kitchen from the dining room should not exceed 100 FPM. No air should be moving toward the dining area.
9. Repeat steps 6 and 7 until all vapors are captured.
10. Same as step 7 with bottom of next section.

NOTE: The exhaust and supply (if any) air flow rates were established under controlled laboratory conditions, and greater exhaust and/or lesser supply air may be required for complete vapor and smoke removal in specific installations.

### MAKE-UP AIR HOODS EXHAUST FAN(S)

1. Open all doors and/or windows leading to outside.
2. Start the exhaust fan only. Do not run the supply fan or make-up unit.
3. Refer to drawings and/or UL information label on hood for proper CFM requirements.
4. Adjust speed of exhaust fan to obtain proper air velocities and CFM through grease filters.

### Final Balance

1. Close all doors and windows.
2. Operate all exhaust fans even those serving other hoods, supply fans, make-up air unit and building HVAC system.
3. Turn on all cooking equipment under the hood and preheat to operating temperature.
4. Produce large quantities of smoke or steam.
5. Observe capture of vapors.
6. If all vapors are not totally captured, fine tune the system by adjusting the air volume control damper installed in the supply collar. Slightly reduce the amount of supply air directed under the hood until full capture is obtained.

### SUPPLY FAN OR MAKE-UP AIR UNIT

1. Start the supply fan and/or make-up unit only. Do not run the exhaust fan.
2. Refer to drawings or UL information label on hood for proper CFM requirements.

## PERIODIC MAINTENANCE

**WARNING:** ELECTRICAL SHOCK HAZARD! DISCONNECT POWER BEFORE SERVICING. REPLACE ALL PARTS AND PANELS BEFORE OPERATING. FAILURE TO DO SO CAN RESULT IN DEATH OR ELECTRICAL SHOCK.

**CAUTION:** MAKE SURE ALL COOKING EQUIPMENT, THE EXHAUST HOOD AND UVC EXHAUST AIR CLEANER HAVE BEEN TURNED OFF AND ALLOWED TO COOL. HOT EQUIPMENT CAN CAUSE BURNS.

**CAUTION:** USE STEP LADDER OR OTHER STABLE PLATFORM TO PROVIDE EASY ACCESS TO THE INTERIOR OR THE UVC LAMP CABINET. DO NOT STAND ON COOKING EQUIPMENT TO SERVICE THE UVC. FALLS CAN CAUSE SERIOUS INJURIES.

### MODULAR GREASE EXTRACTORS

Modules should be removed and cleaned at least weekly, depending on hours of operation. Modules may be cleaned with a brush and a strong detergent solution or run thru the dishwasher. When replacing modules, make sure they are seated properly.

### GREASE TROUGH

Should be checked weekly for grease build up and cleaned with strong detergent if necessary.

### GREASE COLLECTION RECEPTACLE

Should be emptied at least once a day and cleaned daily with a strong detergent.

### HOOD CANOPY

Inside hood canopy should be wiped down as needed. The area at the exhaust intake openings should be wiped down daily.

Inspect inside of extraction chamber at least weekly to insure proper cleaning and that the trough and access door are free of foreign matter.

### UV PREVENTATIVE MAINTENANCE

Clean the UV lamp at the same time the grease extractors are being cleaned (or daily), wipe down the UV lamp exterior using a dry towel and a non-detergent cleaning agent such as sanitizing solution or white vinegar.

**IMPORTANT:** Do not allow cleaner to run into lamp fittings or socket enclosures.

**IMPORTANT:** UV System will not work properly without daily cleaning of the UV lamp.

CALL FACTORY FOR REPLACEMENT PARTS:  
888-994-7636

# Parts List

ITEM	SERVICE PART	DESCRIPTION
<b>ECOARCH</b>		
1	HD HDL010	4" Chrome Handle
2	AS SEAL395	3/8" Quickseal
3	<a href="#">AS GLB0201</a>	Incandescent Work Light Globe
4	<a href="#">AS FIX0201</a>	Incandescent Work Light Cage
5	<a href="#">AS LGT1220</a>	3'-0" Fluorescent Work Light
6	<a href="#">AS LGT1420</a>	4'-0" Fluorescent Work Light
7	AS LGT1020	2'-0" Fluorescent Work Light
8	AS LGT9901	Recessed Incandescent Work Light
<b>UV</b>		
1	AS SEAL1001	Sight Glass
2	<a href="#">EL BLS1101</a>	Ballast, UVC Lamp, 115V
3	<a href="#">EL CNT1104</a>	Connector, UV Lamp
4	<a href="#">EL CON1001</a>	Magnetic Contacts
5	EL FUS0205	1 amp Fuse
6	<a href="#">EL FUS0307</a>	10 amp Fuse
7	EL FUS1101	3 amp Fuse
8	EL GRM1101	Grommet, UV Lamp Socket Heat Resistant
9	EL RLY0327	IDEC Base
10	<a href="#">EL RLY0801</a>	24V IDEC Relay SPDT
11	<a href="#">EL SCK1101</a>	Socket, UV Lamp
12	EL SCK1102	Socket Retaining Nut, UV Lamp
13	EL SWT1001	Door Safety Switch
14	<a href="#">EL SWT1003</a>	Airflow Proving Switch
15	<a href="#">EL TRN0304</a>	24V Transformer
16	<a href="#">EL TUB1101</a>	Lamp, 150W UV
17	HD HDL0601	Locking Door Handle
18	HD HIN2078	Hinge
19	IN GSK1105	Gasket, UV Door



# Wiring Diagram

## RELAY BOX

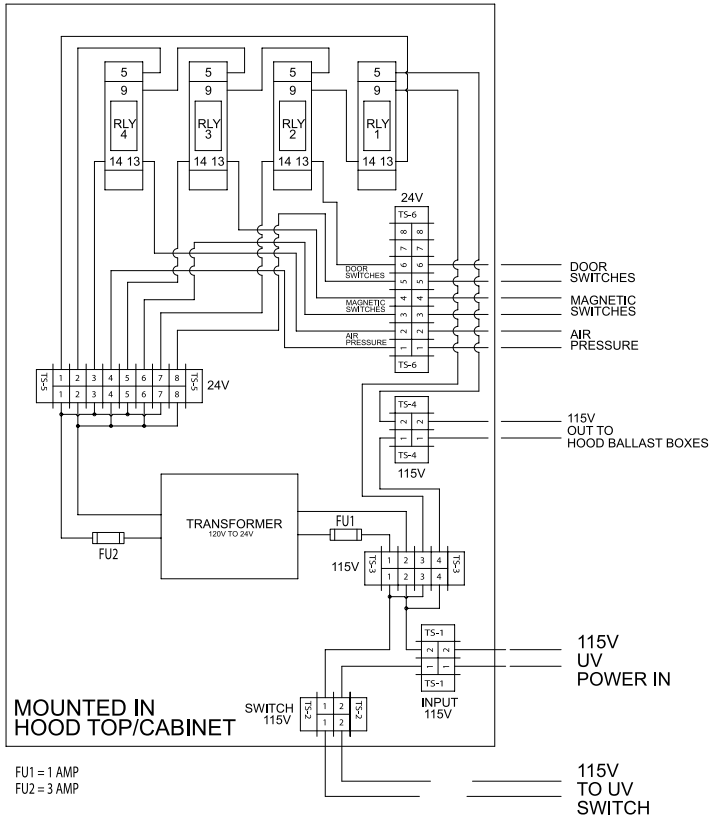

## HOOD #1

