



Operator & Installation Manual



MB100 PROOFER/HOLDING CABINET MB300 PROOFER

Model Number: _____

Serial Number: _____

Date of Installation: _____

TABLE OF CONTENTS

GENERAL	3
INSTALLATION	3
Assembly	3
Unpacking.....	3
Plumbing Connections.....	4
Drain Connections	4
Electrical Connections	4
Dimensions and Service Connection Diagram	5
OPERATION.....	6
Proofing	6
Temperature	7
Humidity.....	8
Setting the Timer	9
Starting/Adjusting the Timer	9
Canceling/Stopping the Timer	9
Proofing Instructions.....	10
Holding Instructions (MB100 Only).....	10
Shutdown Procedures	10
CLEANING	11
MAINTENANCE	12
Service and Parts Information	12
TROUBLESHOOTING	13
PARAMETER SET-UP MODE.....	14

OPERATION AND CARE OF MB100/MB300 PROOFER

SAVE THESE INSTRUCTIONS

GENERAL

The MB100/MB300 Proofer cabinet proofs racks of dough product under controlled temperatures and humidity prior to baking. The MB300 Proofer has a 16-pan capacity that accommodates 18" x 26" (45.7 cm x 66 cm) baking trays with 3" (7.6 cm) slide spacing. The MB100 holds 8 pans and can be used as a holding cabinet. Temperature and humidity can be set independently to meet your particular proofing needs. Air is circulated continuously to provide positive movement from bottom to top, creating a uniform distribution of warm, moist air.

All MB100/MB300 Proofers have easy-to-clean stainless steel interior and exterior panels with urethane foam insulation.

The MB100/MB300 Proofers are produced with quality workmanship and material. Proper installation, usage and maintenance of the proofer will result in years of satisfactory performance.

It is suggested that you thoroughly read this manual and carefully follow the instructions provided.

INSTALLATION

The MB100/MB300 Proofer must be installed by authorized Bakery Systems trained service technicians.

ASSEMBLY

The proofer comes pre-assembled, but requires qualified personnel to install and make connections. The proofer must be installed with restraining means to guard against transmission of strain to the connector, as specified by the manufacturer. Adequate means must be provided to limit the movement of the appliance.

UNPACKING

This proofer was inspected before leaving the factory. The transportation company assumes full responsibility for safe delivery upon acceptance of the shipment. Immediately after unpacking, check for possible shipping damage. If the proofer is found to be damaged, save the packaging material and contact the carrier within 15 days of delivery.

Carefully unpack the proofer and place in a work-accessible area as near to its final installed position as possible. Remove protective covering from exterior surfaces prior to placing proofer in final location.

PLUMBING CONNECTIONS

Water and waste piping and connections shall comply with the International Plumbing Code 2003, International Code Council (ICC), or to the Uniform Plumbing Code 2003, International Association of Plumbing and Mechanical Officials (IAPMO).

⚠ WARNING Plumbing connections must comply with applicable sanitary, safety and plumbing codes and provide adequate backflow protection to comply with applicable federal, state and local codes.

The proofer should have its own water supply line, separate from the oven.

The proofer water supply should have a hardness of 4 to 6 grains per gallon, pH of 6.5 to 8.0 and chlorides less than 30 PPM. Water condition outside of these requirements may void the warranty. Please consult your local water company and/or water condition dealer before installing proofer.

Connect the cold water supply to the 1/4" NPT incoming water connection located at the rear of the proofer. Water supply should have a pressure of 30 to 75 psi.

DRAIN CONNECTIONS

Connect a 1/2" drain line to the 1/2" NPT drain connection on the MB300 (3/8" NPT drain connection on the MB100) located at the rear of the proofer. Route the drain line to a floor drain, allowing a minimum 1" air gap between the drain line outlet and floor drain.

ELECTRICAL CONNECTIONS

⚠ WARNING Electrical and grounding connections must comply with the applicable portions of the national electrical code and/or other local electrical codes.

⚠ WARNING Disconnect the electrical power to the unit and follow lockout / tagout procedures.

⚠ WARNING Appliances equipped with a flexible electric supply cord are provided with a three-prong grounding plug. This plug must be connected into a properly grounded three-prong receptacle. If the receptacle is not the proper grounding type, contact an electrician. Do not remove the grounding prong from this plug.

DIMENSIONS AND SERVICE CONNECTION DIAGRAM

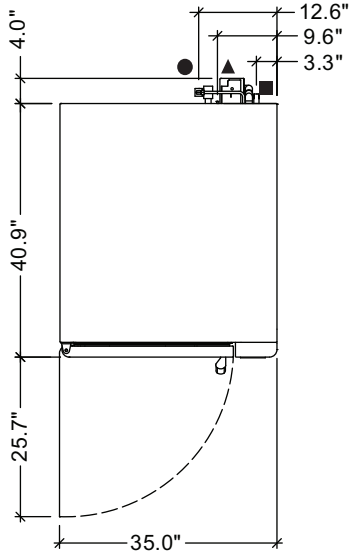

Service Connection Points

- Power ▲
- Water ●
- Proofer Drain ■

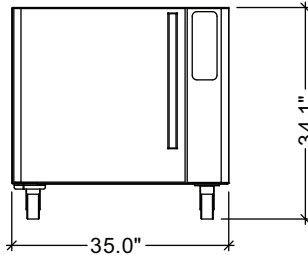

Electrical Data	
Volts	120
Hertz	60
Amps	15
Phase	1

Dedicated 20 A circuit breaker and outlet required.

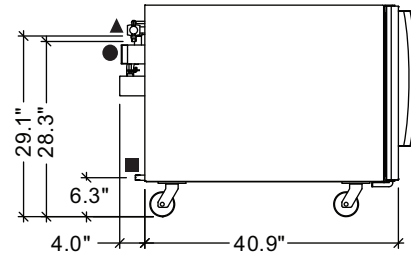

MB100 Proofer/Holding Cabinet

Electrical Data	
Volts	120
Hertz	60
Amps	13
Phase	1

Dedicated 20 A circuit breaker and outlet required.

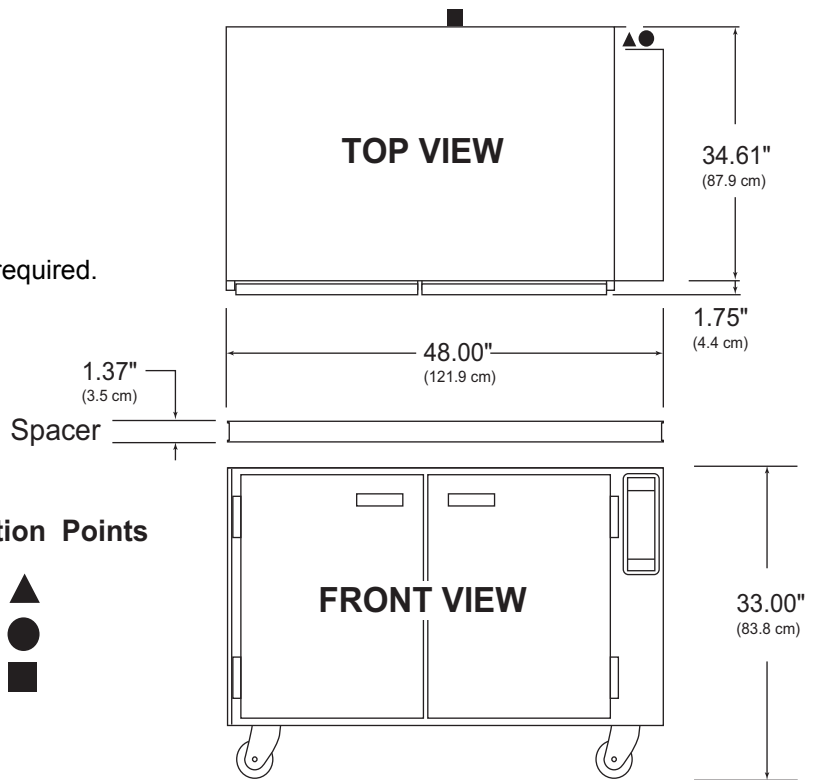

Service Connection Points

- Power ▲
- Water ●
- Proofer Drain ■

PL-58303

MB300 Proofer

OPERATION

PROOFING

Controlled temperature and humidity in the proofer promotes yeast fermentation, which generates gas and causes the dough to rise. Proofing takes from 45 to 60 minutes, depending on the product. A temperature setting of 95°F (35°C) and humidity at 85% are typical but will vary slightly, depending on the product being proofed. To dry-proof, set the humidity to the lowest setting.

CONTROLS

TEMPERATURE WINDOW - Displays the current or set temperature. The LED dot will be lit when the heat cycle is running. The maximum setting is 115°F (46°C).

HUMIDITY WINDOW - Displays the current or set humidity. The LED dot will be lit when water is being injected into the proofer cavity.

TIMER WINDOW - Displays the current or set timer. The LED dot will flash to indicate the timer is running.

TIMERS ARROW BUTTON - Press to select a timer (1, 2 or 3). The indicator above the number will be lit to show which timer is in use.

TEMP BUTTON - Press to adjust or set the temperature. When the button indicator is lit, the temperature displayed is the set temperature. When the button indicator is not lit, the temperature displayed is the current cavity temperature or set temperature.

HUMIDITY BUTTON - Press to adjust or set the humidity. When the button indicator is lit, the humidity displayed is the set humidity. When the button indicator is not lit, the humidity displayed is the current cavity humidity or set humidity.

TIMER START/STOP BUTTON - Press to select timer function and to start/stop timer operation. The button indicator is lit when timer function is entered.

UP or DOWN ARROW - Press to set the temperature, humidity or timer.

POWER ON/OFF - Press to turn unit on/off.

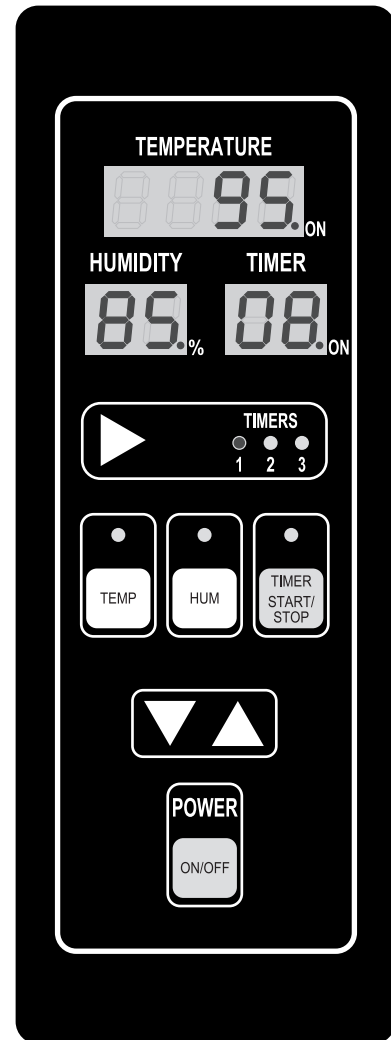

Fig. 1

TEMPERATURE

1. Press the POWER ON/OFF button to turn on the proofer.
2. If the unit is set to display the actual temperature (Fig. 2), the button indicator LED will not be illuminated.

Actual Temperature
Displayed

TEMP Button
LED Not
Illuminated

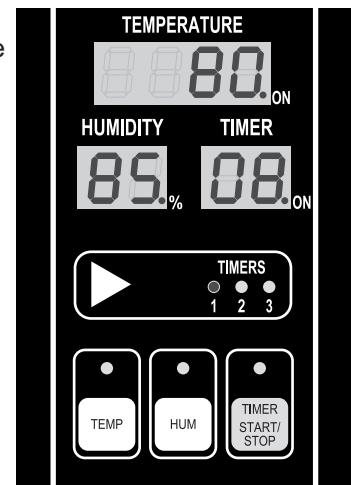

Fig. 2

3. If the unit is set to display the set temperature (Fig. 3), the button indicator LED will be illuminated. Pressing and holding the TEMP button will display the actual temperature.

Set Temperature
Displayed

TEMP Button
LED Illuminated

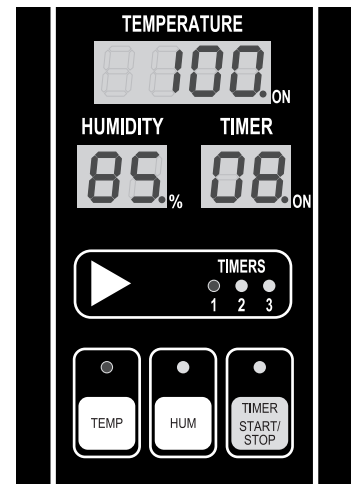

Fig. 3

Setting the Temperature

1. Press the TEMP button to adjust the set temperature. The button indicator LED will flash and the set temperature will be displayed for 5 seconds.
2. Press the up or down arrow buttons to adjust the set point while the button indicator LED is flashing.

NOTE: The temperature display will increment by 1° each time the arrow button is pressed. If you hold down the arrow button for more than 1 second, the temperature display will increment by 5° until released.

3. After pressing the arrow button, wait 5 seconds to allow the new temperature setting to save. The indicator LED will stop flashing. The TEMP display reverts back to actual or set temperature mode.

NOTE: If other setups (humidity or timers) are entered within the 5 seconds of idle time, the set temperature will be saved.

HUMIDITY

1. If the unit is set to display the actual humidity (Fig. 4), the button indicator LED will not be illuminated.

Actual Humidity Displayed

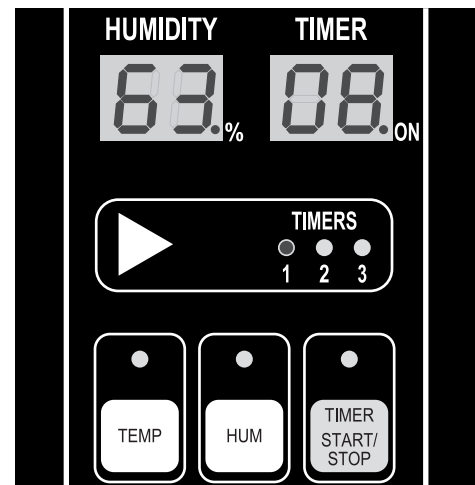

Fig. 4

2. If the unit is set to display the set humidity (Fig. 5), the button indicator LED will be illuminated. Pressing and holding the HUM button will display the actual relative humidity.

Set Humidity Displayed

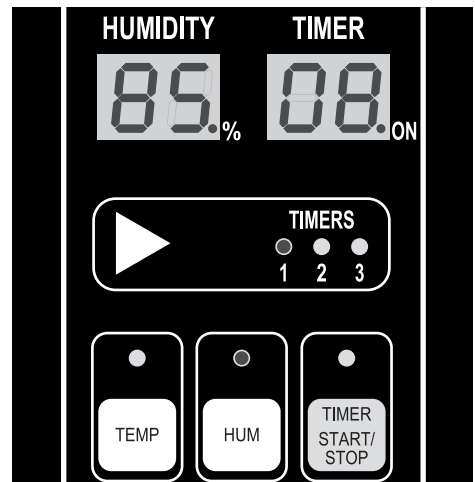

Fig. 5

Setting the Humidity

1. Press the HUM button to adjust the set humidity. The button indicator LED will flash and the set humidity will be displayed for 5 seconds.
2. Press the up or down arrow buttons to adjust the set point while the button indicator LED is flashing.

NOTE: The humidity display will increment by 1% each time the arrow button is pressed. If you hold down the arrow button for more than 1 second, the humidity display will increment by 5% until released.

3. After pressing the arrow button, wait 5 seconds to allow the new humidity setting to save. The indicator LED will stop flashing and remain off. The humidity display reverts back to actual or set as previously selected.

NOTE: If other setups (temperature or timers) are entered within the 5 seconds of idle time, the set humidity will be saved.

SETTING THE TIMER

NOTE: The timer display will initially show "00" in the display window.

1. Press the TIMER START/STOP button to select the timer function. The button indicator LED will illuminate (Fig. 6) and the timer display will show the current setting.

NOTE: If the TEMP or HUM buttons are pressed while the timer is in setup mode, the timer function will be canceled.

2. Press the arrow button next to the timers LED indicators to select a timer (1, 2 or 3). The timer display will show the timer running if the LED dot on the display is on, or the last time set for that timer.
3. Press the up or down arrow buttons to adjust the timer setting. The timer display will show 0 to 60 minutes.
4. Press the TIMER START/STOP button or the arrow button next to the timers LED indicators to save the set time.

NOTE: The timer setting will also save if no button is pressed for 3 seconds.

STARTING/ADJUSTING THE TIMER

1. After setting the timer, press the TIMER START/STOP button to start the timer operation. The LED dot on the timer display will flash to indicate the timer is operating.
2. Press the up or down arrow buttons to adjust the timer setting while the timer is in countdown mode.

NOTE: The timer will pause if the TIMER START/STOP button is pressed while the timer is running.

3. Press the TIMER START/STOP button to resume timer running.

CANCELING/STOPPING THE TIMER

1. Press and hold the down arrow until the timer display reaches "00". This initiates a stop timer.

NOTE: When the timer completes the time cycle, the buzzer pulses a short beep and the timer display flashes "00".

2. Press the TIMER START/STOP button to silence the timer.

NOTE: The temperature or humidity can be changed while the timer is running. See Setting the Temperature or Setting the Humidity.

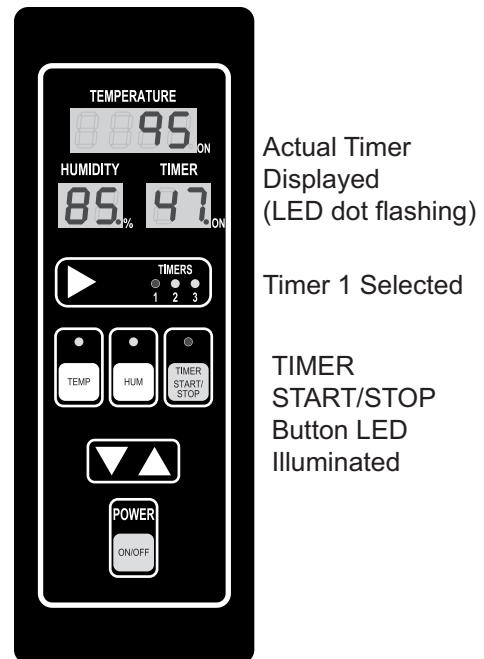

Fig. 6

PROOFING INSTRUCTIONS

1. Press POWER ON/OFF button (Fig. 7). All displays are now illuminated.
2. Set temperature (as required).
3. Set humidity (as required)

NOTE: Unit will only add humidity 10 minutes after unit has been turned on. Avoid shutting unit off if used through out the day. Maximum humidity setting is 95%.

4. Allow cold unit to heat up and balance humidity for 15-20 minutes before putting any product in the proofer.
5. Load product using standard 18" x 26" (45.7 cm x 66 cm) pans. Only load as much product as needed for one oven bake.
6. Set and start timer (as required). (Additional product may be added to proofer after allowing a lag time of the typical bake cycle from start of previous batch.)
7. If timer is used, a buzzer will sound and the control panel will flash to indicate the timer has reached "00".
8. Push TIMER START/STOP to silence alarm.
9. Remove product and prepare for oven bake.

HOLDING INSTRUCTIONS (MB100 ONLY)

1. Press POWER ON/OFF button (Fig. 7). All displays are now illuminated.
2. Set temperature (as required). If Holding is desired, hold the UP arrow for 5 seconds after it reaches 105°F and the temperature will jump to 150°F.
3. Set humidity (as required). The unit will start adding after the first 10 minutes the unit is on. Maximum humidity setting is 35%.
4. Load product using standard 18" x 26" (45.7 cm x 66 cm) pans.
5. Set and start timer (as required). (Additional product may be added to holding cabinet after allowing a lag time of the typical bake cycle from start of previous batch.)
6. If timer is used, a buzzer will sound and the control panel will flash to indicate the timer has reached "00".
7. Push TIMER START/STOP to silence alarm.

SHUTDOWN PROCEDURES

1. Remove all product.
2. Press POWER ON/OFF. All displays will not be illuminated.
3. The fan will continue to run for 15-20 minutes after power off. Crack doors during this time frame to help dry out proofer for MB300.
4. After fan shuts down, the proofer may be cleaned. See Cleaning.

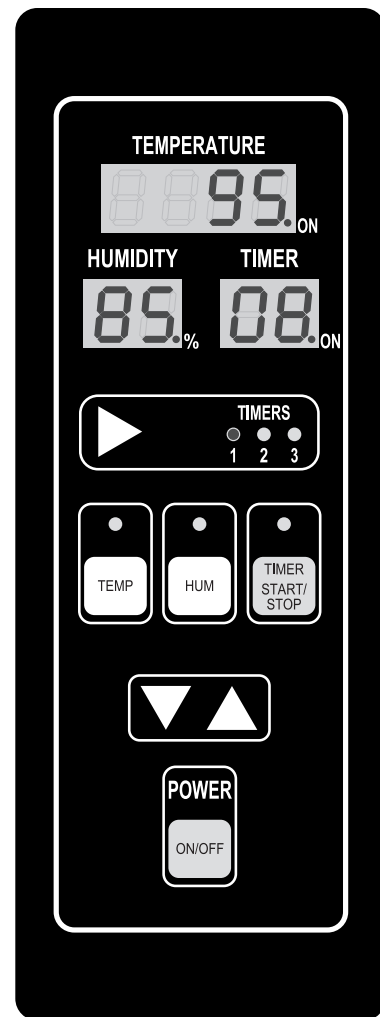

Fig. 7

CLEANING

1. Using a clean cloth moistened in warm, soapy water, wash the stainless steel interior of the cabinet. Rinse with clean water and dry with a clean cloth.
2. Clean the outside daily with a clean, damp cloth.
3. Use care when cleaning around sensitive interior parts, such as probes and sensors.
4. Do not use cleaners containing grit, abrasive materials, bleach, harsh chemicals or chlorinated cleaners. Do not use steel wool on stainless steel surfaces. Never spray down the proofer with water, steam or power wash.
5. Be cautious with new or improved cleaning formulas; use only after being well tested in an inconspicuous place.

MAINTENANCE

⚠ WARNING Disconnect the electrical power to the machine and follow lockout / tagout procedures.

SERVICE AND PARTS INFORMATION

Contact your authorized service office for any repairs or adjustments needed on this equipment.

TROUBLESHOOTING

PROBLEM	POSSIBLE CAUSE	CORRECTIVE ACTION
Controller does not turn on after POWER ON/OFF button is pressed.	1. Unit not plugged in. 2. Control panel fuse blown.	1. Check power cord at outlet. 2. Contact your authorized service office.
Temperature display flashes "00".	Sensor problem.	Contact your authorized service office.
Temperature display flashes "Err".	Sensor problem.	Contact your authorized service office.
Temperature display flashes "OUtP".	Sensor problem.	Contact your authorized service office.
Keypad does not respond.	Membrane problem.	Contact your authorized service office.
Buzzer does not sound when timer is zero.	Buzzer problem.	Contact your authorized service office.
Unit will not go to Holding temperature.	Unit not set for Holding mode.	Check parameter P9 and P14 or contact your authorized service office.

PARAMETER SET-UP MODE FOR SERVICE ONLY

To enter the set-up mode and change parameter setting, the oven should be in the “OFF” mode.

To enable the set-up mode, do the following:

1. Press and hold the “Timer Start/Stop” button and then the power “ON/OFF” button for 5 sec
2. The 2 digit LED humidity window will initially display software version for 2 sec and then displays the Parameter “P”
3. The 2 digit LED timer window will display parameter number.
4. The 4 digit LED temperature window will display the value.
5. To review the next or previous parameter setting, press either Up or Down arrow button
6. To change the setting of the selected parameter, press the “Timer Start/stop” button then press Up or Down arrow button to change the value.
7. To save the current setting and selecting another parameter, press the “Timer Start/Stop” button again
8. To exit the Set-Up Mode, press the “Power ON/OFF” button once.

The PARAMETER NUMBER is displayed in the 4 digit LED temperature display and the values are displayed in the 3 digit LED timer display.

Each of these values has a PARAMETER NUMBER as follows:

SETUP NUMBER	SETUP ITEM	DESCRIPTION	DISPLAY
P1	Degree Setting	This value changes the temperature unit on the display.	F: Fahrenheit (Default) C: Celsius
P2	Temperature Offset	This number permits an offset, or correction, between the temperature read by the probe and the real proofing chamber temperature.	Range is +15 to -15°F/C Default is 0
P3	Humidity Offset	This number permits an offset, or correction, between the humidity read by the probe and the real proofing chamber humidity.	Range is +15 to -15°F/C Default is 0
P4	Minimum Temperature (Proofing Mode)	This value acts as a minimum limit for temperature set point, and the unit will not allow the operator to set the temperature lower than this.	Range is 65 to 115°F (18 to 46°C) Default is 65°F (18°C)
P5	Maximum Temperature (Proofing Mode)	This value acts as a maximum limit for temperature set point, and the unit will not allow the operator to set the temperature higher than this.	Range is 100 to 105°F (38 to 40°C) Default is 105°F (40°C)
P6	Minimum Humidity (Proofing Mode)	This value acts as a minimum limit for humidity set point, and the unit will not allow the operator to set the humidity lower than this.	Range is 35 to 65% Default is 35

SETUP NUMBER	SETUP ITEM	DESCRIPTION	DISPLAY
P7	Maximum Humidity (Proofing Mode)	This value acts as a maximum limit for humidity set point, and the unit will not allow the operator to set the humidity higher than this.	Range is 65 to 95% Default is 90
P8	Temperature Display Mode	This value sets what the type of temperature reading it will display.	Actual Mode or Set Point Mode Default is Actual
P9 (MB100)	Sensor Mode	This value changes the temperature limit on the controller.	1735 Mode will limit the controller up to 170°F (Proof/Hold) 2500 Mode will limit the controller up to 115°F. (Proof Only) Default is 2500
P9 (MB300)	Sensor Mode	This value changes the temperature limit on the controller.	2500 Mode will limit the controller up to 115°F. (Proof Only) Default is 2500
P10 (MB100)	Minimum Temperature (Holding Mode)	This value acts as a minimum limit for temperature set point, and the unit will not allow the operator to set the temperature lower than this.	Range is 150 to 155°F (60 to 66°C) Default is 150°F (18°C)
P11 (MB100)	Maximum Temperature (Holding Mode)	This value acts as a maximum limit for temperature set point, and the unit will not allow the operator to set the temperature higher than this.	Range is 155 to 170°F (68 to 76°C) Default is 170°F (76°C)
P12 (MB100)	Minimum Humidity (Holding Mode)	This value acts as a minimum limit for humidity set point, and the unit will not allow the operator to set the humidity lower than this.	Range is 15 to 35% Default is 15
P13 (MB100)	Maximum Humidity (Holding Mode)	This value acts as a maximum limit for humidity set point, and the unit will not allow the operator to set the humidity higher than this.	Range is 35 to 50% Default is 50
P14	Mode Selection	This value sets the unit as Proofer only or Proofer/Holder.	ProF = Proofer Hold = Proofer/Holder - MB100 Only Default is ProF

NOTES