

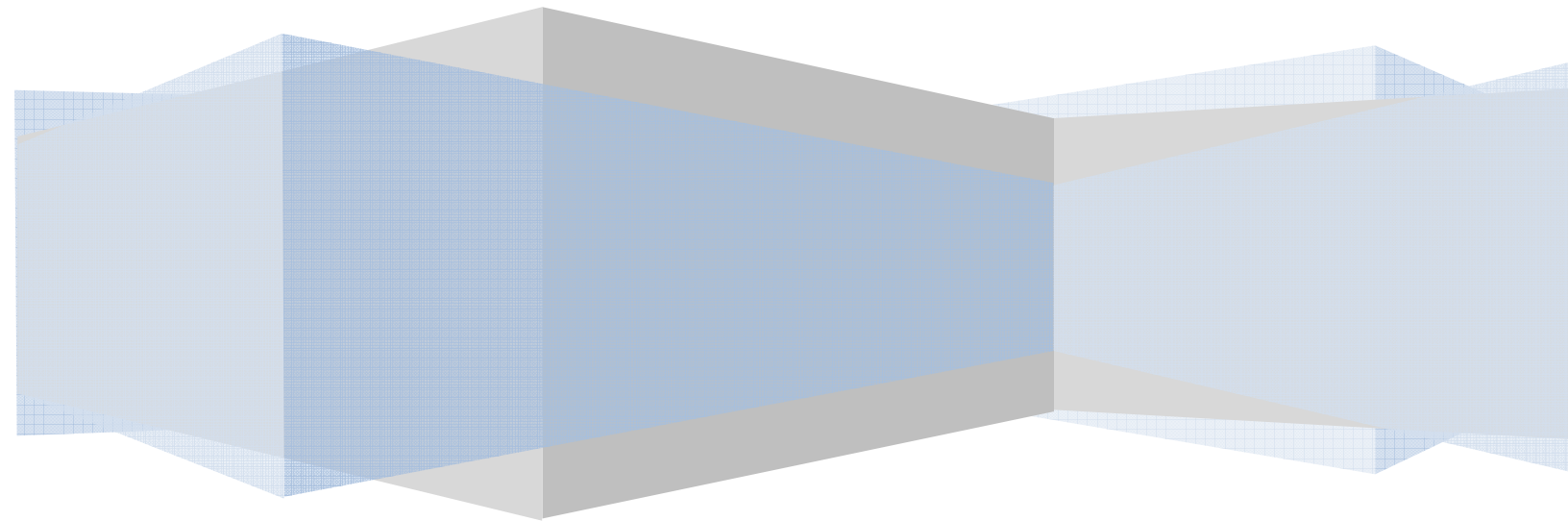

Foodservice Equipment Specialists
P.O. Box 880 Saco, ME. / U.S.A. 04072
877-854-8006 * FAX (207) 283-8080

FIELD SERVICE MANUAL
CONVEYOR OVEN MODEL
MDG-18



**FIELD SERVICE MANUAL
CONVEYOR OVEN MODEL
MDG-18**

UNCRATNG AND INSPECTION	PAGE 2
ASSEMBLY AND INSTALLATION	PAGE 2
ELECTRICAL INSTALLATION	PAGE 2
OPERATIONAL SEQUENCE	PAGE 3
TROUBLESHOOTING GUIDE	PAGE 4, 5, 6, 7, 8
DRIVE SYSTEM COMPONENTS	PAGE 9, 10
DIGITAL DISPLAY CONTROL	PAGE 11
WIRE DIAGRAMS	PAGE 12, 13, 14
HEATER ELEMENTS	PAGE15
PARTS BREAK DOWN	PAGE 15
EXPLODED VIEWS	PAGE 16

**FIELD SERVICE MANUAL
CONVEYOR OVEN MODEL
MDG-18**

UNCRATING AND INSPECTION

Unpack the unit and components from the shipping container. Remove all visible packing materials including those that may be inside the baking chamber. If damage is discovered, file a claim immediately with the carrier that handled the shipment.

ASSEMBLY AND INSTALLATION

The equipment is shipped fully assembled and ready to plug into a matching outlet specified for its specific voltage and amperage rating. Removal or replacement of the power cord and plug will VOID the warranty. For assistance, contact the Belleco, Inc. Service Team at 1-877-854-8006. Please refer to the appropriate schematic at the rear of this manual for plug configurations. Consult with a licensed electrician prior to installation. Do not operate this equipment without the crumb trays properly installed as this may cause overheating and loss of productivity.



CAUTION – During installation: Do not place on surfaces or near walls, partitions or kitchen furniture and the like – unless they are made of non-combustible material or clad with non-combustible heat-insulating material, and pay attention to fire prevention regulations.



CAUTION – To reduce the risk of fire, the appliance is to be installed in non-combustible surroundings only, with no combustible material within 18 inches of the sides, front, or rear of the appliance or within 40 inches above the appliance. Food may burn. Therefore equipment must not be used near or below curtains and other combustible materials. They must be watched.

ELECTRICAL INSTALLATION



WARNING – Disconnect the unit from its power source before installing or removing any parts.



WARNING – Check with your local power company or licensed electrician before installation to determine the actual voltage at the outlet. For a unit rated 208 volts, never plug it into 240 volts as serious overheating and damage could occur. For a unit rated 240 volts, never plug it into 208 volts as the lower voltage will greatly reduce the productivity of the unit.

WARNING – NEVER operate any piece of equipment without proper GROUND connection. Improper grounding may result in serious personal injury or could be fatal!

**FIELD SERVICE MANUAL
CONVEYOR OVEN MODEL
MDG-18**

OPERATIONAL SEQUENCING:

POWER SUPPLY: Power is supplied to the oven through a 10 gauge cord with a 6-30P plug. Depending on voltage of oven ordered, power supply is to be either 208 or 240 volts single phase at the outlet.

MAIN POWER: Toggle located at the rear of the unit. When in the ON position the main relay is energized. Power is supplied through a 30 AMP fuse to the A/C transformer and the DC power supply.

AUTO COOLING FEATURE: Power is permanently supplied to the normally open thermostat (fan switch). When temperatures reach 120°F +/- 3°F (48.9°C +/- 3° C) the switch closes energizing the cooling fans. The switch will open when the control box temperature is reduced to 90°F +/- 3°F (32.2°C +/- 3°C) interrupting power to the cooling fans.

OVER TEMP (HI-LIMIT/RESET): In the event of an over heat situation causing the temperature in the control box to exceed 190°F +/- 3°F (87.7°C +/- 3°C) the hi-limit/reset switch will open interrupting power to the heat and drive systems. Once the unit has cooled down the hi-limit/reset may be manually reset energizing the controls.

HEAT CIRCUIT RELAYS: The four heat relay coils are energized through connection J13 on the on the digital control panel.

CONVEYOR DRIVE CURCUIT: The DPDT relay for the drive motor is energized when the Soft Power Button on the control panel is pressed.

DIGITAL DISPLAY- TEMP/SPEED CONTROLLER: The digital display controller receives 24 VAC power at board connection J38 from the A/C transformer when the Soft Power Switch is in the ON position.

**FIELD SERVICE MANUAL
CONVEYOR OVEN MODEL
MDG-18**

MGD-18 Troubleshooting Guide

<u>Symptom</u>	<u>Cause</u>	<u>Solution</u>
Oven will not turn on, display is blank	No power at outlet. Master On/Off switch at rear of unit in the Off position. 30 amp fuse is blown.	Verify voltage at outlet. Check breaker in wall panel to make sure it is not tripped. Put Master On/Off in the ON position. Check for broken element and Identify potential short to ground. Replace fuse after issue is resolved.
Display shows Probe Alarm (prb1, prb2, prb3, prb4). Control emits a continuous beep	Temperature probe in zone is not responding.	Press any key to turn off the beep. Check for loose connections to probes at terminal block and control board.
One heat zone will not turn on	Possible burned out heater tube in zone. Loose connection at terminal block (see wire diagram). Loose connection at heat relay or defective relay	Examine all heater tubes in heat zone. Check for physically broken heater tube or burned coil inside glass covering. Inspect connections at terminal block and heat relays. If possible swap heat relay with a working relay to see if heat comes on. If heat comes on replace defective relay.
Display will not change from WARMING to REDY	One heat zone may not be on. Supplied voltage to oven may be too low (i.e. 240 volt oven running on 208 volts).	Examine heat zones to be sure all elements are working. Factory default temperatures are set at 350° (F). Verify voltage at the outlet. Supplied voltage must match rating on data label.
Display changes from WARMING to HEATING and does not read REDY	Temperature threshold has been reached.	Reduce zone temperatures to allow the elements to cycle. If zone temperatures are set above 455° (F) the oven changes to heating mode as the elements are now at full intensity and will not cycle on and off. <i>Due to airflow and heat zones most products can be cooked at lower temperatures.</i>
Conveyor will not reverse direction	Obstruction in conveyor belt. Speed button has not been pressed. Relay for drive system is not engaging.	Check for and clear obstructions in conveyor belt. Press and hold speed button until unit beeps once then release button. Conveyor will stop and after approximately 10 seconds conveyor will reverse direction. Replace relay.
Conveyor speed will not change	Set button not pressed after setting new speed. Driver board defective.	Once new conveyor speed has been entered press the set key to save changes. Verify signal to the driver board and replace board if necessary (see troubleshooting on page 6).
Conveyor will not turn, heat works	Obstruction in conveyor belt. No power to speed board from control. No voltage signal to driver board or drive motor. Drive motor defective.	Check for and clear any obstructions in conveyor belt. Verify there is 24 volts AC from controller to speed board. Verify voltage signal from speed board to driver board. Verify DC voltage to drive motor from drive board. Check 1 amp fuse at rear of oven to make sure it is not blown. Check DC power supply to make sure it is providing 24 VDC to drive board.

For additional assistance contact Belleco's Factory Service Team at 877-854-8006

(Continued page 5)

**FIELD SERVICE MANUAL
CONVEYOR OVEN MODEL
MDG-18**

**TROUBLE SHOOTING CONTINUED
CONVEYOR DRIVE SYSTEM FLOW CHART**

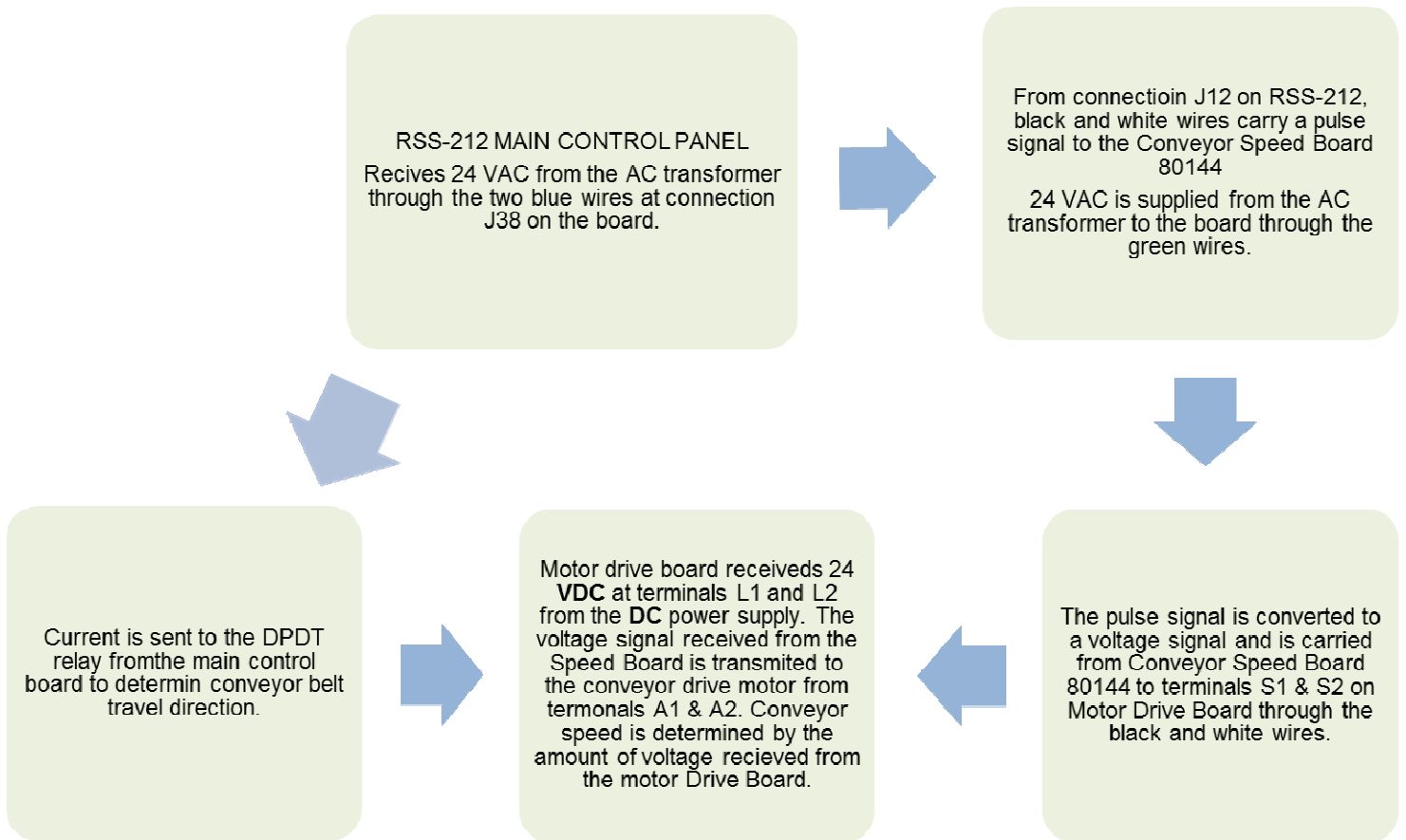

Note: refer to page 9 for component layout

(Continued page 6)

**FIELD SERVICE MANUAL
CONVEYOR OVEN MODEL
MDG-18**

CONVEYOR WILL NOT TURN

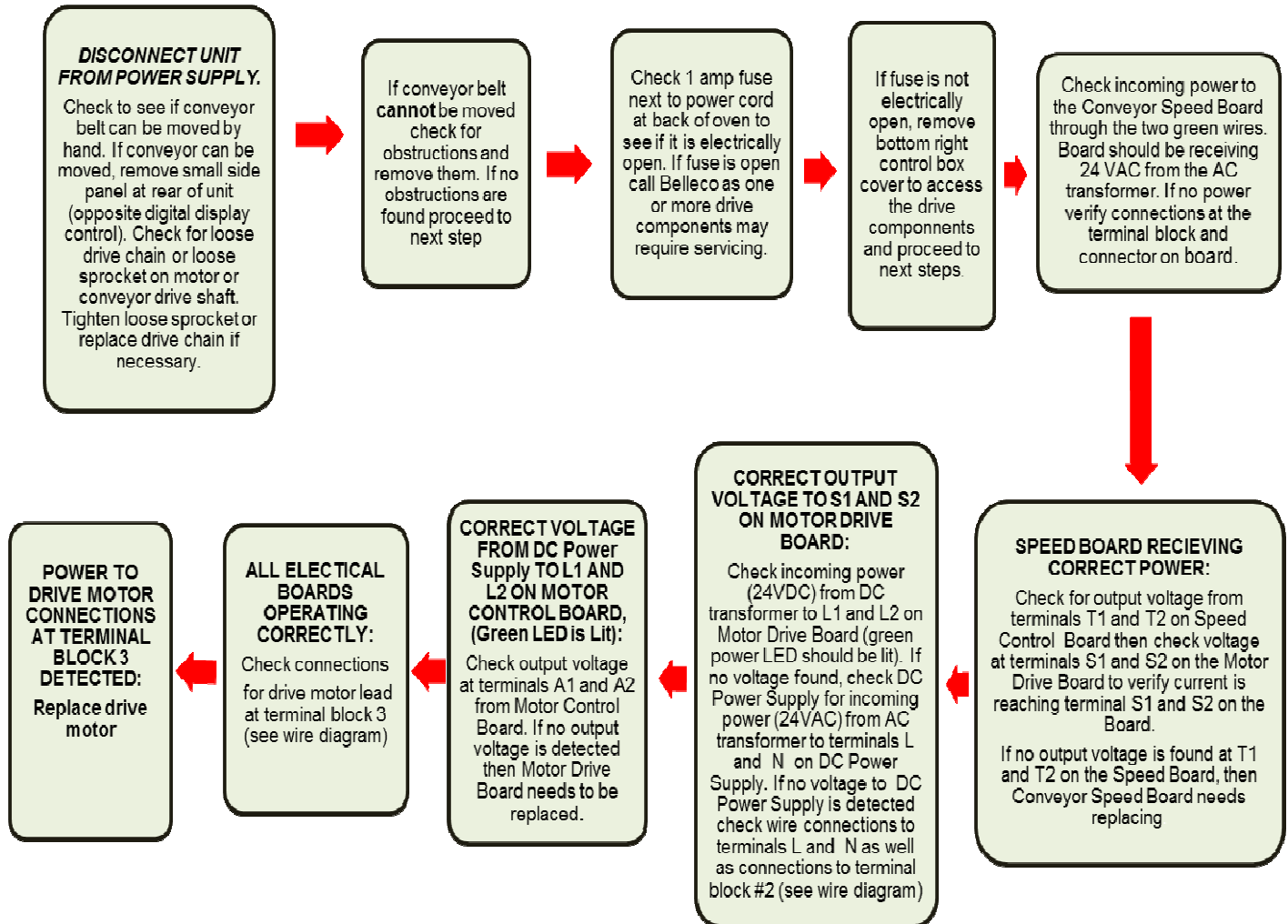

Note: refer to page 9 for component layout

(Continued page 7)

**FIELD SERVICE MANUAL
CONVEYOR OVEN MODEL
MDG-18**

HEAT SYSTEM FLOW CHART

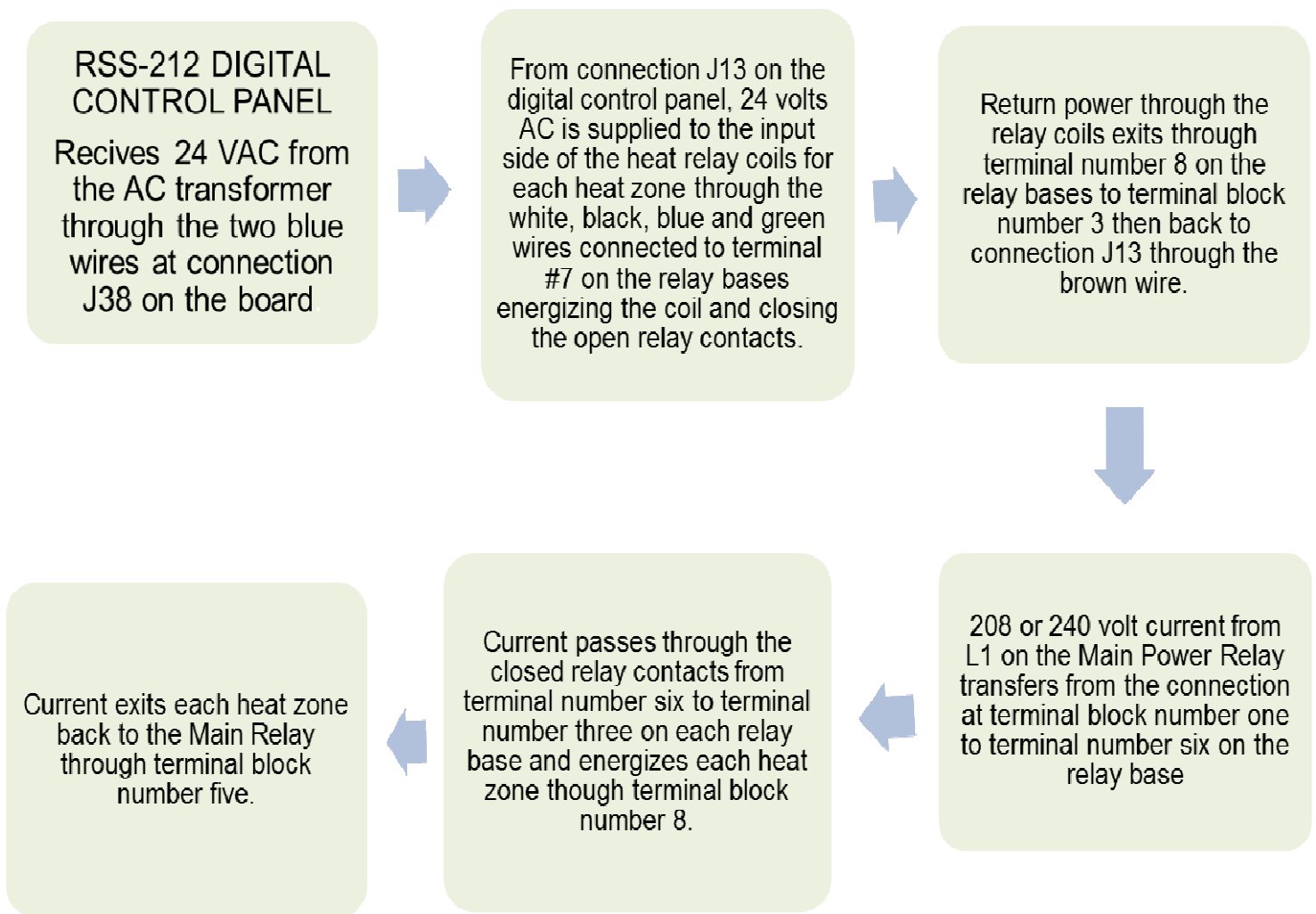

Note: refer to page 9 for component layout

(Continued page 8)

**FIELD SERVICE MANUAL
CONVEYOR OVEN MODEL
MDG-18**

ONE OR MORE HEAT ZONES WILL NOT WORK

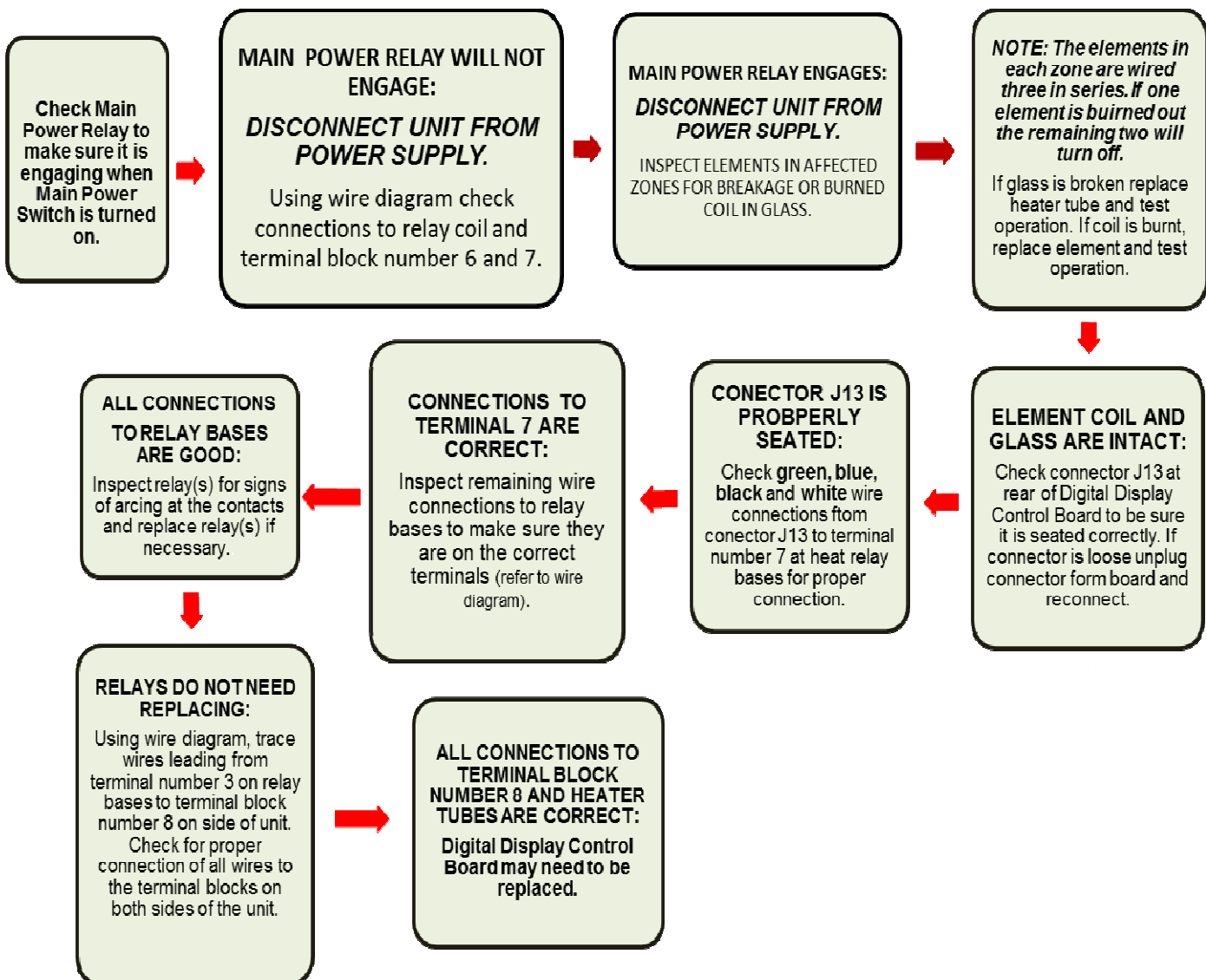

Note: refer to page 9 for component layout

**FIELD SERVICE MANUAL
CONVEYOR OVEN MODEL
MDG-18**

MAIN PANEL COMPONENT LAYOUT

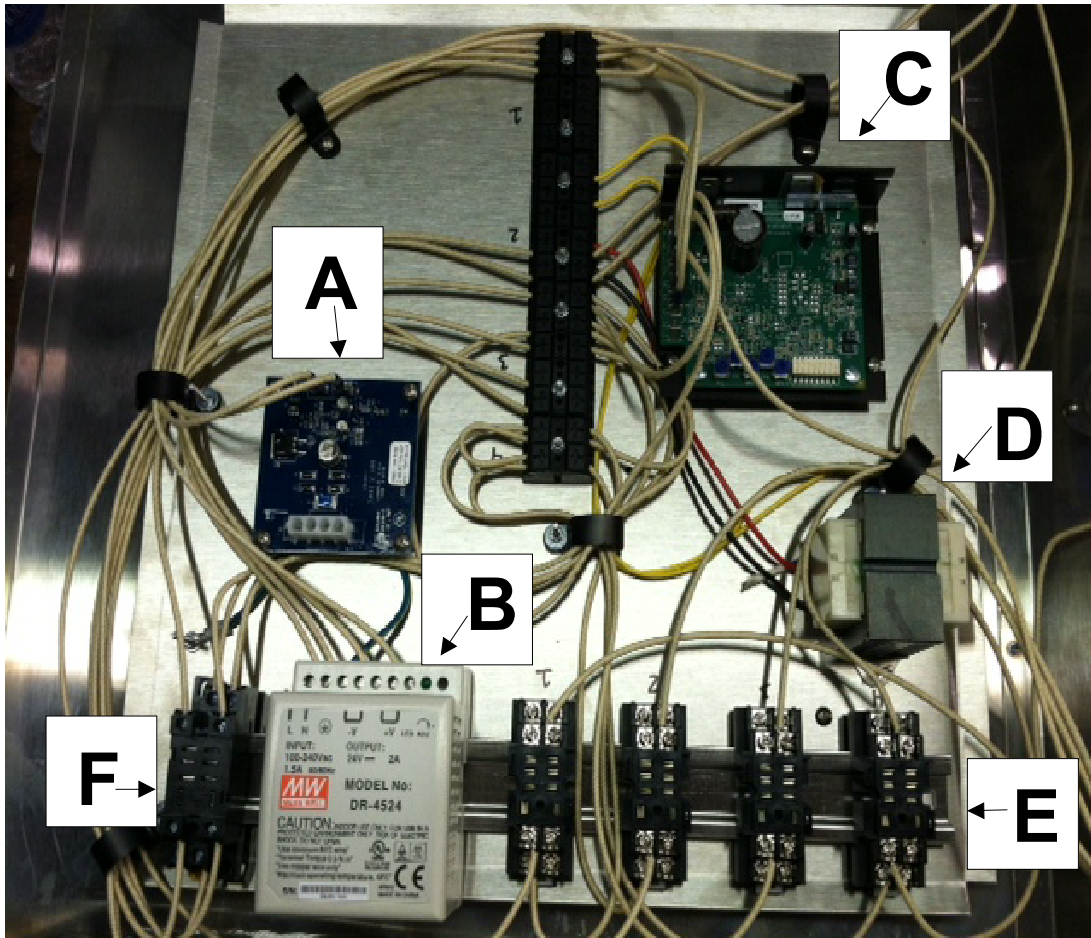

- A – Conveyor Speed Board**
- B – Power Supply, 24V DC**
- C – Motor Driver Board**
- D – Transformer, 24V AC**
- E – Heat Relay Bases (4 ea.)**
- F – DPDT Drive Relay (1 ea.)**

**FIELD SERVICE MANUAL
CONVEYOR OVEN MODEL
MDG-18**

SECONDARY PANEL COMPONENT LAYOUT

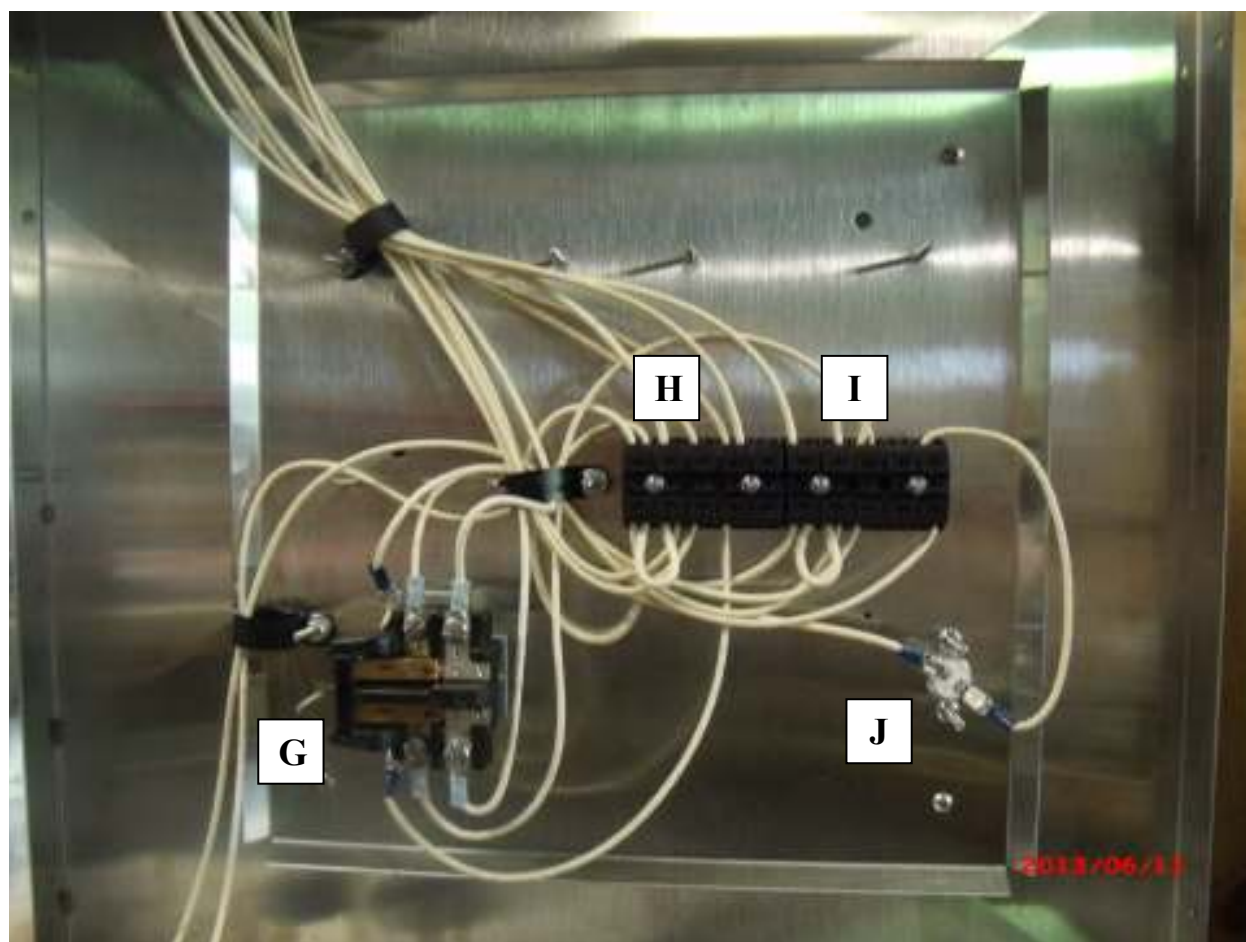

- G – Contactor/Relay**
- H – Terminal Block #6**
- I – Terminal Block #7**
- J – Fan Switch**

**FIELD SERVICE MANUAL
CONVEYOR OVEN MODEL
MDG-18**

BACK SIDE VIEW OF CONTROL PANEL

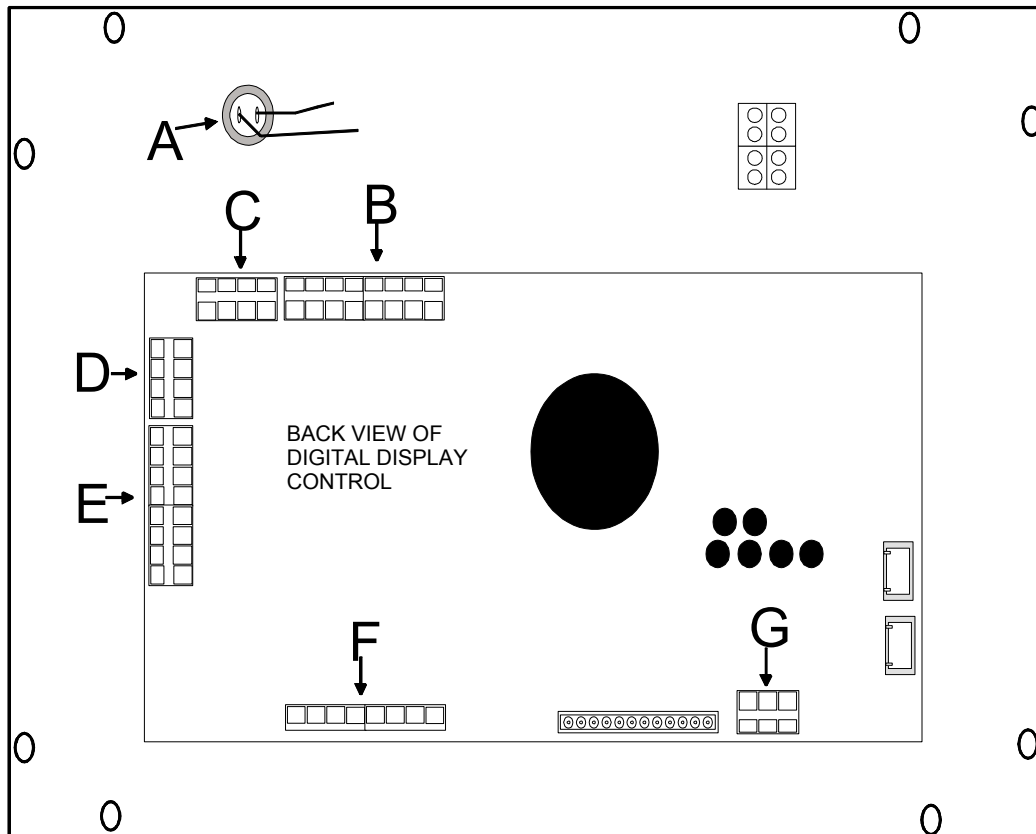

- A – ON/OFF Switch, Push Button**
- B – Connector J12 (Wires to Speed Board)**
- C – Connector J7 (Heat Probes Zone 3 & 4)**
- D – Connector J1 (Heat Probes Zone 1 & 2)**
- E – Connector J37 (ON/OFF Switch, Soft Power)**
- F – Connector J13 (24 VDC Out To Heat and Drive Relays)**
- G – Connector J38 (Incoming 24 VAC power)**

**FIELD SERVICE MANUAL
CONVEYOR OVEN MODEL
MDG-18**

MOTOR DRIVE BOARD

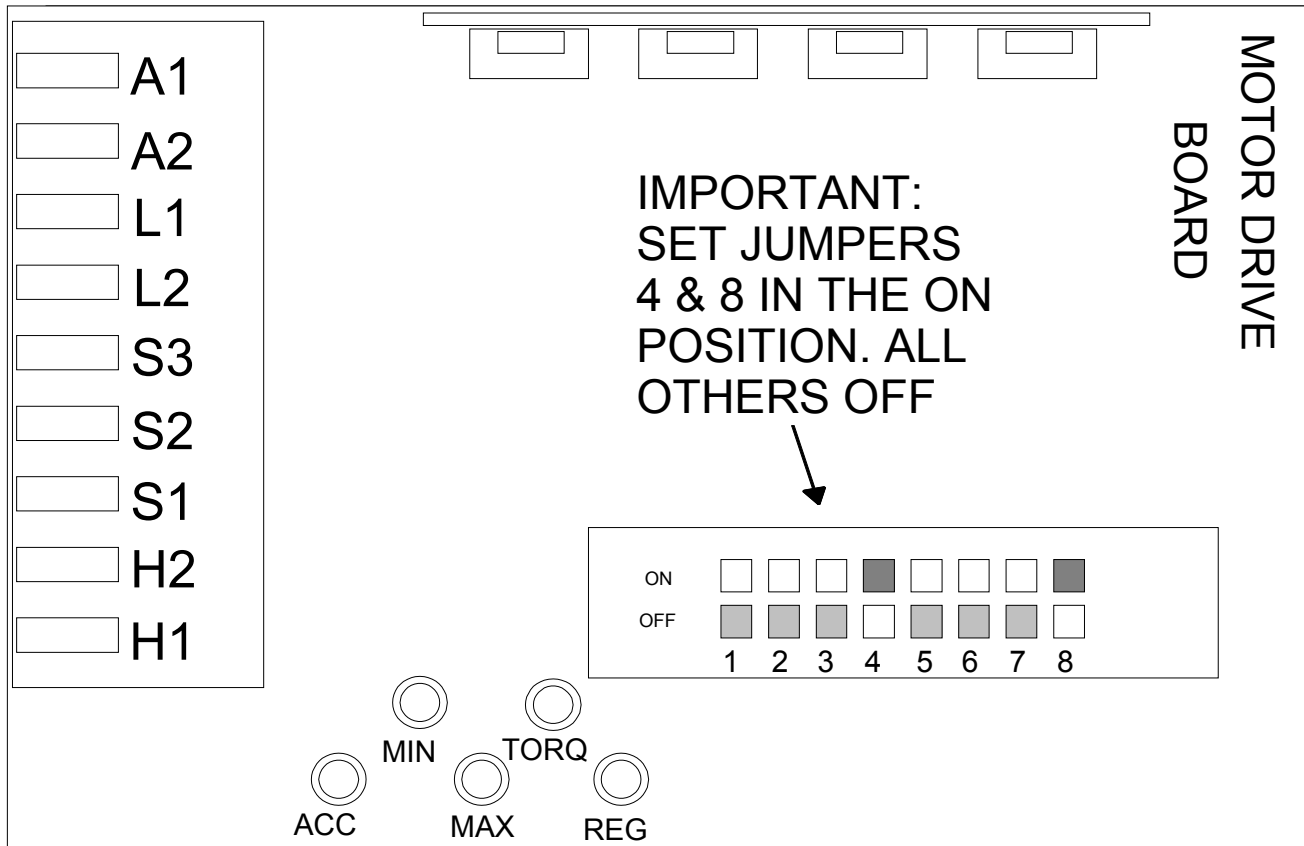

z:\warranty\mclavet\wirediagram\mgdov\bodine.ds4

REMOVING NON-WORKING BOARD:

- 1). DISCONNECT UNIT FROM POWER SUPPLY.
- 2). Tag each wire connecting to terminals on board before removing wires.
- 3). Carefully disconnect wires from terminal.
- 4). Remove four (4) Philips head mounting screws and remove board.

INSTALLING NEW BOARD:

WARNING: THIS COMPONENT IS STATIC SENSITIVE. DO NOT SET ON METAL SURFACE WHILE HANDLING BOARD.

- 1). IMPORTANT – SET JUMPERS ON NEW BOARD BEFORE INSTALLING AS SHOWN ABOVE.
- 2) DO NOT TOUCH BLUE TRIM POTS ON BOARD.
- 3). Install new board and secure using 4 Philips head screws removed in step 4 above.
- 4). Connect wires to board and test.

FIELD SERVICE MANUAL
 CONVEYOR OVEN MODEL
MDG-18

WIRE DIAGRAM

REVISION			
REV	DATE	DESCRIPTION	ECN #
D	7/22/13	chg probe positions on drawing	MJC

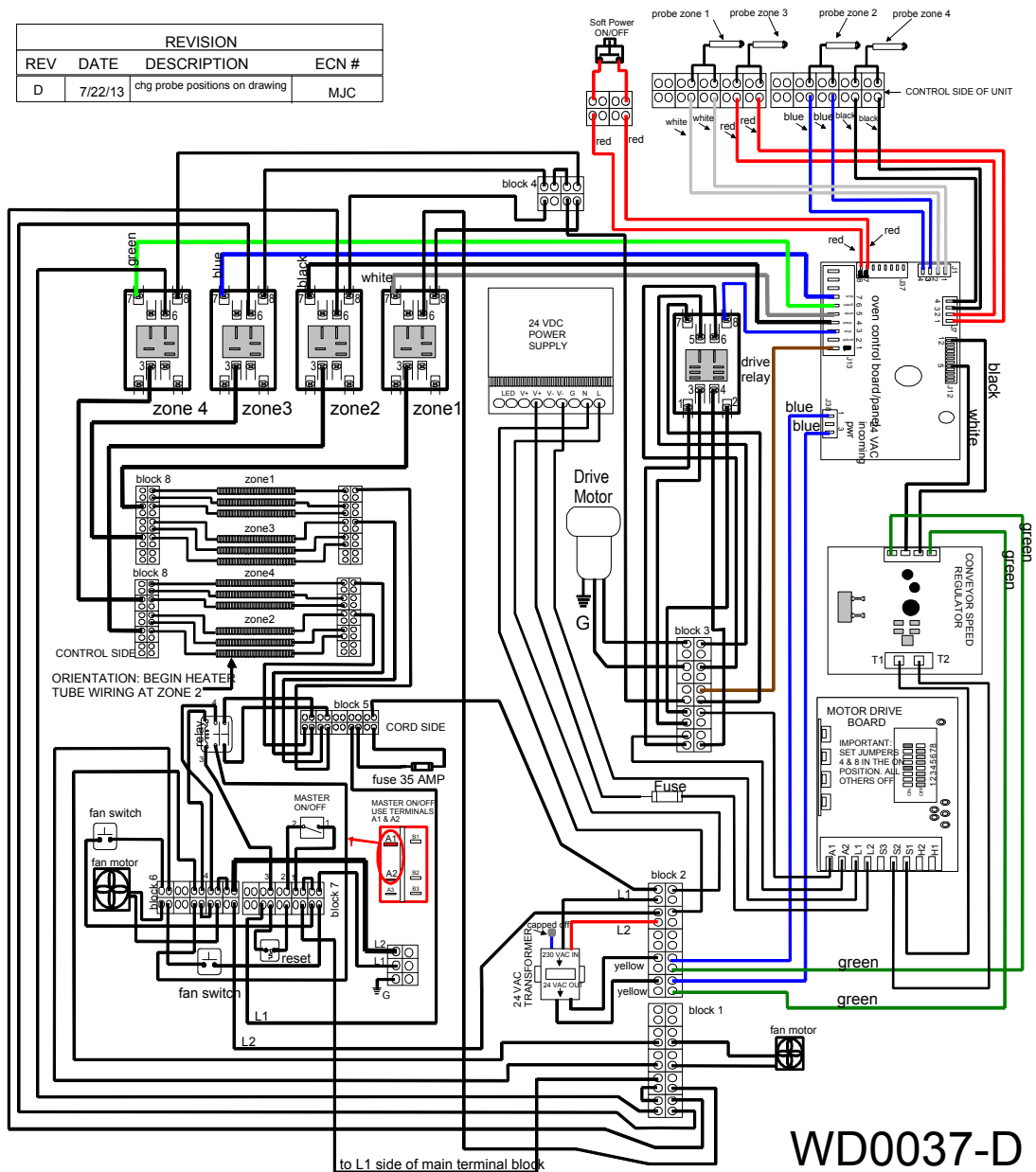

BELLECO INC. FOOD EQUIPMENT SPECIALISTS P. O. BOX 880 SACO ME 04072	DRAWN BY: MICHAEL CLAVET	HEATER TUBE WIRE DIAGRAM MDG - 18 OVEN 208, 240 VOLT SINGLE PHASE
	DATE: 07/16/2013	

**FIELD SERVICE MANUAL
CONVEYOR OVEN MODEL
MDG-18**

DRIVE SYSTEM WIRE DIAGRAM

REVISION			
REV	DATE	DESCRIPTION	ECN #

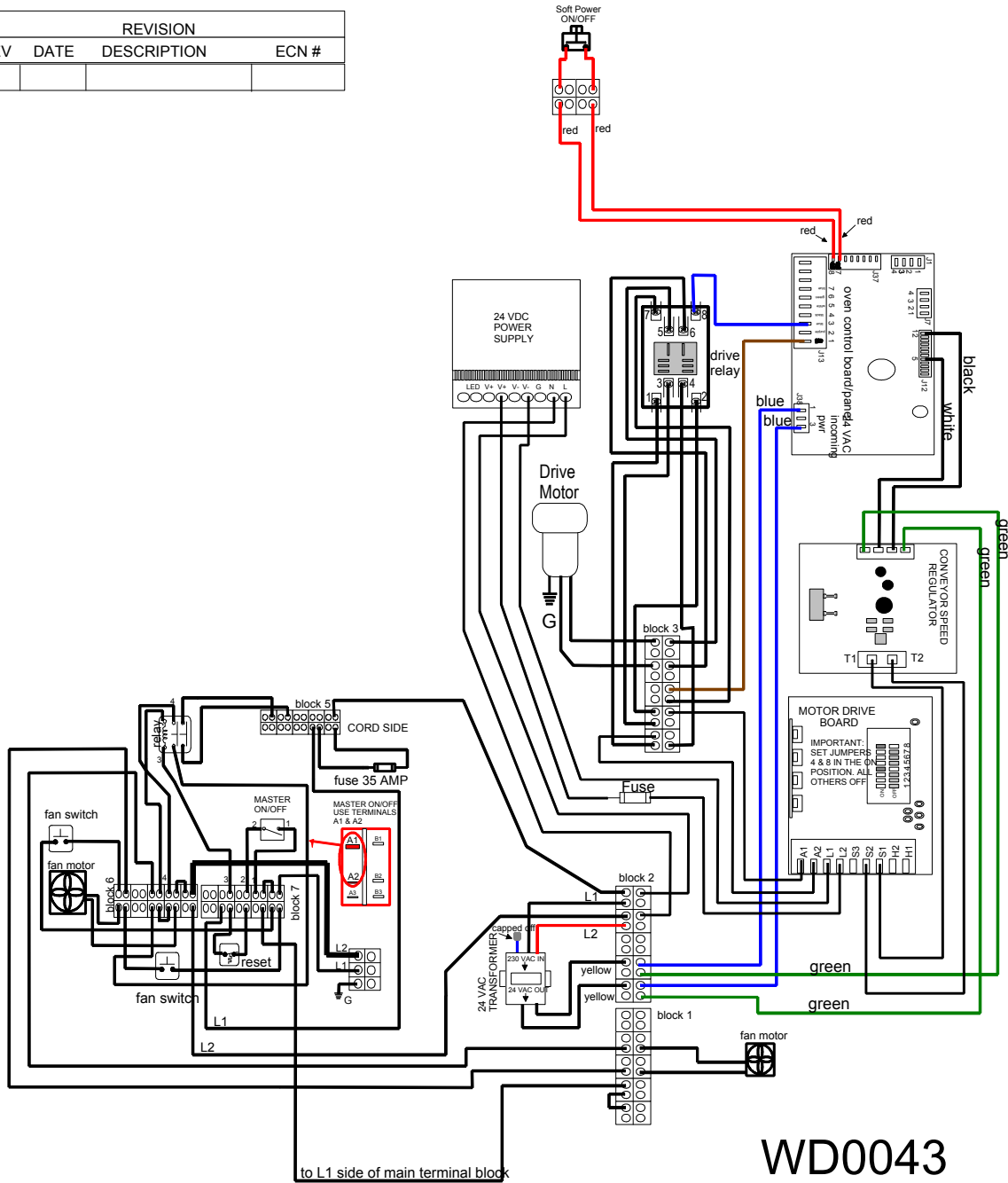

WD0043

BELLECO INC. FOOD EQUIPMENT SPECIALISTS P. O. BOX 880 SACO ME 04072	DRAWN BY: MICHAEL CLAVET	DRIVE SYSTEM DIAGRAM MDG - 18 OVEN 208, 240 VOLT SINGLE PHASE
	DATE: 08/23/2013	

**FIELD SERVICE MANUAL
CONVEYOR OVEN MODEL
MDG-18**

HEAT SYSTEM WIRE DIAGRAM

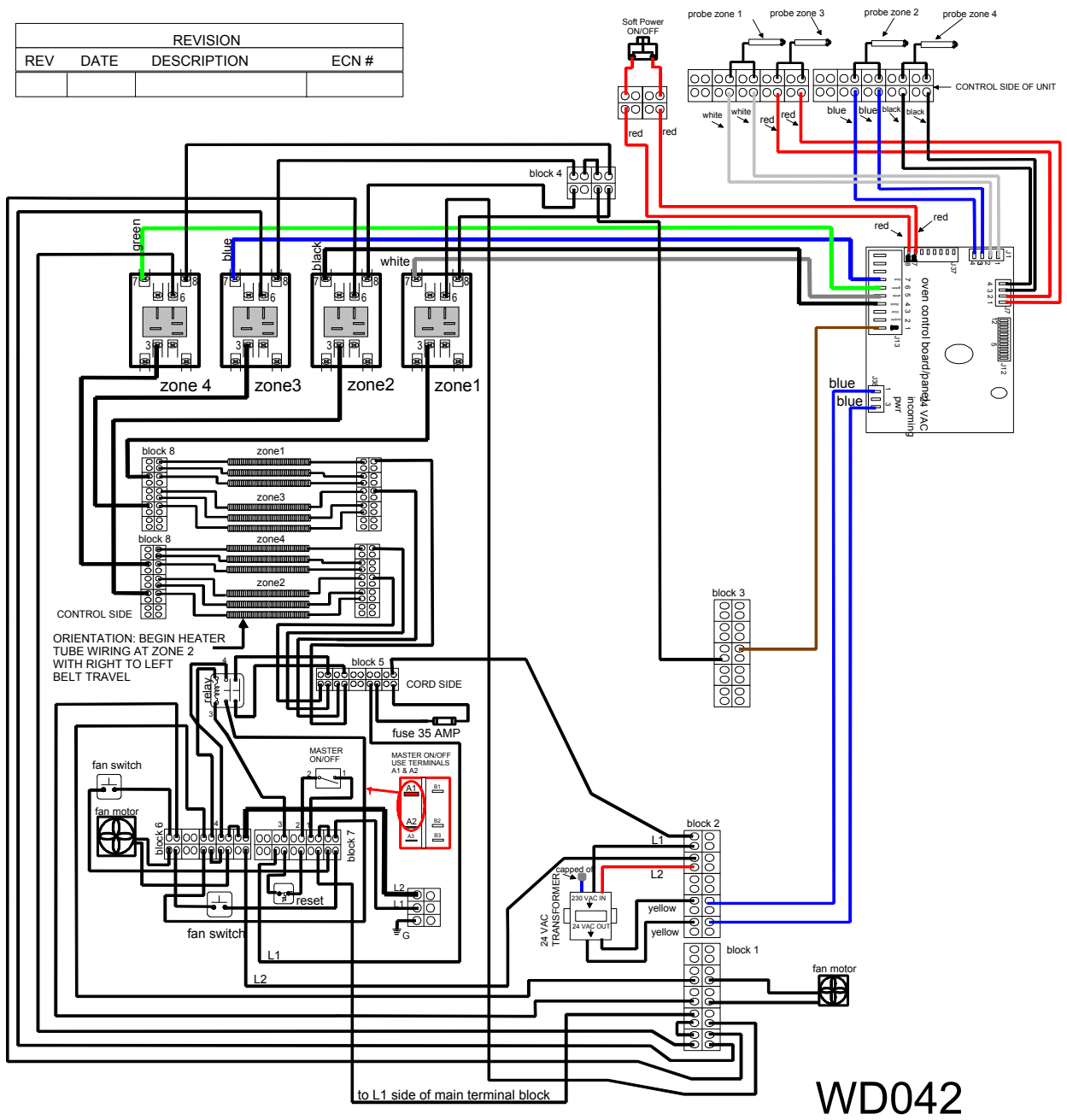

REVISION			
REV	DATE	DESCRIPTION	ECN #

BELLECO INC. FOOD EQUIPMENT SPECIALISTS P. O. BOX 880 SACO ME 04072	DRAWN BY: MICHAEL CLAVET	HEATER SYSTEM WIRE DIAGRAM MDG - 18 OVEN 208, 240 VOLT SINGLE PHASE
	DATE: 08/23/2013	

**FIELD SERVICE MANUAL
CONVEYOR OVEN MODEL
MDG-18**

PARTS LIST

<u>DESCRIPTION</u>	<u>QTY</u>	<u>PART No.</u>	<u>DESCRIPTION</u>	<u>QTY</u>	<u>PART No.</u>
Drive Motor	1	401215	Relay, Heaters, 24VDC, SPDT	4	401156
Sprocket, Driven, 25B 24 x 3/8	1	401304	Socket, Heat Relay	4	401171
Sprocket, Drive, 25B11 x 5/16	1	401301	Clip, Heater Relay	8	401172
Chain ,Ladder, Drive 21 1/4"	1	401399	Fuse, 30 Amp KTK-R-30 600V	1	401169
Conveyor Drive Shaft	1	201987	Fuse Holder w/Wires	1	202051
Conveyor Idler Shaft	1	201986	Power Switch, Push Button Red	1	202052
Conveyor Belt, 82.5"	1	201987	Toggle, Main Power Switch	1	401116
Support, Conveyor Belt	1	401370	Switch, Hi-Limit/Reset	1	401100
Quick Clips, Master Links	4	401337	Switch, Fan Motor	1	401107
Bushing, Spring Loaded	2	401353	Motor, Fan	2	401211
Conveyor Speed Board, 24V	1	401153	Guard, Fan Motor	2	401220
Spring, Front Busing Idler Shaft	2	400263	Cord, Fan Motor	1	401060
Motor Control Board, 24VDC	1	401163	Cord, Power, 10/3, 6-30P	1	401059
Rear Bushing Assembly, 3/8"	2	201101	Contacto, 6X566	1	401136
Power Supply, 24VDC	1	401164	Leg, 4" Metal	4	400301
Transformer, 24VAC	1	401155	Knob, Heat Shutter	4	401188
Fuse, 1 Amp 4XH40	1	401167	Tray, Load Up	1	305774
Fuse Holder, 1 Amp	1	401148	Tray, Unload	1	100206
Socket, Motor Relay	1	401170	Crumb Tray Assembly	2	100212
Relay, Motor, 24VDC, DPDT	1	401157	Heat Shutter	2	305755
Digital Display Control	1	401152	Heater Tube, 208V, 546W	12	204246
Probe, Temperature	4	401154	Heater Tube, 240V, 546W	12	204247
Retainer Plate, Heater Tube	4	305749			

**FIELD SERVICE MANUAL
CONVEYOR OVEN MODEL
MDG-18**

ASSEMBLY EXPLODED VIEW