

OWNER/OPERATOR MANUAL



MODELS 909A & 919A SLICERS

NOTICIA IMPORTANTE

Este manual contiene importantes instrucciones de seguridad que deben ser seguidas al pie de la letra cuando utilice esta máquina.

IMPORTANT NOTICE

This manual contains Important Safety Instructions which must be strictly followed when using this equipment.

BEFORE USING THIS EQUIPMENT

Berkel's slicers are designed to slice meat and other food products safely and efficiently. However, unless the operator is properly trained and supervised, there is the possibility of a serious injury. It is the responsibility of the owner to ensure that this slicer is used properly and safely, strictly following the instructions contained in this manual and any requirements of local law.

No one should use or service this slicer without proper training and supervision. All operators should be thoroughly familiar with the procedures contained in this manual. Even so, Berkel cannot anticipate every circumstance or environment in which its slicers will be used. You, the owner and operator, must remain alert to the hazards posed by the function of a slicer—particularly the sharp rotating blade and moving table. No one under 18 years of age should operate this equipment. If you are uncertain about a particular task, ask your supervisor.

This manual contains a number of safe practices in the General Safety Instruction Section. Additional warnings are placed throughout this manual. **WARNINGS RELATED TO YOUR PERSONAL SAFETY ARE INDICATED BY:**

WARNING

If any warning label, wall chart or manual becomes misplaced, damaged or illegible, please contact your nearest distributor or Berkel directly, for a free replacement.

Remember, however, **THIS MANUAL OR THE WARNING LABELS DO NOT REPLACE THE NEED TO BE ALERT AND TO USE YOUR COMMON SENSE WHEN USING THIS SLICER.**

TABLE OF CONTENTS

	<i>Page</i>
General Safety Instructions	2
Equipment Description	4
Installation	6
Assembly	7
Testing Prior to Operation	8
Operating Instructions	10
Sharpener Maintenance	12
Cleaning and Sanitizing	13
Sharpening	16
Optional Accessories	17
Troubleshooting	18
Repair Parts/Repair Service	19
Specifications	20
Warranty	21

The Berkel Company • World's Leading Manufacturer of Slicer and Food Processing Equipment

BERKEL COMPANY

4406 Technology Drive · South Bend, Indiana 46628-9770

574/232-8222 · Fax 574/232-8116

(800) 348-0251

⚠ PELIGRO

CUCHILLA FILOSA

para evitar serios accidentes a su persona siga las instrucciones de este manual y

1. NUNCA utilice esta máquina sin previa instrucción y autorización de su supervisor.
2. LA MÁQUINA DEBE apoyarse sobre un nivel sólido y plano.
3. LOS PROTECTORES deben colocarse ANTES de enchufar y operar la máquina.
4. SIEMPRE utilice el enchufe original proveído por el fabricante.
5. SIEMPRE utilice el utensillo para empujar la comida - nunca su mano.
6. NUNCA TOQUE LA CUCHILLA CON LA MANO.
7. MANTENGA manos, brazos, cabello y ropa suelta LEJOS de toda parte en movimiento de la máquina.
8. EN CASO DE QUE LA MÁQUINA SE TRABE, apague y desconecte ANTES de sacar lo que la obstruye.
9. APAGUE Y DESCONECTE LA MÁQUINA antes de limpiar, sanitizar, o arreglar.
10. UTILIZE UNICAMENTE los repuestos provistos por el fabricante.
11. EN CASO de que los mambretes de 'PELIGRO' se desprendan de la máquina o sean ilegibles, llame al fabricante o a su representante de service Berkel para que lo reemplace sin cargo.

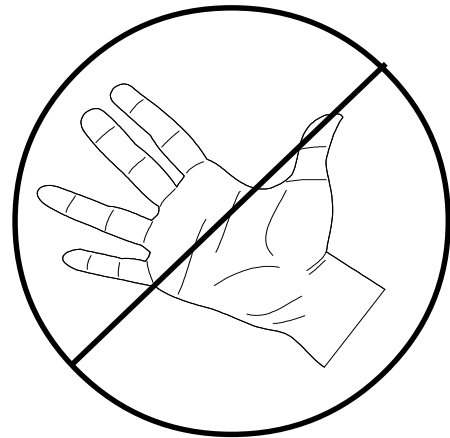

⚠ WARNING
SHARP KNIFE BLADE
to avoid serious personal injury
follow all the instructions in this manual
and

1. NEVER touch this machine without training and authorization by your supervisor.
2. MACHINE MUST BE on solid level support.
3. GUARDS MUST BE in place before plugging in and turning on machine.
4. ALWAYS use three pronged plug provided.
5. ALWAYS use food pusher not your hand.
6. NEVER TOUCH ROTATING KNIFE.
7. KEEP hands, arms, hair and loose clothing clear of all moving parts.
8. SHOULD MACHINE JAM, turn off and unplug before removing obstruction.
9. TURN OFF AND UNPLUG machine from power source before cleaning, sanitizing or servicing.
10. USE ONLY the attachments provided by the manufacturer.
11. SHOULD any warning label on a machine come off or become unreadable, contact the manufacturer or your Designated Berkel Service Location for a free replacement.

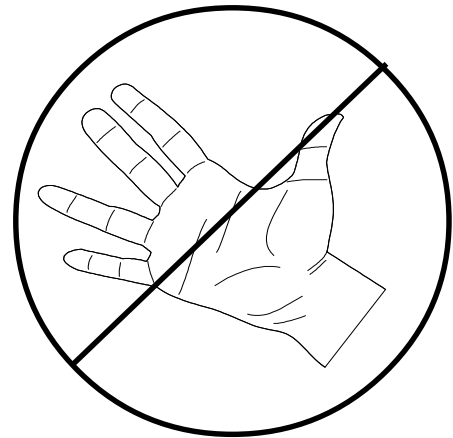

EQUIPMENT DESCRIPTION

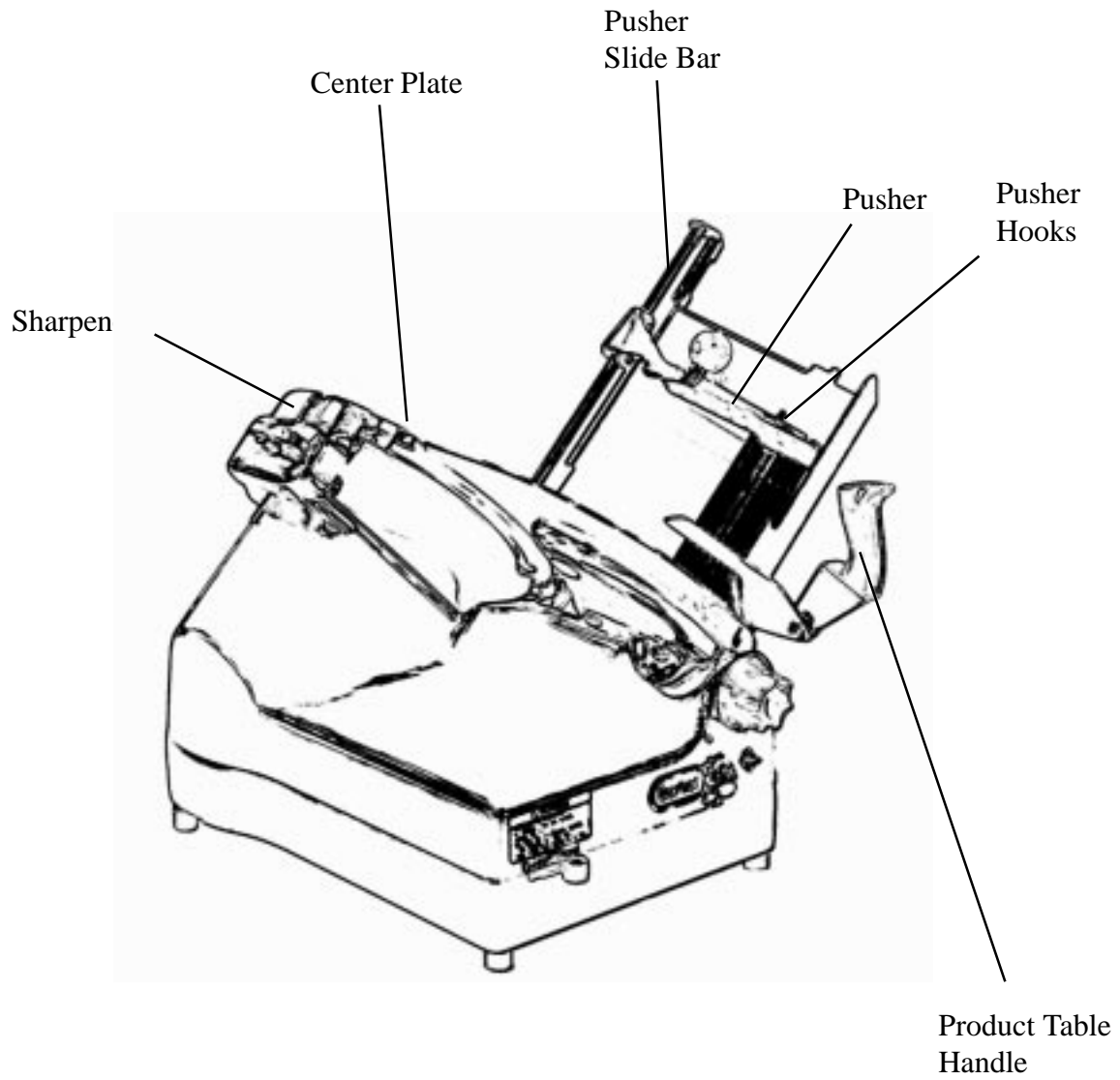

EQUIPMENT DESCRIPTION

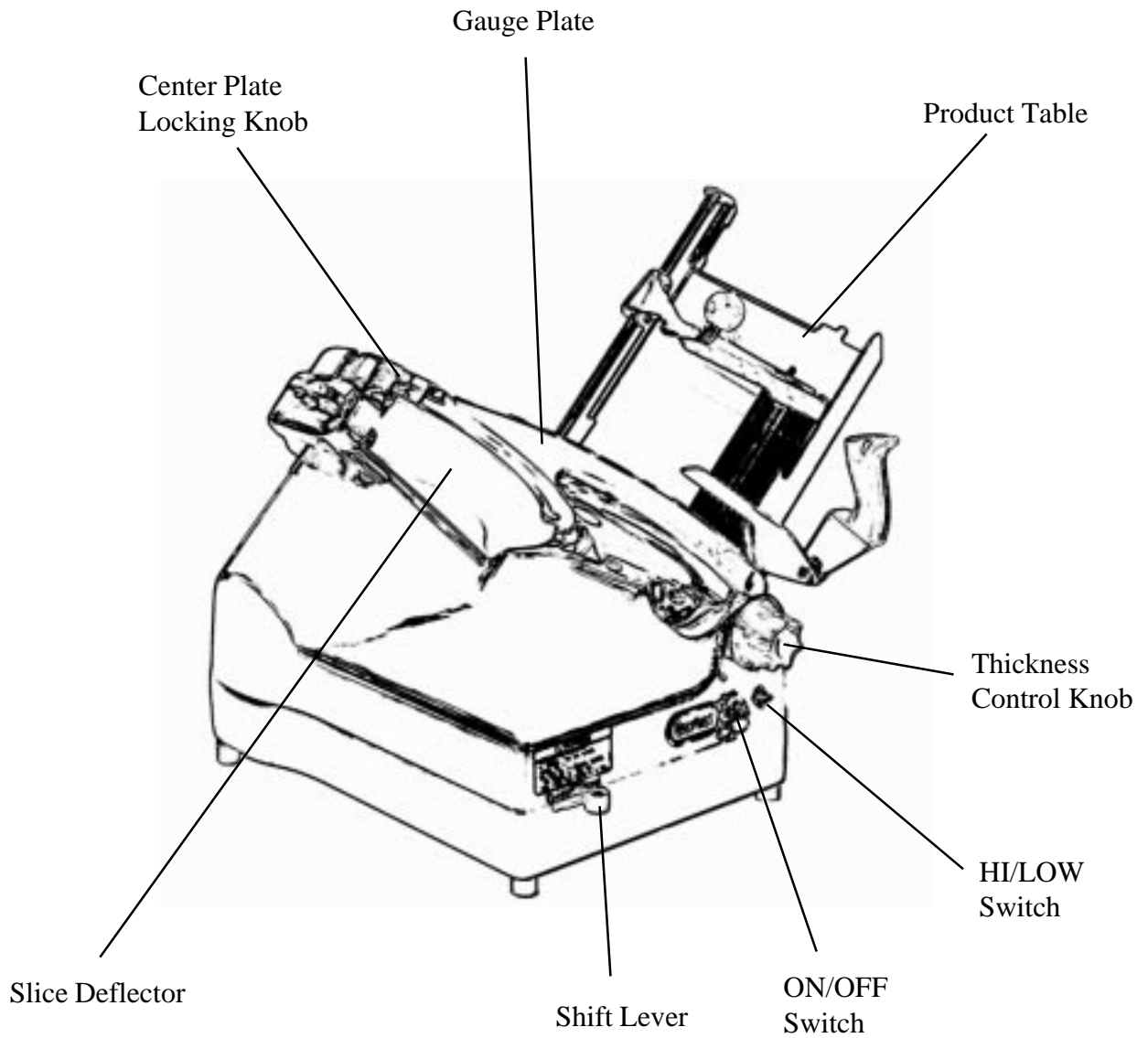

INSTALLATION

GENERAL

SAFE OPERATION REQUIRES PROPER
INSTALLATION AND PROPER WORK AREA.

1. Slicer should be installed in an area having adequate lighting.
2. Operator should have adequate space to move freely in the work area.

MACHINE MUST BE INSTALLED AND
OPERATED ON SOLID, LEVEL SUPPORT.

3. Installation should be made by an authorized Designated Berkel Service Location who will demonstrate the slicer and register it for warranty.

NEVER TRY TO BYPASS SWITCHES
AND CIRCUITS PROVIDED.
DO NOT ACTIVATE BY WALL SWITCH.

4. After assembly, check to see that the following labels are in place on the slicer:
 - a. Warning label by power switch, part number [3175-00755](#).
 - b. Warning label on the front left corner of the housing, part number 3175-00650.
 - c. Warning label on the product table support arm, part number 3175-00767.
 - d. On the 919A, warning label on the sharpener cover, part number 3175-00768.
5. Post the Warning Wall Charts provided in a conspicuous place in the work area. They are part numbers 3175-00557 and [3175-00541](#).

NEVER OPERATE ANY SLICER
WITHOUT THE LABELS IN PLACE.

INSTALLATION – MODEL 909A

1. Inspect to ensure all parts have been provided and the center plate knife guard is in place.
2. Place the slicer into position where it will be used.

INSTALLATION – MODEL 919A

1. Inspect to ensure all parts have been provided and the center plate knife guard is in place.

NSF regulations require the Model 919A slicer to be mounted on 4” legs or be equipped with the optional Sure-Lock® lift. If your slicer is equipped with the optional Sure-Lock® lift, then proceed to the “Assembly” section.

2. Tip the slicer onto a thick pad of cloth.
3. Remove one of the short shipping legs and replace with one of the 4” legs. Tighten and install a rubber foot.

⚠ CAUTION

Never have more than one leg loose at a time.

4. Once one 4” leg is in place, proceed to install the other three legs, ONE AT A TIME. Make sure to put a rubber foot on each leg.
5. When all four 4” legs are installed, get assistance from another person to lift and position the machine where it will be used.

⚠ CAUTION

Do not set slicer upright by pulling it forward on two legs.
You may break one or both of the 4” legs.

ASSEMBLY

GENERAL

1. To assemble the product table on the slicer:
 - a. The gauge plate must be completely closed before the table can be installed.
 - b. The support arm must be in the home, or fully forward position to mount the product table.
 - c. Since the pusher can slide or rotate, KEEP THE SLICING TABLE LEVEL.
 - d. Loosen the locking knob but do not remove.
 - e. Hold the slicing table with both hands and lower it carefully into the slot of the support arm until it is against the stop.
 - f. Tighten the locking knob.
2. To release the product pusher from the end of the product table:
 - a. Grasp the product pusher knob.
 - b. Pull the pusher gently up toward the upper end of the product table and lift free from the stop.
 - c. Lower the pusher gently until it rests at the bottom of the product table.
3. Put a few drops of the sample Berkel USDA-authorized food machine oil supplied with the slicer on the product pusher slide bar.

⚠ WARNING

USE ONLY USDA-AUTHORIZED OIL ON THIS MACHINE.
NON USDA-AUTHORIZED OIL MAY CONTAMINATE MACHINE
AND CAUSE FOOD POISONING AND PERSONAL INJURY.

4. USDA authorized Berkel oil is available in 2-oz (P/N 4675-00182), 16-oz (P/N 4675-00183) and one-gallon (P/N 4675-00184) containers.
5. To store the pusher at the top of the product table, simply pull the product pusher to the top of the table and allow the nylon button to fall behind the catch plate at the top of the product table.

TESTING PRIOR TO OPERATION

⚠ WARNING
SHARP KNIFE

TO AVOID SERIOUS PERSONAL INJURY:

1. NEVER touch rotating knife.
2. Keep HANDS CLEAR of all MOVING PARTS. Use PRODUCT TABLE HANDLE—not your hand.
3. Always TURN OFF slicer when NOT IN USE.
4. Always TURN thickness control knob as far to the right as possible when NOT IN USE.
5. TURN OFF and UNPLUG machine before CLEANING or SERVICING.

GENERAL

1. Make sure the machine is unplugged.
2. Check to see that the center plate, product table and sharpener assembly are in proper position.
3. Turn thickness control knob as far to the right as possible. This positions the gauge plate so that the knife is not exposed during testing.
4. Plug the power cord into a GROUNDED, APPROVED electrical outlet, using the plug that is provided with the machine. The pilot light should be solid and constant. If it is blinking, then one of the following conditions applies:

- One blink - The center plate is not installed properly.
- Two blinks - The meat table is not installed properly.
- Three blinks - If the slicer has a lift, then the lift is not completely down.
- Four blinks - The motor overload sensor has been tripped.

If you cannot satisfy the condition causing the blinking light, then call you nearest Designated Berkel Service Location.

MANUAL OPERATION

Note: Make sure on the Model 919A slicers that the shift lever is in the manual position.

1. Turn the unit on by pushing the START switch up, then release so that it goes back to the middle position. The knife will start slowly, then speed up.



2. Using the product table handle, slide the table back and forth. If there is any rough operation or obstruction, shut the machine off, unplug the power cord, and call your nearest Designated Berkel Service Location, which can be found at www.berkel.com.
3. Allow the slicer to run for 15 seconds without moving the table. The slicer should automatically turn off after 15 seconds of non-movement of the product table. If not, call your nearest Designated Berkel Service Location.

AUTOMATIC OPERATION

1. See General Section on Page 8.
2. With the unit OFF, push shift lever toward AUTO with left hand while sliding the product table handle with the right hand until you feel it engage.
3. Remove your right hand from the product table handle.
4. Select LO speed by switching the speed selection switch to the DOWN position.



5. Start the machine. The slicer will now slice approximately 40 slices per minute. Select HI speed by switching the speed selector switch to the UPPER position. The slicer will now slice approximately 60 slices per minute.
6. Turn the slicer OFF after testing by pushing the start/stop switch down and then pushing the shift lever to the MANUAL position.

THE SLICER WILL STOP WHEN SHIFTED FROM “LO” TO “HI” OR “HI” TO “LO” WHILE THE SLICER IS RUNNING. IT WILL BE NECESSARY TO RESTART THE SLICER WHEN SWITCHING BETWEEN SPEEDS. WHEN SHIFTING, THE KNIFE SPEED WILL INCREASE (OR DECREASE) AS WELL AS THE PRODUCT TABLE.

OPERATING INSTRUCTIONS

⚠ WARNING
SHARP KNIFE

TO AVOID SERIOUS PERSONAL INJURY:

1. NEVER touch rotating knife.
2. Keep HANDS CLEAR of all MOVING PARTS. Use PRODUCT TABLE HANDLE—not your hand.
3. Always TURN OFF slicer when NOT IN USE.
4. Always TURN thickness control knob as far to the right as possible when NOT IN USE.
5. TURN OFF and UNPLUG machine before CLEANING or SERVICING.

GENERAL

1. Place the product to be sliced on the product table. Release the product pusher from its stored position at the end of the product table and position at the end of the product. If the product is too long, place the pusher on top of the product and use the hook on the pusher to hold the product in place. The pusher will automatically feed the product toward the knife after every slice. On the 919A, move the fence until it fits loosely against the edge of the product. Tighten the knob.

⚠ WARNING

NEVER PUSH THE PRODUCT TOWARD
THE KNIFE WITH YOUR HAND.

2. The product table handle is used to move the product table during manual operation. DO NOT TOUCH any other part of the slicer or the product while you are slicing.

THICKNESS ADJUSTMENT

Note: If the thickness knob is closed, then the slicer must be turned on before the thickness knob can be turned.

1. Thickness adjustment allows you to vary the thickness of the slices from paper thin to more than 3/4 of an inch. To make thinner slices, turn the thickness control knob to the right. For thicker slices, turn the knob to the left.
2. The numbers on the knob will help you set the slicer to the thickness that's "just right" for a product. The numbers and thickness may vary slightly from one machine to the next. If you're slicing meat or cheese for customers, you can ask them how thick they want it, and adjust the slicer to meet their request.
3. Select either "LO" speed for soft products such as American cheese or Braunschweiger, or "HI" speed for firm products such as hard salami.
4. For manual operation, switch slicer ON and grasp the product table handle, moving the table back and forth.
5. LET SLICES DROP FROM THE KNIFE. The shape of the blade will cause slices to fall from the knife.

AUTOMATIC OPERATION—MODEL 919A

1. The shift lever is used on the automatic model only.
2. Before engaging the shift lever, the slicer should be turned OFF.
3. To engage the automatic slicer drive, move and HOLD the shift lever toward automatic with the left hand while manually moving the slicing table handle with the right hand until it locks in place.
4. Select either "LO" or "HI" speed by switching the speed selection switch. Select the downward position for "LO" for soft products such as American cheese or Braunschweiger, or the upper position for "HI" for firm products such as hard salami.



5. Turn slicer ON with RIGHT hand only after product is positioned.
6. LET SLICES DROP FROM THE KNIFE. The shape will cause slices to fall from the knife.

⚠ WARNING

AFTER EACH USE OF THE SLICER, TURN THE THICKNESS CONTROL KNOB FULL RIGHT. THIS PLACES THE GAUGE PLATE IN THE CLOSED POSITION AND COVERS THE KNIFE EDGE.

SHARPENER MAINTENANCE

⚠ WARNING

SHARP KNIFE

TO AVOID SERIOUS PERSONAL INJURY:

1. NEVER touch rotating knife.
2. Always TURN OFF slicer when NOT IN USE.
3. Always TURN thickness control knob as far to the right as possible when NOT IN USE.
4. TURN OFF and UNPLUG machine before CLEANING or SERVICING.

DIRTY STONES CANNOT SHARPEN!!!!

If the sharpening stones have become coated with food fats because of failure to clean the knife before sharpening, they should be cleaned or replaced. Coated and dirty stones will never sharpen effectively.

1. To remove the sharpener, grasp the top handle with the left hand and lift from the slicer.

⚠ WARNING

THE NEXT STEPS WILL EXPOSE THE KNIFE.

2. Unscrew the sharpener cover locking knob. The sharpener and its cover will come apart. Clean the cover with water and detergent. Carefully clean around the stones.
3. Check the stones. If they do not turn freely, the sharpener stone shafts must be cleaned and oiled (use Berkel USDA-authorized oil, P/N 4675-00182). If the stones are dirty and coated with food fats, they should be cleaned or replaced.
4. Oil sharpener shafts. Place a few drops of Berkel oil on each shaft. Move the sharpening lever back and forth to make sure that the stones move in and out easily. Oil mounting post.

TO REPLACE THE SHARPENING STONES:

1. Remove the stones from the shaft by using a 10-millimeter metric wrench while gripping the stone firmly with the left hand.

NOTE: The sharpening stone (cup shaped) is mounted on a left-hand threaded shaft. Turn the nut to the right to remove. The deburring stone (cone shaped) is mounted on a standard right-hand threaded shaft. Turn nut counterclockwise to remove. Always use a nut and washer to secure the stones to the shaft.

2. Assemble sharpener with new stones. Make sure that the sharpener fits into the two guide pins inside its cover and tighten the sharpener cover locking knob.
3. Replace sharpener. Sharpener must be all the way down, protecting the top of the knife.

TO CLEAN THE SHARPENING STONES:

1. Place the stones in a solution of soap and water and allow to soak for approximately one hour.
2. Remove the stones from the solution and brush clean with a stiff bristle brush (Berkel P/N 4975-09237).
3. Rinse the stones with water and dab with a paper towel to remove excess moisture.
4. Allow stones to air dry until the next day.

NOTE: Ensure the stones are completely dry before using them. If stones have chips, cracks, or metallic buildup that can't be cleaned, discard them.

CLEANING AND SANITIZING

⚠ WARNING

THE SHARP KNIFE IS EXPOSED DURING SEVERAL CLEANING STEPS.

TO AVOID SERIOUS PERSONAL INJURY:

1. Make sure the slicer is OFF.
2. UNPLUG slicer from outlet.
3. TURN thickness control knob all the way to the RIGHT to close the gauge plate.
4. Place PUSHER in its STORED and locked position.
5. Use ONLY recommended cleaning equipment and materials.

DISASSEMBLY FOR CLEANING

1. Turn off and unplug the slicer from the wall outlet.
2. Slide product table toward you.
3. Turn the thickness control knob fully to the right. The gauge plate must be completely closed and the arm fully forward before the table can be removed.
4. Loosen the product table locking knob.
5. Hold the product table and lift off. Since the pusher can slide or rotate, keep slicing table level.
6. Lift the locking knob on the center plate, hold with both hands and lift off the positioning pin.



7. Remove the sharpener. Loosen the sharpener knob and separate the cover from the sharpener.
8. Push the slice deflector lower hinge tab down with the left hand while holding up on the slice deflector until the lower deflector pin clears the lower hinge. Pull the deflector out at the bottom and down to release top pin, then lift deflector free.
9. Clean and sanitize removed parts. Berkel recommends using USDA-approved sanitizer (P/N 4975-00400). Wash these parts in hot water with detergent or put parts through dishwasher, rinse in hot water and rinse again in sanitizing solution. Let the parts air dry.
10. Reinstall the sharpener cover/top guard assembly.
11. Clean the slicer base using a cloth and cleaning solution. Rinse with hot water.

 CAUTION
TO AVOID MACHINE DAMAGE, DO NOT WASH MACHINE WITH HIGH PRESSURE WATER OR STEAM.
<ul style="list-style-type: none">• DO NOT use steel wool or steel wool type soap pads on the knife!• DO NOT allow any food particles to remain on the knife.• DO NOT use any other knife or metal objects to scrape stubborn deposits of sliced product from knife.• DO NOT leave the knife uncleaned for long periods of time. Clean AT LEAST once a day.

CLEANING THE KNIFE



The stainless steel knife will corrode if not properly cleaned and maintained. To properly clean the knife:

1. Make sure thickness control knob is as far to the right as possible.
2. Clean front side of knife using wet sponge or wet towel. To avoid contact with cutting edge, WIPE FROM CENTER TO OUTER EDGE. Turn the knife from the backside with left hand.
3. Clean backside of knife. Rotate knife downward with sponge or towel. Then wipe with upward motion. Repeat until clean.
4. CLEAN TOP OF GAUGE PLATE ONLY WHEN IT IS IN THE CLOSED POSITION. Using a wet sponge or wet cleaning towel, wipe the gauge plate always AWAY FROM THE KNIFE.
5. Clean the knife box ONLY with the cleaning brush supplied with the machine.
6. Clean the back of the knife box area with the cleaning brush.
7. Rinse with clean water, sanitize and allow to dry. Berkel recommends using USDA-approved sanitizer (P/N 4975-00400).

REASSEMBLY

1. Reassemble removable parts that have been cleaned and sanitized.
2. Grasp center plate with left hand on top knob and right hand on the bottom. Align elongated hole onto stationary pin. Bring plate forward, align center plate locating holes with knife guard locating pins. With left hand, raise locking knob and lower center plate into place. Release locking knob.
3. Replace slice deflector. Hook the top pin first, then push down slightly on the lower hinge tab and hook the bottom locking pin. Snap closed.

NOTE: If knife is dull, sharpen knife per procedure on Page 17.

4. Replace product table. The product support arm must be fully forward before the table can be installed. Hold the product table with both hands and carefully lower it in place.
5. Tighten the locking knob.
6. Oil pusher shaft. Move the pusher up and down and coat the rod with a thin film of Berkel USDA-authorized oil.

⚠ WARNING

TO PREVENT PRODUCT CONTAMINATION,
USE ONLY USDA-AUTHORIZED OIL (P/N4975-00182).

SANITIZING

1. After cleaning, the slicer **MUST BE SANITIZED** to kill germs and bacteria.
2. Use only an **APPROVED SANITIZING SOLUTION**.
3. Sanitize slicer. Spray with sanitizing solution and air dry.

SHARPENING

GENERAL

1. The knife should be sharpened at least once a day when the slicer is cleaned and sanitized.
2. You should also sharpen the knife whenever you notice wavy slices or excess scrap.
3. The knife must be cleaned before sharpening. See Page 15.

⚠ WARNING

TO AVOID SERIOUS INJURY, KEEP HANDS AWAY FROM
BLADE. SHARPEN 919A ONLY IN THE MANUAL POSITION.

SHARPENING INSTRUCTIONS

1. Make sure the slicer is **OFF**.
2. Set shift lever to **MANUAL** on Model 919A Automatic Slicer.
3. Turn thickness control knob all the way to right to close the gauge plate.
4. Slide the product table toward you.
5. Loosen the product table locking knob.
6. Remove product table. Since the pusher can slide or rotate, keep product table level.

7. Lift the sharpener with left hand and rotate into sharpening position and lower with ONE STONE on each side of the blade.
8. Place your left thumb on the sharpener cover for control, and pull the sharpening lever with your left index finger until it stops.
9. Turn slicer ON with right hand. Hold lever for approximately 5 to 10 seconds. Use moderate pressure. Release the sharpener lever.

Note: The slicer will automatically shut off after 15 seconds, since the table is not moving. If it is necessary to sharpen for more than 15 seconds, you can restart the slicer.

10. Turn the slicer OFF with right hand.
11. Return sharpener to storage position.
12. After sharpening, clean and sanitize slicer as described on Pages 14 through 16.

OPTIONAL ACCESSORIES

VEGETABLE CHUTE (4975-00370)

A vegetable chute is available to replace the slicing table. To install the vegetable chute, loosen the slicing table locking knob and remove the slicing table. Loosen the locking knob on the vegetable chute and fit it to the machine the same way as the slicing table. Tighten locking knob. Before operating, check to see that there is approximately $\frac{1}{16}$ " clearance between the end of the vegetable chute and the gauge plate with the index knob set at "0."

The vegetable chute is used for quantity slicing of various size fruit, meats or vegetables.

PRODUCT FENCE (4975-0004) & SKEWER ASSEMBLY (4975-00005)

The fence and product skewer are designed to fit on the upper edge of the slicing table.

To attach the product skewer and fence, loosen the locking knob. Position the slot in the end casting so it can be slipped up and over the lip at the front upper edge of the slicing table. Position the fence and product skewer so there is enough space for the product to slide down easily. Tighten locking knobs. Supplied with each skewer assembly is a coring tool. This tool is used to cut a hole through the core of the product before inserting the product skewer.

The product fence and skewer assemblies are used for uniform crosscut on tomatoes, onions, peppers and similar round products.

TRAYS

RECEIVING TRAY (3875-00059)

The receiving tray is a shallow-lipped tray to receive the product and hold small quantities of juices (hot beef, tomatoes, etc.) The tray is contour molded to the receiving area of the machine to hold it steady during operation.

SLAW TRAY (3875-00031)

The slaw tray is a deep tray to receive a large quantity of product and retain the juices.

Both the receiving and slaw trays are made of heavy duty plastic that meet standards for sanitation and are machine washable.

JUICE CUP (3875-00001)

The juice cup is designed to fit onto the back lip at the receiving area of the slicer where it will catch the juice (tomatoes, for example) while allowing the product to drop freely on the receiving area.

TROUBLESHOOTING

If your slicer should fail to function, here are a few things you can check before calling a serviceman.

KNIFE NOT SHARPENING

1. Are sharpening procedures being followed exactly as shown in this manual?
2. Are sharpener stones clean? If not, replace them according to the instructions given in the Sharpener Maintenance section. See Page 12.
3. Are sharpening stones severely worn and not making contact with the blade? If so, replace them according to instruction given in Sharpener Maintenance section. See Page 13.
4. Are sharpener stones in good condition but not making solid contact with the knife? If so, have your Berkel serviceman adjust them to the proper height.
5. Is knife blade clean? If coated with food fats, sharpener stones cannot sharpen. Clean per instructions.

ELECTRICAL FAILURE

1. Is slicer fully plugged into wall receptacle? If properly connected, the red pilot light should be illuminated.
2. Is the pilot light blinking? If so, then correct the fault listed below:
 - One blink - The center plate is not installed properly.
 - Two blinks - The meat table is not installed properly.
 - Three blinks- If the slicer has a lift, then the lift is not completely down.
 - Four blinks - The motor overload sensor has been tripped.

3. Inspect the power cord? Has it been damaged, cutting off electrical flow?
4. Are you getting electricity from wall outlet? Check by plugging in another piece of equipment with the same electrical requirements. Also, check the circuit breaker or fuse.

If you are getting electrical power, and your slicer is still not operating properly, contact your Designated Berkel Service Location.

INDEXING MECHANISM NOT ADVANCING GAUGE PLATE

1. Is the product table properly attached to the support arm? If not, the gauge plate can not be opened.
2. Is the slicer running. You will not be able to open the gauge plate until the slicer is running.

If the indexing knob should not open and close the gauge plate properly, it is a sign that the internal mechanism has suffered some loss of adjustment. Do not try to adjust the mechanism yourself. Contact your Designated Berkel Service Location.

AUTOMATIC/MANUAL SELECTOR NOT ENGAGING (919A MODEL)

This should be checked only by your Designated Berkel Service Location.

NOTE: The mechanism in the undercarriage should not be oiled or greased except by a Designated Berkel Service Location. Excess oil can lead to wear, breakage and slippage of the drive belt and cause you needless expense.

REPAIR PARTS/REPAIR SERVICE

Please contact your Designated Berkel Service Location (DBSL) for any repair parts and/or repair service required on your Berkel slicer. Your nearest DBSL can be found on the web at www.berkel.com. Additional information may be obtained from:

Service Support Center
Berkel Company
4406 Technology Drive
South Bend, Indiana 46628
(574) 232-8222
(800) 348-0251

SPECIFICATIONS

DIAMETER OF KNIFE:	12 ¹ / ₂ " (318 mm)
SLICE THICKNESS:	up to 27/32" (21 mm)
KNIFE SPEED:	400 rpm high/265 rpm low
SLICING SPEED: (919A ONLY)	60 spm high/40 spm low

SLICING CAPACITY:	
<i>Square</i>	11" x 6" (280 mm x 152 mm)
<i>Round</i>	8" (203 mm)

	919A	909A
MACHINE DIMENSIONS:		
<i>Height</i>	24" (610 mm)	20" (533 mm)
<i>Width</i>	20" (508 mm)	20" (508 mm)
<i>Depth</i>	29" (737 mm)	29" (737 mm)
Add 3" (76 mm) for NSF legs		

	919A	909A
NET WEIGHT:	114 lbs (52 kg)	90 lbs (41 kg)

	919A	909A
SHIPPING WEIGHT:	160 lbs (73 kg)	120 lbs (55 kg)

VOLTAGE/AMPERAGE:	115/60/1; 5.5/4.5 amp; 1/2 hp
--------------------------	-------------------------------



The Choice of Experience

Warranty

Effective: February 14, 2002

Berkel Company (“Berkel”) warrants to the Buyer of new equipment that said equipment, when installed in accordance with our instructions and subjected to normal use, is free from defects in material or workmanship for a period of one (1) year from the date of sale.¹

BERKEL SPECIFICALLY DISCLAIMS ANY IMPLIED WARRANTY OF MERCHANTABILITY OR EXPRESS OR IMPLIED WARRANTY OF FITNESS FOR A PARTICULAR PURPOSE.

Berkel’s obligation and liability under this warranty is expressly limited to repairing or replacing equipment that proves to be defective in material or workmanship within the applicable warranty period. Berkel or a Designated Berkel Service Location will perform all repairs pursuant to this warranty. Berkel expressly excludes responsibility for incidental or consequential damages to buyer or any third party, including, without limitation, damages arising from personal injuries, lost profits, loss of business opportunity, loss of property, economic losses, or statutory or exemplary damages, whether in negligence, warranty, strict liability or otherwise.

This warranty does not apply to: periodic maintenance of equipment including but not limited to lubrication, replacement of worn blades, knives, stones, knobs, accessories, and miscellaneous expendable supply items, and other adjustments required due to installation set-up or normal wear.

These warranties are given only to the first purchaser from a Berkel Authorized Channel of Distribution. No warranty is given to subsequent transferees.

The foregoing warranty provisions are a complete and exclusive statement of the warranty between the buyer and seller. Berkel neither assumes nor authorizes any persons to assume any other obligation or liability connection with said equipment. This warranty supersedes any and all prior warranties to the subject hereof.

¹ Model 180 slicers carry a 90-day warranty.