

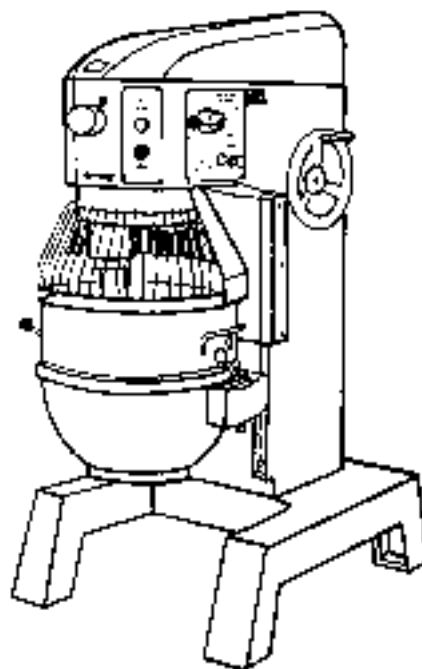

OWNER/OPERATOR MANUAL



MODELS PM60 & PM80 MIXERS

NOTICIA IMPORTANTE

Este manual contiene importantes instrucciones de seguridad que deben ser seguidas al pie de la letra cuando utilice esta maquina.

IMPORTANT NOTICE

This manual contains Important Safety Instructions which must be strictly followed when using this equipment.

BEFORE USING THIS EQUIPMENT

Berkel's mixers are designed to mix bakery and deli type food products safely and efficiently. However, unless the operator is properly trained and supervised, there is the possibility of a serious injury. It is the responsibility of the owner to ensure that this mixer is used properly and safely, strictly following the instructions contained in this manual and any requirements of local law.

No one should use or service this mixer without proper training and supervision. All operators should be thoroughly familiar with the procedures contained in this manual. Even so, Berkel cannot anticipate every circumstance or environment in which its mixers will be used. You, the owner and operator, must remain alert to the hazards posed by the function of a mixer—particularly the rotating tools. No one under 18 years of age should operate this equipment. If you are uncertain about a particular task, ask your supervisor.

This manual contains a number of safe practices in the General Safety Instruction Section. Additional warnings are placed throughout this manual. **WARNINGS RELATED TO YOUR PERSONAL SAFETY ARE INDICATED BY:**

WARNING

If any warning label, wall chart or manual becomes misplaced, damaged or illegible, please contact your nearest distributor or Berkel directly, for a free replacement.

Remember, however, **THIS MANUAL OR THE WARNING LABELS DO NOT REPLACE THE NEED TO BE ALERT AND TO USE YOUR COMMON SENSE WHEN USING THIS MIXER.**

TABLE OF CONTENTS

	<i>Page</i>
General Safety Instructions	2-3
Equipment Description	4
The Basics	5
Installation	5
Operating Instructions	6
Product Suggestions	8
Bowl Accessories	10
Attachments	10
Taper Hub Attachments	11
Cleaning and Sanitizing	11
Troubleshooting	12
Repair Parts/Repair Service	12
Specifications	13
Capacity Chart	14
Warranty	15

The Berkel Company • World's Leading Manufacturer of Slicer and Food Processing Equipment

BERKEL COMPANY

4406 Technology Drive · South Bend, Indiana 46628-9700
574/232-8222 · Fax 574/232-8116
(800) 348-0251

▲ PELIGRO

CUCHILLA FILOSA

**Para evitar serios accidentes a su persona
siga las instrucciones de este manual**

y

1. **NUNCA** utilice esta maquina sin previa instruccion y autorizacion de su supervisor.
2. Apague y desconecte la maquina antes de limpiar, sanitizar, o arreglar.
3. **LA MÁQUINA DEBE** apoyarse sobre un nivel solido y plano.
4. **EN CASO** de que la maquina se trabe, apague y desconcte antes de sacar lo que la obstruye.
5. **SIEMPRE** apague la batidora antes de colocar los accesorios.
6. **UTILIZE** unicamente los repuestos provistos por el fabricante.
7. **MANTENGA** manos, brazos, cabello y ropa suelta **LEJOS** de toda parte en movimiento de la máquina.
8. **NUNCA** ponga las manos en el tazon cuando la batidora esta operando.
9. **NUNCA** toque los utensilios en rotacion.
10. El tapacubo debe estar en su lugar cuando los accesorios no se estan usando.
11. **EN CASO** de que los membretes de ‘**PELIGRO**’ se desprendan de la máquina o sean illegibles, llame al fabricante o a su representante de service Berkel para que lo reemplace sin cargo.

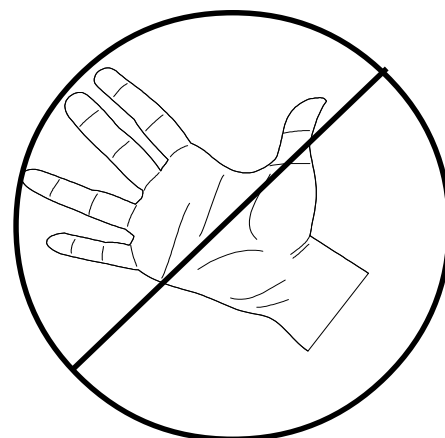

▲ WARNING

ROTATING TOOLS

**To avoid serious personal injury
follow all the instructions in this manual
and**

1. NEVER touch this machine without training and authorization by your supervisor.
2. TURN OFF AND UNPLUG machine before cleaning, sanitizing or servicing.
3. MACHINE MUST BE on solid level support.
4. SHOULD MACHINE JAM, turn off and unplug before removing obstruction.
5. ALWAYS turn off the mixer before fitting attachments and accessories.
6. USE ONLY the attachments and accessories provided by the manufacturer.
7. KEEP hands, arms, hair and loose clothing clear of all moving parts.
8. NEVER put hands in bowl when mixer is in operation.
9. Never touch rotating tools.
10. The attachment hubcap must be in place when the attachments are not being used.
11. SHOULD any warning label on a machine come off or become unreadable contact the manufacturer or your Designated Berkel Service Location for a free replacement.

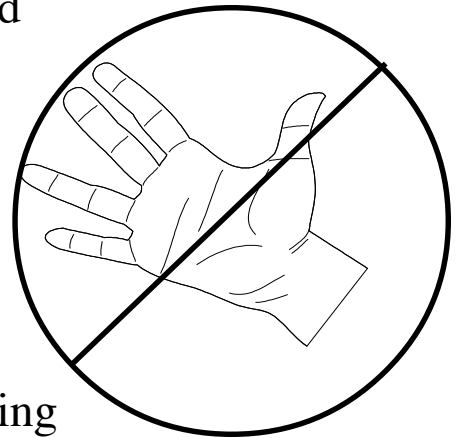

EQUIPMENT DESCRIPTION

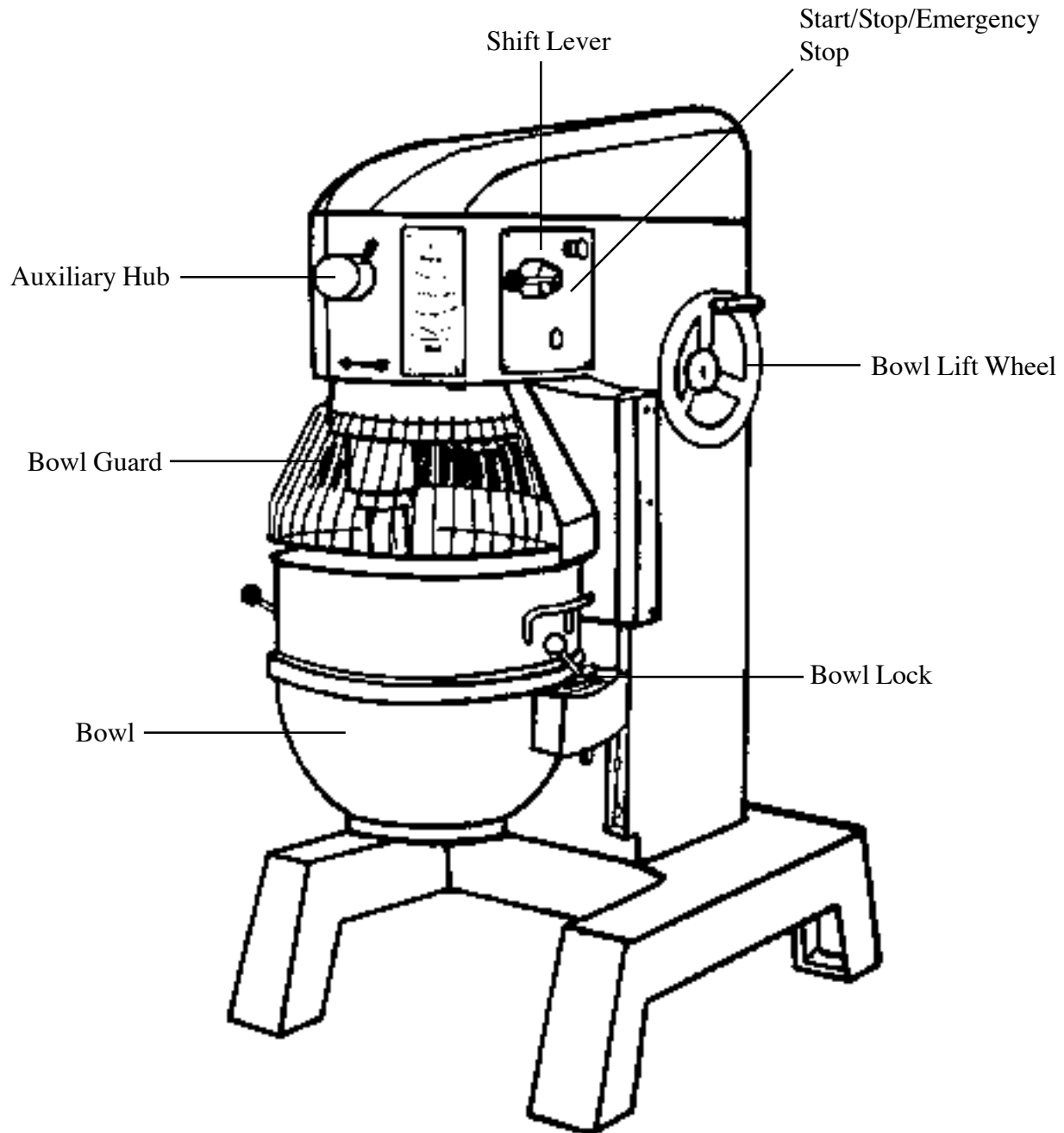

THE BASICS

The models PM60 and PM80 planetary mixers are designed for mixing doughs, cremes, potatoes, mixes, sauces and toppings. They have bowl guards, no-volt release, 99-minute timers and 3 or 6 fixed speeds. They come equipped with a #12 taper hub for accepting any #12 attachment. The optional VSPH can be used for slicing shredding and grating, while the FCMC can be used for chopping and grinding.

REVIEW THIS MANUAL COMPLETELY BEFORE USING YOUR MIXER.

INSTALLATION

SAFE OPERATION REQUIRES PROPER
INSTALLATION AND AN ADEQUATE WORK AREA.

General

1. Berkel suggests having an Authorized Berkel Service Technician install your mixer. A list of Designated Berkel Service Locations (DBSL) can be found at www.berkel.com. This technician will demonstrate the operation of the mixer.
2. Remove the wooden crating from around the mixer. Loosen and remove the 4 lag bolts (15/16" or 24mm) holding the mixer to the shipping skid.
3. Install the mixer in a well-lighted area with adequate, unobstructed space so the operator can move about freely. This location must also be solid and level.
4. Never by-pass the mixer's electrical switches or circuits. Never activate the mixer using a wall switch. A licensed electrician, according to local codes, should wire 220-volt mixers.



WARNING

To prevent the possibility of electrical shock, the mixer must be grounded.

5. Before attaching any accessories/attachments to the mixer, refer to the operating instructions on page 6 and turn on the mixer in low speed. Check that the rotation of the planetary matches the sticker on the front of the mixer. If the rotation does not match the sticker, then turn off immediately and contact a qualified electrician to check the wiring. The direction must match the label. Make sure the mixer is running smoothly with no obstruction.

6. Make sure the warning labels supplied with the mixer are in place. The warning labels are:
 - a. Read Owners Manual (3175-00755) above the start/stop switch on the right side of the machine
 - b. Keep Hands Clear (3175-00777) on the left side of the machine
7. Put the dough hook on the planetary and turn on the mixer in low speed. Check to see that there is clearance between the bowl and the dough hook at all times. The clearance between the dough hook and the bowl has been preset at the factory and should be approximately ¼”.
8. The gearbox in your mixer is permanently lubricated and will require no additional lubrication by the customer.

OPERATING INSTRUCTIONS

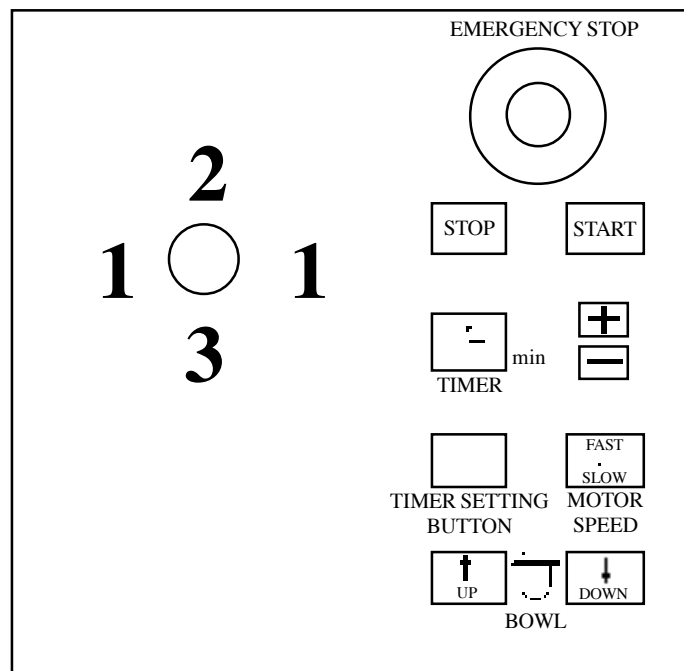

FOR MACHINES WITH POWER BOWL LIFT

1. Emergency Stop – Push in to stop the mixer. Twist so that it will pop back out before the mixer can be restarted.
2. Stop – Stops the mixer.
3. Start – Starts the mixer.
4. Timer – Shows the time in minutes that remain before the mixer will shut off.
5. + – Adds time to the timer.
6. - – Subtracts time from the timer.
7. Timer Setting Button – Turns the timer on or off, for timed or continuous mixing.
8. Motor Speed – On the 6 speed machines, toggles between the 3 low speeds to the 3 high speeds.
9. Up – On the power bowl lift machines, raised the bowl and cradle.
10. Down – On the power bowl lift machines, lowers the bowl and cradle.

FOR MACHINES WITHOUT POWER BOWL LIFT

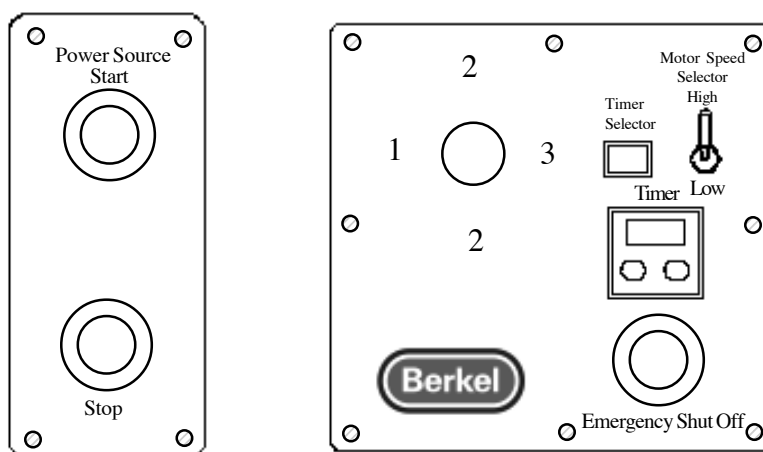

1. Emergency Stop – Push in to stop the mixer. Twist so that it will pop back out before the mixer can be restarted.
2. Stop – Stops the mixer.
3. Start – Starts the mixer.
4. Timer – Shows the time in minutes that remain before the mixer will shut off.
5. + – Adds time to the timer.
6. - – Subtracts time from the timer.
7. Timer Selector – Turns the timer on or off, for timed or continuous mixing.
8. Motor Speed Selector – On the 6 speed machines, toggles between the 3 low speeds to the 3 high speeds.

1. Rotate the bowl guard as far to the left as possible.
2. Lower the bowl yoke to its lowest position using the bowl lift wheel or the power bowl lift.
3. Install mixing bowl onto bowl yoke pins. Make sure the pin on the rear of the bowl properly engages with rear of bowl yoke. Rotate the two clips on the yoke to lock the bowl to the yoke.
4. Slip the desired attachment to the beater shaft and rotate to the left to lock it in place.
5. Refer to the capacity chart on page 14 and then fill the mixing bowl with the ingredients.
6. Raise the bowl to its fully up position. **The mixer will not start until the bowl is fully up.**
7. Rotate the bowl guard fully to the right. **The mixer will not start until the bowl guard is fully to the right.**
8. Your mixers are equipped with a 99-minute timer. If the mixing sequence is timed, then press the arrow keys until the desired time is displayed. If you want to run the machine continuously, then turn the timer off so that no display is shown. **The mixer will not start if the display is lit up, yet shows “0”.**
9. Put the mixer in position 1 (low speed) and press the start button. On the 3-speed machine there are 3 low speeds and on the 6-speed machine, there are three low speeds and three high speeds. The chart below shows the three or six speeds:

1st Low	40 rpm	1st High	80 rpm
2nd Low	66 rpm	2nd High	132 rpm
3rd Low	113 rpm	3rd High	226 rpm

SPEED SELECTIONS

SPEED	MIXTURES
Speed 1 (Low)	Heavy mixture (bread dough, heavy batters and potatoes)
Speed 2 (Medium)	Lighter mixtures (light dough, which must rise quickly, cake batters and some whipping operations)
Speed 3 (High)	Light work (shipping cream, beating eggs and mixing thin batters)

10. Check to see that there is clearance between the bowl and the dough hook at all times. The clearance between the dough hook and the bowl has been preset at the factory and should be approximately ¼". If not, then contact you nearest DBSL.
11. Your mixer is supplied with an electrical overload. The condition that caused the overload should be rectified before the mixer is restarted. Three signs that the motor may be overloaded are:
 - A. The attachment may rotate considerably slower.
 - B. The attachment does not rotate at a uniform speed.
 - C. The overload circuit breaker is popped out.

Overloading can be avoided by:

- A. Using the product capacity chart for recommended speeds and batch sizes.
- B. Selecting a slower speed.
- C. Reducing the ingredient batch size.

PRODUCT SUGGESTIONS

1. WHIPPING CREAM

The wire whip should be used for whipping cream. Cream to be whipped should be 24 hours old, should contain 30% butter fat and should be well chilled, in fact near freezing temperature is desirable, since the cooler the cream, the better the whipping. Warm cream may turn into butter instead of whipped cream. To prevent splashing out of the bowl, start whipping the cream at slow speed and increase the speed as the cream thickens.

2. EGG WHITES

Use the wire whip and be sure that the eggs are at room temperature and that both the mixing bowl and wire whip are free from all traces of fat or oil, or the egg whites won't whip. In some installations one bowl will be kept and used exclusively for beating egg whites. Another bowl will be used exclusively for the oily type mixes. Start beating the eggs at low speed and gradually increase the speed.

3. MERINGUES

Use the wire whip. Meringues can be made perfect by the gradual addition of sugar to eggs that have not been beaten too stiffly.

4. MAYONNAISE

Use the wire whip. Depending on the quantity of mayonnaise to be made, a commercially purchased 1 gallon, 2 gallon or 6 gallon oil dropper attachment should be used. This oil dropper attachment is attached to the mixer and automatically adds oil to the batch at a controlled rate of flow. Most mayonnaise recipes contain whole eggs, corn or cottonseed oil, vinegar, sugar, salt, mustard and white pepper. The eggs should be placed in the mixing bowl first and beaten for approximately five minutes at high speed. The speed should then be reduced to slow speed and add the dry ingredients that have already been mixed together. Mix at high speed for approximately five minutes. Then the oil dropper should be turned on so that the oil is gradually added to the batch for 10 to 20 minutes, after which time the vinegar is poured in slowly. The mixing should be discontinued after the vinegar has been thoroughly mixed into the batch. The last operation in making mayonnaise involves stopping the mixer, scraping the upper part of the bowl with a spatula or bowl scraper to make sure that every portion will be evenly mixed into the recipe. Mayonnaise becomes a thicker and more stable product when the oil is added very slowly.

5. MASHING POTATOES

Use the batter beater and pre-heat the bowl and beater. Start the operation on low speed. When the potatoes have been broken up, stop the mixer and add the milk or cream, butter and seasoning. Many operators like to change to the wire whip or to the four wing whip for whipping in the milk or cream since more of a whipping action is obtained to produce a fluffier mashed potato.

6. CAKE BATTERS AND COOKIE DOUGH

Use the batter beater. Butter or shortening can be thoroughly creamed in about 10 minutes. The butter or shortening should be at room temperature. Sugar should be added to recipes at a medium speed. When all of the sugar has been added, stop the mixer and scrape down the sides of the mixing bowl with a spatula, or bowl scraper, to insure a smooth mix. Be careful not to add sugar until the butter or shortening has been thoroughly creamed. Some recipes call for yolks and whites to be beaten separately. This is not necessary with your mixer, as the mechanical mixing is efficient enough to allow the addition of whole eggs. When adding dry ingredients, stop the mixer occasionally and scrape the upper part of the bowl with a spatula or bowl scraper to make sure that every portion will be efficiently mixed into the recipe. Always operate the mixer on slow speed while adding dry ingredients. Do most of the beating before the flour and milk are added. Over beating after addition of these two ingredients causes a sub-standard mixture.

7. MIXING DOUGH

Always use the dough hook for mixing heavy dough mixtures. Do not overload the mixer with batches that are too large. (See the capacity chart for capacities of the various size bowls.)

Remember - an increased mixing time means a decreased fermentation time. Weighing ingredients each time you mix will ensure a standard product. Stop the mixer occasionally to lower the dough mass from the hook and to scrape the bowl.

Important - In mixing heavy dough be sure to use the spiral dough hook, be sure not to overload the mixer (see the capacity chart), and be sure to start the mixer on low speed.

8. **BISCUIT MIX**

Use the wire whip. Mix shortening and dry ingredients until shortening is blended and mixture is granular in appearance. Turn off mixer. Scrape bowl down with bowl knife. Store in covered can until ready for use. (Use beater or dough hook when adding liquid; start mixing on slow speed. Do not over mix.)

BOWL ACCESSORIES

1. **Bowl Dollies** – This device is a low profile cart used for transporting a bowl that is loaded with product from one place to another.

ATTACHMENTS

1. **ALUMINUM SPIRAL DOUGH HOOK**

Used for mixing bread or roll dough of standard consistency, biscuits, meat loaf, etc. The aluminum spiral dough hook is a special dough hook for mixing heavy doughs such as white, graham or rye bread, noodles, pretzels, Italian bread and pizza. Dough hooks should always be operated at slow speed only. Do not use other types of beaters for dough work; doing so will result in damage to either the beaters or to the mixer itself. Never exceed capacities as listed.

2. **ALUMINUM BATTER BEATER**

Furnished as part of the standard equipment. Used for mixing batters such as cake and muffin batters, creaming butter, mashing potatoes and vegetables, light cakes, icings and the average run of light work. Never use this beater for heavy dough work. When mashing potatoes, etc., it is advisable to start with the bowl at its lowest position and then as the potatoes or other ingredients break up, the bowl should be gradually raised to its working position. This procedure eliminates severe strain to the beater and to the mixer proper and consequently adds to their life and efficiency.

3. **SS WIRE WHIP**

Used for whipping, creaming, beating eggs, meringues, small amounts of mayonnaise, icings, and for whipping milk or cream into mashed potatoes after they have been broken up with batter beater.

TAPER HUB ATTACHMENTS

The mixer has an attachment hub located on the front. A cover must be removed before the attachment can be set into place. Once in place, a locking knob secures the attachment to the mixer.

1. VSPH (4975-00103)

The VSPH (VEGETABLE SHREDDER PLATE HOLDER) vegetable cutter attachment provides fast cutting, grating and shredding of an abundant variety of food products. The high polished all aluminum housing features (5) available stainless steel plates for grating or shredding and an optional knife for cutting. Very helpful for volume cutting and grating for such products as lettuce, tomatoes, cheese, cabbage, carrots, cucumbers, etc. **The recommended speed would be low.**

2. FCMC (4975-00452)

The FCMC (FOOD CUTTER MIXER CHOPPER) is a grinder attachment used for small grinding processes. It is very durable and easy to clean. **The recommended speed would be low or medium, not high.**

CLEANING AND SANITIZING

The Models PM60 and PM80 mixers have been designed for a minimal amount of owner maintenance.

After use, thoroughly clean the bowl and attachments with hot soapy water. The mixer housing can be wiped down with a damp cloth. Rinse, sanitize and allow to air dry.

When sanitizing be sure to use only an approved sanitizing solution. This will help kill germs and bacteria.

If accessories have been used (example: VSPH) apply some Berkel USDA approved food equipment oil to the auxiliary drive socket and accessory shafts for lubrication.

WARNING

Use only USDA-authorized Berkel oil or grease to prevent possible food contamination. For your convenience, this oil is supplied in the following quantities: 2 oz. (part # 4675-00182), 16 oz. (part # 4675-00183), or one gallon (part # 4675-00184) containers. The grease is supplied in a pack of three 3-ounce tubes (part # 4675-00185).

TROUBLESHOOTING

If your mixer should fail to function, there are a few things you can check before calling a service technician. If you do need service, visit our web site at www.berkel.com. Pull down the service tab and click on your state. A list of the Designated Berkel Service Locations will be shown.

Motor will not operate when the start button is pushed

- The mixer is overloaded, activating the thermal overload switch. Correct the situation causing the overload by reducing the load or reducing mixing speed. See the product capacity chart on page 14.
- Set a time on the timer or turn the timer off.
- The bowl guard is not in place. Rotate the bowl guard fully to the right.
- The bowl is not fully up and in place. Lift the bowl to its fully up position.

Motor operates, but planetary does not turn in any of the speeds

- Internal drive or transmission linkage is inoperative. Contact your nearest Designated Berkel Service Location.

Hard to shift speeds

- Make sure the shift lever is fully engaged.

Mixer slips out of gear under load

- Make sure the shift lever is adequately engaged.

Product not being properly mixed at the bottom of the bowl

- Inadequate water to product ratio (AR)
- Excessive clearance at the bottom of the bowl and attachment. Contact your nearest Designated Berkel Service Location.

REPAIR PARTS/REPAIR SERVICE

Please contact your nearest Designated Berkel Service Location for any repair parts and/or repair service required on your Berkel slicer. A list of DBSL's can be found on the website at www.berkel.com. Pull down the service tab and then click on your start for the nearest DBSL.

Additional information may be obtained from:

Technical Service Support Center
Berkel Company
4406 Technology Drive
South Bend, IN 46628-9700
(574) 232-8222
(800) 348-0251

SPECIFICATIONS

		PM60	PM80
BOWL CAPACITY		60-qt. (63 l.)	80-qt. (84 l.)
DIMENSIONS	Height	63" (1600mm)	63" (1600mm)
	Width	32" (815 mm)	32" (815mm)
	Depth	44" (1120 mm)	44" (1120mm)
PLANETARY SPEEDS	1st (low)	18 rpm	18 rpm
	2nd (low)	27 rpm	27 rpm
	3rd (low)	50 rpm	50 rpm
	1st (high)	35 rpm	35 rpm
	2nd (high)	54 rpm	54 rpm
	3rd (high)	100 rpm	100 rpm
AUX. HUB SPEEDS	1st (low)	40 rpm	40 rpm
	2nd (low)	66 rpm	66 rpm
	3rd (low)	113 rpm	113 rpm
	1st (high)	80 rpm	80 rpm
	2nd (high)	132 rpm	132 rpm
	3rd (high)	226 rpm	226 rpm
NET WEIGHT		1017 lb. (462 kg)	1144 lb. (520 kg)
GROSS WEIGHT		1017 lb. (462 kg)	1144 lb. (520 kg)
VOLTAGE		220/60/3	220/60/3
HORSEPOWER		4 HP	5 HP
AMPS (START/RUN)		50/20 A	50/30 A

MIXING BOWL CAPACITY CHART

Bowl Capacity (Qt.)	10	20	30	40	60	80
Model	PM10	PM20	PM30	PM40	PM60	PM80
Motor (HP)	1/2	3/4	1	1.5	4	5
Small Bowls Available as Extras	-	10	20	30	30, 40	30, 40, 60
Overall Space Required (Floor)	14 X 18	15 X 22	24 X 25	24 X 25	32 X 44	32 X 44

KITCHEN MATERIALS CAPACITY CHART (FINISHED MATERIALS)

Egg Whites (Qt.)	1/2	1	1½	1½	2	2½
Mashed Potatoes (Lb.)	11	15	23	28	40	50
Mayonnaise (Qt. of Oil)	8	10	12	13	18	22
Meringue (Qty. of Water)	1/4	1½	1	1¼	2	3
Waffle or Hot Cake Batter (Qt.)	4	8	12	15	24	30
Whipped Cream (Qt.)	2	4	6	9	12	16

BAKE SHOP MATERIALS

Angel Food (8 - 10 oz. Cake) (Lb.)	7½	15	22	24	45	60
Box or Slab Cake (Lb.)	10	20	30	33	50	80
Cup Cakes (Doz.)	18	22	33	40	70	90
Layer Cake (Lb.)	16	20	30	34	60	80
Pound Cake (Lb.)	15	21	30	34	55	80
Pasta: Basic Egg Noodle (Lb.)	3	5	8	11	30	30
Sponge Cake Batter (Lb.)	6	12	18	22	36	54
Sugar Cookies (Doz.)	30	35	50	55	100	115
Bread/Roll Dough (Lb.)						
Light-Medium 60% AR @	10 *	25 *	45 *	50 +	75 +	80 +
Heavy 50% AR @	5 *	15 *	30 *	40 +	65 +	70 +
Pizza Dough (Lb.)						
Thin 40% AR @ ¢	4½ *	9 *	14 *	25 *	40 *	40 *
Med. 50% AR @ ¢7½ *	15 *	20 *	32 *	60 *	70 *	70 *
Thick 60% AR @ ¢	10 *	27 *	40 *	55 +	70 +	70 +
Whole Wheat Dough 70% AR	10	20	40	55	70	70
Pie Dough (Lb.)	12	18	27	30	50	60
Raised Doughnut Dough 65% AR	4½ +	9 +	15 +	17 +	30 #	40 #
Eggs & Sugar (For Sponge Cake)	4	8	12	13	24	36
Fondant Icing (Lb.)	6	12	18	20	36	45
Marshmallow Icing (Lb.)	1	2	3	3	5	6½
Shortening & Sugar, Creamed (Lb.)	8	15	24	26	48	55

@ If hi-gluten flour, reduce batch 10%

¢ 2nd speed, do not use at 50% AR or lower

* 1ST SPEED

+ 2ND SPEED

3RD SPEED

NOTE: Absorption ratio (% AR) = water weight divided by flour weight

Ex: Absorption ratio of a mixture containing 6 lbs. of flour and 3 lbs. of water $3\text{lbs}/6\text{lbs}=.50=50\%$ AR

Capacity depends on moisture content of dough

Above capacities based on 12% flour moisture at 70° water temperature

CAUTION:

IF HIGHER THAN RECOMMENDED SPEEDS ARE EMPLOYED AND/OR LISTED CAPACITIES ARE EXCEEDED, OVERLOAD CONDITION WILL RESULT.



The Choice of Experience

Warranty

Effective: February 14, 2002

Berkel Company (“Berkel”) warrants to the Buyer of new equipment that said equipment, when installed in accordance with our instructions and subjected to normal use, is free from defects in material or workmanship for a period of one (1) year from the date of sale.¹

BERKEL SPECIFICALLY DISCLAIMS ANY IMPLIED WARRANTY OF MERCHANTABILITY OR EXPRESS OR IMPLIED WARRANTY OF FITNESS FOR A PARTICULAR PURPOSE.

Berkel’s obligation and liability under this warranty is expressly limited to repairing or replacing equipment that proves to be defective in material or workmanship within the applicable warranty period. Berkel or a Designated Berkel Service Location will perform all repairs pursuant to this warranty. Berkel expressly excludes responsibility for incidental or consequential damages to buyer or any third party, including, without limitation, damages arising from personal injuries, lost profits, loss of business opportunity, loss of property, economic losses, or statutory or exemplary damages, whether in negligence, warranty, strict liability or otherwise.

This warranty does not apply to: periodic maintenance of equipment including but not limited to lubrication, replacement of worn blades, knives, stones, knobs, accessories, and miscellaneous expendable supply items, and other adjustments required due to installation set-up or normal wear.

These warranties are given only to the first purchaser from a Berkel Authorized Channel of Distribution. No warranty is given to subsequent transferees.

The foregoing warranty provisions are a complete and exclusive statement of the warranty between the buyer and seller. Berkel neither assumes nor authorizes any persons to assume any other obligation or liability connection with said equipment. This warranty supersedes any and all prior warranties to the subject hereof.

¹ Model 180 slicers carry a 90-day warranty.

