



BETTCHER Industries, Inc.

**Operating Instructions & Parts List for the
BB-1 115V, BB-1 115V CANADIAN
BB-2 115V, BB-1F 230V**



Manual# 103006

Issued: February 2, 2015

TMC# 801

Bettcher Industries, Inc.

6801 State Route 60

Birmingham, OH 44889 U.S.A.

Phone: (440) 965-4422

Fax: (440) 328-4535

Information in this document is subject to change without notice.

No part of this document may be reproduced or transmitted in any form or any means, electronic or mechanical, for any purpose, without the express written permission of Bettcher Industries Inc.

Written permission to reproduce in whole or part is herewith granted to the legal owners of the Optimax[®] with which these Operating Instructions have been supplied.

Operating Instructions in other languages are available on request. Additional copies of Operating Instructions are available by calling or writing your Regional Manager, or by contacting:

BETTCHER INDUSTRIES, INC.
6801 State Route 60
Birmingham, Ohio 44889
U.S.A.
Telephone: 440/965-4422
(In The U.S.A.): 800/321-8763
Fax: 440/328-4535

The Information Provided In These Operating Instructions Is
Important To Your Health, Comfort And Safety.

For Safe And Proper Operation, Read This Entire Manual
Before Using This Equipment.

<http://www.bettcher.com>



Copyright © 2015 By Bettcher Industries, Inc.
All Rights Reserved.
Original Instructions

Table of Contents

Section 1 *Safety and Ergonomics*

Section 2 *Designated Use*

Section 3 *Unpacking and Installation*

Section 4 *Instructions for Operation*

Section 5 *Maintenance*

Section 6 *Cleaning*

Section 7 *Service Parts*

Section 8 *Contact and Document Information*

Optimax[®]

Section 1

Safety and Ergonomics

CONTENTS OF THIS SECTION

Signal Word Panels	1-2
Safety Symbols	1-3
Safety Recommendations and Warnings	1-4
Ergonomic Features	1-6
Noise Level	1-6



The information provided in these operating instructions is important to your health, comfort and safety. For safe and proper operation, read this entire manual before using this equipment.



Please read and save these instructions. Read carefully before attempting to assemble, install, operate or maintain this product. Protect yourself, others and equipment by observing all safety information. Failure to comply with instructions could result in personal injury and/or damage to the equipment. Any use in applications other than those for which the equipment was designed and built may result in equipment damage and/or serious injuries.

Retain this manual for future reference. Be thoroughly familiar with the controls and proper use of this equipment.



SIGNAL WORD PANELS



Indicates a hazardous situation that, if not avoided, will result in death or serious injury.

(The signal word **DANGER** is in white letters on a safety red background)



Indicates a hazardous situation that, if not avoided, could result in death or serious injury.

(The signal word **WARNING** is in black letters on a safety orange background)



Indicates a hazardous situation that, if not avoided, could result in minor or moderate injury.

(The signal word **CAUTION** is in black letters on a safety yellow background)



Indicates information considered important, but not hazard-related (e.g. messages relating to property damage).

(The signal word **NOTICE** is in italicized, white letters on a safety blue background)

The signal word definitions provided, comply with the American National Standard for Product Safety Information in Product Manuals, Instructions, and Other Collateral Materials (ANSI Z535.6-2011).

This technical manual is printed in black and white.

SAFETY SYMBOLS



The safety alert symbol indicates a potential personal injury hazard. It is not used for messages related to property damage. The safety alert symbol may be used alone or in conjunction with a signal word in a signal word panel



Danger of electrical shock



Danger of Hand Entanglement - Drive Chain



Danger of Hand Entanglement - Roller Shaft



Read Operator's Manual



Two Person Lift

Symbols are harmonized with ANSI Z535.4 and ISO 3864-2 standards. Warning symbols are presented on a safety yellow background. Mandatory action symbols are presented on a safety blue background.

This technical manual is printed in black and white.



SAFETY RECOMMENDATIONS AND WARNINGS

WARNING

Labels must be in place and readable at all times. Bettcher Industries will replace any label that becomes unreadable, free of charge.

The manufacturer assumes no liability for any unauthorized changes in operating procedures or for unauthorized changes or modifications made to the design of the machine or any factory-installed safety equipment, whether these changes are made by the owner of this equipment, by his employees, or by service providers not previously approved by Bettcher Industries, Inc.

Use only replacement parts manufactured by Bettcher Industries, Inc. Use of substitute parts will void the warranty and may cause injury to operators and damage to equipment.

All maintenance procedures should be performed by qualified personnel.

WARNING

To avoid personal injury, guards must be in place while operating the machine.

Never operate without guards in place.



Moving machine parts and pinch points.
Never operate without discharge tray in place.

Sprocket and Chain

To avoid personal injury, guards must be in place while operating the machine.

WARNING

Never attempt to repair a wirebelt that has been previously repaired or has damage in more than one place. A belt with these properties could have small pieces break off into the product long before the next failure is noticed.

WARNING

To avoid personal injury, always disconnect the power cord before performing any adjustments, disassembly/assembly, troubleshooting or cleaning.



All electrical repairs should be completed by a qualified electrician or approved service provider.

SAFETY RECOMMENDATIONS AND WARNINGS (CONTINUED)

 **CAUTION**

Heavy lifting can cause injury. Use two-man lift.



Place frame assembly on a flat, level surface that can support 200 pounds.

 **CAUTION**

Do not over tighten screws in plastic components. Damage may occur.

 **CAUTION**

All sprockets must be in alignment with the wirebelting.

 **CAUTION**

Make sure wirebelt is installed in the proper direction.



SAFETY RECOMMENDATIONS AND WARNINGS (CONTINUED)

NOTICE

Make sure wirebelt is installed in the proper direction. If wirebelt edgeloop is installed improperly, damage to the wirebelt may result.

NOTICE

The recommended cleaning solution for the Optimax[®] Automatic Batter-Breader is eXtra[®] Heavy Duty Cleaner.



eXtra[®] Heavy Duty Cleaner, (PN:184332), is a concentrated cleaner and degreaser for food processing equipment. Contact Bettcher Industries, Inc. for details.

NOTICE

Do not machine wash drive guard covers or batter tanks. Excessive heat generated by machine washing can damage parts.

Do not submerge frame and motor assembly as damage to motor could result. Clean with damp cloth or sponge only.

ERGONOMIC FEATURES

The Optimax[®] Batter-Breading System eliminates manual application of batter and breading.

NOISE LEVEL

With normal use, the Optimax[®] noise emission value is less than 70 dB(a).

Section 2

Designated Use

CONTENTS OF THIS SECTION

Designated Use	2-1
Machine function	2-1
Machine Specifications - BB-1	2-2
Machine Specifications - BB-2	2-3
Machine Specifications - BB-1F	2-4

DESIGNATED USE

The Optimax[®] Automatic Batter-Breading machine provides the food service industry with a compact, economical and reliable batter-breading machine that consistently applies batter and/or breading to virtually all types of foods.

MACHINE FUNCTION

The Optimax[®] Automatic Batter-Breading machine applies a full range of batters and breadings to foods. Products are conveyed through the batter and then through the breading for an even, consistent coating.



MACHINE SPECIFICATIONS - BB-1

The Optimax[®] Batter-Breeding machine has been tested and meets the requirements of the National Sanitation Foundation (NSF), Intertek (ETL), and bears the official markings of these agencies.

Weight

	BB-1
Total Machine	116 lbs. (53kg)
Frame	67 lbs. (31 kg)
Breader Conveyor	38 lbs. (18 kg)
Batter Conveyor	9 lbs. (4 kg)
Batter Tank	2 lbs. (1 kg)

Overall Size

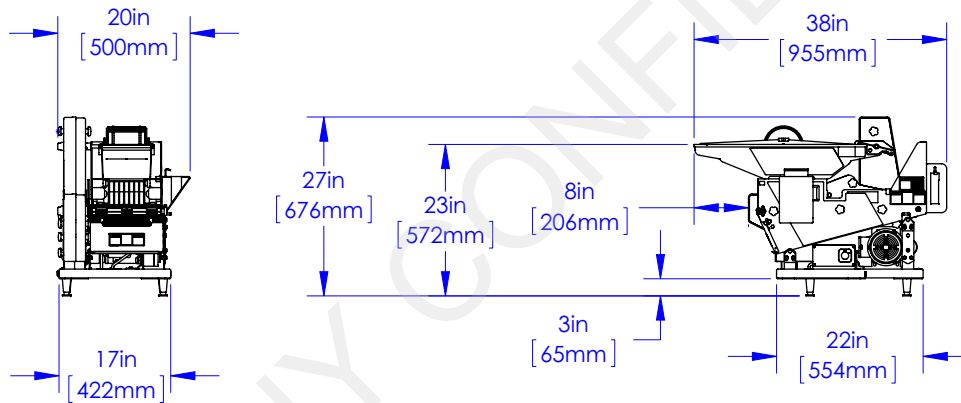

Speeds

Batter Conveyor	20 ft./min. (6.1 m/min)
Breading Conveyor	34 1/2 ft./min. (10.5 m/min)
Usable Belt Width	6 in. (152 mm)

Power Requirements

Power Source	115 VAC/ 1 Phase/ 60 Hz	2.4 A
--------------	-------------------------	-------

Capacity

Batter Capacity	6 qt. (5,7 l)
Breading Capacity	8-18 lbs. (3,6 to 8,1 Kg)

MACHINE SPECIFICATIONS - BB-2

The Optimax[®] Batter-Breading machine has been tested and meets the requirements of the National Sanitation Foundation (NSF), Intertek (ETL), and bears the official markings of these agencies.

Weight

	BB-2
Total Machine	181 lbs. (82kg)
Frame	81 lbs. (37 kg)
Breader Conveyor	38 lbs. (18 kg) x 2
Batter Conveyor	9 lbs. (4 kg) x 2
Batter Tank	2 lbs. (1 kg) x 2

Overall Size

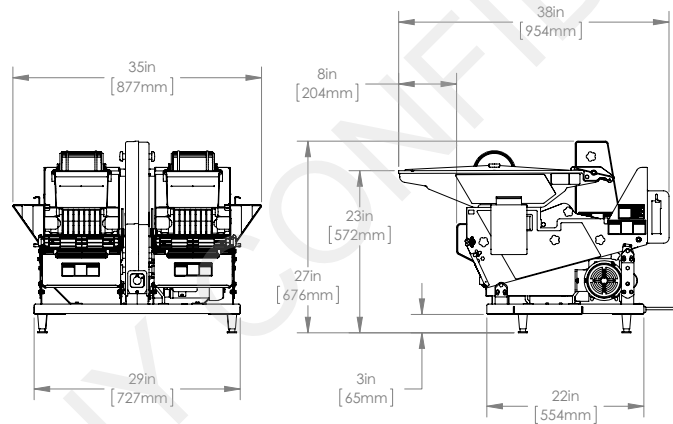

Speeds

Batter Conveyor	20 ft./min. (6.1 m/min)
Breading Conveyor	34 1/2 ft./min. (10.5 m/min)
Usable Belt Width	6 in. (152 mm)

Power Requirements

Power Source	115 VAC/ 1 Phase/ 60 Hz	2.4 A
--------------	-------------------------	-------

Capacity

Batter Capacity	6 qt. (5,7 l)
Breading Capacity	8-18 lbs. (3,6 to 8,1 Kg)



MACHINE SPECIFICATIONS - BB-1F

The Optimax[®] Batter-Breading machine has been tested and meets the requirements of the National Sanitation Foundation (NSF) and CE, and bears the official markings of these agencies.

Weight

	BB-1F
Total Machine	116 lbs. (53kg)
Frame	67 lbs. (31 kg)
Breader Conveyor	38 lbs. (18 kg)
Batter Conveyor	9 lbs. (4 kg)
Batter Tank	2 lbs. (1 kg)

Overall Size

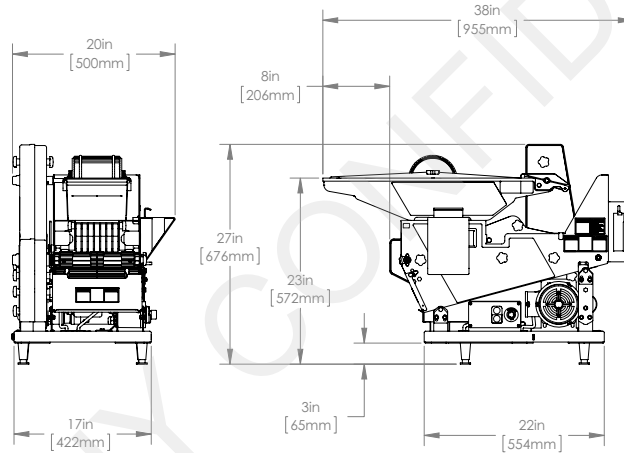

Speeds

Batter Conveyor	20 ft./min. (6.1 m/min)
Breading Conveyor	34 1/2 ft./min. (10.5 m/min)
Usable Belt Width	6 in. (152 mm)

Power Requirements

Power Source	230 VAC/ 1 Phase/ 50 Hz	1.39 A
--------------	-------------------------	--------

Capacity

Batter Capacity	6 qt. (5,7 l)
Breading Capacity	8-18 lbs. (3,6 to 8,1 Kg)

Section 3

Unpacking and Installation

CONTENTS OF THIS SECTION

Contents	3-2
Unpacking	3-3
Installation Instructions	3-6
Pre-operational Checkout	3-11

NOTE

BEFORE YOU BEGIN INSTALLATION

Check the contents of the box to make sure that all parts are included. If any items are missing, or you notice any damage, contact Bettcher Industries, Inc. at 1-800-321-8763 or contact your local distributor.

NOTE

In the event you have questions about the installation, use, care or service of this product, contact our customer service department at Bettcher Industries, Inc. at 1-800-321-8763 or contact your local distributor.

CONTENTS

Shown below are the typical contents found inside the shipping carton.



Batter Conveyor: Boxed individually, inside shipping carton.



Breader Conveyor: Installed on frame for shipping purposes.

UNPACKING

Step 1: Remove all components from the foam trays, packaging and shipping containers.



Bredder Conveyor Components and manual are shipped in the upper foam tray.



Removing Batter Conveyor from packaging



Heavy lifting may cause injury! Remove the breeder conveyors from the frame assembly before removing the frame assembly from the shipping container base.



Step 2: Release the locking latch and spacer lock.



Locking Latch



Spacer Lock

UNPACKING (CONTINUED)

Heavy lifting can cause injury. Use two-man lift.

Place frame assembly on a flat, level surface that can support 250+ pounds.

**Step 3: Remove discharge tray**

Discharge Tray

Step 4: Lift breader conveyor off of the bottom pan.

Bottom Pan

Breder Conveyor

UNPACKING (CONTINUED)

 **CAUTION**

Heavy lifting can cause injury. Use two-man lift.

Place frame assembly on a flat, level surface that can support 250+ pounds.



Step 5: Remove bottom pan off of the frame.



Bottom Pan

Step 6: Remove the frame assembly from the shipping container base and set it on a flat, level surface that can support 250+ pounds.



Shipping Container Base



INSTALLATION INSTRUCTIONS

Place frame assembly on a flat, level surface that can support 250+ pounds.

Step 1: Make sure that the locking latch is in the position shown.

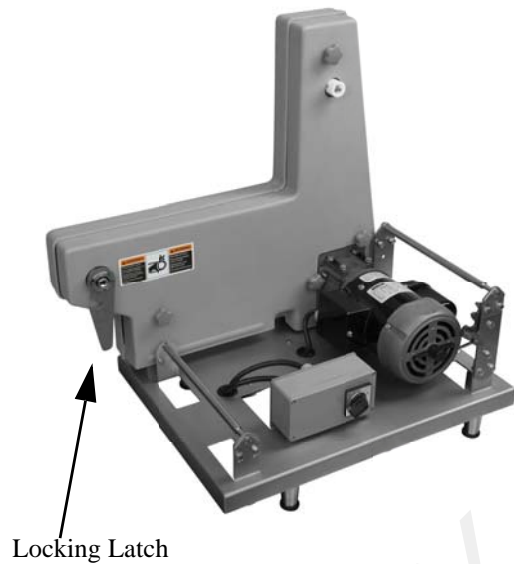

Locking Latch

Step 2: Set bottom pan onto frame with tab located as shown.



Bottom Pan

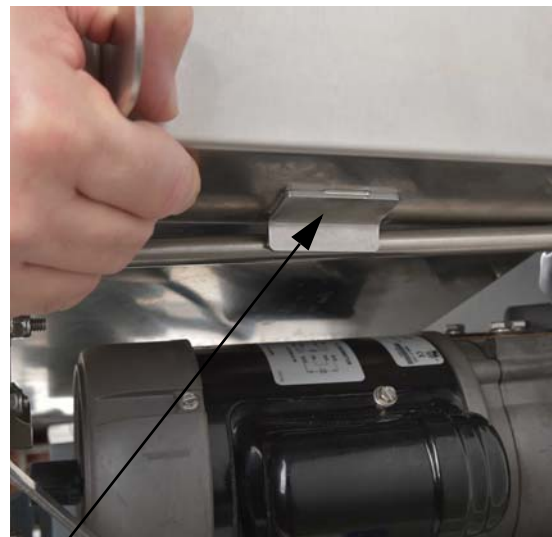

Tab



INSTALLATION INSTRUCTIONS (CONTINUED)

Step 3: Set the breeder conveyor onto the bottom pan.



Breeder Conveyor

Step 4: Position the front of the breeder conveyor to align with the drive shaft coupler.



Drive Shaft Coupler

INSTALLATION INSTRUCTIONS (CONTINUED)

Step 5: Rotate the breeder conveyor driven shaft square end so that it aligns with the square of the drive shaft coupler.

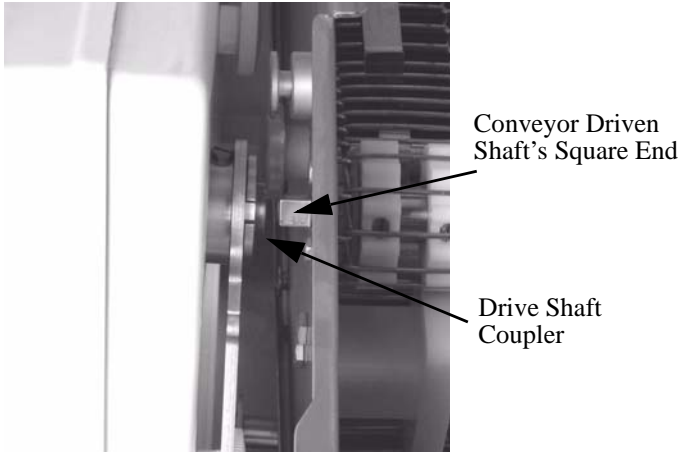

Step 6: Push the breeder conveyor's driven shaft into the drive shaft coupler until engaged.

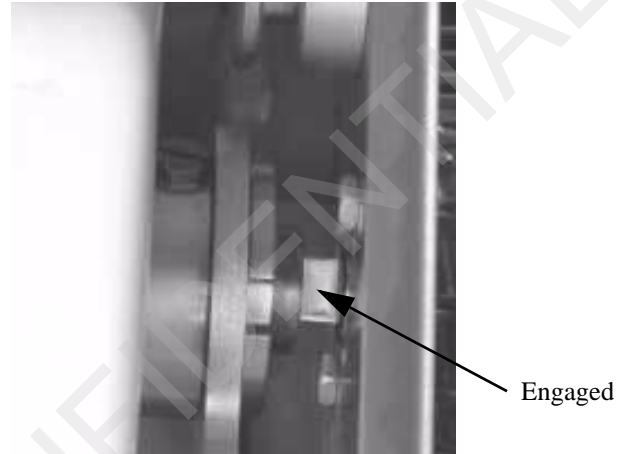

Step 7: Rotate latch into position.



Latch

Step 8: Rotate spacer lock into position.



Spacer Lock

INSTALLATION INSTRUCTIONS (CONTINUED)

Step 9: Assemble by installing:

Discharge Tray and Pan Bracket

- Place the slots of the pan bracket onto the flange of the breeder conveyor side rail.
- Position the bottom edge of discharge tray onto the bottom pan. Rotate discharge tray upward until it snaps into the breeder conveyor side rails.

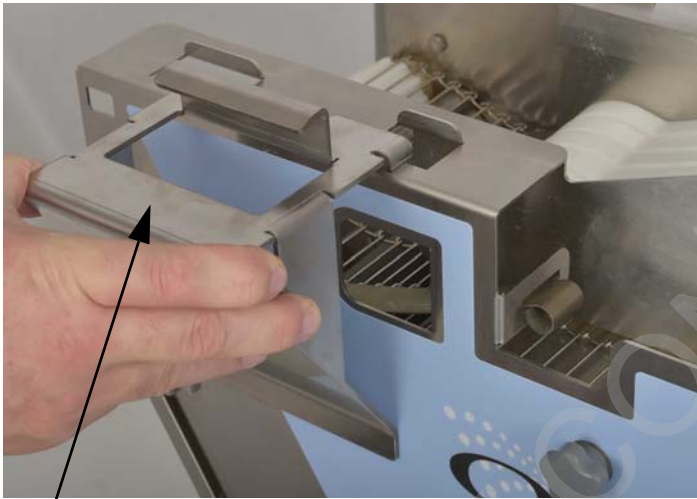

Pan Bracket

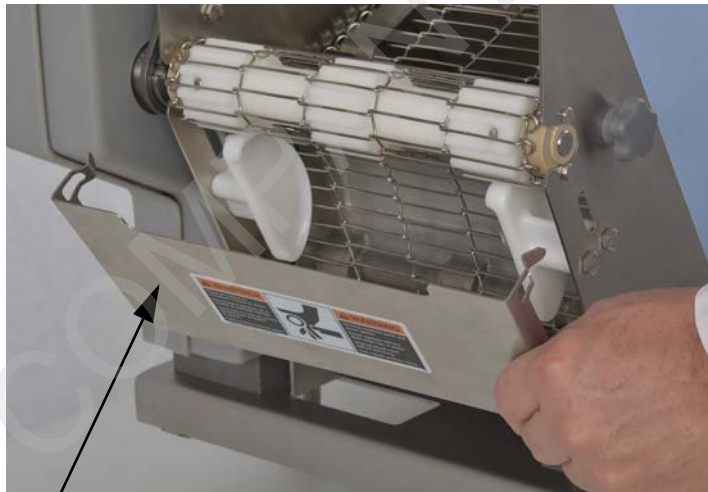

Discharge Tray

INSTALLATION INSTRUCTIONS (CONTINUED)

Step 10: Place the batter conveyor assembly into the batter tank.

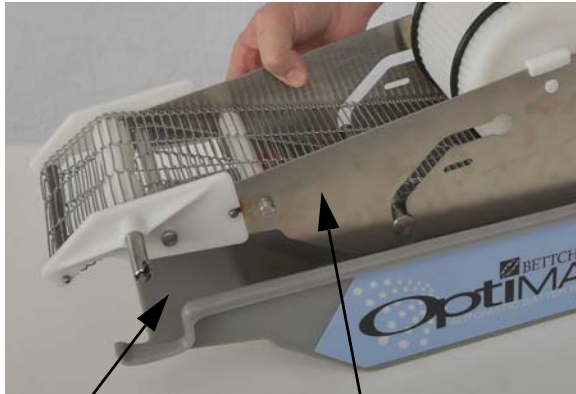

Batter Tank

Batter Conveyor Assembly

Step 11: Install the batter conveyor assembly and tank on the breader conveyor.



Step 12: Align the conveyor driven shaft with the bearing guide sleeve on the frame assembly.

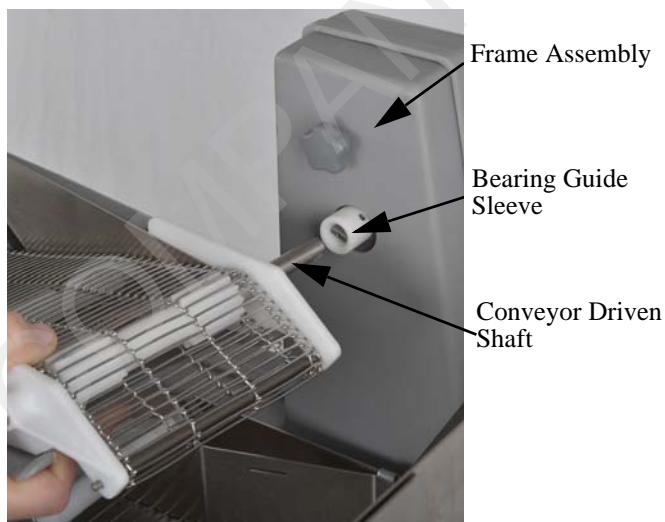

Frame Assembly

Bearing Guide Sleeve

Conveyor Driven Shaft

Step 13: Unit ready for pre-operational checkout.

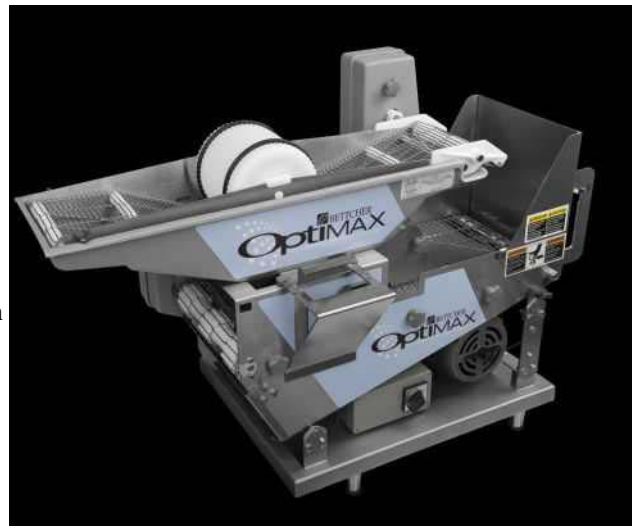

PRE-OPERATIONAL CHECKOUT

Step 1: Turn the power switch to **OFF**.

Step 2: Plug in the power cord.

Step 3: Turn the power switch to **ON**.

Step 4: Verify that the batter and breader conveyors are operating smoothly. The machine is now ready for adding the batter and breading as described in the operating instructions.





THIS PAGE INTENTIONALLY LEFT BLANK

COMPANY CONFIDENTIAL

Section 4

Instructions for Operation

CONTENTS OF THIS SECTION

Loading the Breader Tank	4-2
Loading the Batter Tank	4-3
Product Coating Operation.....	4-4



To avoid personal injury, guards must be in place while operating the machine.



Never operate without guards in place.

Moving machine parts and pinch points.
Never operate without discharge tray in place.

Sprocket and Chain

To avoid personal injury, guards must be in place while operating the machine.



LOADING THE BREADING

Step 1: Turn the machine **ON**.

Step 2: Scoop the breading into the breader conveyor assembly.

Step 3: Continue to fill the breader conveyor assembly, with the conveyor running, until the breading depth is even with fill slot.



Fill Slot

LOADING THE BATTER

Step 1: Turn the machine **OFF**.

Step 2: Fill the batter conveyor assembly with batter.

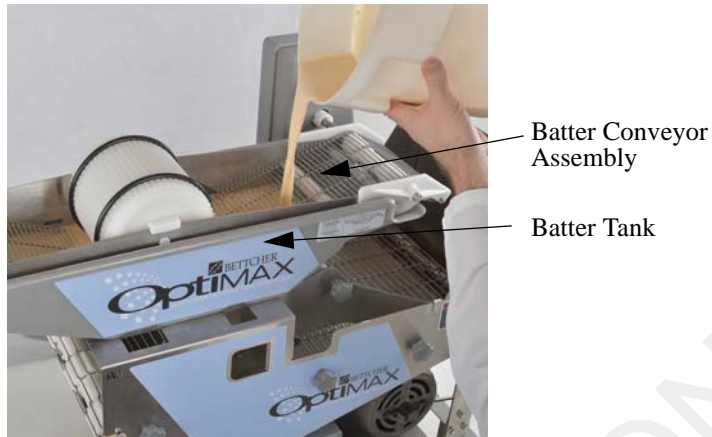

Step 3: Stop filling when the batter reaches the top of the slots in both side plates of the batter conveyor assembly.

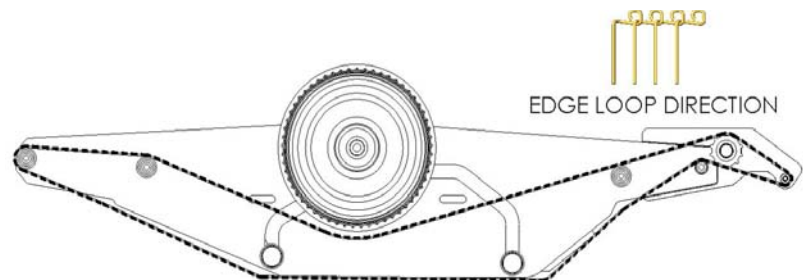
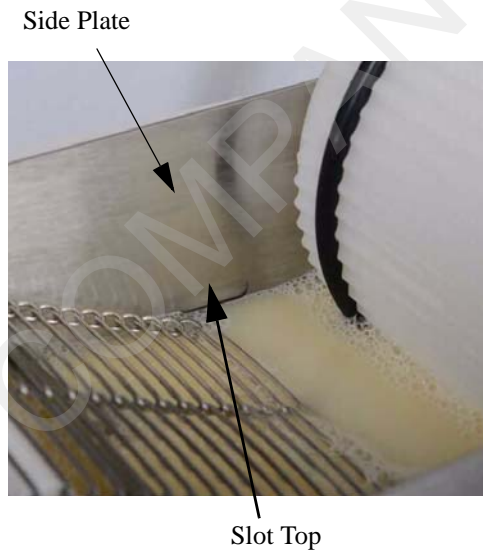

PRODUCT COATING OPERATION

Step 1: Turn the machine **ON**.

NOTE

Always place the product in the center of the conveyor. For best results, leave some space between each piece of product.

Step 2: Place the product on the center of the batter conveyor assembly. The product is coated with batter as it passes under the wheel.



Step 3: The product will be coated with breading as it goes through the throat guides and under the paddle assembly. The product will exit at the front end of the breader.

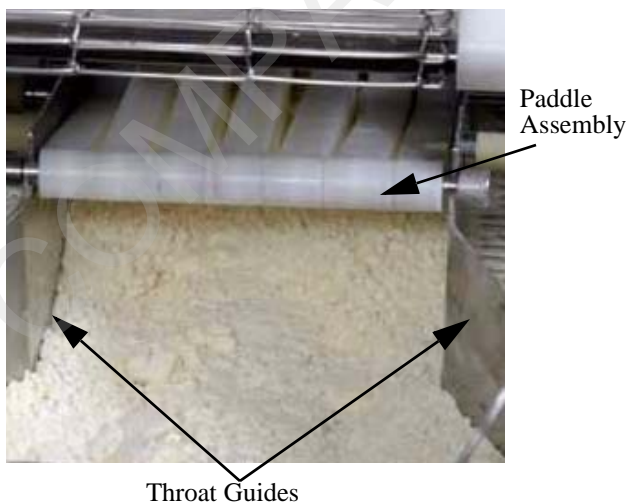

Table of Contents

Section 5 Maintenance

Section 5A	Batter Conveyor Assembly
Section 5B	Breder Conveyor Assembly
Section 5C	Frame Assembly
Section 5D	Preventive
Section 5E	Trouble Shooting

Optimax[®]



Section 5A

Maintenance Batter Conveyor Assembly

CONTENTS OF THIS SECTION

Batter Conveyor Arm Replacement	5A-2
Batter Conveyor Wirebelt Replacement	5A-3
Batter Conveyor Driven Shaft Replacement	5A-8
Batter Tank Alignment	5A-14

 **WARNING**



All maintenance procedures should be performed by qualified personnel.

The information provided in these operating instructions is important to your health, comfort and safety. For safe and proper operation, read this entire manual before using this equipment.

Please read and save these instructions. Read carefully before attempting to assemble, install, operate or maintain this product. Protect yourself, others and equipment by observing all safety information. Failure to comply with instructions could result in personal injury and/or damage to the equipment. Any use in applications other than those for which the equipment was designed and built may result in equipment damage and/or serious injuries.

Retain this manual for future reference. Be thoroughly familiar with the controls and proper use of this equipment.

The manufacturer assumes no liability for any unauthorized changes in operating procedures or for unauthorized changes or modifications made to the design of the machine or any factory-installed safety equipment, whether these changes are made by the owner of this equipment, by his employees, or by service providers not previously approved by Bettcher Industries, Inc.

Use only replacement parts manufactured by Bettcher Industries, Inc. Use of substitute parts will void the warranty and may cause injury to operators and damage the equipment.

 **WARNING**

Never attempt to repair a wirebelt that has been previously repaired or has damage in more than one place. A belt with these properties could have small pieces break off into the product long before the next failure is noticed.



BATTER CONVEYOR ARM REPLACEMENT

Step 1: Remove the retaining thumbscrew from one side of the batter conveyor arm and lift it off of the driven shaft.

Step 2: Install the new conveyor arm and tighten the retaining thumbscrews. Replace the conveyor arm on the opposite side, using the same procedure. **See the belt path label to ensure proper tracking.*

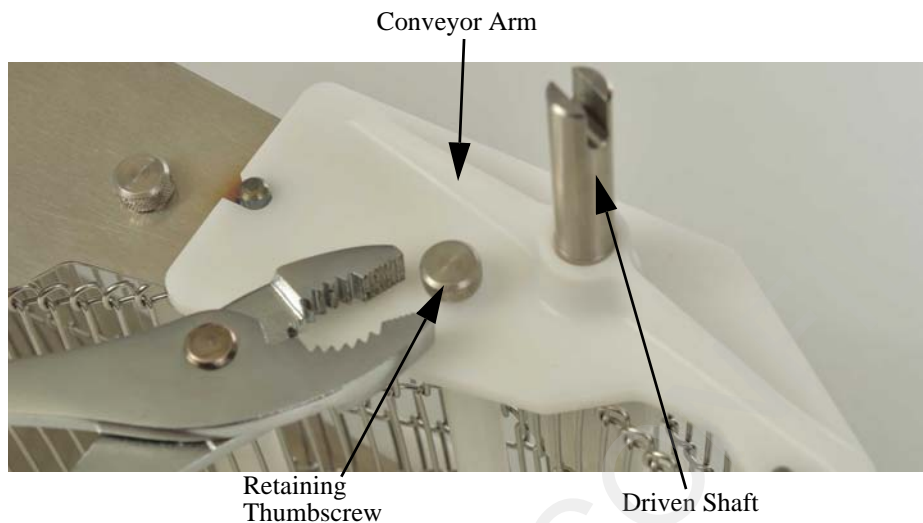

NOTICE

If the wirebelt is installed improperly, damage to the wirebelt may result. Refer to the wirebelt replacement instructions in this section of the manual.

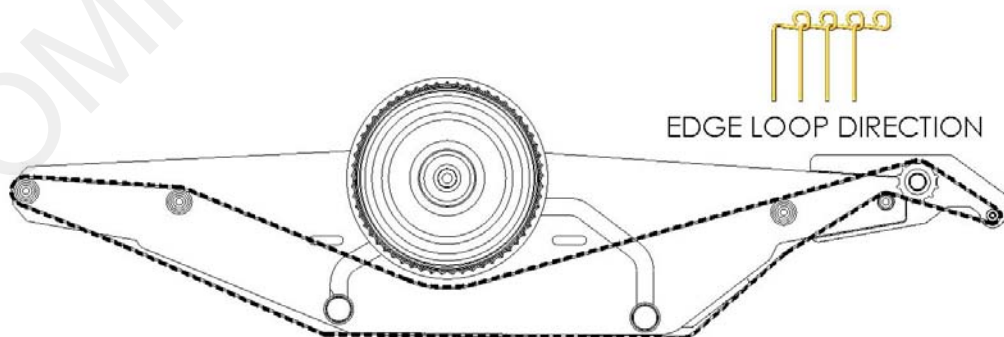

BATTER CONVEYOR WIREBELT REPLACEMENT

Step 1: Remove the batter wheel by slightly spreading the conveyor side rails open and slipping the wheel from its mounts.

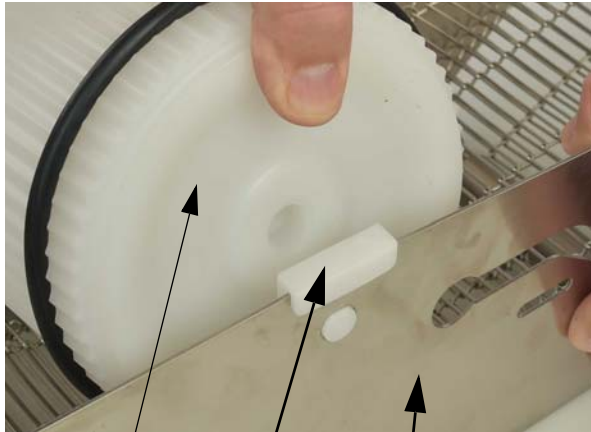

Batter Wheel Mount Side Rail

Step 2: Place the batter conveyor assembly on its side. Remove the retaining thumbscrews from one side of the conveyor then slide the conveyor arm off the driven shaft.

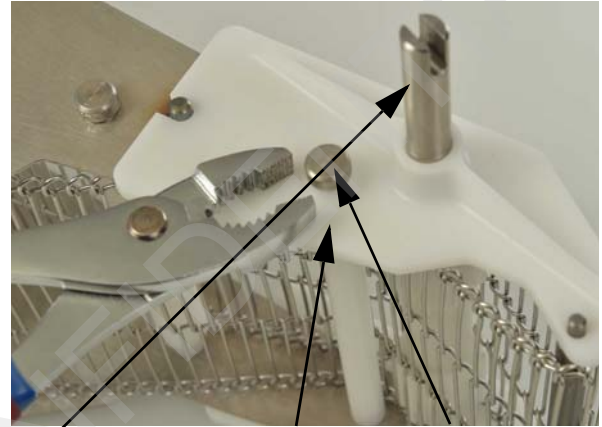

Driven Shaft Conveyor Arm Retaining Thumbscrew

Step 3: Remove the conveyor side rail and slide the wirebelt from the assembly.



Wirebelt



BATTER CONVEYOR WIREBELT REPLACEMENT (CONTINUED)

NOTICE

If the wirebelt is installed improperly, damage to the wirebelt may result.

Step 4: Place the new wirebelt between the side rails. Make certain the edge loops are facing the direction of travel. **See the belt path view.*

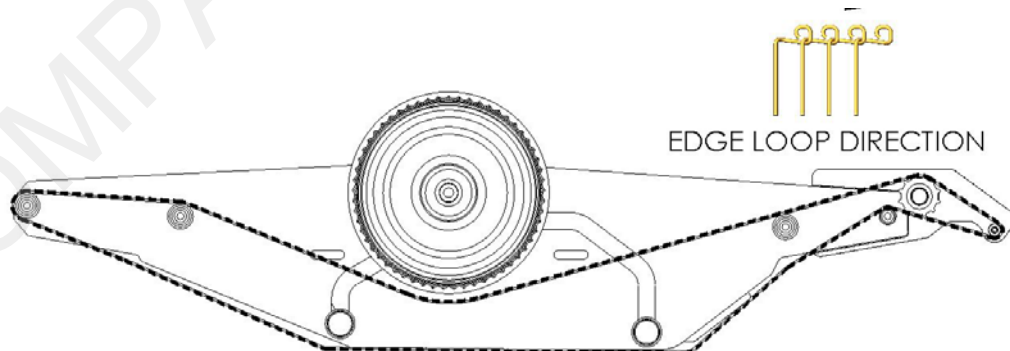
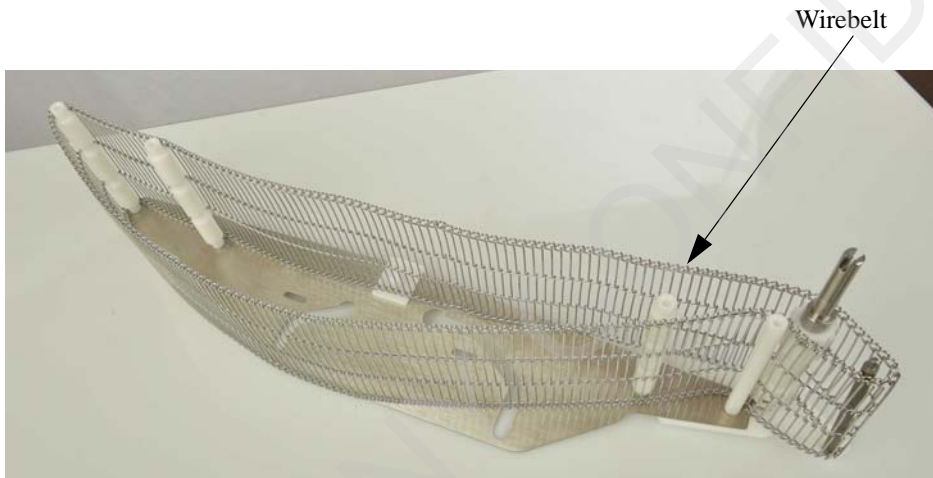

BATTER CONVEYOR WIREBELT REPLACEMENT (CONTINUED)

Step 5: Reinstall the side rail, conveyor arm, and thumbscrews.

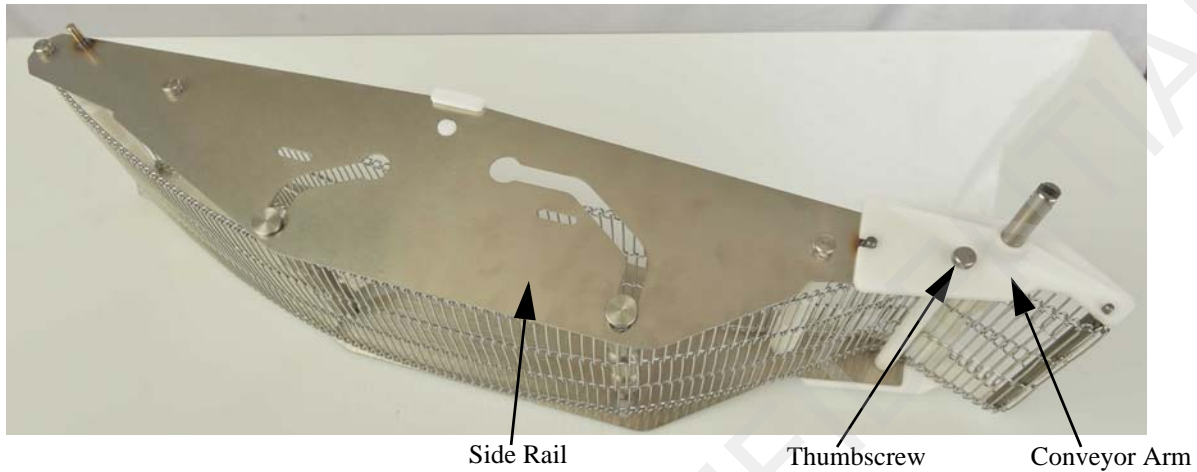

Step 6: Tighten thumbscrews.

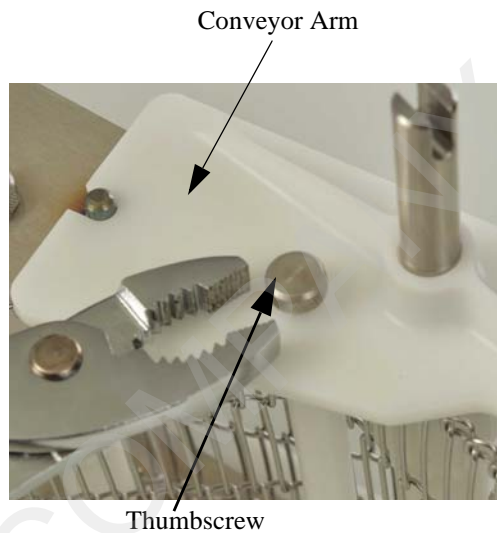



BATTER CONVEYOR WIREBELT REPLACEMENT (CONTINUED)

Step 7: Insert the batter wheel assembly into the batter conveyor by slightly spreading the side rails. Make certain that the wirebelt edge loop flats are in the directions shown.

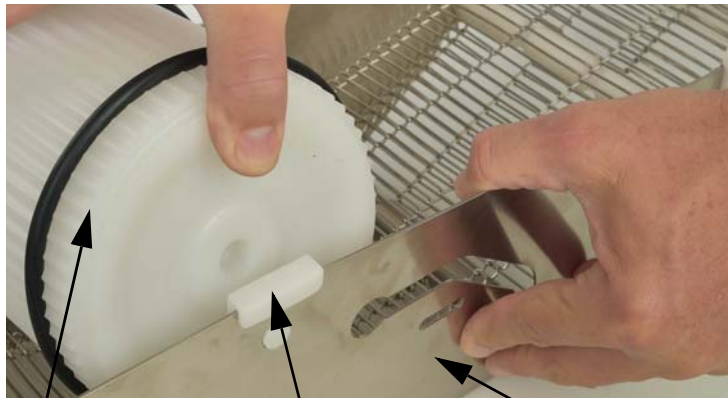

Batter Wheel Assembly

Mount

Side Rail

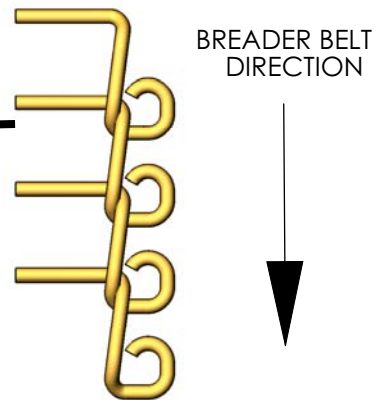
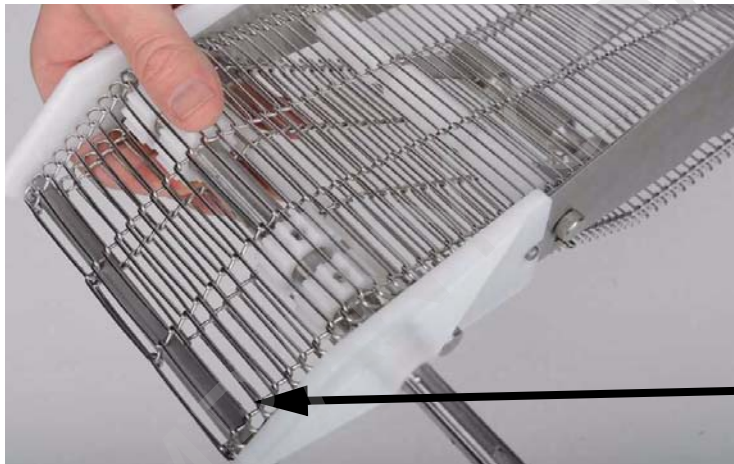

NOTICE

If wirebelt is installed improperly, damage to the wirebelt may result.

BATTER CONVEYOR WIREBELT REPLACEMENT (CONTINUED)

Step 8: Install the batter conveyor assembly into the batter tank.



COMPANY CONFIDENTIAL



BATTER CONVEYOR DRIVEN SHAFT REPLACEMENT

Step 1: Remove the batter conveyor assembly from the batter tank and clean it, before attempting to remove the batter conveyor driven shaft components from the conveyor. *See cleaning instructions, Section 6.

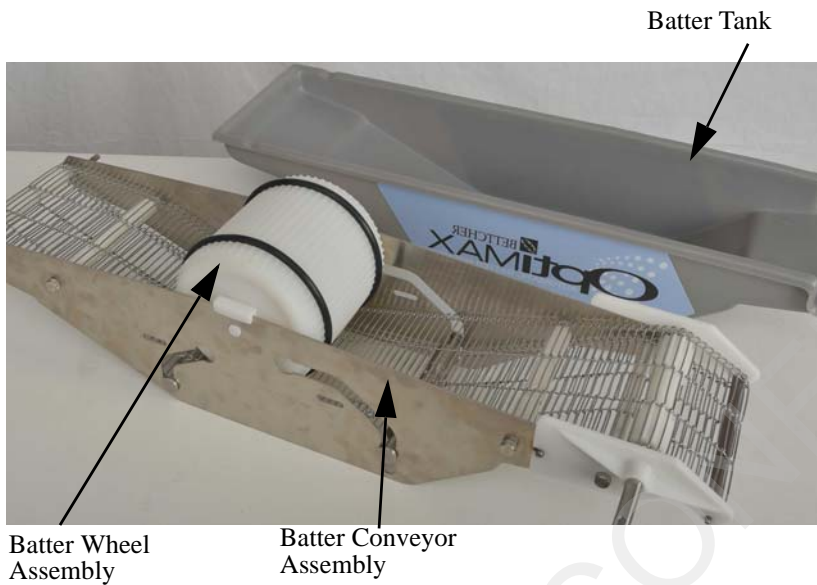

Step 2: Remove the batter wheel assembly by slightly spreading the conveyor side rails open and slipping the wheel from its mounts.

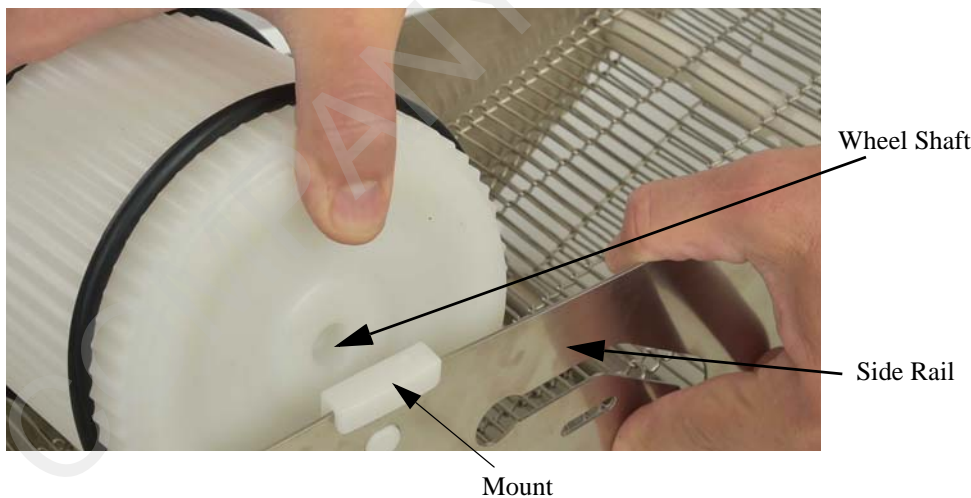

BATTER CONVEYOR DRIVEN SHAFT REPLACEMENT (CONTINUED)

Step 3: Place the batter conveyor assembly on its side. Remove the retaining thumbscrew from one side of the conveyor and slide the batter conveyor arm off of the shaft.

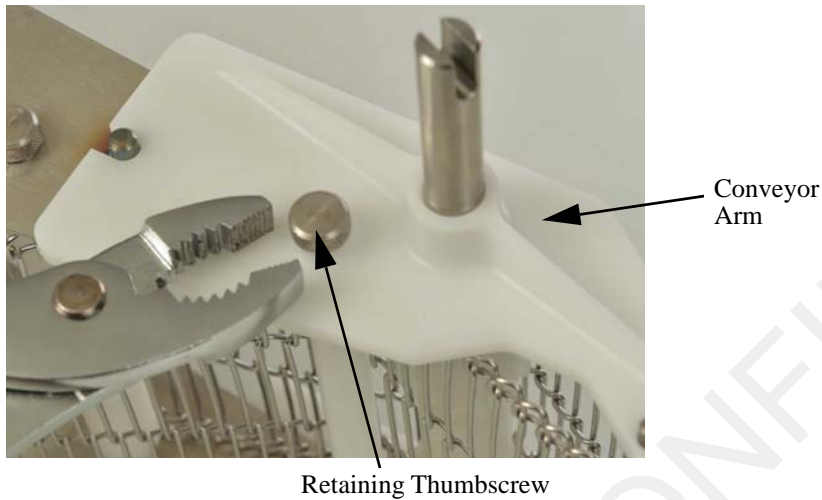

Step 4: Slide the driven shaft with sprockets out from the wirebelting.

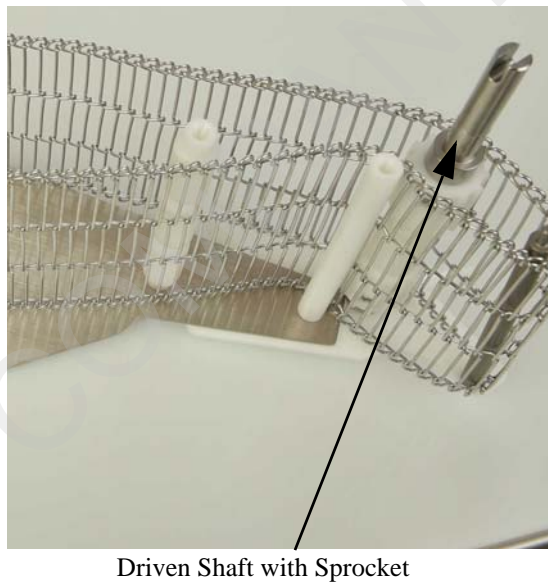



BATTER CONVEYOR DRIVEN SHAFT REPLACEMENT (CONTINUED)

Step 5: Loosen the set screws on the sprocket end and remove the driven shaft.

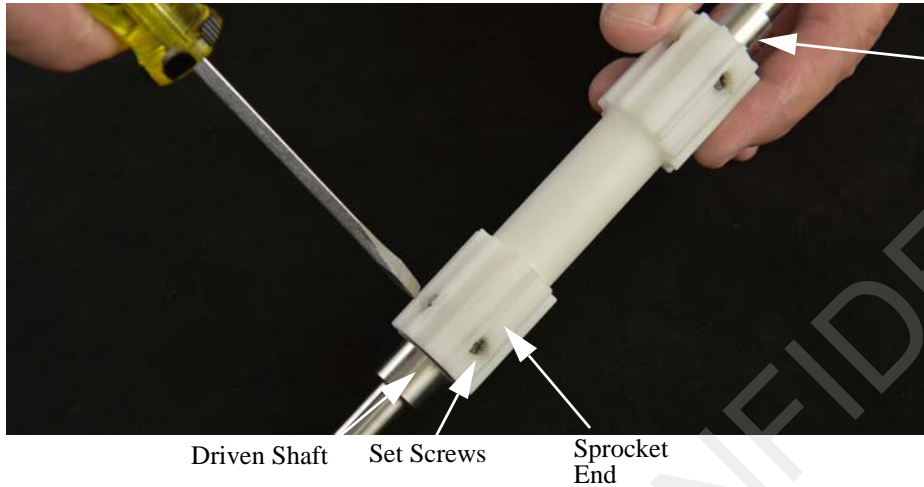

Step 6: Insert the new driven shaft into the sprocket end, aligning the sprocket hole with the orientation dimple on the driven shaft. Tighten set screws.

Orientation Dimple



BATTER CONVEYOR DRIVEN SHAFT REPLACEMENT (CONTINUED)

Step 7: Install the completed driven shaft assembly into the conveyor assembly. Make sure the driven shaft assembly is installed facing the proper direction. Confirm the driven shaft assembly is inside of the wirebelt.

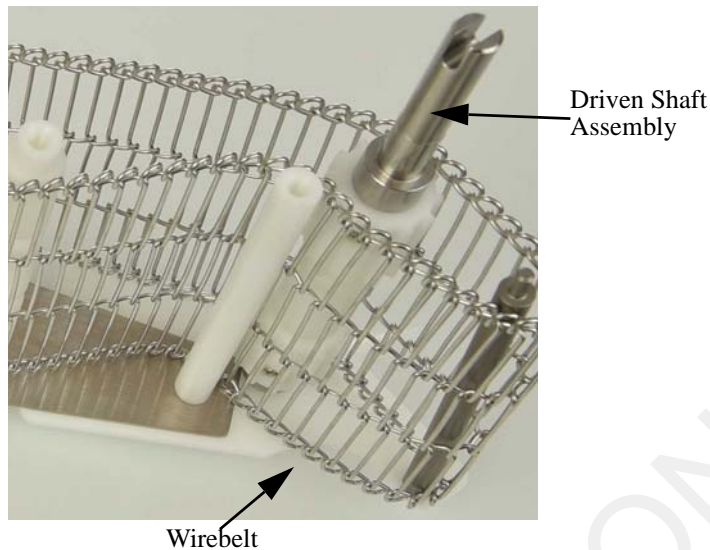

NOTICE

If wirebelt is installed improperly, damage to the wirebelt may result.

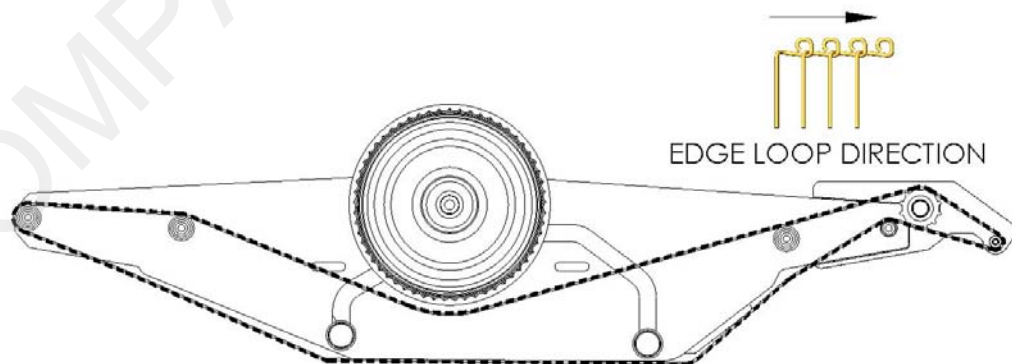



BATTER CONVEYOR DRIVEN SHAFT REPLACEMENT (CONTINUED)

Step 8: Align and reinstall conveyor arm and thumbscrew. Tighten thumbscrew.

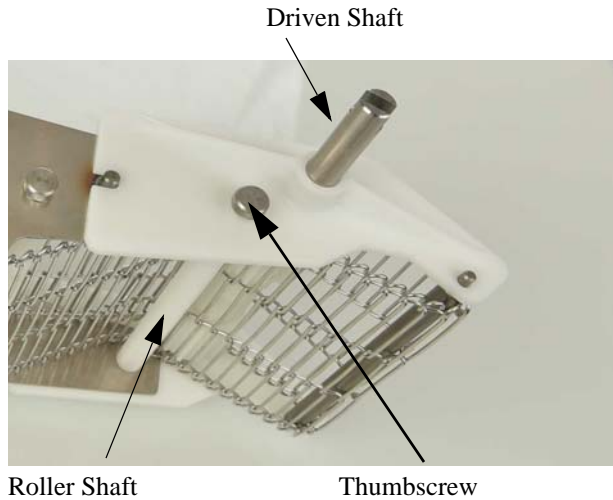

Step 9: Rotate the driven shaft by hand to ensure that it turns freely.

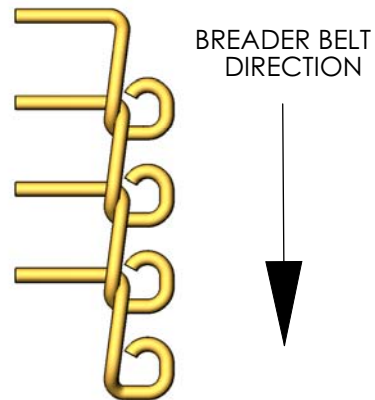
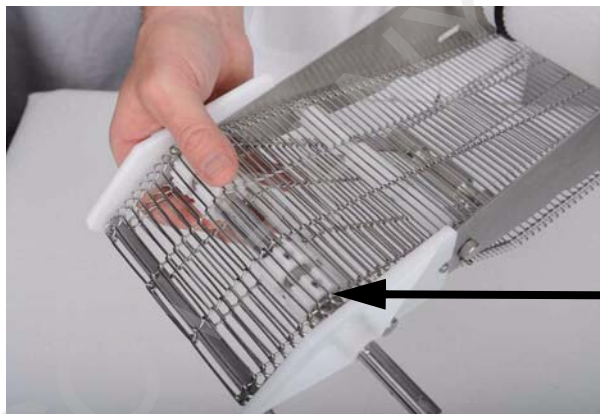

NOTICE

If wirebelt is installed improperly, damage to the wirebelt may result.

BATTER CONVEYOR DRIVEN SHAFT REPLACEMENT (CONTINUED)

Step 10: Install the batter conveyor assembly into the batter tank.



COMPANY CONFIDENTIAL



BATTER TANK ALIGNMENT

Step 1: If the batter tank driven shaft doesn't seem to engage the drive shaft properly, simply try sliding the batter tank either forward or backwards until the alignment improves.



← Batter Tank

← Batter Tank Mount

NOTICE

If further adjustment is required, please contact Bettcher Industries at 1 800 321-8763.

Section 5B

Maintenance Breader Conveyor Assembly

CONTENTS OF THIS SECTION

Breader Conveyor Bearings and Driven Shaft	5B-2
Wirebelt Replacement	5B-13

 **WARNING**



All maintenance procedures should be performed by qualified personnel.

The information provided in these operating instructions is important to your health, comfort and safety. For safe and proper operation, read this entire manual before using this equipment.

Please read and save these instructions. Read carefully before attempting to assemble, install, operate or maintain this product. Protect yourself, others and equipment by observing all safety information. Failure to comply with instructions could result in personal injury and/or damage to the equipment. Any use in applications other than those for which the equipment was designed and built may result in equipment damage and/or serious injuries.

Retain this manual for future reference. Be thoroughly familiar with the controls and proper use of this equipment.

The manufacturer assumes no liability for any unauthorized changes in operating procedures or for unauthorized changes or modifications made to the design of the machine or any factory-installed safety equipment, whether these changes are made by the owner of this equipment, by his employees, or by service providers not previously approved by Bettcher Industries, Inc.

Use only replacement parts manufactured by Bettcher Industries, Inc. Use of substitute parts will void the warranty and may cause injury to operators and damage the equipment.

 **WARNING**

Never attempt to repair a wirebelt that has been previously repaired or has damage in more than one place. A belt with these properties could have small pieces break off into the product long before the next failure is noticed.

BREADER CONVEYOR BEARINGS AND DRIVEN SHAFT

Step 1: Disassemble breader conveyor by removing:

Discharge Tray

- Pull the top of the discharge tray away from the breader assembly releasing the tray from the breader holes.

Discharge Tray

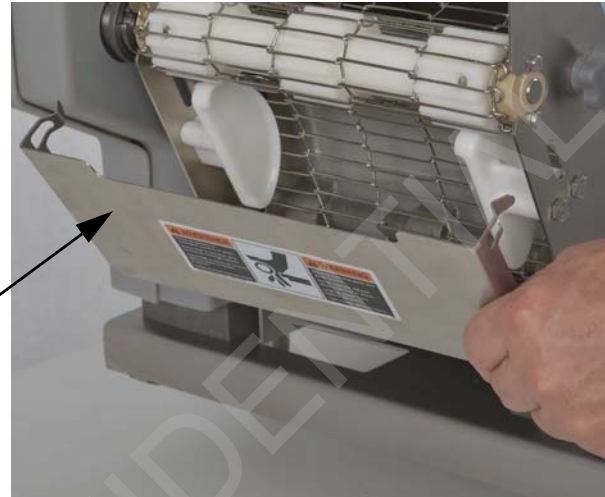
**Pan Bracket**

- Remove the pan bracket from the breader conveyor side rail.

Pan Bracket

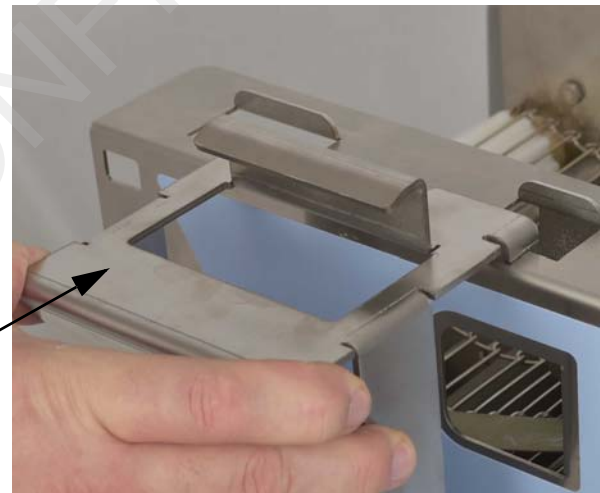
**Breader Conveyor Assembly**

- Remove breader conveyor assembly off of bottom pan.

Bottom Pan

Breader Conveyor Assembly



BREADER CONVEYOR BEARINGS AND DRIVEN SHAFT (CONTINUED)

Paddle Assembly

- Remove knob, shaft and paddles.

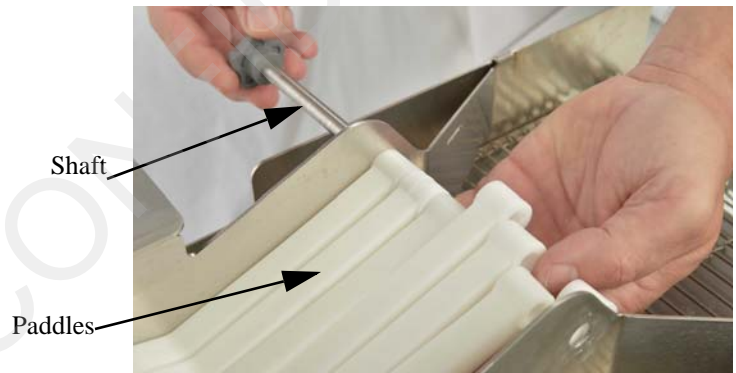



BREADER CONVEYOR BEARINGS AND DRIVEN SHAFT (CONTINUED)

Vibrator Springs

- Remove vibrator springs from slots.

Vibrator Spring

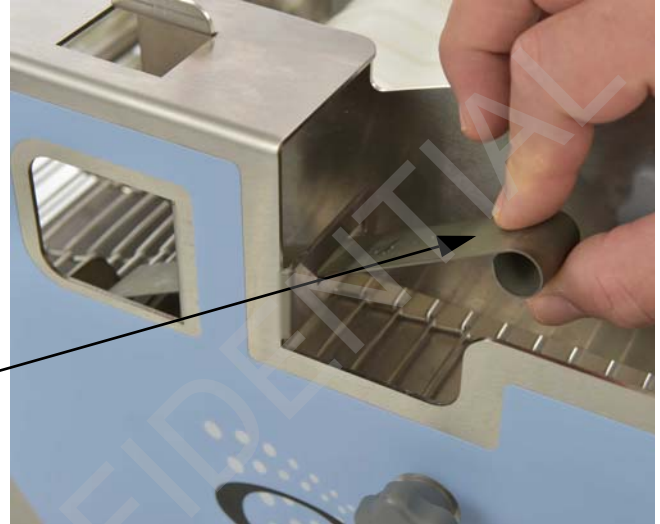

Slot

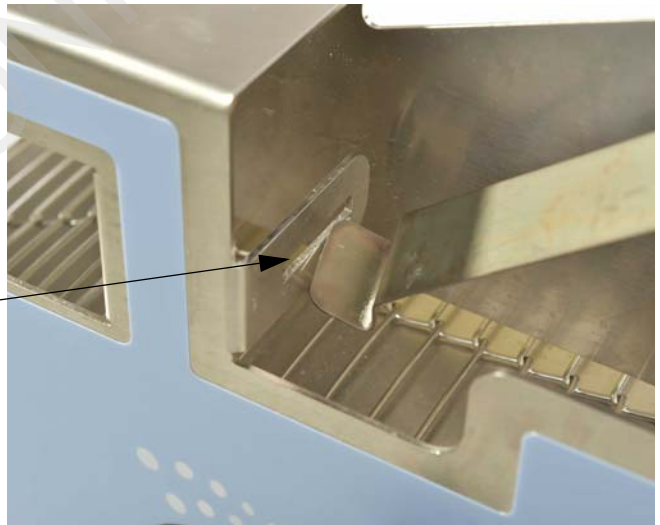

BREADER CONVEYOR BEARINGS AND DRIVEN SHAFT (CONTINUED)

NOTE

When removing the side rail, lift from the front of the side rail and work your way to the rear.

NOTE

Make sure that the bearing assemblies remain on the support shaft.

Step 2: Remove the knobs from one side of the breader conveyor. Lift the side rail off of the breader conveyor. **Make sure that the bearing assemblies remain on the support shaft.*

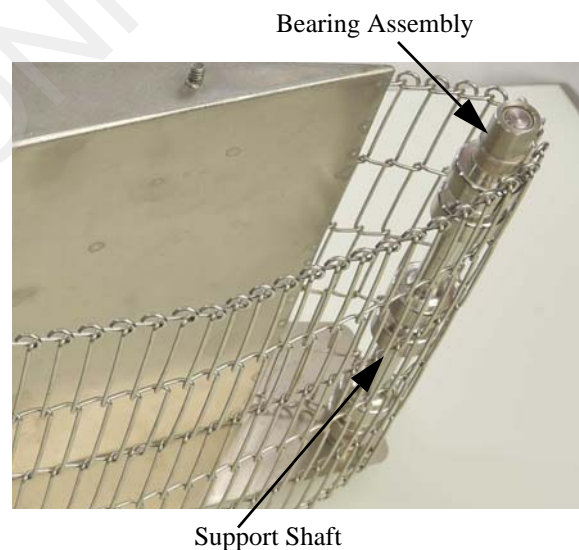
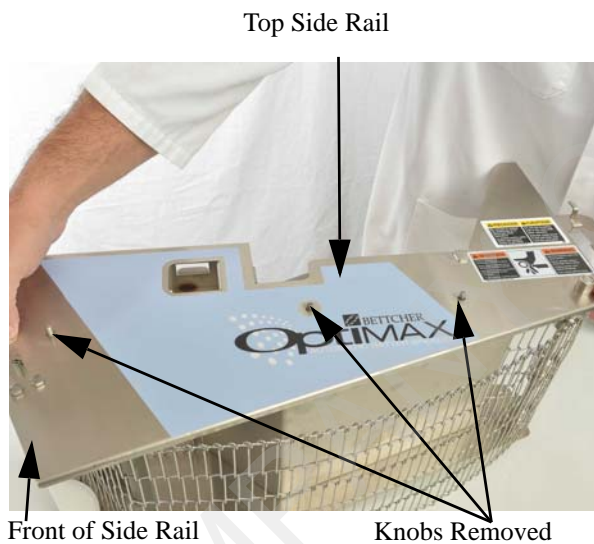

**BREADER CONVEYOR BEARINGS AND DRIVEN SHAFT
(CONTINUED)**

Step 3: Remove the sprocket assembly from the breder conveyor assembly.

Sprocket Assembly

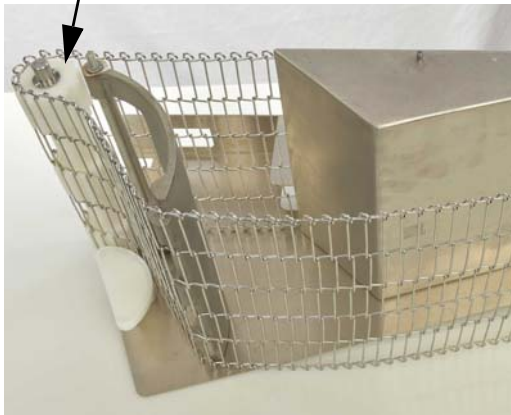

Step 4: Remove the bearings from the side rails by removing the retaining screws, using a 5/16" wrench or nut driver. Install the new bearings, using the same retaining screws. **Do not overtighten.*

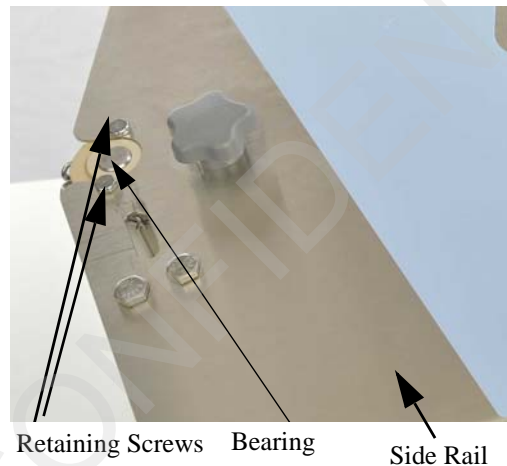

Step 5: Using a flat blade screw driver, loosen the sprocket set screws and remove the driven shaft from the sprocket assembly end.

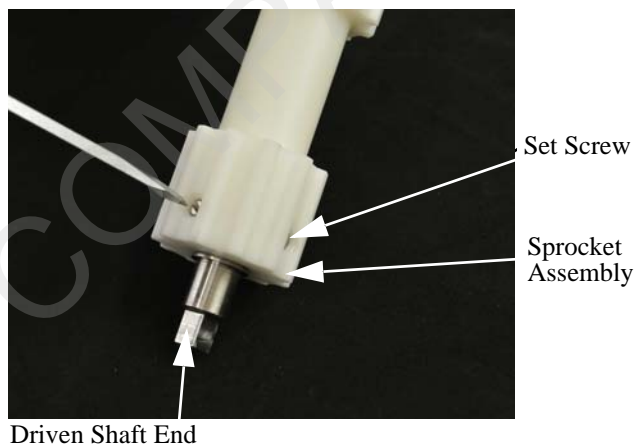

BREADER CONVEYOR BEARINGS AND DRIVEN SHAFT (CONTINUED)



Do not over tighten screws in plastic components. Damage may occur.

Step 6: Slide the new driven shaft end into the sprocket assembly, positioning the sprocket hole over the orientation dimple. Install the set screws into the sprocket assembly and tighten.

Orientation Dimple

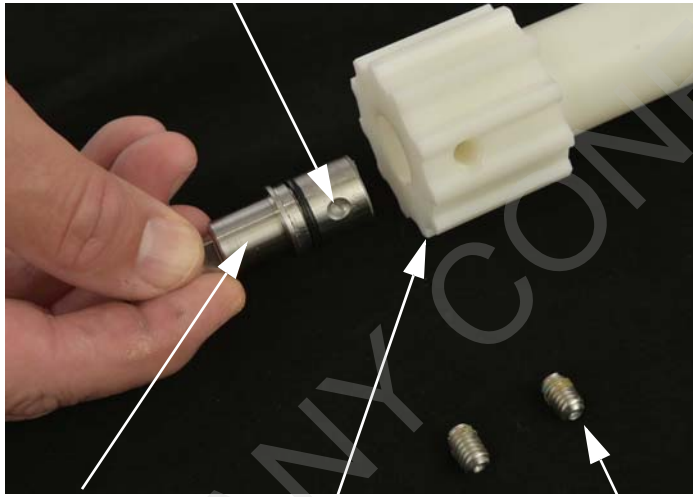

Driven Shaft
End

Sprocket Assembly

Set Screw



BREADER CONVEYOR BEARINGS AND DRIVEN SHAFT (CONTINUED)

NOTE

The driven shaft will only fit properly one way. If it doesn't install properly, turn it over and try again.



All sprockets must be in alignment with the wirebelting.

Step 7: Reinstall the driven shaft. Align the sprockets with the wirebelting.

Driven Shaft



BREADER CONVEYOR BEARINGS AND DRIVEN SHAFT (CONTINUED)

Step 8: Reinstall the breader side rail and (3) knobs, installing from the front end of the side rail and working your way towards the rear. **Make sure all components are located and aligned prior to tightening the knobs.*

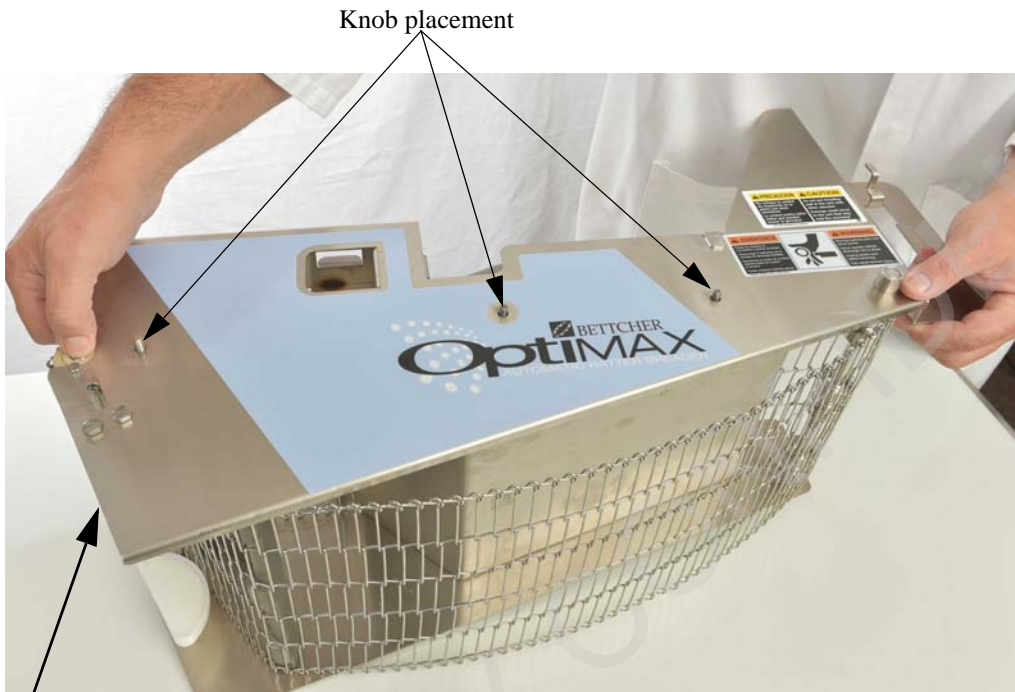

Front of Side Rail



BREADER CONVEYOR BEARINGS AND DRIVEN SHAFT (CONTINUED)

Step 9: Reassemble by installing:

Vibrator Springs

- Install vibrator springs into slots.

Slot

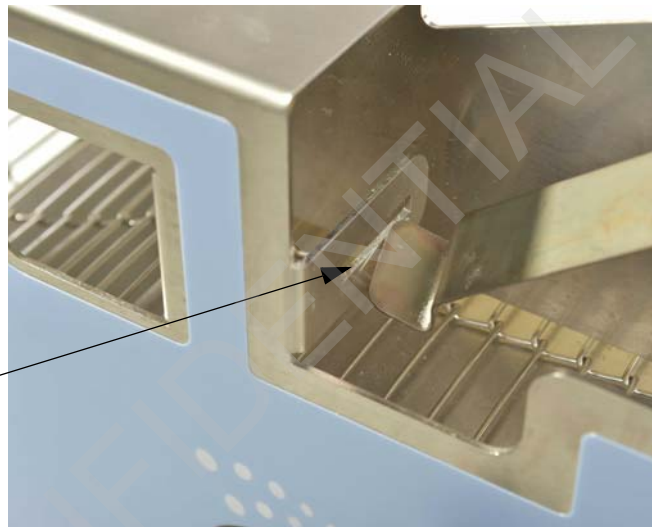

Vibrator Spring

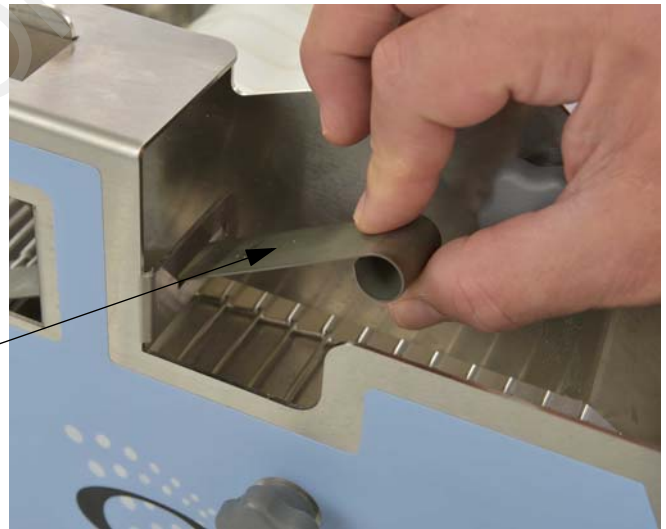



BREADER CONVEYOR BEARINGS AND DRIVEN SHAFT (CONTINUED)

Paddle Assembly

- Install knob, shaft and paddles.

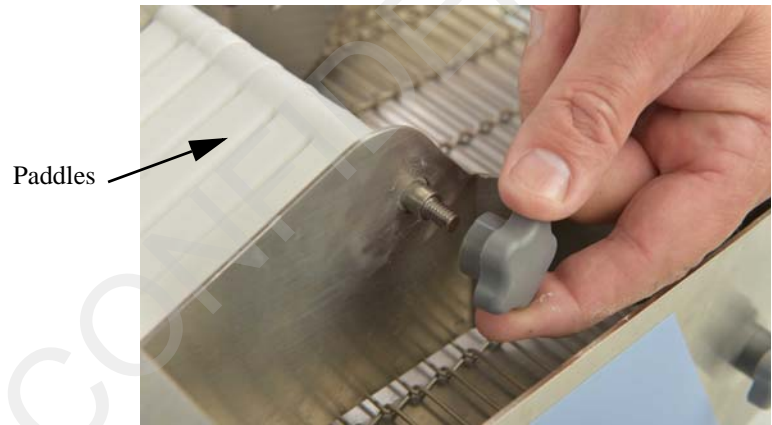

Breader Conveyor

- Install breader conveyor assembly onto bottom pan.

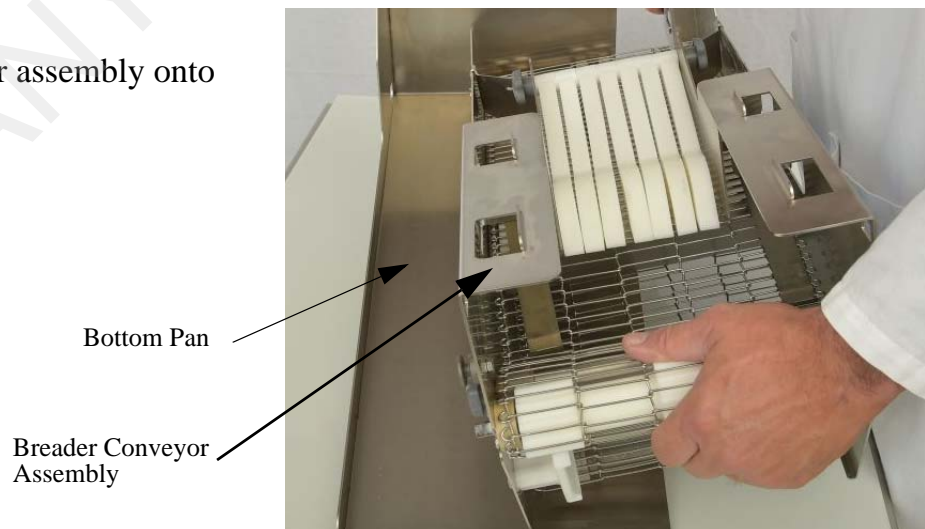

**BREADER CONVEYOR BEARINGS AND DRIVEN SHAFT
(CONTINUED)****Discharge Tray**

- Position the bottom edge of discharge tray onto the bottom pan. Rotate discharge tray upward until it snaps into the breader conveyor side rails.

Discharge Tray

**Pan Bracket**

- Install the pan bracket onto the breader conveyor side rail.

Pan Bracket

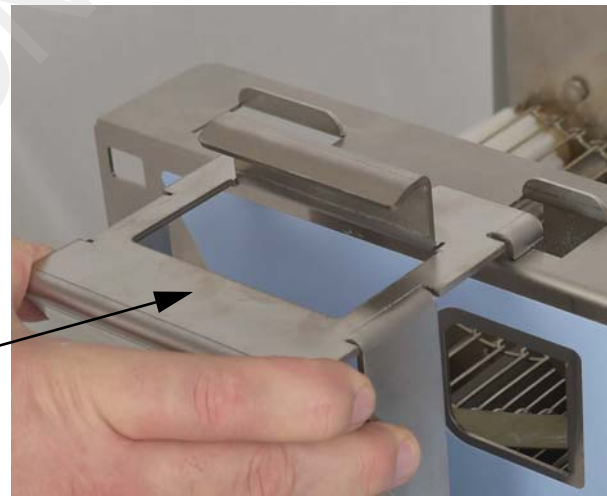

WIREBELT REPLACEMENT

Step 1: Disassemble breader conveyor by removing:

Discharge Tray

- Pull the top of the discharge tray away from the breader assembly releasing the tray from the breader holes.

Discharge Tray



Pan Bracket

- Remove the pan bracket from the breader conveyor side rail.

Pan Bracket

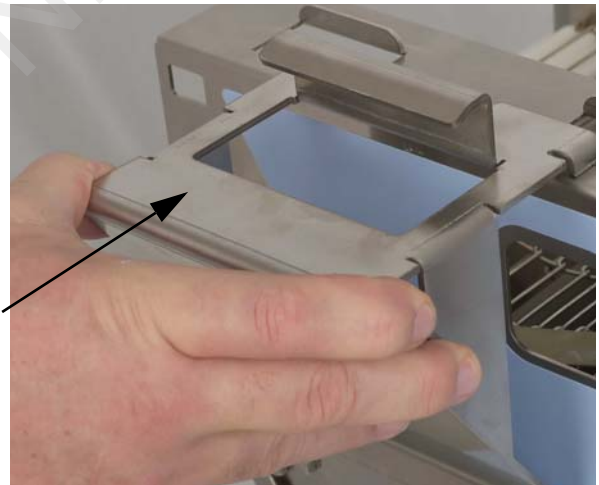

WIREBELT REPLACEMENT (CONTINUED)**Paddle Assembly**

- Remove knob, shaft and paddles.

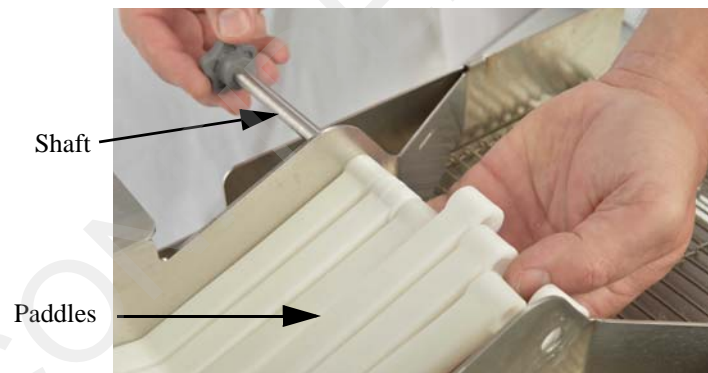
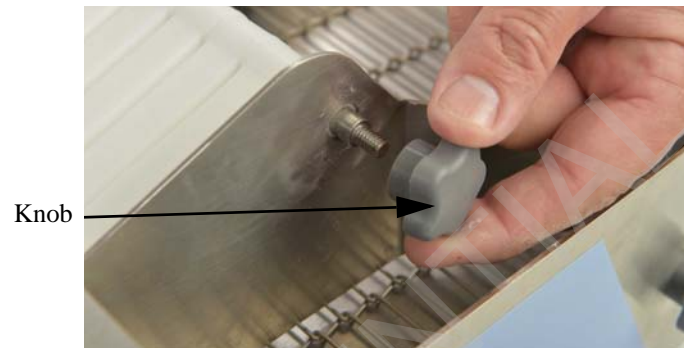

WIREBELT REPLACEMENT (CONTINUED)

Vibrator Springs

- Remove vibrator springs from slots.

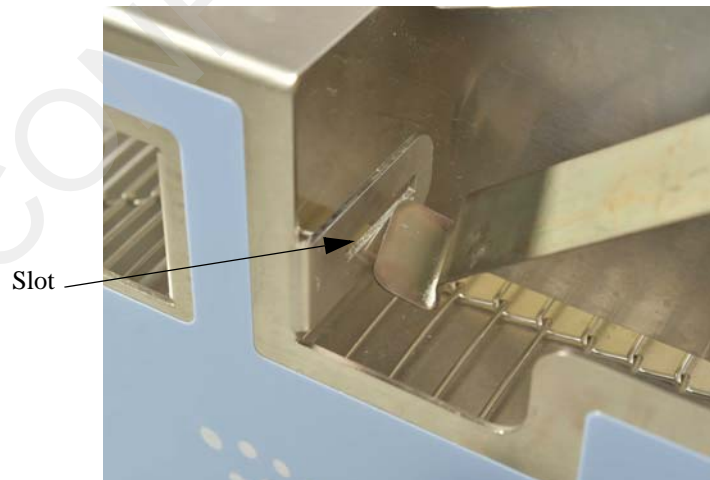
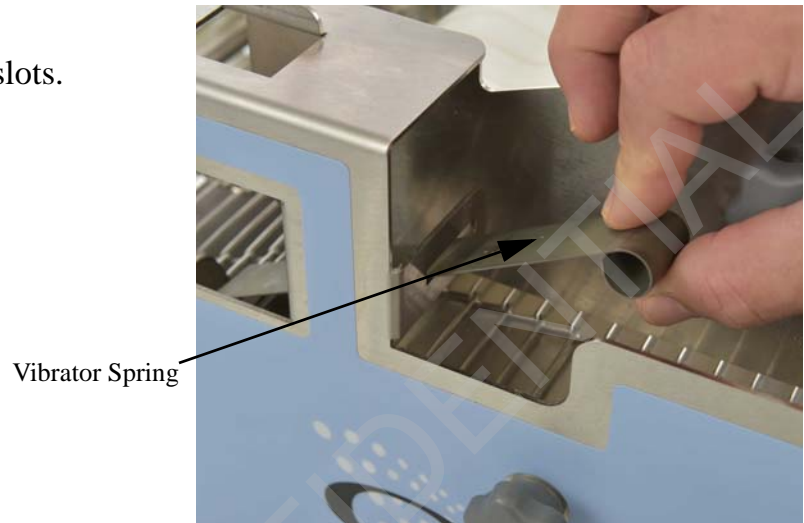

WIREBELT REPLACEMENT (CONTINUED)**NOTE**

When removing the side rail, lift from the front of the side rail and work your way to the rear.

NOTE

Make sure that the bearing assemblies remain on the support shaft.

Step 2: Remove the knobs from one side of the breder conveyor. Lift the side rail off of the breder conveyor. **Make sure that the bearing on the support shaft assembly remains intact.*

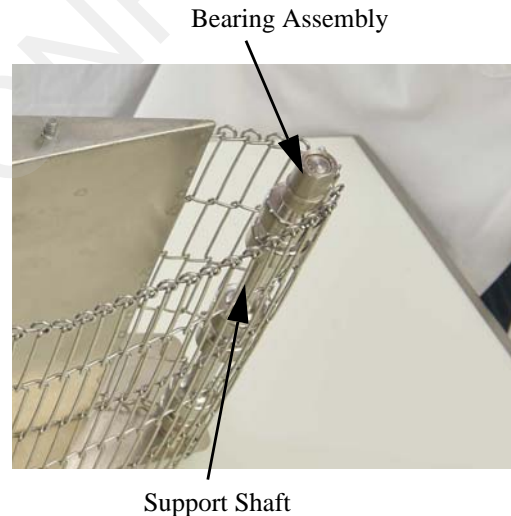
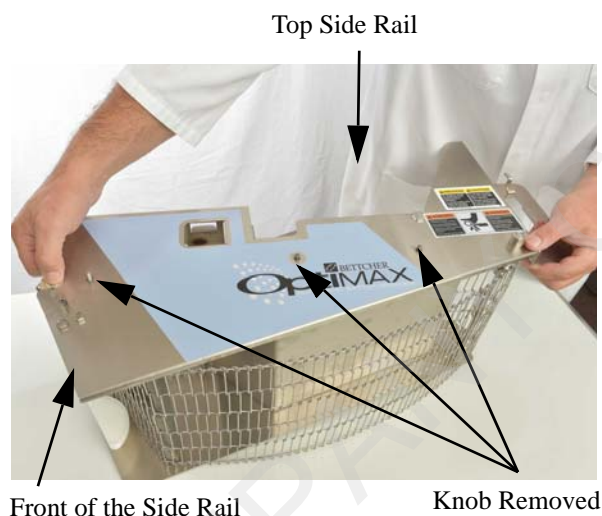

WIREBELT REPLACEMENT (CONTINUED)

Step 3: Remove the sprocket assembly and wirebelt from the breader conveyor assembly.

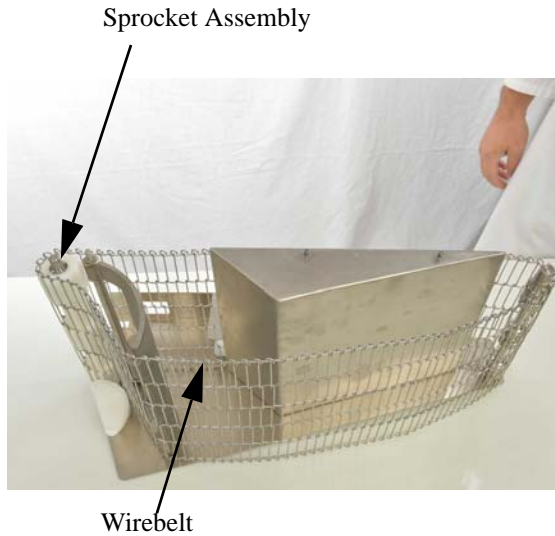

Make sure wirebelt is installed in the proper direction.

Sprocket Assembly will only fit properly one way. If it doesn't install properly, turn it over and try again.

All sprockets must be in alignment with the wirebelting.

Step 4: Install the new wirebelt and sprocket assembly, making sure the wirebelt is installed behind the idler block. **See the belt path label to ensure proper tracking.*



Idler Block

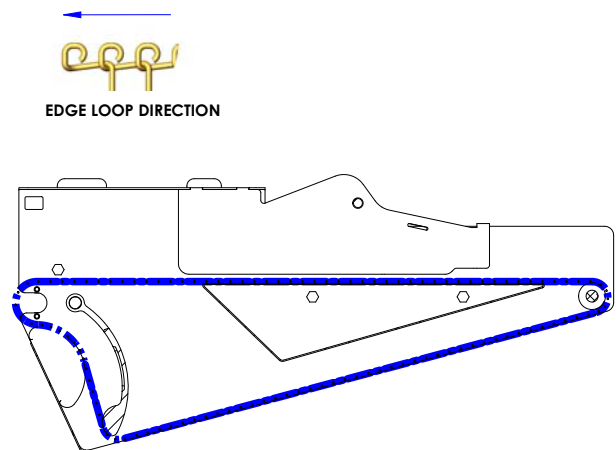



WIREBELT REPLACEMENT (CONTINUED)

Step 5: Reinstall the breder side rail and knobs, installing from the front end of the side rail and working your way towards the rear. **Make sure all components are located and aligned prior to tightening the knobs.*



WIREBELT REPLACEMENT (CONTINUED)

Step 6: Reassemble by installing:

Vibrator Springs (3)

- Install vibrator springs into slots.

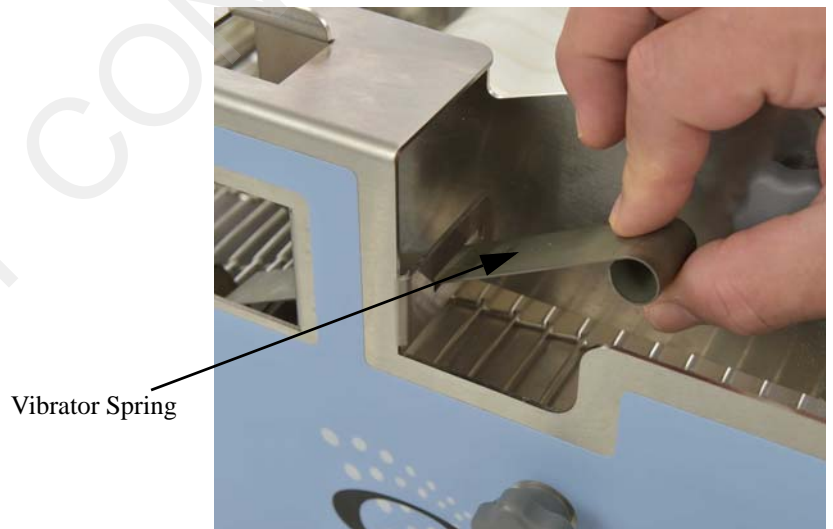
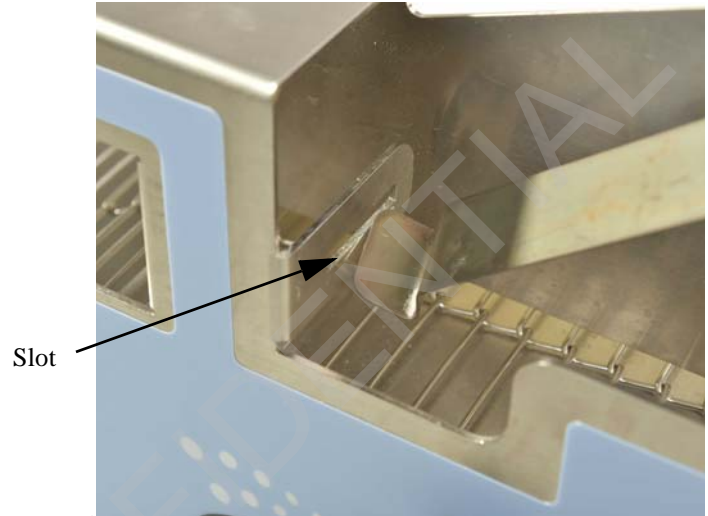

WIREBELT REPLACEMENT (CONTINUED)**Paddle Assembly**

- Install knob, shaft and paddles

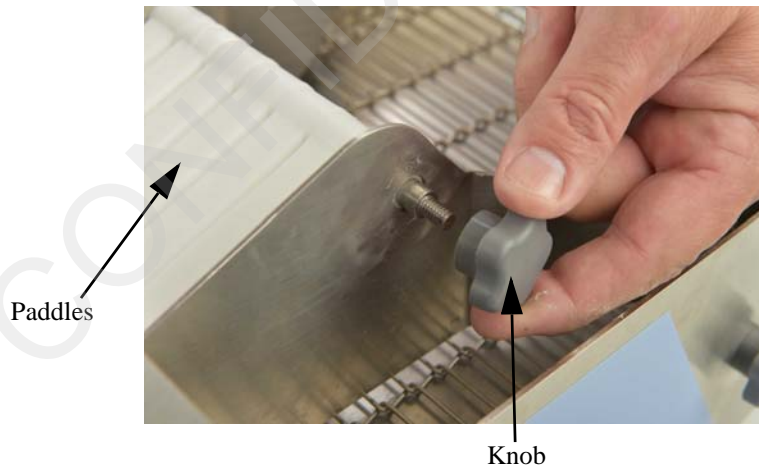



WIREBELT REPLACEMENT (CONTINUED)

Discharge Tray

- Position the bottom edge of discharge tray onto the bottom pan. Rotate discharge tray upward until it snaps into the breader conveyor side rails.

Discharge Tray

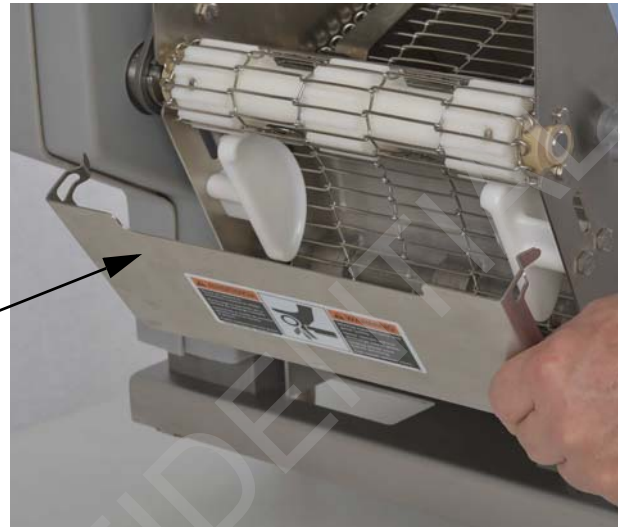

Pan Bracket

- Place the slots of the pan bracket onto the flange of the breader conveyor side rail.

Pan Bracket

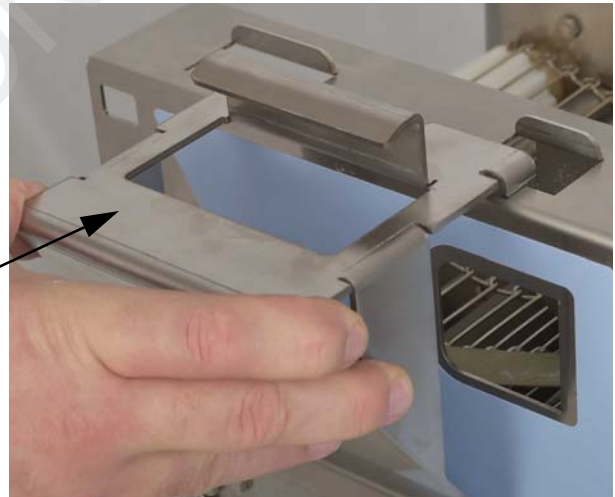



THIS PAGE INTENTIONALLY LEFT BLANK

COMPANY CONFIDENTIAL

Section 5C

Maintenance Frame Assembly

CONTENTS OF THIS SECTION

Safety Recommendations and Warnings	5C-2
Batter Drive Shaft/Bearing Replacement	5C-5
Breder Drive Shaft/Bearing Replacement	5C-11
Drive Chain Replacement	5C-23
Gear Motor Replacement	5C-26
On/Off Switch Replacement - BB-1	5C-31
Power Cord Replacement - BB-1	5C-35
On/Off Switch Replacement - BB-2	5C-42
Power Cord Replacement - BB-2	5C-46
On/Off Push Button Switch Replacement - BB-1F	5C-53
Power Cord replacement - BB-1F	5C-57



SAFETY RECOMMENDATIONS AND WARNINGS

 **WARNING**



All maintenance procedures should be performed by qualified personnel.

The information provided in these operating instructions is important to your health, comfort and safety. For safe and proper operation, read this entire manual before using this equipment.

Please read and save these instructions. Read carefully before attempting to assemble, install, operate or maintain this product. Protect yourself, others and equipment by observing all safety information. Failure to comply with instructions could result in personal injury and/or damage to the equipment. Any use in applications other than those for which the equipment was designed and built may result in equipment damage and/or serious injuries.

Retain this manual for future reference. Be thoroughly familiar with the controls and proper use of this equipment.

The manufacturer assumes no liability for any unauthorized changes in operating procedures or for unauthorized changes or modifications made to the design of the machine or any factory-installed safety equipment, whether these changes are made by the owner of this equipment, by his employees, or by service providers not previously approved by Bettcher Industries, Inc.

Use only replacement parts manufactured by Bettcher Industries, Inc. Use of substitute parts will void the warranty and may cause injury to operators and damage the equipment.

 **WARNING**



Electrical shock may occur! Always disconnect unit from power supply prior to servicing.

All electrical repairs should be completed by a qualified electrician or approved service provider.

SAFETY RECOMMENDATIONS AND WARNINGS (CONTINUED)



To avoid personal injury, guards must be in place while operating the machine.



Never operate without guards in place.

Moving machine parts and pinch points.
Never operate without discharge tray in place.

Sprocket and Chain

To avoid personal injury, guards must be in place while operating the machine.

COMPANY CONFIDENTIAL



THIS PAGE INTENTIONALLY LEFT BLANK

COMPANY CONFIDENTIAL

BATTER DRIVE SHAFT/BEARING REPLACEMENT

Step 1: Disassemble the frame assembly by removing:

- knobs
- locking latch (remove by aligning the tabs with the groove)
- drive guard covers

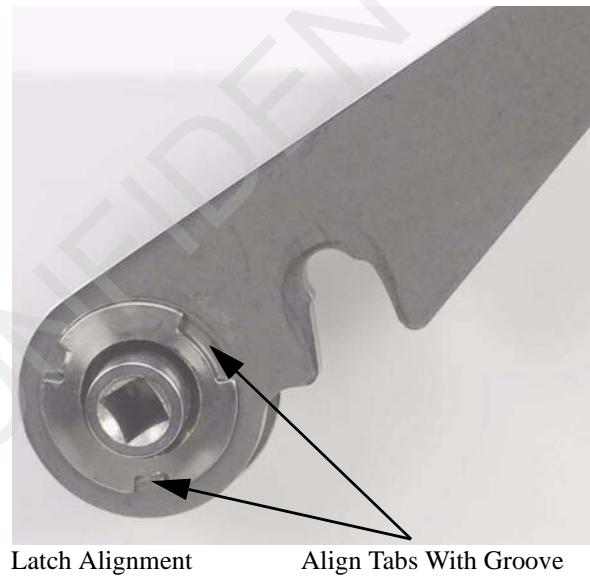
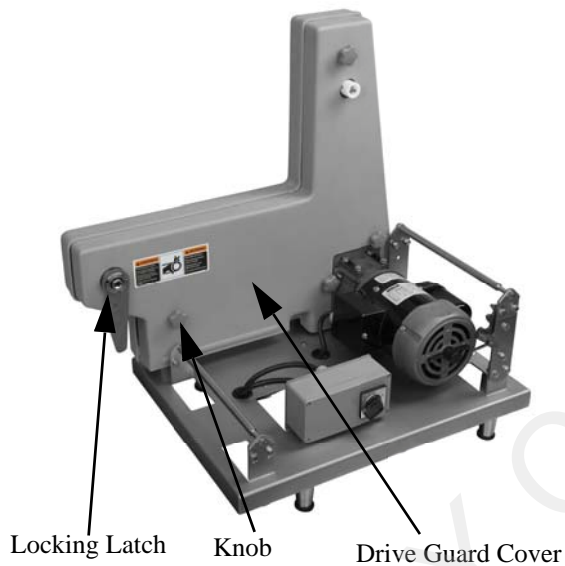



BATTER DRIVE SHAFT/BEARING REPLACEMENT (CONTINUED)

Step 2: Loosen the 4 motor mounting bolts and lift up the gear motor to loosen the drive chain. Slightly tighten one motor mounting bolt to position the gear motor in the upper most position.

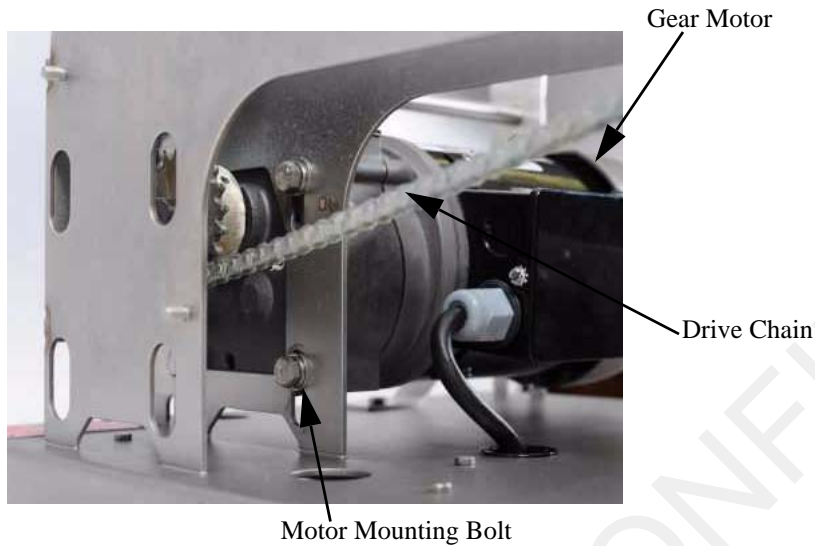

Step 3: Remove the guide sleeve by loosening the four guide sleeve set screws.



Set Screw

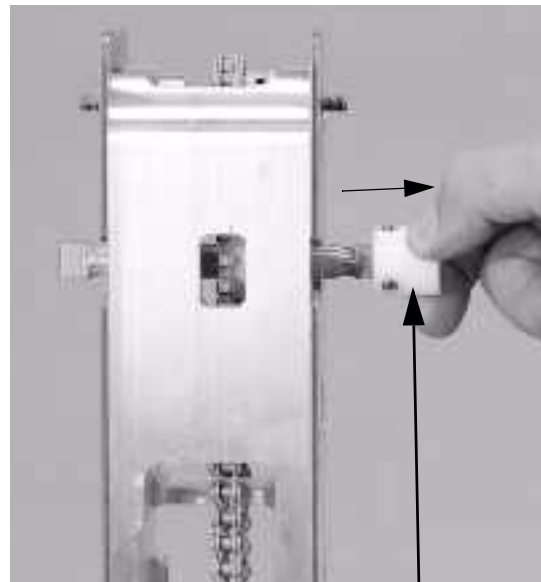

Guide Sleeve

BATTER DRIVE SHAFT/BEARING REPLACEMENT (CONTINUED)

Step 4: Using a 9/64" hex key, loosen the clamp collar screw and slide the collar away from the bearing.

Step 5: Using a 1/8" hex key, loosen the 2 drive sprocket set screws so that the batter drive shaft rotates freely inside the drive sprocket.

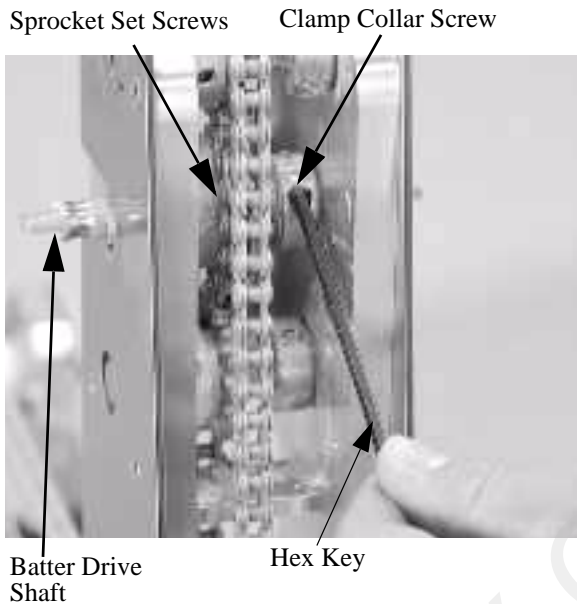

Step 6: Hold the drive sprocket and clamp collar while pulling the drive shaft out of the drive tower.

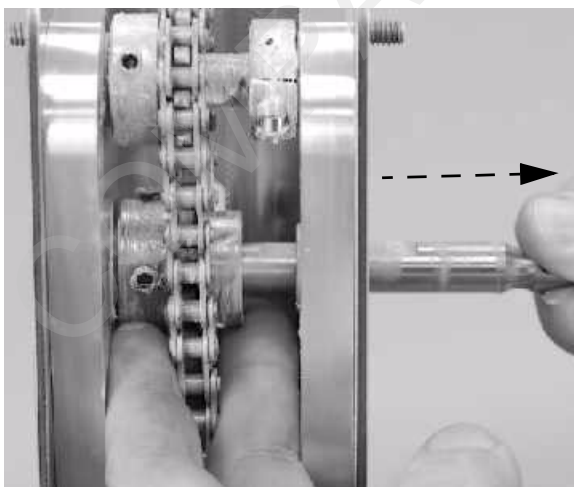



BATTER DRIVE SHAFT/BEARING REPLACEMENT (CONTINUED)

Step 7: Using a hammer and punch, remove the old bearings. Install the new bearings.



Remove

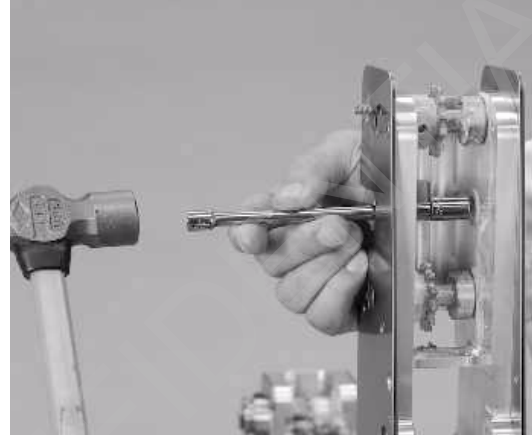

Install

Step 8: Slide the shaft through the frame and one bearing.

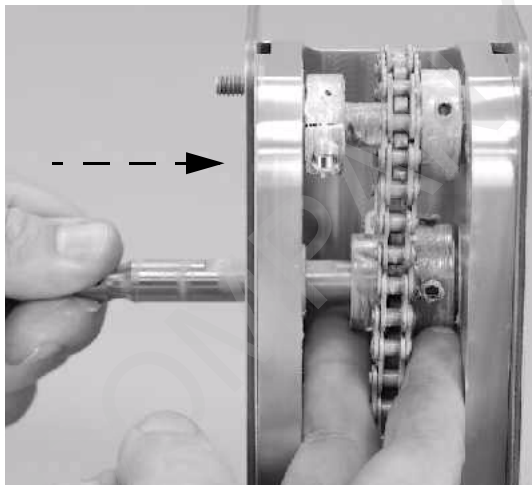

BATTER DRIVE SHAFT/BEARING REPLACEMENT (CONTINUED)

Step 9: Install the drive sprocket and clamp collar on the drive shaft. Make sure the chain is positioned on the drive sprocket. **Refer to the chain path view below.*

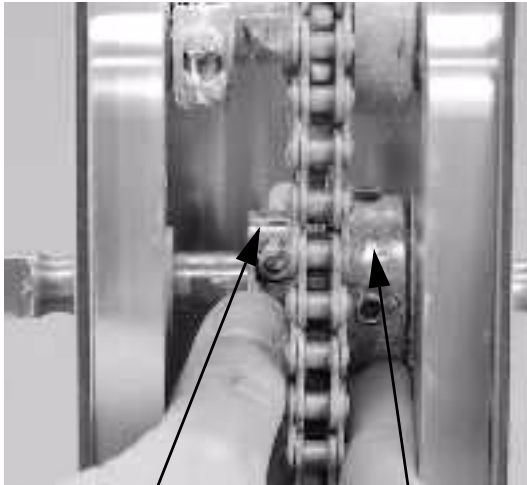

Clamp Collar Drive Sprocket

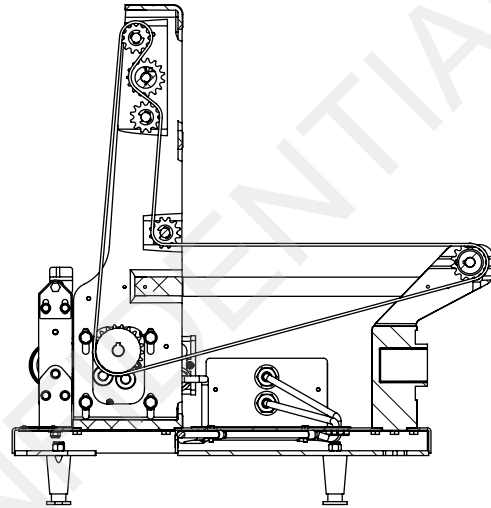

Step 10: Slide the drive sprocket against the bearing. Before tightening the sprocket set screws, check that the drive shaft is extended from the side of the frame approximately 13/16”.

IMPORTANT: *Make sure one of the sprocket set screws tighten on the flat part of the drive shaft.*

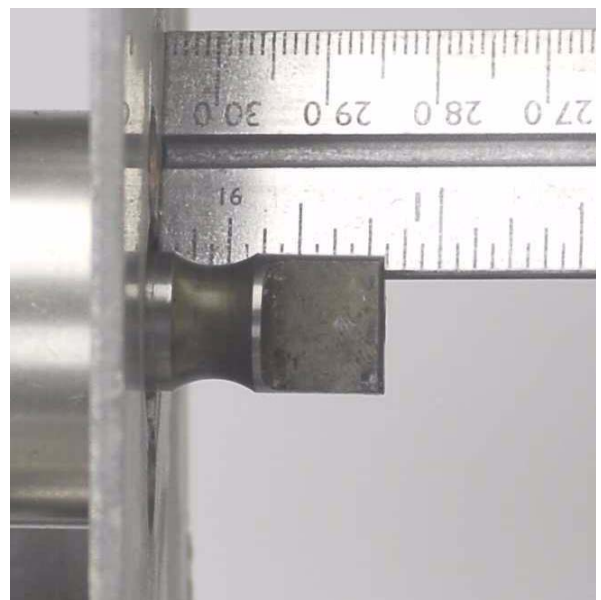
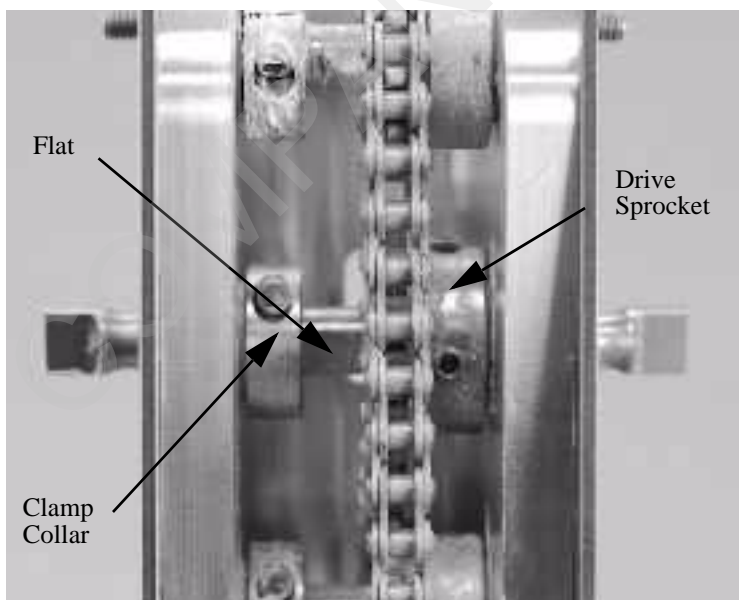



BATTER DRIVE SHAFT/BEARING REPLACEMENT (CONTINUED)

Step 11: Use a small piece of paper to create a shim. Place the shim between the clamp collar and the left side bearing. Slide the collar against the paper shim. Tighten the clamp collar screw then remove the paper shim.



Shim Clamp Collar

Step 12: The shaft assembly adjustment is correct if the shaft can be turned by hand and side to side movement is less than 1/64 of an inch (.4mm). Reinstall the guide sleeve.



Step 13: Adjust the drive chain tension by allowing the weight of the motor to tension the drive chain. To avoid over tensioning the drive chain, make sure the drive chain has 3/4" slack as shown. Tighten the 4 motor mounting bolts.

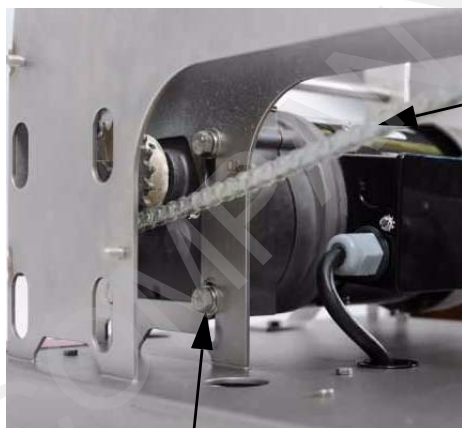

Motor Mounting Bolt

Drive Chain

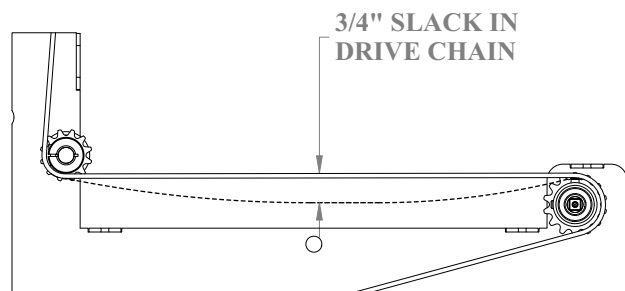

Step 14: Reinstall the drive guard covers, knobs, and locking latch. **For installation instructions, see Section 3 of this manual.*

BREADER DRIVE SHAFT/BEARING REPLACEMENT

Step 1: Disassemble the frame assembly by removing:

- knobs
- locking latch (remove by aligning the tabs with the groove)
- drive guard covers

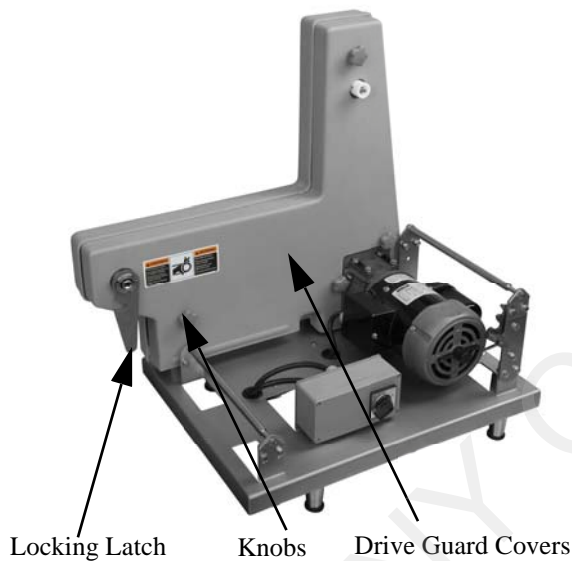

Latch Alignment





BREADER DRIVE SHAFT/BEARING REPLACEMENT (CONTINUED)

Step 2: Loosen the 4 motor mounting bolts and lift up the gear motor to loosen the drive chain. Slightly tighten one motor mounting bolt to position the gear motor in the upper most position.

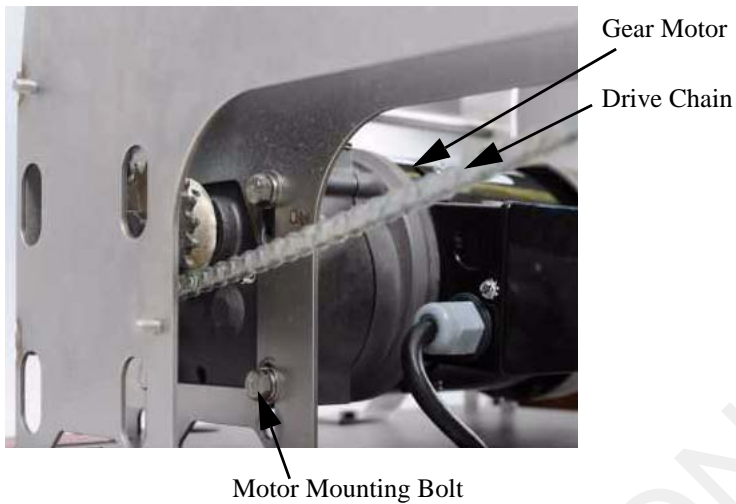

Step 3: Using a 5/16" wrench or flat tip screw driver, remove the coupler screw from the locking housing and remove the coupler.

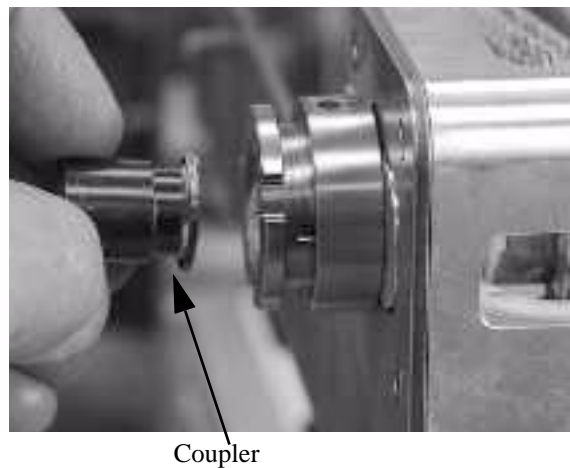
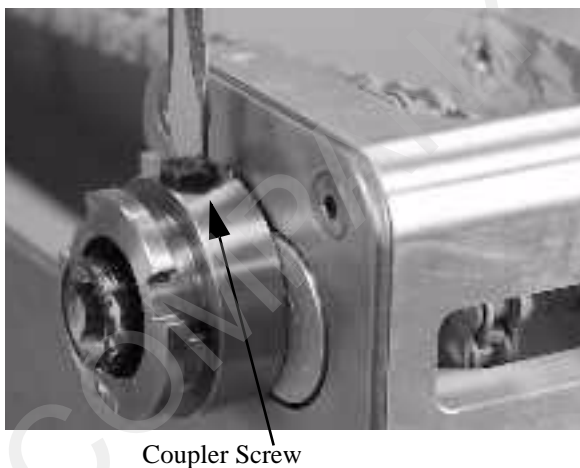

BREADER DRIVE SHAFT/BEARING REPLACEMENT (CONTINUED)

Step 4: Using a 7/64" hex key, remove the 2 screws from the split clamp and remove both clamp halves. Remove the retaining ring underneath.

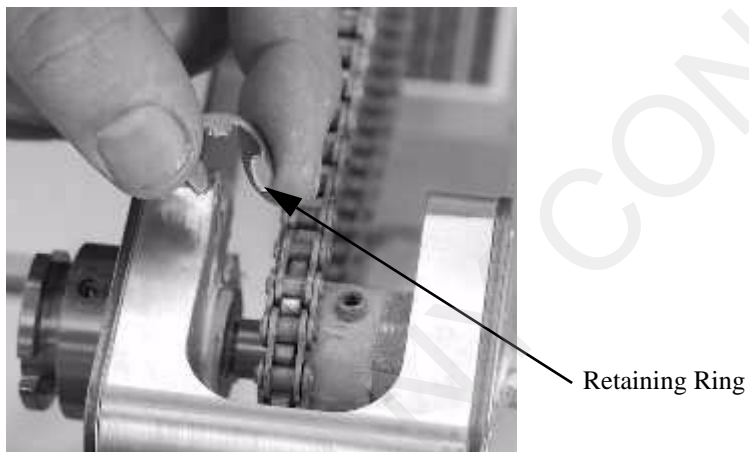
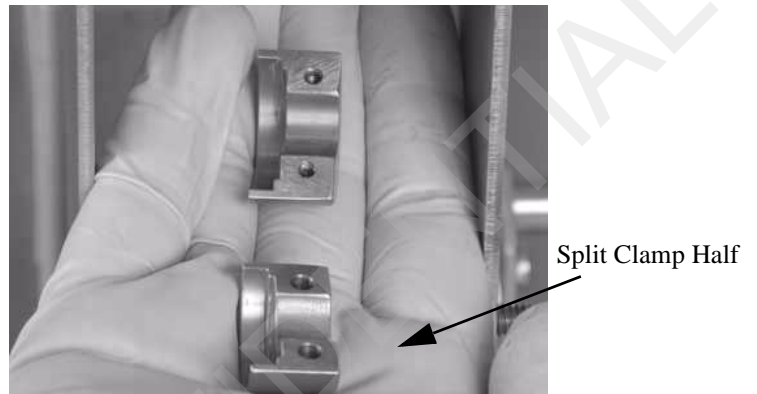
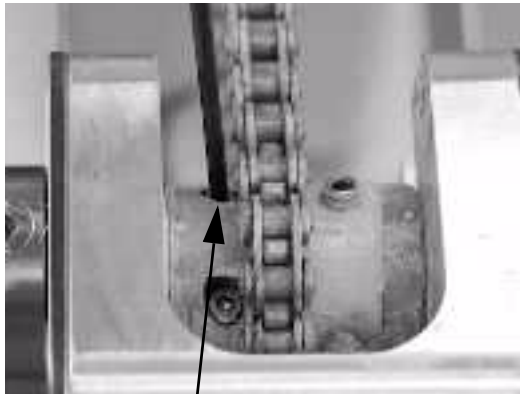

Step 5: Using a 1/8" hex key, loosen the 2 sprocket set screws.

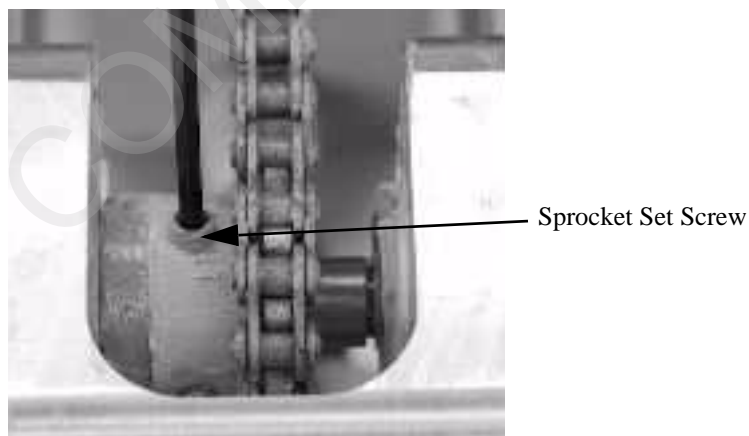



BREADER DRIVE SHAFT/BEARING REPLACEMENT (CONTINUED)

Step 6: Slide the sprocket over to expose the sprocket key and remove the key.

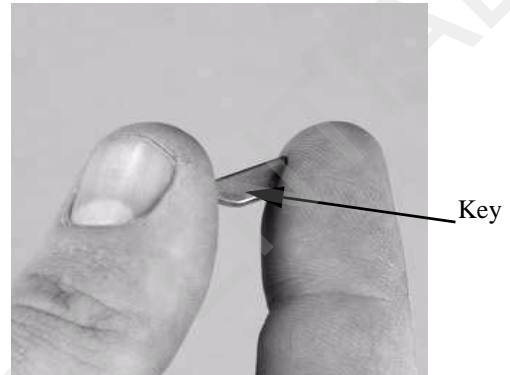
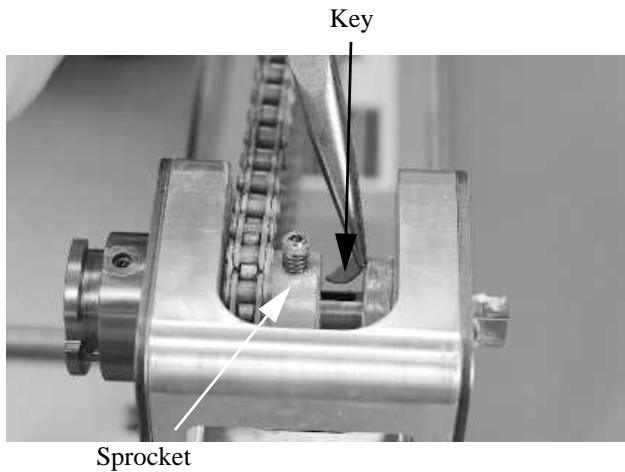

Step 7: Slide the spacer ring towards the sprocket to expose the retaining ring. Remove the retaining ring.

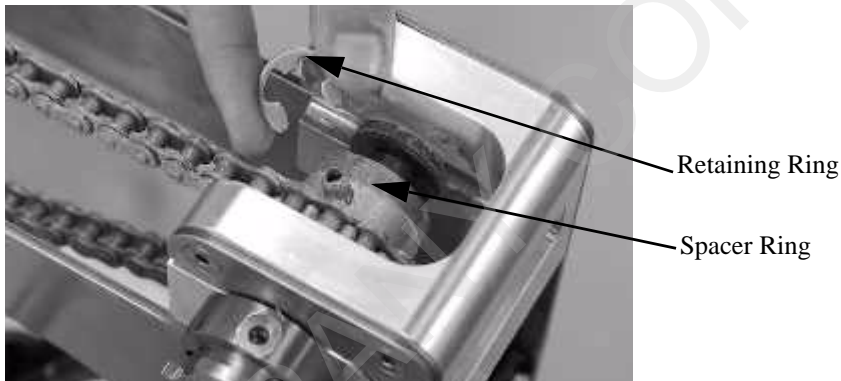

Step 8: Slide the drive shaft out of the bearing assemblies. While sliding the old shaft out, be certain to hold onto the loose components on the shaft (thrust bearings, thrust washer, spacer ring and drive sprocket) to prevent loss.





BREADER DRIVE SHAFT/BEARING REPLACEMENT (CONTINUED)

Step 9: Using a hammer and punch, remove the old bearings.

Step 10: Install the new bearings.



NOTICE

When installing the screws, use thread locker (Loctite 242 or equivalent).

Step 11: Insert the drive shaft into the left side of the locking housing and bearing.

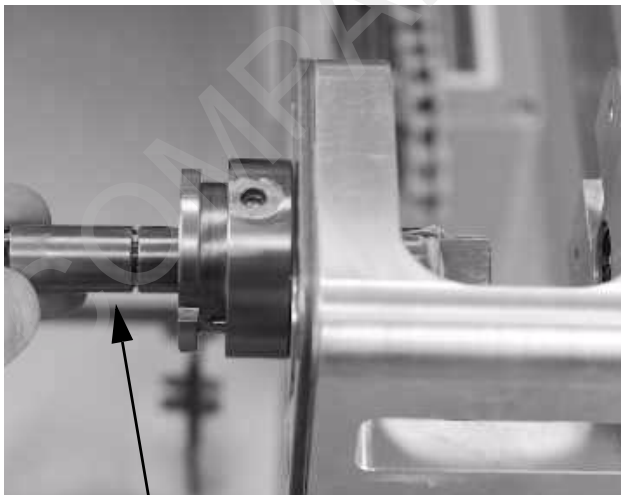

Drive Shaft



BREADER DRIVE SHAFT/BEARING REPLACEMENT (CONTINUED)

Step 12: While inserting the drive shaft, slip thrust washers (silver), thrust bearings (gold), spacer ring and sprocket over the exposed end of the shaft. If any of these components require replacement, do so before moving on to the next step.

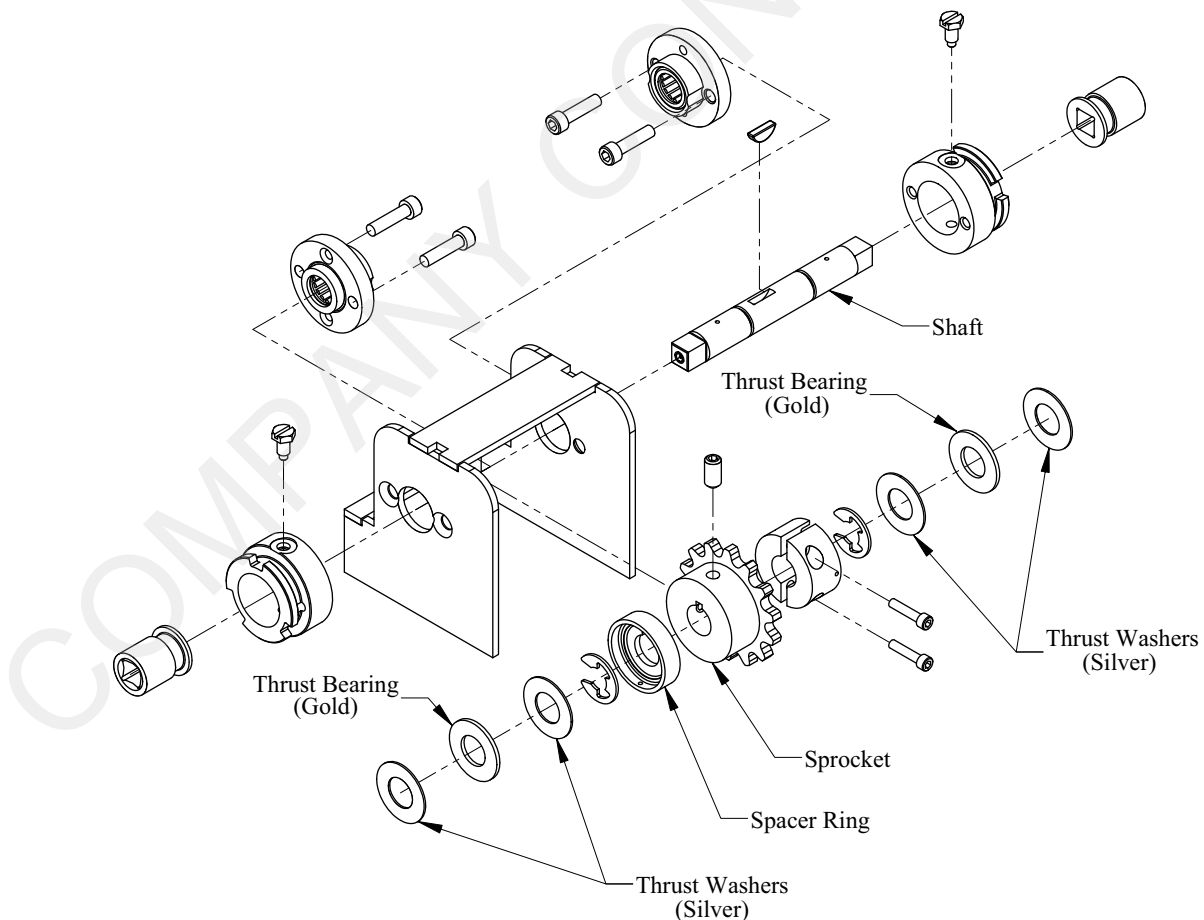
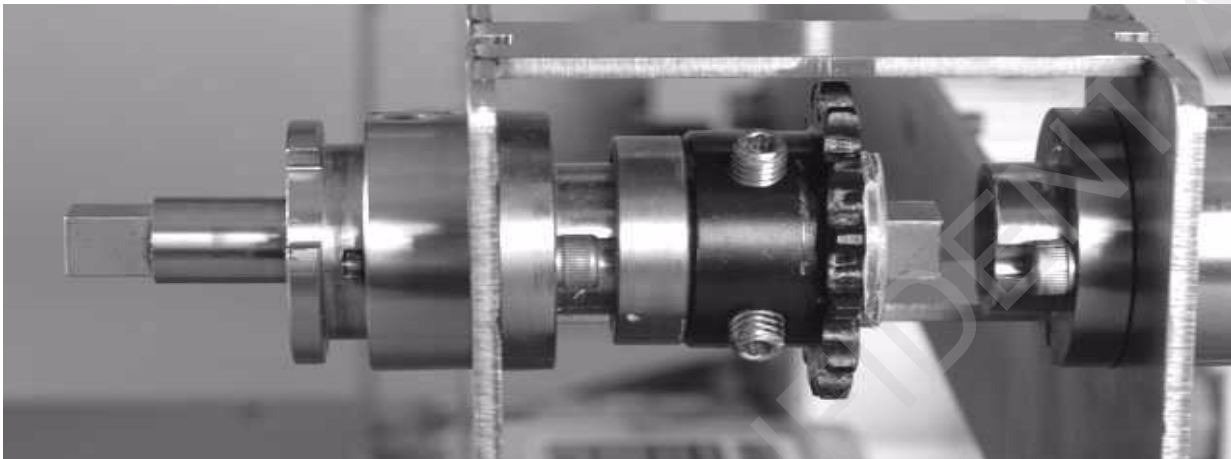

BREADER DRIVE SHAFT/BEARING REPLACEMENT (CONTINUED)

Step 13: *Make certain the drive chain is correctly looped over the sprocket, then push the drive shaft through so that both retaining ring grooves are visible.

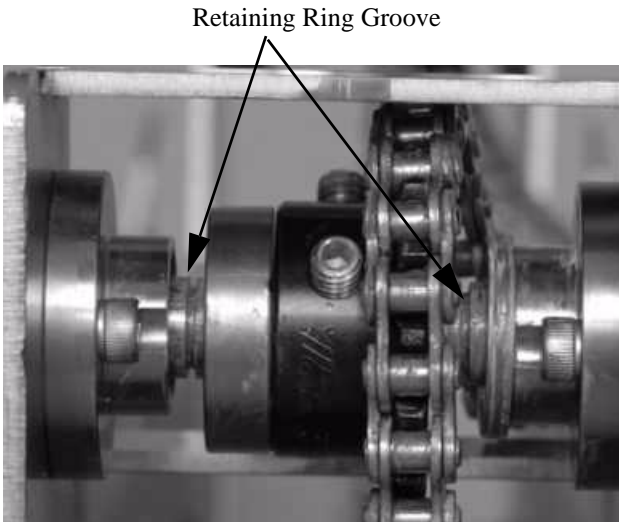

Step 14: Slide the sprocket and the spacer ring away from each other, exposing the key slot.

Step 15: Install the sprocket key into the **left** most key slot of the drive shaft.

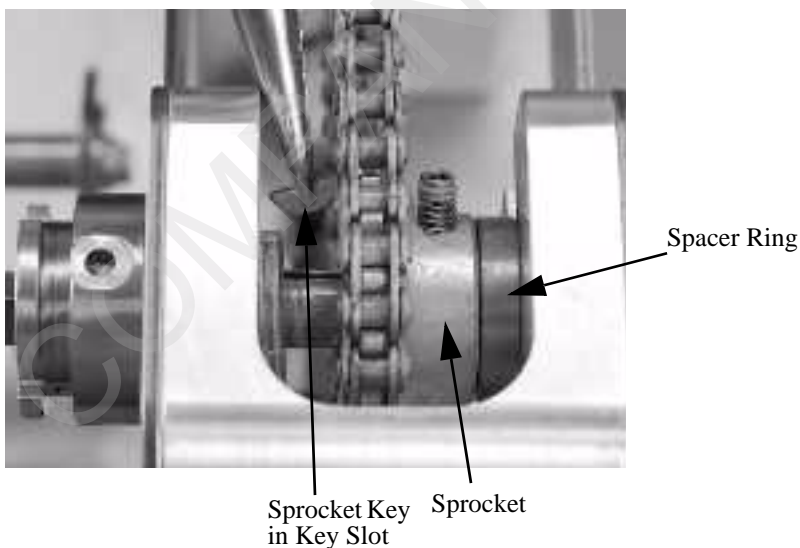



BREADER DRIVE SHAFT/BEARING REPLACEMENT (CONTINUED)

Step 16: Slide the spacer ring towards the sprocket to expose the retaining ring groove. Be sure that the thrust washers (silver) and the thrust bearing (gold) are properly installed (See diagram below). Install the retaining ring.

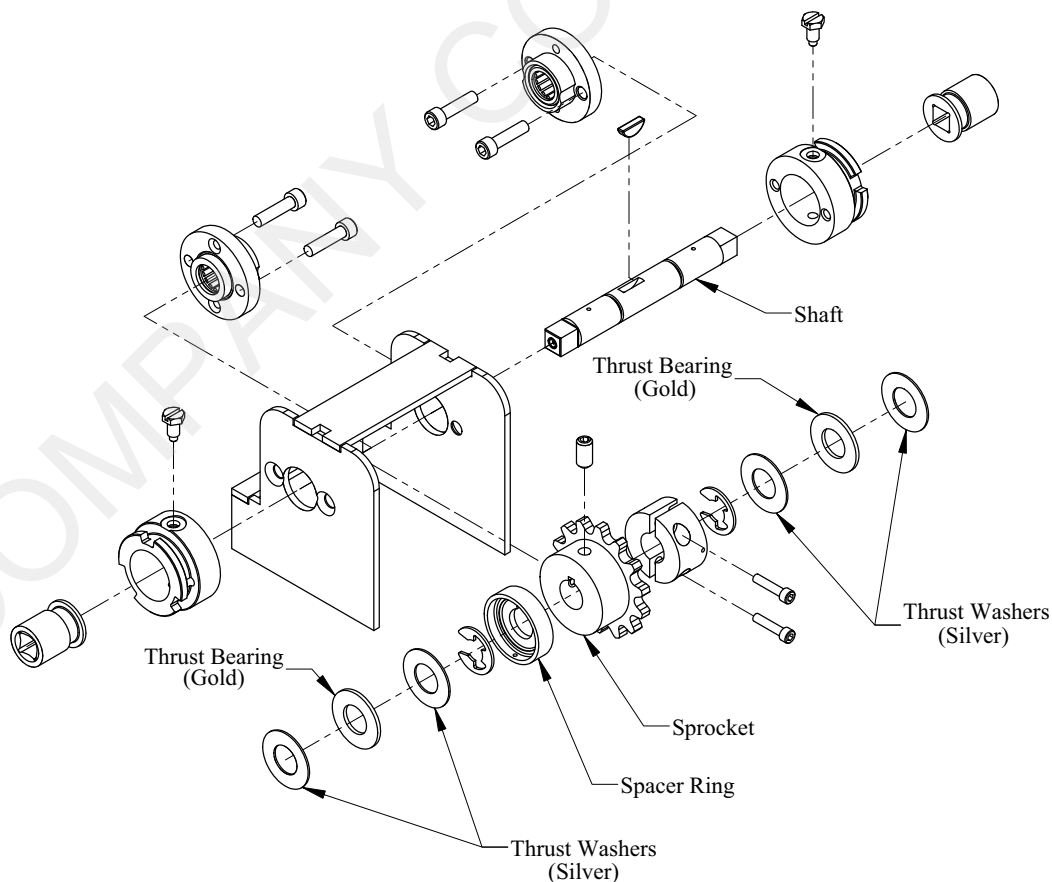
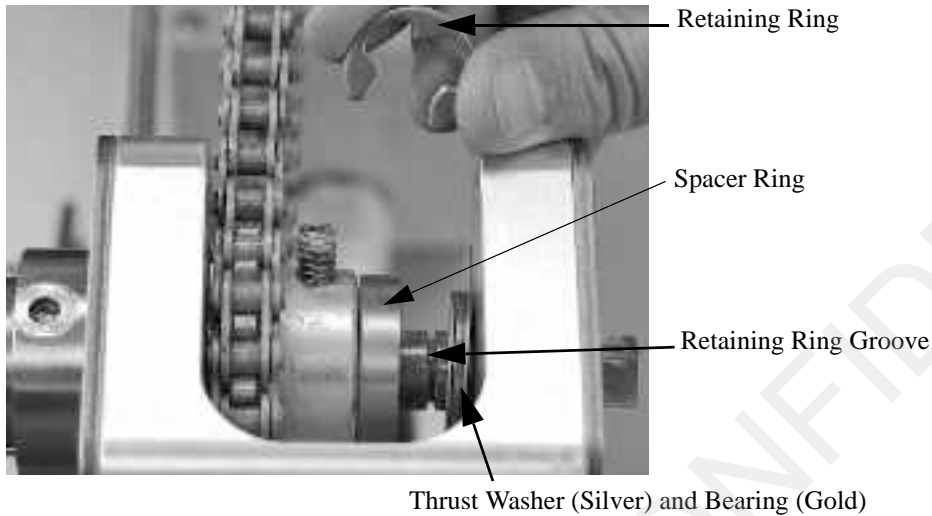

BREADER DRIVE SHAFT/BEARING REPLACEMENT (CONTINUED)

Step 17: Slide the spacer ring to the left side until it stops on the retaining ring.

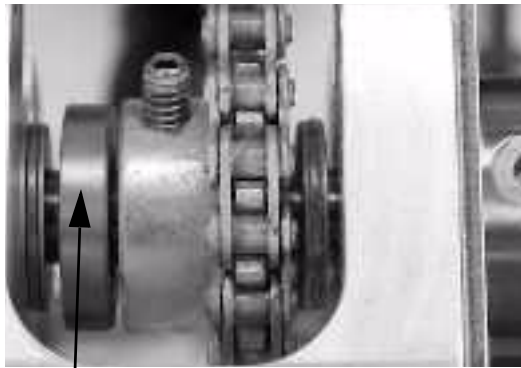

Spacer Ring to the left

Step 18: Slide the sprocket to the left until it stops on the spacer ring. Make sure that the sprocket's keyway lines up with the key in the shaft. Tighten the set screws. Install the retaining ring into the groove.

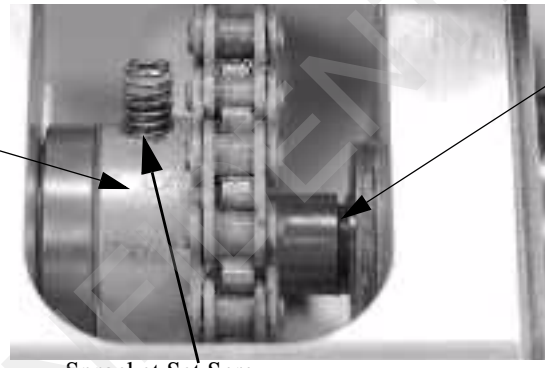

Sprocket to the left

Sprocket Set Screw

Groove

Step 19: Install the split collar halves around the shaft. Slide the split collar against the retaining ring. Apply thread locker (Loctite 242 or equivalent) to the 2 screws. Tighten the screws, using a 5/64" hex key. Once assembled, the collar must rest against the retaining ring on the right side of the shaft. **Do not rest it against the sprocket.*

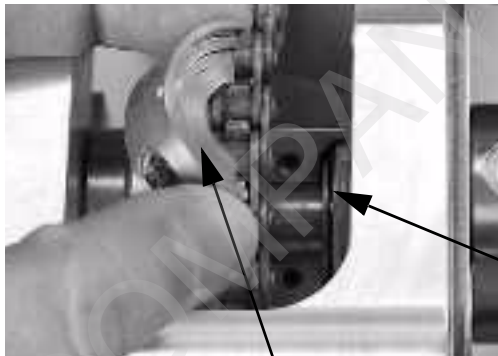

Retaining Ring

Split Collar



BREADER DRIVE SHAFT/BEARING REPLACEMENT (CONTINUED)

Step 20: Reinstall coupler and coupler screw.

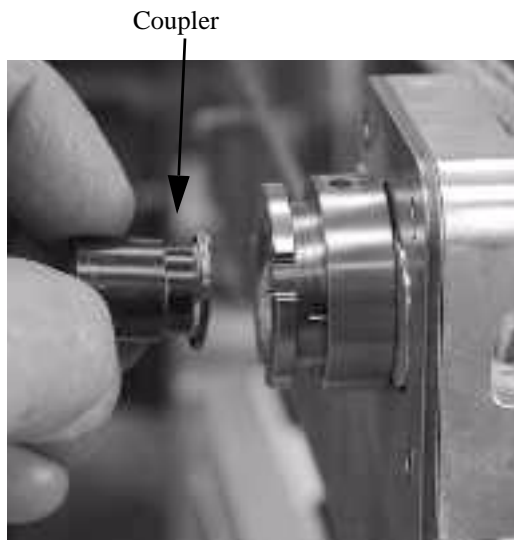

Step 21: Ensure that the drive chain is routed around the sprockets as shown in the diagram.

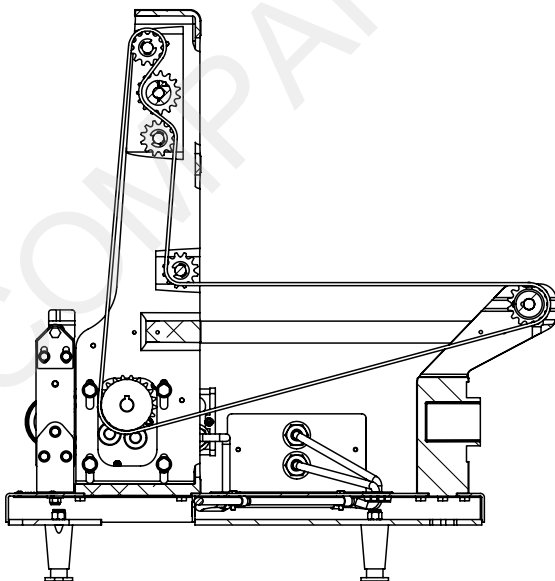

BREADER DRIVE SHAFT/BEARING REPLACEMENT (CONTINUED)

Step 22: Adjust the drive chain tension by allowing the weight of the motor to tension the drive chain. To avoid over tensioning the drive chain, make sure the drive chain has 3/4" slack as shown. Tighten the 4 motor mounting bolts.

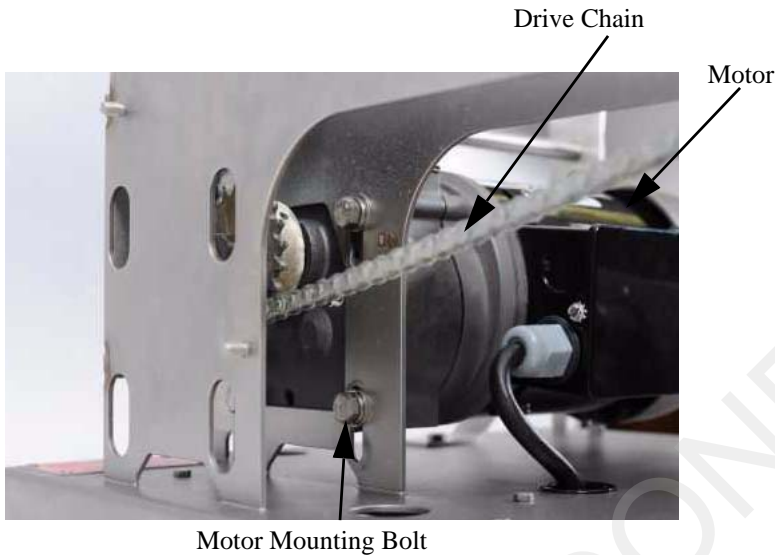

Step 23: Verify the drive chain tension by pressing down on the chain as shown. Drive chain deflection should be 3/4 of an inch.

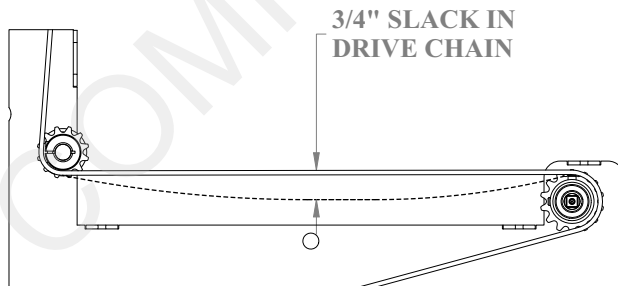



BREADER DRIVE SHAFT/BEARING REPLACEMENT (CONTINUED)

Step 24: Grease the breader drive shaft by using the grease gun (PN: 501417) to pump the grease into the grease fittings in the drive shaft and into the fill ports in the spacer ring and split collar. Regrease the bearings every six months.

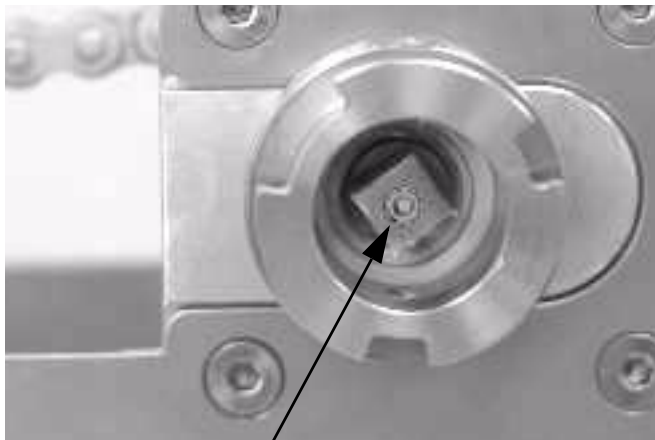

Grease Fitting

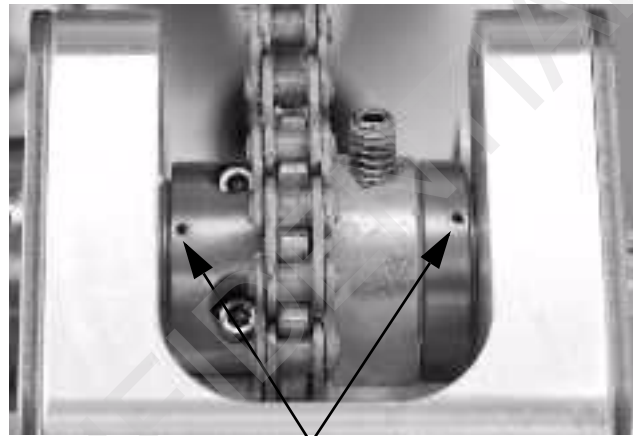

Fill Ports

Step 25: Reinstall the drive guard covers, knobs, and locking latch. **For installation instructions, see Section 3 of this manual.*



DRIVE CHAIN REPLACEMENT

Step 1: Disassemble the frame assembly by removing:

- knobs
- locking latch (remove by aligning the tabs with the groove)
- drive guard covers

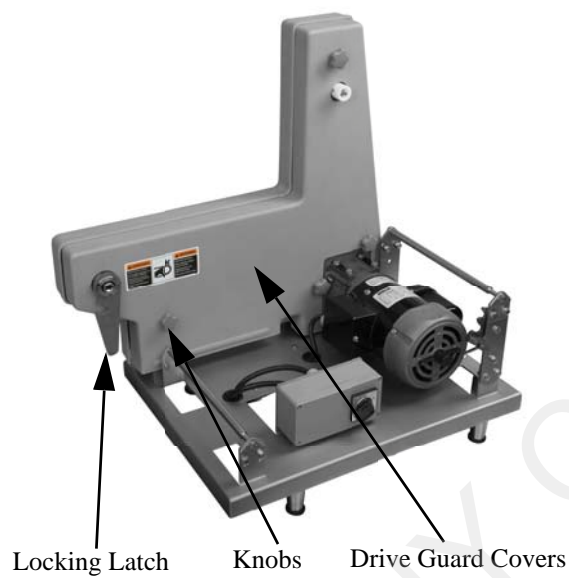

Latch Alignment





DRIVE CHAIN REPLACEMENT (CONTINUED)

Step 2: Loosen the 4 motor mounting bolts and lift up the gear motor to loosen the drive chain. Slightly tighten one motor mounting bolt to position the gear motor in the upper most position.

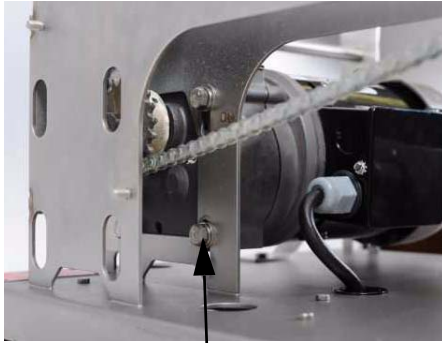

Motor Mounting Screw

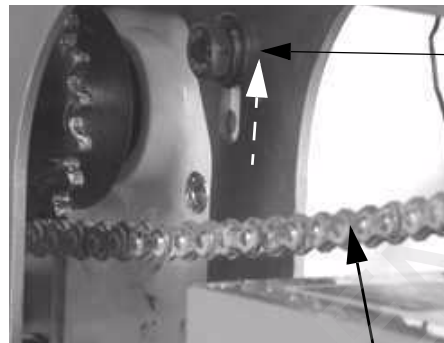

Upper Most Position

Drive Chain

Step 3: Remove the master link retaining clip, master link spacer and slide the master link out.

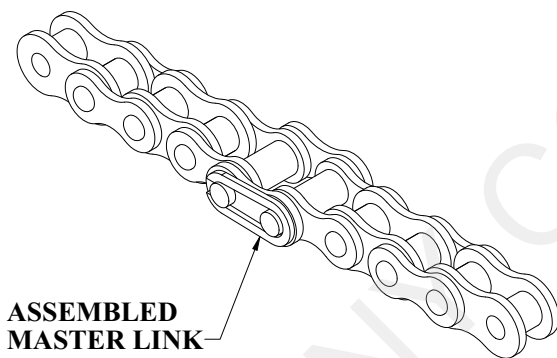

ASSEMBLED MASTER LINK

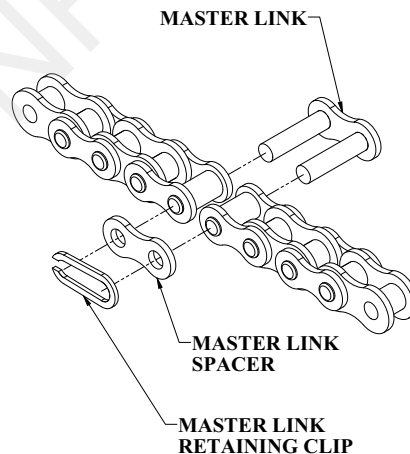

Step 4: Remove the old drive chain. Install the new drive chain around the sprockets as shown. Reinstall the master link.

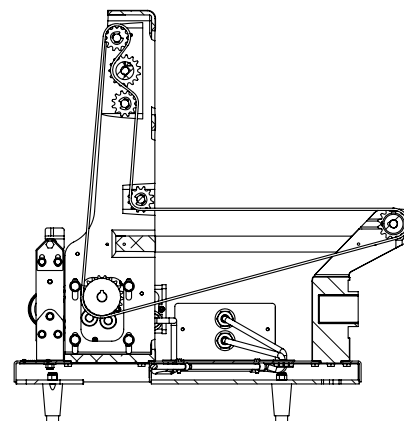

DRIVE CHAIN REPLACEMENT (CONTINUED)

NOTICE

Verify that the drive chain path is correct.

Step 5: Adjust the drive chain tension by allowing the weight of the motor to tension the drive chain. To avoid over tensioning the drive chain, make sure the drive chain has 3/4" slack as shown. Tighten the 4 motor mounting bolts.

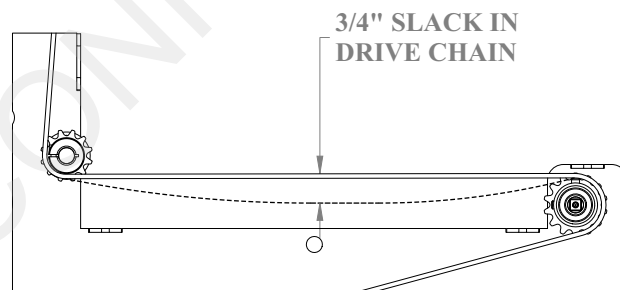
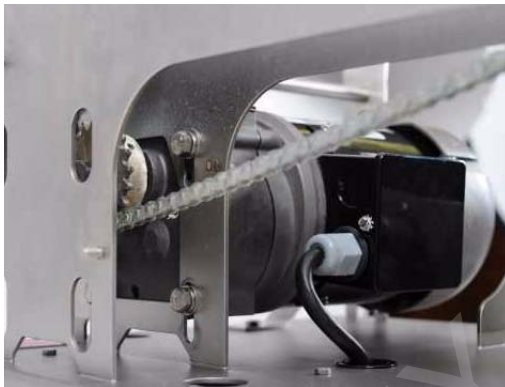

Step 6: Reinstall the drive guard covers, knobs, and locking latch. **For installation instructions, see Section 3 of this manual.*



GEAR MOTOR REPLACEMENT

WARNING

Electrical shock may occur! Always disconnect unit from power supply prior to servicing.



All electrical repairs should be completed by a qualified electrician or approved service provider.

Step 1: Disassemble the frame assembly by removing:

- knobs
- locking latch (remove by aligning the tabs with the groove)
- drive guard covers

Step 2: Using a screw driver or a 1/4" nut driver, remove the motor junction box cover by loosening the screws on each side.

Step 3: Remove the screw and washer that secure the green ground wire to the motor housing.

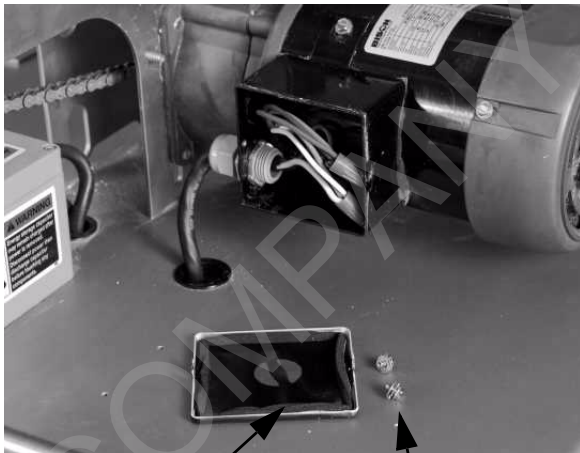

Junction Box
Cover

Screws

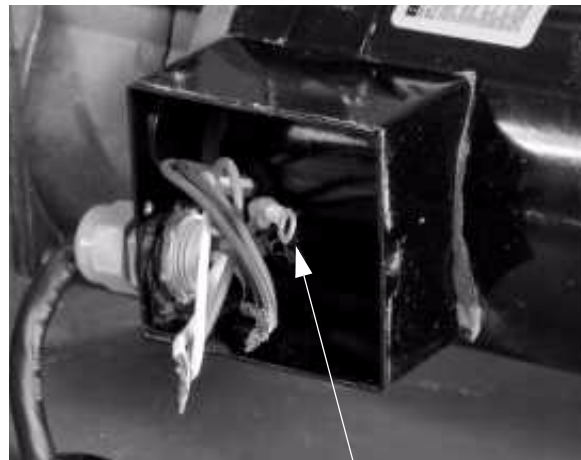

Green Ground Wire

GEAR MOTOR REPLACEMENT (CONTINUED)

Step 4: Remove and save the wire nuts connecting the motor cord wire to the motor wires. *See the electrical schematics in Section 7.*

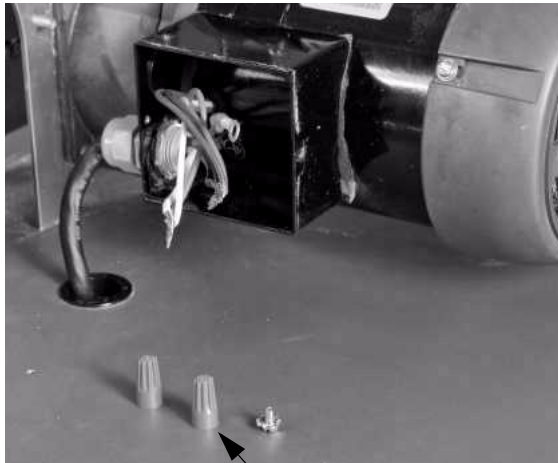

Wire Nuts

Step 5: Remove and save the locknuts that hold the connectors into the junction box. Pull the motor cord and connector from the junction box.



Motor Cord

Lock Nut

Step 6: Remove the gear motor by removing the mounting screws and washers that attach it to the frame. When removing, raise the motor high enough to slacken and unhook the drive chain from the motor sprocket. **Save the gear motor mounting screws for reassembly.*

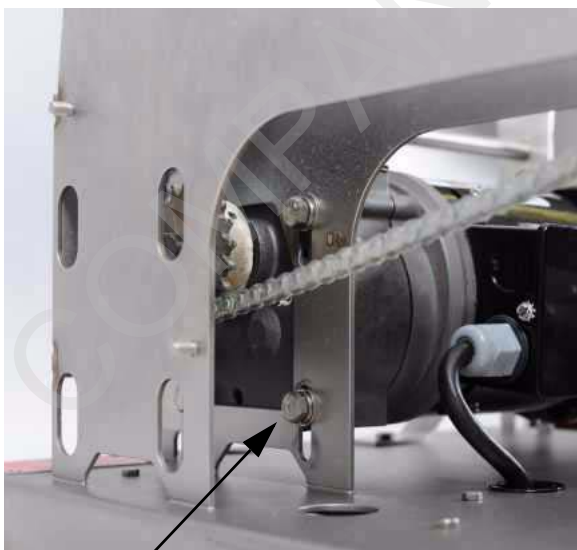

Motor Mounting Screw



GEAR MOTOR REPLACEMENT (CONTINUED)

Step 7: Loosen the 2 set screws located in the gear motor drive sprocket. Remove the gear motor drive sprocket from the shaft. **This sprocket is keyed to the gear motor shaft and may require a gear puller to remove.*

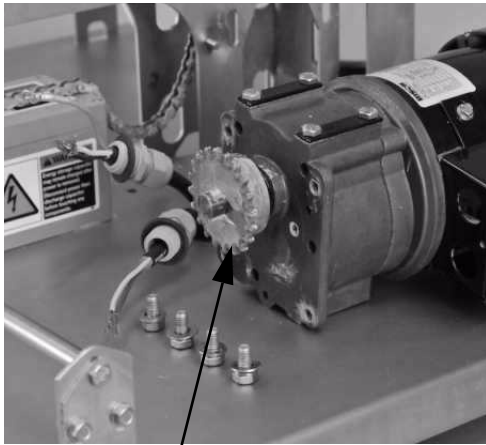

Gear Motor Drive Sprocket

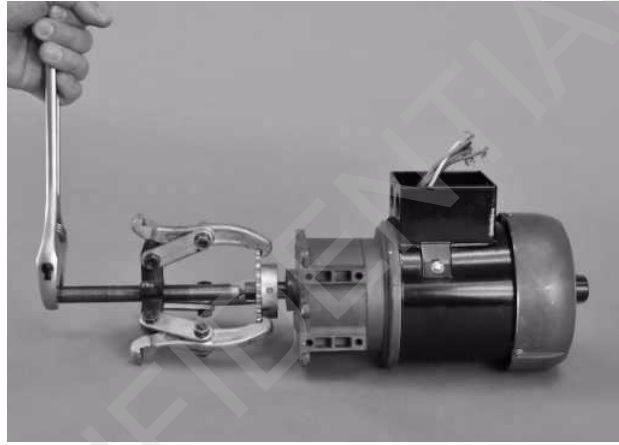

Step 8: Install the gear motor drive sprocket onto the new motor. Install with the sprocket hub facing the gear motor. Align the sprocket keyway with the gear motor shaft key.

Step 9: Position the inside edge of the gear motor drive sprocket 11/16 on an inch (17.5mm) from the motor housing and tighten the set screws.

New Gear Motor

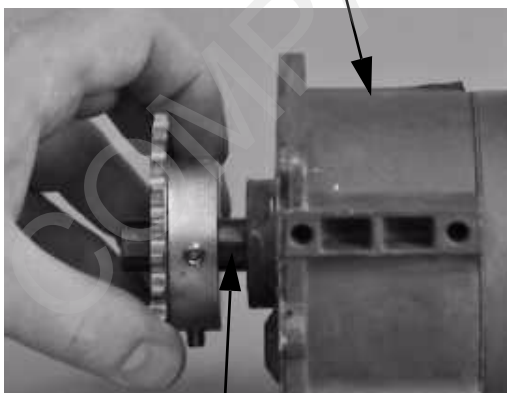

Gear Motor Shaft Key

1-3/8" Center of Teeth

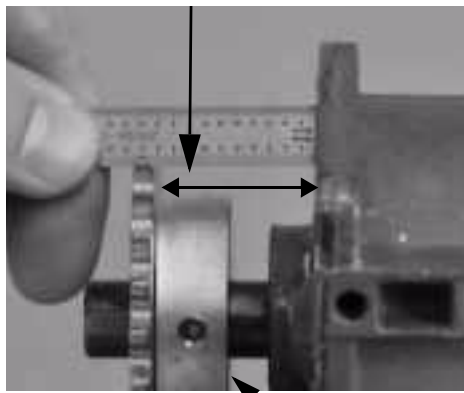

Hub

GEAR MOTOR REPLACEMENT (CONTINUED)

Step 10: Remove the new motor junction box cover by loosening the screws on each side. Insert the motor cord and strain relief into the bottom hole in the motor junction box and secure it with a lock nut. Fasten the ground (green) wire to the motor housing inside the junction box with the provided screw and washer.



Motor Cord installed in the bottom hole of junction box

Step 11: Connect the motor switch cord wires together, using the wire nuts. **See the electrical schematic in Section 7.*

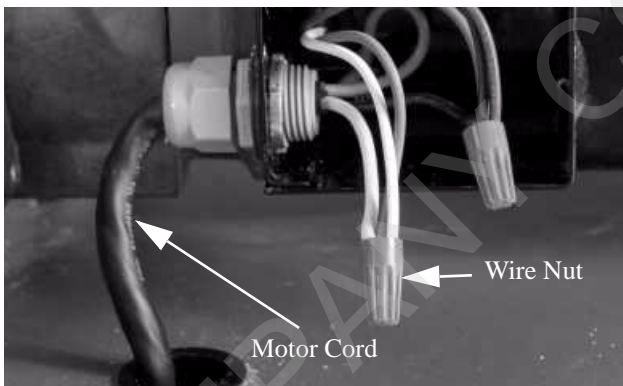

Step 12: Using a screwdriver or a 1/4" nut driver, install the junction box cover, securing it with the shake proof washers and screws provided with the new motor.

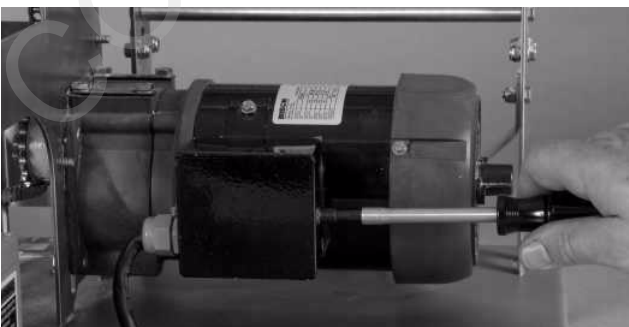



GEAR MOTOR REPLACEMENT (CONTINUED)

Step 13: Set the motor into the frame tower and engage the chain with the motor sprocket. Install the gear motor mounting bolts and washers. **Do not tighten.* Lower the gear motor and allow the weight of the motor to tension the drive chain.

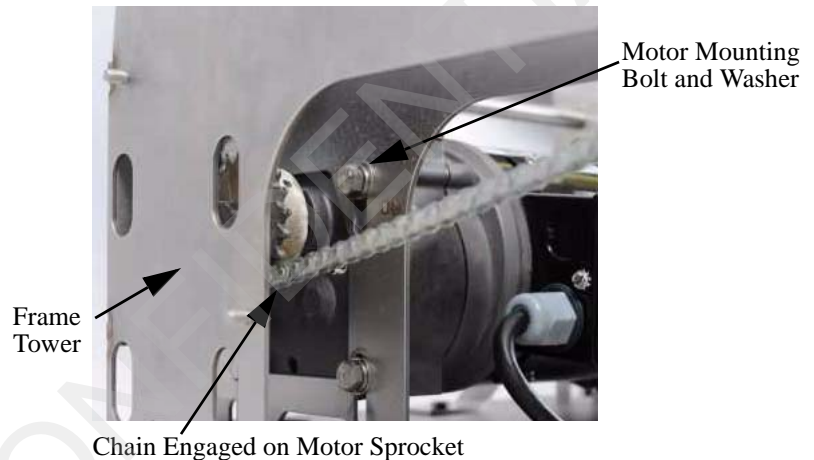
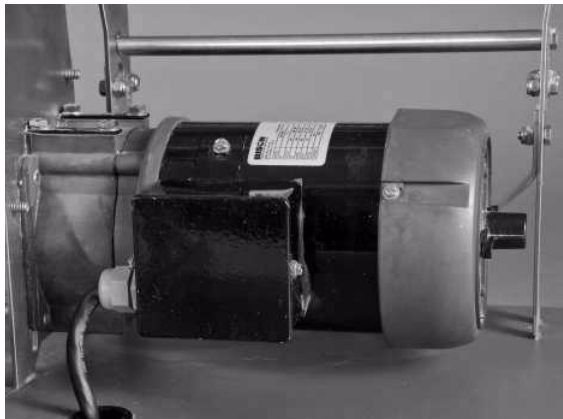

Step 14: Adjust the drive chain tension by allowing the weight of the motor to tension the drive chain. To avoid over tensioning the drive chain, make sure the drive chain has 3/4" slack as shown. Tighten the 4 motor mounting bolts.

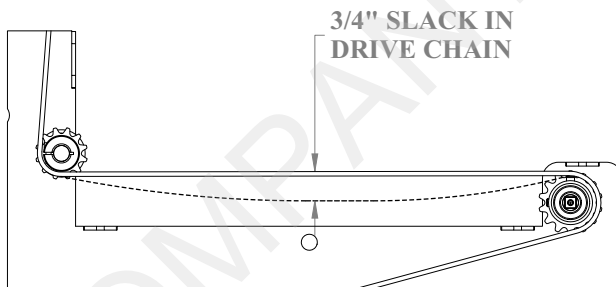

Step 15: Reinstall the drive guard covers, knobs, and locking latch. **For installation instructions, see Section 3 of this manual.*

ON/OFF SWITCH REPLACEMENT - BB-1

Step 1: Disassemble frame assembly by removing:

- knobs
- locking latch (remove by aligning the tabs with the groove)
- drive guard covers



Latch Alignment





ON/OFF SWITCH REPLACEMENT - BB-1 (CONTINUED)

! WARNING

Electrical shock may occur! Always disconnect unit from power supply prior to servicing.



All electrical repairs should be completed by a qualified electrician or approved service provider.

Step 2: Remove the 4 screws that attach the power switch assembly.



Step 3: Pull the power switch out of the power switch box and disconnect the two black wires from the back of the switch by loosening the retaining screws.

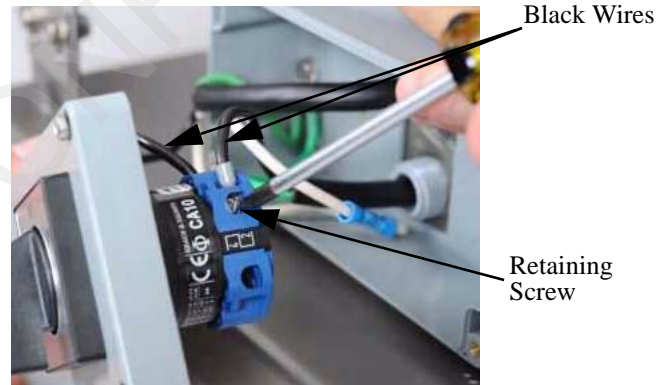

Step 4: Remove the power switch assembly from the switch body by releasing the red lever.

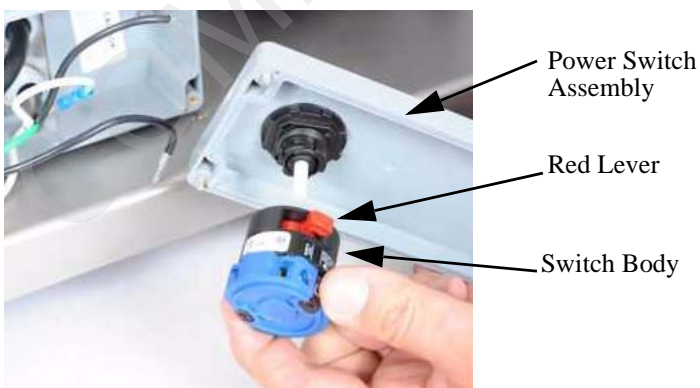

ON/OFF SWITCH REPLACEMENT - BB-1 (CONTINUED)

Step 5: Remove the switch lever from the switch plate by removing the locking ring on the rear of the switch plate.

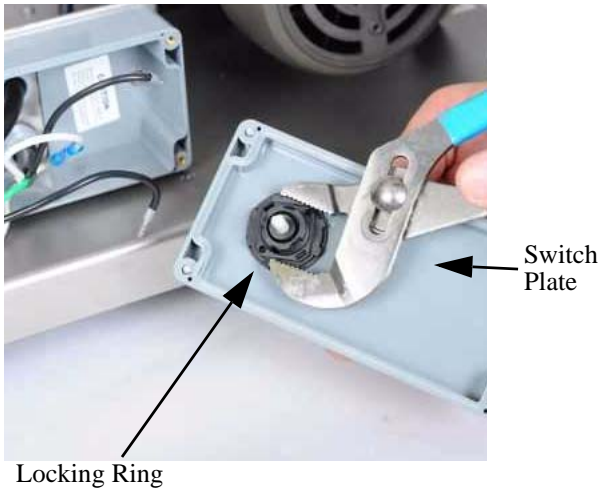

Step 6: Install the new switch lever into the switch plate, aligning the tab on the switch knob with the cut out in the switch plate.



Step 7: Install the locking ring and tighten.



Step 8: Install the new switch body and secure it with the red lever.

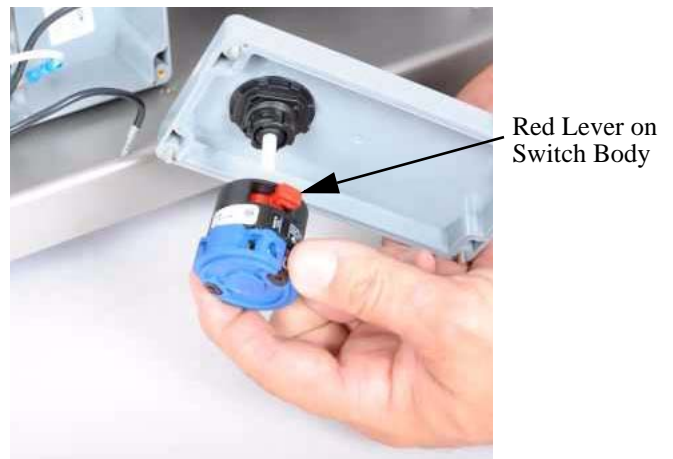



ON/OFF SWITCH REPLACEMENT - BB-1 (CONTINUED)

Step 9: Install the two black wires and tighten the retaining screws. *See electrical schematics in Section 7.

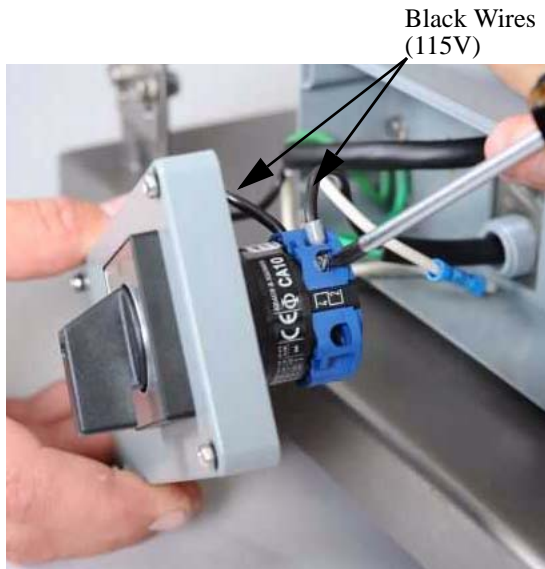

Step 10: Install the 4 screws attaching the power switch assembly to the frame.

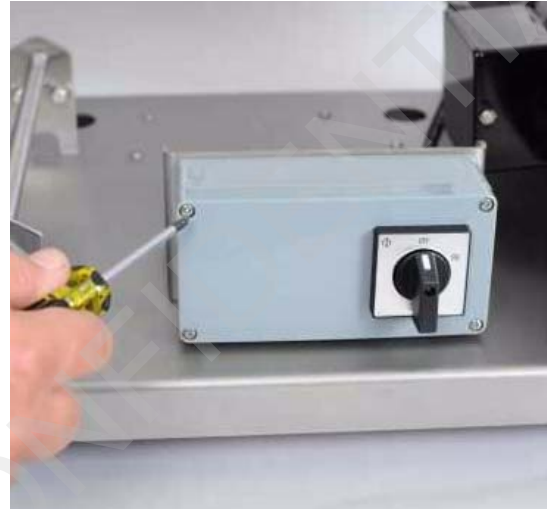

Step 11: Reinstall the drive guard covers, knobs, and locking latch.

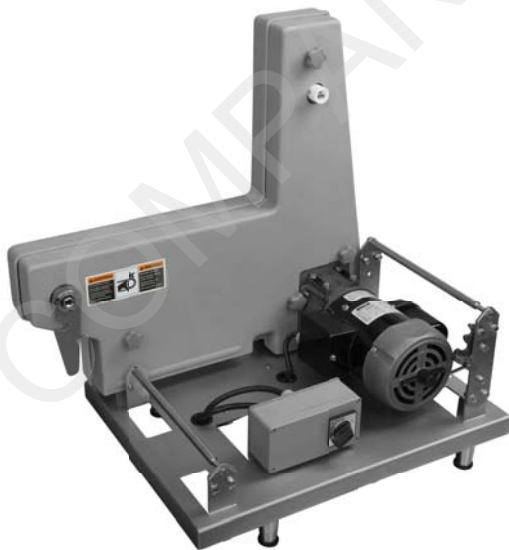

POWER CORD REPLACEMENT - BB-1

Step 1: Disassemble frame assembly by removing:

- knobs
- locking latch (remove by aligning the tabs with the groove)
- drive guard covers

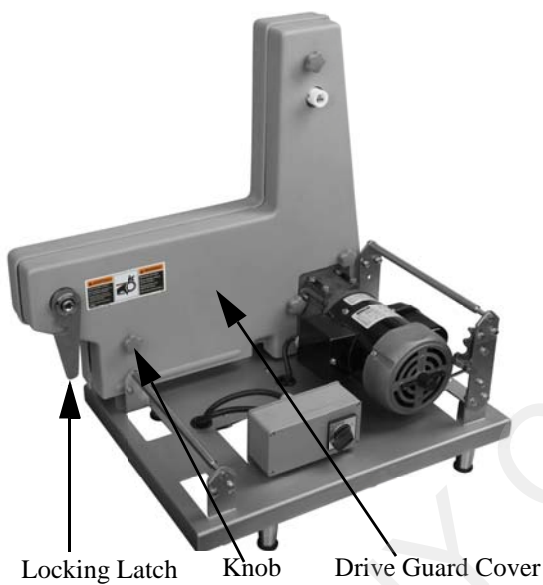



POWER CORD REPLACEMENT - BB-1 (CONTINUED)

! WARNING

Electrical shock may occur! Always disconnect unit from power supply prior to servicing.



All electrical repairs should be completed by a qualified electrician or approved service provider.

Step 2: Remove the 4 screws that attach the power switch assembly.



Step 3: Pull the power switch out of the power switch box and disconnect the wires from the back of the switch by loosening the retaining screws.

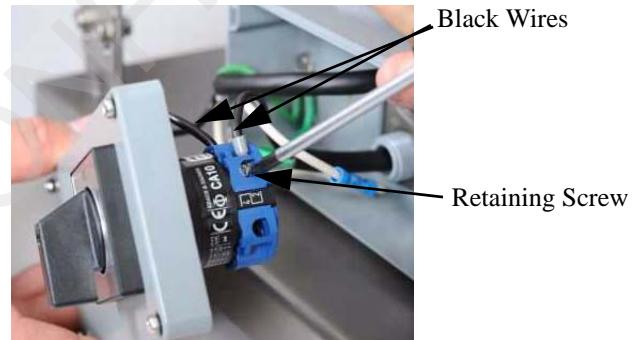

Step 4: Remove the power cord ground wire screw from the inside of the power switch box by using a 5/16" nut driver.



POWER CORD REPLACEMENT - BB-1 (CONTINUED)

Step 5: The power cord neutral (white) wire is spliced to the motor cord wire (white). Remove the splice by cutting the white wires on either side of the splice. Strip the end of the motor cord's white wire.

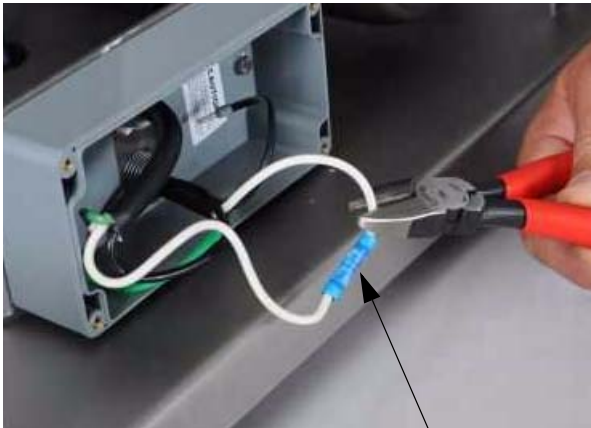

Splice



POWER CORD REPLACEMENT - BB-1 (CONTINUED)

Step 6: Loosen the connector's top cap retaining the power cord. Pull the power cord out of the connector.



Connector's Top Cap

Step 7: Turn the frame on its back, so that the cords are visible. Remove the three nuts, washers and cable clamps that hold the power cord.



Underside Of Frame

Step 8: From the underside of the frame, use a screwdriver to push out the power cord strain relief bushing. If the strain relief bushing is not damaged, save for reuse on the new power cord.

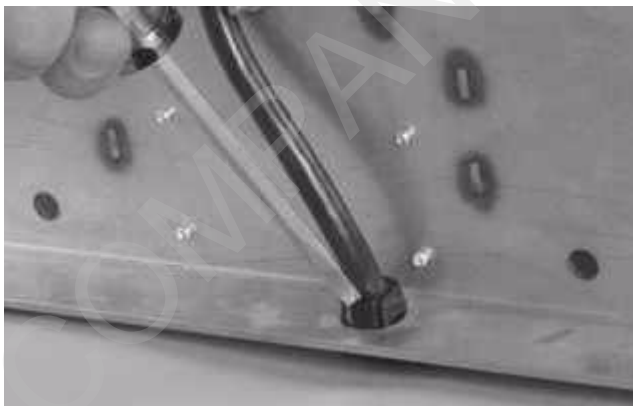

POWER CORD REPLACEMENT - BB-1 (CONTINUED)

Step 9: Install the new power cord through the openings in the frame and through the opening in the switch box. *See Section 7, Service Parts, Electrical Components-Power Cord for routing. Make sure to pull enough wire into the switch box for splicing.



Step 10: Reinstall the nuts, washers and cable clamps under the frame.



Step 11: Install the green ground wire to the back of the switch box using a 5/16" nut driver.



Step 12: Using the splice provided, crimp together the power cord's white wire with the motor cord's white wire.

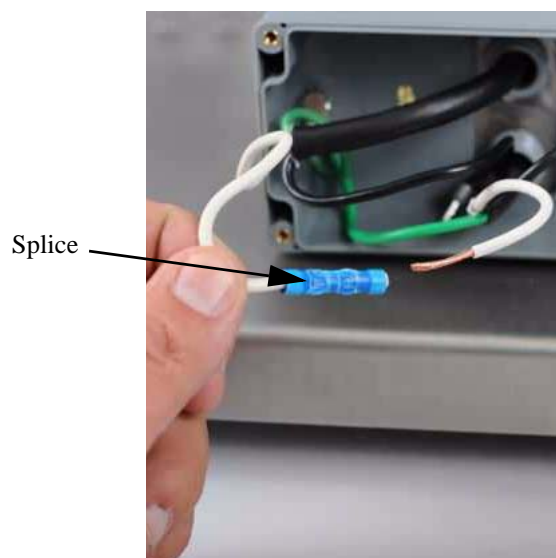



POWER CORD REPLACEMENT - BB-1 (CONTINUED)

Step 13: Install the black lead wires into switch terminals and tighten the retaining screws.

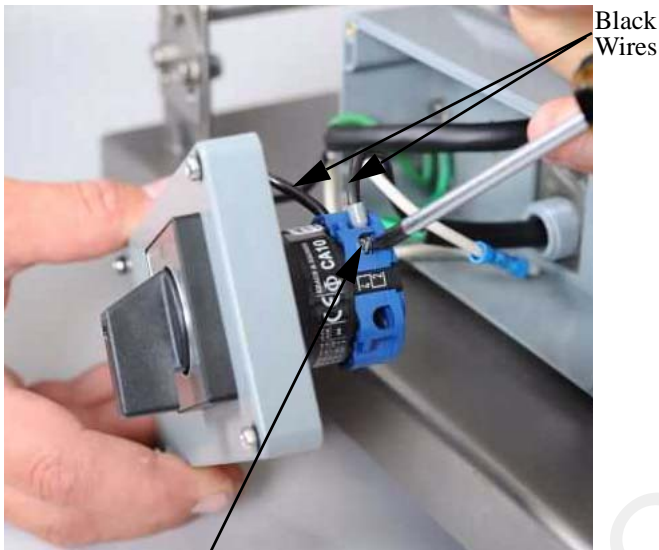

Step 14: Once all the wires are secure, install the switch plate onto the frame assembly and tighten the screws.

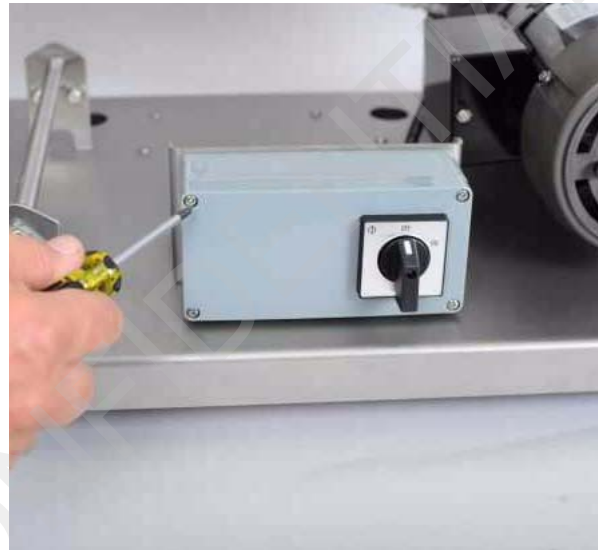

Step 15: Tighten the connector's top cap. **Make sure the outer jacket is completely through the connector.*

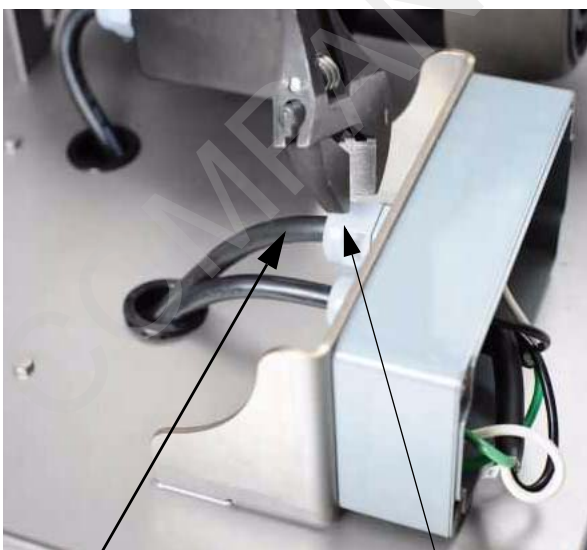



POWER CORD REPLACEMENT - BB-1 (CONTINUED)

Step 16: Using a pair of pliers, compress the strain relief bushing around the power cord. Insert the strain relief bushing through the opening in the frame.



Step 17: Reinstall the drive guard covers, knobs, and locking latch.





ON/OFF SWITCH REPLACEMENT - BB-2

Step 1: Disassemble frame assembly by removing:

- knobs
- locking latches (remove by aligning the tabs with the grooves)
- drive guard covers

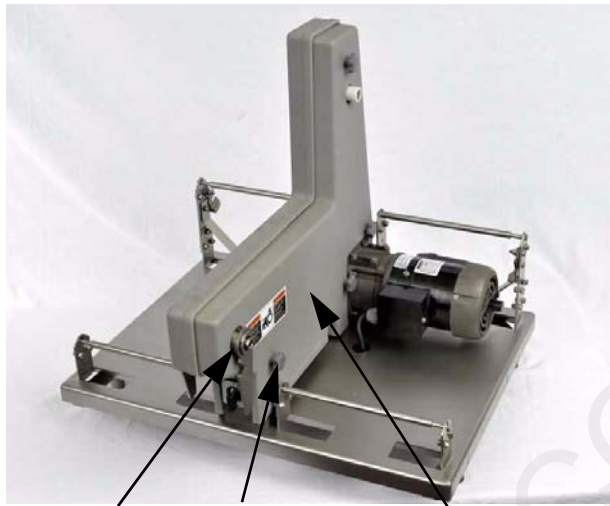

Locking Latch Knob Drive Guard Cover



ON/OFF SWITCH REPLACEMENT - BB-2 (CONTINUED)

 **WARNING**

Electrical shock may occur! Always disconnect unit from power supply prior to servicing.



All electrical repairs should be completed by a qualified electrician or approved service provider.

Step 2: Remove the 2 screws that attach the power switch assembly, by using a 5/16" nut driver.



Step 3: FOR 115V UNITS: Pull the power switch out of the power switch box and disconnect the two black wires from the back of the switch by loosening the retaining screws.



Step 4: Remove the power switch assembly from the switch body by releasing the red lever.

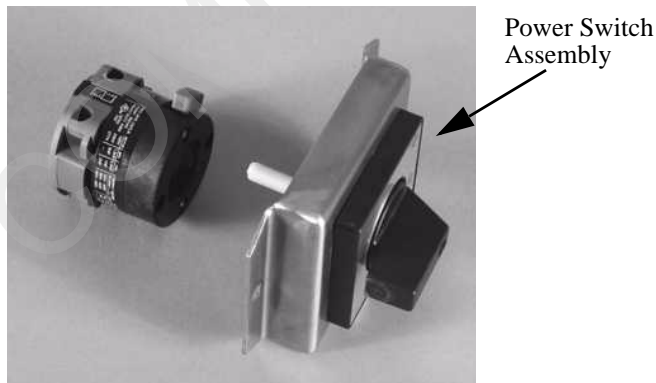



ON/OFF SWITCH REPLACEMENT - BB-2 (CONTINUED)

Step 5: Remove the switch lever from the switch plate by removing the locking ring on the rear of the switch plate.

Step 6: Install the new switch lever into the switch plate, aligning the tab on the switch knob with the cut out in the switch plate.

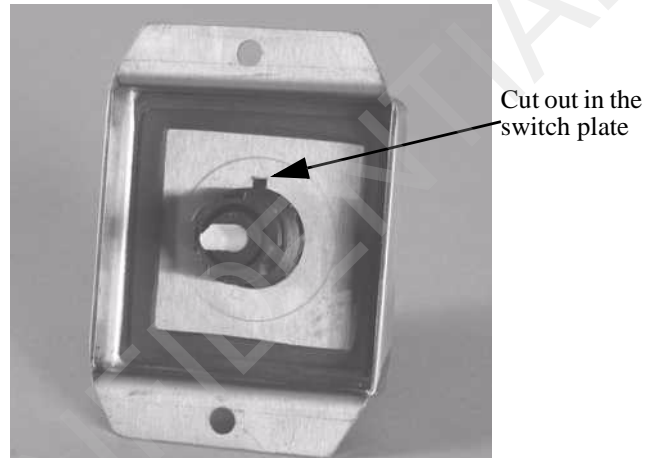
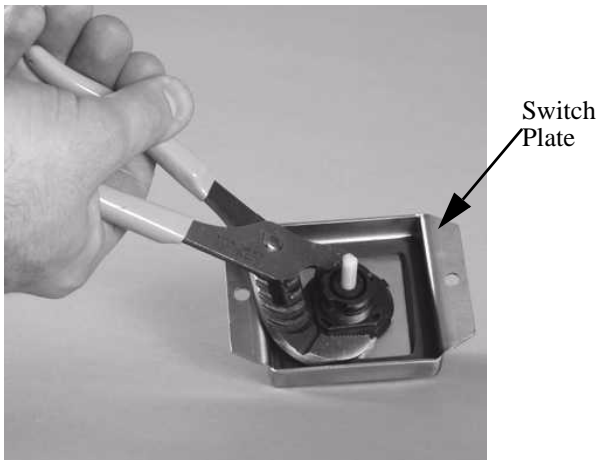

Step 7: Install the locking ring and tighten.

Step 8: Install the new switch body and secure it with the red lever.

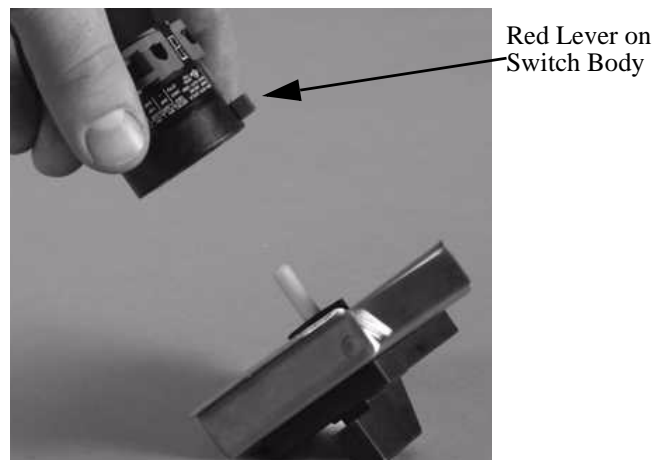
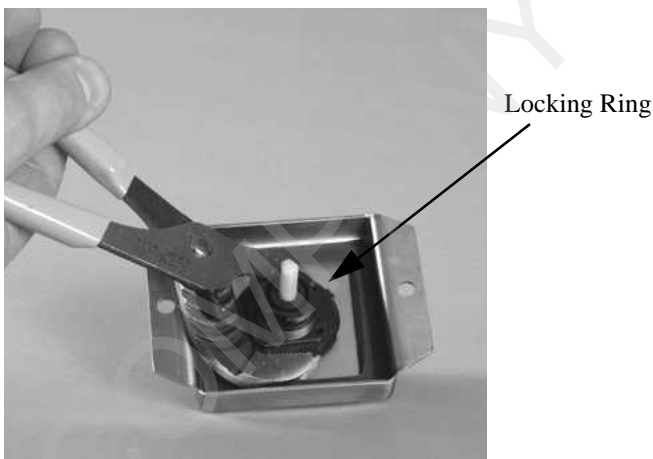

ON/OFF SWITCH REPLACEMENT - BB-2 (CONTINUED)

Step 9: FOR 115V UNITS: Install the two black wires and tighten the retaining screws.

Black Wires (115V)

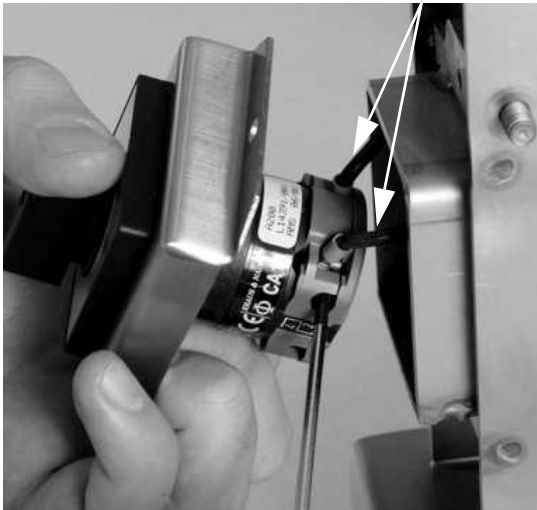

Step 10: Install the two screws attaching the power switch assembly to the frame.



Step 11: Reinstall the drive guard covers, knobs and locking latches.

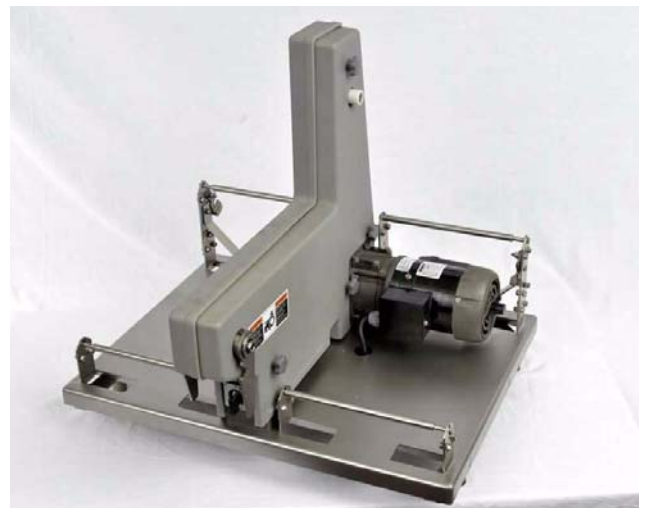



POWER CORD REPLACEMENT - BB-2

Step 1: Disassemble frame assembly by removing:

- knobs
- locking latches (remove by aligning the tabs with the grooves)
- drive guard covers

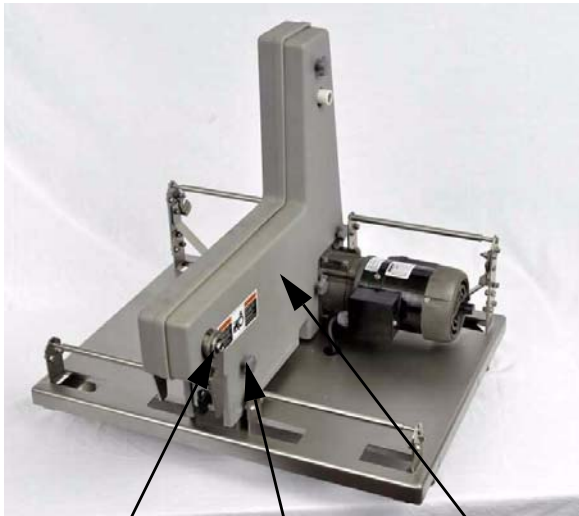

Locking Latch

Knob

Drive Guard Cover



POWER CORD REPLACEMENT - BB-2 (CONTINUED)

 **WARNING**

Electrical shock may occur! Always disconnect unit from power supply prior to servicing.



All electrical repairs should be completed by a qualified electrician or approved service provider.

Step 2: Remove the 2 screws that attach the power switch assembly, by using a 5/16" nut driver.



Step 3: FOR 115V UNITS: Pull the power switch out of the power switch box and disconnect the wires from the back of the switch by loosening the retaining screws.

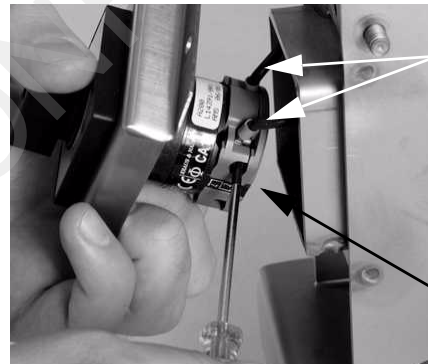

Black Wires (115V)

Retaining Screw



POWER CORD REPLACEMENT - BB-2 (CONTINUED)

Step 4: Remove the power cord ground wire screw from the inside of the power switch box by using a 5/16" nut driver.



Step 5: FOR 115V ONLY: The power cord neutral (white) wire is spliced to the motor cord wire (white). Remove the splice by cutting the white wires on either side of the splice. Strip the end of the motor cord's white wire.

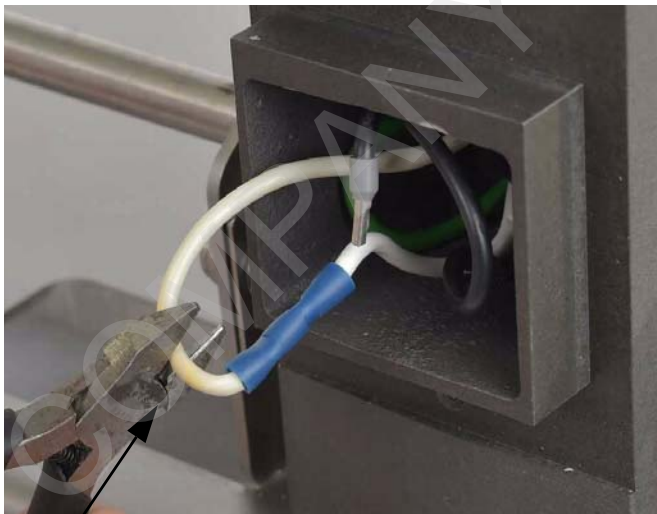

Splice 115V Only

POWER CORD REPLACEMENT - BB-2 (CONTINUED)

Step 6: Loosen the connector's top cap retaining the power cord. Pull the power cord out of the connector.



Connector's Top Cap

Step 7: Turn the frame on its back, so that the cords are visible. Remove the three nuts, washers and cable clamps that hold the power cord.

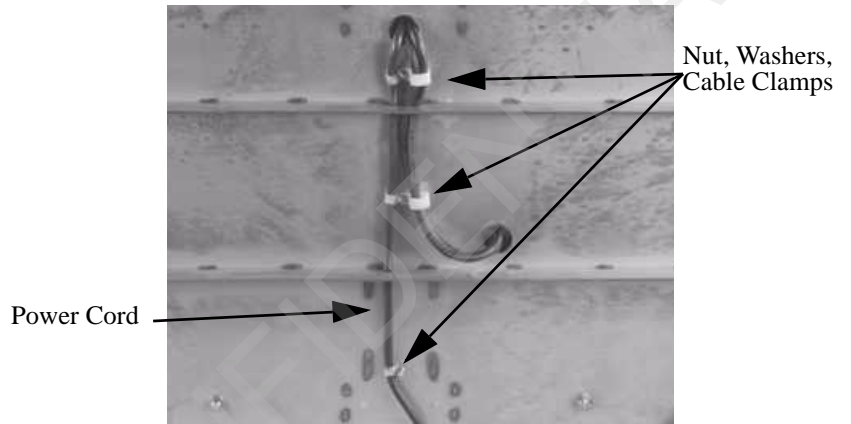

Underside Of Frame

Step 8: From the underside of the frame, use a screwdriver to push out the power cord strain relief bushing. If the strain relief bushing is not damaged, save for reuse on the new power cord.





POWER CORD REPLACEMENT - BB-2 (CONTINUED)

Step 9: Install the new power cord through the openings in the frame and through the opening in the switch box. *See Section 7, Service Parts, Electrical Components-Power Cord for routing. Make sure to pull enough wire into the switch box for splicing.



Step 10: Reinstall the nuts, washers and cable clamps under the frame.

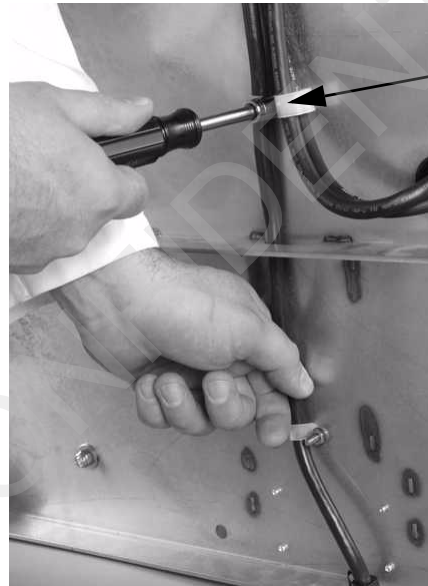

Cable Clamp

Step 11: Install the green ground wire to the back of the switch box using a 5/16" nut driver.



Step 12: FOR 115V UNITS ONLY: Using the splice provided, crimp together the power cord's white wire with the motor cord's white wire.

Splice 115V Only



POWER CORD REPLACEMENT - BB-2 (CONTINUED)

Step 13: FOR 115V UNITS: Install the black lead wires into switch terminals and tighten the retaining screws.

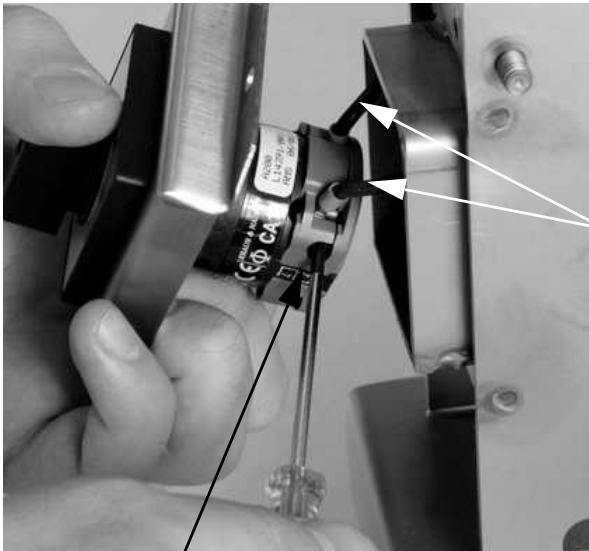

Black Wires (115V)

Retaining Screw

Step 14: Once all the wires are secure, install the switch plate onto the frame assembly and tighten the screws using a 5/16" nut driver.

Step 15: Tighten the connector's top cap. **Make sure the outer jacket is completely through the connector.*





POWER CORD REPLACEMENT - BB-2 (CONTINUED)

Step 16: Using a pair of pliers, compress the strain relief bushing around the power cord. Insert the strain relief bushing through the opening in the frame.



Step 17: Reinstall the drive guard covers, knobs and locking latches.

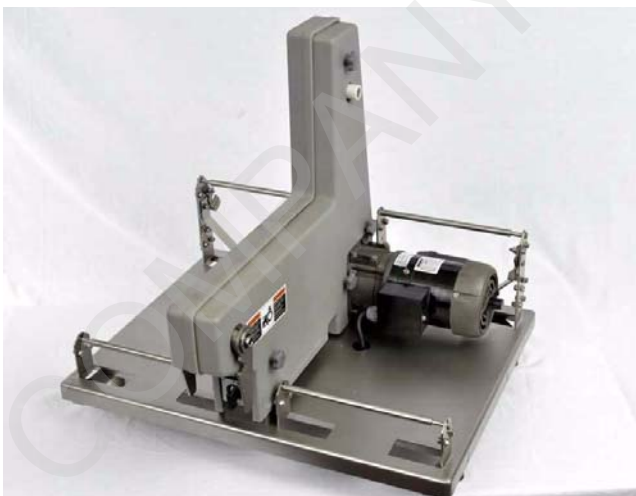

ON/OFF PUSH BUTTON SWITCH REPLACEMENT - BB-1F

Step 1: Disassemble frame assembly by removing:

- knobs
- locking latch (remove by aligning the tabs with the grooves)
- drive guard covers



Locking Latch Knobs Drive Guard Cover



Latch Alignment





ON/OFF PUSH BUTTON SWITCH REPLACEMENT - BB-1F (CONTINUED)



WARNING

Electrical shock may occur! Always disconnect unit from power supply prior to servicing.



All electrical repairs should be completed by a qualified electrician or approved service provider.

Step 2: Remove the screws that attach the power switch cover.



Step 3: Pull the power switch out of the power switch box and disconnect the wires from the back of the switch by loosening the retaining screws.

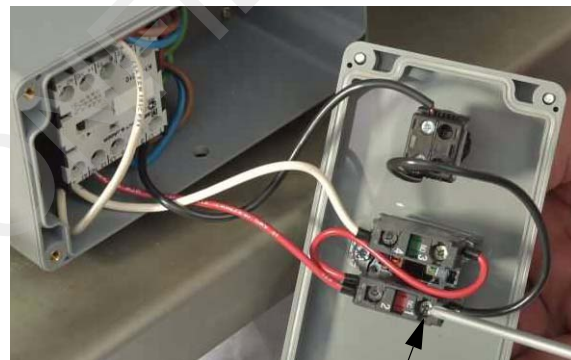

Retaining Screw

Step 4: Remove the power switch assembly from the switch body by loosening the switch body screw and releasing the lever.



Switch Body Screw



ON/OFF PUSH BUTTON SWITCH REPLACEMENT - BB-1F (CONTINUED)

Step 5: Install the new switch into the switch plate.



Step 6: Install the new switch body onto the switch and tighten the switch body screw securely.



Switch Body Screw



ON/OFF PUSH BUTTON SWITCH REPLACEMENT - BB-1F (CONTINUED)

Step 7: Install wires and tighten the retaining screws. *See electrical schematics in Section 7.



Step 8: Install the two screws attaching the power switch assembly to the frame.



Step 9: Reinstall the drive guard covers, knobs, and locking latch.



POWER CORD REPLACEMENT - BB-1F

Step 1: Disassemble frame assembly by removing:

- knobs
- locking latch (remove by aligning the tabs with the groove)
- drive guard covers



Locking Latch Knob Drive Guard Cover



Latch Alignment





POWER CORD REPLACEMENT - BB-1F (CONTINUED)

WARNING

Electrical shock may occur! Always disconnect unit from power supply prior to servicing.



All electrical repairs should be completed by a qualified electrician or approved service provider.

Step 2: Remove the 4 screws that attach the enclosure cover and remove cover.



Step 3: Loosen the retaining screws on the contact block to remove the power cord wires from the dropout relay.

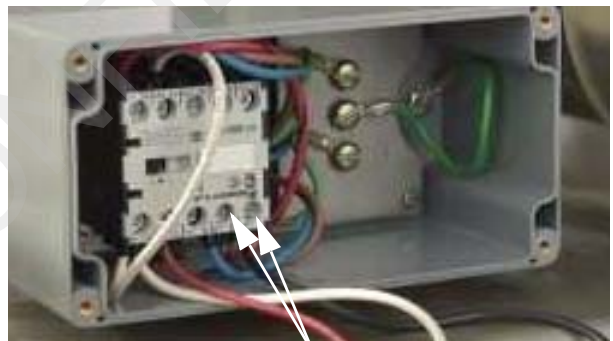

Retaining Screws

Step 4: Remove the power switch assembly from the panel.

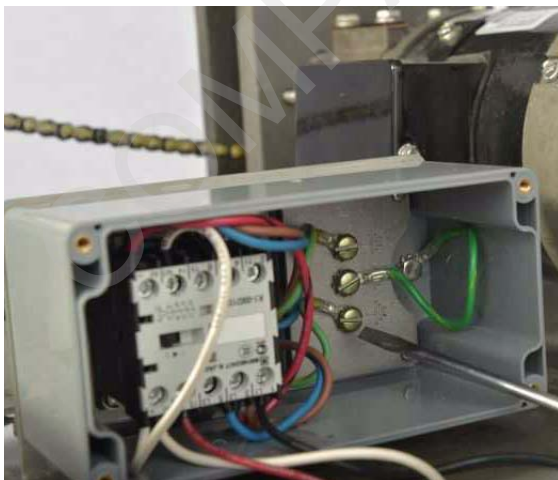

POWER CORD REPLACEMENT - BB-1F (CONTINUED)

Step 5: Loosen the connector's top cap retaining the power cord. Pull the power cord out of the connector.



Power Cord Connector's Top Cap

Step 6: Turn the frame on its back, so that the cords are visible. Remove the three nuts, washers and cable clamps that hold the power cord.



Power Cord

Underside Of Frame

Nut,
Washers,
Cable
Clamps

Step 7: From the underside of the frame, use a screwdriver to push out the power cord strain relief bushing. If the strain relief bushing is not damaged, save for reuse on the new power cord.





POWER CORD REPLACEMENT - BB-1F (CONTINUED)

Step 8: Install the new power cord through the openings in the frame and through the opening in the switch box.**See Section 7, Service Parts, Electrical Components-Power Cord for routing. Make sure to pull enough wire into the switch box for splicing.*



Step 9: Reinstall the nuts, washers and cable clamps under the frame.

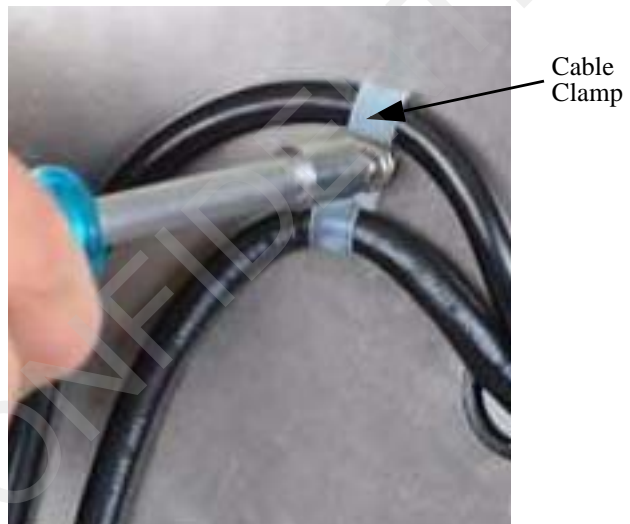

Step 10: Install the green ground wire to the panel.



POWER CORD REPLACEMENT - BB-1F (CONTINUED)

Step 11: Install the black lead wires into switch terminals and tighten the retaining screws.

Step 12: Once all the wires are secure, install the switch plate onto the frame assembly and tighten the screws.

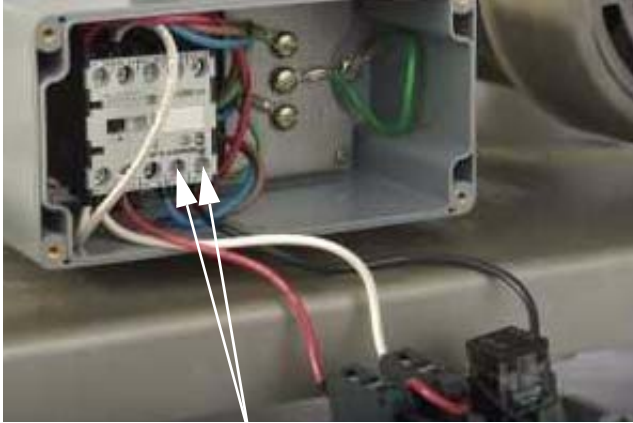

Retaining Screws



Step 13: Tighten the power cord connector's top cap. **Make sure the outer jacket is completely through the connector.*



Connector's Top Cap

Power Cord



POWER CORD REPLACEMENT - BB-1F (CONTINUED)

Step 14: Using a pair of pliers, compress the strain relief bushing around the power cord. Insert the strain relief bushing through the opening in the frame.



Step 15: Reinstall the drive guard covers, knobs, and locking latch.





Section 5D

Maintenance Preventive

CONTENTS OF THIS SECTION

Safety Recommendations and Warnings	5D-1
Preventive Maintenance Checks	5D-2
Daily Preventive Maintenance Chart	5D-2
Monthly Preventive Maintenance Chart	5D-2
Six Month Preventive Maintenance Chart	5D-2

SAFETY RECOMMENDATIONS AND WARNINGS



WARNING



All maintenance procedures should be performed by qualified personnel.

The information provided in these operating instructions is important to your health, comfort and safety. For safe and proper operation, read this entire manual before using this equipment.

Please read and save these instructions. Read carefully before attempting to assemble, install, operate or maintain this product. Protect yourself, others and equipment by observing all safety information. Failure to comply with instructions could result in personal injury and/or damage to the equipment. Any use in applications other than those for which the equipment was designed and built may result in equipment damage and/or serious injuries.

Retain this manual for future reference. Be thoroughly familiar with the controls and proper use of this equipment.

The manufacturer assumes no liability for any unauthorized changes in operating procedures or for unauthorized changes or modifications made to the design of the machine or any factory-installed safety equipment, whether these changes are made by the owner of this equipment, by his employees, or by service providers not previously approved by Bettcher Industries, Inc.



PREVENTIVE MAINTENANCE CHECKS

Regular maintenance of the machine will keep it running properly and will help extend the operating life. The checks that are recommended and the time intervals of each check are provided in the following table.

Daily Preventive Maintenance Chart

Item to Check	Procedure	Action
Machine inspection and cleaning	Check for signs of equipment damage and refer to cleaning instructions in Section 6.	Repair or replace damaged components. See Section 7 for parts listings.
Knobs on guards and conveyor assemblies	Check for loose or missing knobs.	Retighten or replace knobs as required.
Vibrator springs and paddles	Check components for proper installation and proper position.	Re-install or reposition components.
Wirebelts	Check conveyor wire belts for signs of bending, breakage and excessive wear.	Replace wirebelt.

Monthly Preventive Maintenance Chart

Item to Check	Procedure	Action
Power Cord	Check that the power cord has no visible nicks or cuts in the black outer jacket. Check that the plug end has no damaged or missing prongs.	Refer to the power cord replacement instructions in the frame section of this manual.

Six Month Preventive Maintenance Chart

Item to Check	Procedure	Action
Regrease breader drive shaft and bearings.	Pump grease into fill ports.	Refer to the breader drive shaft/bearing replacement instructions in the frame assembly section of this manual.
Lubrication	Apply food grade spray lubrication to chain.	Refer to Section 7 Service Parts for Lubrication Kit.
Drive Chain Tension	Check that the drive chain slack is 3/4".	Refer to the drive chain replacement instructions in the frame section of this manual.

Section 5E

Maintenance Trouble Shooting

CONTENTS OF THIS SECTION

Safety Recommendations and Warnings	5E-1
Trouble Shooting/Fault Detection and Correction	5E-2
Problem 1: Breeding is coming off of the end of the conveyor.	5E-2
Problem 2: Batter/Breeding coverage is not satisfactory.	5E-2
Problem 3: Erratic Batter/Breeder Conveyor Product Feed.	5E-2
Problem 4: Batter Conveyor is not moving.	5E-3
Problem 5: Breeder Conveyor is not moving.	5E-3
Problem 6: Motor is making noise (Scraping sound)	5E-4
Problem 7: Motor is running and machine does not operate	5E-4
Problem 8: Motor is not running.	5E-5

SAFETY RECOMMENDATIONS AND WARNINGS



All maintenance procedures should be performed by qualified personnel.

The information provided in these operating instructions is important to your health, comfort and safety. For safe and proper operation, read this entire manual before using this equipment.

Please read and save these instructions. Read carefully before attempting to assemble, install, operate or maintain this product. Protect yourself, others and equipment by observing all safety information. Failure to comply with instructions could result in personal injury and/or damage to the equipment. Any use in applications other than those for which the equipment was designed and built may result in equipment damage and/or serious injuries.

Retain this manual for future reference. Be thoroughly familiar with the controls and proper use of this equipment.

The manufacturer assumes no liability for any unauthorized changes in operating procedures or for unauthorized changes or modifications made to the design of the machine or any factory-installed safety equipment, whether these changes are made by the owner of this equipment, by his employees, or by service providers not previously approved by Bettcher Industries, Inc.

Use only replacement parts manufactured by Bettcher Industries, Inc. Use of substitute parts will void the warranty and may cause injury to operators and damage the equipment.



TROUBLE SHOOTING/FAULT DETECTION AND CORRECTION

Problem 1: Breeding is coming off of the end of the conveyor.

Possible Causes	Possible Solutions
Breeding is too wet.	Change breeding material.
Breeder unit is over filled.	Unload breeding material.
Vibrator Springs Missing	Check for Vibrator Spring Placement

Problem 2: Batter/Breeding coverage is not satisfactory.

Possible Causes	Possible Solutions
Batter tank is not properly filled.	Add batter to the batter tank.
Breeder tank is not properly filled.	Add breeding to the breeder conveyor.

Problem 3: Erratic Batter/Breeder Conveyor Product Feed.

Possible Causes	Possible Solutions
Batter conveyor assembly is not properly engaged.	Realign batter conveyor assembly. See installation instructions in Section 3.
Breeder Conveyor belting may need repair.	Refer to the wirebelt replacement instructions in the breeder tank section of this manual.
Batter drive shaft is not rotating.	Refer to the batter drive shaft/bearing replacement instructions in the frame assembly section of this manual.

**TROUBLE SHOOTING/FAULT DETECTION AND CORRECTION
(CONTINUED)**

Problem 4: Batter Conveyor is not moving.

Possible Causes	Possible Solutions
Batter Conveyor assembly is not properly engaged.	Realign batter conveyor assembly. See installation instructions in Section 3.
Batter Conveyor wirebelt may need repair.	Refer to the batter conveyor wirebelt replacement instructions in the batter tank section of this manual.
Batter drive shaft is not rotating.	Refer to the batter drive shaft/bearing replacement instructions in the frame assembly section of this manual.

Problem 5: Brearder Conveyor is not moving.

Possible Causes	Possible Solutions
Brearder assembly is not properly engaged.	Re-align brearder conveyor assembly. See the installation instructions in Section 3.
Brearder conveyor wirebelting may need repair.	Refer to the wirebelt replacement instructions in the brearder tank section of this manual.
Brearder drive shaft is not rotating.	Refer to brearder drive shaft/bearing replacement instructions in the frame assembly section of this manual.
Brearder coupler is worn.	Replace the coupler. Refer to Section 7, Brearder Drive service parts for the coupler part number.



TROUBLE SHOOTING/FAULT DETECTION AND CORRECTION (CONTINUED)

Problem 6: Motor is making noise (Scraping sound)

Possible Causes	Possible Solutions
Obstructions in front of motor fan area.	Remove all obstructions from in front of fan area.
Damaged Air Shield or fan	Replace motor. All electrical repairs should be made by a qualified electrician or service provider.

Problem 7: Motor is running and machine does not operate

Possible Causes	Possible Solutions
Drive chain is broken.	Replace chain. Refer to the drive chain replacement instructions in the frame assembly section of this manual.
Drive chain tension is not correct.	Chain deflection should be 3/4".
Drive chain links locked up or seized.	<p>Remove Drive Chain (Refer to Section 5C Drive Chain Replacement).</p> <ul style="list-style-type: none"> • Soak chain in degreaser/solvent. • Wipe off degreaser/solvent. • Lubricate using a food grade lubricant. <p>(Refer to Section 7 Service Parts for Lubrication Kit)</p>

**TROUBLE SHOOTING/FAULT DETECTION AND CORRECTION
(CONTINUED)**

Problem 8: Motor is not running.

Possible Causes	Possible Solutions
Power cord is not plugged in.	Connect power cord to wall outlet.
Power switch is not turned to "ON".	Turn power switch to "ON".
The circuit breaker for the wall outlet has been activated.	Have an electrician reset the tripped circuit breaker, then check the wall outlet and repair as needed.
Is the overload on the motor activated? (Canadian Version Only)	Press the overload button on the motor unit. This only applies to Canadian units.
Obstructions in front of motor fan area.	Remove all obstructions from in front of fan area. See cleaning instructions in Section 6 of this manual.



THIS PAGE INTENTIONALLY LEFT BLANK

COMPANY CONFIDENTIAL

Section 6

Cleaning

CONTENTS OF THIS SECTION

Cleaning Instructions	2
Batter Assembly - Daily	2
Breeder Assembly - Daily	4
Frame Assembly - Every 6 Months	10

 **WARNING**

To avoid personal injury, always disconnect the power cord before performing any adjustments, disassembly / assembly, trouble shooting or cleaning.



NOTICE

The recommended cleaning solution for the Optimax® Batter-Breeder Machine is eXtra® Heavy Duty Cleaner.



eXtra® Heavy Duty Cleaner, (PN: 184332), is a concentrated cleaner and degreaser for food processing equipment. Contact Bettcher Industries, Inc. for details.

NOTICE

Do not machine wash drive guard covers or batter tanks. Excessive heat generated by machine washing can damage parts.

Do not submerge frame and motor assembly as damage to motor could result. Clean with damp cloth or sponge only.

NOTICE

Do not submerge or directly spray frame and motor assembly. Damage could occur and may void the warranty. Clean with damp cloth or sponge only. Dry after cleaning.

Do not wash drive components including sprockets and drive chain.

Do not machine wash.

CLEANING INSTRUCTIONS**Batter Assembly - Daily**

Step 1: Turn the power switch **OFF**. Unplug power cord.

Step 2: Lift the batter conveyor assembly enough to pull the conveyor drive shaft out of the guide sleeve.

Step 3: Remove the batter conveyor tank assembly.



Conveyor Drive Shaft

Guide Sleeve



Step 4: Pour batter out of the batter tank.



CLEANING INSTRUCTIONS (CONTINUED)

Batter Assembly - Daily (Continued)

Step 5: Remove the batter conveyor assembly from the batter tank. Machine or hand wash conveyor assembly using Bettcher Industries, Inc. eXtra® Heavy Duty Cleaner. O-rings can be moved towards the center of the batter wheel if needed for cleaning.

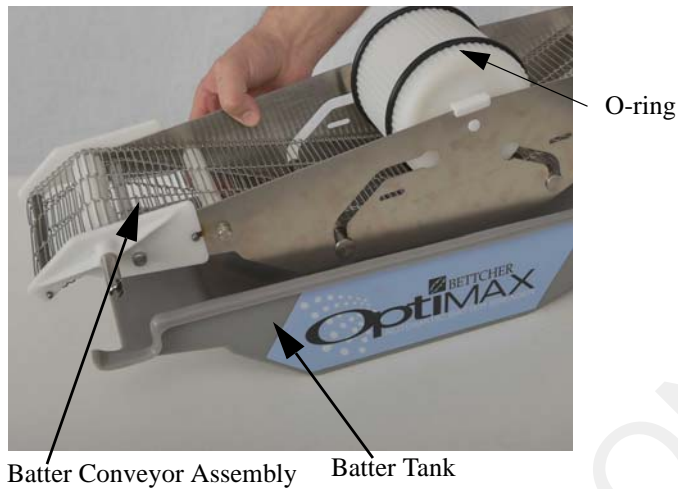

Step 6: Hand wash the batter tank and turn upside down to air dry.



Step 7: After the components are dry, place the batter conveyor assembly into the batter tank.





CLEANING INSTRUCTIONS (CONTINUED)

Breader Assembly - Daily

Step 1: Disassemble breader conveyor by removing:

Discharge Tray

- Pull the top of the discharge tray away from the breader assembly releasing the tray from the breader holes.

Discharge Tray

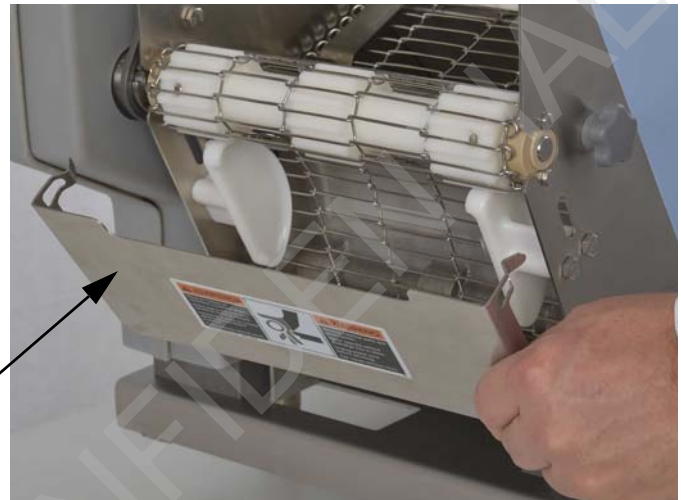

Pan Bracket

- Remove the pan bracket from the breader conveyor side rail.

Pan Bracket

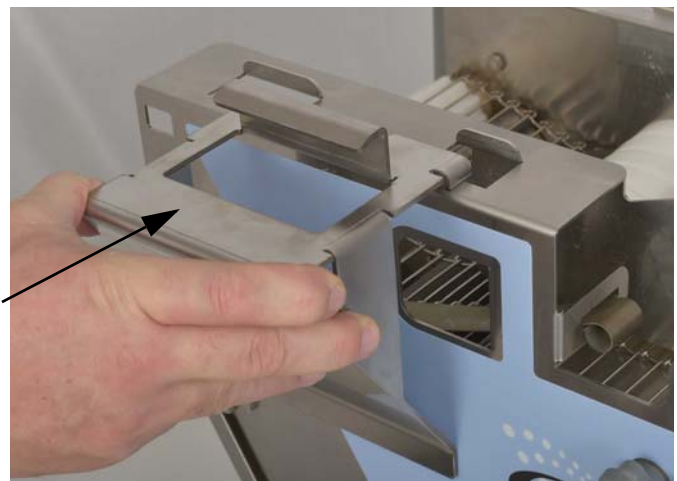

CLEANING INSTRUCTIONS (CONTINUED)

Breeder Assembly - Daily (Continued)

Step 2: Place discharge pan in front of breeder unit



Step 3: Disengage locking latch.



Step 4: Support breeder at the front with left hand on the sprocket and right hand at the rear. (Place thumb through the handle with fingers supporting bottom pan.)

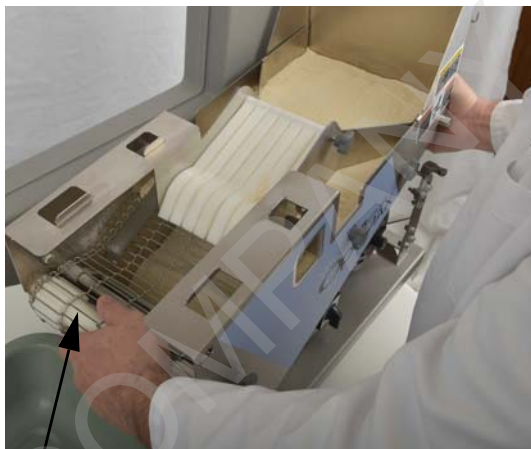

Sprocket





CLEANING INSTRUCTIONS (CONTINUED)

Breader Assembly - Daily (Continued)

Step 5: Slide the breader into the discharge pan.

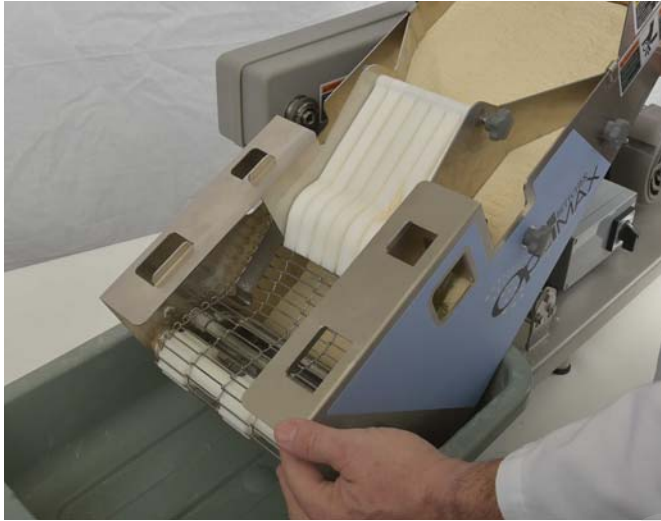

Step 6: Empty breading into discharge pan.



CLEANING INSTRUCTIONS (CONTINUED)

Breader Assembly - Daily (Continued)

Step 7: Pull bottom pan away from breader and remove.

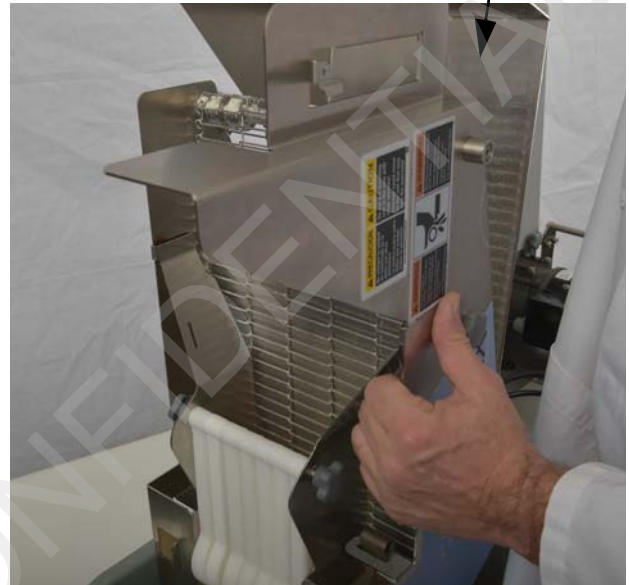

Step 8: Remove discharge tray and discharge extra breading.

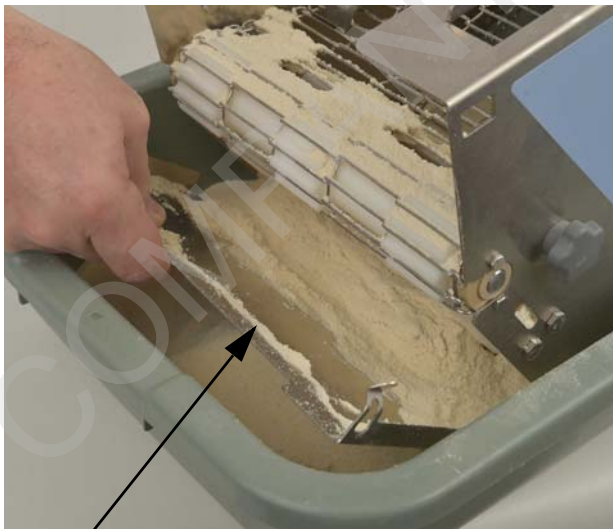

Discharge Tray





CLEANING INSTRUCTIONS (CONTINUED)

Breader Assembly - Daily (Continued)

NOTICE

The recommended cleaning solution for the Optimax® Batter-Breader Machine is eXtra® Heavy Duty Cleaner.



eXtra® Heavy Duty Cleaner, (PN: 184332), is a concentrated cleaner and degreaser for food processing equipment. Contact Bettcher Industries, Inc. for details at 1 800 321-8763.

Step 9: Machine or hand wash the breader conveyor assembly and bottom pan.



Step 10: Machine or hand wash discharge tray and pan bracket.



CLEANING INSTRUCTIONS (CONTINUED)

Breader Assembly - Daily (Continued)

Step:11 After cleaning, reassemble unit. Refer to Section 3, *Installation Instructions*.





CLEANING INSTRUCTIONS (CONTINUED)

Frame Assembly - Every 6 Months

 **WARNING**

To avoid personal injury, always disconnect the power cord before performing any adjustments, disassembly / assembly, trouble shooting or cleaning.



NOTICE

Do not submerge or directly spray frame and motor assembly. Damage could occur and may void the warranty. Clean with damp cloth or sponge only. Dry after cleaning.

Do not wash drive components including sprockets and drive chain.

Do not machine wash.

CLEANING INSTRUCTIONS (CONTINUED)

Frame Assembly - Every 6 Months (Continued)

Step 1: Disassemble the frame assembly by removing:

- locking latch (remove by aligning the tabs with the grooves)
- knobs
- drive guard covers

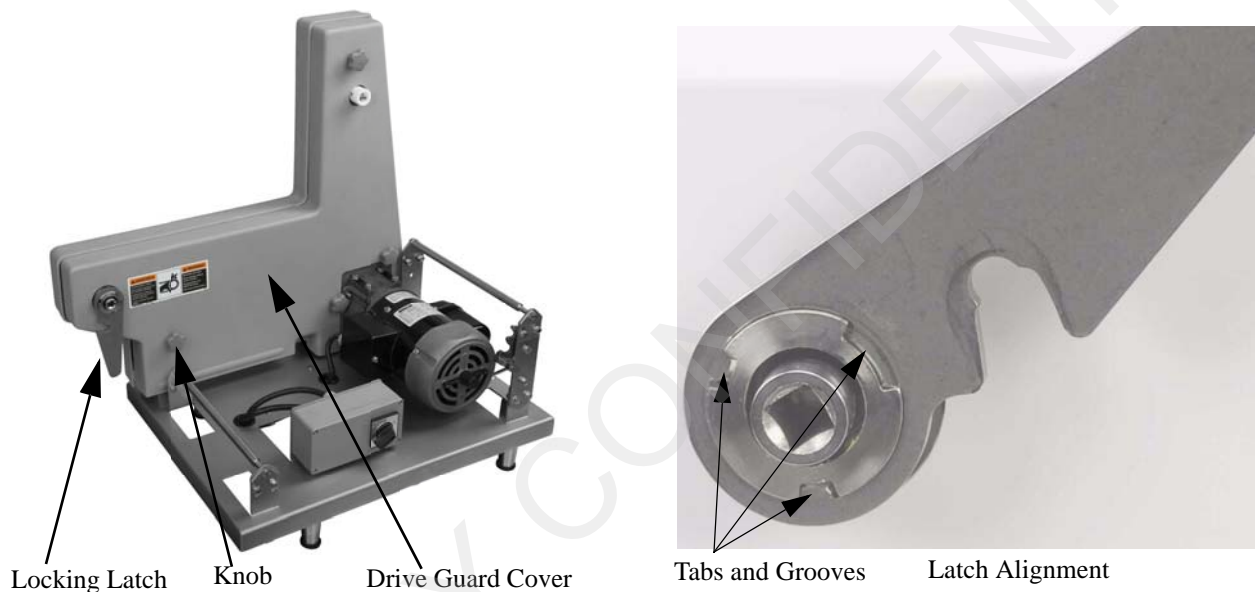

Step 2: Clean both drive guard covers by wiping them with a damp cloth or sponge.





CLEANING INSTRUCTIONS (CONTINUED)

Frame Assembly - Every 6 Months (Continued)

WARNING

To avoid personal injury, always disconnect the power cord before performing any adjustments, disassembly / assembly, trouble shooting or cleaning.



NOTICE

Do not wash drive components including sprockets and drive chain

Step 3: Brush off any loose breading material. Use a damp soapy sponge or towel to clean the frame, motor and motor vents. Wipe dry.

IMPORTANT: *Brush and remove any debris from the drive chain. Visibly check the chain for proper lubrication. If the chain appears dry, lubricate with food grade lubricant (Refer to Service Section 7 for Lubrication Kit).*



CLEANING INSTRUCTIONS (CONTINUED)

Frame Assembly - Every 6 Months (Continued)

Step 4: Reinstall the drive guard covers, knobs, and locking latch to the frame.



Step 5: After cleaning, reassemble unit. *Refer to Section 3, Installation Instructions.*

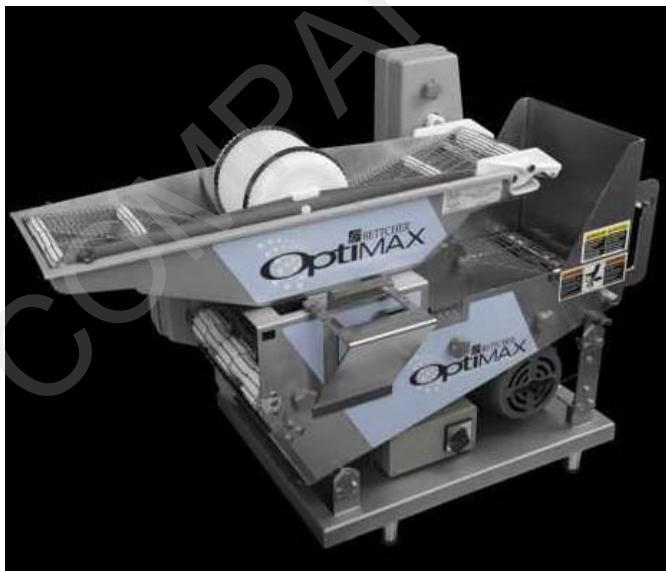



THIS PAGE INTENTIONALLY LEFT BLANK

COMPANY CONFIDENTIAL



Section 7

Service Parts

CONTENTS OF THIS SECTION

How to order Parts	7-2
Drive Guard and Specification Plate	7-4
Frame Assembly	7-6
Drive Assembly	7-8
Drive Assembly - Brearder Drive	7-10
Drive Assembly- Batter Drive	7-12
Drive Assembly - Drive Motor and Chain	7-14
Brearder Conveyor - External Parts	7-16
Brearder Conveyor - Internal Parts	7-18
Batter Conveyor Components	7-20
Electrical Components - Power Cord - BB-1	7-22
Electrical Components - Switch / Motor Cord - BB-1	7-24
Electrical Components - Capacitor and Switch - BB-1	7-26
Electrical Components - Power Cord - BB-2	7-28
Electrical Components - Switch / Motor Cord - BB-2	7-30
Electrical Components - Capacitor and Switch - BB-2	7-32
Electrical Components - Power Cord 230V - BB-1F	7-34
Electrical Components - Motor Cord 230V - BB1-F	7-36
Electrical Components - Capacitor and Switch 230V - BB1-F	7-38
Safety Labels	7-40
Optional Equipment Available	7-42
Electrical Schematics	7-43
115V/1PH/60Hz Internal Capacitor	7-43
115V/1PH/60HZ Internal Capacitor (Canadian)	7-44
230V/1PH/50HZ Internal Capacitor	7-45



HOW TO ORDER PARTS

Contact our service department by phone, fax or mail.

Bettcher Industries, Inc.

Attn: Service Department

P.O. Box 336

Vermilion, OH 44089

Phone: (440) 965-4422

Phone: (800) 321-8763

Fax: (440) 328-4535

When ordering parts, please include the following information with your request.

- **Part Number** from parts list.
- **Complete description** of the part as given in the parts list.
- **Model number and serial number** of your machine.

HOW TO ORDER PARTS (CONTINUED)

The model number and serial number are stamped on the red model number plate, located at the rear of the machine frame, directly above where the power cord enters the machine.

Serial Number Identification

This label contains the following information:

- Model
- Model Type
- Serial Number
- Factory Number
- Operating: Voltage/Phase/Frequency/Current

○ BETTCHER INDUSTRIES, INC. ○			
Birmingham, Ohio 44816 U.S.A.			
COMMERCIAL BATTER/BREADER MACHINE			
Model OPTIMAX-		[]	
CONFORMS TO:	S/N	[]	
ANSI/UL STD 743	Factory No.	[]	
	VOLTS	PHASE	Hz
	[]	[]	[]
		AMPS	[]
			[]

○ BETTCHER INDUSTRIES, INC. ○			
Birmingham, Ohio 44816 U.S.A.			
COMMERCIAL BATTER/BREADER MACHINE			
Model OPTIMAX-		[]	
CONFORMS TO:	S/N	[]	
CAN/CSA STD C22.2 NO. 195-M1987	Factory No.	[]	
	VOLTS	PHASE	Hz
	[]	[]	[]
		AMPS	[]
			[]

○ BETTCHER INDUSTRIES, INC. ○			
Birmingham, Ohio 44816 U.S.A.			
BATTER-BREADER			
Model OPTIMAX-		[]	
CE	S/N	[]	
	Factory No.	[]	
	VOLTS	PHASE	Hz
	[]	[]	[]
		AMPS	[]
			[]



DRIVE GUARD AND SPECIFICATION PLATE

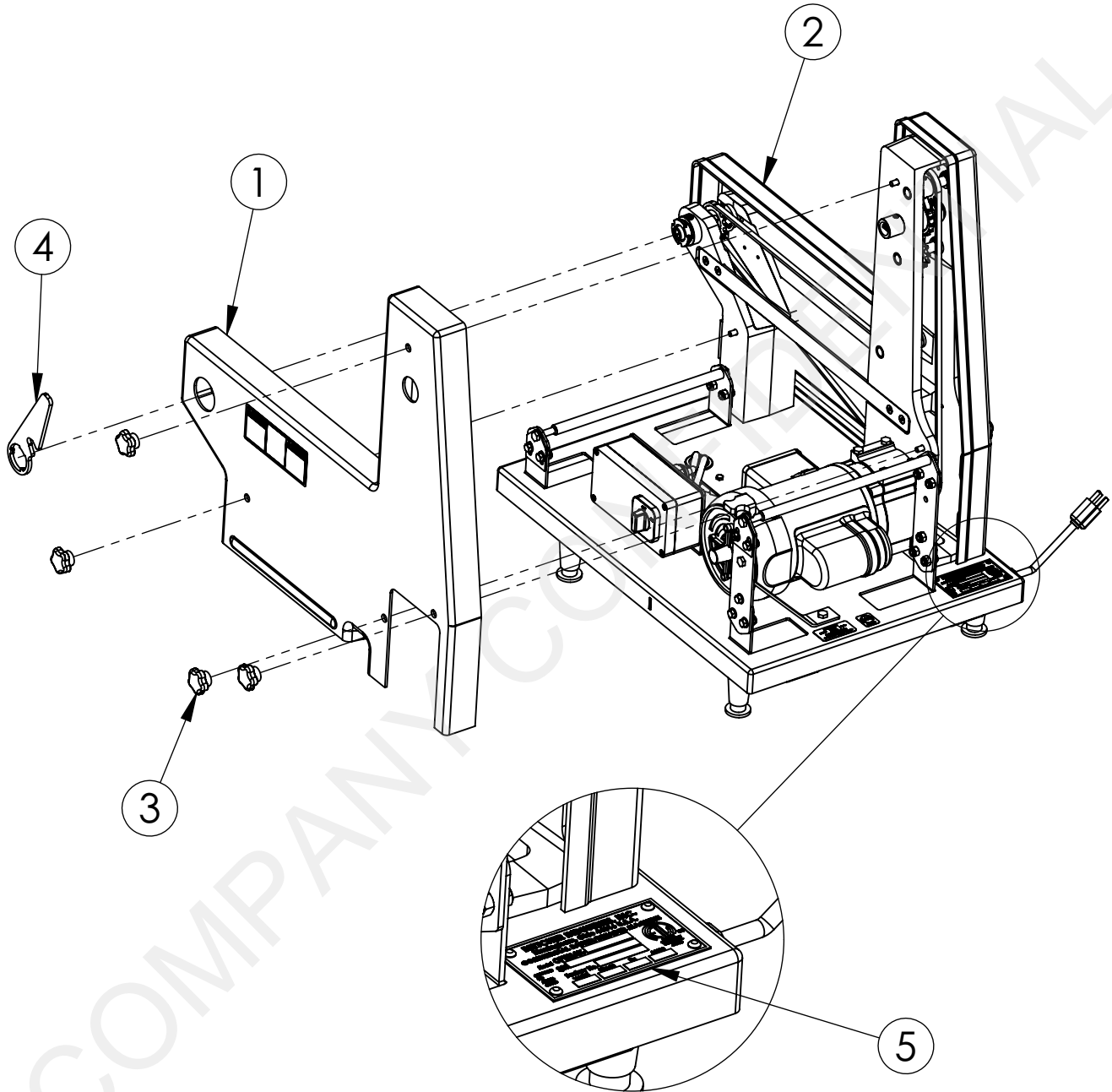



DRIVE GUARD AND SPECIFICATION PLATE (CONTINUED)

Item	Description	Part Number	Quantity
1	Drive Guard, RH, English/Spanish	103622	1
--	Drive Guard, RH English/French	103641	1
2	Drive Guard, LH, English/Spanish	103623	1
--	Drive Guard, LH English/French	103640	1
3	Knob	501475	9
4	Locking Latch	501000	1
5	Specification Plate	502033	1
--	Specification Plate (CANADA)	502032	1
--	Specification Plate	501824	1



FRAME ASSEMBLY

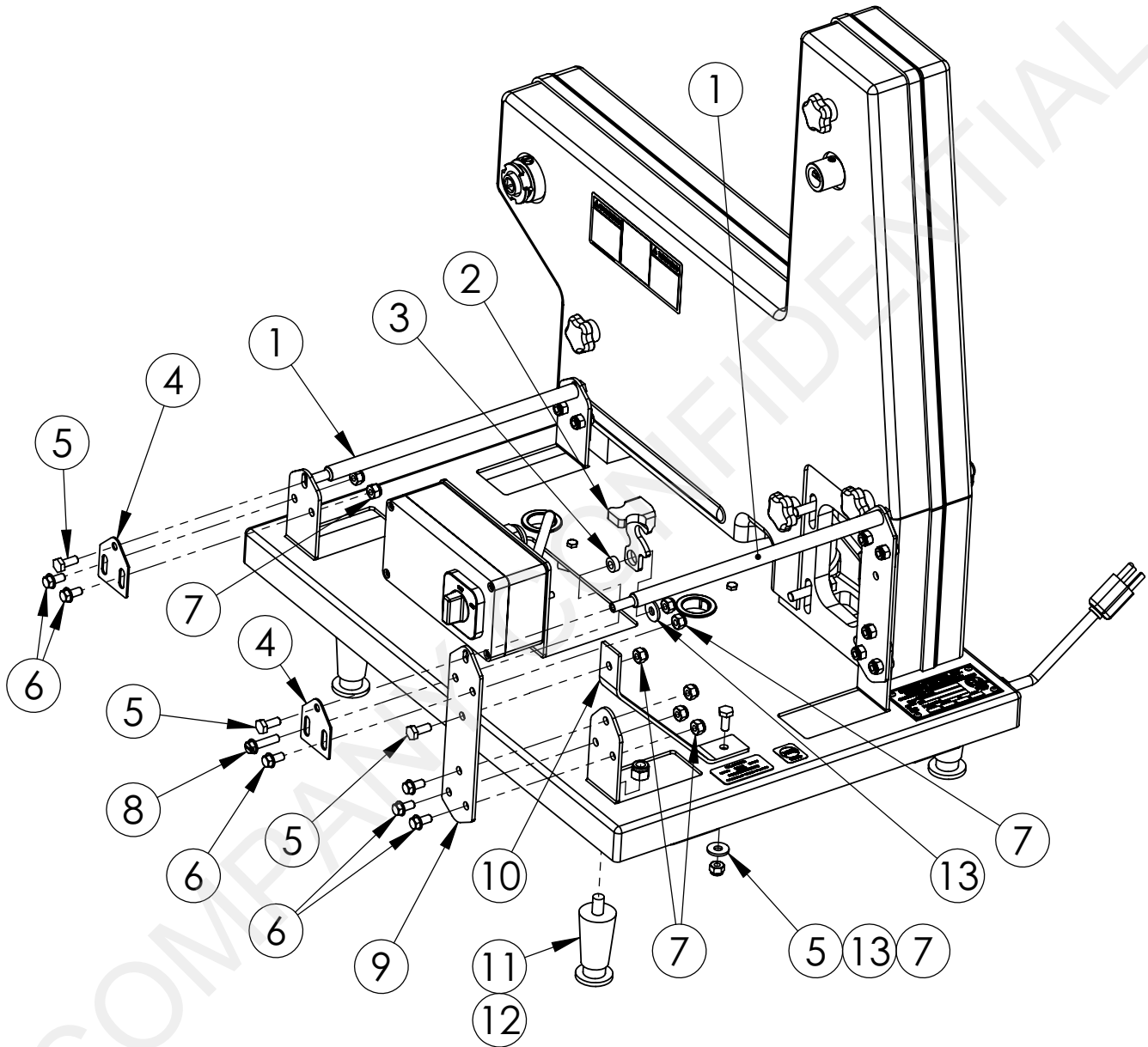



FRAME ASSEMBLY (CONTINUED)

ITEM	Description	Part Number	Quantity
1	Breader Support Shaft	102675	2
2	Spacer Lock	102673	1
3	Spacer Lock Bushing	102674	1
4	Adjustable Retaining Plate	500377	4
5	Hex Head Screw 1/4-20 x 5/8"	120587	6
6	Hex Washer Head Screw 1/4-20 x 1/2"	123234	13
7	ESNA Nut 1/4-20	120304	16
8	Hex Washer Head Screw 1/4-20 x 1"	123263	1
9	Rear Support	102678	2
10	Support Brace	500437	1
11	Leg Assembly 2-1/2"	502050	4
12	ESNA Nut 3/8-16	125307	4
13	Washer 1/4" Special	120261	2



DRIVE ASSEMBLY

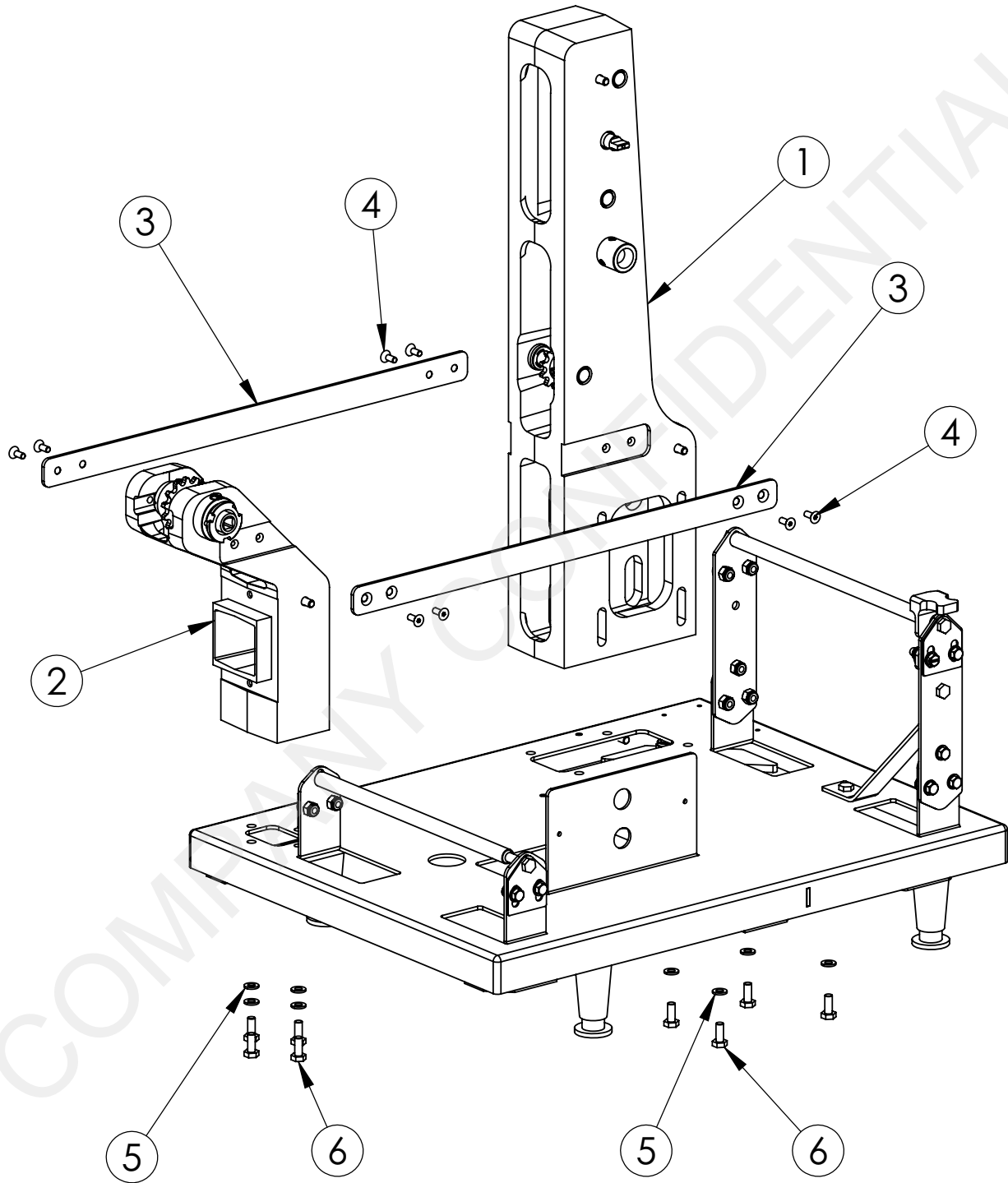



DRIVE ASSEMBLY (CONTINUED)

ITEM	Description	Part Number	Quantity
1	Batter Drive Assembly	102129	1
2	Breader Drive Assembly	102119	1
3	Tower Brace	102022	2
4	Flat Head Screw #10-24 x 1/2"	123280	8
5	Lock Washer 1/4"	120220	8
6	Hex Head screw 1/4-20 x 5/8"	120587	8

DRIVE ASSEMBLY-BREADER DRIVE (CONTINUED)

Item	Description	Part Number	Quantity
1	Bearing Housing, Front	102239	1
2	Needle Bearing	501339	2
3	Locking Housing	501340	1
4	Drive Shaft Coupling	501345	1
5	Screw	501346	1
6	Woodruff Key	122605	1
7	Drive Shaft	501369	1
8	Cap Screw, #10-24 x 2/3"	122794	2
9	Thrust Washer (Silver)	501368	4
10	Thrust Bearing (Gold)	501367	2
11	Retaining Ring	122047	2
12	Spacer Ring	501716	1
13	Split Collar, Threaded	501717	1
14	Split Collar	501718	1
15	Cap Screw, #6-32 x 5/8"	501374	2
16	Machined Sprocket	501365	1
17	Sprocket Set Screw 1/4-20 x 1/2"	123108	2



DRIVE ASSEMBLY- BATTER DRIVE

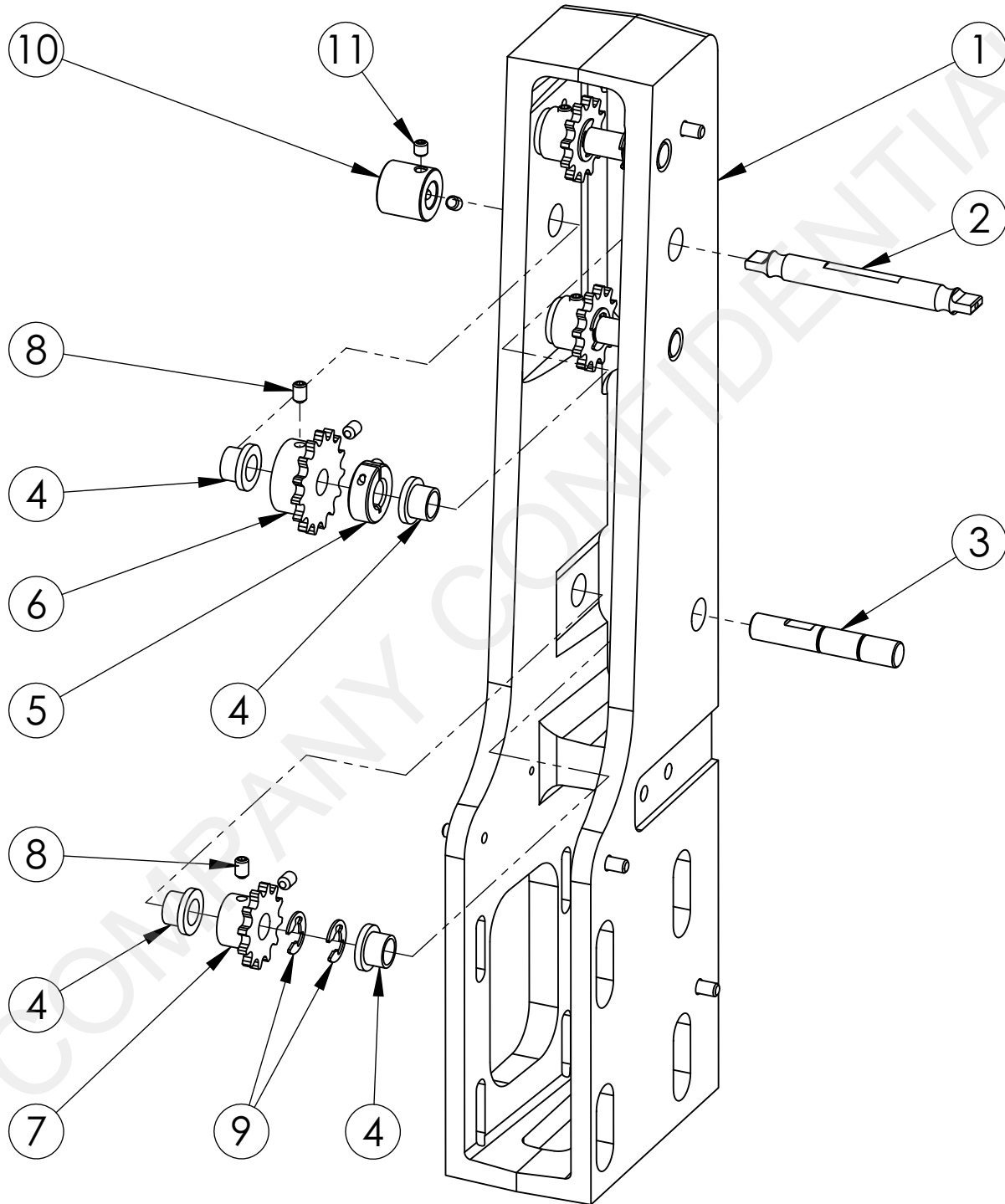



DRIVE ASSEMBLY - BATTER DRIVE (CONTINUED)

Item	Description	Part Number	Quantity
1	Bearing Housing, Rear	102207	1
2	Drive Shaft	500315	1
3	Idler Shaft	101832	3
4	Flange Bearing	101979	8
5	Split Collar	122038	1
6	Sprocket, 15 Tooth	501613	1
7	Sprocket, 12 Tooth	501611	3
8	Sprocket Set Screw 1/4-20 x 3/8"	120081	8
9	Retaining Ring	122047	6
10	Guide Sleeve	500307	1
11	Set screw 1/4-20 x 1/4"	123131	2



DRIVE ASSEMBLY - DRIVE MOTOR AND CHAIN

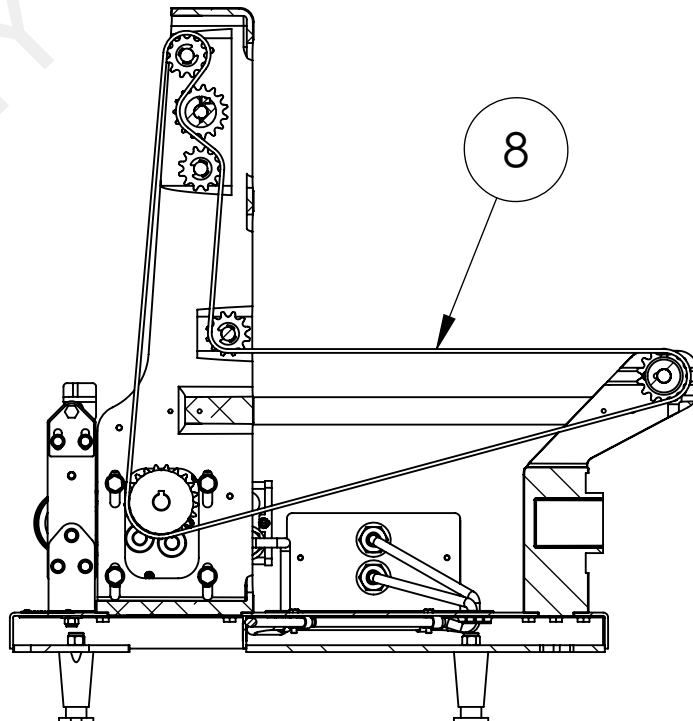
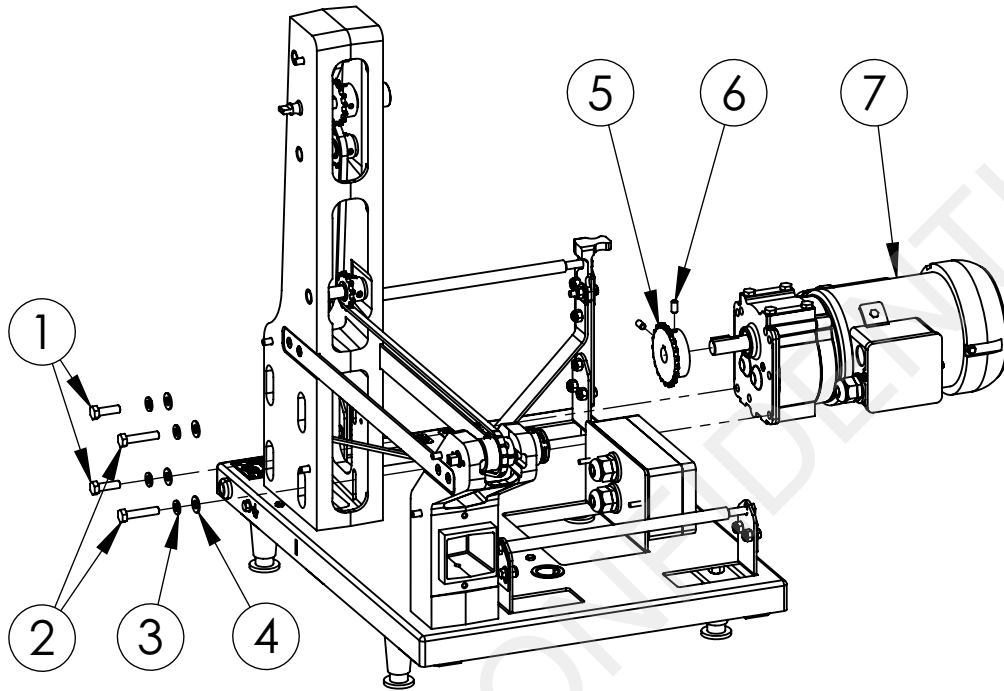



DRIVE ASSEMBLY - DRIVE MOTOR AND CHAIN (CONTINUED)

Item	Description	Part Number	Quantity
1	Hex Head Screw 5/16-18 x 1"	120020	2
2	Hex Head Screw 5/16-18 x 1.5"	120030	2
3	Lock Washer 5/16"	120223	4
4	Flat Washer 5/16"	120258	4
5	Sprocket, 21 Tooth, 115V	102053	1
5a	Sprocket, 25 Tooth, 230V	100421	1
6	Set Screw 1/4-20 x 1/2"	123108	2
7	Gear Motor Assembly	501849	1
8	Chain, Long Assembly #35, 3/8 Pitch, 115V	502055	1
8a	Chain, Long Assembly #35, 3/8 Pitch, 230V	501778	1



BREADER CONVEYOR - EXTERNAL PARTS

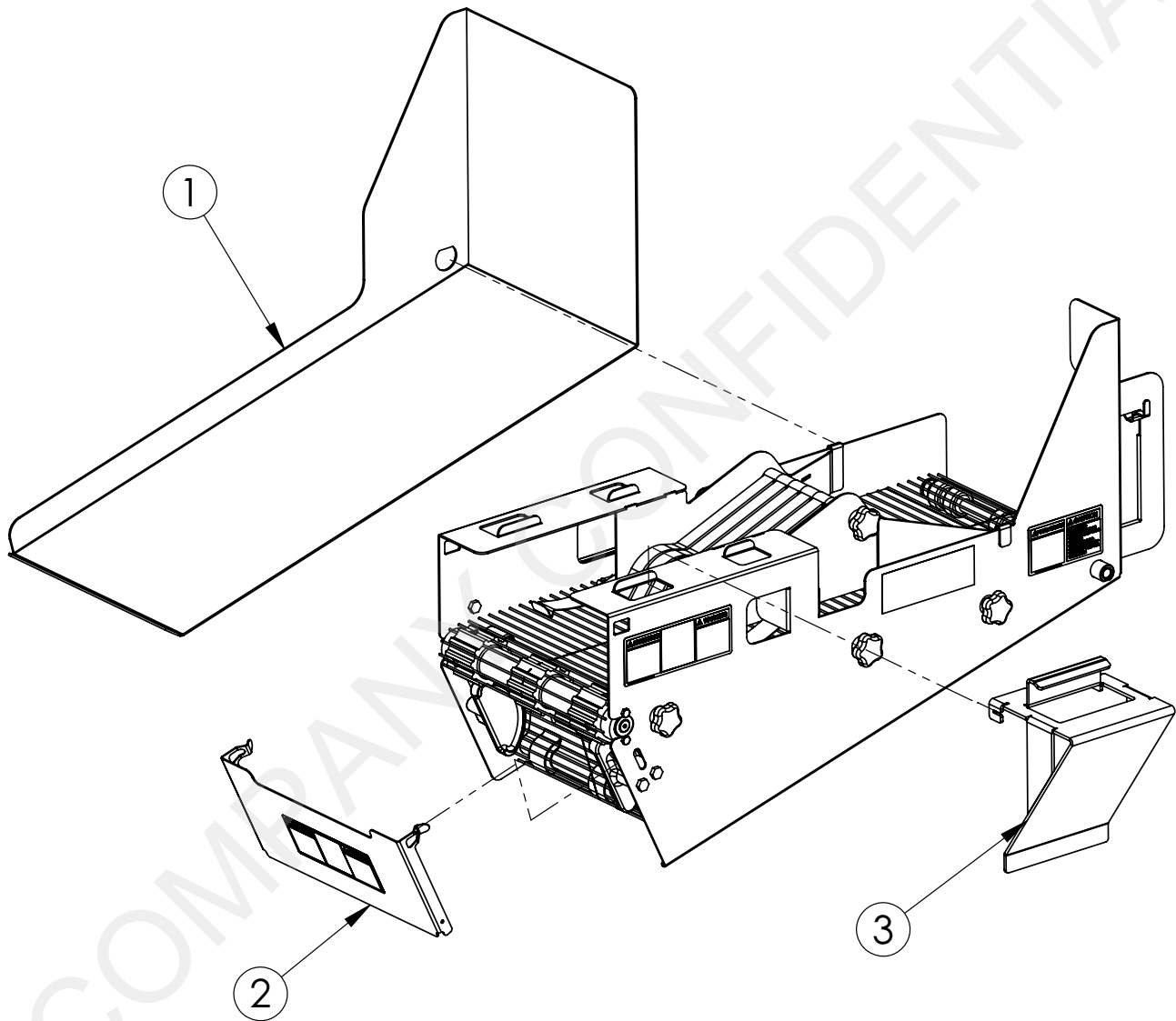

BREADER CONVEYOR - EXTERNAL PARTS (CONTINUED)

Item	Description	Part Number	Quantity
1	Side Rail, LH	102986	1
1	Side Rail, BB-2	103658	1
2	Discharge Tray, No Lip, English/Spanish	501905	1
--	Discharge Tray, No Lip, English/French	103642	1
3	Pan Bracket	501767	1



BREADER CONVEYOR - INTERNAL PARTS

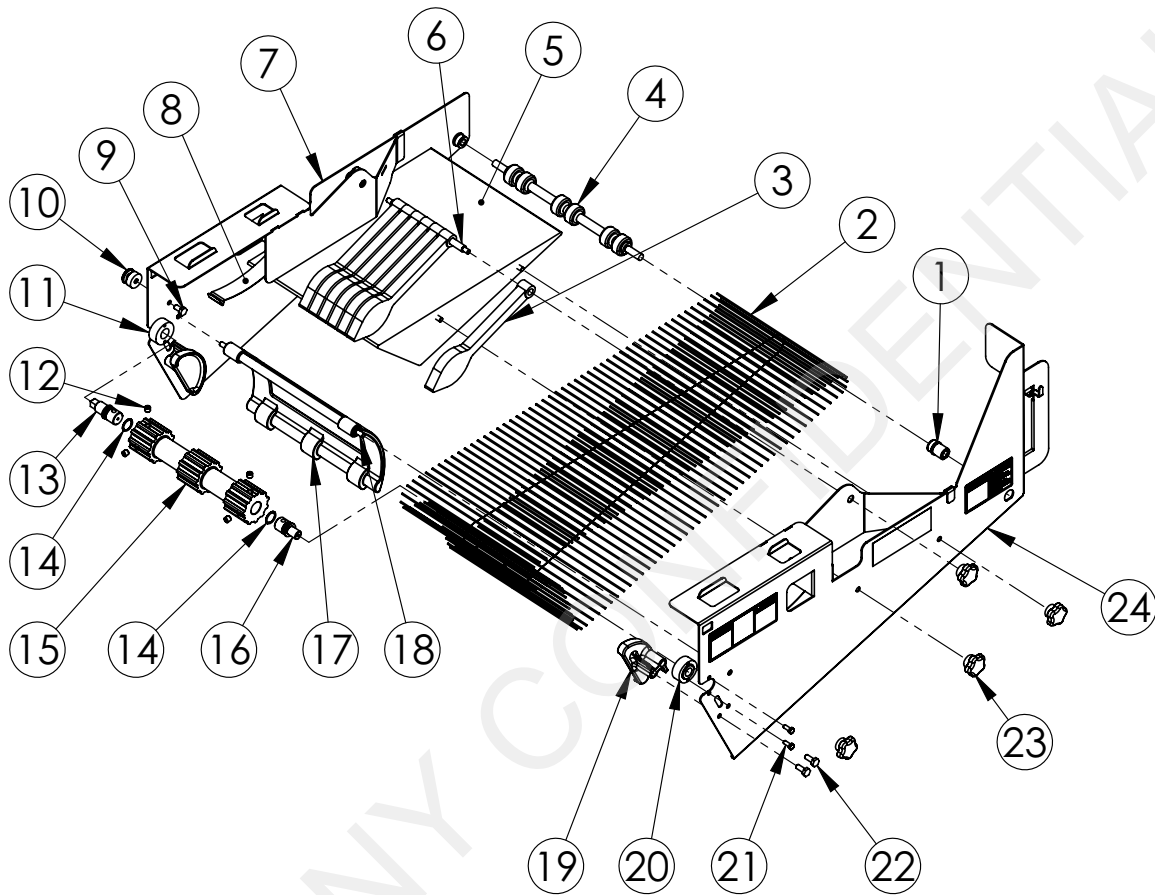



BREADER CONVEYOR - INTERNAL PARTS (CONTINUED)

Item	Description	Part Number	Quantity
1	Bearing Assembly (.375 I.D.)	501069	2
2	Kit, Endless Breeder Belt	501592	1
3	Long Paddle	501742	7
4	Support Shaft	501173	1
5	Breeder Pan	501853	1
6	Paddle Shaft	500800	1
7	Rail, Internal	102975	1
--	Rail, Internal, BB-2	103659	1
8	Vibrator Spring, HD	501944	2
9	Hex Head Screw 1/4-20 x 1/2"	121419	1
10	Locking Shaft	501016	1
11	Bearing, (5/8" I.D.)	501380	1
12	Set Screw 5/16-18 x 1/2"	123113	4
13	Sprocket Mount, Square End	101916	1
14	O-Ring	122328	2
15	Sprocket, Breeder	101904	1
16	Sprocket Mount, Round End	101920	1
17	Deflector	102130	1
18	Shaft, Deflector Mounting	500327	1
19	Idler Block	101932	2
20	Bearing, (1/2" I.D.)	501375	1
21	Hex Head Screw #10-24 x 1/2"	120785	2
22	Hex Head Screw 1/4-20 x 5/8"	120587	2
23	Knob	501475	8
24	Side Rail, RH, English/Spanish	103625	1
--	Side Rail, RH, English/French	103638	1
--	Side Rail, BB-2 English/Spanish	104141	1



BATTER CONVEYOR COMPONENTS

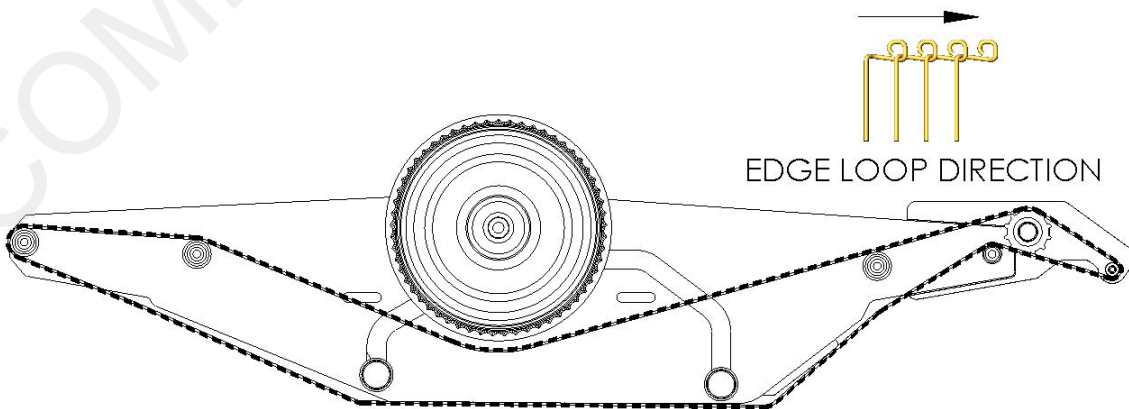
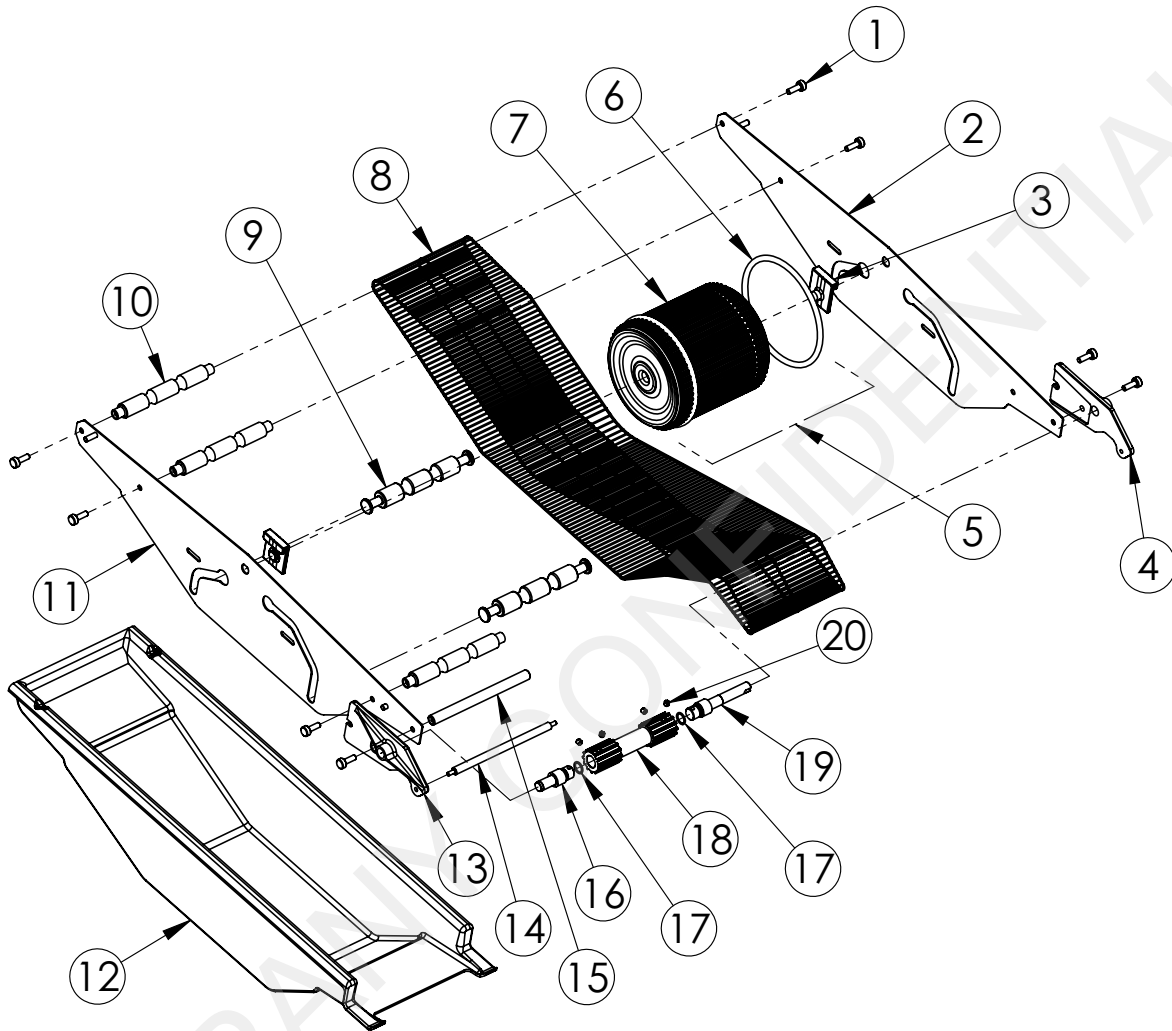



BATTER CONVEYOR COMPONENTS (CONTINUED)

Item	Description	Part Number	Quantity
1	Thumbscrew, Knurled	122764	8
2	Side Left Hand	102057	1
3	Wheel Mount	100598	2
4	Arm, Short LH Non-Adjustable	501255	1
5	Wheel Assembly with O-Rings	100031	1
6	O-Ring, Black	501619	2
7	Batter Wheel	100726	1
8	Belting - Endless Batter	501272	1
9	Tensioner Bar	102058	2
10	Cross Rod	500287	3
11	Side Right Hand	102056	1
12	Batter Tank, RH	103624	1
13	Arm, Short RH Non-Adjustable	501254	1
14	Roller, Fixed	500545	1
15	Rod	500288	1
16	Batter Shaft, Short, Batter Sprocket	101973	1
17	O-Ring	102030	2
18	Batter Sprocket	101905	1
19	Batter Shaft, Long, batter Sprocket	101974	1
20	Set Screw 1/4-20 x 1/4"	123131	4



ELECTRICAL COMPONENTS - POWER CORD - BB-1

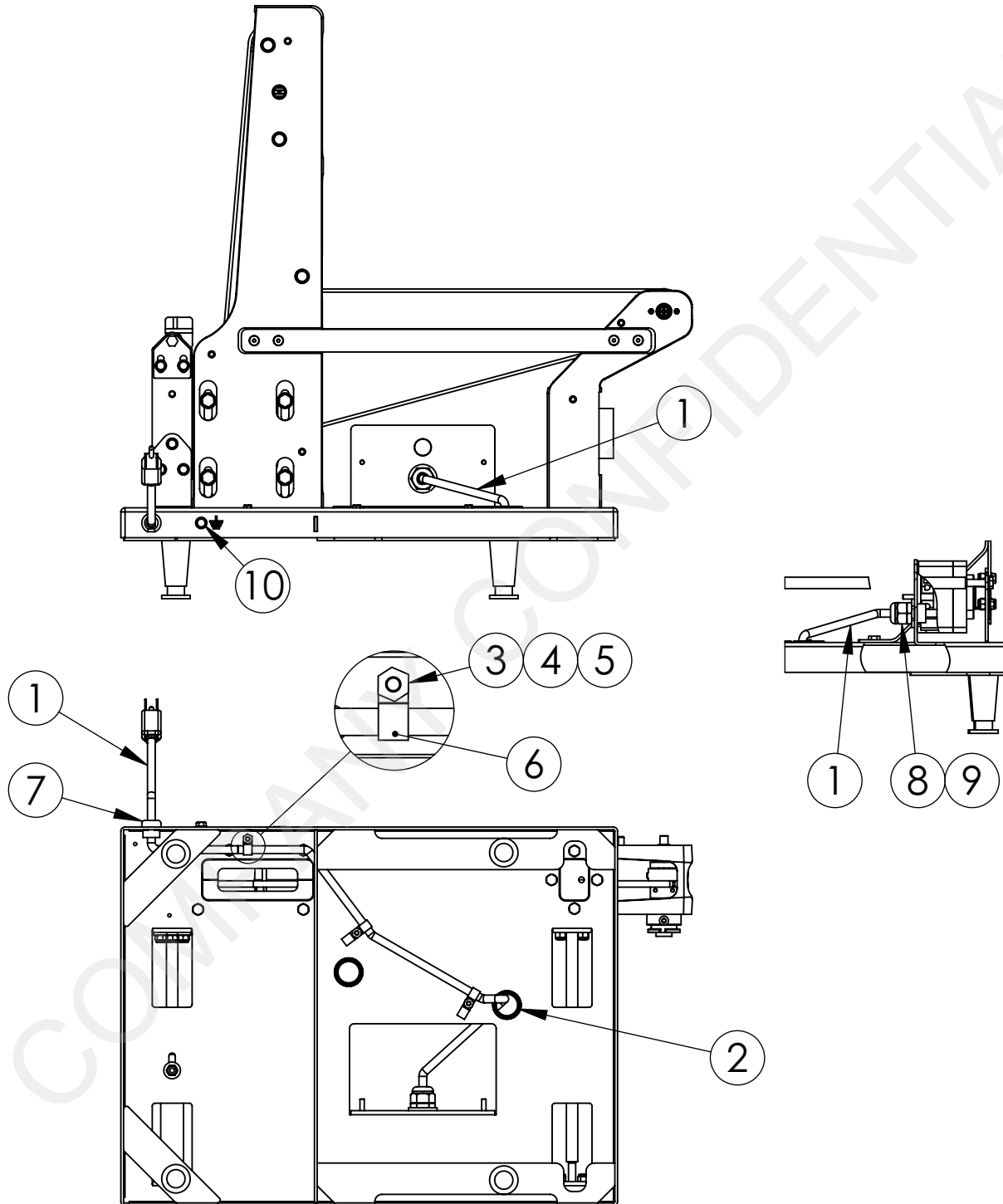



**ELECTRICAL COMPONENTS - POWER CORD - BB-1
(CONTINUED)**

Item	Description	Part Number	Quantity
1	Cordset Power Unit	500760	1
2	Bushing Snap, 5/16	124744	1
3	Nut, #10-24 Standard Hex	120330	3
4	Screw. #10-24 X 3/4"	120759	3
5	Washer, Plain, #10	120281	3
6	Clamp Cable, 3/8	125078	3
7	Bushing, Strain Relief	124746	1
8	Connector, Straight, 1/2	124751	1
9	Seal, 1/2 Conduit	105245	1
10	Hex Washer Head Screw 1/4-20 x 1/2"	123234	1



ELECTRICAL COMPONENTS - SWITCH / MOTOR CORD - BB-1

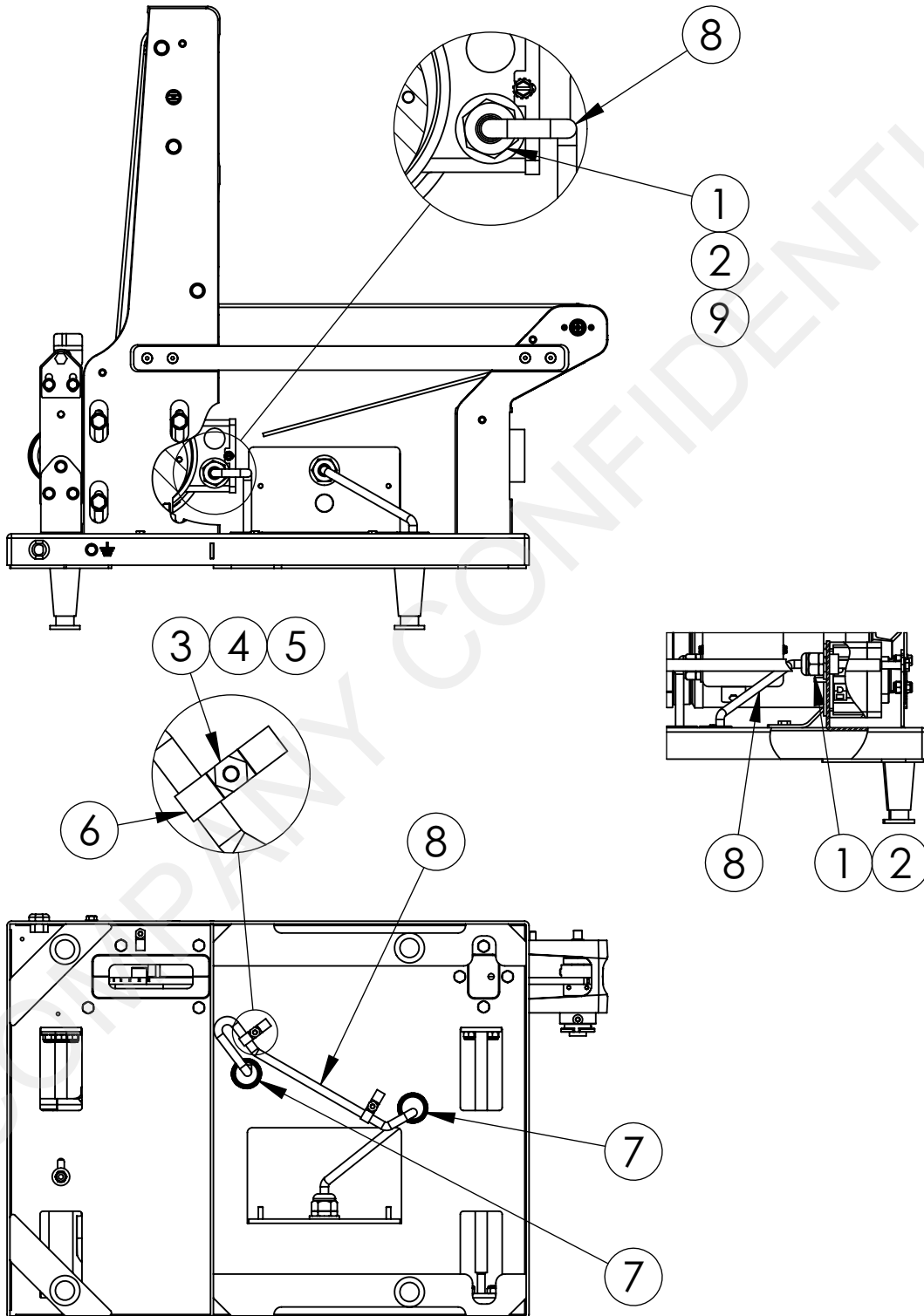

**ELECTRICAL COMPONENTS - SWITCH / MOTOR CORD - BB-1
(CONTINUED)**

Item	Description	Part Number	Quantity
1	Connector, Straight, 1/2"	124751	2
2	Seal, 1/2 Conduit	105245	2
3	Nut, #10-24 Standard Hex	120330	2
4	Screw, 10-24 X 3/4"	120759	2
5	Washer, Plain #10	120281	2
6	Cable Clamp	123831	2
7	Bushing, Snap	124744	2
8	Cord, Motor On/Off Switch	502006	1
9	Nut, Lock, 1/2 Conduit	122653	1



ELECTRICAL COMPONENTS - CAPACITOR AND SWITCH - BB-1

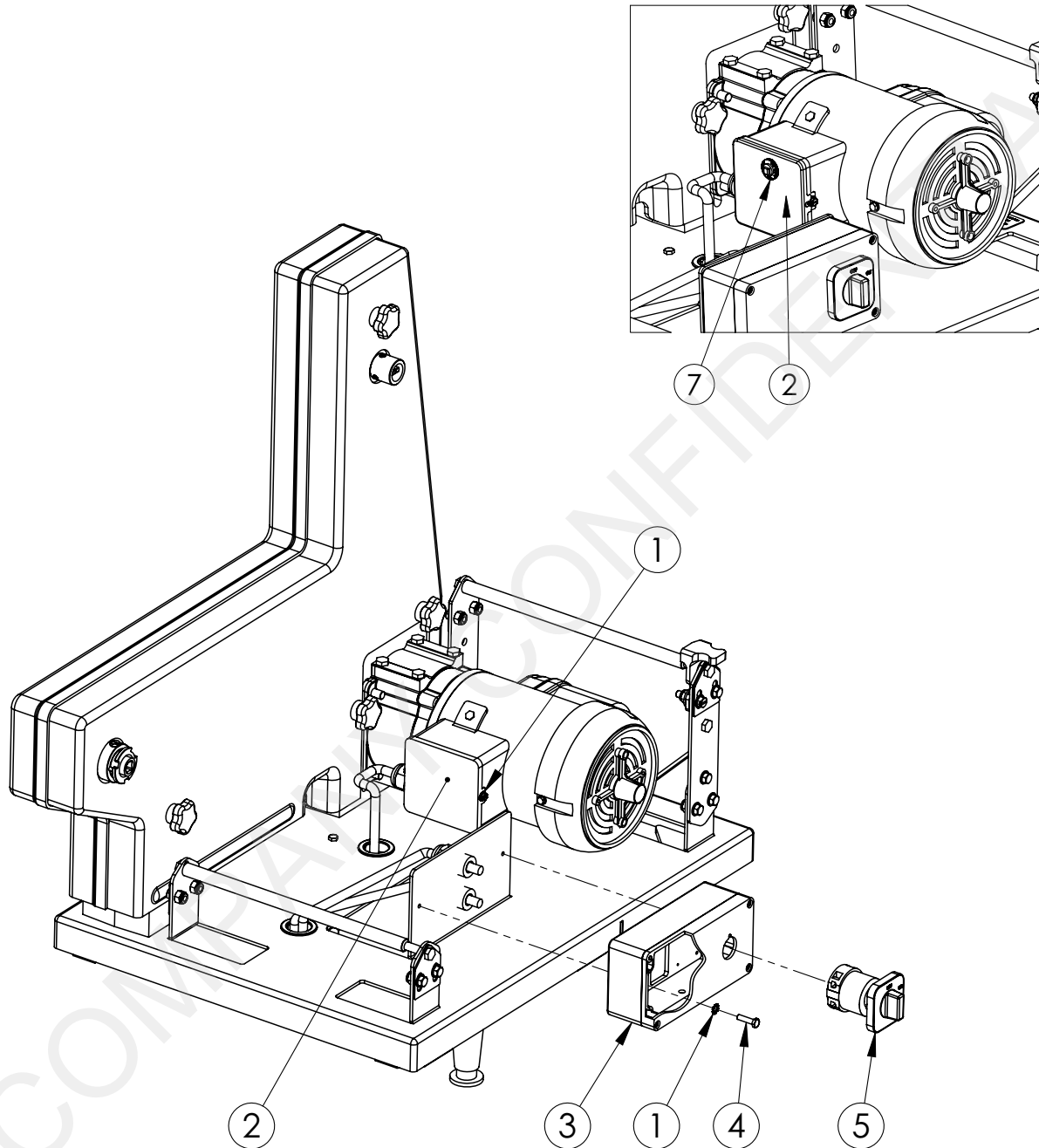

**ELECTRICAL COMPONENTS - CAPACITOR AND SWITCH - BB-1
(CONTINUED)**

Item	Description	Part Number	Quantity
1	Washer, External Tooth, #10	120232	3
2	J-Box Cover	500842	1
--	J-Box Cover (CANADA)	500847	1
3	Enclosure, Switch	502008	1
4	Screw, #10-24 x 3/4"	120759	2
5	Switch, 2-position Cam With Plate	124750	1
6	Capacitor (Not Shown)	501066	1
7	Circuit Breaker Assembly (CANADA)	500843	1



ELECTRICAL COMPONENTS - POWER CORD - BB-2

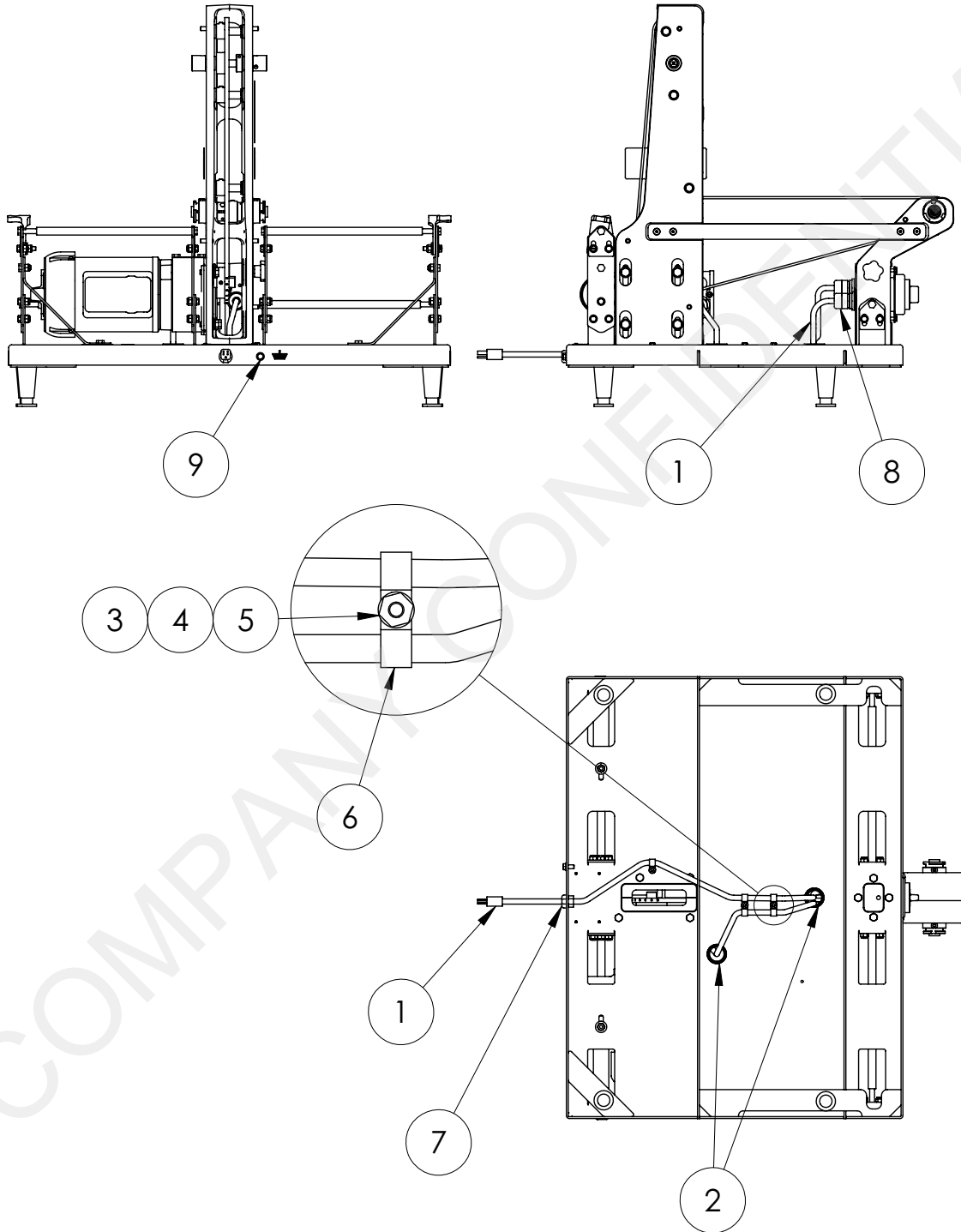

**ELECTRICAL COMPONENTS - POWER CORD - BB-2
(CONTINUED)**

Item	Description	Part Number	Quantity
1	Cordset Power Unit	500760	1
2	Bushing Snap, 5/16	124744	2
3	Nut, #10-24 Standard Hex	120330	3
4	Screw, #10-24 X 3/4"	120759	3
5	Washer, Plain, #10	120281	3
6	Clamp Cable, 3/8	125078	3
7	Bushing, Strain Relief	124746	1
8	Connector, Strain Relief, Snap-in	103985	1
9	Hex Washer Head Screw 1/4-20 x 1/2"	123234	1



ELECTRICAL COMPONENTS - SWITCH / MOTOR CORD - BB-2

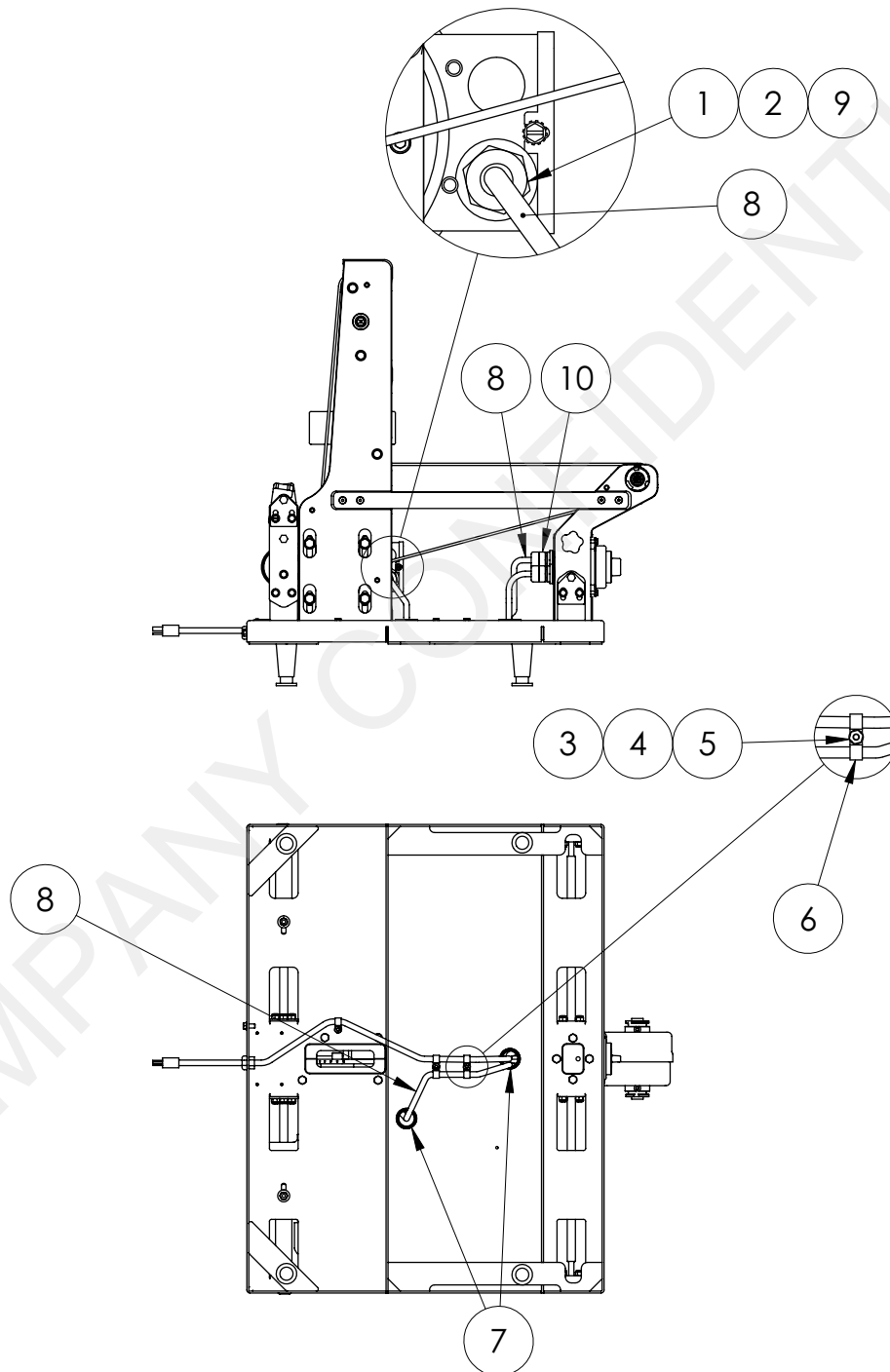



ELECTRICAL COMPONENTS - SWITCH / MOTOR CORD - BB-2 (CONTINUED)

Item	Description	Part Number	Quantity
1	Connector, Straight, 1/2"	124751	1
2	Seal, 1/2 Conduit	105245	1
3	Nut, #10-24 Standard Hex	120330	2
4	Screw, 10-24 X 3/4"	120759	2
5	Washer, Plain #10	120281	2
6	Cable Clamp	123831	2
7	Bushing, Snap	124744	2
8	Cord, Motor On/Off Switch	502006	1
9	Nut, Lock, 1/2 Conduit	122653	1
10	Connector, Strain Relief, Snap-in	103985	1



ELECTRICAL COMPONENTS - CAPACITOR AND SWITCH - BB-2

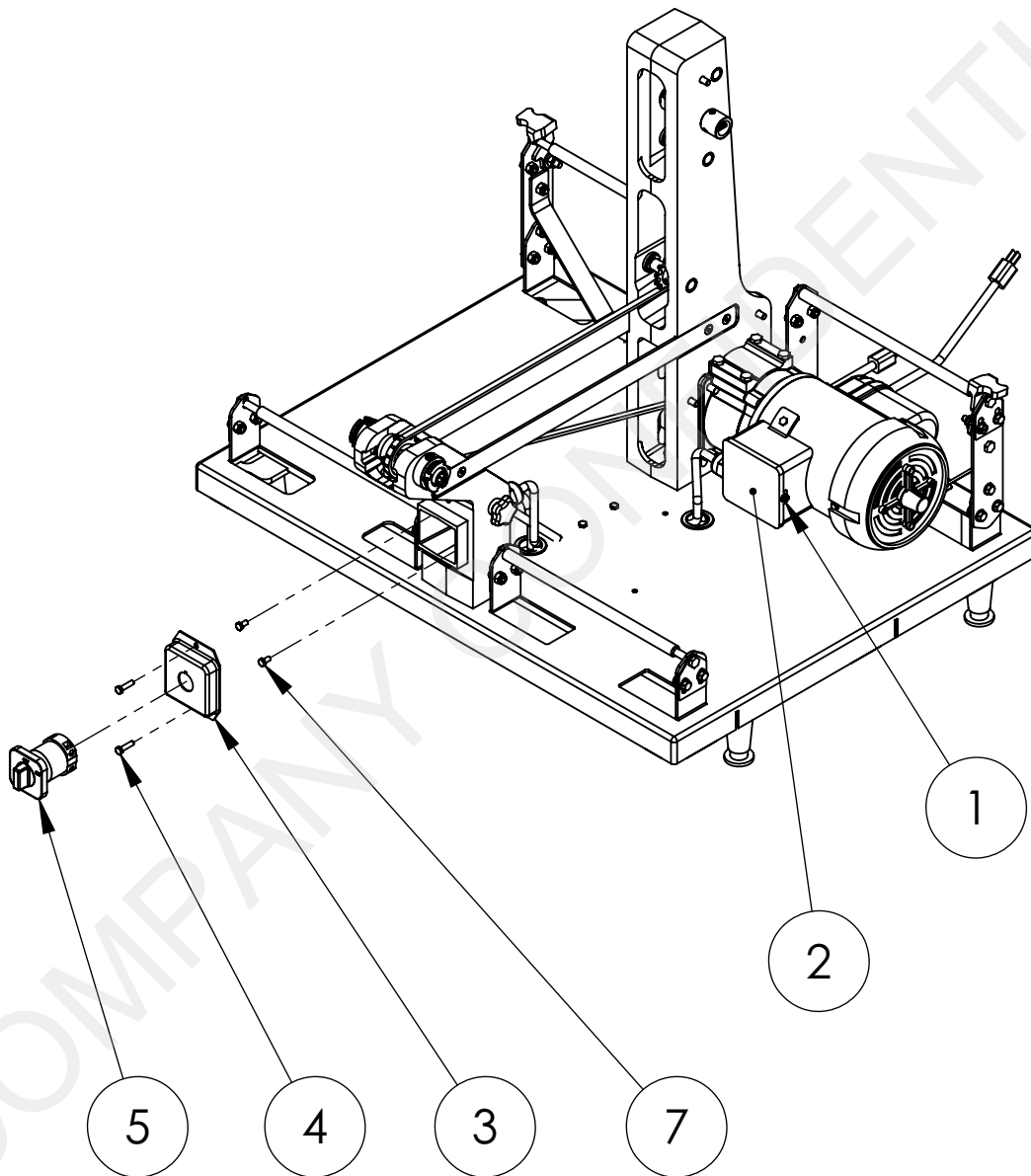

**ELECTRICAL COMPONENTS - CAPACITOR AND SWITCH - BB-2
(CONTINUED)**

Item	Description	Part Number	Quantity
1	Washer, External Tooth, #10	120232	3
2	J-Box Cover	500842	1
3	Cover Assembly with Gasket	500344	1
4	Screw, #10-24 x 3/4"	120759	2
5	Switch, 2-position Cam With Plate	124750	1
6	Capacitor (Not Shown)	501066	1
7	Screw, #10-24 x 3/8"	120760	2



ELECTRICAL COMPONENTS - POWER CORD 230V - BB-1F

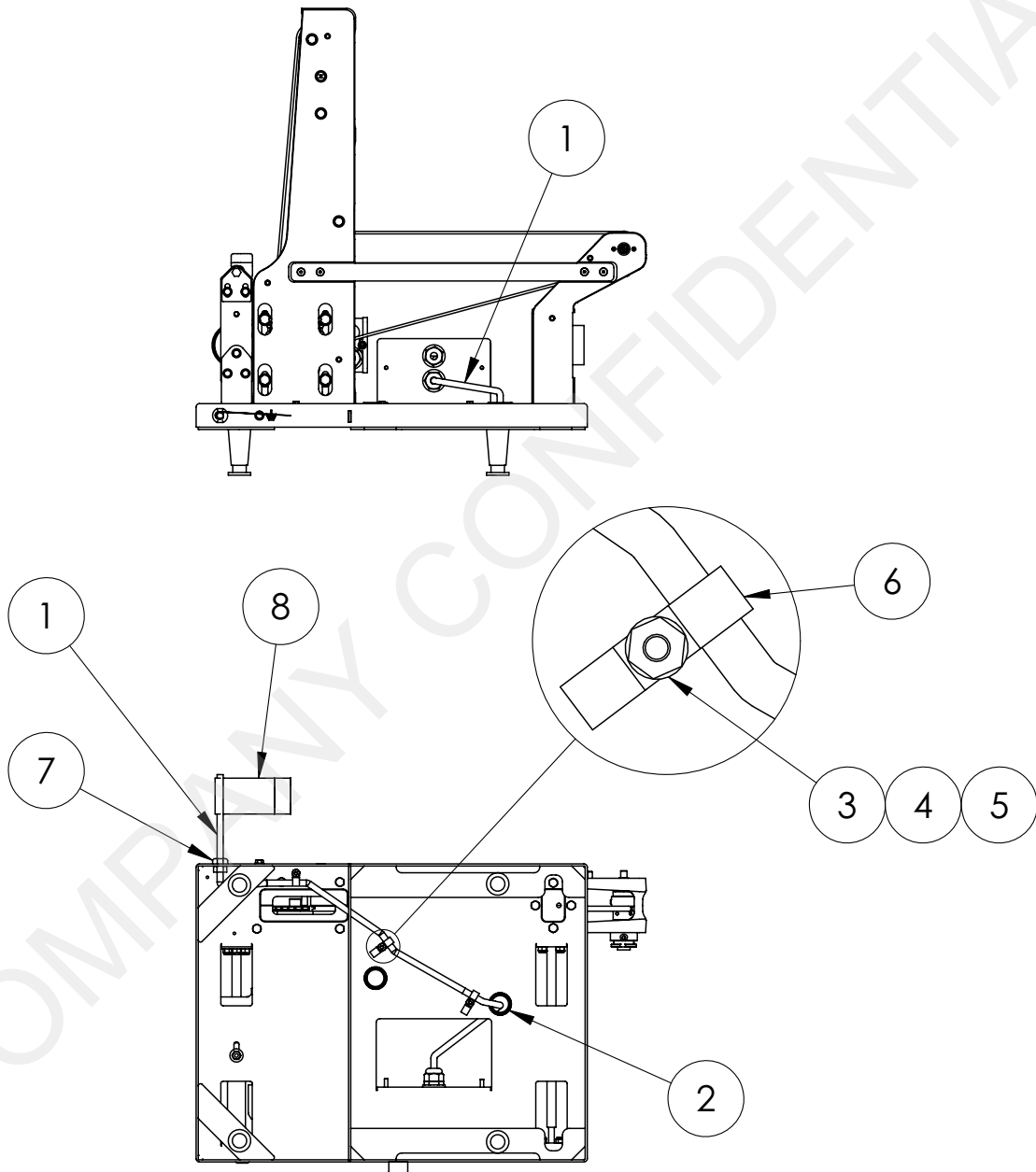

**ELECTRICAL COMPONENTS- POWER CORD 230V - BB1-F
(CONTINUED)**

ITEM	Description	230V Part Number	QTY
1	Cordset Power Unit	500469	1
2	Bushing Snap, 5/16	124744	2
3	Nut, #10-24 Standard Hex	120330	1
4	Screw, #10-24 X 3/4"	120759	1
5	Washer, Plain, #10	120281	1
6	Clamp Cable, 3/8	125078	1
7	Bushing, Strain Relief	124746	1



ELECTRICAL COMPONENTS - MOTOR CORD 230V - BB1-F

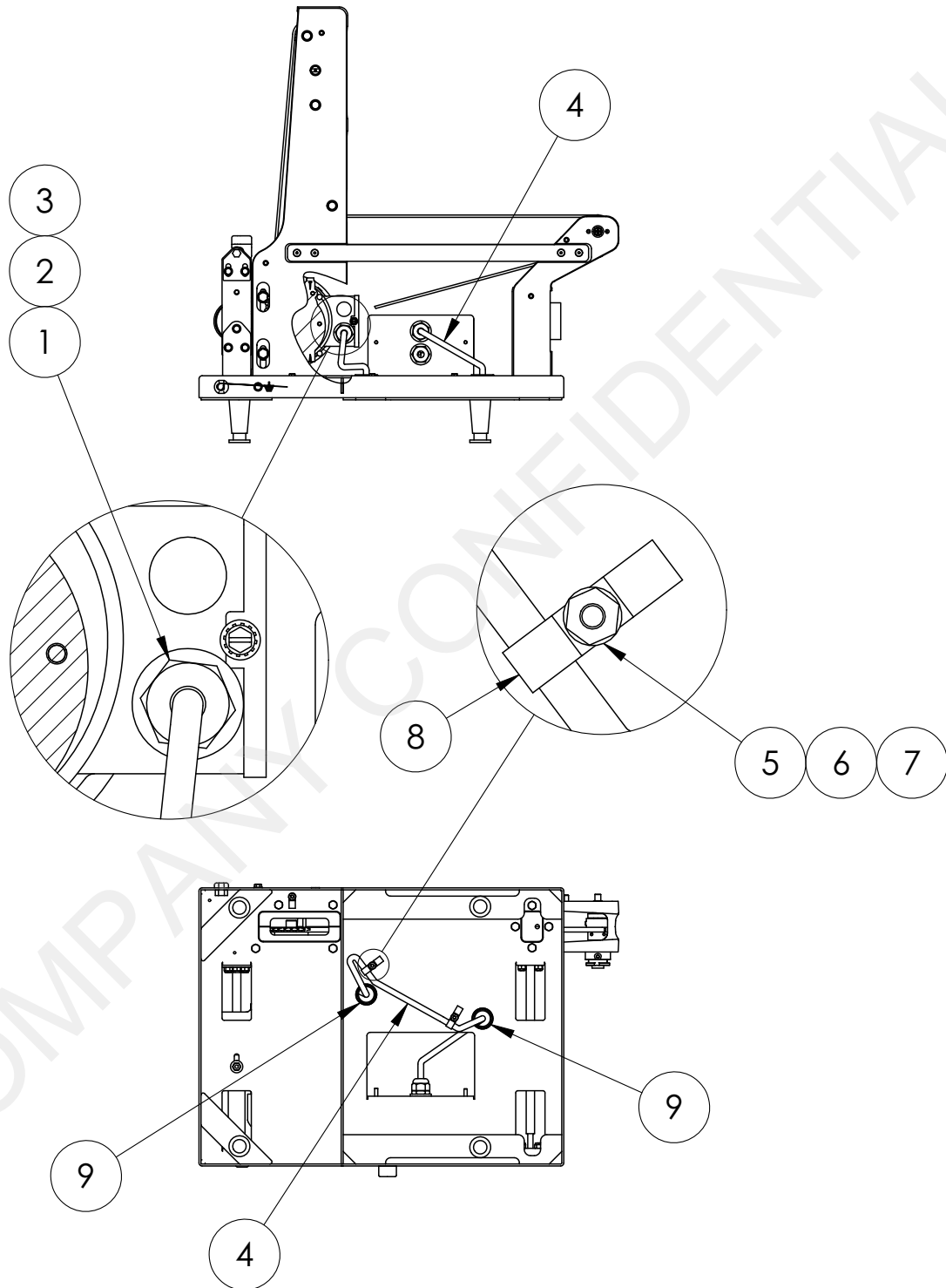



**ELECTRICAL COMPONENTS - MOTOR CORD 230V - BB1-F
(CONTINUED)**

Item	Description	230V Part Number	QTY
1	Connector, Straight, 1/2"	124751	1
2	Seal, 1/2 Conduit	105245	1
3	Nut, Lock, 1/2 Conduit	122653	1
4	Cord, Motor	104167	1
5	Nut, #10-24 Standard Hex	120330	1
6	Screw, #10-24 x 3/4"	120759	1
7	Washer, Plain, #10	120281	1
8	Clamp, Cable, 3/8	125078	1
9	Bushing Snap, 5/16	124744	2



ELECTRICAL COMPONENTS - CAPACITOR AND SWITCH 230V - BB1-F

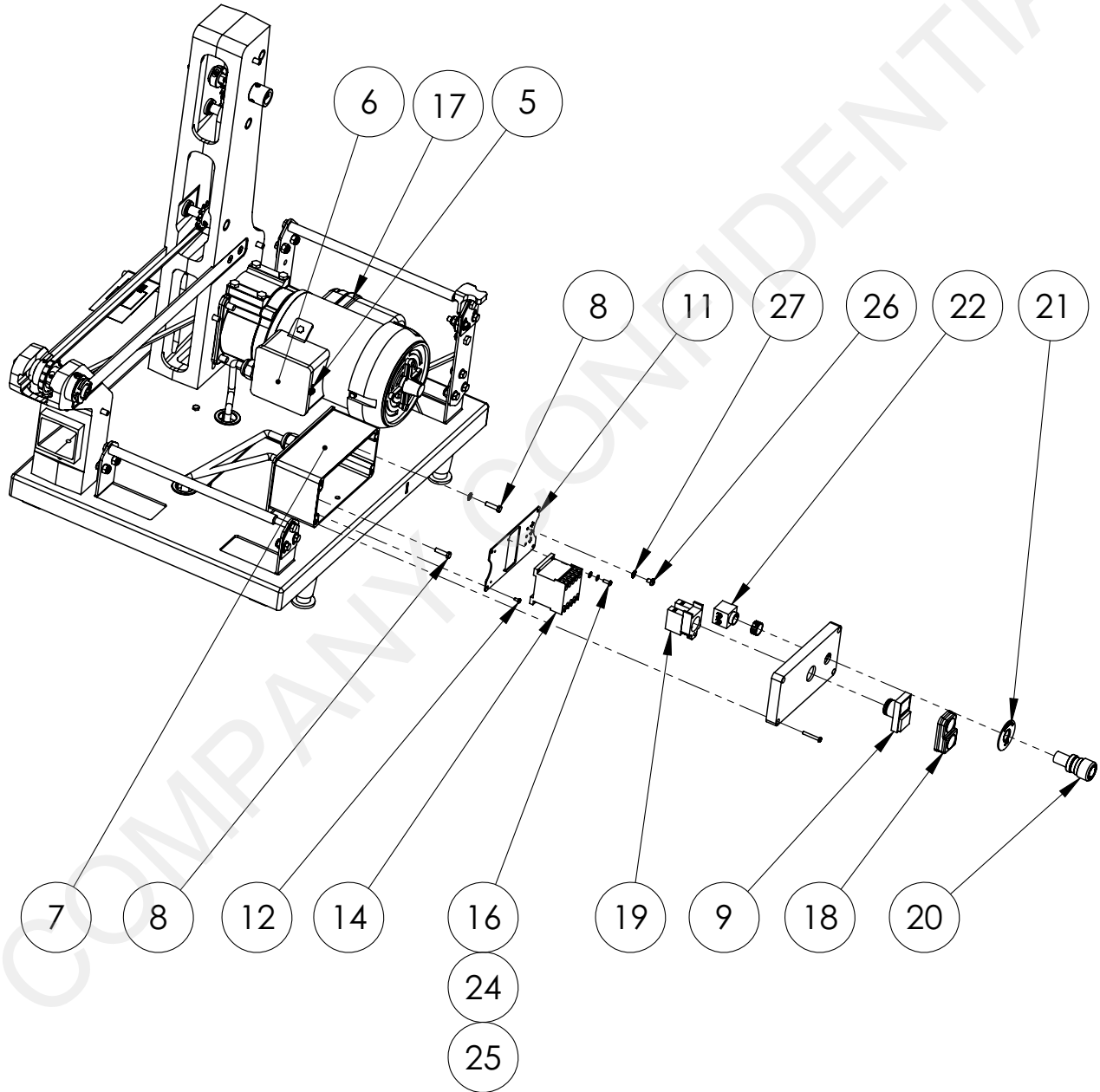

ELECTRICAL COMPONENTS - CAPACITOR AND SWITCH 230V - BB1-F (CONTINUED)

Item	Description	230V Part Number	QTY
1	Wire - White, 6" - NOT SHOWN	501755	2
2	Wire - Red/Black, 7" - NOT SHOWN	501754	1
5	Washer, External Tooth, #10	120232	2
6	J-Box Cover	500842	1
7	Enclosure, E-Stop	104153	1
8	Screw, Hex, 10-24 x 3/4"	120759	2
9	Switch, Drop Out	501763	1
9a	Wire - Red 5" - NOT SHOWN	501756	2
11	Panel, Enclosure	104154	1
12	Screw, M3 x 6mm	155021	4
13	Wire Assembly 5" - NOT SHOWN	500712	1
14	Mini Contactor	124907	1
16	Pan Head #6-32 x 3/8"	120780	4
17	Capacitor	501066	1
18	Boot, Drop-out	501681	1
19	Element, Switching, Drop-out	501680	1
20	Switch, E-stop	501834	1
21	Plate, E-stop	501836	1
22	Element, Switching, E-stop	501835	1
23	Wire, Black, 7" - NOT SHOWN	501985	2
24	Lock Washer, #6	120233	4
25	Washer	123524	4
26	Screw, #10-32 x 1/4"	123256	3
27	Washer External Tooth #10	120232	4



SAFETY LABELS

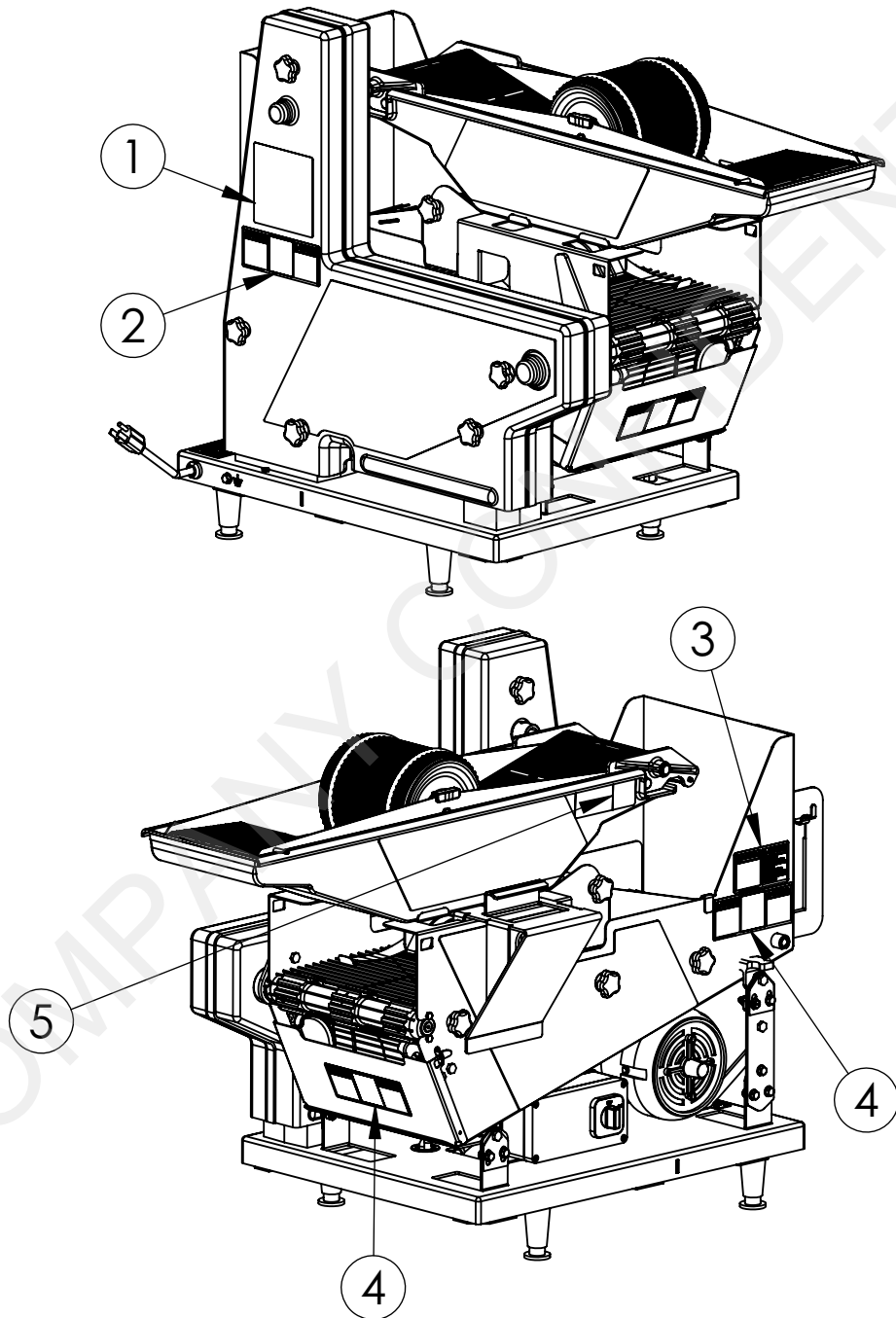



SAFETY LABELS (CONTINUED)

Item	Description	Part Number	Quantity
1	Label, Frame Wash Down	501630	1
2	Label, Chain Hazard	500636	2
3	Label, Washing Caution	501425	1
4	Label, Pinch Hazard	500637	2
5	Label, Batter Belt Path	500845	1



OPTIONAL EQUIPMENT AVAILABLE

Item	Description	Part Number
1	Case of eXtra© Heavy Duty Cleaner	184331
2	eXtra© Heavy Duty Cleaner (1 gallon jug)	184332
3	Grease Gun, Filled (for lubricating breader drive shaft)	501417
4	Triple B Silicone Spray, Case (12 Cans)	185685
5	Kit, Endless Breader Belt, Optimax®	501592
6	Basket, Interlocking	501642
7	Lubrication Kit	501669
8	Triple B Silicone Spray, (1 Can)	502013
9	Scraper, Wheel, Optimax	103612

ELECTRICAL SCHEMATICS

115V/1PH/60Hz Internal Capacitor

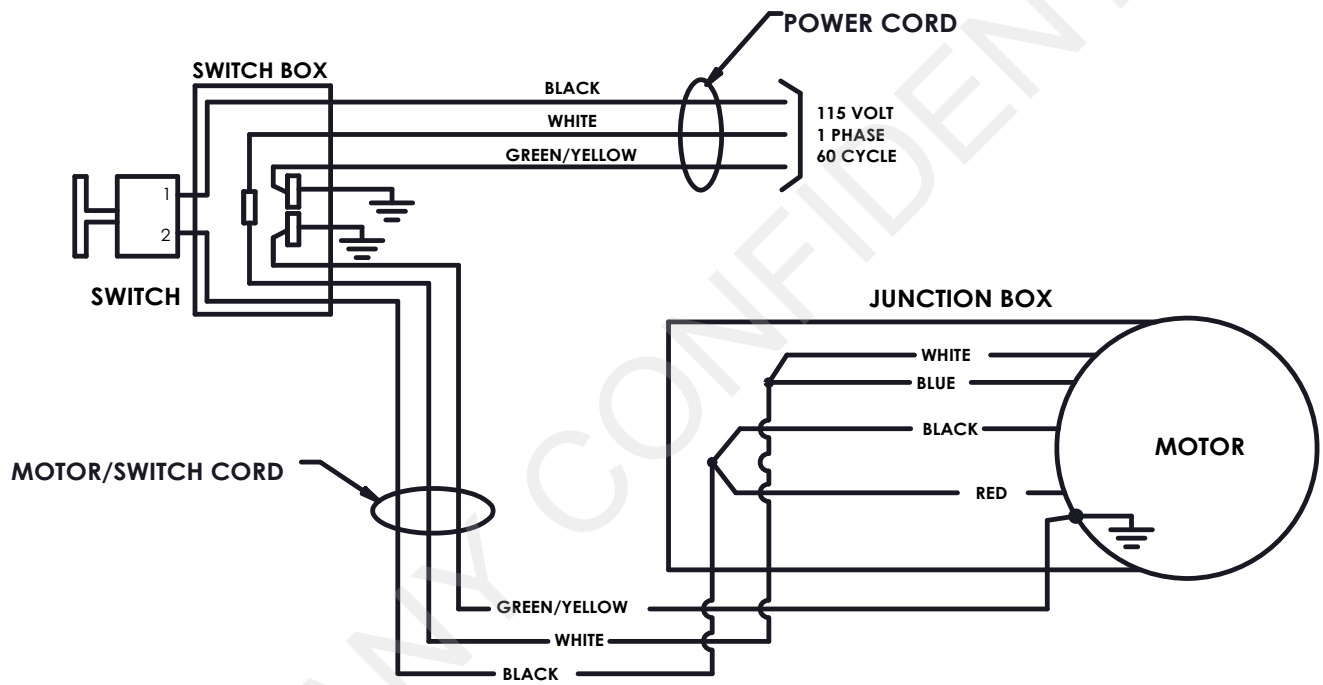

**115V/1PH/60Hz
INTERNAL CAPACITOR**



ELECTRICAL SCHEMATICS (CONTINUED)

115V/1PH/60HZ Internal Capacitor (Canadian)

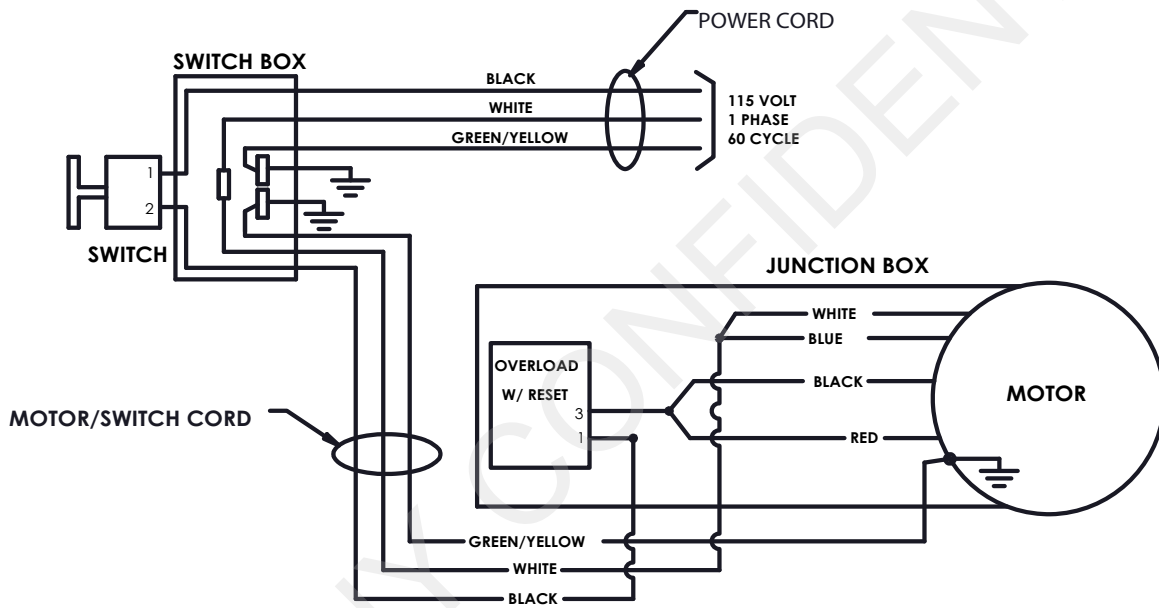

115V/1PH/60Hz (CANADIAN UNITS ONLY)

INTERNAL CAPACITOR

ELECTRICAL SCHEMATICS (CONTINUED)

230V/1PH/50HZ Internal Capacitor

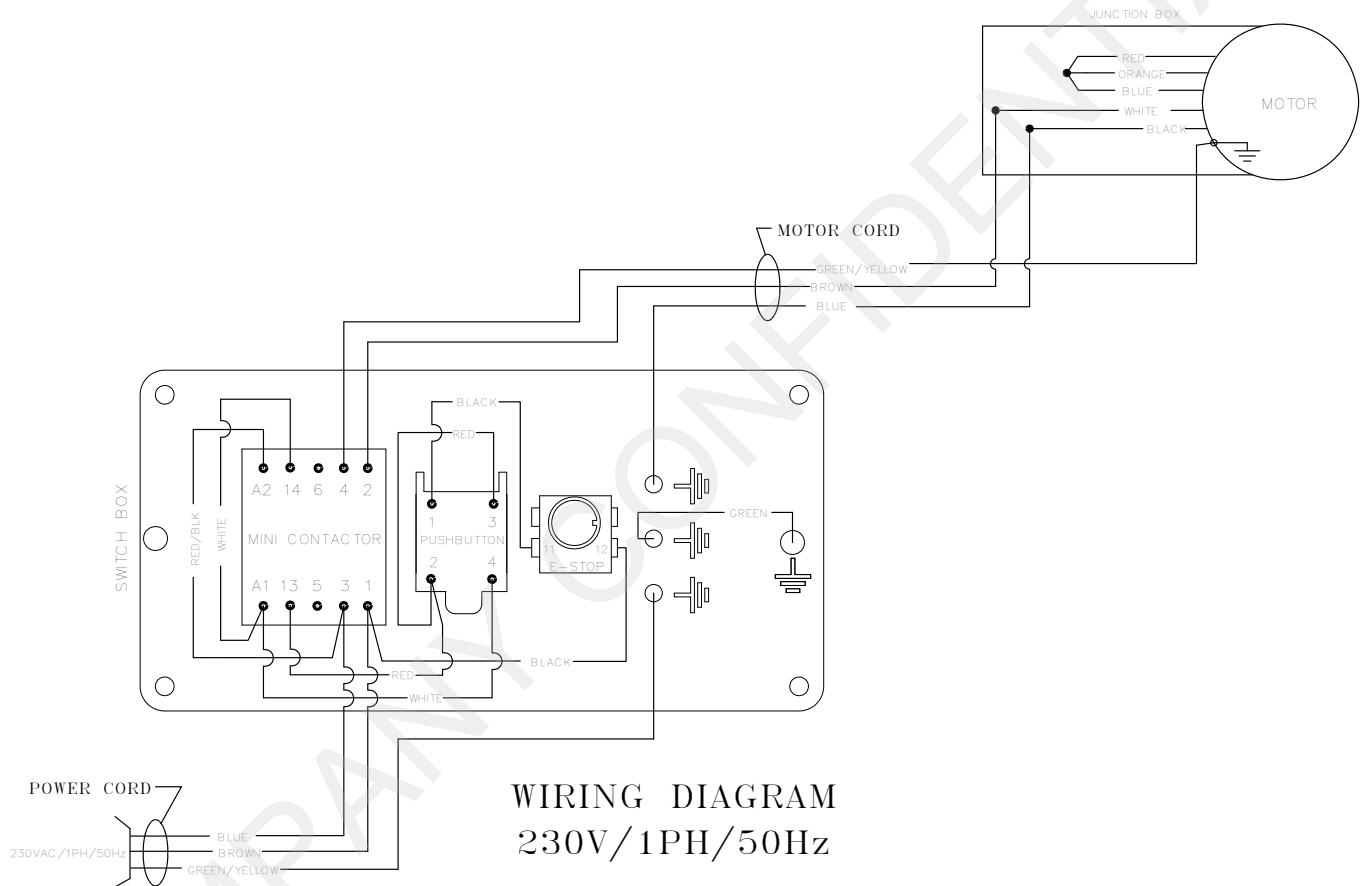



THIS PAGE INTENTIONALLY LEFT BLANK

COMPANY CONFIDENTIAL



Section 8

Contact and Document Information

CONTENTS OF THIS SECTION

Contact Address and Phone	8-2
Document Identification	8-2
Software and Duplication	8-2
Service Providers	8-3

COMPANY CONFIDENTIAL



CONTACT ADDRESS AND PHONE

For additional information, service providers, technical support and spare parts, contact your Regional Manager, Distributor, or Bettcher Industries Representative:

Bettcher Industries, Inc.
P.O. Box 336
Vermilion, Ohio 44089
USA
Tel: +1 440/965-4422
Fax: +1 440/328-4535

BETTCHER GmbH
Pilatusstrasse 4
CH-6036 Dierikon
SWITZERLAND
Tel: +011-41-41-348-0220
Fax: +011-41-41-348-0229

Bettcher do Brasil Comércio de Máquinas Ltda.
Av. Fagundes Filho, 145 Cj 101/102 - São Judas
São Paulo - SP
CEP 04304-010 - BRASIL
Tel: +55 11 4083 2516
Fax: +55 11 4083 2515

DOCUMENT IDENTIFICATION

Copies of this Operation Instruction may be ordered by quoting the Document ID as listed below:

Document ID:	Manual #103006
Document Description:	Operating Instructions and Spare Parts List For Optimax [®]
Issued:	February 2, 2015

SOFTWARE AND DUPLICATION

For more information, contact your local Representative or:

Bettcher Industries, Inc.
Administrative Assistant/Engineering Department
PO Box 336
Vermilion, Ohio 44089
USA



SERVICE PROVIDERS



NORTH AMERICA AUTHORIZED SERVICE AGENCY LISTING

Bettcher Industries, Inc. **Foodservice Equipment**

ALABAMA (AL)

All ZIP Codes

South Eastern Food Equipment
102 2nd Street
PO Box 357
Helena, AL 35080
205-663-7653
205-664-3604 (fax)
sebutcher@charter.net

ALASKA (AK)

All ZIP Codes

Restaurant Appliance Service
Main office:
22322 20th Ave SE
Bothell, WA 98011-8418
206-524-8200
425-486-8544 (fax)
866-770-2022
tom.mcpeters@3wire.com

ARIZONA (AZ)

All ZIP Codes

Service Solutions Group
Main office:
4832 South 35th Street
Phoenix, AZ 85040
602-234-2443
602-232-5862 (fax)
800-824-8875
tim.harper@servicesg.com

Branch office:

1121 W. Grant Rd. #410
Tucson, AZ 85705
520-629-0040
520-629-0622 (fax)
800-300-3337 (SW AZ)
doug.hargadon@servicesg.com

ARKANSAS (AR)

ZIP Codes 71600-72299, 72300-72499, 72500-72999

Scott Service Company
7123 Interstate 30
Suite 51
Little Rock, AR 72209
501-562-1863
501-562-2308 (fax)
vince.004@sbcglobal.net

Bromley Parts and Service
1000 Ringo Street
Little Rock, AR 72202
501-374-0281
501-374-8352
diane@bromleyparts.com

CALIFORNIA (CA)

ZIP Codes 90000-91899, 92300-93599

Industrial Electric Service
5662 Engineer Drive
Huntington Beach, CA 92649
714-379-7100
714-379-7109 (fax)
800-45-SERVE
Debbie.palmer@nacps.com

Service Solutions Group
5367 Second Street
Irwindale, CA 91706
626-960-9390
626-337-4541 (fax)
800-258-6999
larry.matteson@servicesg.com

ZIP Codes 93600-96699

P&D Appliance Service Center
Main office:
100 South Linden Avenue
South San Francisco, CA 94080
650-635-1900
650-635-1919 (parts)
800-424-1414
Sanfran.service@nacps.com

Branch office:

4220 "C" Roseville Road
North Highlands (Sacramento), CA
95660
916-974-2772
916-974-2774 (fax)
800-824-7219
Sacramento.service@nacps.com

Cal-west Service Inc
6405 Golden Gate Drive
Dublin, CA 94568
925-551-6400
925-551-6444 (fax)
888-306-6401
jmartinez@calwestservice.com

ZIP Codes 91900-92299

Service Solutions Group
5160 Mercury Point #C
San Diego, CA 92111
858-751-0390
858-751-0399 (fax)
steve.ruegsegger@service.com

COLORADO (CO)

All ZIP Codes

Hawkins Commercial
Main Office:
3000 South Wyandot St.
Englewood, CO 80110
303-781-5548
303-761-8861 (fax)
800-624-2117
jeffs@hawkinscommercial.com

Branch Office:

56 Buchanan
Colorado Springs, CO 80907
719-477-1242
719-477-1513 (fax)
Darrell@hawkinscommercial.com

 **BETTCHER Industries, Inc.**
FOODSERVICE GROUP

6801 State Route 60, Birmingham, OH 44816
Phone (440) 965-4422 Fax (440) 965-4900
www.bettcher.com



SERVICE PROVIDERS (CONTINUED)



NORTH AMERICA AUTHORIZED SERVICE AGENCY LISTING, Bettcher Industries, Inc. Foodservice Equipment, Page 2

CONNECTICUT (CT)

All ZIP Codes

Authorized Appliance
Main office:
74 River Street
Rutland, VT 05701
802-775-5588
802-775-9593 (fax)
800-874-1080
bborger@together.net

Branch office:
109B Loomis St
Manchester, CT 06040
860-649-2355
860-646-8926 (fax)
aasc1@together.net

DELAWARE (DE)

All ZIP Codes

Electric Motor Repair
263 Quigley Blvd. Suite 12
New Castle, DE 19720
302-834-5292
302-834-5596 (fax)
888-687-8080
jdriver@emrco.com

DISTRICT OF COLUMBIA (DC)

All ZIP Codes

Daubers Inc.
Main Office:
7645 Dynatech Court
Springfield, VA 22153
703-866-3600
703-866-4071 (fax)
800-554-7788
chuck@daubers.com

Branch Office:
2407 Ownby Lane
Richmond, VA 23220
804-359-9065
804-359-4331 (Fax)
800-273-9593
jim@daubers.com

FLORIDA (FL)

All ZIP Codes

Heritage Service Group of Florida
800-983-9027
866-388-9838 (fax)
fredh@hfse.com

GEORGIA (GA)

ZIP Codes 30000-39999

Heritage Service Group of Atlanta
2100 Norcross Parkway Suite 130
Norcross, GA 30071
800-983-9027
866-388-9838 (fax)
fredh@hfse.com

HAWAII (HI)

All ZIP Codes

Burney's Commercial Service
528 Mokauea Street
Honolulu, HI 96819
808-848-1466
808-848-0545 (fax)
burneyshi@aol.com

IDAHO (ID)

ZIP Codes 83500-83599, 83800-83899

Restaurant Appliance Service
22322 20th Ave SE
Bothell, WA 98011-8418
206-524-8200
425-486-8544 (fax)
866-770-2022
tom.mcpeters@3wire.com

ZIP Codes 83200-83299, 83400-83499

Custom Commercial Service
Main office:
Branch office:
8280 Hwy 200 E
Milltown, MT 59851
406-829-8288
406-829-8290 (fax)
ccsmt@aol.com

ZIP Codes 83300-83399, 83600-83799

Ron's Service
11481 West Fairview Avenue
Boise, ID 83713
208-375-4073
208-375-4402 (fax)
info@ronsservice.com

ILLINOIS (IL)

ZIP Codes 60000-60799, 61100-61199, 61300-61399

General Parts
248 James Street
Bensenville, IL 60106
630-595-3300
630-595-0006 (fax)
800-880-5027 (fax)
800-880-3604
carolw@generalparts.com

ZIP Codes 60900-61099, 61200-61299, 61400-61999, 62300-62799

Dan Cone Group
2408 40th Avenue
Moline, IL 61265
309-797-5323
309-797-3631 (fax)
800-716-7070
cones@cones.com

ZIP Codes 62000-62299, 62800-62899, 62900-62999

Commercial Kitchen Services, Inc.
10667 Midwest Industrial Blvd.
Saint Louis, MO 63132
314-890-0700
314-890-0705 (fax)
800-966-2936
info@cks-stl.com

INDIANA (IN)

ZIP Codes 46000-47099, 47200-47999

General Parts
6226 LaPas Trail
Indianapolis, IN 46268
317-290-8060
317-290-8085 (fax)



SERVICE PROVIDERS (CONTINUED)

NORTH AMERICA AUTHORIZED SERVICE AGENCY LISTING, Bettcher Industries, Inc. Foodservice Equipment, Page 3

800-410-9794
rayh@generalparts.com

ZIP Codes 47100-47199

Service Solutions Group
4283 Produce Road
Louisville, KY 40218
502-964-7007
502-964-7202 (fax)
800-637-6350
don.roenigk@servicesg.com

IOWA (IA)

ZIP Codes 52000-52199, 52600-52899

Dan Cone Group
2408 40th Avenue
Moline, IL 61265
309-797-5323
309-797-3631 (fax)
800-716-7070
cones@cones.com

ZIP Codes 50000-51699, 52200-52599

Lehman Commercial Service
Division of General Parts
1501 Michigan Street
Des Moines, IA 50314
515-243-1974
515-243-1534 (fax)
800-225-2641
janells@generalparts.com

KANSAS (KS)

All ZIP Codes

General Parts

Main Office:
1101 E 13th Street
Kansas City, MO 64106
816-421-5400
816-421-1270 (fax)
800-279-9967
800-279-9968 (fax)
stever@generalparts.com

Branch Office:
9212 E 37th Street North
Wichita, KS 67226
316-315-0044
316-315-0660 (fax)
866-211-5439
ronb@generalparts.com

KENTUCKY (KY)

All ZIP Codes

Service Solutions Group

Main office:
127 Dishman Lane
Bowling Green, KY 42101
270-783-0012
270-783-0058
don.roenigk@servicesg.com

Branch office:
1051 Goodwin Dr.
Lexington, KY 40505
859-254-8854
859-231-7781 (fax)
800-432-9269
cassie.walker@servicesg.com

Branch office:
4283 Produce Road
Louisville, KY 40218
502-964-7007
502-964-7202 (fax)
800-637-6350
don.roenigk@servicesg.com

LOUISIANA (LA)

All ZIP Codes

Heritage Service Group of New Orleans
1532 River Oaks Rd.
West Harahan, LA 70123
800-983-9027
504-733-2559 (fax)
fredh@hfse.com

MAINE (ME)

All ZIP Codes

Pine Tree Food Equipment Inc.

Main office:
175 Lewiston Road
Gray, ME 04039
207-657-6400
207-657-5464 (fax)
800-540-5427 (in Maine)
dan@pinetreefoodequipment.com

Branch office:
6 State Street
Brewer, ME 04412
207-989-4862
800-540-5427
info@pinetreefoodequipment.com

MARYLAND (MD)

All ZIP Codes

Electric Motor Repair

Main office:
9100 Yellow Brick Road Suite H
Rosedale, MD 21237
410-467-8080
410-467-4191 (parts fax)
410-243-2509 (service fax)
410-467-2512 (corp. fax)
800-879-4994 (24 hour)
emr@emrco.com

Branch office:
5316 Sunnyside Ave.
Beltsville, MD 20705
301-931-7000
301-931-3060 (fax)
800-348-2365
rlee@emrco.com

Branch office:
805 N. Salisbury Blvd.
Salisbury, MD 21801
410-543-8080
410-548-4038
877-753-8080
dcheeser@emrco.com

MASSACHUSETTS (MA)

ZIP Codes 01000-01399

Authorized Appliance

Main office: 74 River Street
Rutland, VT 05701
802-775-5588
802-775-9593 (fax)
800-874-1080
bborger@together.net

BETTCHER Industries, Inc.
FOODSERVICE GROUP



SERVICE PROVIDERS (CONTINUED)



NORTH AMERICA AUTHORIZED SERVICE AGENCY LISTING, Bettcher Industries, Inc. Foodservice Equipment, Page 4

Midwest@mfeservice.com

ZIP Codes 49800-49999

Branch office:
109B Loomis St
Manchester, CT 06040
860-649-2355
860-646-8926 (fax)
aasc1@together.net
ZIP Codes 01400-02799

Ace Service Company

Main office:
95 Hampton Avenue
Needham, MA 02494
781-449-4220
781-444-4789 (fax)
800-225-4510
service@aceserviceco.com

Branch office:
500 Harvey Rd.
Manchester, NH 03103
603-668-5070
603-626-6067 (fax)
800-225-2510
service@aceserviceco.com

MICHIGAN (MI)

ZIP Codes 48000-48799

A&R Repairs/Bakers Kneads
26352 Lawrence
Centerline, MI 48015
586-758-4440
586-758-0740 (fax)
800-852-2261
gary@arrepairs

ZIP Codes 48800-49799

Midwest Food Equipment Service Inc.

Main office:
3055 Dixie Avenue
Grandville, MI 49418
616-261-2000
616-261-2020 (fax)
800-288-7060
Midwest@mfeservice.com

Branch office:
3310 Redmond
Kalamazoo, MI 49001
616-372-1012
616-372-1054 (fax)
800-288-7050

General Parts
W223 N735 Saratoga Drive
Waukesha, WI 53186
262-650-6666
262-650-6660 (fax)
800-279-9976
800-279-9978 (fax)
jeanh@generalparts.com

MINNESOTA (MN)

All ZIP Codes

General Parts

Main office:
11311 Hampshire Ave. South
Bloomington, MN 55438
952-944-5800
952-944-7101
800-279-9980
guyj@generalparts.com

Branch office:
10 South 18th Street
Fargo, ND 58103
701-235-4161
701-235-0539 (fax)
800-279-9965 (fax)
800-279-9987
gregp@generalparts.com

MISSISSIPPI (MS)

All ZIP Codes

Heritage Service Group of Mississippi
800-983-9027
866-278-8661 (fax)
fredh@hfse.com

MISSOURI (MO)

ZIP Codes 63800-63899

Heritage Service Group of Florida
800-983-9027
800-800-4981 (fax)
fredh@hfse.com

ZIP Codes 63000-63799, 63900-63999, 65000-65299, 65400-65599

Commercial Kitchen Services, Inc.
10667 Midwest Industrial Blvd.
Saint Louis, MO 63132
314-890-0700
314-890-0705 (fax)
800-966-2936
info@cks-stl.com

ZIP Codes 64000-64899, 65300-65399, 65600-65899

General Parts

Main office:
1101 E 13th Street
Kansas City, MO 64106
816-421-5400
816-421-1270 (fax)
800-279-9968 (fax)
800-279-9967
stever@generalparts.com

MONTANA (MT)

All ZIP Codes

Custom Commercial Service
Main office:
1817 East Main
Laurel, MT 59044
406-628-2262
406-628-2264 (fax)
800-736-5357
ccsmt@aol.com

Branch office:
Mailing Address: P.O. Box 2066
E Helena, MT 59635
Shipping address:
101 W. Main
E. Helena, MT 59635
406-443-1333
406-443-1222 (fax)
866-443-1333
ccsmt@aol.com

Branch office:
8280 Hwy 200 East
Milltown, MT 58851
406-829-8288
406-829-8290 (fax)



SERVICE PROVIDERS (CONTINUED)



NORTH AMERICA AUTHORIZED SERVICE AGENCY LISTING, Bettcher Foodservice Equipment, Page 5

ccsmt@aol.com

NEBRASKA (NE)

All ZIP Codes

General Parts
4423 South 134th Street
Omaha, NE 68137
402-408-9990
402-408-9991 (fax)
888-831-4031
lorrym@generalparts.com

NEVADA (NV)

All ZIP Codes

Burney's Commercial Service
Main office: 4480 Aldebaran Avenue
Las Vegas, NV 89103
702-736-0006
702-798-7531 (fax)
burneyscomm@aol.com

Branch office:
1528 Linda Way
Sparks, NV 89431
775-355-9111
775-355-9128 (fax)
800-240-9111
burneysparks@sbcglobal.net

NEW HAMPSHIRE (NH)

All ZIP Codes

Authorized Appliance
Main office:
74 River Street
Rutland, VT 05701
802-775-5588
802-775-9593 (fax)
800-874-1080
bborger@together.net

NEW JERSEY (NJ)

ZIP Codes 08000-08799

Electric Motor Repair
3494 Progress Dr., Unit F
Bensalem, PA 19020
215-604-1260
215-604-1306 (fax)
888-467-8080
ssandlass@emrco.com

ZIP Codes 07000-07999, 08800-08999

Jay Hill Repairs
90 Clinton Road
Fairfield, NJ 07004
973-575-9145
908-780-1411
973-575-5890 (fax)
800-836-0643
888-529-4455
dvazzano@jayhillrepairs.com

NEW MEXICO (NM)

All ZIP Codes

R&B Commercial Service, Inc.
4412 Towner NE
Albuquerque, NM 87110

PO Box 36378
Albuquerque, NM 87176
505-889-4090
505-889-3845 (fax)
800-376-1821
barryd@rbcommserv.com

NEW YORK (NY)

ZIP Codes 10000-11999

ALPRO Service Company
1127 Willoughby Avenue
Brooklyn, NY 11237
718-386-2515
718-417-6380
info@alproservice.com

ZIP Codes 12000-14999

Duffy's Equipment Service

Main office:
3138 Oneida Street
Sauquoit, NY 13456
800-836-1014
315-737-7132 (fax)
info@duffysequipmentservice.com

Branch office:
1310 Clinton Street
Buffalo, NY 14206
800-836-1014
716-824-9442 (fax)
buffmanager@duffysequipment.com

Branch office:
1904 E. Main Street
Endicott, NY 13760
800-836-1014
607-754-3343 (fax)
bingmanager@duffysequipment.com

Branch office:
109 Albion Ave.
Liverpool, NY 13088
800-836-1014
315-428-8715 (fax)
syrmanager@duffysequipment.com

Branch office:
140 Child Street
Rochester, NY 14611
800-836-1014
585-328-2627 (fax)
rochmanager@duffysequipment.com

Branch office:
305 State Street
Watertown, NY 13601
800-836-1014
315-778-5058 (fax)
wtmanager@duffysequipment.com

NORTH CAROLINA (NC)

All ZIP Codes

Whaley Food Service

Main office:
8334-K Arrowridge Blvd.
Charlotte, NC 28273
704-529-6242
704-529-1558 (fax)
woody.adkins@whaleyfoodservice.com

Branch office:
3630 Cessna Dr.
Garner, NC 27529
919-779-2266
919-779-2224 (fax)
terry.humphries@whaleyfoodservice.com

Branch office:
3020B Thurston Avenue
Greensboro, NC 27406
336-333-2333





SERVICE PROVIDERS (CONTINUED)



NORTH AMERICA AUTHORIZED SERVICE AGENCY LISTING, Bettcher Industries, Inc. Foodservice Equipment, Page 6

336-808-4917 (fax)
Dan.sampson@whaleyfoodservice.com
Branch office:
6418-101 Amsterdam Way
Wilmington, NC 28405
910-791-0000
910-332-0080 (fax)
Ken.spencer@whaleyfoodservice.com

NORTH DAKOTA (ND)

All ZIP Codes

General Parts
10 South 18th Street
Fargo, ND 58103
701-235-4161
701-235-0539 (fax)
800-279-9965 (fax)
800-279-9987
gregp@generalparts.com

OHIO (OH)

ZIP Codes 43000-43399, 43700-43899, 45000-45799

Service Solutions Group

Main office:
890 Redna Terrace
Cincinnati, OH 45215
513-772-6600
513-612-6600 (fax)
800-543-2060
don.horman@servicesg.com

Branch office:
6025 N. Dixie Dr.
Dayton, OH 45414
937-898-4040
937-898-4177 (fax)
800-257-2611
don.horman@servicesg.com

ZIP Codes 43400-43699, 45800-45899

The Wichman Company
7 North Westwood Avenue
Toledo, OH 43607
419-385-9121
419-385-0202 (fax)
wichmanservice@bex.net

ZIP Codes 43900-44799

Appliance Installation Service
5265 Naiman Parkway
Suite I
Cleveland, OH 44139
440-248-1489
800-428-8448
440-248-1543 (fax)
wevans@ais-service.net

Appliance Installation Service
590 East Western Reserve Road
Youngstown, OH 44514
330-729-9705
877-346-6544
330-729-9707 (fax)
ytownsvc@ais-service.net

OKLAHOMA (OK)

All ZIP Codes

Hagar Restaurant Service
1229 West Main Street
Oklahoma City, OK 73106
405-235-2184
405-236-5592 (fax)
800-445-1791
bhagar@hagarrs.com

Hagar Restaurant Service
5932 S Kelly Drive
Tulsa, OK 74135
918-664-4665
918-664-1618 (fax)
800-722-0229
lcarlson@hagarrs.com

OREGON (OR)

All ZIP Codes

Ron's Service
Main office:
16364 Southwest 72nd Ave.
Portland, OR 97224
503-624-0890
503-684-6107 (fax)
800-851-4118
info@ronsservice.com

Branch office:
201 Bateman Dr., Suite 8
Central Point, OR 97502
541-665-0410
541-665-0411 (fax)

info@ronsservice.com

PENNSYLVANIA (PA)

ZIP Codes 18900-19499

Electric Motor Repair
Main office:
3494 Progress Dr., Unit F
Bensalem, PA 19020
215-604-1260
215-604-1306 (fax)
888-467-8080
ssandlass@emrco.com

ZIP Codes 15000-16799

Appliance Installation Service
1911 West 26th Street
Erie, PA 16508
412-809-0244
800-726-6020
412-809-0246 (fax)
rgray@ais-dervice.net

Appliance Installation Service
740 Vista Park Drive
Pittsburgh, PA 15205
412-809-0244
800-726-6020
412-809-0246 (fax)
wevans@ais-service.net

ZIP Codes 16900-18899, 19500-19699

K&D Factory Service
Main office:
1833 North Cameron Street
Harrisburg, PA 17103
717-236-9039
717-238-4367 (fax)
800-932-0503
info@kdfsi.com

Branch office:
480 Business Park Lane
Allentown, PA 18109
610-432-0266
717-238-4367 (fax)
info@kdfsi.com

Branch office:
597 Lehigh Avenue
Lancaster, PA 17602
717-394-4892
717-238-4367 (fax)
info@kdfsi.com

SERVICE PROVIDERS (CONTINUED)

NORTH AMERICA AUTHORIZED SERVICE AGENCY LISTING, Bettcher Industries, Inc. Foodservice Equipment, Page 7

Branch office:
1818 Cedar Avenue
Scranton, PA 18505
570-342-5135
717-238-4367 (fax)
info@kdfsi.com

Branch office:
2670 Euclid Avenue
Williamsport, PA 17702
570-323-8010
717-238-4367 (fax)
info@kdfsi.com

Branch office:
2100 W Market Street
York, PA 17404
717-793-8525
717-238-4367 (fax)
info@kdfsi.com

RHODE ISLAND (RI)

All ZIP Codes

Ace Service Company
95 Hampton Avenue
Needham, MA 02494
781-449-4220
781-444-4789 (fax)
800-225-4510
service@aceserviceco.com

SOUTH CAROLINA (SC)

All ZIP Codes

Whalely Food Service

Main office mailing address:
P.O. Box 615
Lexington, SC 29073

Main office shipping address:
137 Cedar Road Lexington, SC 29071
803-996-9900
803-996-9910 (fax)
800-877-2662
info@whalelyfoodservice.com

Branch office:
748 Congaree Road
Greenville, SC 29607
864-234-7011
864-770-8993- (fax)
don.mason@whalelyfoodservice.com

Branch office:
1406-C Commerce Place
Myrtle Beach, SC 29577
843-626-1866
877-798-8892 (fax)
rand.reeder@whalelyfoodservice.com

Branch office:
4740-A Franchise St.
North Charleston, SC 29418
843-760-2110
843-552-4803 (fax)
David.douglas@whalelyfoodservice.com

SOUTH DAKOTA (SD)

All ZIP Codes

General Parts
10 South 18th Street
Fargo, ND 58103
701-235-4161
701-235-0539 (fax)
800-279-9965 (fax)
800-279-9987
gregp@generalparts.com

TENNESSEE (TN)

ZIP Codes 37500-37599, 38000-38399

Heritage Service Group of Tennessee
800-983-9027
901-379-0935(fax)
fredh@hfse.com

ZIP Codes 37000-37499, 37600-37999, 38400-38599

Whalely Foodservice Repairs
438 Harding Industrial Drive
615-690-1400
615-882-0827(fax)
terry.williams@whalelyfoodservice.com

TEXAS (TX)

ZIP Codes 75000-75799, 76000-76999, 79000-79799

Cooking Equipment Specialist (RSI)
3040 East Meadows
Mesquite (Dallas/Ft Worth), TX 75150
972-279-3800

972-686-9656 (fax)
888-866-9276
jpritchett@rsidfw.com

Hagar Restaurant Service
433 Regal Row
Dallas, TX 75247
214-574-5200
214-574-5211 (fax)
866-919-5200
bgilpatrick@hagarrs.com

ZIP Codes 75800-75999, 77000-77899, 78900-78999

Armstrong Repair Center
5110 Glenmont
Houston, TX 77081
713-666-7100
713-592-5214 (fax)
800-392-5325
rga@armstrongrepair.com

Armstrong Repair Center
2215 Woodward Street
Austin, TX 78744
512-416-1101
512-416-6912 (fax)
800-392-5322
ernestd@armstrongrepair.com

ZIP Codes 77800-78899, 79800-79999

Commercial Kitchen Parts & Service

Main office:
1377 N. Brazos
San Antonio, TX 78207
Mailing address:
PO Box 831128
San Antonio, TX 78283
210-735-2811
210-735-7421 (fax)
brock@ckps.com

Branch office:
2215 Woodward Street
Austin, TX 78757
800-392-5322
512-416-6912 (fax)
david@ckps.com

 **BETTCHER Industries, Inc.**
FOODSERVICE GROUP



SERVICE PROVIDERS (CONTINUED)



NORTH AMERICA AUTHORIZED SERVICE AGENCY LISTING, Bettcher Industries, Inc. Foodservice Equipment, Page 8

Branch office:
1117 Hendricks Street #126
Corpus Christi, TX 78417
800-242-5928
361-882-4903 (fax)
frankr@ckps.com

Branch office:
301 N. McColl Road #D
McAllen, TX 78501
956-664-8267
956-585-0451 (fax)
leo@ckps.com

UTAH (UT)

All ZIP Codes

Lamonica's
6211 South 380 West
Murray, UT 84107
801-263-3221
801-263-3229 (fax)
lamonicas81@aol.com

VERMONT (VT)

All ZIP Codes

Authorized Appliance
Main office:
74 River Street
Rutland, VT 05701
802-775-5588
802-775-9593 (fax)
800-874-1080
bborger@together.net

VIRGINIA (VA)

All ZIP Codes

Daubers Inc.
Main Office:
7645 Dynatech Court
Springfield, VA 22153
703-866-3600
703-866-4071 (fax)
800-554-7788
chuck@daubers.com

Branch Office:
5255 Henneman Drive
Norfolk, VA 23513
757-855-4097
757-855-1795 (fax)
800-880-7775
randy@daubers.com

Branch Office:
2407 Ownby Lane
Richmond, VA 23220
804-359-9065
804-359-4331 (Fax)
800-273-9593
jim@daubers.com

WASHINGTON (WA)

ZIP Codes 98000-98599, 98700-99499

Restaurant Appliance Service
22322 20th Ave SE
Bothell, WA 98011-8418
206-524-8200
425-486-8544 (fax)
866-770-2022
tom.mcpeters@3wire.com

ZIP Codes 98600-98699

Ron's Service

Main office:
16364 Southwest 72nd Ave.
Portland, OR 97224
503-624-0890
503-684-6107 (fax)
800-851-4118
info@ronsservice.com

WEST VIRGINIA (WV)

All ZIP Codes
Heritage Service Group West Virginia
800-983-9027
800-800-4981 (fax)
fredh@hfse.com

WISCONSIN (WI)

All ZIP Codes

General Parts
W223 N735 Saratoga Drive
Waukesha, WI 53186
262-650-6666
262-650-6660 (fax)
800-279-9976
800-279-9978 (fax)

jeanh@general.com

WYOMING (WY)

All ZIP Codes

Custom Commercial Service
2009 Robertson #13
Worland, WY 82401
888-567-8199
877-291-9761 (fax)
ccsmt@aol.com



6801 State Route 60, Birmingham, OH 44816
Phone (440) 965-4422 Fax (440) 965-4900
www.bettcher.com

GPM-19.04/001 REV. I