



# MODEL 44TL POWER MEAT CUTTER

## OPERATING AND SERVICE MANUAL

### TRUE LEFT OPERATION



REVISED – Applicable to Model 44 Starting with Serial No. 3850 Except as Noted

### **\* IMPORTANT NOTICE \***

This Manual contains important safety instructions which must be strictly followed when using this equipment.

PTCT Md 44TL  
368-8-13-2

# OPERATING AND SERVICE MANUAL FOR BIRO MODEL 44

## WARNING TO ALL PURCHASERS, OPERATORS AND OPERATION SUPERVISORS:

**FAILURE TO READ AND ADHERE TO THE FOLLOWING IMPORTANT INSTRUCTIONS COULD RESULT IN BODILY INJURY.**

- (1) Do not electric wire this power cutter. Have only a qualified and certified electrician wire this power cutter as required. Be sure machine is grounded. Failure to ground this machine could result in electric shock.
- (2) Do not place machine on sloping floor. Always place machine on flat non-skid floor.
- (3) Do not use this power cutter for non-food products.
- (4) Do not use this power cutter to cut pigs feet.
- (5) Do not attempt to operate this power cutter until this machine has been inspected and demonstrated by the seller — recognized BIRO Representative.
- (6) Do not attempt to operate this power cutter unless you or the operator has been properly trained. Improper use or operation of this power cutter could result in bodily injury.
- (7) Do not leave power cutter in operation — unattended.
- (8) Do not tamper, bypass, remove fixed guards, safety interlock electrical switches or any other safety device.
- (9) Do not at any time force feed product through this power cutter.
- (10) Do not alter or modify this power cutter in any way from its original form. This power cutter in its original form meets the intent of O.S.H.A. applicable standards.
- (11) Always use safety pusher plate supplied with each power cutter when cutting small product.
- (12) Do not touch moving blade or moving parts. Never place hand or arm between blade and head column structure.
- (13) Always disconnect power supply before removing shrouds, removable guards, covers, doors, fences, panels for servicing, cleaning or any other reason.
- (14) Use only BIRO parts and accessories properly installed, contact your nearest service agency or The BIRO Manufacturing Company for authorized referral assistance.
- (15) Power cutter operating manuals as supplied with this power cutter are available from BIRO.

**FAILURE TO COMPLY WITH THIS WARNING NOTICE COULD RESULT IN BODILY INJURY.**

**THE BIRO MANUFACTURING COMPANY, 1114 WEST MAIN STREET, MARBLEHEAD, OHIO  
43440-2099 U.S.A. — PHONE (419) 798-4451 — TELEX NO. 241-003**

## TO ASSEMBLE AND SET UP CUTTER FOR USE:

- (1) After placing cutter in operational area, it is imperative that three of the four adjustable foot studs be tightened, using the fourth leg for adjustment to level the cutter.
- (2) To assemble meat gauge plate, Assembly item No. A18275, Page 5, to machine loosen the wing nut on right side of meat gauge bracket, Item No. 272-6-S. Raise the right side of the meat gauge bar, Item 18272, and slip the meat gauge plate over the bar, lower bar back to its original position, tighten wing nut. Keep bar well oiled with food machine oil to insure free movement.
- (3) The stainless steel head, Item No. S18005 comes detached from the base. Slip the head into the Gib, Item No. 18260, (slide gibs) section of the base, See Page 5. Make sure the Gibs, Item No. 18260, (slide gibs) are oiled or greased to insure free movement.

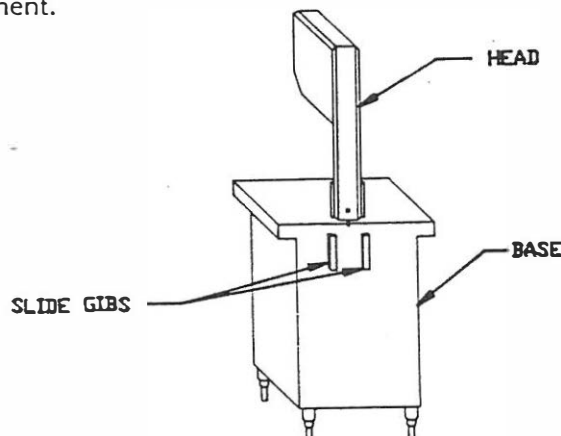

(4) Place upper saw guide removable unit assembly on saw guide bar, Item No. 116-27, and fasten in place with finger lift fastener knob, Item No. 211A-291Q.

(5) Placing blade on cutter: Lift up nylon filler, Item No. 177, Page 4. Hang blade on upper wheel and hold blade on wheel with left hand. With the right hand force the back of the blade between the two steel saw cleaners, Item No. 131, located below the nylon filler, Item No. 177. Lower the nylon filler, Item No. 177, and insert back of blade in upper saw guide slot, Item No. 602. The blade has already dropped over the lower wheel and is ready for tightening. Press down on ratchet handle, Item No. 18010, to tighten. Turn wheel one turn to insure proper tracking and tighten to proper tension. When the tension gauge, Item No. 18197, located at the bottom of the head becomes tight laterally the blade is at its proper tension, Page 5.

(6) The stationary platter, Item No. A18163, is placed on top of the base and held in place with two push pull platter rods, Item No. 18212W, located on the rear rim of the cutter.

(7) The sliding meat carriage table, Item No. 18155, is removed by turning movable stop, Item No. 16200, clockwise. After the carriage is in the channel for operation turn movable stop, counter-clockwise, Page 4.

#### WIRING MOTOR:

(1) Interchange of current is made in motor outlet box. Leads are properly marked. Changing instructions are on motor plate or motor outlet box.

(2) All cutters are wired 220 volts unless otherwise specified. Be sure motor specifications (voltage, cycle, phase) match power supply line. Be sure line voltage is up to specification.

(3) Connect leads to machine in a manner that will be approved by local electrical inspectors.

(4) We recommend not less than No. 12 wire. If leads are too light machine may not have sufficient cutting power and/or speed.

(5) The V-Belt is packed loose in machine to prevent deformation, and must be installed of pulleys at time of wiring motor.

(6) The BiRO Manufacturing Company is not responsible for permanent wiring, connection or installations.

#### LUBRICATION:

**Table Bearings:** grease packed at the factory. Repack as necessary.

**Meat Gauge Gear Rack:** oil daily with food machine oil.

**Slide Gibs:** for mounting head are provided with grease fittings and should be greased every four months.

**Main Bearings:** grease packed at factory. Check and grease if necessary.

#### ADJUSTMENTS:

(1) For tightening motor v-belt: The motor drive belt can be tightened to any desired tension by removal of shims under motor. Recommend approximately 1/2" total flex at center of span.

(2) Saw Guides: Should be adjusted so the guide is 1/32" from the back edge of the blade when the machine is idling. This prolongs the life of the saw wheels by reducing pressure and wear of the saw blade against the flange of the wheel.

#### RECOMMENDED SAFE OPERATING PROCEDURES:

(1) Before starting saw, adjust the Saw Guide Bar down to within 1/2" of product to be cut.

(2) The 256P Safety End Cut Pusher Plate supplied with every machine as standard equipment, should be used when cutting end cuts of meat.

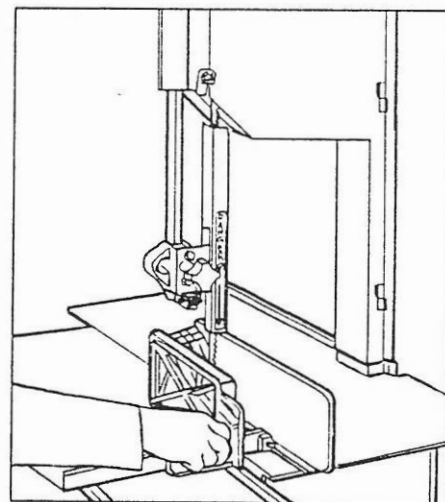
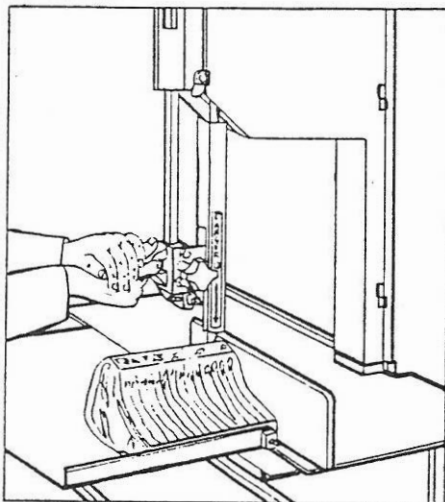

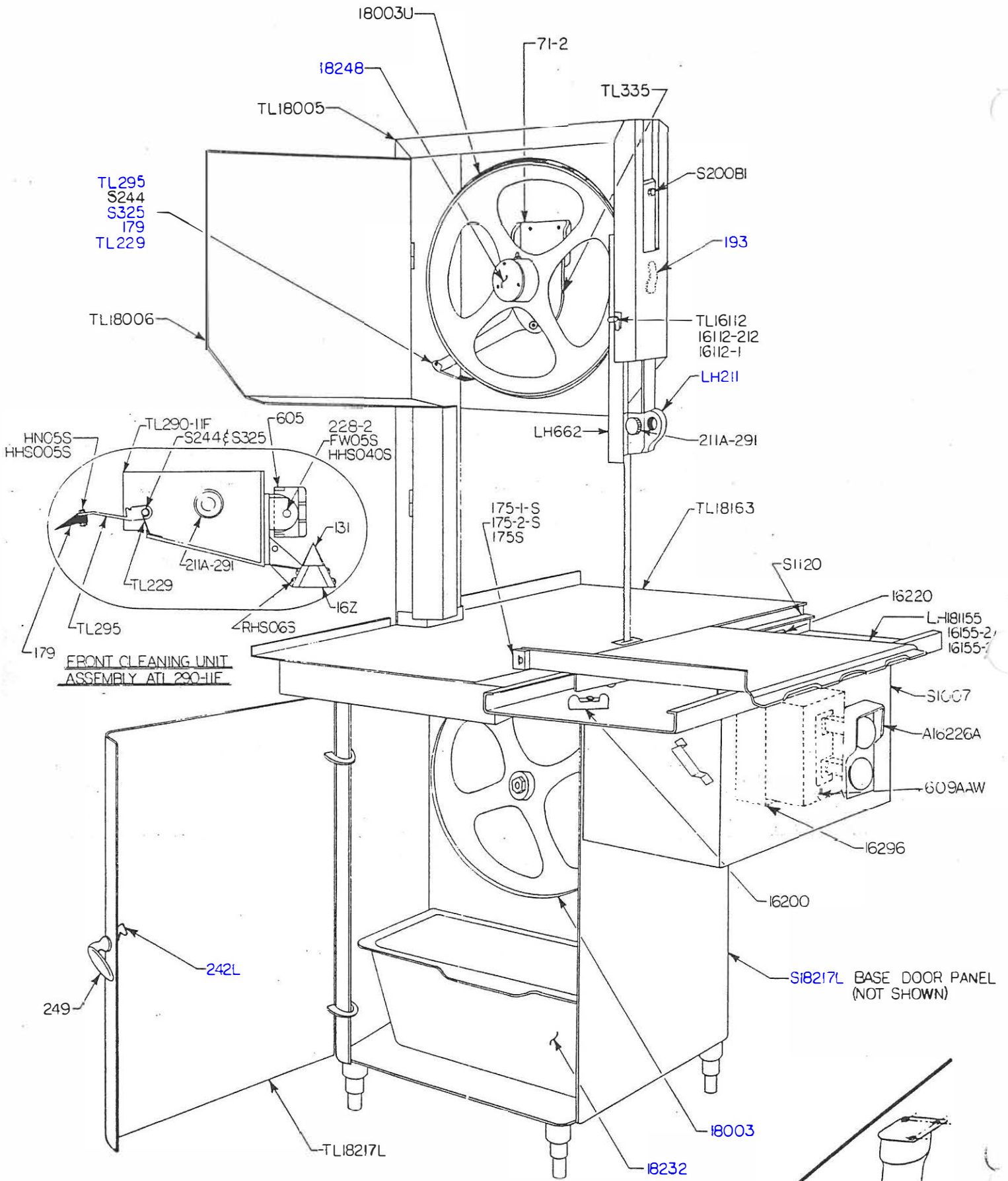

AS239-B30-B  
 Bolt on Base Foot  
 with Fasteners can be  
 Used to Avoid the need  
 for Welding Replacement

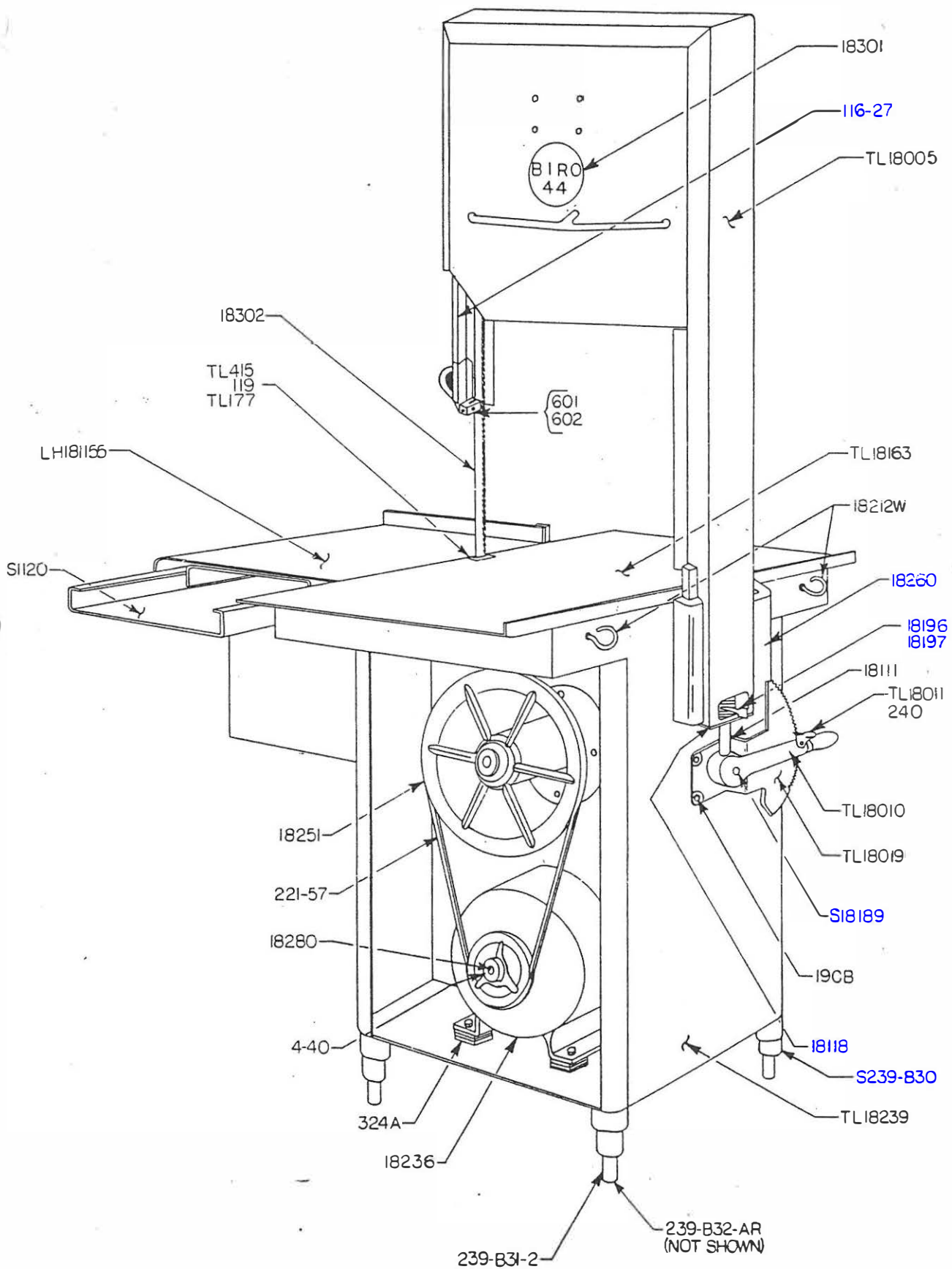

# AS18006 S.S. HEAD & DOOR ASSEMBLY

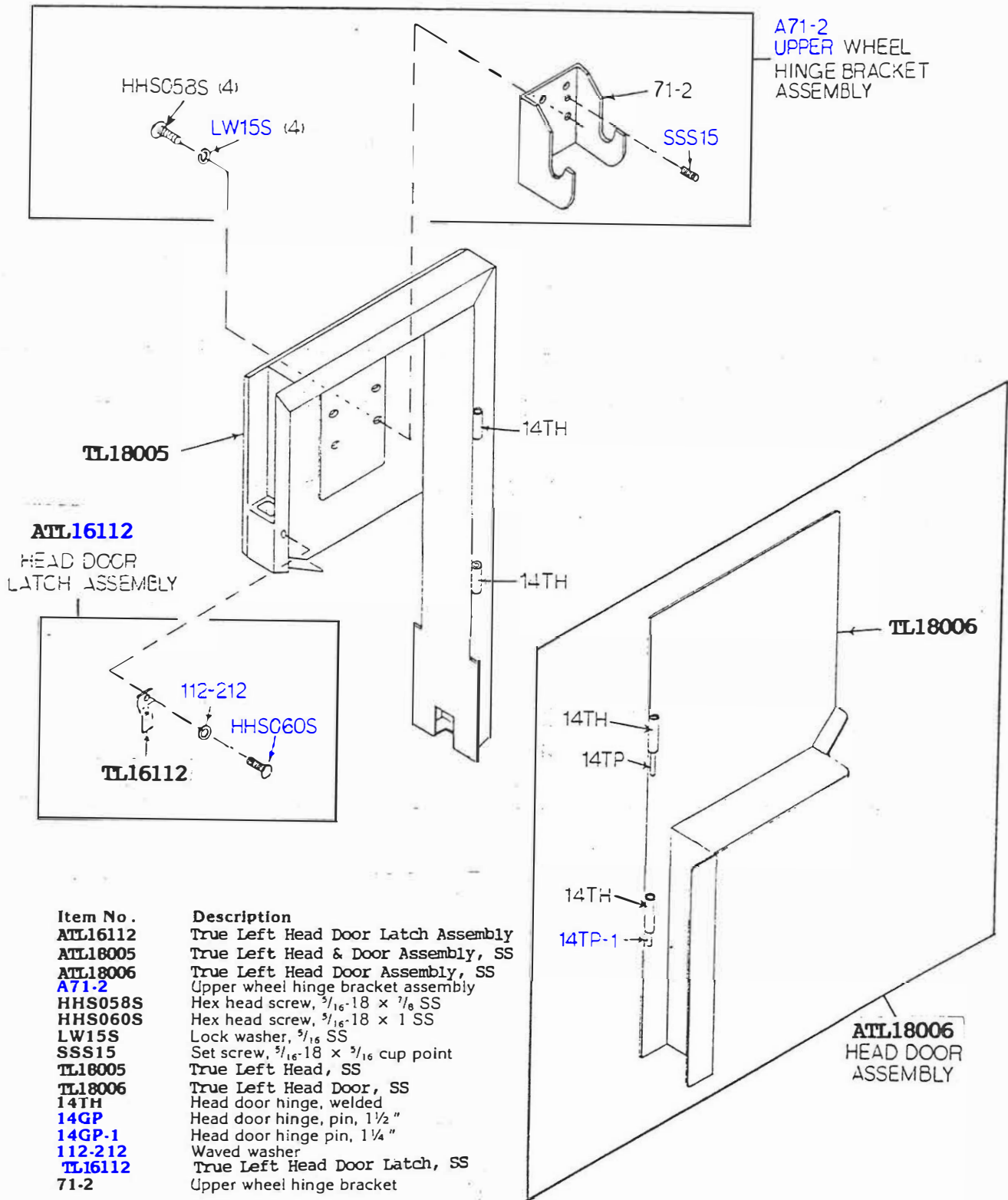

**A71-2**  
UPPER WHEEL  
HINGE BRACKET  
ASSEMBLY

**ATL16112**  
HEAD DOOR  
LATCH ASSEMBLY

**ATL18006**  
HEAD DOOR  
ASSEMBLY

Item No.	Description
ATL16112	True Left Head Door Latch Assembly
ATL18005	True Left Head & Door Assembly, SS
ATL18006	True Left Head Door Assembly, SS
A71-2	Upper wheel hinge bracket assembly
HHS058S	Hex head screw, $\frac{3}{16}$ -18 x $\frac{1}{8}$ SS
HHS060S	Hex head screw, $\frac{3}{16}$ -18 x 1 SS
LW15S	Lock washer, $\frac{3}{16}$ SS
SSS15	Set screw, $\frac{3}{16}$ -18 x $\frac{3}{16}$ cup point
TL18005	True Left Head, SS
TL18006	True Left Head Door, SS
14TH	Head door hinge, welded
14GP	Head door hinge, pin, 1 1/2"
14GP-1	Head door hinge pin, 1 1/4"
112-212	Waved washer
TL16112	True Left Head Door Latch, SS
71-2	Upper wheel hinge bracket

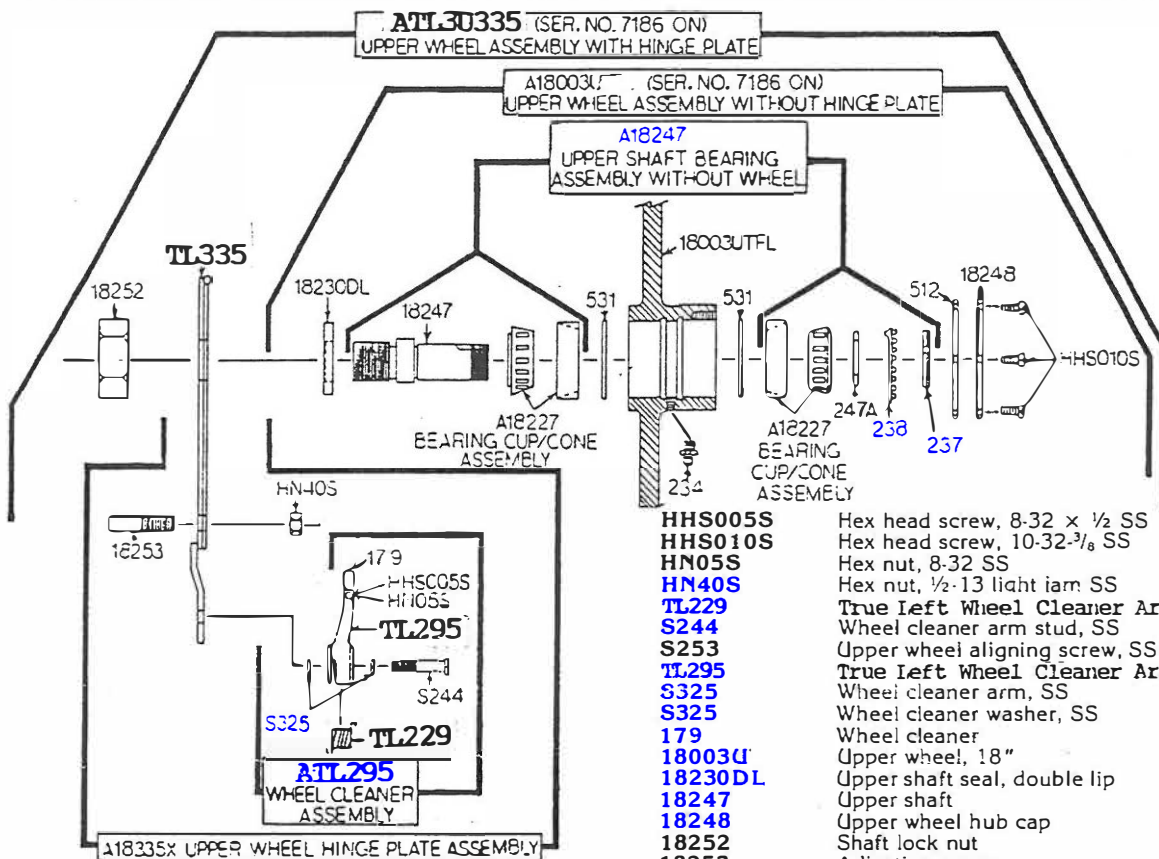

- |                   |                                      |
|-------------------|--------------------------------------|
| <b>A18003UTFL</b> | Upper wheel assembly w/o hinge plate |
| <b>ATL30335</b>   | True Left Up Wheel Assembly W/Hinge  |
| <b>A18227</b>     | Bearing cup/cone assembly            |
| <b>A18247</b>     | Upper shaft bearing assembly         |
| <b>TL335</b>      | True Left Upper Wheel Hinge Plate    |
| <b>ATL295</b>     | True Left Wheel Cleaner Assembly     |

- |                |                                     |
|----------------|-------------------------------------|
| <b>HHS005S</b> | Hex head screw, 8-32 x 1/2 SS       |
| <b>HHS010S</b> | Hex head screw, 10-32-3/8 SS        |
| <b>HN05S</b>   | Hex nut, 8-32 SS                    |
| <b>HN40S</b>   | Hex nut, 1/2-13 light iam SS        |
| <b>TL229</b>   | True Left Wheel Cleaner Arm Spring  |
| <b>S244</b>    | Wheel cleaner arm stud, SS          |
| <b>S253</b>    | Upper wheel aligning screw, SS      |
| <b>TL295</b>   | True Left Wheel Cleaner Arm         |
| <b>S325</b>    | Wheel cleaner arm, SS               |
| <b>S325</b>    | Wheel cleaner washer, SS            |
| <b>179</b>     | Wheel cleaner                       |
| <b>18003U</b>  | Upper wheel, 18"                    |
| <b>18230DL</b> | Upper shaft seal, double lip        |
| <b>18247</b>   | Upper shaft                         |
| <b>18248</b>   | Upper wheel hub cap                 |
| <b>18252</b>   | Shaft lock nut                      |
| <b>18253</b>   | Adjusting screw                     |
| <b>TL335</b>   | True Left Upper Wheel Hinge Plate   |
| <b>234</b>     | Grease fitting                      |
| <b>237</b>     | Upper shaft castellated lock nut    |
| <b>238</b>     | Upper shaft castellated lock washer |
| <b>247A</b>    | Upper shaft bearing back-up washer  |
| <b>512</b>     | Upper wheel hub gasket              |
| <b>531</b>     | Retaining ring (2 req.)             |

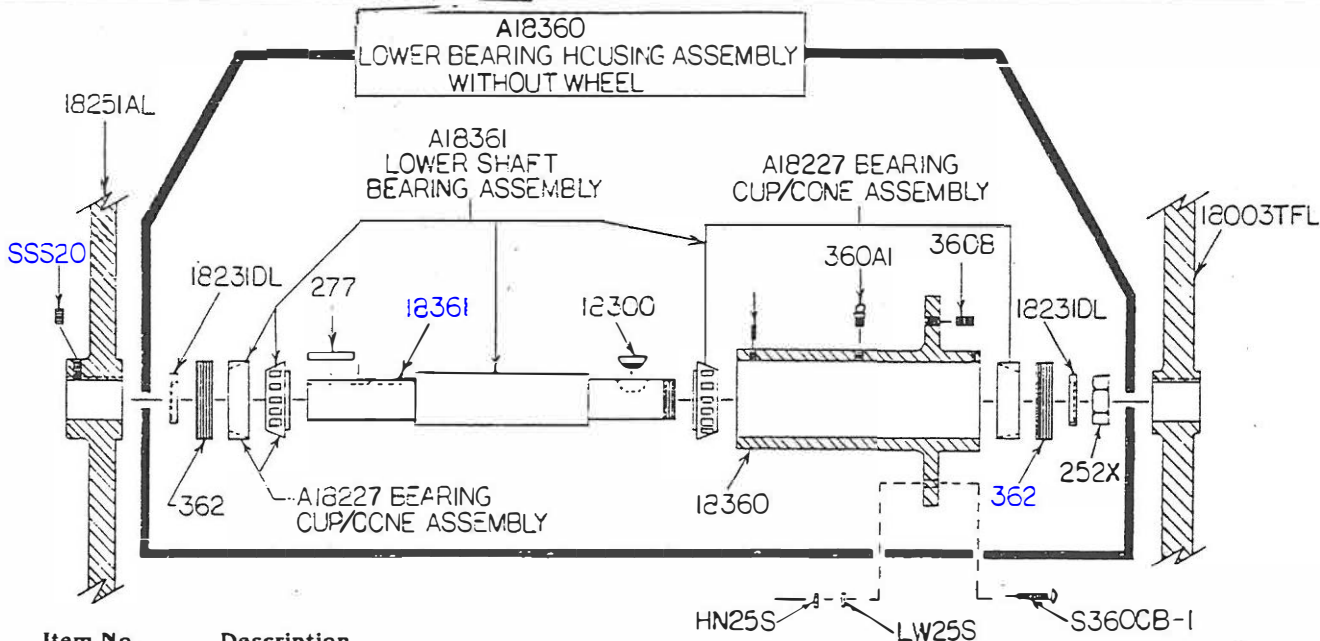

- | Item No.        | Description                          |
|-----------------|--------------------------------------|
| <b>A18227</b>   | Bearing cup/cone assembly            |
| <b>A18361</b>   | Lower shaft bearing assembly         |
| <b>HN25S</b>    | Hex nut, 3/8-16 SS                   |
| <b>LW25S</b>    | Lock washer, 3/8 SS                  |
| <b>SSS20</b>    | Set screw, 3/8-16 x 3/8 cup point    |
| <b>S360CB-1</b> | Carriage bolt, 3/8-16 x 1 1/4 SS     |
| <b>18003TFL</b> | Lower wheel                          |
| <b>18231DL</b>  | Lower shaft seal, double lip         |
| <b>18251AL</b>  | Upper v-belt pulley, 12.8 x 1 1/8 AL |

- |              |                                    |
|--------------|------------------------------------|
| <b>18300</b> | Lower shaft woodruff key           |
| <b>18360</b> | Lower bearing housing              |
| <b>18361</b> | Lower shaft                        |
| <b>252X</b>  | Lower shaft nut                    |
| <b>277</b>   | Lower pulley key                   |
| <b>360A1</b> | Grease fitting                     |
| <b>360B</b>  | Set screw, 3/8-16 x 1/2 flat point |
| <b>362</b>   | Lower bearing housing adj. cap     |

**ATL18019**  
RATCHET ASSEMBLY

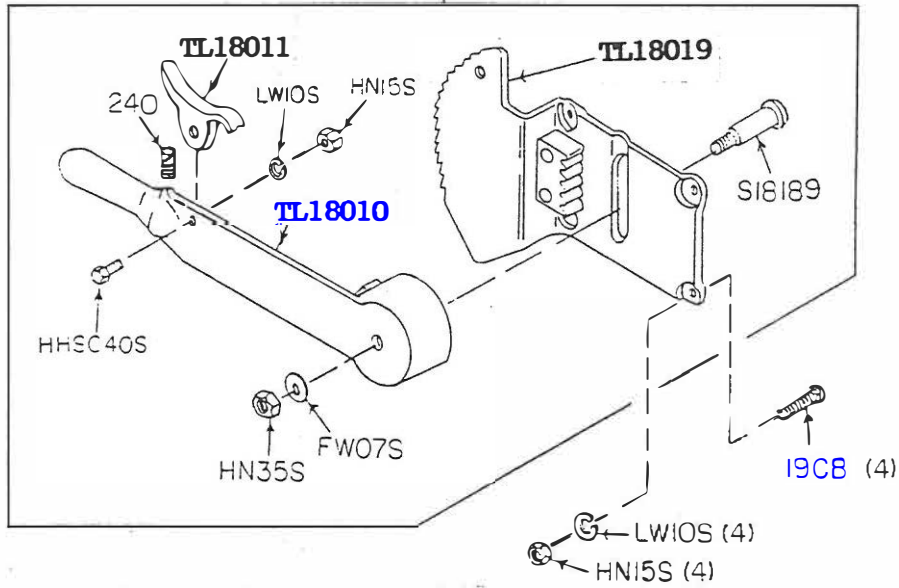

**Item No.**  
ATL18019  
FW07S  
HHS025S  
HN15S  
HN35S  
LW10S

**Description**  
True Left Ratchet Assembly  
Flat washer,  $\frac{3}{8}$  SS  
Hex head screw,  $\frac{1}{4}$ -20 x  $\frac{1}{2}$  SS  
Hex nut,  $\frac{1}{4}$ -20 SS  
Hex nut,  $\frac{3}{8}$ -16 SS  
Lock washer,  $\frac{1}{4}$  SS

TL18011 True Left Ratchet Trigger, SS  
S18189 Ratchet arm stud SS  
TL18010 True Left Ratchet Arm  
TL18019 True Left Ratchet Base  
19CB Carriage bolt  $\frac{1}{4}$ -20 x  $\frac{3}{4}$  SS  
240 Ratchet trigger spring

#ATL290-11F  
CLEANING UNIT  
TOTAL ASSEMBLY

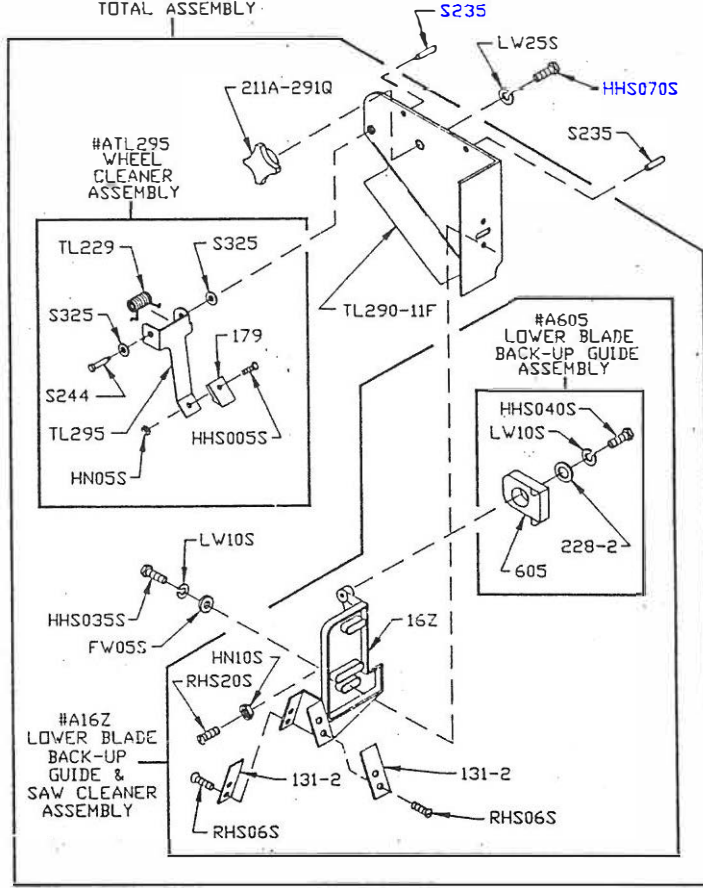

Item No.	Description
A16Z	Guide bracket saw cleaner assembly
<b>ATL295</b>	<b>True Left Wheel Cleaner Assembly</b>
A605	Lower blade back-up guide assembly
<b>ATL290-11F</b>	<b>Cleaning Unit Assembly, Front</b>
FHS20S	Flat head screw, 10-32 x 1/2 SS
FW05S	Flat washer, 1/4 SS
HHS005S	Hex head screw, 8-32 x 1/2 SS
HHS035S	Hex head screw, 1/4-20 x 3/8 SS
HHS040S	Hex head screw, 1/4-20 x 3/4 SS
HHS070S	Hex head screw, 3/8-16 x 1 SS
HN05S	Hex nut, 8-32 SS
HN10S	Hex nut, 10-32 SS
LW10S	Lock washer, 1/4 SS
LW25S	Lock washer, 3/8 SS
RHS06S	Round head screw, 8-32 x 1/4 SS
RHS20S	Round head screw, 10-32 x 1/4 SS
<b>TL229</b>	<b>True Left Wheel Cleaner Arm Spring</b>
S244	Wheel cleaner arm stud SS
<b>TL290-11F</b>	<b>True Left Cleaning Unit Stamping</b>
TL295	True Left Wheel Cleaner Arm
S325	Washer SS
TP4S	Taper pin #4 x 1 1/2 SS
131	Saw cleaner SS
16Z	Lower guide bracket saw cleaner holder
179	Wheel cleaner
211A-291Q	Fastener knob, 4 point
228-2	Lower guide washer
290-8	Cleaning unit locator washer SS
605	Saw guide lower blade back-up

**ALH116-27**  
SAW GUIDE  
BAR  
ASSEMBLY

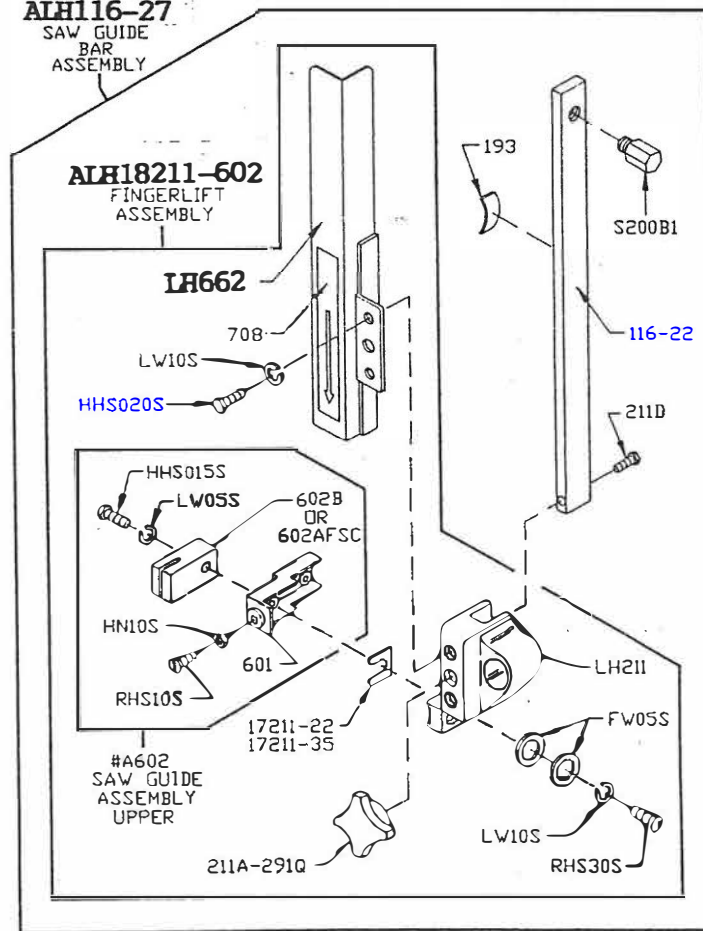

Item No.	Description
<b>ALH116-27</b>	<b>Left Hand Saw Guide Bar Assembly</b>
<b>ALH18211-602</b>	<b>Left Hand Finger Lift Assembly</b>
A602	Saw guide assembly, upper
FW05S	Flat washer, 1/4 SS
HHS015S	Hex head screw, 10-32 x 7/8 SS
HHS020S	Hex head screw, 1/4-20 x 3/8 SS
HN10S	Hex nut, 10-32 SS
<b>LH662</b>	<b>Saw guard for true left head</b>
LW05S	Lock washer, #10 SS
LW10S	Lock washer, 1/4 SS
RHS10S	Round head screw, 10-32 x 3/4 SS
RHS30S	Round head screw, 1/4-20 x 7/8 SS
S200B1	Stop stud on guide bar
116-27	Saw guide bar, 27"
<b>LH662</b>	<b>Left Hand Saw Guard</b>
17211-22	Finger lift, shim, .022
17211-35	Finger lift shim .035
193	Saw guide bar spring
<b>LH211</b>	<b>Left Hand Finger Lift</b>
211A-291Q	Fastener knob, 4 point
211D	Finger lift fastener bolt
601	Upper saw guide bracket
602A	Upper saw guide with carbide
602AFSC	Upper saw guide, narrow fish
708	Decal "DANGER EXPOSED BLADE"

**ATL415**  
STATIONARY BAR ASSEMBLY

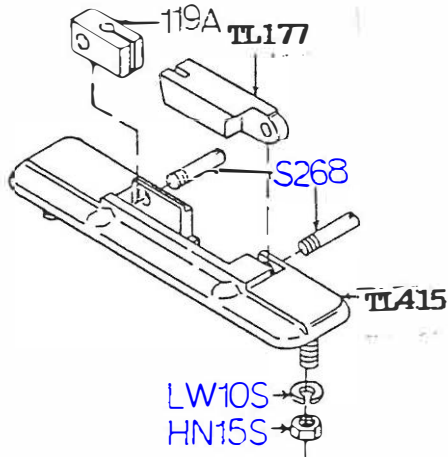

Item No.	Description
<b>ATL415</b>	True Left Sta. Bar Assembly, SS
<b>HN15S</b>	Hex nut, 1/4-20 SS
<b>LW10S</b>	Lock washer, 1/4 SS
<b>S268</b>	Stationary bar headless screw
<b>TL415</b>	True Left Stationary Bar, SS
<b>119A</b>	Saw guide in stationary bar
<b>TL177</b>	True Left Nylon Filler

**A16132**  
REAR STEEL CLEANER ASSEMBLY

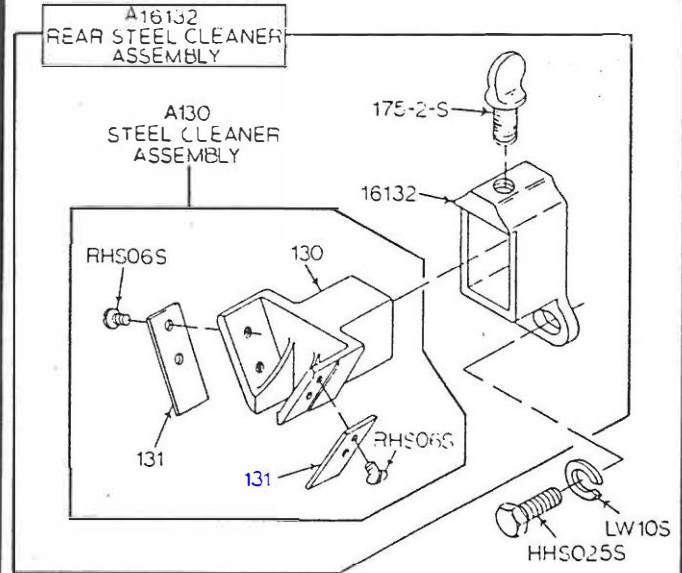

Item No.	Description
<b>A130</b>	Saw cleaner assembly
<b>A16132</b>	Steel cleaner assembly, rear
<b>HHS025S</b>	Hex head screw, 1/4-20 x 1/2 SS
<b>LW10S</b>	Lock washer, 1/4 SS
<b>RHS06S</b>	Round head screw, 8-32 x 1/4 SS
<b>130</b>	Saw cleaner bracket rear
<b>131</b>	Saw cleaner SS
<b>16132</b>	Saw cleaner bracket holder, rear
<b>175-2-S</b>	Thumb screw, 1/4-20 x 1/2

**A18196**  
TENSION SPRING ASSEMBLY

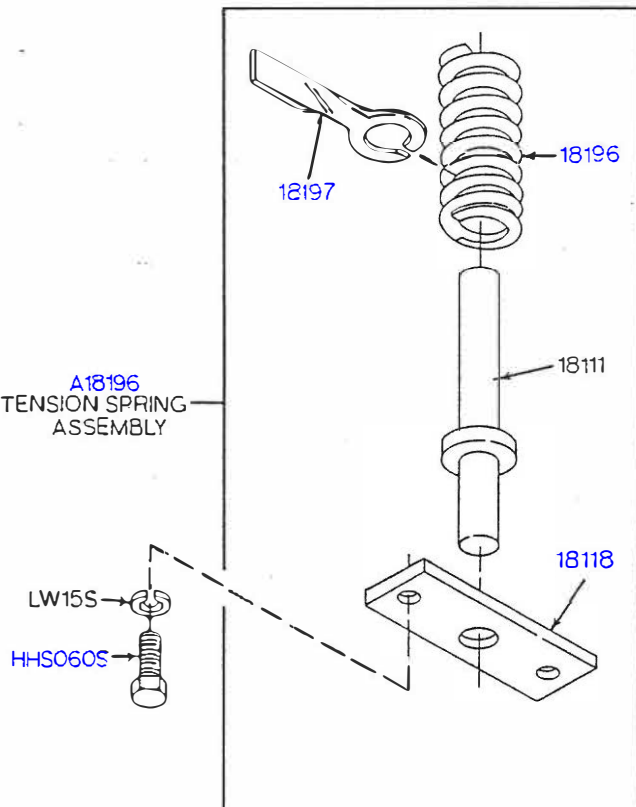

Item No.	Description
<b>A18196</b>	Tension spring assembly
<b>HHS060S</b>	Hex head screw, 5/16-18 x 1 SS
<b>LW15S</b>	Lock washer, 3/16 SS
<b>18111</b>	Tension spring pin
<b>18118</b>	Tension spring plate
<b>18197</b>	Tension spring gauge
<b>18196</b>	Saw tension spring

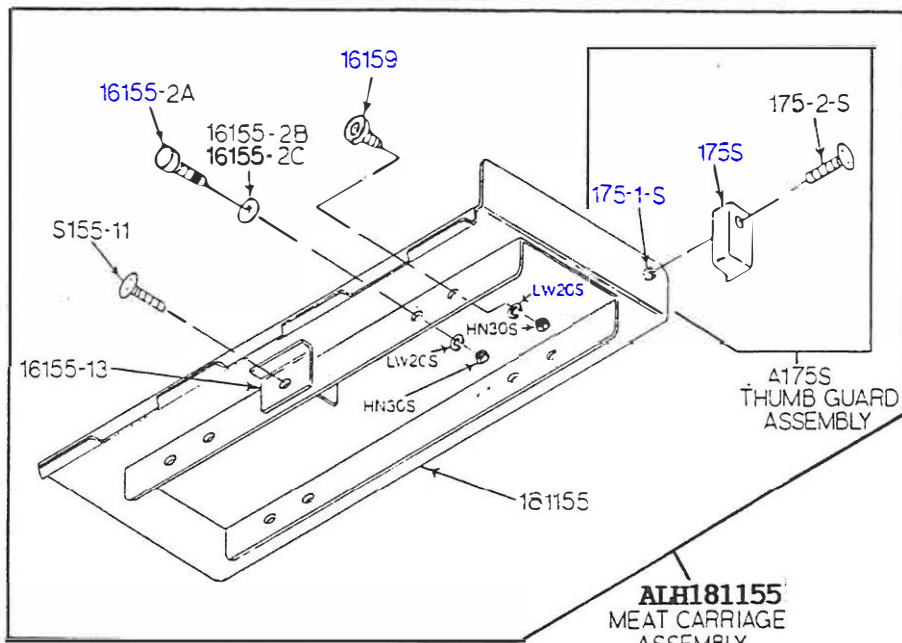

Item No.  
**ALH181155**  
**A175S**  
**HN30S**  
**LW20S**  
**S155-11**  
**16155-2A**  
**16155-2B**  
**16155-2C**

**Description**  
**Left Hand Meat Carriage Assembly**  
 Thumb guard assembly  
 Hex nut, 3/8-16 light jam SS  
 Lock washer 3/8 light SS  
 Meat carriage stop thumb screw  
 Meat carriage guide  
 Meat carriage guide spacer, 1/64TK

**16155-2C**  
**16155-13**  
**16159**  
**175S**  
**175-1-S**  
**175-2-S**  
**ALH181155**

Meat carriage guide spacer, 1/32TK  
 Carriage stop angle SS, welded  
 Meat carriage bearing SS  
 Thumb guard, nylon  
 Thumb guard nut SS  
 Thumb screw 1/4-20 x 1/2  
**Left Hand Meat Carriage Assembly**

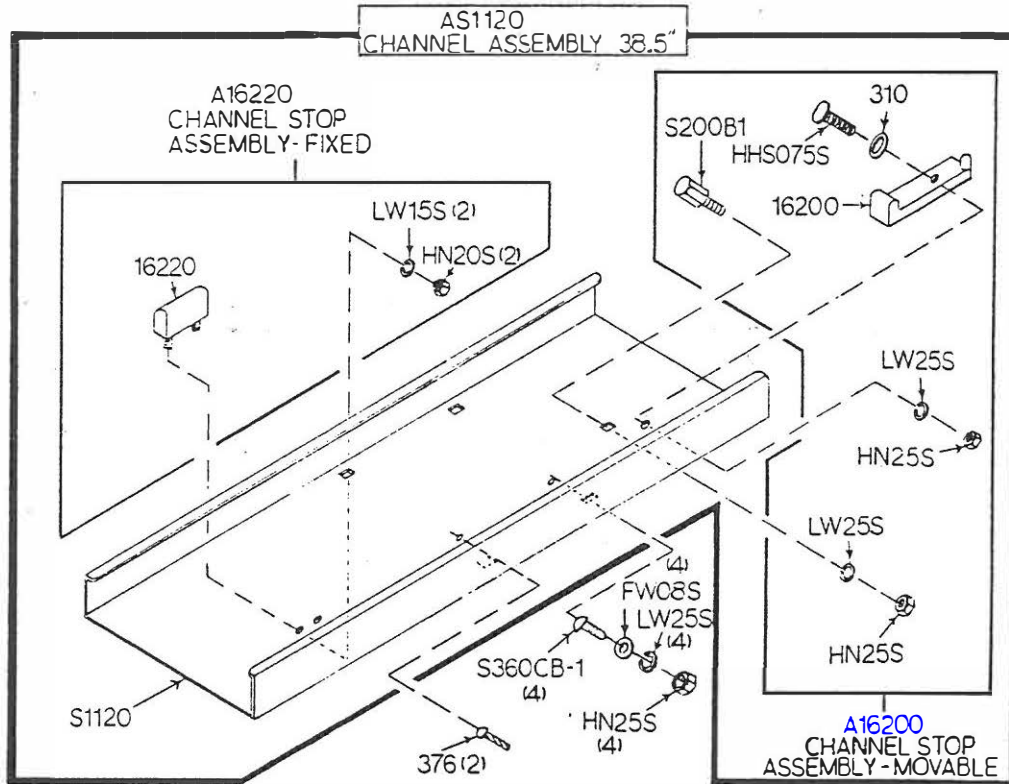

Item No.  
**A16200**  
**A16220**  
**AS1120**  
**FW08S**  
**FW15S**  
**HHS075S**  
**HN20S**  
**HN25S**  
**LW15S**

**Description**  
 Carriage stop assembly, movable  
 Carriage stop assembly, fixed  
 Channel assembly, 38.5"  
 Flat washer, 3/8 SS  
 Flat washer, 1/2 SS  
 Hex head screw, 3/8-16 x 1 1/4 SS  
 Hex nut, 5/16-18 SS  
 Hex nut, 3/8-16 SS  
 Lock washer, 5/16 SS

**LW25S**  
**S1120**  
**S200B1**  
**S360CB-1**  
**16200**  
**16220**  
**310**  
**376**

Lock washer, 3/8 SS  
 Channel, 38.5" SS  
 Carriage stop stud SS  
 Carriage bolt 3/8-16 x 1 1/4 SS  
 Carriage stop, movable  
 Carriage stop, fixed  
 Waved washer  
 Drive screw 10 x 1/2 SS

**A609AAW-18  
SWITCH ASSEMBLY**

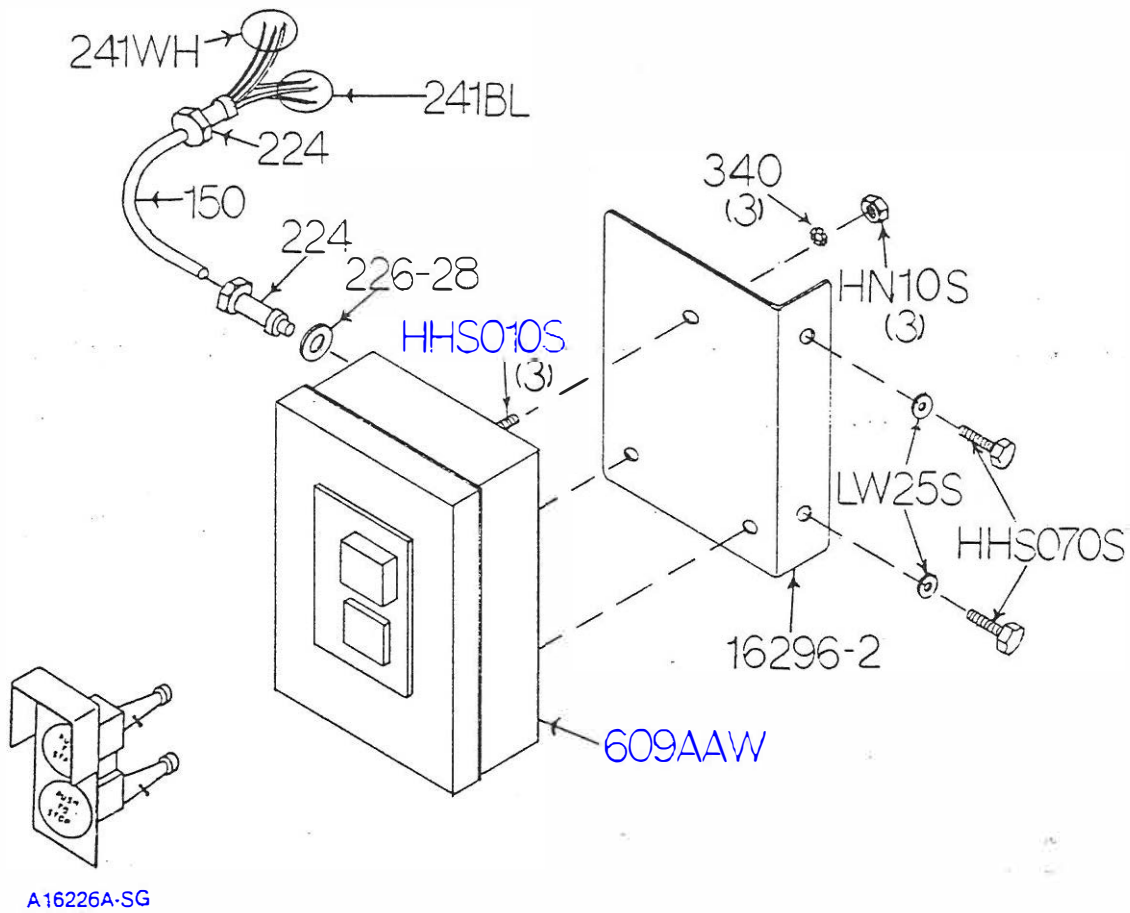

Item No.	Description
A16226A	Green/red switch button assembly w/springs
A609AAW-18	Switch assembly less heater coils
HNS010S	Hex head screw, 10-32 x 3/8 SS
HNS070S	Hex head screw, 3/8-16 x 1 SS
HN10S	Hex nut, 10-32 SS
LW25S	Lock washer, 3/8 SS
16296-2	Switch bracket SS
150	Conduit, 1/2"
224	Conduit connector, 180°
226-28	Washer SS
241BL	Wire, black, 12GA., CSA E, UL
241WH	Wire, white, 12GA., CSA & UL
340	Star lock washer
609AAW	Manual switch, size 0

# 609AAW

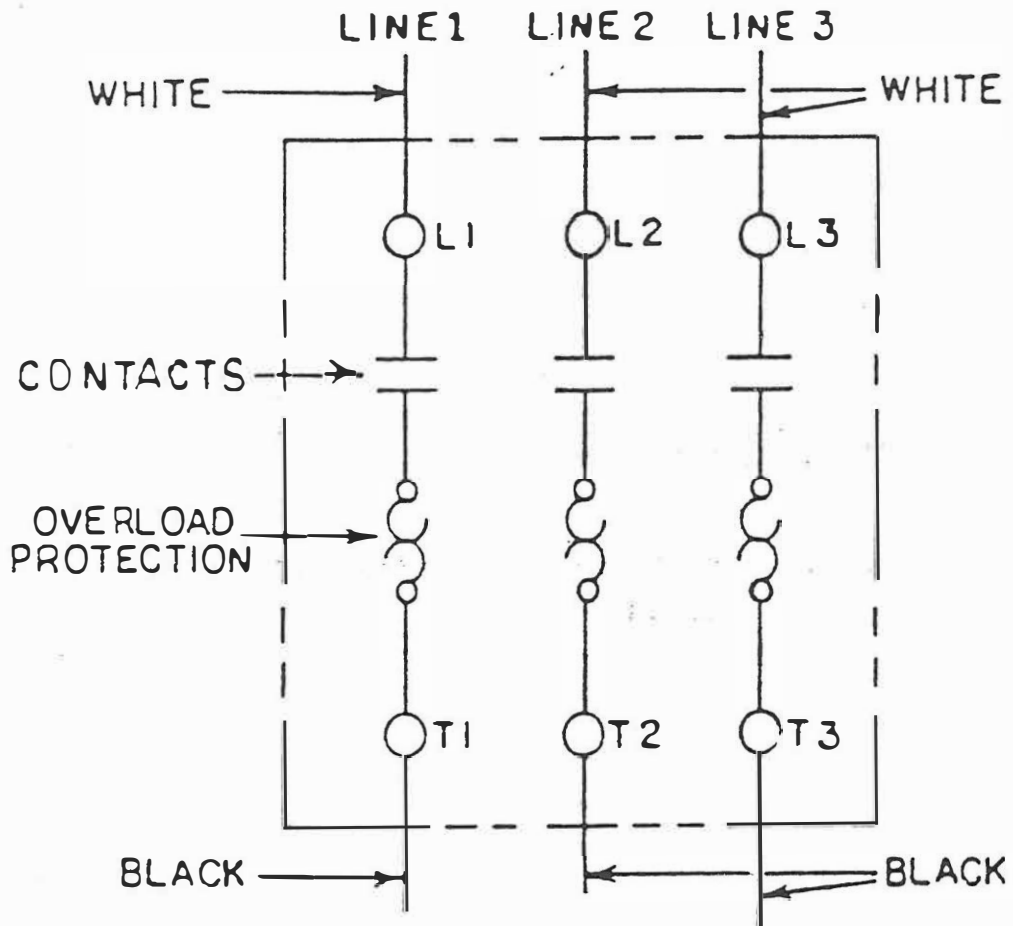

**WATERTIGHT MAGNETIC SWITCH ASSEMBLIES  
(STROMBERG)  
INCLUDES MOUNTING BRACKET AND WIRES**

Item No.	Description
A22618SG-532	BOK/PC-PB/A12, 3HP, 208/220/230-50/60-3
A22618SG-534	BOK/PC-PB/B6, 3HP, 440/460-60-3
A22618SG-536	BOK/PC-PB/C6, 3HP, 380/415-50-3
A22618SG-538	BOK/PC-PB/D4.2, 3HP, 550/575-60-3
A22618SG-539	BOK/PC-PB/A20, 5HP, 208/230-60-3
A22618SG-542	BOK/PC-PB/A01-20, 5HP, 220-50-3
A22618SG-544	BOK/PC-PB/B10, 5HP, 440/460-60-3
A22618SG-546	BOK/PC-PB/C12, 5HP, 380/415-50-3
A22618SG-548	BOK/PC-PB/D8, 5HP, 550/575-60-3

STROMBERG  
WATERTIGHT MAGNETIC  
SWITCH ASSEMBLY

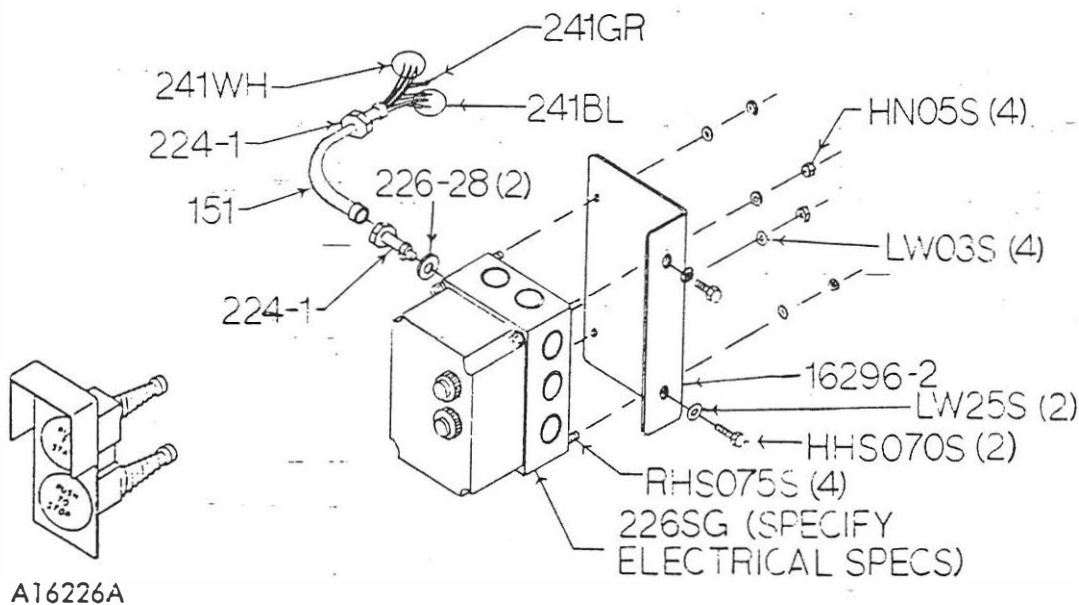

A16226A

Item No.	Description	Item No.	Description
A16226A-SG	Green/red switch button assembly	226SG-S0CC	Contactor, Size 0, OK0W10L-380/415
HHS070S	Hex head screw, 3/8-16 x 1 SS	226SG-S0DD	Contactor, Size 0, OK0W10L-550/575
HN05S	Hex nut, 8-32 SS	226SG-S1AA	Contactor, Size 1, OK01W10L-208/220/230
LW03S	Lock washer, #8 SS	226SG-S1EE	Contactor, Size 1, OK01W10L-104/115
LW25S	Lock washer, 3/8 heavy SS	226SG-512	BOK/PC-PB/A6
RHS075S	Round head screw, 8-32 x 3/4 SS	226SG-514	BOK/PC-PB/A8
16296-2	Switch bracket SS	226SG-516	BOK/PC-PB/B3
151	Watertight conduit	226SG-518	BOK/PC-PB/C4.2
224-1	Conduit connector, WT, 180°	226SG-520	BOK/PC-PB/E01-22
226SG-BOX	Switch box less cover	226SG-522	BOK/PC-PB/A01-12
226SG-CVR-B	Switch box cover with button holes	226SG-524	BOK/PC-PB/E01-32
226SG-ENCL-PB	Switch box complete with button holes	226SG-526	BOK/PC-PB/A01-15
226SG-GR	Green start button	226SG-528	BOK/PC-PB/B4.2
226SG-RD	Red stop button	226SG-530	BOK/PC-PB/D3
226SG-OLK03	Overload relay, PATAM1K 3	226SG-531	BOK/PC-PB/A10
226SG-OLK04.2	Overload relay, PATAM1K 4.2	226SG-532	BOK/PC-PB/A12
226SG-OLK06	Overload relay, PATAM1K 6	226SG-534	BOK/PC-PB/B6
226SG-OLK08	Overload relay, PATAM1K 8	226SG-535	BOK/PC-PB/C6
226SG-OLK10	Overload relay, PATAM1K 10	226SG-538	BOK/PC-PB/D4.2
226SG-OLK12	Overload relay, PATAM1K 12	226SG-540	BOK/PC-PB/A15
226SG-OLK15	Overload relay, PATAM1K 15	226SG-541	BOK/PC-PB/A18
226SG-OLK18	Overload relay, PATAM1K 18	226SG-543	BOK-PC-PB/B8
226SG-OLK22	Overload relay, PATAM1K 22	226SG-548	BOK/PC-PB/D8
226SG-OLK32	Overload relay, PATAM1K 32	226-28	Washer, 1 1/2 x 27/32 SS
226SG-S0AA	Contactor, Size 0, OK0W10L-208/220/230	241BL	Wire, black, 12 GA., CSA & UL
226SG-S0BB	Contactor, Size 0, OK0W10L-440/460	241GR	Wire, green, 12 GA., CSA & UL
		241RD	Wire, red, 12 GA., CSA & UL
		241WH	Wire, white, 12 GA., CSA & UL

**Model 44 Schematic Using 3PH Stromberg W.T. Switch for 220/440 Volts, Three Phase, 60 Cycle Baldor Motor**

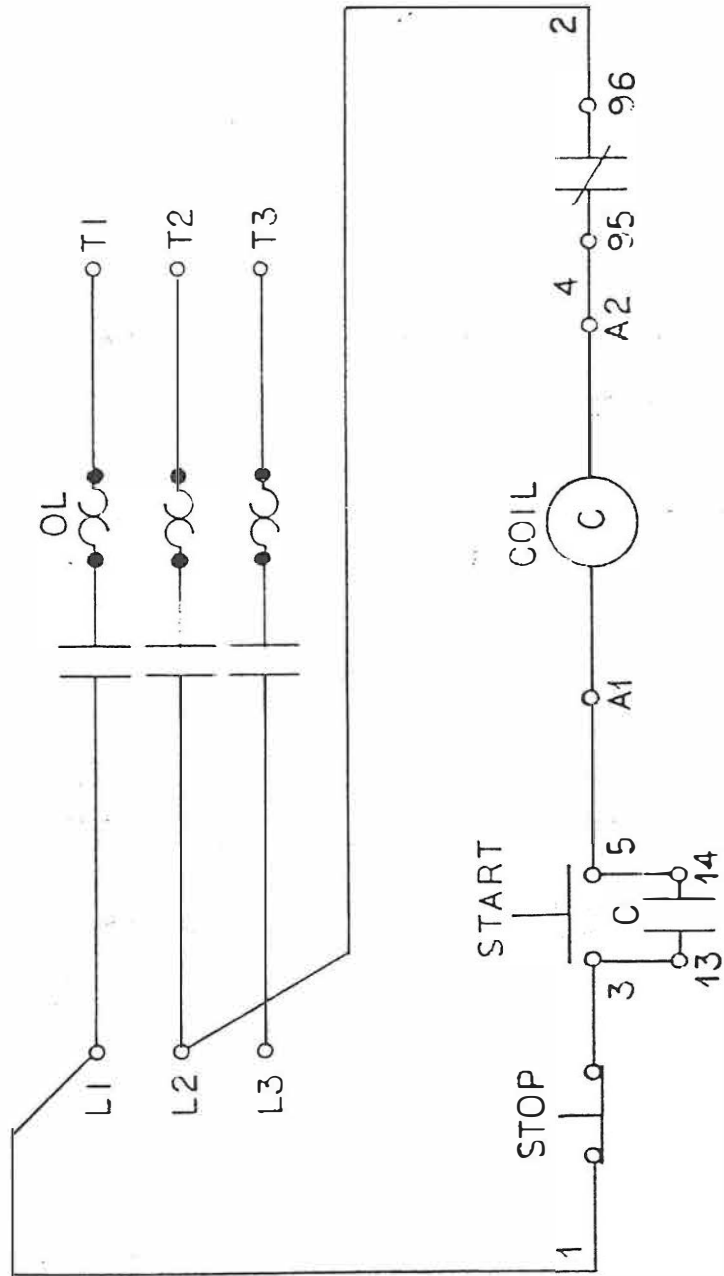

# MODEL 44 PARTS NUMBERS AND DESCRIPTIONS

## SEND IN MODEL NO. AND SERIAL NO. WHEN ORDERING PARTS

### MOTOR SECTION

Item No.	Description
<b>M76-90960-D</b>	Motor, 2 HP, 230-60-1, open
<b>M79-90934-D</b>	Mtr, 3HP, 208/220/440-50/60-3opn
<b>M82-90977-D</b>	Mtr 3HP, 208/220/440-50/60-3, enc
<b>M84-92106-D</b>	Motor, 3HP, 575-60-3, open
<b>M88-90973-D</b>	Mtr, 5HP, 220/440-50/60-3, encap
Item No.	Description
<b>FW05S</b>	Flat washer, SS, 1/4 SAE
<b>HHS060S</b>	Hex head screw, SS, 5/16-18 x 1
<b>S1007</b>	Channel bracket SS #3850 on
<b>S11</b>	Ratchet trigger, stainless
<b>S1120</b>	Channel SS #3850 on
<b>S155-11</b>	Meat carriage stop thumb screw, SS
<b>S155B</b>	Meat carriage stop welded
<b>S16296</b>	Switch brkt, SS for 609AAW, BAW
<b>S163F</b>	Platter spacer weld button, SS
<b>S18189</b>	Ratchet arm stud, SS
<b>S18253</b>	Upper wheel aligning screw, SS
<b>S200B1</b>	Stop stud gde bar & crg stp SS
<b>S217C</b>	Base door hinge pin long SS
<b>S217E</b>	Base door hinge pin short SS
<b>S235</b>	Taper pin, stainless, 4 x 3/4
<b>S239-B30</b>	Base foot welded, SS
<b>S244</b>	Wheel cleaner arm stud SS
<b>S262</b>	Meat gauge release handle, SS
<b>S268</b>	Stationary bar hdless screw SS
<b>S325</b>	Wheel cleaner washer, SS
<b>S360CB-1</b>	Carriage bolt 3/8-16 x 1 1/4, SS
<b>S416</b>	Platter locator weld pin, SS
<b>10A</b>	Ratchet arm taper pin
<b>11</b>	Ratchet trigger, replaced by S11
<b>112-212</b>	Waved washer, 2 1/64 ID, 5/8 OD
<b>116-27</b>	Saw guide bar 27 inch
<b>119A</b>	Saw guide stationary bar
<b>119FSC</b>	Saw guide stationary bar fish
<b>120E</b>	Flat head screw 5/16-18 x 2" SS
<b>130</b>	Saw cleaner bracket rear
<b>131</b>	Saw cleaner SS
<b>14TH</b>	Head door hinge #5704 on
<b>14TP</b>	Headr hinge pin long #5704 on
<b>14TP-1</b>	Headr hinge pin shrt #5704 on
<b>16Z</b>	Lower gde brkt saw clnr holder
<b>16112-1</b>	HxHdbolt, SS, 5/16-18 x 1 hddr latch, replaced by <b>HHS060S</b>
<b>16132</b>	Saw cleaner brkt holder rear
<b>16155-13</b>	Carriage stop angle SS
<b>16155-2A</b>	Meat carriage guide
<b>16155-2B</b>	Meat carriage guide spacer 1/64
<b>16155-2C</b>	Meat carriage guide spacer 1/32
<b>16159</b>	Meat carriage bearing
<b>16200</b>	Carriage stop movable
<b>16220</b>	Carriage stop fixed
<b>16226A-5</b>	Switch button plate rivet
<b>16226A-6</b>	Switch button speed nut
<b>16226A-8</b>	Switch buttonhole filler plate
<b>16296</b>	Switch bracket 609AAW, BAW, replaced by 16296-2
<b>16296-1</b>	Switch bracket mag 709AAA, AAT, replaced by 16296-2

Item No.	Description
<b>16296-2</b>	Switch bracket, SS
<b>163A</b>	Platter rod clip
<b>163F</b>	Platter spacer weld button use S163F
<b>163K</b>	Platter spacer strip, repl. by 18163L
<b>17-3</b>	Fngrlift wshr, 3/16 x .276 x .104, use FW05S
<b>17Z</b>	Replaced by A116-27 & 661-1
<b>17Z-1</b>	Upper saw guide plate
<b>17211-22</b>	Finger lift shim .022
<b>17211-35</b>	Finger lift shim .035
<b>175-1-S</b>	Thumb guard nut, SS
<b>175-2-S</b>	Thumb screw 1/4 D x 1/2 long
<b>175S</b>	Thumb guard, nylon
<b>179</b>	Wheel cleaner
<b>18001</b>	Upper main bearing spacer
<b>18003TFL</b>	Lower saw wheel 18 inch, teflon
<b>18003UTFL</b>	Upper saw wheel 18 inch, teflon
<b>18111</b>	Tension spring pin
<b>18113</b>	Tension spring plate
<b>18163B</b>	Platter neck guard
<b>18163B-1</b>	Platter neck guard, ENGLAND
<b>18163L</b>	Platter spacer strip channel, SS
<b>18196</b>	Tension spring
<b>18197</b>	Tension spring gauge
<b>18212W</b>	Platter rod
<b>18228</b>	Replaced by A116-27 & 661-1
<b>18230DL</b>	Upper shaft seal, double lip
<b>18231DL</b>	Lower shaft seal, double lip
<b>18232</b>	Scrap bucket
<b>18239FB</b>	Motor base plate adjustable
<b>18247</b>	Upper shaft
<b>18248</b>	Upper wheel hub cap
<b>18251AL</b>	Up v-belt pulley 12.8 x 1 1/8, aluminum
<b>18252</b>	Upper shaft lock nut
<b>18260</b>	Slide gib, aluminum
<b>18272</b>	Meat gauge gear rack
<b>18273</b>	Meat gauge bracket
<b>18275</b>	Meat gauge arm
<b>18275-2</b>	Meat gauge plate
<b>18280</b>	Motor shaft key
<b>18300</b>	Lower shaft woodruff key
<b>18301</b>	Name plate, round
<b>18302</b>	Saw blade, 135 inch
<b>18305</b>	Saw guide bar stop in head
<b>18308</b>	Model number plate, Ser. No. required
<b>18311</b>	Rubber bumper for stops
<b>18313-105</b>	Operating manual
<b>18335X</b>	Upper wheel hinge plate
<b>18360</b>	Lower bearing housing
<b>18361</b>	Lower shaft
<b>19CB</b>	Ratchetbase carriage bit, 3/4 SS
<b>193</b>	Saw guide bar spring
<b>211A-291</b>	Fngrlft clngunit knob — 3/8 short, replaced by 211A-291Q
<b>211A-291Q</b>	Finger lift fastener knob, plastic, 4 point
<b>211D</b>	Finger lift fastener bolt 3/8-16 x 1 3/4
<b>212CP</b>	Hold down rod cotter
<b>221-57</b>	V-belt, 57 inch
<b>224</b>	Conduit connector 180°
<b>228-1</b>	Replaced by A116-27 & 661-1
<b>228-2</b>	Lwr saw guide washer, 1/4 x 7/8 x 1/16
<b>234</b>	Grease fitting upper wheel
<b>237</b>	Up shaft castellated lock nut
<b>238</b>	Up shaft castld lock nut washer

Item No.	Description
239-B30-1	Base foot, carbon, replaced by S239-B30
239-B31-2	Pipe leg, aluminum, 6"
239-B32-AR	Pipe leg cap
239-B34	Base foot insert w/sleeve, SS
240	Ratchet trigger spring
242R	Base door lock, right
247A	Upper shaft washer
249	Base door handle
252X	Shaft lock nut
256P	Safety pusher plate, compostn
256PM	Safety pusher plate, aluminum
259	Anti-short bushing 1/2
264-1	Meat gauge hand wheel
264G	Meat gauge hand whl groove pin
265	Meat gauge release spring
267	Meat gauge release cotter key
270	Meat gauge release pin
271	Meat gauge worm gear
272-6-S	Meat gauge bracket wing nut
275THS	Truss head screw, 1/4-20 x 3/8
275THS-1	Truss head screw, 1/4-20 x 1
277	Lower shaft key
290-7	Cleaning unit locator button use 290-8K
290-8K	Cleaning unit locator kit
292	Switch rod knob
296-10	Switch bracket 709BAA 5HP

Item No.	Description
296-3	Sw bracket, ACW, BCW, AAA1, TAA1
296A	Switch bracket, England & Norway
299L	Saw guide bar stop long
310	Waved wshr mvblcrgr stp hddrck
324A	Motor shim 1/8 inch
334-6-S	Nylon saw rider
340	Star lock washer
360A1	Lower brg hngng angl grease fit
360B	Lower brg hngng tilt set screw
362	Lower bearing housing cap
374	M-6 Lubriko grease, 14 oz. can
375	Drive screw, name & model plate
376	Drive screw #10 x 1/2, SS
4-40AL	Motor pulley 5 x 1, aluminum
415D	Stationary bar
416	Platter locator weld pins, use S416
512	Upper wheel hub gasket
601	Upper saw guide bracket
602A	Saw guide upper
602AFSC	Saw guide upper bracket, fish
605	Saw guide, lower blade back-up
71-2	Upper wheel hinge bracket

## COMPLETE ASSEMBLIES FOR MODEL 44

Item No.	Description	Item No.	Description
A130	Saw cleaner assembly	A18227	Main brg cup/cone assem up & lwr
A16Z	Guide brkt saw cleaner assem	A18247	Upr shaft brg assem w/o wheel
A16200	Channel stop assembly movable	A18275	Meat gauge plate assembly
A16220	Channel stop assembly fixed	A18360	Lower bearing housing assembly, w/o wheel
A16226A	Green/red sw button assem, w/spring	A211	Finger lift assembly removable
A18003(ITFL	Up whl assem w/o hinge plate, teflon	A249R	Base door handle assem right
A18003(UTFL335	Up whl assem w/hinge plate, teflon	A262	Meat gauge release assembly
		A602	Saw guide assembly upper

## TRUE LEFT PART NUMBERS AND DESCRIPTIONS

ITEM NO.	DESCRIPTION	ITEM NO.	DESCRIPTION
LH181155	Left Hand Meat Carriage	TL18019	True Left Ratchet Base
LH211	Left Hand Finger Lift	TL18217L	True Left Hinged Base Door, SS
LH662	Left Hand Saw Guard	TL18239	True Left Base, SS
TL16112	True Left Head Door Latch, SS	TL229	True Left Wheel Cleaner Arm Spring
TL177	True Left Nylon Filler	TL290-11F	True Left Cleaning Unit Stamping
TL18005	True Left Head, SS	TL295	True Left Wheel Cleaner Arm
TL18006	True Left Head Door, SS	TL335	True Left Upper Wheel Hinge Plate
TL18010	True Left Ratchet Arm	TL415	True Left Stationary Bar, SS
TL18011	True Left Ratchet Trigger, SS		

## COMPLETE TRUE LEFT ASSEMBLIES

ITEM NO.	DESCRIPTION	ITEM NO.	DESCRIPTION
ALH116-27	Left Hand Saw Guide Bar Assembly	ATL18019	True Left Ratchet Assembly
ALH181155	Left Hand Meat Carriage Assembly	ATL18163	True Left Platter Assembly
ALH18211-602	Left Hand Finger Lift Assembly	ATL290-11F	Cleaning Unit Assembly, Front
ATL16112	True Left Head Door Latch Assembly	ATL295	True Left Wheel Cleaner Assembly
ATL18005	True Left Head & Door Assembly, SS	ATL30335	True Left Up Wheel Assembly w/Hinge
ATL18006	True Left Head Door Assembly, SS	ATL415	True Left Sta. Bar Assembly, SS

# CLEANING

## ▲ WARNING

### SHARP MOVING BAND TYPE SAW BLADE TO AVOID SERIOUS PERSONAL INJURY

**ALWAYS** Turn Off, Unplug from Power Source and Perform Lockout/Tagout Procedure to this Machine **BEFORE** Cleaning or Servicing.

**ONLY** Use Recommended Cleaning Equipment, Materials and Procedures.

**NEVER** Spray Water or Other Liquid Substances Directly at Motor, Power Switch or any Other Electrical Components.

**ALWAYS** Thoroughly Clean Equipment at least Daily.

#### CLEANING THE BIRO POWER CUTTER:

Disconnect electrical power to the machine before cleaning. Parts to be removed have been made accessible and can be removed without tools. Notice in the drawing below that all parts are numbered. Each part should be removed for cleaning in the numbered sequence shown. To ensure cleaner cuts, keep the parts on the cleaning system in good condition. Parts on the cleaning system which should be checked weekly, and changed as required as follows: Wheel Cleaners (Part No. 179), Saw Cleaners (Part No. 131), Saw Guide in Stationary Bar (Part No. 119A), Upper Saw Guide (Part No. 602B), Lower Blade Back-Up Guide (Part No. 605) and Nylon Filler (Part No. 177).

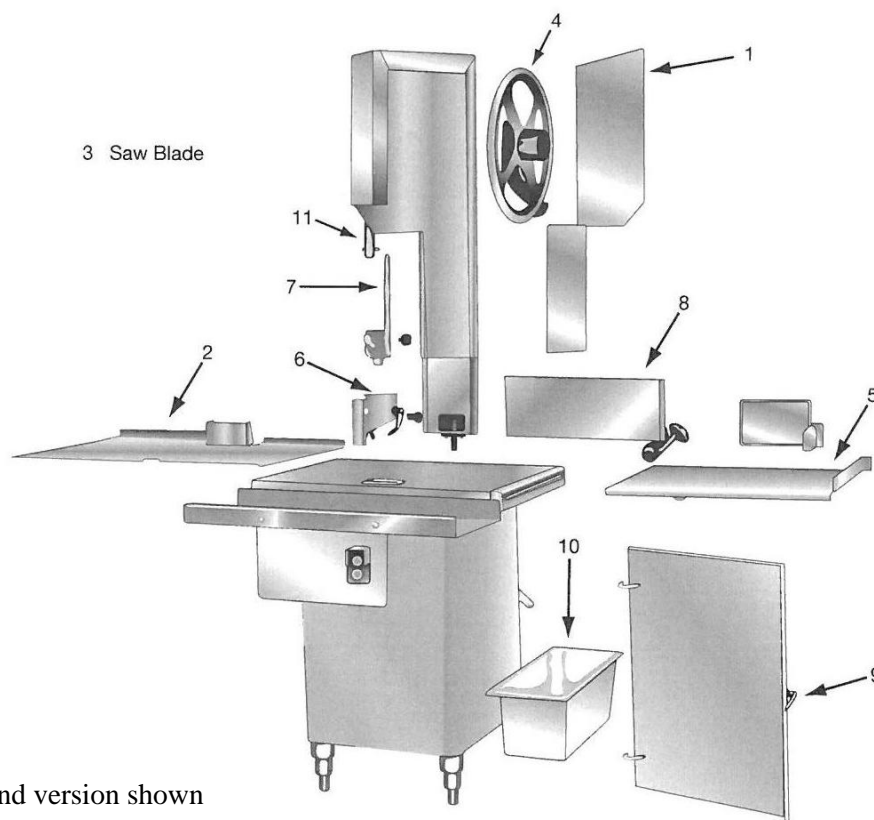

Right hand version shown

## **LIMITED WARRANTY:**

**WARRANTY:** The BIRO Manufacturing Company warrants that the Model 44TL Power Meat Cutter will be free from defects in material and workmanship under normal use and with recommended service. BIRO will replace defective parts, which are covered by this limited warranty, provided that the defective parts are authorized for return, shipping charges prepaid, to a designated factory for inspection and/or testing.

**DURATION OF WARRANTY:** The warranty period for all parts covered by this limited warranty is one (1) year from date of Inspection/Demonstration as advised on the returned Warranty Registration card, or eighteen (18) months from original factory ship date, whichever occurs first, except as noted below.

**PARTS NOT COVERED BY WARRANTY:** The following are **not** covered by this limited warranty: wearable parts on the cleaning system such as wheel cleaners (Item No. 179), saw blade cleaners (Item No. 131), blade backup guides (Item No's. 602B, 605 and 119A), and the nylon filler (Item No. 177). This limited warranty does not apply to machines sold as used, rebuilt, modified, or altered from the original construction in which the machine was shipped from the factory. (WATER CONTAMINATED ELECTRICAL SYSTEMS ARE NOT COVERED UNDER THIS LIMITED WARRANTY.) BIRO is not responsible for electrical connection of equipment, adjustments to the switch controls or any other electrical requirements, which must be performed only by a certified electrician. BIRO is not responsible for service charges or labor required to replace any part covered by this limited warranty or for any damages resulting from misuse, abuse, lack of proper or recommended service.

**EXCLUSION OF WARRANTIES AND LIMITATION OF REMEDIES:** BIRO gives no warranties other than those expressly stated in this limited warranty. THE IMPLIED WARRANTY OF MERCHANTABILITY, THE IMPLIED WARRANTY OF FITNESS FOR PROCESSING OF FOOD PRODUCTS, AND ALL OTHER IMPLIED WARRANTIES ARE SPECIFICALLY EXCLUDED. BIRO IS NOT LIABLE FOR CONSEQUENTIAL OR INCIDENTAL DAMAGES, EXPENSES, OR LOSSES. THE REMEDIES PROVIDED IN THIS BIRO LIMITED WARRANTY ARE PURCHASER'S SOLE AND EXCLUSIVE REMEDIES AGAINST BIRO.

**REGISTRATION CARDS:** You must sign, date, and complete warranty registration card supplied with each machine. The warranty card must be returned to The BIRO Manufacturing Company for proper registration. If no warranty card is returned to BIRO, the warranty period will begin from the date the machine was originally shipped from the factory.

## **HOW TO GET SERVICE:**

1. Contact the agency from whom you purchased the machine; or
2. Consult the yellow pages of the phone directory for the nearest authorized dealer; or
3. Contact BIRO Mfg.Co. for the nearest authorized service agency in your area.

## **THE BIRO MANUFACTURING COMPANY**

**1114 W. Main Street**

**Marblehead, OH 43440-2099 U.S.A.**

**Ph. 419-798-4451 Fax 419-798-9106**

**Email: [service@birosaw.com](mailto:service@birosaw.com)**

**[www.birosaw.com](http://www.birosaw.com)**