



**MODEL 44 POWER MEAT CUTTER
OPERATING AND SERVICE MANUAL
STARTING WITH SERIAL NO. 3850**



☆ **IMPORTANT NOTICE** ☆

This Manual contains important safety instructions which must be strictly followed when using this equipment.

TABLE OF CONTENTS

	Page
NOTICE TO OWNERS AND OPERATORS	1
SAFETY TIPS.....	2
INSTALLATION	3-5
OPERATION.....	6
TO PROCESS PRODUCT	6-7
CLEANING.....	8
MAINTENANCE	9
GENERAL	9
LUBRICATION.....	10
SAW GUIDE BAR AND SAW GUARD	11
PARTS DIAGRAMS.....	12-19
LONGER SAW GUARD KIT.....	20
OPERATOR'S NOTES	21
SWITCH ASSEMBLIES AND SERVICE PARTS.....	22 & 24
WIRING DIAGRAMS.....	23 & 25
WEARABLE SAW PARTS LIST	26
PARTS LIST/ORDERING	27
PARTS ASSEMBLIES LIST/ORDERING	28
WARNING LABEL LOCATIONS ON MACHINE	29
WALL CHART (PART NO. 671)	30
OPERATOR'S SIGNATURE PAGE	31
LIMITED WARRANTY	32

NOTICE TO OWNERS AND OPERATORS

BIRO's products are designed to process food products safely and efficiently. Unless the operator is properly trained and supervised, there is the possibility of a serious injury. It is the responsibility of the owner to assure that this machine is used properly and safely, strictly following the instructions contained in this Manual and any requirements of local law.

No one should use or service this machine without proper training and supervision. All operators should be thoroughly familiar with the procedures contained in this Manual. Even so BIRO cannot anticipate every circumstance or environment in which its products will be used. You, the owner and operator, must remain alert to the hazards posed by the function of this equipment – particularly the SHARP MOVING BAND TYPE SAW BLADE. No one under eighteen (18) years of age should operate this equipment. If you are uncertain about a particular task, ask your supervisor.

This Manual contains a number of safe practices in the SAFETY TIP section. Additional warnings are placed throughout the Manual. Warnings related to your personal safety are indicated by:



OR



Warnings related to possible damage are indicated by:



BIRO also has provided a wall chart to be posted near the equipment. If any warning label, wall chart, or Manual becomes misplaced, damaged, or illegible, please contact your nearest Distributor or BIRO directly for a replacement.

Remember, however, this Manual or the warning labels do not replace the need to be alert and to use your common sense when using this equipment.

This Manual applies to machines with serial number 3850 and higher, except where noted.

– NOTE –

A copy of this manual is included with each MODEL 44 POWER SAW.

**The descriptions and illustrations contained in this manual are not binding.
The manufacturer reserves the right to introduce any modification without updating the manual.**

SAFETY TIPS



SHARP MOVING BAND TYPE SAW BLADE TO AVOID SERIOUS PERSONAL INJURY

NEVER Touch This Machine Without Training and Authorization By Your Supervisor.

ALWAYS Read Operation and Service Manual **BEFORE** Operating, Cleaning or Servicing.

ALWAYS Keep Hands Clear of Sharp Band Type Saw Blade and Other Moving Parts.

ONLY Use a Qualified Electrician to Install According to Local Building Codes: Machine **MUST** Be Properly Grounded.

ONLY Install on Level, Non-Skid Surface in a Clean Well-Lighted Work Area Away from Children and Visitors.

DO NOT Attempt to Operate This Machine Until it has Been Inspected and Demonstrated by the Seller – Recognized **BIRO** Representative.

DO NOT Alter or Modify This Machine in any Way From its Original Form. This Machine in its Original Form Meets the Intent of O.S.H.A. Applicable Standards.

NEVER Operate with Saw Guard on Saw Guide Bar in the Raised Position or the Saw Guard Removed from the Saw Guide Bar.

ALWAYS Adjust Saw Guide Bar with Saw Guard to Within $\frac{1}{2}$ " of Product to be Cut.

ALWAYS Use Safety End Cut Pusher Plate for Smaller Products or the Last Cuts of Product.

DO NOT Use This Machine for Non-Food Products.

DO NOT Use This Machine to Cut Pigs Feet.

DO NOT Wear Gloves While Operating.

ALWAYS Turn Off, Unplug From Power Source and Perform Lockout/Tagout Procedure to This Machine **BEFORE** Removing Shrouds, Removable Guards, Cover, Doors, Fences or Panels for Cleaning, Servicing or any Other Reason.

NEVER Leave Machine Unattended While Operating.

PROMPTLY REPLACE Any Worn or Illegible Warning Labels.

USE ONLY BIRO Parts and Accessories Properly Installed.

INSTALLATION



TO AVOID SERIOUS PERSONAL INJURY PROPERLY INSTALL EQUIPMENT IN ADEQUATE WORK AREA

ALWAYS Use Qualified Technician and Electrician for Installation.

ALWAYS Install Equipment in Work area with Adequate Light and Space.

ONLY Operate on a Solid, Level, Non-Skid Surface.

NEVER Operate with Saw Guard on Saw Guide Bar in the Raised Position or the Saw Guard Removed from the Saw Guide Bar.

ALWAYS Adjust Saw Guide Bar with Saw Guard to Within $\frac{1}{2}$ " of Product to be Cut.

NEVER Operate Without all Warning Labels Attached and Wall Chart Posted.

1. Read this Manual thoroughly before installation and operation. Do not proceed with installation and operation if you have any questions or do not understand anything in this Manual. Contact your local Distributor, or BIRO first.
2. Install machine on a level, solid, non-skid surface in a well-lighted work area away from children and visitors.



ALWAYS LEVEL MACHINE BEFORE USING

3. After installing machine in operational area, it is imperative that the four adjusting leg hex bolts be adjusted to level the machine and also to eliminate rocking.
4. To assemble meat gauge plate (Part No. [A18275](#)) to the machine; Loosen the lock knob (Part No. 272-7) on the right side of meat gauge bracket. Raise the meat gauge gear rack (Part No. 18272) and slip the meat gauge plate over the gear rack. Lower the gear rack back to its original position, tighten lock knob. Keep gear rack well oiled with food grade oil to ensure free movement.
5. The head structure (Part No. [S18005](#)) comes detached from the base. Slip the head into the slide gibs (Part No. [18260](#)) located on the back of the base structure. Make sure the slide gibs are oiled or greased to ensure free vertical movement of the head structure.

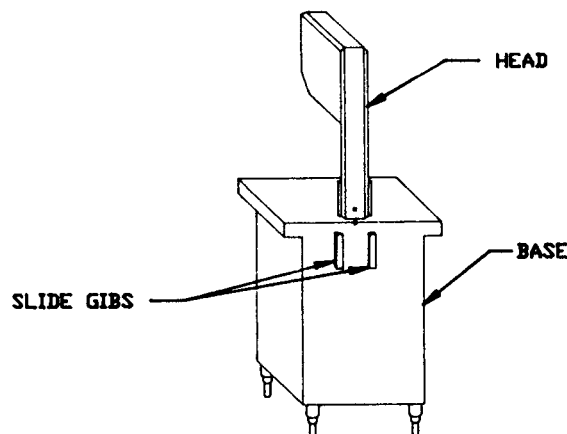

6. Place removable finger lift with saw guard assembly (Part No. [A18211](#)) on the saw guide bar (Part No. [116-27](#)) and fasten in place with finger lift fastener knob (Part No. [211A-291Q](#)).



SHARP SAW BLADE. HANDLE WITH EXTREME CAUTION.

7. Placing blade on cutter: Hang upper wheel assembly (Part No. [A18003U335](#)) on the hinge bracket (Part No. 71-2). Lift the nylon filler (Part No. [177](#)). Hang blade on the upper wheel and hold with right hand. With left hand force the back of the blade between the front blade cleaners (Part No. [131](#)), located below the nylon filler. Lower the nylon filler and insert the back of the blade in the upper saw guide (Part No. [602B](#)). The blade has already dropped over the lower wheel. With right hand force the back of the blade between the rear blade cleaners (Part No. [131](#)). The blade is now ready to be tightened. Press down on the ratchet arm (Part No. [18010](#)) located at the rear of the base structure. Turn the upper wheel slowly by hand to ensure proper tracking of the saw blade on the wheels. Tighten to proper tension. When the tension gauge (Part No. [18197](#)), located at the bottom rear of the head becomes tight laterally the blade is at proper tension.
8. The stationary platter (Part No. [A18163](#)) is placed on top of the base structure and held in place by two push-pull hold down rods (Part No. [18212W](#)), located at the back of the base structure.
9. The sliding meat carriage assembly (Part No. [A18155EZ](#)) is installed by turning the movable stop assembly (Part No. [A16200](#)) clockwise. After the carriage assembly is in the channel for operation, turn the movable stop counterclockwise to lock.
10. Post **SAFETY TIPS** wall chart within easy view of operator. Keep Manual available to operator.
11. Machine **MUST** be properly grounded. Use qualified electrician to install according to building codes.

WIRING MOTOR

- (1) Interchange of motor current is made in motor outlet box. Leads are properly marked. Changing instructions are on motor plate or motor outlet box.
- (2) All cutters are wired 220 volts unless otherwise specified. Be sure motor specifications (voltage, cycle, phase) match power supply line. Be sure line voltage is up to specification.
- (3) Connect leads to machine in a manner that will be approved by local electrical inspectors.
- (4) We recommend no less than No. 12 wire. If the leads are too light, machine may not have sufficient cutting power and/or speed.
- (5) The V-belt is packed loose in machine to prevent deformation, and must be installed on pulleys at time of wiring motor.
- (6) The BIRO Manufacturing Company is not responsible for permanent wiring, connection or installation.



NOTE TO OWNER AND ELECTRICIAN: IF THIS MACHINE IS NOT CORD AND PLUG CONNECTED TO THE ELECTRICAL SUPPLY SOURCE, THEN IT SHOULD BE EQUIPPED WITH, OR CONNECTED TO, A LOCKABLE, MANUALLY OPERATED DISCONNECT SWITCH (OSHA 1010.147).



KEEP HANDS CLEAR OF SHARP MOVING BAND TYPE SAW BLADE.

12. Make sure saw guide bar with saw guard is in its lowest position. Close head and base doors.
13. Push start button and check for proper phasing of motor. Blade should be travelling down through saw guide.
14. Watch for proper tracking of blade. Back of blade should be centered in hole in saw guide in stationary bar (Part No. 119A). Push stop button to stop machine.
15. Check placement of all warning labels, wall chart and Manual. Machine is ready for trained operators to process product.
16. Contact your local Distributor or BIRO directly if you have any questions or problems with the installation or operation of this machine.

WARNING LABELS AND WALL CHART FOR BIRO POWER CUTTERS

SEE PAGE 27 AND 28 FOR LOCATIONS ON THIS MACHINE

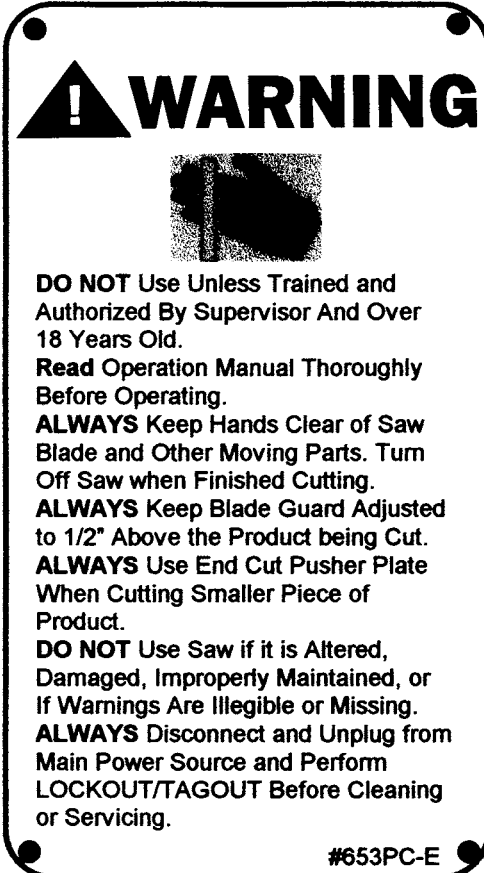

! WARNING

DO NOT Use Unless Trained and Authorized By Supervisor And Over 18 Years Old.

Read Operation Manual Thoroughly Before Operating.

ALWAYS Keep Hands Clear of Saw Blade and Other Moving Parts. Turn Off Saw when Finished Cutting.

ALWAYS Keep Blade Guard Adjusted to 1/2" Above the Product being Cut.

ALWAYS Use End Cut Pusher Plate When Cutting Smaller Piece of Product.

DO NOT Use Saw if it is Altered, Damaged, Improperly Maintained, or If Warnings Are Illegible or Missing.

ALWAYS Disconnect and Unplug from Main Power Source and Perform LOCKOUT/TAGOUT Before Cleaning or Servicing.

#653PC-E

Item No. 653PC-E

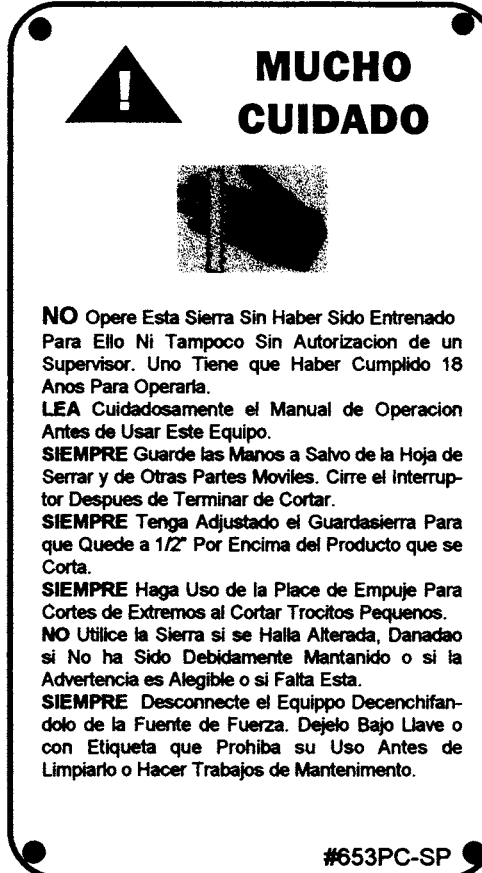

! MUCHO CUIDADO

NO Opere Esta Sierra Sin Haber Sido Entrenado Para Ello Ni Tampoco Sin Autorizacion de un Supervisor. Uno Tiene que Haber Cumplido 18 Anos Para Operarla.

LEA Cuidadosamente el Manual de Operacion Antes de Usar Este Equipo.

SIEMPRE Guarde las Manos a Salvo de la Hoja de Serrar y de Otras Partes Moviles. Cirre el Interruptor Despues de Terminar de Cortar.

SIEMPRE Tenga Ajustado el Guardasierra Para que Quede a 1/2" Por Encima del Producto que se Corta.

SIEMPRE Haga Uso de la Placa de Empuje Para Cortes de Extremos al Cortar Trocitos Pequenos.

NO Utilice la Sierra si se Halla Alterada, Danadao si No ha Sido Debidamente Mantenido o si la Advertencia es Alegible o si Falta Esta.

SIEMPRE Desconecte el Equipo Decenchifandolo de la Fuente de Fuerza. DejeLo Bajo Llave o con Etiqueta que Prohiba su Uso Antes de Limpiarlo o Hacer Trabajos de Mantenimiento.

#653PC-SP

Item No. 653PC-SP



WARNING

DO NOT TAMPER, BYPASS, REMOVE ANY SAFETY INTERLOCK SWITCHES OR OTHER SAFETY DEVICES.

ALWAYS DISCONNECT POWER SUPPLY BEFORE REMOVING SHROUDS, GUARDS, COVERS, DOORS, FENCES, PANELS, FOR CLEANING, SERVICING, REASSEMBLING, OR ANY REASON. FAILURE TO COMPLY WITH WARNING COULD RESULT IN SERIOUS BODILY INJURY.

653PS

653PS

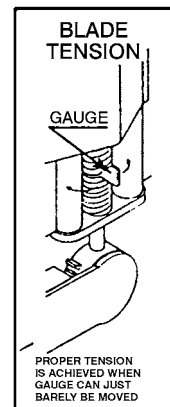

Item No. 710



ALWAYS LOWER GUARD TO HEIGHT OF PRODUCT

DANGER

EXPOSED BLADE

↓

Item No. 708

OPERATION



SHARP MOVING BAND TYPE SAW BLADE TO AVOID SERIOUS PERSONAL INJURY

ONLY Properly Trained Personnel Should Use This Equipment.

ALWAYS Keep Hands Clear of Band Type Saw Blade and Other Moving Parts.

NEVER Operate with Saw Guard on Saw Guide Bar in the Raised Position or the Saw Guard Removed from the Saw Guide Bar.

ALWAYS Adjust the Saw Guide Bar with Saw Guard to Within $\frac{1}{2}$ " of Product to be Cut.

ALWAYS Use Safety End Cut Pusher Plate for Smaller Products or The Last Cuts of Product.

DO NOT Wear Gloves While Operating.

DO NOT Tamper With, Bypass, Alter or Modify This Equipment in Any Way from its Original Condition.

ALWAYS Turn Off, Unplug from Power Source and Perform Lockout/Tag Out Procedures to This Machine Before Cleaning, Servicing or When Not in Use.

NEVER Leave Unattended While The Saw is running

NEVER Operate Without All Warning Labels Properly Affixed to Machine and Wall Chart Posted.

A. TO PROCESS PRODUCT

1. Before starting power cutter, adjust saw guide bar with saw guard down to within $\frac{1}{2}$ " (13 mm) of product to be cut.

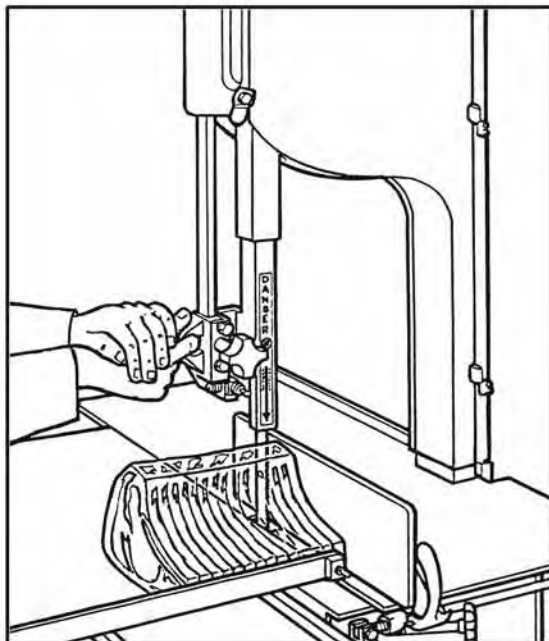



DO NOT WEAR GLOVES WHILE OPERATING

2. Make sure all doors are closed and locked.
3. Adjust meat gauge plate forward to desired thickness of cut.
4. Push start button and watch blade for proper tracking.
5. Standing in front of the power cutter, place product on the meat carriage. Pay attention to position of your hands. Keep hands clear of moving band type saw blade. Leaning lightly against the scalloped front edge of meat carriage, hold the product firmly in right hand with product face flush against meat gauge plate. Move the meat carriage from right to left at a steady rate until fully past the saw blade. Use left hand to remove and stack cut product, **NEVER REACH IN FRONT OF BAND TYPE SAW BLADE**. On the return stroke, pull the product toward you, away from saw blade.



NEVER REACH OR GRAB FOR PRODUCT IN FRONT OF MOVING BAND TYPE SAW BLADE

6. **ALWAYS** use the safety End Cut Pusher Plate (Part No. [256P](#)) for smaller products or the last cuts of product. The pusher plate is supplied as standard on all BIRO power cutters.

ONLY PROPERLY TRAINED PERSONNEL SHOULD USE THIS EQUIPMENT

This Saw Contains A Sharp Blade. To Reduce Risk of Injury:

1. Before Using, Make Sure:

- Gauge Plate (A) And Other Components Are Secure.
- All Warning Labels And Guards Are In Place.
- The Guide Bar (B) Is Adjusted To ½ Inch Above The Product To Be Cut

2. While Cutting:

- Keep Hands and Fingers Away From Blade.
- Keep Product Securely Against Gauge Plate.
- Use End Cut Pusher (C) When Making Final Cuts. Item No. 256P.

3. Before Cleaning:

- Turn Off Power and Unplug.
- Remove Saw Blade.
- Use Extra Care When Handling The Saw Blade.

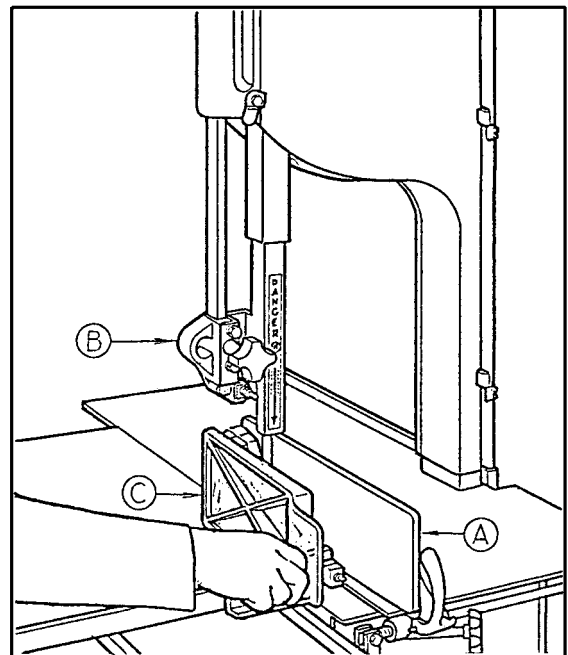

7. When finished cutting, push stop button. Perform lockout/tagout procedure.

CLEANING



SHARP MOVING BAND TYPE SAW BLADE TO AVOID SERIOUS PERSONAL INJURY

ALWAYS Turn Off, Unplug From Power Source and Perform Lockout/Tagout Procedure to This Machine **BEFORE** Cleaning or Servicing.

ONLY Use Recommended Cleaning Equipment, Materials and Procedures.

NEVER Spray Water or Other Liquid Substances Directly at Motor, Power Switch or any Other Electrical Components.

ALWAYS Thoroughly Clean Equipment at Least Daily.

CLEANING THE BIRO POWER CUTTER:

Disconnect electrical power to the machine before cleaning. Parts to be removed have been made accessible and can be removed without tools. Notice in the drawing below that all parts are numbered. Each part should be removed for cleaning in the numbered sequence shown. To ensure cleaner cuts, keep the parts on the cleaning system in good condition. Parts on the cleaning system which should be checked weekly, and changed as required are as follows: Wheel Cleaners (Part No. 179), Saw Cleaners (Part No. 131), Saw Guide in Stationary Bar (Part No. 119A), Upper Saw Guide (Part No. 602B), Lower Blade Back-Up Guide (Part No. 605) and Nylon Filler (Part No. 177).

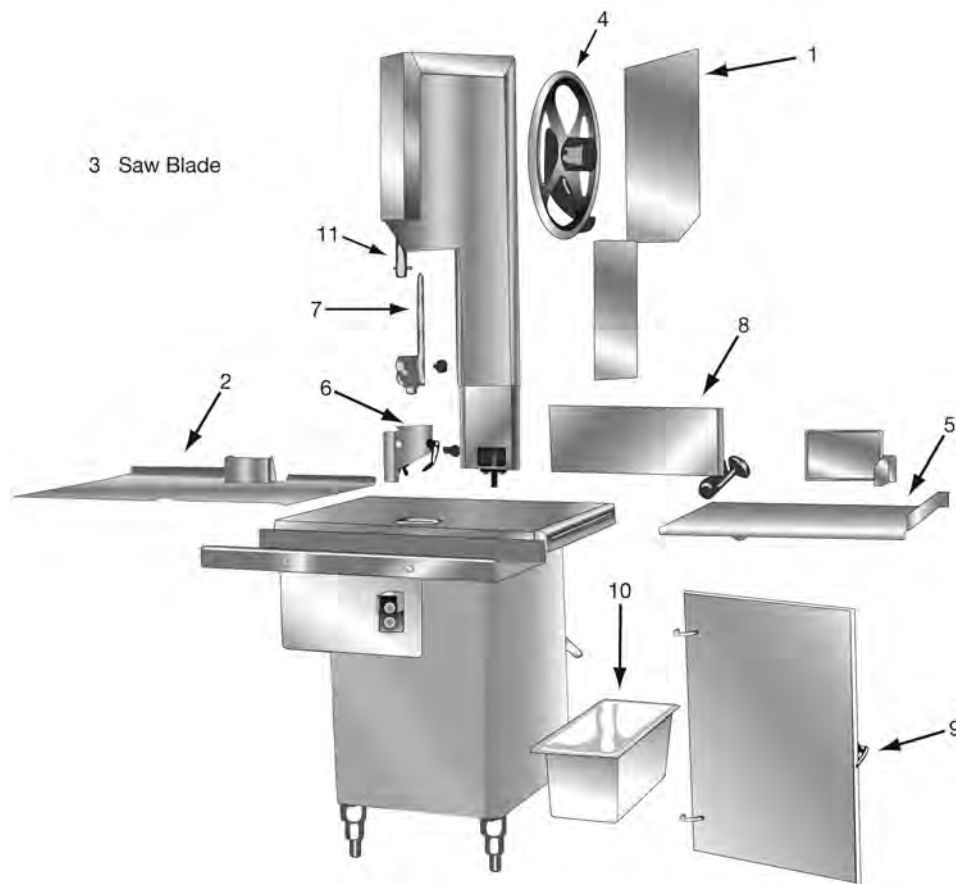

MAINTENANCE



SHARP MOVING BAND TYPE SAW BLADE TO AVOID SERIOUS PERSONAL INJURY

ALWAYS Turn Off, Unplug From Power Source and Perform Lockout/Tag Out Procedure to This Machine **BEFORE** Cleaning or Servicing.

NEVER Touch This Machine Without Training and Authorization By Your Supervisor.

ALWAYS Keep Hands Clear of Band Type Saw Blade and Other Moving Parts.

NEVER Bypass, Alter, or Modify This Equipment in Any Way From Its Original Condition.

PROMPTLY REPLACE Any Worn or Illegible Warning Labels.

USE ONLY GENUINE BIRO Parts and Accessories Properly Installed.

A. GENERAL



MACHINE SHOULD BE GENERALLY INSPECTED EVERY TIME IT IS CLEANED (AT LEAST DAILY) TO ENSURE THAT IT IS IN GOOD CONDITION AND HAS NOT BEEN DAMAGED OR TAMPERED WITH

- A. **SAW WHEELS:** Clean outer diameter grooves daily. Check for cracks, gouges or wear on the flange and grooves.



DO NOT IMMERSE UPPER WHEEL ASSEMBLY IN WATER

- B. **WHEEL CLEANER ASSEMBLIES:** Check condition of fiber cleaner, change every four (4) weeks.
- C. **REMOVABLE FINGER LIFT ASSEMBLY:** Check condition of saw guard, make sure mounting bolts are tight and the "DANGER EXPOSED BLADE" decal is affixed and legible. Check condition of upper saw guide (Part No. 602B), replace every six (6) months. Check adjustment of upper saw guide. Should be $\frac{1}{32}$ " between back of blade and saw guide carbide.



NEVER USE THIS MACHINE WITHOUT PROPERLY INSTALLED AND FUNCTIONING SAW GUIDE BAR AND SAW GUARD

- D. **SAW GUIDE BAR:** Check condition of bar for coating peeling and wear, replace as necessary. Check saw guide bar spring for proper tension. The spring should hold the bar in any desired position in its travel. Replace saw guide bar spring (Part No. 193) as necessary using instructions below.

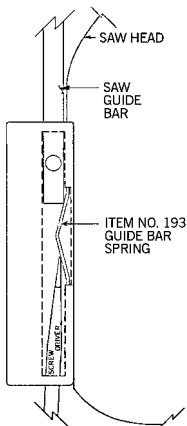

1. Remove the finger lift fastener knob and the fingerlift assembly.
2. Remove the finger lift fastener stud.
3. Push the saw guide bar up and out of the top of the head structure.
4. Remove the saw guide bar spring.
5. Clean and lubricate the babbitt pocket area (the square indented area that seats the saw guide bar spring).
6. Lower the new saw guide bar spring through the top of the babbitt pocket area and guide the spring into position with a standard screwdriver. (NOTE: Drawing)
7. While holding the saw guide bar spring in position, re-enter the saw guide bar from the top compressing the saw guide bar spring slightly until the saw guide bar slides past the spring.
8. Replace the finger lift fastener stud, the finger lift assembly and the finger lift fastener knob.
9. Test by making several adjustments.

- E. **STATIONARY BAR ASSEMBLY:** Check condition of nylon filler (Part No. 177), change every four (4) weeks. Check condition of saw guide (Part No. 119A), check tracking of blade through guide, back of blade should be centered in hole, replace every six (6) months. Check condition of lower blade back-up guide (Part No. 605). Check adjustment of back-up guide, should have $\frac{1}{32}$ " gap between back of blade and saw guide carbide. Replace every six (6) months.
- F. **SAW CLEANERS:** Check condition of blade cleaners, replace every four (4) weeks.
- G. **RATCHET ASSEMBLY:** Check for smooth operation through full range of travel. Check condition of trigger spring, replace as necessary.
- H. **SLIDE GIBS:** Check that the head structure moves freely up and down. Check for side to side and fore to aft tolerance. Adjust as required. Grease every four (4) weeks.
- I. **MEAT GAUGE ASSEMBLY:** Check free movement of meat gauge plate on gear rack. Gear rack to be kept lubricated at all times with light food grade oil. Check operation of release handle. Check that worm gear engages properly with gear rack.
- J. **MEAT CARRIAGE ASSEMBLY:** Check for free movement through full range of travel. Check for side to side tolerance, adjust as necessary. Check condition of bearings, replace as necessary. Check condition of thumb guard, replace as necessary.
- K. **SAFETY ITEMS:** Safety end cut pusher plate is with machine and accessible. All warning labels are present, properly affixed and legible. Model and Serial Number plate properly affixed and legible. Wall poster within operator's view from machine. Manual accessible to operator.

B. LUBRICATION

1. **UPPER WHEEL BEARINGS:** Grease every four (4) months. Change grease every twelve (12) months.
2. **LOWER BEARING HOUSING:** Grease every four (4) months. Change grease every twelve (12) months.
3. **SLIDE GIBS:** Grease every four (4) weeks.
4. **MEAT CARRIAGE BEARINGS:** Grease every four (4) weeks.
5. **SAW GUIDE BAR:** Oil daily with food machine oil.
6. **MEAT GAUGE GEAR RACK:** Oil daily with food machine oil.

— NOTE —
**USE SHELL CASSIDA
 GREASE EPS-2**

7. **MOTOR BEARINGS** — Bearing grease will lose its lubricating ability over time, not suddenly. The lubricating ability of a grease (over time) depends primarily on the type of grease, the size of the bearing, the speed at which the bearing operates and the severity of the operating conditions. Good results can be obtained if the following recommendations are used in your maintenance program.

A high grade ball or roller bearing grease should be used. Recommended grease for standard service conditions is Polyrex EM (Exxon Mobil).

Equivalent and compatible greases include:

Texaco Polystar, Rykon Premium #2, Pennzoil Pen 2 Lube, and Chevorn SRI.

Recommended lubrications intervals is every 9 months with the equivalent of two (2) teaspoons of grease.

SEE INSTRUCTIONS BELOW

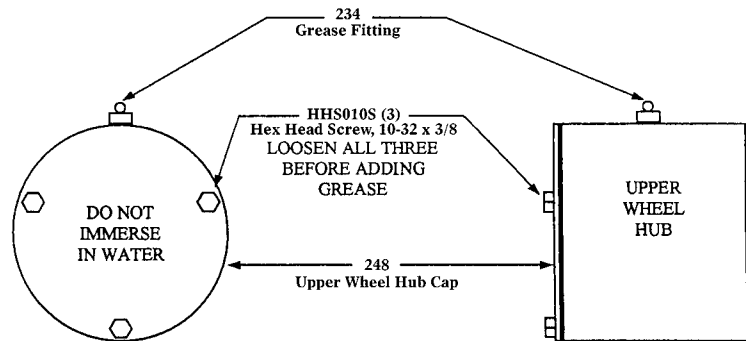

When lubricating the upper wheel bearing it is important that the three hex head screws securing the upper wheel hub cap be loosened slightly before attempting to pump grease into the grease fitting. Loosening the screws allows for an escape of old broken down grease and air from the bearing cavity. Failure to loosen the screws before greasing the upper bearings can cause the upper shaft seal to be dislodged from the upper wheel allowing grease to escape and moisture to get into the cavity. When finished greasing the bearings, retighten the three screws. Take care to also clean off any grease that was pushed out of the cavity during greasing.

C. SAW GUIDE BAR AND SAW GUARD

The factory recommends that when service is performed on any BIRO SAW the servicing agency be sure that the BIRO SAW is equipped with the most current safety features available.

MODEL 44 SAW GUIDE BARS AND SAW GUARDS

Production of the BIRO Model 44 began March 1956. All units prior to serial #4511 were equipped with a (round) cast aluminum head. The saw guide bar measured 21½" and the (Item #255) SAW GUARD was the same as used on Models 33 and 34.

The factory recommends that on all units equipped with (round) cast aluminum heads, the complete head assembly be replaced with the current stainless steel (fabricated square) HEAD ASSEMBLY (Item #AS18005).

All units serial #4511 on were built with a fabricated (square) steel head. The saw guide bar on these units measured 27" and is current. All units serial #4511 on are equipped with the most current safety features.

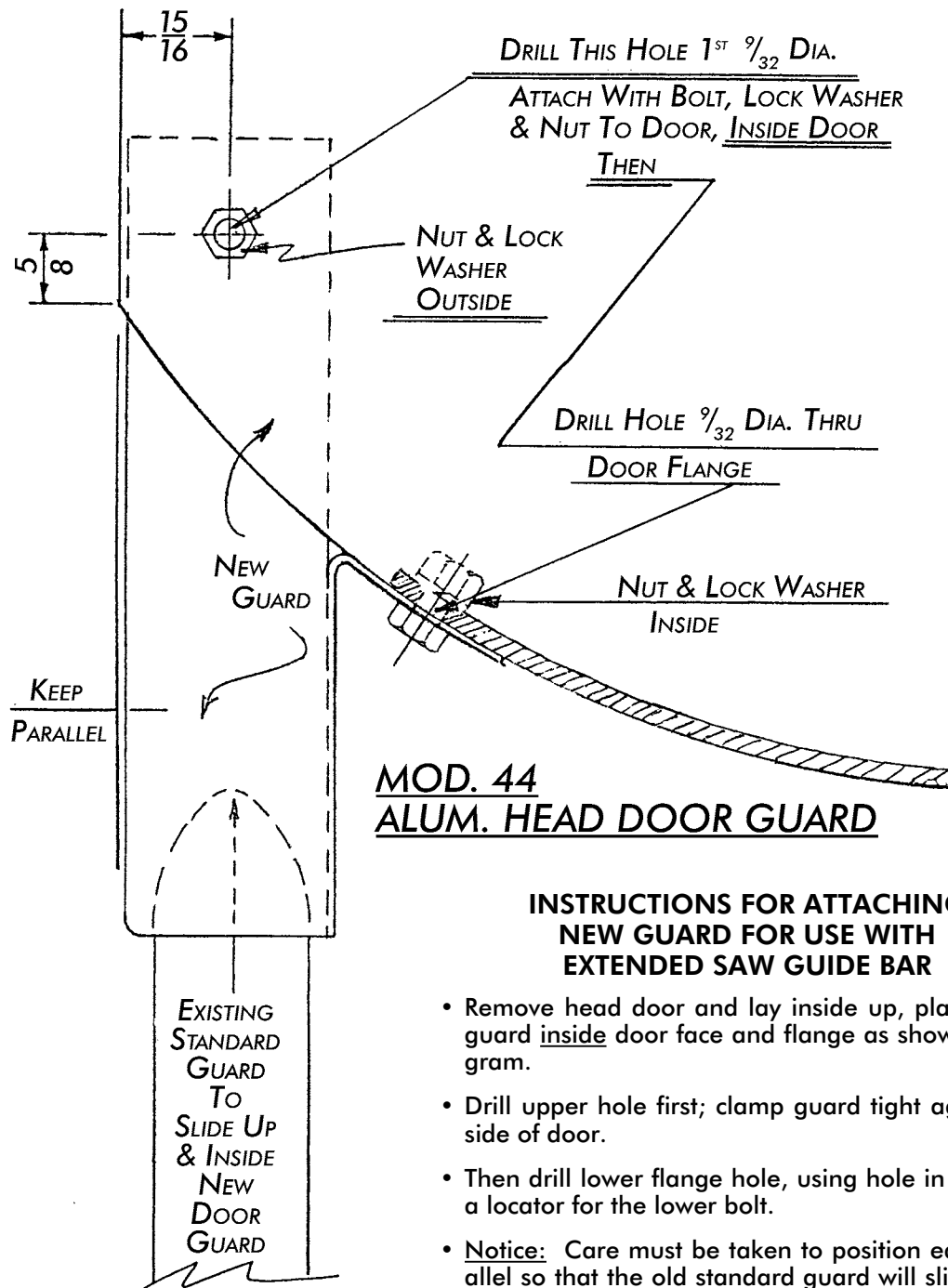

- Remove head door and lay inside up, placing new guard inside door face and flange as shown in diagram.
- Drill upper hole first; clamp guard tight against inside of door.
- Then drill lower flange hole, using hole in guard as a locator for the lower bolt.
- **Notice:** Care must be taken to position edges parallel so that the old standard guard will slide up inside the new guard.

NOTE:
ALWAYS REPORT MACHINE
SERIAL NUMBER WHEN
ORDERING PARTS

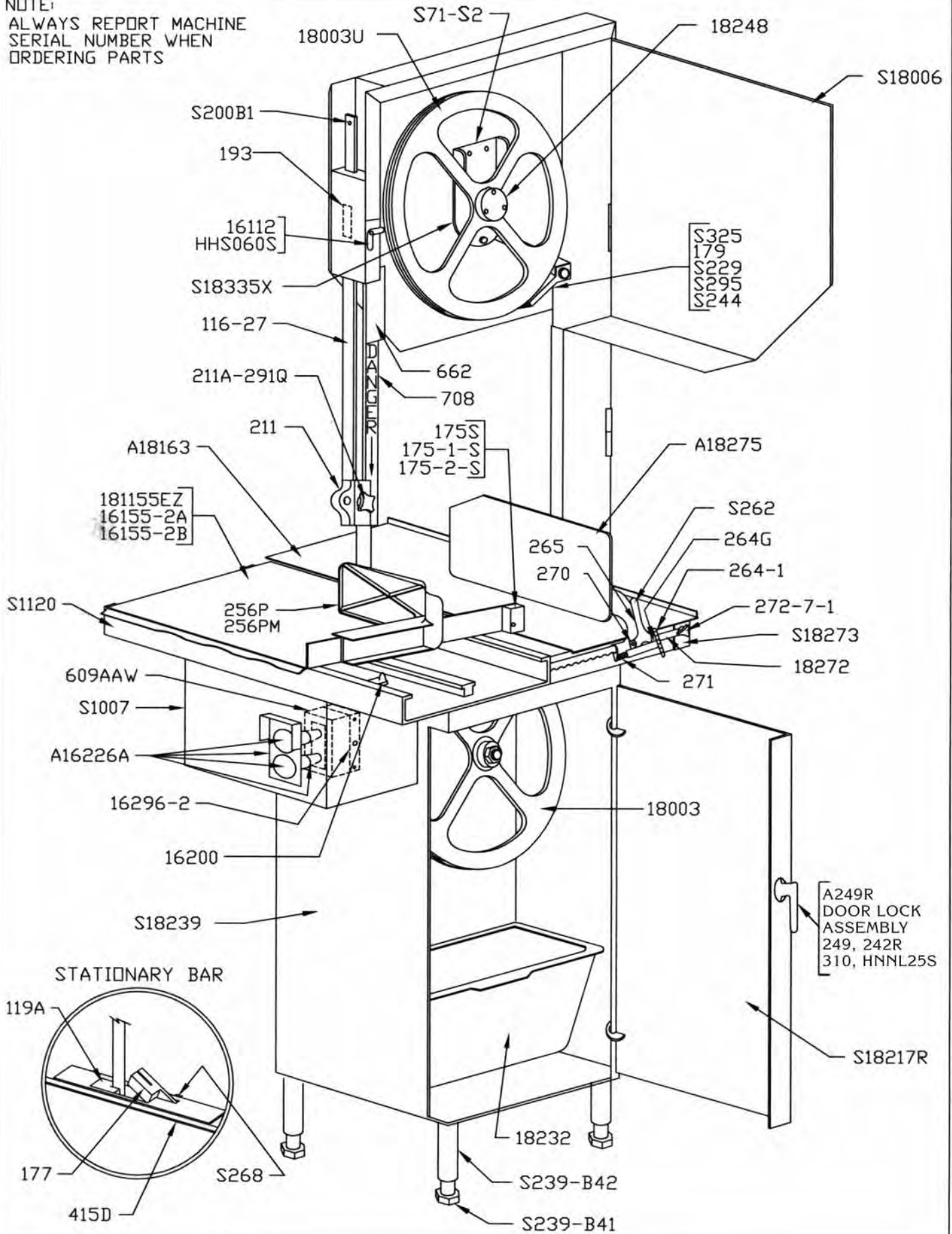

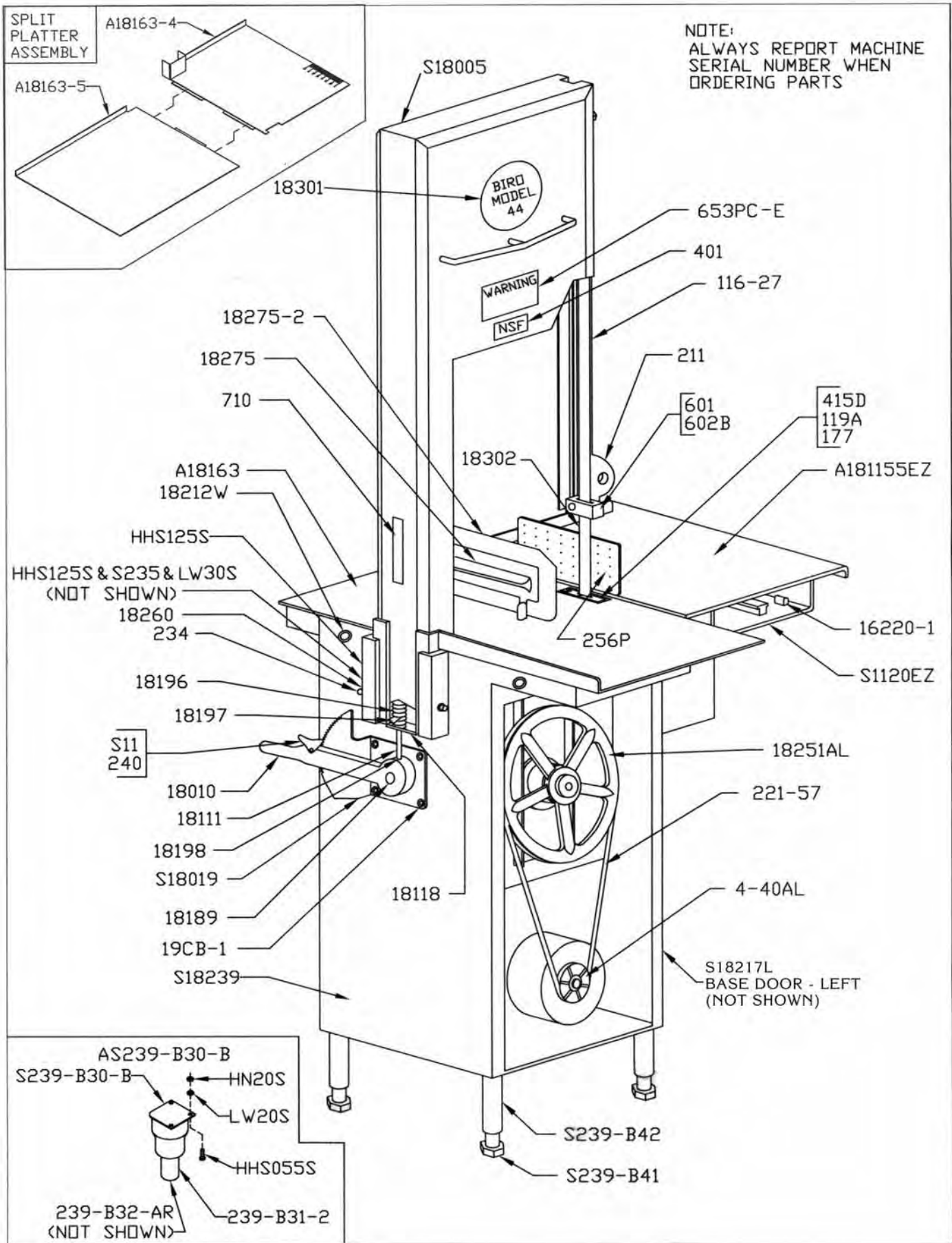

AS18005 S.S. HEAD & DOOR ASSEMBLY

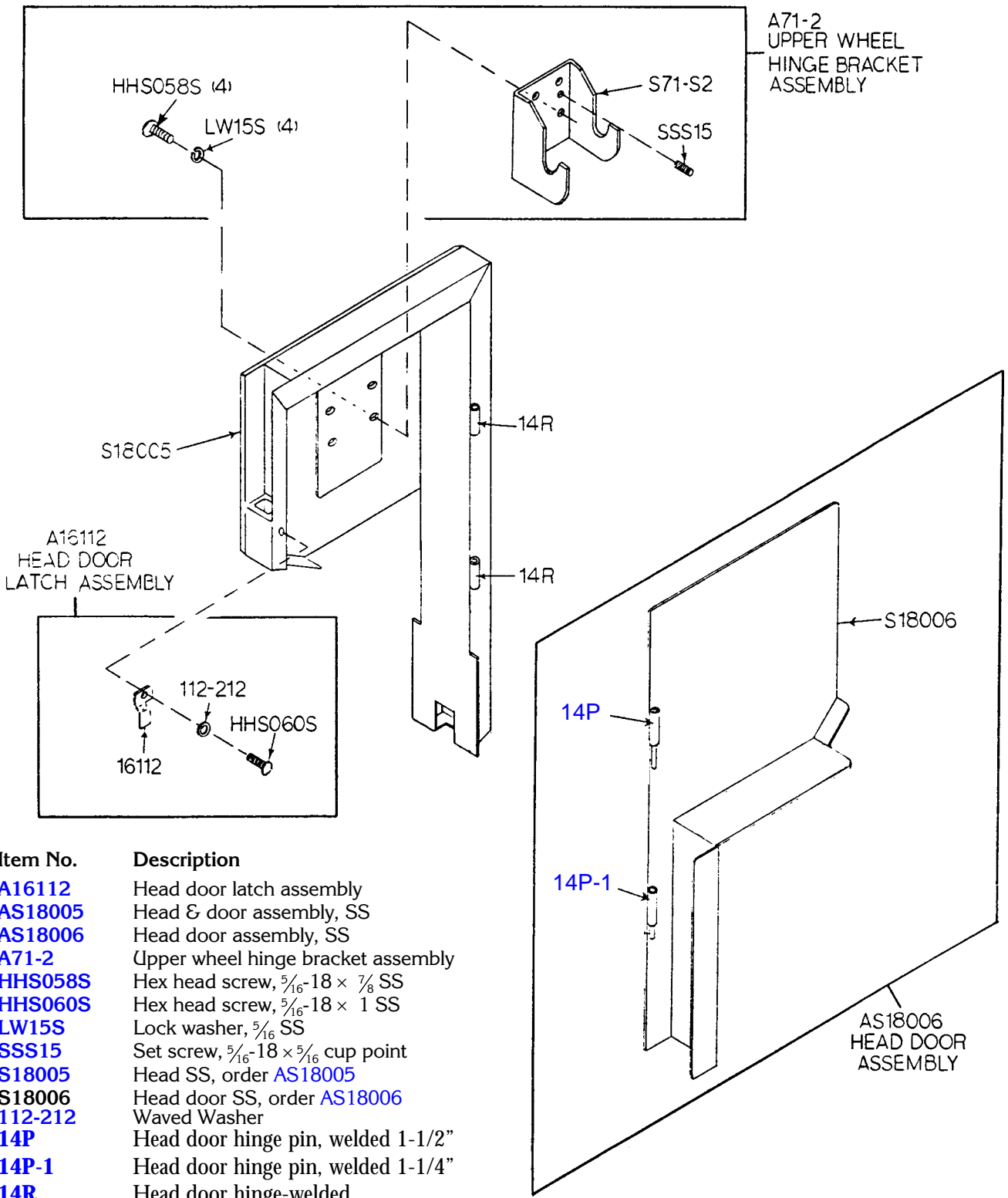

Item No.	Description
A16112	Head door latch assembly
AS18005	Head & door assembly, SS
AS18006	Head door assembly, SS
A71-2	Upper wheel hinge bracket assembly
HHS058S	Hex head screw, $\frac{5}{16}$ -18 x $\frac{7}{8}$ SS
HHS060S	Hex head screw, $\frac{5}{16}$ -18 x 1 SS
LW15S	Lock washer, $\frac{5}{16}$ SS
SSS15	Set screw, $\frac{5}{16}$ -18 x $\frac{5}{16}$ cup point
S18005	Head SS, order AS18005
S18006	Head door SS, order AS18006
112-212	Waved Washer
14P	Head door hinge pin, welded 1-1/2"
14P-1	Head door hinge pin, welded 1-1/4"
14R	Head door hinge-welded
16112	Head door latch
71-2	Upper wheel hinge bracket

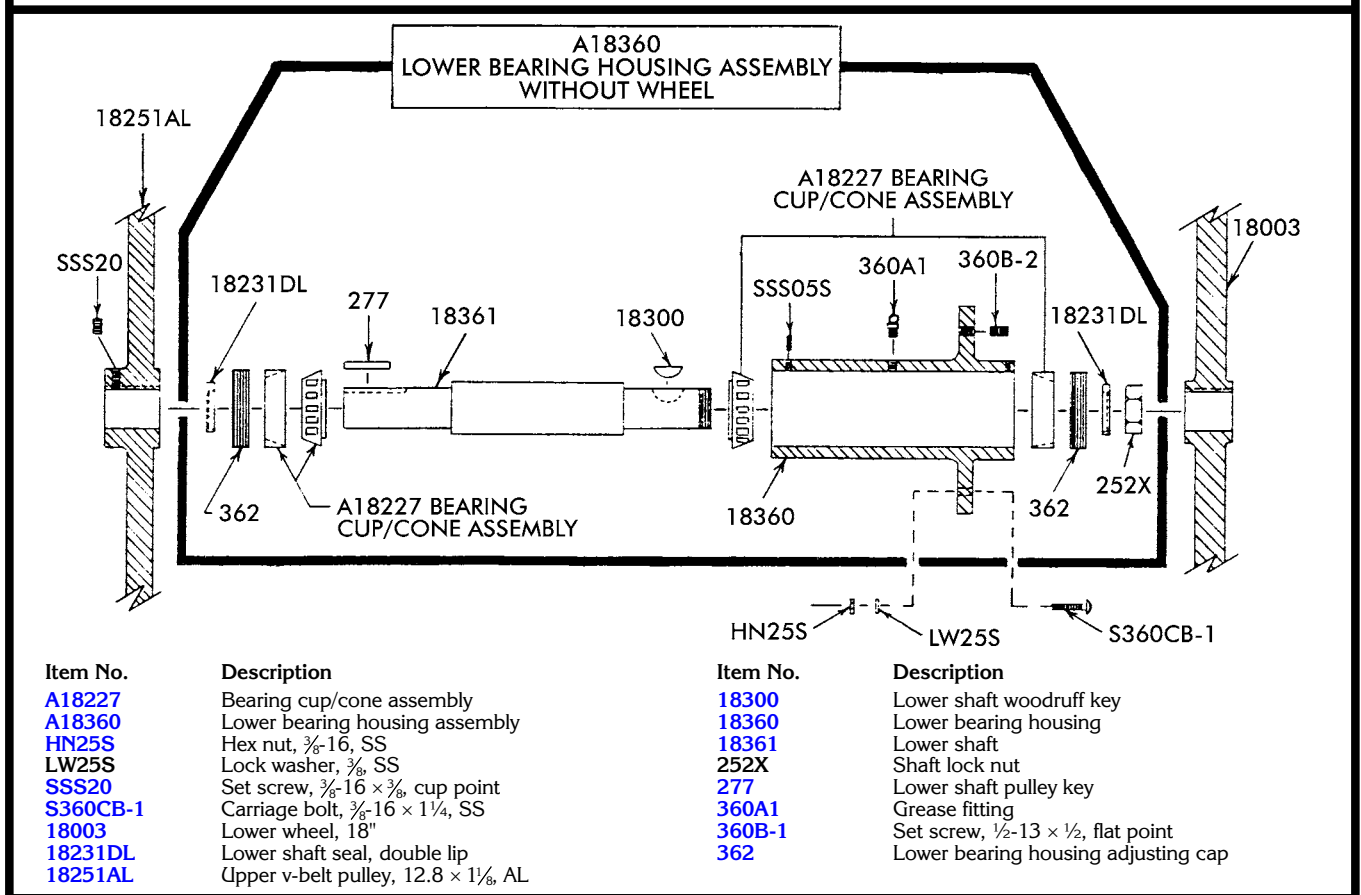
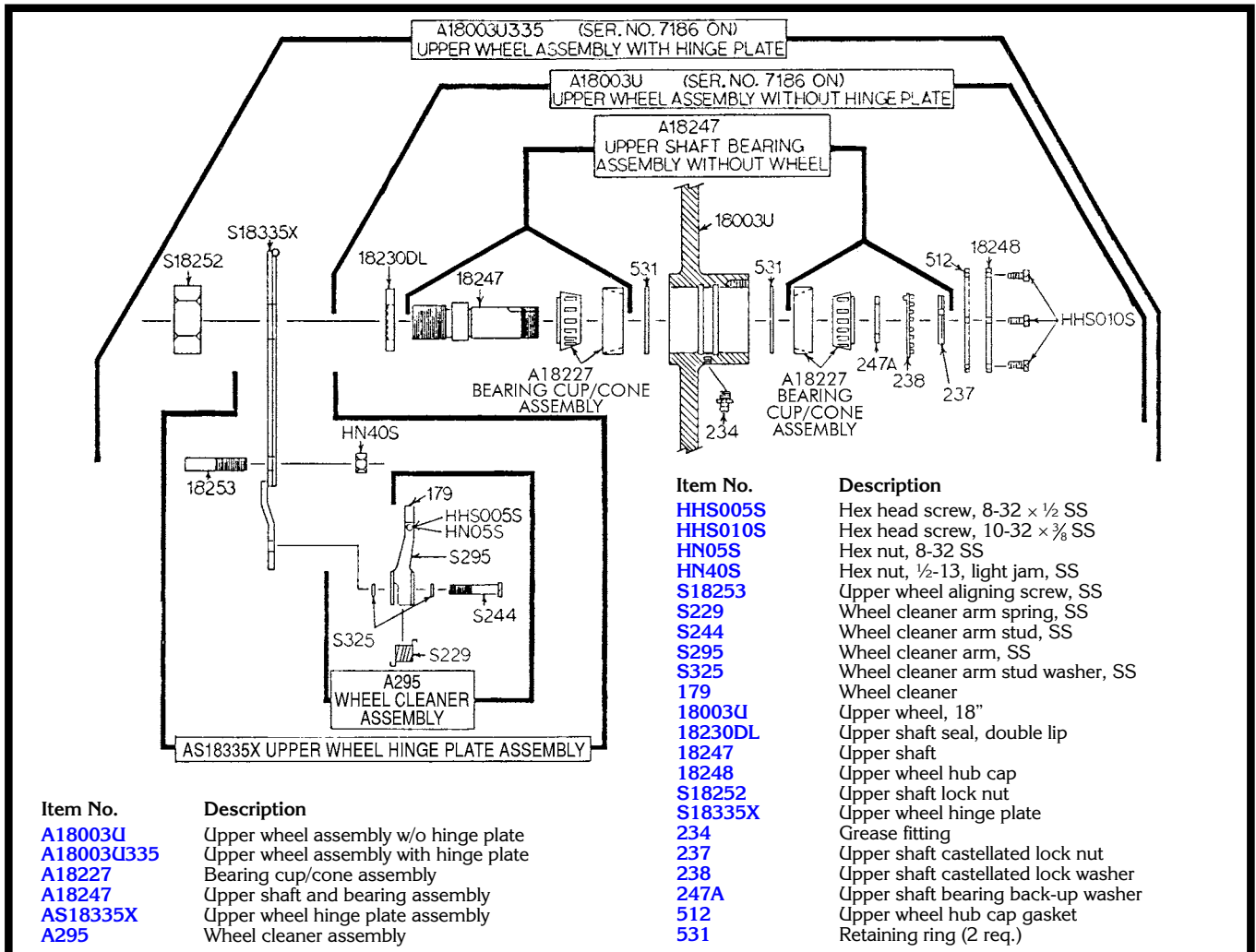

**AS18019
RATCHET ASSEMBLY**

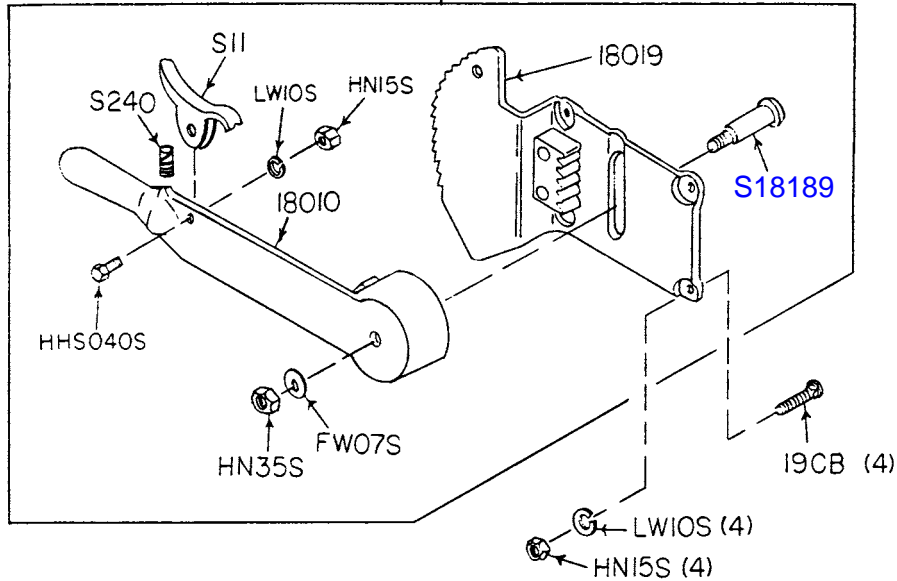

Item No.
AS18019
FW07S
HHS040S
HN15S
HN35S
LW10S

Description
 Ratchet assembly
 Flat washer, 3/8 SS
 Hex head screw, 1/4-20 x 3/4 SS
 Hex nut, 1/4-20 SS
 Hex nut, 3/8-16 SS
 Lock washer, 1/4 SS

S11
S18189
S240
18010
18019
19CB

Description
 Ratchet trigger SS
 Ratchet arm stud SS
 Ratchet trigger spring, SS
 Ratchet arm
 Ratchet base
 Carriage bolt 1/4-20 x 3/4 SS

**A18273-275 MEAT GAUGE
GEAR RACK & BRACKET ASSEMBLY**

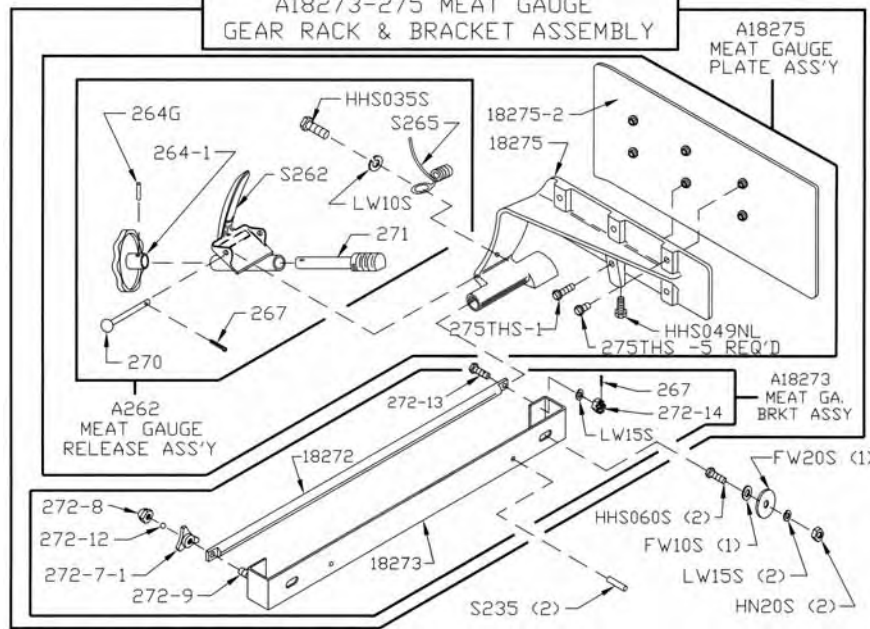

Item No.
A18273-275
A18273
A18275
A262
FW10S
HHS035S
HHS040S
HHS049NL
HHS060S
HN20S
LW10S
LW15S
S235
S262
S265
S18272

Description
 NOT SOLD AS ASSEMBLY
 Meat gauge bracket assembly
 Meat gauge plate assembly
 Meat gauge release assembly
 Flat washer, 3/16 SS
 Hex head screw 1/4-20 x 5/8 SS
 Hex head screw, 1/4-20 x 3/4, SS
 Hex screw - nylon 5/16-18 x 1/2 lg.
 Hex head screw, 5/16-18 x 1, SS
 Hex nut, 3/8-18, SS
 Lock washer, 1/4 SS
 Lock washer, 3/16 SS
 Taper pin, 4 x 3/4 SS
 Meat gauge release handle, SS
 Meat gauge release spring, SS
 Meat gauge gear rack

Item No.
18273
18275
18275-2
264G
264-1
264-1S
267
270
271AL
272-7-1
272-8
272-9
272-12
272-13
275THS
275THS-1

Description
 Meat gauge bracket, ORDER **A18273**
 Meat gauge arm
 Meat gauge plate, SS
 Meat gauge hand wheel groove pin
 Meat gauge hand wheel
 Hand wheel shim
 Meat gauge release cotter key
 Meat gauge release pin
 Meat gauge worm gear
 Lock knob, 5/16-18, 3 point
 Cap nut 5/16-18 SS
 Hex head screw, 5/16-18 x 2, SS
 Brass ball, 1/2 dia.
 Hex head bolt, 5/16-18 x 1 1/4, SS
 Truss head screw, 1/4-20 x 3/8 (5 ea.)
 Truss head screw, 1/4-20 x 1 (1 ea.)

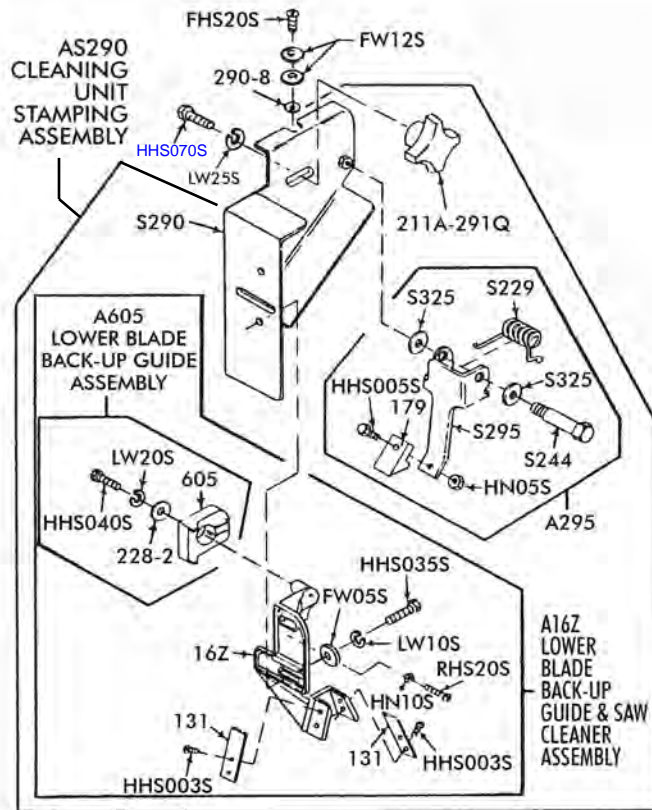

Item No.	Description
A16Z	Guide bracket saw cleaner assembly
A295	Wheel cleaner assembly
A605	Lower blade backup guide assembly
AS290	Cleaning unit stamping assembly
FHS20S	Flat head screw, 10-32 x 1/2, SS
FW05S	Flat washer, 1/4, SS
HHS003S	Hex head screw, 8-32 x 1/4, SS
HHS005S	Hex head screw, 8-32 x 1/2, SS
HHS035S	Hex head screw, 1/4-20 x 3/8, SS
HHS040S	Hex head screw, 1/4-20 x 3/4, SS
HHS070S	Hex head screw, 3/8-16 x 1, SS
HN05S	Hex nut, 8-32, SS
HN10S	Hex nut, 10-32, SS
LW10S	Lock washer, 1/4, SS
LW25S	Lock washer, 3/8, SS
RHS20S	Round head screw, 10-32 x 1 1/4, SS
S229	Wheel cleaner arm spring, SS
S244	Wheel cleaner arm stud, SS
S290	Cleaning unit stamping, SS
S295	Wheel cleaner arm, SS
S325	Wheel cleaner washer, SS
131	Saw cleaner, SS
16Z	Lower guide bracket saw cleaner holder
179	Wheel cleaner
211A-291Q	Fastener knob, 4 point
228-2	Lower guide washer
290-8	Cleaning unit locator washer, SS
605	Saw guide lower blade backup

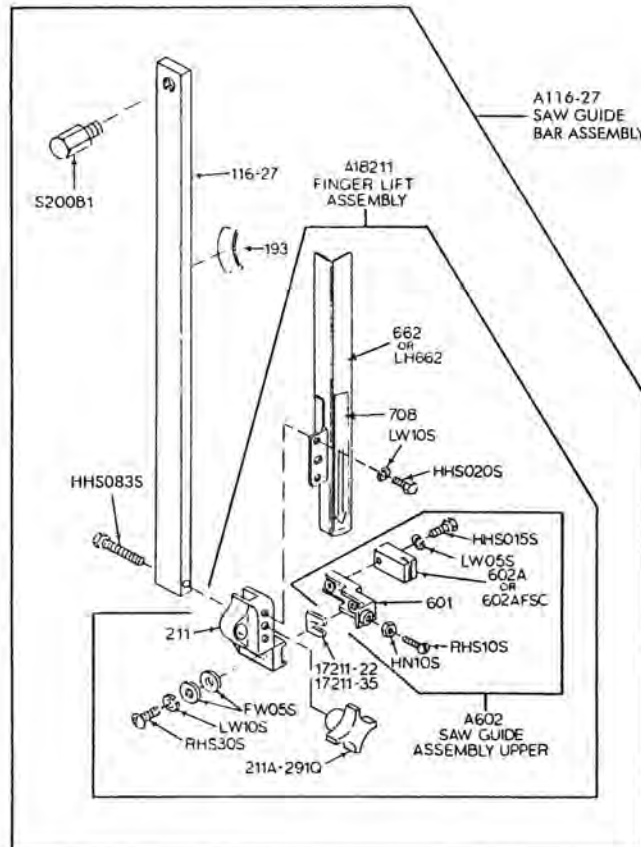

Item No.	Description
A116-27	Saw guide bar assembly, 27"
A18211	Finger lift assembly, removable
A602	Saw guide assembly, upper
FW05S	Flat washer, 1/4, SS
HHS015S	Hex head screw, 10-32 x 7/8, SS
HHS020S	Hex head screw, 1/4-20 x 3/8, SS
HHS083S	Hex head screw 3/8-16 x 1 3/4, SS
HN10S	Hex nut, 10-32, SS
LH662	Saw guard for true left head
LW05S	Lock washer, #10, SS
LW10S	Lock washer, 1/4, SS
RHS10S	Round head screw, 10-32 x 3/4, SS
RHS30S	Round head screw, 1/4-20 x 3/8, SS
S200B1	Stop stud on guide bar
116-27	Saw guide bar, 27"
17211-22	Finger lift shim, .022
17211-35	Finger lift shim, .035
193	Saw guide bar spring
211	Finger lift bracket
211A-291Q	Fastener knob, 4 point
601	Upper saw guide bracket
602B	Upper saw guide
602AFSC	Upper saw guide, narrow, fish
662	Saw guard for stainless head, SS
663	Saw guard for aluminum head, SS
708	Decal "DANGER EXPOSED BLADE"

A415D OR AS415D
STATIONARY BAR ASSEMBLY

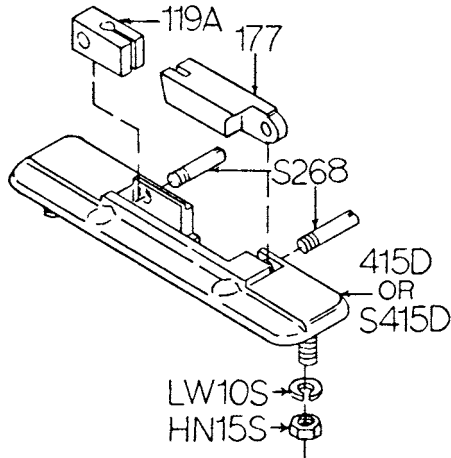

Item No.	Description
A415D	Stationary bar assembly
AS415D	SS Stationary bar assembly
HHS035S	Hex head screw, 1/4-20 x 3/8, SS
HN15S	Hex nut, 1/4-20, SS
LW10S	Lock washer, 1/4, SS
S268	Stationary bar headless screw
S415D	Stainless stationary bar
119A	Saw guide in stationary bar
119FSC	Saw guide in sta. bar, fish
177	Nylon filler
415D	Stationary bar

A16132 REAR STEEL CLEANER ASSEMBLY

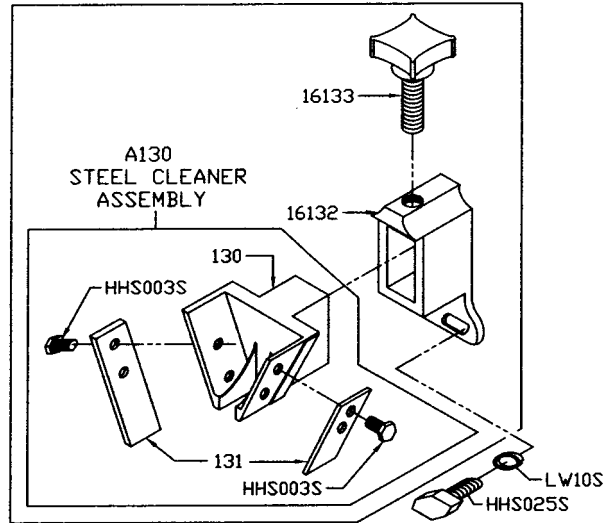

Item No.	Description
A130	Saw cleaner assembly
A16132	Steel cleaner assembly, rear
HHS003S	Hex head screw, 8-32 x 1/4, SS
HHS025S	Hex head screw, 1/4-20 x 1, SS
130	Saw cleaner bracket, rear
131	Saw cleaner, SS
16132	Saw cleaner bracket holder, rear
16133	Locking knob

A18196
TENSION
SPRING
ASSEMBLY

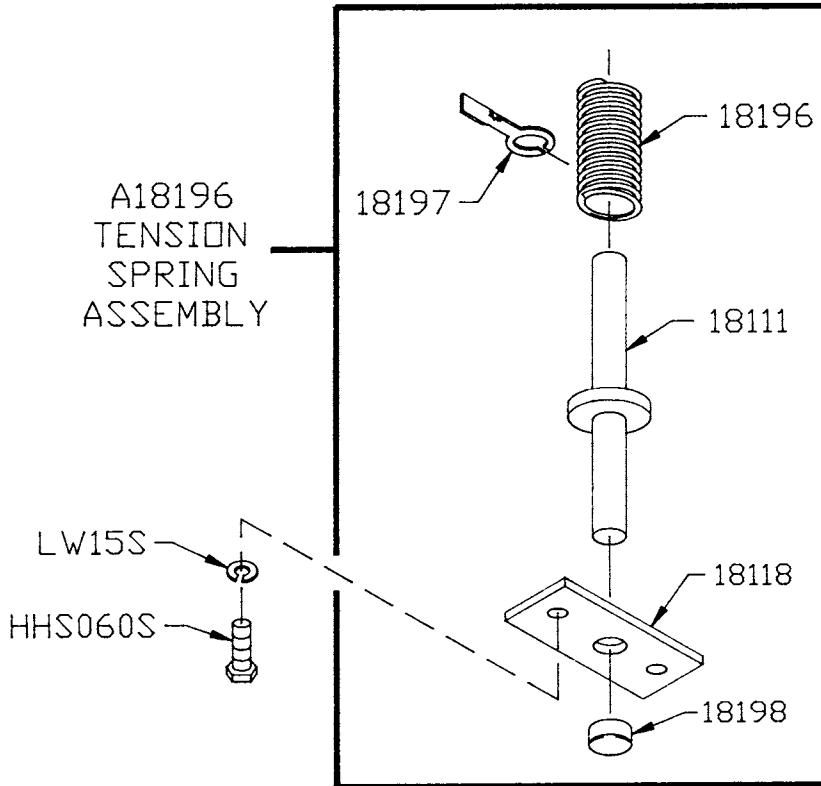

Item No.	Description
A18196	Tension spring assembly
HHS060S	Hex head screw, 5/16-18 x 1, SS
LW15S	Lock washer, 5/16, SS
18111	Tension spring pin
18118	Tension spring plate
18196	Saw tension spring
18197	Tension spring gauge
18198	Cap for tension pin

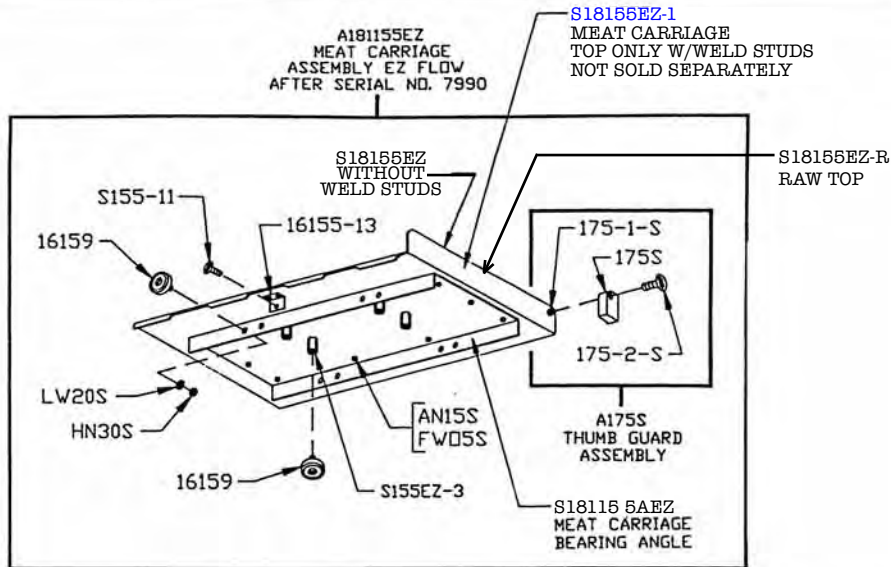

Item No.	Description
A175S	Thumb guard assembly
A181155EZ	Meat carriage assembly, EZ Flow
AN15S	Acorn nut, 1/4-20
FW05S	Flat washer, 1/4
HN30S	Hex nut, 3/8-16 light jam
LW20S	Lock washer, light
S155-11	Carriage stop thumb screw
S155EZ-1	Weld stud - NSS
S155EZ-2	Weld stud - NSS

Item No.	Description
S181155AEZ	Carriage bearing angle plate
S18155EZ-1	Carriage top w/weld studs
S18155EZ	Carriage top without weld studs (DNS)
S18155EZ-R	Raw meat carriage top only (DNS)
S155EZ-3	Hex stand-off
16155-13	Carriage top angle SS
16159	Carriage bearing
175S	Thumb guard
175-1-S	Thumb guard nut
175-2-S	Thumb screw 1/4-20 x 1/2

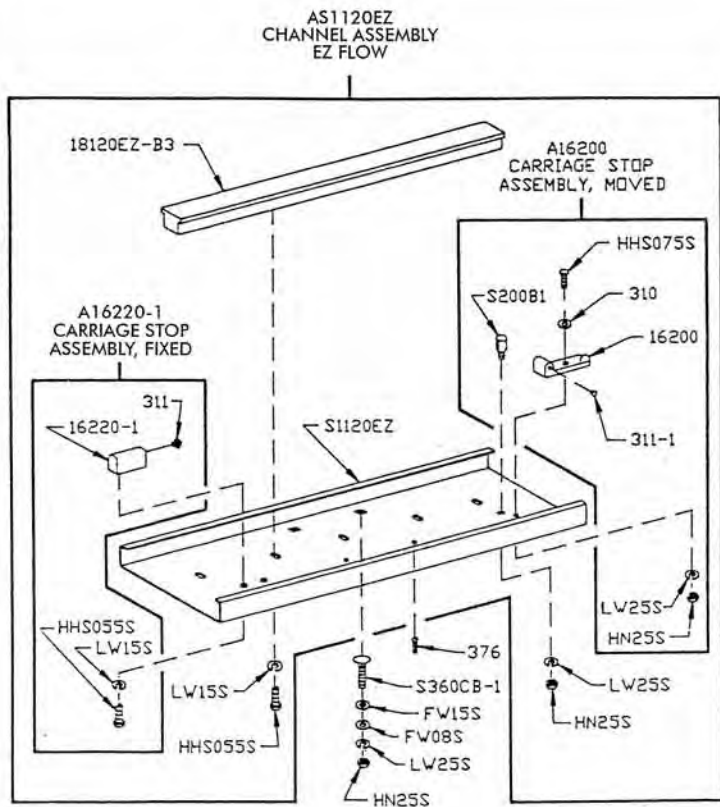

Item No.	Description
A16200	Carriage stop assembly, movable
A16220-1	Carriage stop assembly, fixed
AS1120EZ	Channel assembly, EZ flow
FW08S	Flat washer, 3/8, SS
FW15S	Flat washer, 1/2, SS
HHS055S	Hex head screw, 5/16-18 x 3/4, SS
HHS075S	Hex head screw, 3/8-16 x 1 1/4, SS
HN20S	Hex nut, 5/16-18, SS
HN25S	Hex nut 3/8-16, SS
LW15S	Lock washer, 5/16, SS
LW25S	Lock washer, 3/8, SS
S1120EZ	Channel, 38-1/2", SS
S200B1	Carriage stop stud, SS
S360CB-1	Carriage bolt, 3/8-16 x 1 1/4, SS
16200	Carriage stop only, movable
16220-1	Carriage stop only, fixed
18120EZ-B3	Guide bar, EZ flow, T-shaped
310	Waved washer
311	Rubber bumper for fixed stop
311-1	Rubber bumper for movable stop
376	Drive screw, 10 x 1/2, SS

LONGER SAW GUARD KIT ITEM NO. 662K

This longer guard is available for replacement as a kit on existing saws. Install the new guard with the 1/4" dia. screws supplied with Saw Guard Kit, Item No. 662K.

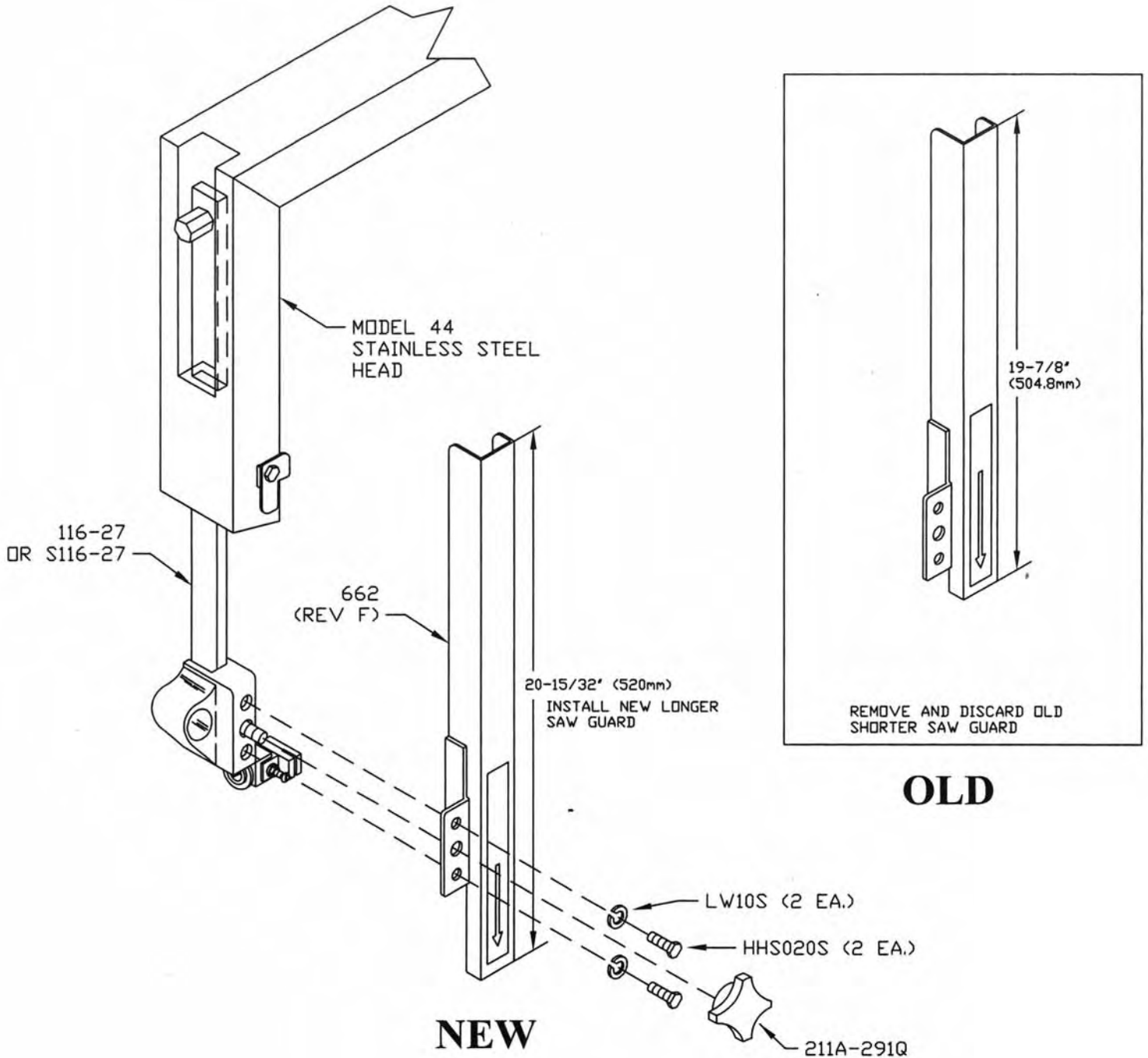

- OPERATORS NOTES -

A609AAW-18 SWITCH ASSEMBLY

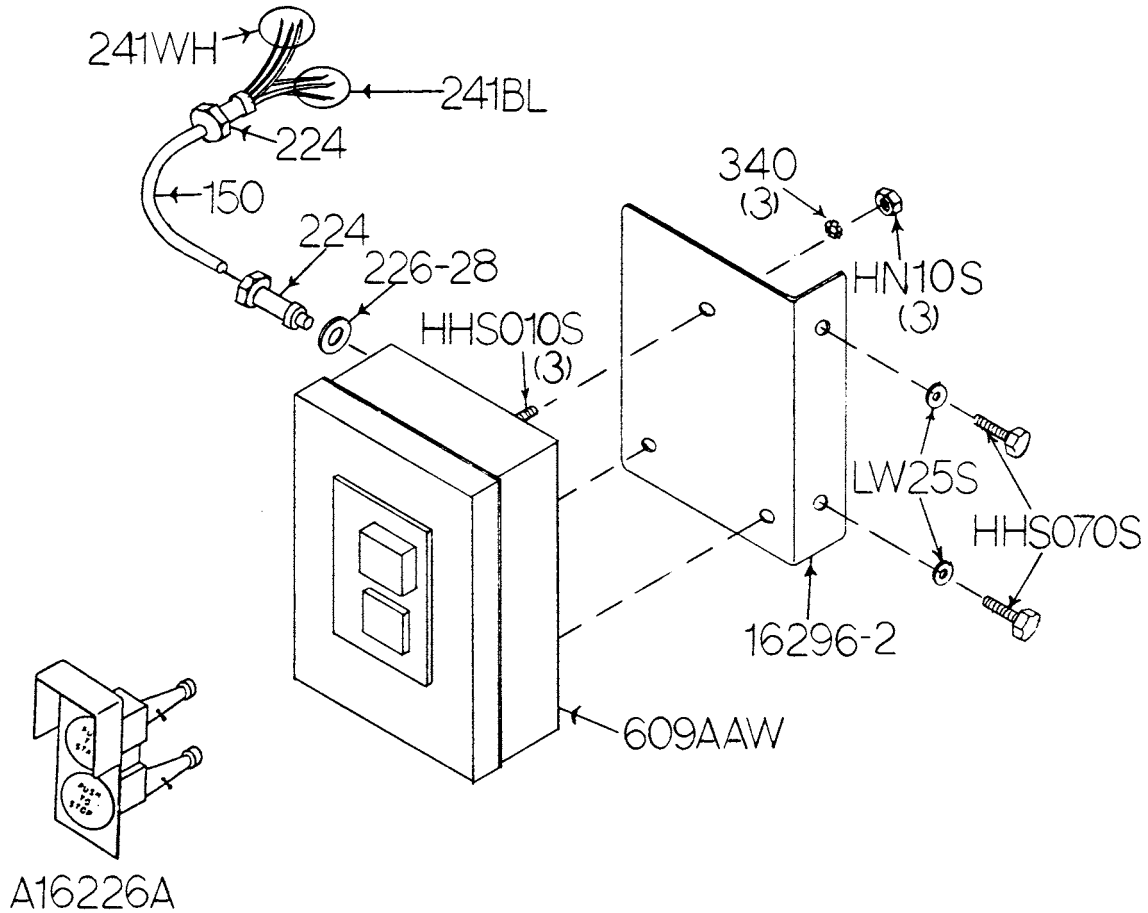

A16226A

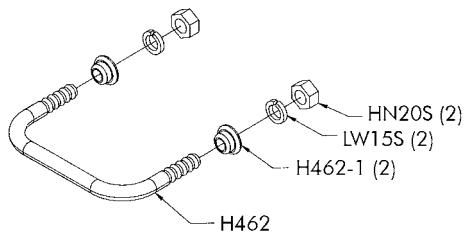

H462A

Item No.

A16226A
A609AAW-16
H462A
HHS010S
HHS070S
HN10S
HN20S
LW25S
16296-2
150
224
226-28
241BL
241WH
340
609AAW

Description

Green/red switch button assembly w/springs
 Switch assembly, 1 & 3 ph less heater coils
 Guard assembly for switch
 Hex head screw, 10-32 x 3/8 SS
 Hex head screw, 3/8-16 x 1 SS
 Hex nut, 10-32 SS
 Hex nut 5/16-18 SS
 Lock washer, 3/8 SS
 Switch bracket SS
 Conduit, 1/2"
 Conduit connector, 180°
 Washer SS, 1/2 x 27/32
 Wire, black, 12GA., CSA & UL
 Wire, white, 12GA., CSA & UL
 Star lock washer
 Manual switch, size 0, 1 & 3 ph

609AAW

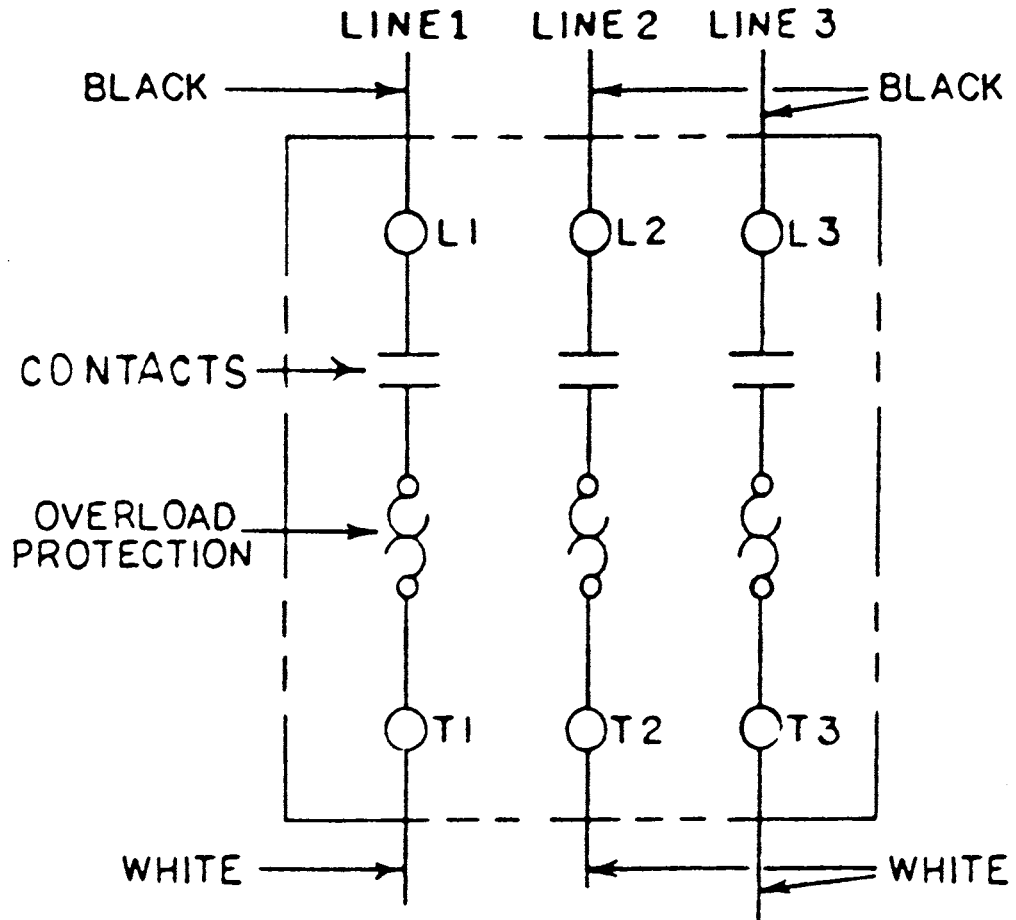

WATERTIGHT MAGNETIC SWITCH ASSEMBLIES

INCLUDES MOUNTING BRACKET AND WIRES

Item No.	Description	Application
A22618EE-522	BAEG/PC-PB/C14	3HP, 208-220-50/60-3
A22618EE-534	BAEG/MS-PB/05-E6.3	3HP, 440/460-60-3
A22618EE-536	BAEG/MS-PB/05-D8	3HP, 380/415-50-3
A22618EE-538	BAEG/MS-PB/05-F4.7	3HP, 550/575-60-3
A22618EE-540	BAEG/MS-PB/C18	5HP, 208/230-50/60-3
A22618EE-544	BAEG/MS-PB/05-E8	5HP, 440/460-60-3
A22618EE-546	BAEG/MS-PB/05-D14	5HP, 380/415-50-3
A22618EE-548	BAEG/MS-PB/05-F8	5HP, 550/575-60-3

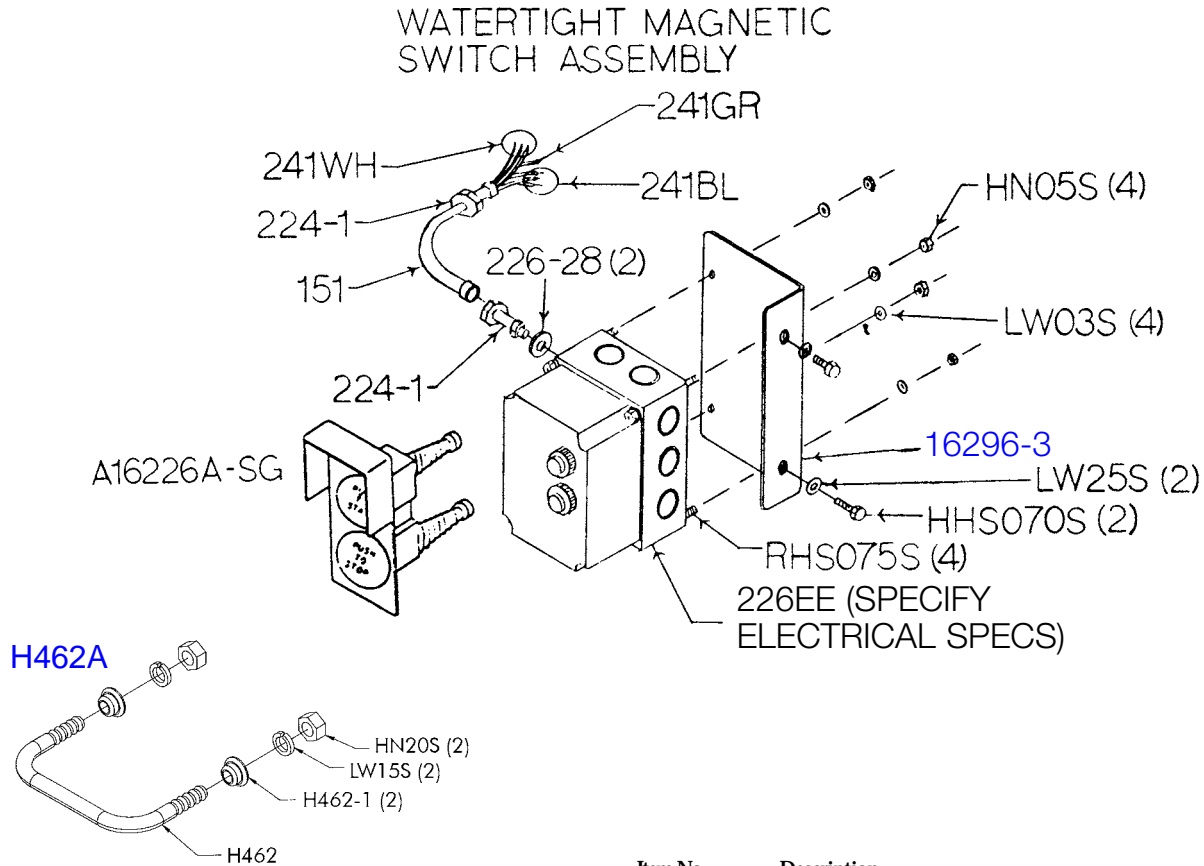

Item No.	Description
A16226A-SG	GREEN/RED SWITCH BUTTON ASSEMBLY
H462A	GUARD ASSEMBLY FOR SWITCH
HHS070S	HEX HEAD SCREW, 3/8 - 16 x 1 SS
HN05S	HEX NUT, 8-32 SS
LW03S	LOCK WASHER, #8 SS
LW25S	LOCK WASHER, 3/8 HEAVY SS
RHS075S	ROUND HEAD SCREW, 8-32 x 3/4 SS
16296-3	SWITCH BRACKET SS, AEG/VYNCKIER ENCLOSURE
151	WATERTIGHT CONDUIT
224-1	CONDUIT CONNECTOR, WT 180°
226EE-522	BAEG/MS-PB/05-C14 3HP 230-50/60-3
226EE-522K	CONTACTOR, OVERLOAD, SUBPLATE REPLCMNT 220V, 3PH, 3HP
226EE-534	BAEG/MS-PB/05-E6.3 3HP 440-60-3
226EE-534K	CONTACTOR, OVERLOAD, SUBPLATE REPLCMNT 440V, 3PH, 3HP
226EE-536	BAEG/MS-PB/05-D8 3HP, 380-50-3
226EE-536K	CONTACTOR, OVERLOAD, SUBPLATE REPLCMNT 380V, 3PH, 3HP
226EE-538	BAEG/PC-PB/05-F4.7 3HP 550-60-3
226EE-538K	CONTACTOR, OVERLOAD, SUBPLATE REPLCMNT 550V, 3PH, 3HP
226EE-539	BAEG/PC-PB/05-A4.7 3HP 550-110-60-3
226EE-540	BAEG/MS-PB/C18 5HP 220-60-3
226EE-540K	CONTACTOR, OVERLOAD, SUBPLATE REPLCMNT 220V, 3PH, 5HP
226EE-544	BAEG/MS-PB/05-E8 5HP 440-60-3
226EE-544K	CONTACTOR, OVERLOAD, SUBPLATE REPLCMNT 440V, 3PH, 5HP

Item No.	Description
226EE-546	BAEG/MS-PB/D14 5HP 380/415-50-3
226EE-546K	CONTACTOR, OVERLOAD, SUBPLATE REPLCMNT 380V, 3PH, 5HP
226EE-548	BAEG/MS-PB/05-F8 5HP, 550-60-3
226EE-548K	CONTACTOR, OVERLOAD, SUBPLATE REPLCMNT 550V, 3PH, 5HP
226EE-CO	CONTACTOR, LS05.10-CO, 208-230V
226EE-CO11K	CONTACTOR, LS11K.11S-CO, 208-230V
226EE-DO	CONTACTOR, LS05.10-DO, 380-415V
226EE-ENCL-PB30	ENCLOSURE WITH PUSHBUTTON 30MM HOLES
226EE-EO	CONTACTOR, LS05.10-EO 440-480V
226EE-EO11K	CONTACTOR, LS11K.11S-EO 480V, 60HZ-380V, 50HZ
226EE-FO	CONTACTOR, LS05.10-FO, 550V
226EE-FO11K	CONTACTOR, LS11K.11S-FO, 575V
226EE-OL06.3K	OVERLOAD B05-K, 4-6.3A
226EE-OL08.5L	OVERLOAD B18K-L, 5.5-8.5A
226EE-OL08L	OVERLOAD B05-L, 5.5-8A
226EE-OL12M	OVERLOAD B18K-M, 8-12A
226EE-OL14NN	OVERLOAD B05-NN, 10-14A
226EE-OL18O	OVERLOAD B18K-O, 14.5-18A
226EE-OL4I	OVERLOAD B18K-I, 2.5-4A
H281EE-51	OVERLOAD B18K, 4-6.3A
226-28	WASHER, 1 1/2 x 27/32 SS
241BL	WIRE, BLACK 12 GA., CSA & UL
241GR	WIRE, GREEN, 12GA., CSA & UL
241RD	WIRE, RED, 12 GA., CSA & UL
241WH	WIRE, WHITE 12 GA., CSA & UL

**WEARABLE SAW PARTS THAT WILL FIT BIRO POWER CUTTERS
MODELS**

11-22-1433-33-34-3334-44-4436-55

— EXCEPT WHERE NOTED OTHERWISE —

**CONTACT YOUR NEAREST BIRO AUTHORIZED DISTRIBUTOR
OR CONTACT BIRO MANUFACTURING**

PH: 419-798-4451 E-Mail: service@birosaw.com



**Item No. 130
SAW CLEANER BRACKET
ALL SAWS**

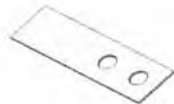

**Item No. 131
STEEL BLADE CLEANER
ALL SAWS**



**Item No. 159
CARRIAGE BEARING
11-22-33**



**Item No. 16159
CARRIAGE BEARING
1433-34-3334-44-55**



**Item No. 601
UPPER SAW GUIDE BRACKET
ALL SAWS**



**Item No. 602B
UPPER SAW GUIDE
W/BEVELED CARBIDE
ALL SAWS**



**Item No. S265
MEAT GAUGE SPRING
ALL SAWS**



**Item No. S608
LOWER BLADE BACKUP
W/CARBIDE
22 (after S/N 35301)-1433-55**



**Item No. 119A
LOWER SAW GUIDE
ALL SAWS**



**Item No. 177
NYLON FILLER
ALL SAWS**



**Item No. 604
LOWER BLADE BACKUP
W/CARBIDE
11-22 (before S/N 35300)**



**Item No. 605
LOWER BLADE BACKUP
W/CARBIDE
34-3334-44-4436**



**Item No. S295
WHEEL CLEANER ARM
ALL SAWS**



**Item No. 179
WHEEL CLEANER
ALL SAWS**



**Item No. S244
WHEEL CLEANER ARM STUD
ALL SAWS**



**Item No. S229
WHEEL CLEANER
ARM SPRING
ALL SAWS**



**Item No. S268
FILLER & GUIDE STUD
ALL SAWS**

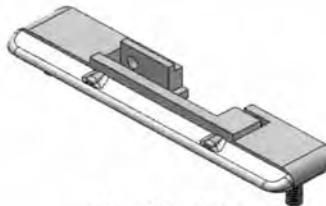

**Item No. 415D
STATIONARY BAR
ALL SAWS**

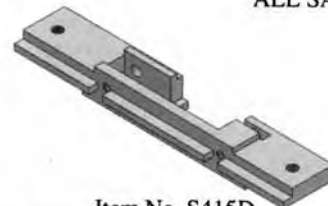

**Item No. S415D
STAINLESS STATIONARY BAR
STD: 22 (after S/N 35301)-1433-55
OPT: 3334-44**

— USE PARTS REPAIR KIT PART NO. 16700 —

MODEL 44 PARTS NUMBERS AND DESCRIPTIONS

SEND IN MODEL NO. AND SERIAL NO. WHEN ORDERING PARTS

MOTOR SECTION		Item No.	Description
<p>M79-G56111-U Motor, 3HP, 208/220/440-50/60-3 open M88-G56215-U Motor, 5HP, 220/440-60-3 moisture resistant M89-G56214-U Motor, 5HP, 575-60-3 moisture resistant</p> <p>Item No. AN15S Acorn nut, 1/4-20, SS FHS20S Flat head screw, 10-32 x 1/2, SS FW05S Flat washer, 1/4, SS FW07S Flat washer, 3/8, SS FW08S Flat washer, 3/8, SS FW10S Flat washer, 5/16, SS FW15S Flat washer, 1/2, SS HHS003S Hex head screw, 8-32 x 1/4 trim hd, SS HHS005S Hex head screw, 8-32 x 1/2, SS HHS010S Hex head screw, 10-32 x 3/8, SS HHS015S Hex head screw, 10-32 x 7/8, SS HHS020S Hex head screw, 1/4-20 x 5/8, SS HHS025S Hex head screw, 1/4-20 x 1, SS HHS035S Hex head screw, 1/4-20 x 5/8, SS HHS040S Hex head screw, 1/4-20 x 3/4, SS HHS049NL Hex screw – nylon 5/16-18 x 1/2 lg. HHS055S Hex head screw, 5/16-18 x 3/4, SS HHS058S Hex head screw, 5/16-18 x 7/8, SS HHS060S Hex head screw, 5/16-18 x 1, SS HHS070S Hex head screw, 3/8-16 x 1, SS HHS075S Hex head screw, 3/8-16 x 1, SS HN05S Hex nut, 8-32, SS HN10S Hex nut, 10-32, SS HN15S Hex nut, 1/4-20, SS HN20S Hex nut, 5/16-18, SS HN25S Hex nut, 3/8-16, SS HN30S Hex nut, 3/8-16 light jam, SS HN35S Hex nut, 3/8-16 heavy jam, SS HN40S Hex nut, 1/2-13 heavy jam, SS LH662 Saw guard for true left SS head LW05S Lock washer, #10, SS LW10S Lock washer, 1/4, SS LW15S Lock washer, 5/16, SS LW20S Lock washer, 3/8 light, SS LW25S Lock washer, 3/8 heavy, SS RHS10S Round head screw, 10-32 x 3/4, SS RHS20S Round head screw, 10-32 x 1 1/4, SS RHS30S Round head screw, 1/4-20 x 7/8, SS SSS15 Set screw, 5/16-18 x 5/16 cup point SSS20 Set screw, 3/8-16 x 3/8 cup point S1007 Channel bracket, SS, #3850 on S11 Ratchet trigger, SS S1120 Order S1120EZ S1120EZ Channel, #3850 on, SS S155-11 Meat carriage stop thumb screw, SS S155B Meat carriage stop angle, welded S163F Platter spacer weld button, SS S18005 SS head, ORDER AS18005 S18006 SS head door, ORDER AS18006 S18007 Channel bracket, SS, to #3850 S18007AL Channel bracket filler plate, left, SS S18007AR Channel bracket filler plate, right, SS S18120 Channel, box type, SS, to #3850 S181155EZ Meat carriage top & angle, EZ flow S18189 Ratchet arm stud, SS S18217L Base door, left, SS, #2051 on S18217R Base door, right, SS, #2051 on S18239 Base, SS, NOT SOLD S18253 Upper wheel aligning screw, SS S200B1 Stop stud gde bar & crg. stop, SS S217C Base door hinge pin long, SS S217E Base door hinge pin short, SS S229 Wheel cleaner arm spring, SS S235 Taper pin, 4 x 3/4, SS S239-B30 Base foot, SS, welded S239-B41 Hex Leg 7/8-9x3 SS S/N 8125 ON S239-B42 Base Foot 2" DIA. S/N 8125 ON</p>	<p>S240 Ratchet trigger spring, SS S244 Wheel cleaner arm stud, SS S262 Meat gauge release handle, SS S265 Meat gauge release spring, SS S268 Stationary bar headless screw, SS S290 Cleaning unit stamping, SS S295 Wheel cleaner arm, SS S325 Wheel cleaner washer, SS S360CB-1 Carriage bolt, 3/8-16 x 1 1/4, SS S415D Stainless stationary bar S416 Platter locator weld pin, SS 10A Ratchet arm taper pin 11 Ratchet trigger, ORDER S11 112-212 Waved washer, 2 1/4 x 5/8 116-27 Saw guide bar, 27" 119A Saw guide in stationary bar 119FSC Saw guide in sta. bar, fish 120E Flat head screw, 5/16-18 x 2, SS 130 Saw cleaner bracket, rear 131 Saw cleaner, SS 14TH Head door hinge, welded 14TP Hinge pin, long, 1 1/2" 14TP-1 Hinge pin, short, 1 1/4" 16Z Lower guide bracket saw cleaner holder 16112 Head door latch 16132 Saw cleaner brkt. holder, rear 16155-13 Meat carriage stop angle 16155-2A Meat carriage guide, prior to EZ flow 16155-2B Carriage guide spacer, 1/4" 16115-2C Carriage guide spacer, 1/32" 16159 Meat carriage bearing, SS 16200 Carriage stop only, movable 16220-1 Carriage stop only, fixed 16296-2 Switch mtg. bracket, SS 163A Platter rod clip 17211-22 Finger lift shim, .022" 17211-35 Finger lift shim, .035" 175-1-S Thumb guard nut, SS 175-2-S Thumb screw, 1/4-20 x 1/2 175S Thumb guard, nylon 177 Sta. bar nylon filler 179 Wheel cleaner 18001 Upper bearing spacer, prior to snap ring spacers 18003 Lower wheel, 18" 18003U Upper wheel w/snap rings, 18" 18005 Head, aluminum, ORDER AS18005 18006 Head door, aluminum, ORDER A18006 18007 Channel bracket to #3849 18010 Ratchet arm 18019 Ratchet base 18111 Tension spring pin 181155 Meat carriage, #3850 to #7989 ORDER 181155EZ-RPL 18118 Tension spring plate 18120B1 Carriage guide bar, to #3849 18120B2 Carriage guide bar spacer, to #3849 18120EZ-B3 Guide bar, EZ flow, T-shaped, #7990 18154 Table extension 18155-OS Meat carriage top & angle, to #3849 18163B Platter neck guard 18163L Platter spacer channel strip, SS 18196 Saw tension spring 18197 Tension spring gauge 18198 Cap for tension pin 18212W Platter rod 18230DL Upper shaft seal, double lip 18231DL Lower shaft seal, double lip 18232 Scrap bucket 18247 Upper shaft</p>		

Item No.	Description	Item No.	Description
18248	Upper wheel hub cap	270	Meat gauge release pin
18251AL	Upper v-belt pulley, 12.8 × 1 $\frac{1}{8}$ "	271AL	Meat gauge worm gear
18252	Upper shaft lock nut	272-6-S	Meat gauge wing nut
18260	Slide gib, aluminum	272-7-1	Lock knob, $\frac{5}{16}$ -18, 3 point
18272	Meat gauge gear rack	272-8	Cap nut, $\frac{5}{16}$ -18, SS
18273	Meat gauge bracket, ORDER A18273	272-9	Hex head screw, $\frac{5}{16}$ -18 × 2, SS
18275	Meat gauge arm	272-12	Brass ball, $\frac{7}{32}$ dia.
18275-5	Meat gauge plate, SS	272-13	Hex head bolt, $\frac{5}{16}$ -18 × 1 $\frac{1}{4}$, SS
18280	Motor shaft key	272-14	Castle nut, $\frac{5}{16}$ -18, SS
18300	Lower shaft woodruff key	275THS	Truss head screw, $\frac{1}{4}$ -20 × $\frac{3}{8}$
18301	Model & S/N plate, S/N required	275THS-1	Truss head screw, $\frac{1}{4}$ -20 × 1
18302	Saw blade, 135", 420	277	Lower shaft key
18302HT	Saw blade, 135", 322 hard tooth	290-7	Cleaning unit locator
18305	Saw guide bar stop in head, to #4511	290-8	Cleaning unit locator washer
18308	Babbitt pocket shield, to #4511	290-8K	Cleaning unit locator kit
18311	Bumper for stops, to #3850	296-3	Switch bracket – external mount
18313-105	Operating and Parts Manual	299L	Saw guide bar stop, long, to #4510
18335X	Upper wheel hinge plate	310	Waved washer
18360	Lower bearing housing	311	Bumper for fixed carriage stop
18361	Lower shaft	311-1	Bumper for movable carriage stop
19CB	Ratchet base carriage bolt, $\frac{1}{4}$ -20 × $\frac{3}{4}$, SS	324A	Motor shim, $\frac{1}{8}$ "
193	Saw guide bar spring	340	Star external lock washer
211	Finger lift bracket	360A1	Grease fitting
211A-291Q	Finger lift fastener knob, 4 point, plastic	360B	Set screw, $\frac{3}{8}$ -16 × $\frac{1}{2}$, flat point
211D	Finger lift fastener stud, $\frac{3}{8}$ -16 × 1 $\frac{3}{4}$, SS	360B-1	Set screw, $\frac{1}{2}$ -13 × $\frac{1}{2}$, flat point
212CP	Platter rod cotter pin	362	Lower bearing housing adjusting cap
221-	V-belt *ADVISE SIZE*	375	Drive screw for name plate
228-2	Lower guide washer	376	Drive screw, 10 × $\frac{1}{2}$, SS
234	Grease fitting for upper wheel	4-40AL	Motor pulley, 5 × 1, 60 cycle
237	Upper shaft castellated lock nut	4-50AL	Motor pulley, 6 × 1, 50 cycle
238	Upper shaft castellated lock washer	415D	Stationary bar
239-B30-1	Base foot, carbon, ORDER AS239-B30-B	512	Upper wheel hub gasket
239-B31-2	Pipe leg, 6", aluminum	531	Upper wheel snap ring
239-B32-AR	Pipe leg cap	601	Upper saw guide bracket
240	Ratchet trigger spring, ORDER S240	602B	Upper saw guide
242R	Base door lock, right	602AFSC	Upper saw guide, narrow, fish
247A	Upper shaft washer	605	Lower blade back-up guide
249	Base door handle	661-1	Saw guard on head door, to #4510
252X	Shaft lock nut	662	Saw guard w/708 for Stainless head, SS
256P	Safety end cut pusher plate, composition	663	Saw guard w/708 for Aluminum head, SS
256PM	Safety end cut pusher plate, aluminum	671	Wall poster, "BANDSAW SAFETY GUIDELINES"
264-1	Meat gauge hand wheel	708	Decal "DANGER EXPOSED BLADE"
264G	Meat gauge hand wheel groove pin	71-2	Upper wheel hinge bracket
265	Meat gauge release spring, ORDER S265		
267	Meat gauge release cotter key		

COMPLETE ASSEMBLIES FOR MODEL 44

Item No.	Description	Item No.	Description
AS1120EZ	Channle assembly, EZ flow, SS	A16220-1	Carriage stop assembly, fixed
AS18005	Head & door assembly, SS	A16132	Saw cleaner assembly, rear
AS18006	Head door assembly, SS	A175S	Thumb guard assembly
AS290	Cleaning unit stamping assembly	A18003U	Upper wheel assembly w/o hinge plate
AS290-1	NOT SOLD AS ASSEMBLY	A18003U335	Upper wheel assembly w/hinge plate
AS415D	SS stationary bar assembly	A18006	Head door assembly, aluminum, to #4511
A112	Head door handle assembly, to #4511	A18019	Ratchet assembly
A116-27	Saw guide bar assembly, 27"	A181155	ORDER A18115EZ-RPL
A130	Saw cleaner assembly	A18115EZ	Meat carriage assembly, EZ flow, #7990 on
A16Z	Guide bracket saw cleaner assembly	A18115EZ-RPL	Meat carriage assembly, #3850 to #7989
A16112	Head door latch assembly, after #4511	A18155-OS	Meat carriage assembly, to #3850
A16200	Carriage stop assembly, movable	A18163	Stationary platter assembly

WARNING LABEL LOCATIONS ON MACHINE

ALWAYS
LOWER
GUARD
TO
HEIGHT
OF
PRODUCT



DANGER
EXPOSED
BLADE
↓

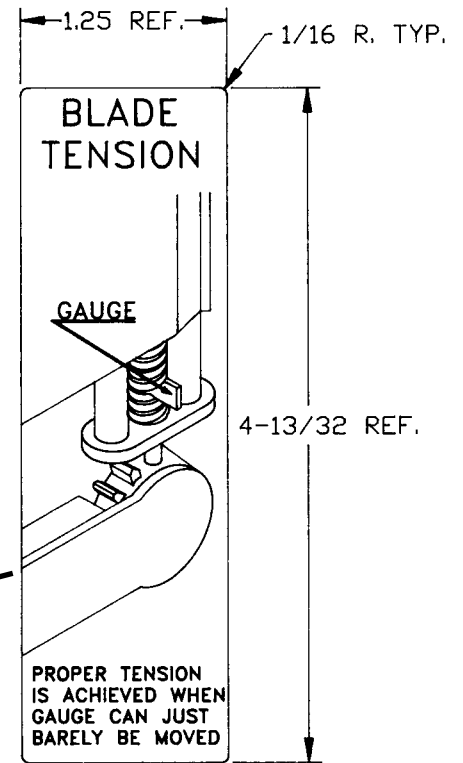

P/N 708 "DANGER EXPOSED
BLADE" DECAL

ATTACHED TO SAW GUARD
ON SAW GUIDE BAR

P/N 710 "BLADE
TENSION" DECAL

ATTACH TO HEAD
DOOR AS SHOWN

WARNING LABEL LOCATIONS ON MACHINE

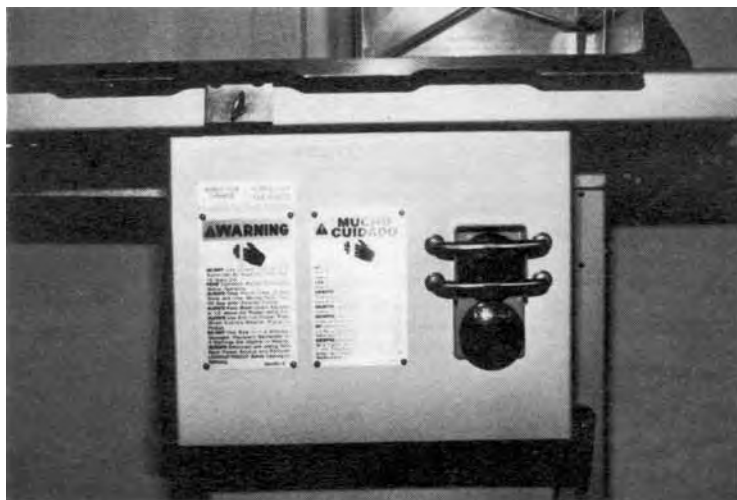

ATTACH TO CHANNEL BRACKET NEXT TO
SWITCH CONTROL BUTTONS

1 EA. 653PC-E
1EA. 653PC-SP

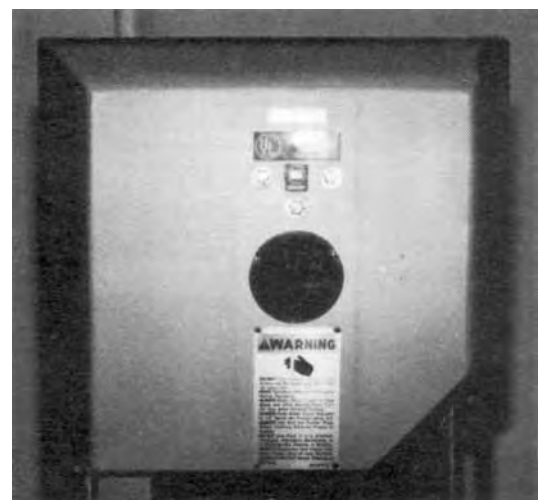

ATTACH ON HEAD STRUCTURE BELOW
MODEL/SERIAL NUMBER TAG

1 EA. 653PC-E

ITEM NUMBER 671

WALL CHART "BAND SAW SAFETY GUIDELINES"

ATTACH TO WALL IN VICINITY OF MACHINE IN EASY VIEW OF OPERATOR



WARNING

ONLY PROPERLY TRAINED PERSONNEL SHOULD USE THIS EQUIPMENT

**This Saw Contains A Sharp Blade.
To Reduce Risk of Injury:**

1. Before Using, Make Sure:

- Gauge Plate (A) And Other Components Are Secure.
- All Warning Labels And Guards Are In Place.
- The Guide Bar (B) Is Adjusted To $\frac{1}{2}$ Inch Above The Product To Be Cut

2. While Cutting:

- Keep Hands and Fingers Away From Blade.
- Keep Product Securely Against Gauge Plate.
- Use End Cut Pusher (C) When Making Final Cuts. Item No. 256P.

3. Before Cleaning:

- Turn Off Power and Unplug.
- Remove Saw Blade.
- Use Extra Care When Handling The Saw Blade.

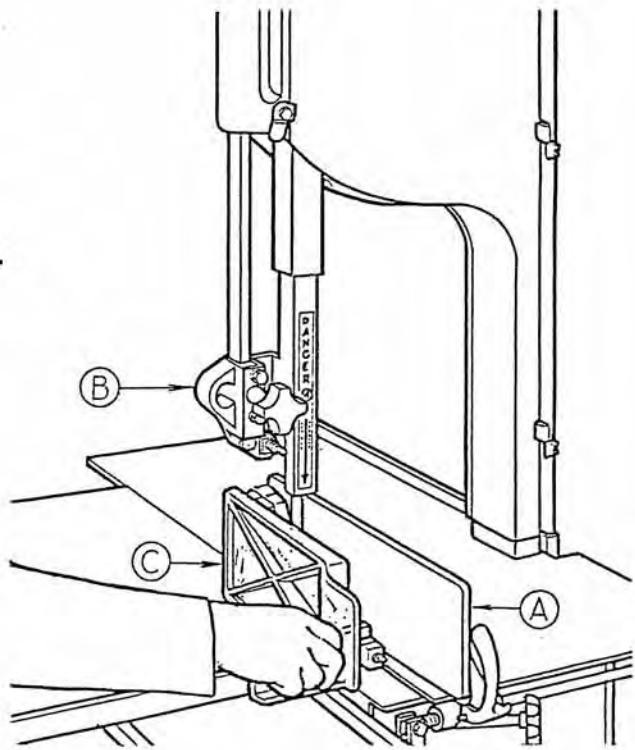

USE YOUR MEAT SAW SAFELY!

SEE PARTS AND SERVICE MANUAL SUPPLIED WITH MACHINE FOR ADDITIONAL SAFETY INFORMATION.

LIMITED WARRANTY:

WARRANTY: The BIRO Manufacturing Company warrants that Model 44 will be free from defects in material and workmanship under normal use and with recommended service. BIRO will replace defective parts, which are covered by this limited warranty, provided that the defective parts are authorized for return, shipping charges prepaid, to a designated factory for inspection and/or testing.

DURATION OF WARRANTY: The warranty period for all parts covered by this limited warranty is one (1) year from date of Inspection/Demonstration advised on the returned Warranty Registration card, or eighteen (18) months from original factory ship date, whichever occurs first, except as noted below.

PARTS NOT COVERED BY WARRANTY: The following are **not** covered by this limited warranty: wearable parts on the cleaning system such as wheel cleaners (Item No. 179), saw blade cleaners (Item No. 131), blade backup guides (Item No's. 602B, 605 and 119A), and the nylon filler (Item No. 177). This limited warranty does not apply to machines sold as used, rebuilt, modified, or altered from the original construction in which the machine was shipped from the factory. (WATER CONTAMINATED ELECTRICAL SYSTEMS ARE NOT COVERED UNDER THIS LIMITED WARRANTY.) BIRO is not responsible for electrical connection of equipment, adjustments to switch controls or any other electrical requirements, which must be performed only by a certified electrician. BIRO is not responsible for service charges or labor required to replace any part covered by this limited warranty or for any damages resulting from misuse, abuse, lack of proper or recommended service.

EXCLUSION OF WARRANTIES AND LIMITATION OF REMEDIES: BIRO gives no warranties other than those expressly stated in this limited warranty. THE IMPLIED WARRANTY OF MERCHANTABILITY, THE IMPLIED WARRANTY OF FITNESS FOR PROCESSING FOOD PRODUCTS, AND ALL OTHER IMPLIED WARRANTIES ARE SPECIFICALLY EXCLUDED. BIRO IS NOT LIABLE FOR CONSEQUENTIAL OR INCIDENTAL DAMAGES, EXPENSES, OR LOSSES. THE REMEDIES PROVIDED IN THIS BIRO LIMITED WARRANTY ARE PURCHASER'S SOLE AND EXCLUSIVE REMEDIES AGAINST BIRO.

REGISTRATION CARDS: You must sign, date and complete the warranty registration card supplied with each machine. The warranty card must be returned to The Biro Manufacturing Company for proper registration. If no warranty card is returned to BIRO, the warranty period will begin from the date the machine was originally shipped from the factory.

HOW TO GET SERVICE:

1. Contact the agency from whom you purchased the machine; or
2. Consult the yellow pages of the phone directory for the nearest authorized dealer; or
3. Contact Biro Mfg. Company for the nearest authorized service entity (250 plus worldwide) in your area.

THE BIRO MANUFACTURING COMPANY

1114 Main Street
Marblehead, Ohio 43440-2099
Ph. 419-798-4451
Fax 419-798-9106
E-mail: Service@biro.saw.com
Web: <http://www.birosaw.com>