



BIRO GRINDER PARTS LIST STAINLESS MODEL 6642

Starting with Serial No. 2321 (Screw Lock Bowl)

Starting with Serial No. 8151 (Removable Tray Assembly)

Starting with Serial No. 9340 (IDEC Pushbuttons, DIN Size Magnetic Starter)



☆ IMPORTANT SAFETY NOTICE ☆

This Manual contains important safety instructions which must be strictly followed when using this equipment.

TABLE OF CONTENTS

	Page
NOTICE TO OWNERS AND OPERATORS	1
SAFETY TIPS	2
INSTALLATION	3
UNCRATING AND SET UP	3
MOTOR WIRING AND ELECTRICAL REQUIREMENTS	4
MOTOR SPECIFICATIONS	5
WARNING LABELS AND LOCATIONS ON GRINDER	5
PARTS DIAGRAMS, PARTS ORDERING BASIC MACHINE	6
INSTRUCTIONS: REMOVING TRAY ASSEMBLY	7
INSTRUCTIONS: ASSEMBLING GRINDING BOWL	7
INSTRUCTIONS: REMOVING GRINDING BOWL	7
OPERATION	8
TO PROCESS PRODUCT	8
CLEANING	9
MAINTENANCE	10
GRINDING BOWL INSTALLATION	10
GEAR BOX LUBRICATION	10
GEAR BOX ASSEMBLY PARTS DIAGRAMS AND PARTS ORDERING	11
MAGNETIC SWITCH SYSTEMS PARTS DIAGRAMS AND PARTS ORDERING	12
WIRING DIAGRAMS	13
PARTS LISTS/ORDERING FOR GRINDERS PRIOR TO SERIAL NO. 9340	14
OPERATOR'S SIGNATURE PAGE	15
LIMITED WARRANTY	16

NOTICE TO OWNERS AND OPERATORS

BIRO's products are designed to process food products safely and efficiently. Unless the operator is properly trained and supervised, however, there is the possibility of a serious injury. It is the responsibility of the owner to assure that this machine is used properly and safely, strictly following the instructions contained in this Manual and any requirements of local law.

No one should use or service this machine without proper training and supervision. All operators should be thoroughly familiar with the procedures contained in this Manual. Even so BIRO cannot anticipate every circumstance or environment in which its products will be used. You, the owner and operator, must remain alert to the hazards posed by the function of this equipment particularly the ROTATING GRINDING WORM, which can severely injure an inattentive operator amputating fingers and limbs. No one under eighteen (18) years of age should operate this equipment. If you are uncertain about a particular task, ask your supervisor.

This Manual contains a number of safe practices in the SAFETY TIP section. Additional warnings are placed throughout the Manual. Warnings related to your personal safety are indicated by:



OR



Warnings related to possible damage to the equipment are indicated by:



BIRO also has provided warning labels on the equipment. If any warning label or Manual becomes misplaced, damaged, or illegible, please contact your nearest Distributor or BIRO directly for a replacement.

Remember, however, this Manual or the warning labels do not replace the need to be alert and to use your common sense when using this equipment.

This Manual applies to machines with Serial Number 2321 and higher.

- NOTE -

“A copy of this manual is included with each Model 6642 Grinder.”

“The descriptions and illustrations contained in this manual are not binding. The manufacturer reserves the right to introduce any modification without updating the manual .”

SAFETY TIPS



ROTATING GRINDING WORM TO AVOID SERIOUS PERSONAL INJURY

***NEVER** Touch This Machine Without Training and Authorization By Your Supervisor.*

***NEVER** Place Hands Into Machine Input or Output Openings.*

***NEVER** Open Machine During Operation*

***ONLY** Use a Qualified Electrician to Install According to Local Building Codes: Machine **MUST** Be Properly Grounded.*

***ALWAYS** Connect to **Proper** Voltage & Phase.*

***ONLY** Install on Level, Non-Skid Surface in a Clean, Well-Lighted Work Area Away From Children and Visitors.*

***NEVER** Use This Machine For Non-food Products.*

***NEVER** Operate Machine With Tray And/Or Tray Guard Removed or Magnetic Safety Switch By-Passed.*

***ALWAYS** Turn Off, Unplug From Power Source and Perform Lockout/Tagout Procedure to This Machine **BEFORE** Attempting to Unjam or unclog, Cleaning or Servicing.*

***NEVER** Leave Machine Unattended While Operating.*

***NEVER** Alter This Machine From its Original Form as Shipped From Factory. **DO NOT** Operate Machine With Parts Missing.*

***PROMPTLY REPLACE** Any Worn or Illegible Warning Labels.*

***ALWAYS** Read Operation and Service Manual **BEFORE** Operating, Cleaning or Servicing.*

***USE ONLY BIRO** Parts and Accessories Properly Installed.*

INSTALLATION



TO AVOID SERIOUS PERSONAL INJURY PROPERLY INSTALL EQUIPMENT IN ADEQUATE WORK AREA

ALWAYS Use Qualified Technician and Electrician for Installation.

*ALWAYS Connect to **Proper** Voltage & Phase.*

ALWAYS Install Equipment in Work Area with Adequate Light and Space Away From Children and Visitors.

ONLY Operate on a Solid, Level, Non-Skid Surface.

NEVER Bypass, Alter, or Modify This Equipment in Any Way From Its Original Condition.

NEVER Operate With Tray And /Or Tray Guard Removed or Magnetic Safety Switch By-Passed.

NEVER Operate Without all Warning Labels Attached and Owner/Operator Manual Available to the Operator.

UNCRATING AND SET UP

1. Read this Manual thoroughly before installation and operation. **Do not** proceed with installation and operation if you have any questions or do not understand anything in this Manual. Contact your local Distributor, or BIRO **first**.
2. Install machine on a level, solid, non-skid surface in a well-lighted work area away from children and visitors.



ALWAYS LEVEL MACHINE BEFORE USING

3. After installing machine in operational area, it is imperative that the four adjusting legs be adjusted to level the machine and also eliminate rocking.
4. This machine is complete **except** for a knife and plate. There is a bowl shipping plug (stamped steel) placed in the output end of the grinding bowl to retain the grinding worm during shipment. **REMOVE THE BOWL SHIPPING PLUG AND THE GRINDING WORM.**



5. After checking and making sure the power supply is correct, plug in your machine. **NEVER OPERATE MACHINE WITHOUT TRAY AND GUARD INSTALLED.** (Machine will not run with tray removed.)

6. Machine must be properly grounded. Use qualified electrician to install according to building codes.

MOTOR WIRING AND ELECTRICAL REQUIREMENTS

- (A) Interchange of current is made in motor outlet box. Leads are properly marked. Changing instructions are on the motor plate or motor outlet box.
- (B) All grinders are wired 220 volts unless otherwise specified. Be sure motor specifications (voltage, cycle, phase) match power supply line. Be sure line voltage is up to specification.
- (C) Electrical connections to be in accordance with safety codes and National Electrical Code.
- (D) Rated voltage of the unit shall be identical with full supply voltage.
- (E) Voltage drop on the supply line shall not exceed 10% of full supply voltage.
- (F) The feederline conductor size in the raceway from the branch circuit to the unit must be correct to assure adequate voltage under heavy starting and short overload conditions.
- (G) The feederline conductor shall only be used for the supply of one unit of the relevant horsepower. For connections of more than one unit on the same feederline, a local electrician will have to be consulted to determine the proper conductor size.
- (H) The size of the electrical wiring required from the power source to the grinder for 208/220/230/440/550 Volts is a MINIMUM of No. 12 AWG. For 110/115 Volts is a MINIMUM of No. 10 AWG.
- (I) The BIRO Manufacturing Company is not responsible for permanent wiring, connection or installation.

NOTE TO OWNER AND ELECTRICIAN: IF THIS MACHINE IS NOT CORD AND PLUG CONNECTED TO THE ELECTRICAL SUPPLY SOURCE, THEN IT SHOULD BE EQUIPPED WITH, OR CONNECTED TO, A LOCKABLE, MANUALLY-OPERATED DISCONNECT SWITCH (1010.147 OSHA).



HP	VOLTS	MOTOR		
		HZ	PH	AMPS
2	104	60	1	31
2	115	60	1	28
2	208	60	1	15.5
2	230	60	1	14
2	208 dedicated	60	3	5.0
2	208/220	50/60	3	6.2/6.0
2	440	50/60	3	3.0
2	550	60	3	2.24

7. Pushbuttons that activate the internal on/off switch are located on the side of the machine. The interlock safety switch is mounted inside the machine case toward the front and will break contact with the magnetic starter should the tray be removed.



8. Push the green “ON” button. **CHECK THE ROTATION OF THE WORM DRIVE SHAFT. ROTATION MUST BE COUNTER-CLOCKWISE** as indicated by the rotation decal affixed to the grinding bowl. **ROTATION MUST ONLY BE CHECKED WITH THE GRINDING WORM REMOVED**, otherwise serious irreparable damage may occur to grinding components. Push red “STOP” button.
9. If machine runs clockwise (backwards), it must be rewired to correct rotation, otherwise serious irreparable damage may occur to grinding components.
10. Insert worm assembly into grinding bowl, place knife (sharp edges out) onto the square end of the worm assembly. The breaker plate slides over the worm knife drive pin, and is held from rotating by pins in the grinding bowl. Install on the retaining ring.



ONLY HAND TIGHTEN RETAINING RING

For best results, use knife and plate as a set. **Do not operate machine for any period of time** without product in the grinding bowl. This will cause heating and dulling of the knife and plate.

11. Check placement of all warning labels and Manual. Machine is now ready for trained operators to process product.
12. Use meat deflector attached to tray to eliminate meat splatter.
13. Contact your local Distributor or BIRO directly if you have any questions or problems with the installation or operation of this machine.

WARNING LABELS & LOCATIONS ON GRINDER

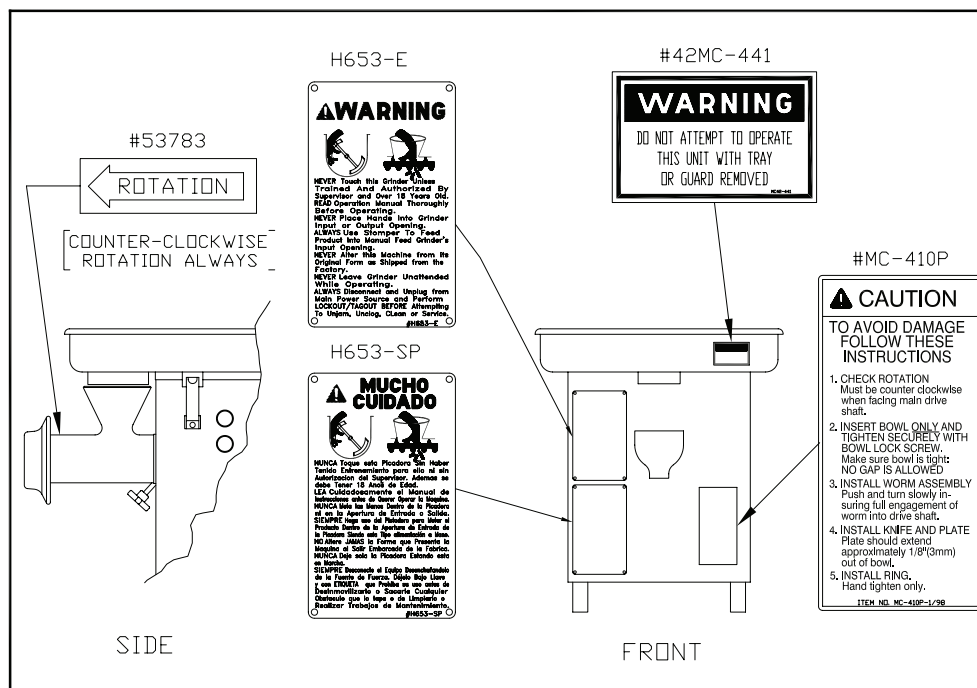

**IMPORTANT:
PLEASE SPECIFY SERIAL NUMBER WHEN
ORDERING REPLACEMENT PARTS**

**MODEL 6642 GRINDER PARTS LISTS
STARTING WITH SERIAL NO. 9340**

Item No.	Description
FW10S	Flat washer, 5/16, SS
HHS025S	Hex head screw, 1/4 - 20 x 1/2, SS
HN15S	Hex nut, 1/4 - 20, SS
HN20S	Hex nut, 5/16-18, SS
HP48	Bowl plate locator pin, 7/32 x 1/8
LW10S	Lock washer, 1/4, SS
MC-2BL	Bowl locator pin, dowel
16163A	Hold down clip
42MC-Y20-2	Meat deflector angle bracket
42MC-Y20-8	Magnet, with hole
42MC-Y20-8A	Magnet, #1851 on
42MC-Y24X1	Motor base plate
42MC-Y24-2	Case to mtr. base plate, truss hd. screw
42MC-Y25-CB	Carriage bolt, 1/4 - 20 x 1/2, SS
42MC-Y25D	Case, SS, #9340 on (for IDEC pb.)
42MC-Y25-5	Case cover plate, #8181 on, SS
42MC-Y37P-N	Legs, 1 1/2 x 22 inch, (optional)
42MC-Y37P4-N	Legs, 1 1/2 x 4 inch aluminium (std.)
42MC-Y71	Hold down latch, #8151 on
42MC-Y72	Self retaining "U" nut, 1/4 - 20
42MC-Y73	Green "START" button, IDEC
42MC-Y74	Red "STOP" button, IDEC
42MC-Y75	"START" legend plate
42MC-Y76	"STOP" legend plate
42MC-124-N	Steel coupling
42MC-125	Rubber foot plug (optional)
42MC-15C	Open bowl
42MC-16AZ	Worm drive shaft
42MC-16CZ	Knife drive pin
42MC-19	Bowl end ring
42MC-329A	Pipe leg cap - nylon
42MC-47SFT	Stomper
42MC-47SFT-SLD	Stomper, solid
42MC-49-2	Standoff for SS tray guard
42MC-49SS	Tray guard, ORDER AS ASSEMBLY

NOT SHOWN	
42MC-Y25BR1	Model & S/N plate, (S/N required)
42MC-Y53-047	Operating and Service Manual
42MC-655	Poster, Cutting Tips/Grinder

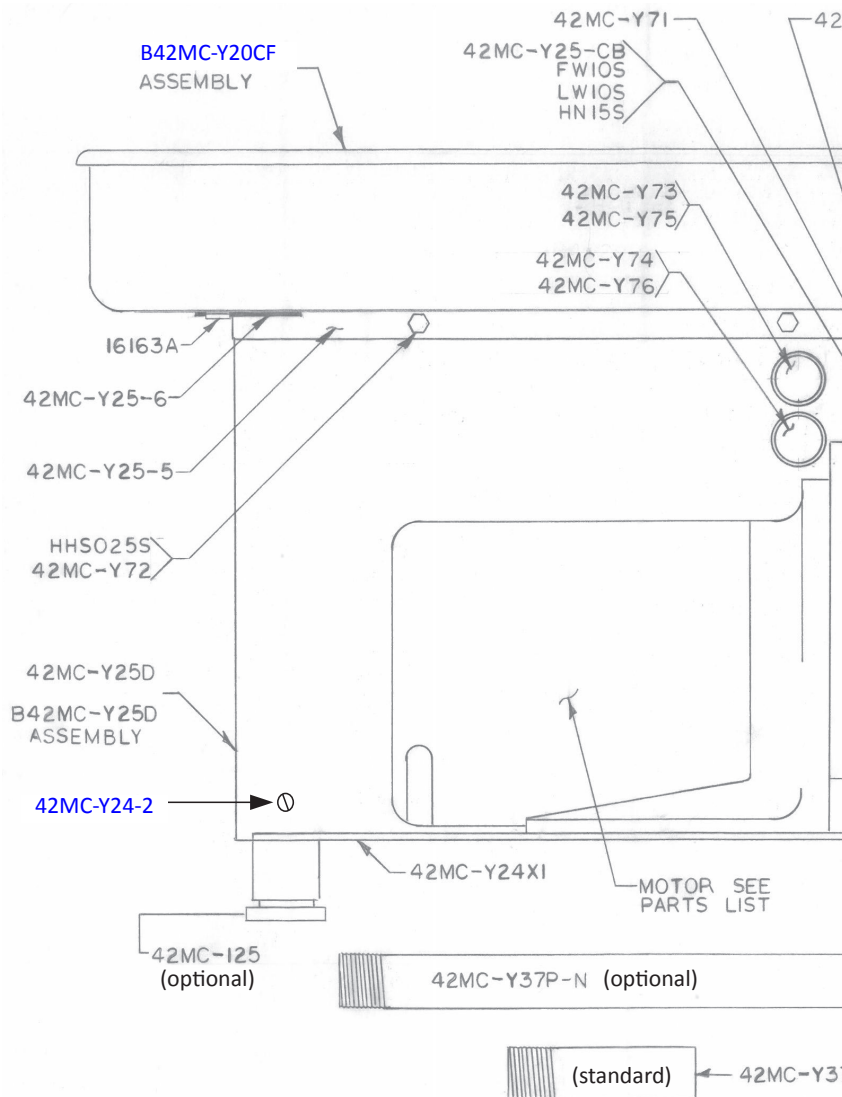

ASSEMBLIES FOR MODEL 6642 GRINDER

Item No.	Description
BMC-1Z-1	Gear box assembly
BMC-Y21R-3	Bowl lock assembly, 9/16, #3663 on
B42MC-15C	Open bowl assembly, screw lock #2321 on
B42MC-Y20CF	Removable tray assembly, #8151 on
B42MC-Y25D	Case assembly, w/ model plate and labels, # 9340 on, (for IDEC pushbuttons)
B42MC-Y71	Removable tray latch assembly #8151 on
B42MC-Y90A	Meat deflector arm assembly
B42MC-16BY	Worm assembly

TO REMOVE TRAY ASSEMBLY

1. Unplug grinder from power source, perform lockout/tagout procedures.
2. Unlock Tray Hold Down Latches
3. Lift front tray enough for magnet to clear the case top, slide Tray Assembly toward back of grinder and lift off.

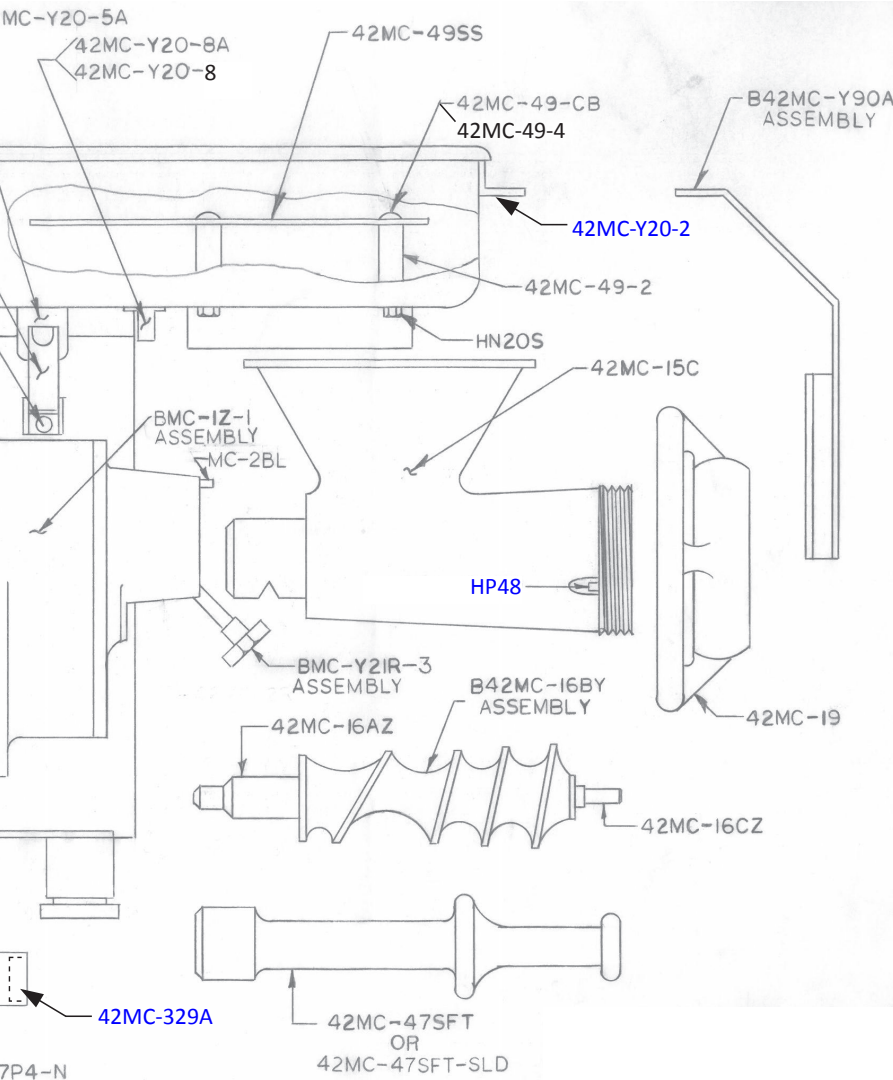

TO ASSEMBLE BOWL

1. Make certain the Bowl Lock Screw is unscrewed sufficiently to allow free entry of Grinding Bowl.
2. With End Retaining Ring, Knife, Breaker Plate and Grinding Worm removed, insert the Grinding Bowl fully into the gear box housing, making sure that the rear end of the Grinding Bowl is flush with the gear box housing .
3. Tighten the Bowl Lock Screw.
4. Insert the Grinding Worm and fully seat square drive.
5. Install the Knife (sharp side out) and Breaker Plate.
6. Install End Retaining Ring.
HAND TIGHTEN ONLY.

MOTORS FOR MODEL 6642 GRINDER

Item No.	Description
42MC-10-4U	Motor, 2HP, 550-60-3, U.S. G57892
42MC-10-5U	Motor, 2HP, 104/208-60-1, U.S. G57328
42MC-10-6U	Motor, 2HP, 115/230-60-1, U.S. G54314
42MC-10-7U	Motor, 2HP, 208/230/460-50/60-3, U.S. 57893
42MC-10-8U	Motor, 2HP, 115/230-50-1, U.S. G57901
42MC-10-9U	Motor, 2HP, 208-60-3, U.S. G57890

TO REMOVE GRINDING BOWL

1. Unplug grinder from power source, perform lockout/tagout procedures.
2. Remove End Retaining Ring, Knife, Breaker Plate, and Grinding Worm.
3. Loosen Bowl Lock Screw (counter-clockwise).
4. Remove Grinding Bowl.

OPERATION



ROTATING GRINDING WORM TO AVOID SERIOUS PERSONAL INJURY

***ONLY** Properly Trained Personnel Should Use This Equipment.*

***NEVER** Place Hands Into Machine Input or Output Openings.*

***NEVER** Open Machine During Operation.*

***DO NOT** Wear Gloves While Operating.*

***DO NOT** Tamper With, Bypass, Alter, or Modify This Equipment in Any Way From Its Original Condition.*

***NEVER** Operate Machine With Tray And/Or Tray Guard Removed or Magnetic Safety Switch By-Passed.*

***ALWAYS** Turn Off, Unplug From Power Source and Perform Lockout/Tagout Procedure to This Machine **BEFORE** Unjamming, Unclogging, Cleaning or Servicing.*

***NEVER** Leave Unattended While Operating.*

***NEVER** Operate Without all Warning Labels Attached and Owner/Operator Manual Available to the Operator.*

A. TO PROCESS PRODUCT

1. Before starting grinder, have meat stomper within easy reach and a container for receiving ground product at the output end of grinding bowl.
2. Push the green “ON” button. Look down grinder bowl and make certain grinding worm is turning in the proper direction (counter-clockwise).
3. Carefully push unground product to top opening of grinding bowl and let drop onto the grinding worm. Product will then be ground out.



DO NOT REACH DOWN BOWL OPENING

4. Use meat stomper to assist any product that should “bridge up” in grinding bowl opening.
5. When finished grinding, push the red “OFF” button and unplug grinder from power source and perform lockout/tagout procedures.

DO's

- Always keep knife & plate as matched set.
- Always keep knife & plate sharp.
- Always check for levelness by laying the knife on the plate before inserting in machine.
- Always install the knife & plate in correct sequence, knife 1st, then plate.
- Always keep knives & plates lubricated in storage and when starting up machine.
- Always use coolant when sharpening plates
- Always inspect the plates making sure all holes are clear- that there are no cracks.

DON'Ts

- Never, never mix different knives to different plates.
- Never, never overtighten the bowl retaining ring on the machine.
- Never, never run the grinder/mincer without product. Product is a natural lubricant. Heat can build up so fast that cold product could crack the plate.
- Never, never hit the plate against anything to clean the holes.
- Never, never throw the knives & plates.

CLEANING



ROTATING GRINDING WORM TO AVOID PERSONAL INJURY

ALWAYS Turn Off, Unplug From Power Source and Perform Lockout/Tagout Procedure to This Machine **BEFORE** Unjamming, Unclogging, Cleaning or Servicing.

ONLY Use Recommended Cleaning Equipment, Materials and Procedures.

NEVER Spray Water or Other Liquid Substances Directly at Motor, Power Switch or any Other Electrical Components.

ALWAYS Thoroughly Clean Equipment at Least Daily.

CLEANING THE BIRO MODEL 6642 GRINDER

1. Disconnect grinder from power source and perform lockout/tagout procedures.
2. Remove the feed tray.
3. Remove grinding bowl end ring, breaker plate, knife, grinding worm and the grinding bowl.



DO NOT SPRAY DIRECTLY AT ELECTRICAL COMPONENTS

4. Machine is now ready to be cleaned using warm soapy water and rinsed with clean water. Machine may be cleaned by power spray washing, taking care to not spray directly at any electrical controls.
5. After machine has been cleaned and allowed to dry, all exposed metal surfaces should be coated with a good food grade light oil or grease.

CLEANING THE BOWL- RING AND WORM
CARE OF TIN COATED PRODUCTS
(DO'S AND DON'TS)

1. Do not use abrasive cleaning materials, such as brillo pads or metal scrapers. Tin is a soft metal and should be cleaned with a soft cloth and dried.
2. Do not use a cleaning agent containing a high percentage of free alkali or acid.
3. Do not use a detergent containing a high percentage of tri-sodium phosphate or meta-silicate. Tin is reactive to both.
4. Rinse well and dry thoroughly after washing to remove agents that may be reactive to tin.
5. If sterilizing agent containing chlorine is used, the tinned surface must be thoroughly rinsed. Chlorine is corrosive to tin.
6. Dry thoroughly after rinsing and store in a dry environment.
7. If water is exceptionally hard, drying will be necessary to prevent spotting.

MAINTENANCE



**ROTATING GRINDING WORM
TO AVOID SERIOUS PERSONAL INJURY**

***ALWAYS** Turn Off, Unplug From Power Source and Perform Lockout/Tagout Procedure to This Machine **BEFORE** Unjamming, Unclogging, Cleaning or Servicing.*

***NEVER** Touch This Machine Without Training and Authorization By Your Supervisor.*

***NEVER** Place Hands Into Machine Input or Output Openings.*

***NEVER** Bypass, Alter, or Modify This Equipment in Any Way From Its Original Condition.*

***PROMPTLY REPLACE** Any Worn or Illegible Labels.*

***USE ONLY GENUINE BIRO** Parts and Accessories Properly Installed.*

A. GRINDING BOWL INSTALLATION

1. Mount the grinding bowl in the gear box opening. Insert screw lock under the grinding bowl and hand tighten fully seating the bowl.
2. Place the grinding worm in the grinding bowl and fully seat rear drive tang into worm drive shaft.
3. Install knife, breaker plate and end retaining ring.



ONLY HAND TIGHTEN RETAINING RING

4. When the bowl assembly is mounted and tight, there should be approximately 1/8" gap between the back inside wall of the bowl and the back of the worm. The bowl wrench which is provided with each grinder is used only for **REMOVAL** of the end retaining ring for cleaning purposes or for changing knife and breaker plate.

B. GEAR BOX LUBRICATION

1. The gear box lubricant should be changed after the first four (4) weeks of operation to remove any metal particles that may be generated during the initial mating of the gears.
2. Thereafter at one (1) year intervals.
3. There is a drain plug on the underside of the gear box.
4. Refill with a measured one (1) pint of LUBRIPLATE #APG-140 gear oil or equivalent.

MODEL 6642 GEAR BOX ASSEMBLY PARTS LIST

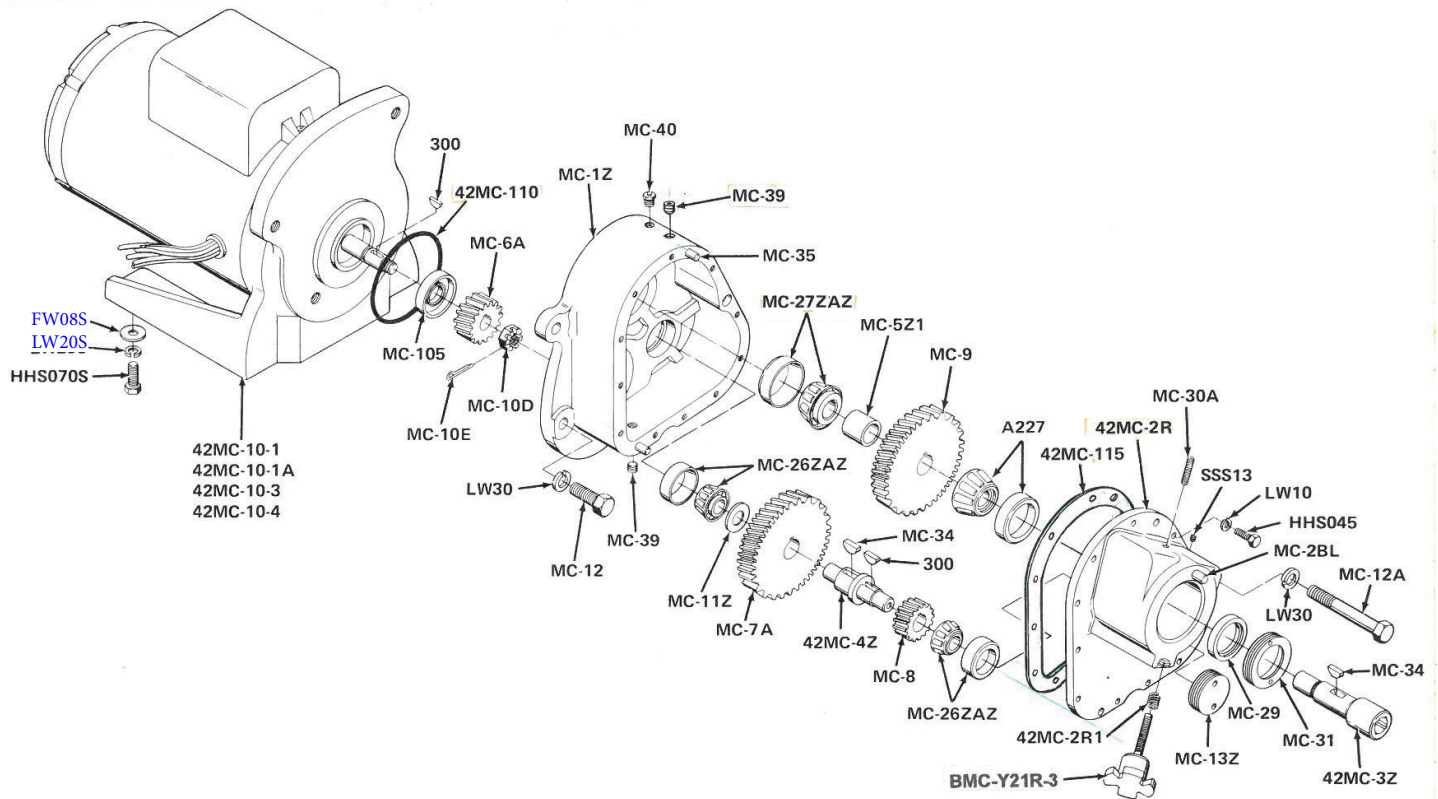

Item No.	Description
FW08S	Flat washer, 3/8, SS
HHS045	Hex head screw, 1/4 - 20 x 7/8
HHS070S	Hex head screw, 3/8-16 x 1, SS
LW10	Lock washer, 1/4
LW20S	Lock washer, 3/8, SS
LW30	Lock washer, 1/2"
MC-1Z	Gear box only
MC-10D	Motor shaft slotted nut
MC-10E	Cotter key, 1/8 x 1
MC-105	Motor seal, lip type
MC-11Z	Lower shaft washer
MC-12	Gear box motor bolt, short
MC-12A	Gear box motor bolt, long
MC-13Z	Lower shaft bearing adj. cap
MC-2BL	Bowl locator pin, dowel
MC-29	Upper shaft oil seal
MC-30A	Upper bearing cap set screw, long
MC-31	Adjusting cup & seal housing
MC-34	Woodruff gear key, #91
MC-35	Gear box cover locator pin
MC-39	Oil plug, 1/8 x 3/8
MC-40	NPT vented plug, 1/8

Item No.	Description
MC-5Z1	Upper shaft spacer
MC-51L	Gear box lubricant, 1 pint
MC-6A	Motor pinion gear
MC-7A	Idler gear
MC-8	Idler pinion gear
MC-9	Drive gear
SSS13	Set screw, 1/4 - 20 x 3/8
300	Lower shaft woodruff key
42MC-110	Gear box O-ring seal, #8493 on
42MC-115	Gear box cover gasket
42MC-2R	Gear box cover only, #2321 on
42MC-2R1	Heli-coil insert, SS #3663 on
42MC-3Z	Upper shaft hollow square end, #2321 on
42MC-4Z	Lower shaft

ASSEMBLIES FOR GEAR BOX

Item No.	Description
A227	Upper bearing cup/cone assembly
B42MC-2R	Gear box cover assembly, #2321 on
B42MC-3Z	Upper shaft hollow square end assembly
B42MC-4Z	Lower shaft assembly
BMC-1Z-1	Gear box assembly, #2321 on with motor seal
BMC-Y21R-3	Bowl lock assembly, #2321 on
MC-26ZAZ	Idler bearing cup/cone
MC-27ZAZ	Rear thrust bearing cup/cone

**MODEL 6642 MAGNETIC SWITCH SYSTEM
WITH INTERLOCK SWITCH STARTING WITH SERIAL NO. 9340
CONTACTOR COIL VOLTAGE MUST BE SAME AS POWER SUPPLY VOLTAGE**

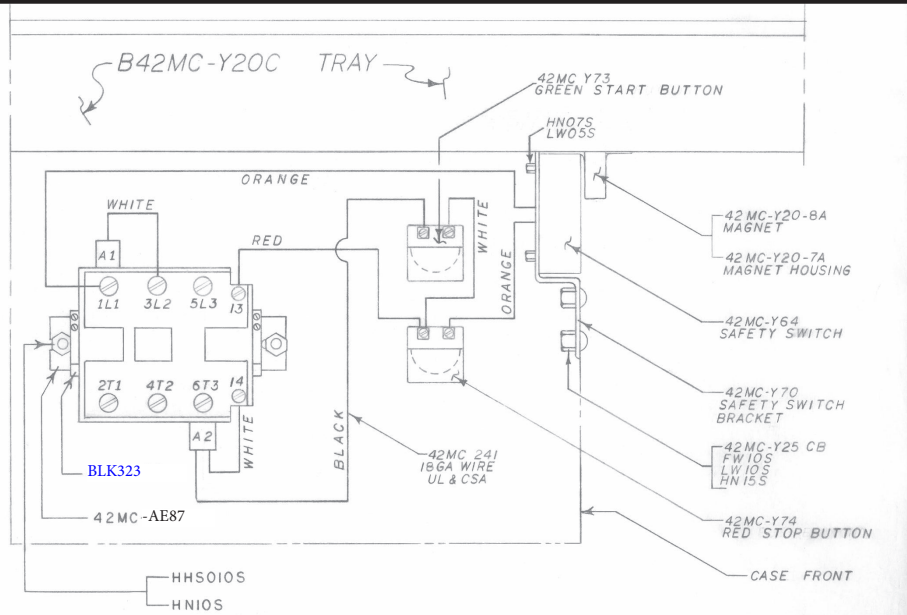

**PARTS LIST FOR AEG CONTACTORS STARTING WITH SERIAL NO. 9340
NOTE: SEE CONTACTOR KIT NUMBERS BELOW FOR
SWITCHES USED BEFORE S/N 9340**

Item No.	Description	Item No.	Description
42MC-Y20-8A	Magnet S/N 8151 on	42MC-AE79-CL	Coil, 220V
42MC-Y64	Magnet safety interlock switch, S/N 5796 on (up to 250V)	226EE-OL08.5L	AEG overload 2HP, 1 & 3PH (208/230V) 5.5-8.5 amp
H442-1	Magnet safety interlock switch, (250V and up)	226EE-EO11K	AEG contactor, 2HP, 3 PH (440V), 60Hz
42MC-Y67	Flange spade crimp-on connector	226EE-EO11K	AEG contactor, 2HP, 3 PH same/coil rated 400V (380/415V) 50Hz
42MC-Y70	Safety switch bracket	226EE-FO11K	AEG contactor, 2HP, 3 PH (550V) 60Hz
42MC-Y73	Green "START" button, IDEC	226EE-GO11K	AEG contactor, 2HP, 3 PH (24V) 50/60Hz
42MC-Y74	Red "STOP" button, IDEC	226EE-AO15K	AEG contactor, 2HP, 1 PH (110/120V) 60Hz
42MC-Y75	"Start" legend plate	42MC-AE87	3.5" long din rail
42MC-Y76	"Stop" legend plate	BLK323	End barrier
42MC-Y77	Switch hole cap plug	HHS010S	Hex head screw, 10-32 x 3/8, SS
226EE-CO11K	AEG contactor, 2HP, 1 & 3 PH, (208/220/230V), 50/60 Hz.	HN10S	Hex nut, 10-32, SS
42MC-EE79A	AEG contactor & overload 2HP, 1 & 3 PH (208/230V), 50/60 Hz.		

CONTACTOR KIT NUMBERS FOR SWITCHES USED BEFORE S/N 9340

Item No.	Description	Item No.	Description
42MC-Y20-8	Magnet S/N 5796 to 8150	42MC-EE82K	AEG overload 2HP, 3PH (440V) 60Hz w/ din rail, fasteners and clips
42MC-Y60	Magnet safety interlock switch bracket S/N 5796 to 8151	42MC-EE84K	AEG overload 2HP, 1PH (110/120V) 60Hz w/ din rail, fasteners and clips
42MC-EE79K	AEG overload 2HP, 1 & 3PH (208/220/230V) 50-60Hz w/ din rail fasteners and clips	6808-G	Toggle switch (1PH) to S/N 5796
42MC-EE80K	AEG overload 2HP, 3PH (440V) 60Hz w/ din rail, fasteners and clips	7810-G	Toggle switch (3PH) to S/N 5796
42MC-EE81K	AEG overload 2HP, 3PH (380-415V) 50Hz w/ din rail, fasteners and clips	800S-2ASQ	GP Push button station - flush mount S/N 5796-9339

SCHEMATIC-1

**MODEL 6642 - SINGLE PHASE
WIRING DIAGRAM USING AEG CONTACTOR
FOR 1-PH (115-208-220-230V) 50-60Hz**

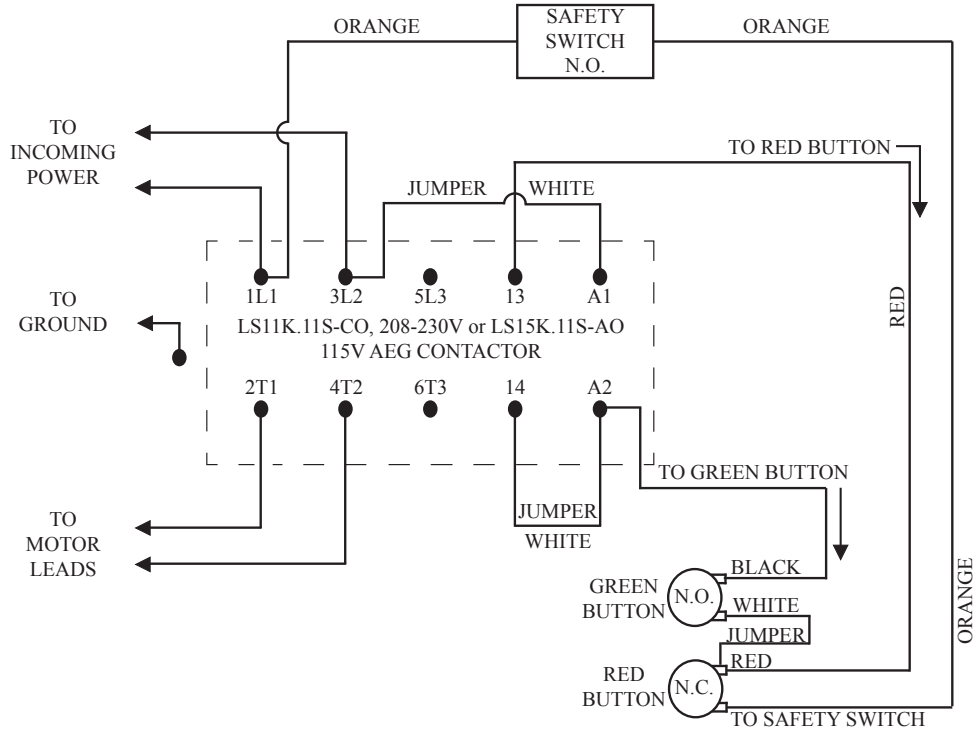

SCHEMATIC-2

**MODEL 6642 - THREE PHASE
WIRING DIAGRAM USING AEG CONTACTOR
FOR 3-PH (208-220-230-380-460-550V) 50-60Hz**

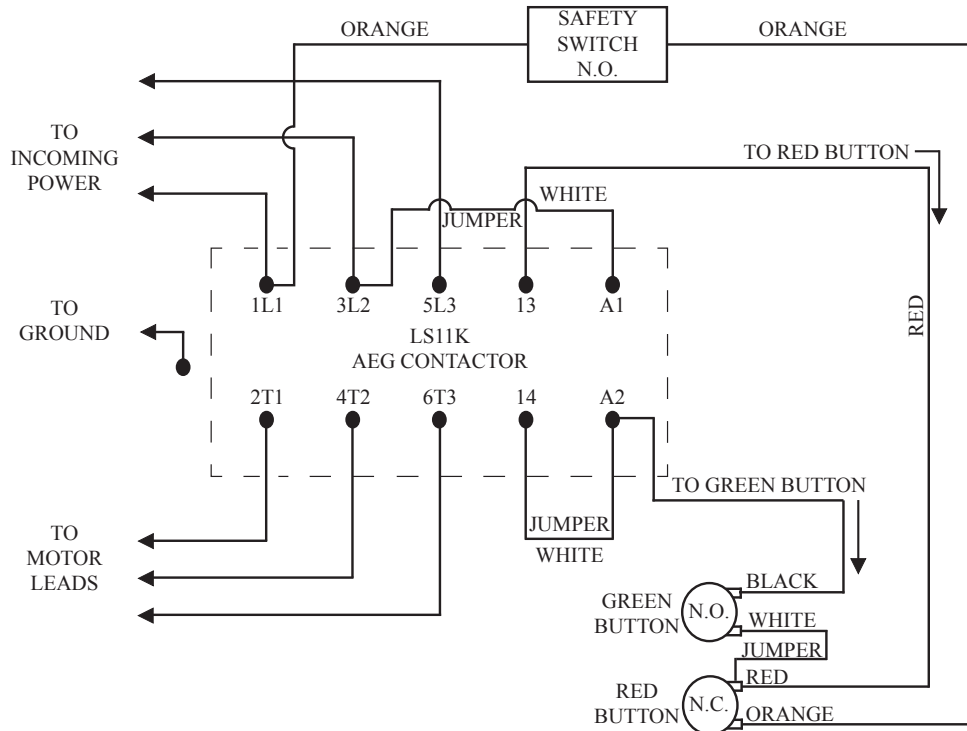

**IMPORTANT:
PLEASE SPECIFY SERIAL NUMBER WHEN
ORDERING REPLACEMENT PARTS.**

PARTS LIST SPECIFIC TO MACHINES PRIOR TO SERIAL NO. 9340

Item No.	Description
M99-2-17	Station switch, 2HP, 50Hz, Baldor motor
M99-2-17A	Rotary switch, 2HP, 50/60Hz, Baldor motor
MC-100	Motor seal, ORDER MC-105
MC-25B	Model plate switch slot
MC-25B1	Name plate self-tap screw
MC-25C	Model plate case screw
MC-25D	Switch to model plate screw 6-32 x $\frac{3}{8}$
42MC-Y25B	Case, SS, 18 inch, #5796 to 8150
42MC-Y25B5	Adapter plate, switch to new case
42MC-Y49-1	Drive screw for aluminum guard, #14 x $\frac{5}{8}$
42MC-49SFT	Tray guard, aluminum, #4800 to 8272

ASSEMBLIES PRIOR TO SERIAL NO. 9340

Item No.	Description
BMC-Y21R-1	Bowl lock assembly, $\frac{1}{2}$ ", to #3663
B42MC-L20	Large tray with guard safety kit, to #2000
B42MC-Y20A-OS	Tray with guard & safety kit, #2000 to 4799
B42MC-Y20A1	Tray assembly with guard & magnet, #5796 to 8151
B42MC-Y25C	SS case assembly with model plate & decals #8151 to 9339
B42MC-Y25E	SS case assembly, 18", #4800 to 5795
B42MC-Y25F	SS case assembly, 18", #2000 to 4800

LIMITED WARRANTY

WARRANTY: The BIRO Manufacturing Company warrants that the BIRO Model 6642 Grinder will be free from defects in material and workmanship under normal use and with recommended service. BIRO will replace defective parts, which are covered by this limited warranty, provided that the defective parts are authorized for return, shipping charges prepaid, to a designated factory for inspection and/or testing.

DURATION OF WARRANTY: The warranty period for all parts covered by this limited warranty is one (1) year from date of inspection/demonstration as advised on the returned Warranty registration card, or eighteen (18) months from original factory shipping date, whichever date occurs first, except as noted below.

PARTS NOT COVERED BY WARRANTY: The following are **not** covered by this limited warranty: wearable parts in the grinding system such as the bowl, worm drive shaft, ring, worm, and knife drive pin. This limited warranty does not apply to machines sold as used, rebuilt, modified, or altered from the original construction in which the machine was shipped from the factory. Water contaminated electrical systems are not covered under this limited warranty. BIRO is not responsible for electrical connection of equipment, adjustments to switch components or any other electrical requirements, which must be performed only by a certified electrician. BIRO is not responsible for service charges or labor required to replace any part covered by this limited warranty or for any damages resulting from misuse, abuse, lack of proper or recommended service.

EXCLUSION OF WARRANTIES AND LIMITATION OF REMEDIES: BIRO gives no warranties other than those expressly stated in this limited warranty. THE IMPLIED WARRANTY OF MERCHANTABILITY, THE IMPLIED WARRANTY OF FITNESS FOR PROCESSING OF FOOD PRODUCTS, AND ALL OTHER IMPLIED WARRANTIES ARE SPECIFICALLY EXCLUDED. BIRO IS NOT LIABLE FOR CONSEQUENTIAL OR INCIDENTAL DAMAGES, EXPENSES OR LOSSES. THE REMEDIES PROVIDED IN THIS BIRO LIMITED WARRANTY ARE PURCHASER'S SOLE AND EXCLUSIVE REMEDIES AGAINST BIRO.

REGISTRATION CARDS: You must sign, date and complete the warranty registration card supplied with each machine. The warranty card must be returned to The Biro Manufacturing Company for proper registration. If no warranty card is returned to BIRO, the warranty period will begin from the date the machine was originally shipped from the factory.

HOW TO GET SERVICE:

1. Contact the agency from whom you purchased the machine; or
2. Consult the yellow pages of the phone directory for the nearest authorized dealer; or
3. Contact Biro Mfg. Company for the nearest authorized service entity in your area.

BIRO MANUFACTURING COMPANY

1114 Main St.

Marblehead, OH 43440 U.S.A.

Telephone: 419-798-4451 Fax: 419-798-9106

E-mail: service@birosaw.com; <http://www.birosaw.com>