



MODELS 8-12 AND 8-22
OPERATION AND SERVICE MANUAL
GRINDER PARTS LIST
GENERAL INSTRUCTIONS

Starting with Serial No. 5200, No. C84001 with Chain Drive
and No. C84859 with HTD Drive Belt

Note: This Catalog does not pertain to 8-12/8-22 with Plastic Gears



BIRO Designed

BIRO Built

☆ **IMPORTANT SAFETY NOTICE** ☆

This Manual contains important
safety instructions which must
be strictly followed when using
this equipment.

PTCT
8-12/8-22
No. C657-111

TABLE OF CONTENTS

	Page
NOTICE TO OWNERS AND OPERATORS	1
SAFETY TIPS	2
INSTALLATION	3
UNCRATING AND SET UP	3-4
MOTOR WIRING AND ELECTRICAL REQUIREMENTS	4
ELECTRICAL CONTACTORS	4
OPERATION	5
TO PROCESS PRODUCT	5
CLEANING	6
MAINTENANCE	7
HIGH TORQUE DRIVE SYSTEM	7
BEARINGS	7
TRAY AND CASE PARTS DIAGRAM	8
TRAY AND CASE PARTS LIST AND PARTS ORDERING	9
BOWL, FRAME AND MOTOR PARTS DIAGRAM	10
BOWL, FRAME AND MOTOR PARTS LIST AND ORDERING	11
WIRING DIAGRAMS	12-13
OPERATOR'S NOTES	14
OPERATOR'S SIGNATURE PAGE	15
LIMITED WARRANTY	16

NOTICE TO OWNERS AND OPERATORS

BIRO's products are designed to process food products safely and efficiently. Unless the operator is properly trained and supervised, however, there is the possibility of a serious injury. It is the responsibility of the owner to assure that this machine is used properly and safely, strictly following the instructions contained in this Manual and any requirements of local law.

No one should use or service this machine without proper training and supervision. All operators should be thoroughly familiar with the procedures contained in this Manual. Even so BIRO cannot anticipate every circumstance or environment in which its products will be used. You, the owner and operator, must remain alert to the hazards posed by the function of this equipment particularly the ROTATING GRINDING WORM, which can severely injure an inattentive operator amputating fingers and limbs. No one under eighteen (18) years of age should operate this equipment. If you are uncertain about a particular task, ask your supervisor.

This Manual contains a number of safe practices in the SAFETY TIP section. Additional warnings are placed throughout the Manual. Warnings related to your personal safety are indicated by:



OR



Warnings related to possible damage to the equipment are indicated by:



BIRO also has provided warning labels on the equipment. If any warning label or Manual becomes misplaced, damaged, or illegible, please contact your nearest Distributor or BIRO directly for a replacement.

Remember, however, this Manual or the warning labels do not replace the need to be alert and to use your common sense when using this equipment.

This Manual applies to machines with Serial Number 5200 AND C84001 and higher with chain drive and serial number C84859 and higher with HTD drive belt..

- NOTE -

“A copy of this manual is included with each Model 8-12/8-22 Grinder.”

“The descriptions and illustrations contained in this manual are not binding. The manufacturer reserves the right to introduce any modification without updating the manual .”

SAFETY TIPS



ROTATING GRINDING WORM TO AVOID SERIOUS PERSONAL INJURY

***NEVER** Touch This Machine Without Training and Authorization By Your Supervisor.*

***NEVER** Place Hands Into Machine Input or Output Openings.*

***NEVER** Open Machine During Operation*

***ONLY** Use a Qualified Electrician to Install Electrical Connections According to Local Building Codes:
Machine **MUST** Be Properly Grounded.*

***ALWAYS** Connect to **Proper** Voltage & Phase.*

***ONLY** Install on Level, Non-Skid Surface in a Clean, Well-Lighted Work Area Away From Children
and Visitors.*

***NEVER** Use This Machine For Non-food Products.*

***NEVER** Operate Machine With Tray Removed.*

***ALWAYS** Turn Off, Unplug From Power Source and Perform Lockout/Tagout Procedure to This
Machine **BEFORE** Attempting to Unjam or Unclog, Cleaning or Servicing.*

***NEVER** Leave Machine Unattended While Grinder is Running.*

***NEVER** Alter This Machine From its Original Form as Shipped From Factory. **DO NOT** Operate
Machine With Parts Missing.*

***PROMPTLY REPLACE** Any Worn or Illegible Warning Labels.*

***ALWAYS** Read Operation and Service Manual **BEFORE** Operating, Cleaning or Servicing.*

***USE ONLY BIRO** Parts and Accessories Properly Installed.*

INSTALLATION



TO AVOID SERIOUS PERSONAL INJURY PROPERLY INSTALL EQUIPMENT IN ADEQUATE WORK AREA

ALWAYS Use Qualified Technician and Electrician for Installation.

*ALWAYS Connect to **Proper** Voltage & Phase.*

ALWAYS Install Equipment in Work Area with Adequate Light and Space Away From Children and Visitors.

ONLY Operate on a Solid, Level, Non-Skid Surface.

NEVER Bypass, Alter, or Modify This Equipment in Any Way From Its Original Condition.

NEVER Operate With Tray Removed.

NEVER Operate Without all Warning Labels Attached and Owner/Operator Manual Available to the Operator.

UNCRATING AND SET UP

1. Read this Manual thoroughly before installation and operation. **Do not** proceed with installation and operation if you have any questions or do not understand anything in this Manual. Contact your local Distributor, or BIRO **first**.
2. Install machine on a level, solid, non-skid surface in a well-lighted work area away from children and visitors.
3. This machine is complete **except** for a knife and plate. The grinding bowl assembly is packed separately in the crate. Remove the grinding bowl assembly from the carton. Disassemble the grinding bowl assembly. Assemble the grinding bowl only, onto the front of the grinder. Install the bowl lock handle assembly into the frame under the grinding bowl. Securing the bowl. The back flange of the grinding bowl should be tight against the front of the machine. Do not install grinding worm at this time.



4. Install the feed tray to the top of the grinder. After checking and making sure the power supply is correct, plug in your machine. **NEVER OPERATE MACHINE WITHOUT TRAY INSTALLED.**
5. Machine must be properly grounded. Use qualified electrician to install according to building codes.
6. A toggle switch is located on the front of the machine.



7. Push the toggle switch to “ON” position. **CHECK THE ROTATION OF THE WORM DRIVE SHAFT ROTATION MUST BE COUNTER-CLOCKWISE** as indicated by the rotation decal affixed to the grinding bowl. **ROTATION MUST ONLY BE CHECKED WITH THE GRINDING WORM REMOVED**, otherwise serious irreparable damage may occur to grinding components. Push toggle switch to “OFF” position.

UNCRATING AND SET UP - CONTINUED

8. If machine runs clockwise (backwards), it must be rewired to correct rotation, otherwise serious irreparable damage may occur to grinding components.
9. Check that the grinding bowl is properly seated and that the bowl lock assembly is tight. Insert worm assembly into grinding bowl, place knife (sharp edges out) onto the square end of the knife drive pin. The breaker plate slides over the worm knife drive pin, and is held from rotating by a pin in the grinding bowl. Put on the retaining ring.



ONLY HAND TIGHTEN RETAINING RING

For best results, use knife and plate as a set. **Do not operate machine for any period of time** without product in the grinding bowl. This will cause heating and dulling of the knife and plate.

10. Check placement of all warning labels and Manual. Machine is now ready for trained operators to process product.
11. Contact your local Distributor or BIRO directly if you have any questions or problems with the installation or operation of this machine.

MOTOR WIRING AND ELECTRICAL REQUIREMENTS

- (1) Interchange of current is made in motor outlet box. Leads are properly marked. Changing instructions are on the motor plate or motor outlet box. Electrical contactor mounted on machine frame must also be changed to match motor voltage.
- (2) All grinders are wired for the voltage as ordered. Be sure motor specifications (voltage, cycle, phase) match power supply line. Be sure line voltage is up to specification.
- (3) Electrical connections to be in accordance with safety codes and National Electrical Code.
- (4) Rated voltage of the unit shall be identical with full supply voltage.
- (5) Voltage drop on the supply line shall not exceed 10% of full supply voltage.
- (6) The feederline conductor size in the raceway from the branch circuit to the unit must be correct to assure adequate voltage under heavy starting and short overload conditions.
- (7) The BIRO Manufacturing Company is not responsible for permanent wiring, connection or installation.



NOTE TO OWNER AND ELECTRICIAN: IF THIS MACHINE IS NOT CORD AND PLUG CONNECTED TO THE ELECTRICAL SUPPLY SOURCE, THEN IT SHOULD BE EQUIPPED WITH, OR CONNECTED TO, A LOCKABLE, MANUALLY-OPERATED DISCONNECT SWITCH (OSHA 1010.147).

ELECTRICAL CONTACTORS

- (1) Most 1 HP motors are dual voltage and can be changed according to wiring diagram on motor nameplate.
- (2) Be sure contactor voltage matches voltage of motor.
 - A. Item No. C903 Contactor LS07-110V
 - 1 HP, 104-60-1
 - 1 HP, 115-60-1
 - 1 HP, 380/415/440-50/60-3 w/ **56110** transformer
 - B. Item No. **C903-1** Contactor LS07-220V
 - 1 HP, 220-50/60-3
 - 1 HP, 208/230-60-1
 - 1 HP, 240-50-
- (3) Failure to use proper contactor for motor voltage will cause irreparable damage to contactor.
- (4) Install proper plug on power cord for voltage used.

OPERATION



ROTATING GRINDING WORM TO AVOID SERIOUS PERSONAL INJURY

***ONLY** Properly Trained Personnel Should Use This Equipment.*

***NEVER** Place Hands Into Machine Input or Output Openings.*

***NEVER** Open Machine During Operation.*

***DO NOT** Wear Gloves While Operating.*

***DO NOT** Tamper With, Bypass, Alter, or Modify This Equipment in Any Way From Its Original Condition.*

***NEVER** Operate Machine With Tray Removed.*

***ALWAYS** Turn Off, Unplug From Power Source and Perform Lockout/Tagout Procedure to This Machine **BEFORE** Unjamming, Unclogging, Cleaning or Servicing.*

***NEVER** Leave Machine Unattended While Grinder is Running.*

***NEVER** Operate Without all Warning Labels Attached and Owner/Operator Manual Available to the Operator.*

A. TO PROCESS PRODUCT

1. Before starting grinder, have meat stomper within easy reach and a container for receiving ground product at the output end of grinding bowl.
2. Turn the toggle to “ON” position. Look down grinder bowl and make certain grinding worm is turning in the proper direction (counter-clockwise).
3. Carefully push unground product to top opening of grinding bowl and let drop onto the grinding worm. Product will then be ground out.



DO NOT REACH DOWN BOWL OPENING

4. Use meat stomper to assist any product that should “bridge up” in grinding bowl opening.
5. When finished grinding, turn the toggle to “OFF” position and unplug grinder from power source and perform lockout/tagout procedures.

CLEANING



ROTATING GRINDING WORM TO AVOID PERSONAL INJURY

ALWAYS Turn Off, Unplug From Power Source and Perform Lockout/Tagout Procedure to This Machine **BEFORE** Cleaning or Servicing.

ONLY Use Recommended Cleaning Equipment, Materials and Procedures.

NEVER Spray Water or Other Liquid Substances Directly at Motor, Power Switch or any Other Electrical Components.

ALWAYS Thoroughly Clean Equipment at Least Daily.

CLEANING THE BIRO MODEL 8-12/8-22 GRINDER

1. Disconnect grinder from power source and perform lockout/tagout procedures.
2. Remove the feed tray.
3. Remove grinding bowl end ring, breaker plate, knife, grinding worm and the grinding bowl.



DO NOT SPRAY DIRECTLY AT ELECTRICAL COMPONENTS

4. Machine is now ready to be cleaned using warm soapy water and rinsed with clean water. Machine may be cleaned by power spray washing, taking care to not spray directly at any electrical controls.
5. After machine has been cleaned and allowed to dry, all exposed metal surfaces should be coated with a good food grade light oil or grease.

CLEANING THE BOWL- RING AND WORM CARE OF TIN COATED PRODUCTS (DO'S AND DON'TS)

1. Do not use abrasive cleaning materials, such as brillo pads or metal scrapers. Tin is a soft metal and should be cleaned with a soft cloth and dried.
2. Do not use a cleaning agent containing a high percentage of free alkali or acid.
3. Do not use a detergent containing a high percentage of tri-sodium phosphate or meta-silicate. Tin is reactive to both.
4. Rinse well and dry thoroughly after washing to remove agents that may be reactive to tin.
5. If sterilizing agent containing chlorine is used, the tinned surface must be thoroughly rinsed. Chlorine is corrosive to tin.
6. Dry thoroughly after rinsing and store in a dry environment.
7. If water is exceptionally hard, drying will be necessary to prevent spotting.

MAINTENANCE



ROTATING GRINDING WORM TO AVOID SERIOUS PERSONAL INJURY

ALWAYS Turn Off, Unplug From Power Source and Perform Lockout/Tagout Procedure to This Machine **BEFORE** Servicing.

NEVER Touch This Machine Without Training and Authorization By Your Supervisor.

NEVER Place Hands Into Machine Input or Output Openings.

NEVER Bypass, Alter, or Modify This Equipment in Any Way From Its Original Condition.

PROMPTLY REPLACE Any Worn or Illegible Labels.

USE ONLY GENUINE BIRO Parts and Accessories Properly Installed.

A. HIGH TORQUE DRIVE SYSTEM

The Model 8-12/8-22 is driven by a High Torque Drive system for power transmissions.

“No Lubrication” is required (in fact) be sure no lubricant comes in contact with the sprockets or belt.

To insure a long life to the drive components:

1. Be sure the motor shaft and main drive shaft are parallel.
2. Be sure sprockets are in alignment.
3. Proper HTD belt tension is $\frac{3}{32}$ “ on one side.
Tension should be checked every six (6) months.

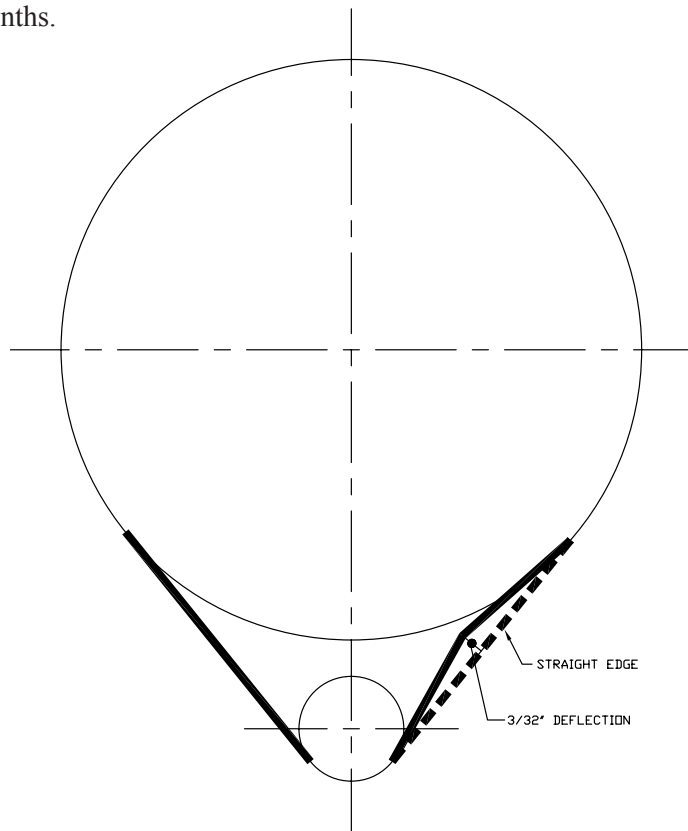

B. BEARINGS

1. The main drive shaft bearings are sealed for life. No need to lubricate.
2. The motor bearings are sealed for life.

TRAY AND CASE PARTS

H653-SP

MUCHO CUIDADO



NEVER Touch this Grinder Unless Trained and Authorized By Supervisor and Over 18 Years Old. **READ** Operation Manual Thoroughly Before Operating. **NEVER** Place Hands Into Grinder Input or Output Opening. **ALWAYS** Use Shorper To Feed Product Into Manual Feed Grinder's Input Opening. **NEVER** Alter this Machine from its Original Form as Shipped from the Factory. **NEVER** Leave Grinder Unattended While Operating. **ALWAYS** Disconnect and Unplug from Main Power Source and Perform LOCKOUT/TAGOUT BEFORE Attempting To Unjam, Unload, Clean or Service.

NEUNCA Toque esta Plandera Sin Haber Tenido Entrenamiento para ello ni sin Autorización del Supervisor, Además se debe Tener 18 Años de Edad. **LEA** Cuidadosamente el Manual de Instrucciones antes de Querer Usar la Máquina. **NEUNCA** Meta las Manos Dentro de la Plandera ni en la Apertura de Entrada o Salida. **SIEMPRE** Usa con del Shorper para Meter el Producto Dentro de la Apertura de Entrada de la Plandera Nunca Meta los dedos o Manos. **NO** Altere **JAMÁS** la Forma que Presenta la Máquina al Ser Embastado de la Fábrica. **NEUNCA** Deje esta Plandera Estando Solo en Marcha. **SIEMPRE** Desconecte el Equipo Desconectando de la Fuente de Fuerza. **Siempre** Quite Bajo Llave y con ENERGÍA que Previene en sus cables de Desconectarlo a Seguros Cualquiera Oportunidad que le Llega a de Limpiarlo o Realizar Trabajos de Mantenimiento.

H653-E

WARNING



NEVER Touch this Grinder Unless Trained and Authorized By Supervisor and Over 18 Years Old. **READ** Operation Manual Thoroughly Before Operating. **NEVER** Place Hands Into Grinder Input or Output Opening. **ALWAYS** Use Shorper To Feed Product Into Manual Feed Grinder's Input Opening. **NEVER** Alter this Machine from its Original Form as Shipped from the Factory. **NEVER** Leave Grinder Unattended While Operating. **ALWAYS** Disconnect and Unplug from Main Power Source and Perform LOCKOUT/TAGOUT BEFORE Attempting To Unjam, Unload, Clean or Service.

MC-410P

WARNING

AVOID PERSONAL INJURY OR DAMAGE FOLLOW THESE INSTRUCTIONS

1. INSERT BOWL ONLY AND TIGHTEN SECURELY WITH BOWL LOCK SCREW. Make sure bowl is tight NO GAP.
2. INSTALL WORM ASSEMBLY. Push and turn slowly insuring full engagement of worm into drive shaft.
3. INSTALL KNIFE AND PLATE. Plate should extend approximately 1/8"(3MM) out of bowl.
4. INSTALL RING. Hand tighten only.

ITEM NO. MC-410P-4/89

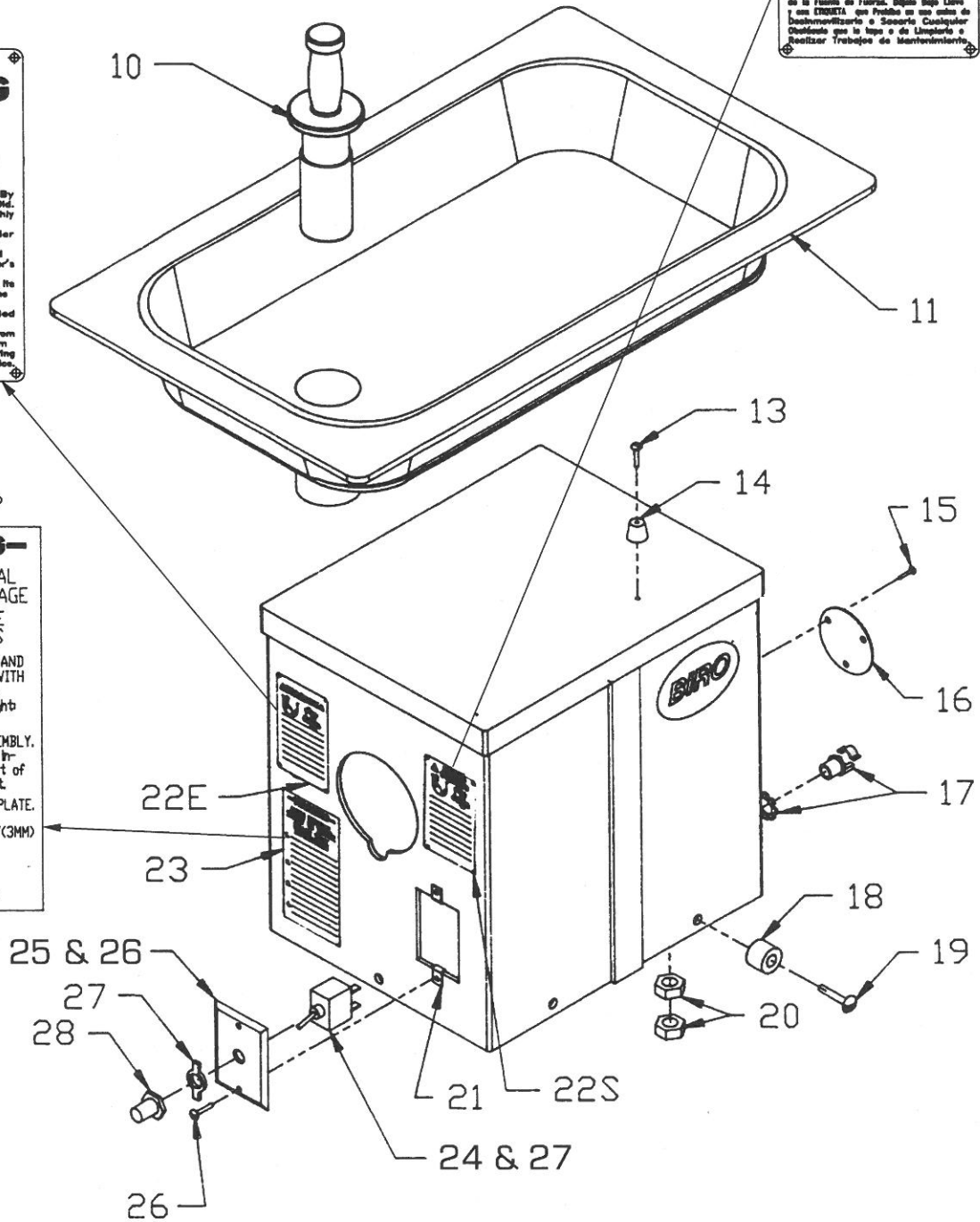

TRAY AND CASE PARTS LIST

Starting with Serial No.5200, No. C84001 and No. C84859 with HTD Drive Belt.
(This Catalog does not pertain to 8-12/8-22 with Plastic Gears)

NOTE: SPECIFY MODEL & SERIAL NUMBER WHEN ORDERING PARTS

MODEL 8-12 PARTS LIST (Tray and Case)			MODEL 8-22 PARTS LIST (Tray and Case)		
Fig.	Item No.	Description	Fig.	Item No.	Description
10	C606-1	Stomper, 2" (#10222 on)	10	C606-1	Stomper, 2" (#10377 on)
	C606-1-SLD	Stomper, Solid		C606-1-SLD	Stomper, Solid
11	C612-1	Tray SS 2 1/8" neck dia. (#10222 on)	11	C612-1	Tray SS 2 1/8" neck dia. (#10377 on)
12	C681A	Case Assembly, SS, C#-84859 on replaces C616, C616-1 & C680A	12	C681A	Case Assembly, SS, C#-84859 on replaces C616, C616-1 & C680A
	C680A	Case Assembly, (Use C681A)		C680A	Case Assembly, (Use C681A)
	C616	Case, Blue poly, (Use C681A)		C616	Case, Blue poly, (Use C681A)
	C616-1	Case Assembly, SS, (Use C681A)		C616-1	Case Assembly, SS, (Use C681A)
13	C643	10-24 x 1/2 round head screw	13	C643	10-24 x 1/2 round head screw
14	C613	Tray bumper (2 required)	14	C613	Tray bumper (2 required)
15	H374-1	Model & Serial plate pop rivet, 1/8"	15	H374-1	Model & Serial plate pop rivet, 1/8"
16	H333	Model & Serial plate (serial no. required upon order)	16	H333	Model & Serial plate (serial no. required upon order)
17	PC161	Strain relief fitting	17	PC161	Strain relief fitting
	241-LN	Locknut, metal type Used with PC161		241-LN	Locknut, metal type Used with PC161
18	C611-1	Rubber grommet for SS case	18	C611-1	Rubber grommet for SS case
	C611	Rubber grommet for poly case (#5200 to C#-84001)		C611	Rubber grommet for poly case (#5200 to C#-84001)
19	C649	5/16-18 x 3/4 round head screw	19	C649	5/16-18 x 3/4 round head screw
20	HN07S	10-24 hex nut	20	HN07S	10-24 hex nut
21	C682	6-32 "U" type retaining nut	21	C682	6-32 "U" type retaining nut
22E	H653-E	Warning label, English	22E	H653-E	Warning label, English
22S	H653-SP	Warning label, Spanish	22S	H653-SP	Warning label, Spanish
23	MC-410P	Bowl installation label, English	23	MC-410P	Bowl installation label, English
	MC-410SP	Bowl installation label, Spanish Not Shown		MC-410SP	Bowl installation label, Spanish Not Shown
24	C603M	Toggle switch w/ on-off plate, 1&3 (C#-84859 on) (McGill#3190-0003)	24	C603M	Toggle switch w/ on-off plate, 1&3 (C#-84859 on) (McGill#3190-0003)
	C603	Toggle switch, 1ph (Before C#-84859) (Use C603M)		C603	Toggle switch, 1ph (Before C#-84859) (Use C603M)
	C603-1	Toggle switch, 1ph (Before C#-84859) (Use C603M)		C603-1	Toggle switch, 1ph (Before C#-84859) (Use C603M)
25	C604-2	SS. Switch plate w/ mounting screws, (C#-84859 on)(P&S,S-11)	25	C604-2	SS. Switch plate w/ mounting screws, (C#-84859 on)(P&S,S-11)
	C604	Switch plate, 1ph, SS Use C604-2		C604	Switch plate, 1ph, SS Use C604-2
	C604-1	Switch plate, 3ph, SS (Before C#-84859)		C604-1	Switch plate, 3ph, SS (Before C#-84859)
26	FHS04S	6-32 x 1/2" flat hd screw	26	FHS04S	6-32 x 1/2" flat hd screw
27	N/A	On-Off plate, Use C603M	27	N/A	On-Off plate, Use C603M
28	C665	Rubber half boot for toggle	28	C665	Rubber half boot for toggle

BOWL, FRAME & MOTOR PARTS

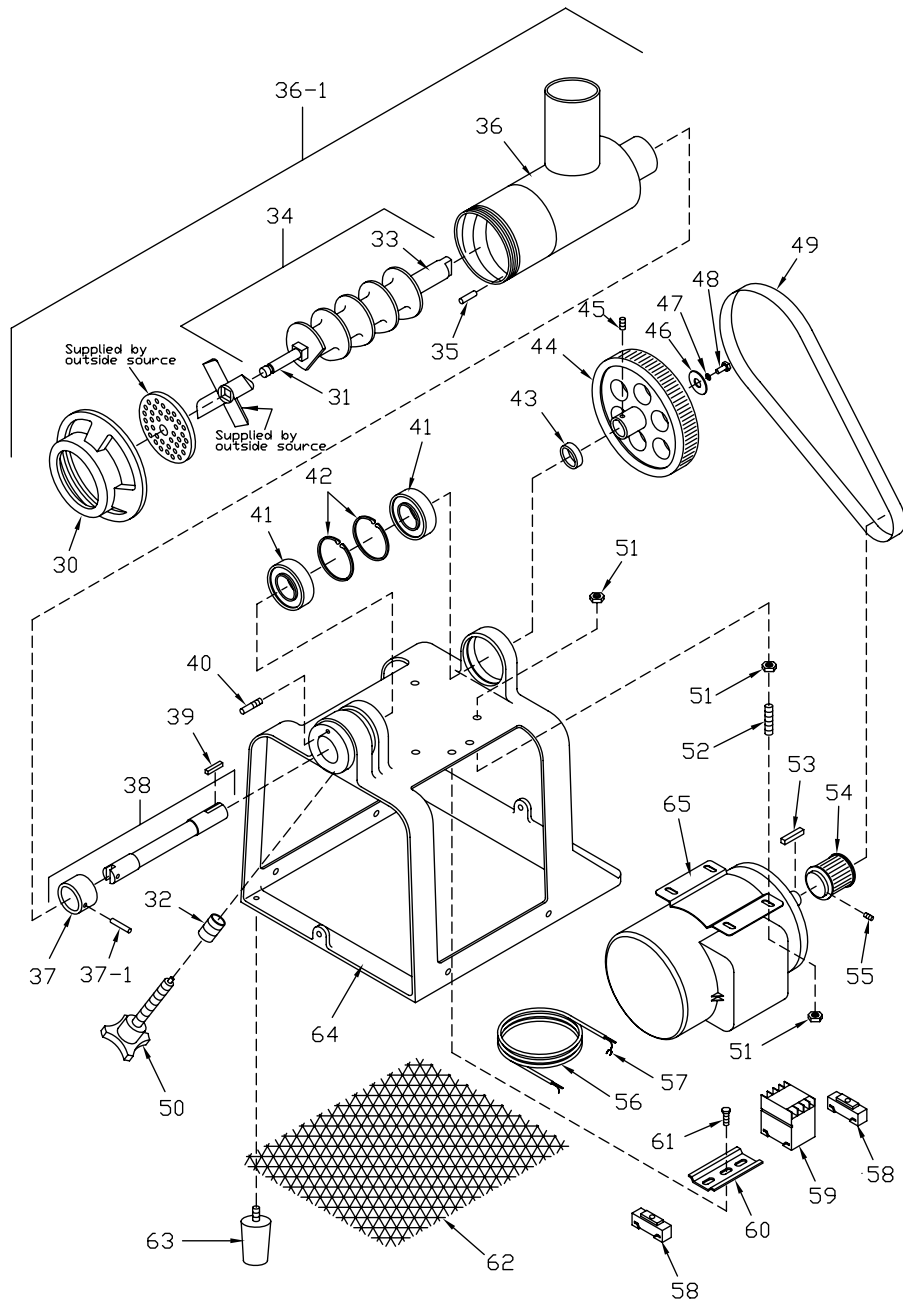

MODEL 8-12 MISC. PARTS C657-111 Owner/operating manual

For 8-12 Units from S/N: 5200 to S/N: 10222

Footnote "A": Use **C12K** Bowl w/ Tray Replacement Kit consisting of: **CC12** Bowl, **C612-1** Tray and **C606-1** Stomper.

Footnote "B": Use **C12KA** Bowl Assembly w/ Tray and Stomper Replacement Kit consisting of: **CC12A** Bowl Assembly, **C612-1** Tray, and **C606-1** Stomper.

MODEL 8-22 MISC. PARTS C657-111 Owner/operating manual

For 8-22 Units from S/N: 5200 to S/N: 10377

Footnote "C": Use **C22K** Bowl w/ Tray Replacement Kit consisting of: **CC22** Bowl, **C612-1** Tray and **C606-1** Stomper.

Footnote "D": Use **C22KA** Bowl Assembly w/ Tray and Stomper Replacement Kit consisting of: **CC22A** Bowl Assembly, **C612-1** Tray, and **C606-1** Stomper.

BOWL, FRAME & MOTOR PARTS LIST

Starting with Serial No.5200, No. C84001 and No. C84859 with HTD Drive Belt.

(This Catalog does not pertain to 8-12/8-22 with Plastic Gears)

NOTE: SPECIFY MODEL & SERIAL NUMBER WHEN ORDERING PARTS

MODEL 8-12 PARTS LIST

Fig.	Item No.	Description
30	CR12	Bowl ring
31	CK12	Knife drive pin
32	C662	Heli-coil insert, 1/2" (8351 on)
33	C670	Worm drive shaft, (10222 on)
	C736	Worm drive shaft, (before 10222)
34	CS12A	Worm Assembly, (10222 on)
	CS12A-OS	Worm Assembly, (before 10222)
35	CP12	Bowl pin, 5/32 x 1 1/8"
36	CC12	Safety bowl w/ pin (10222 on)
	C731	Safety bowl (before 10222) N/A See Footnote "A", page 10
36-1	CC12A	Safety bowl assembly, (10222 on)
	CA731	Safety bowl assembly (before 10222) N/A, See Footnote "B", page 10
37	C609	Main drive shaft collar, (10222 on) See fig 38
37-1	C622	Main drive shaft collar pin
38	C610-1AK	Main drive shaft assembly, (C#-84859 on)
	C610A	Main drive shaft assbly, (10222 to C#-84858)
39	C617	Main drive gear key
40	C600	Bowl locator pin
41	C629	Main bearing, 2 required
42	C632	Bearing retaining ring, 2 required
43	C607-1	Main drive shaft spacer, (C#-84859 on)
	C607	Main drive shaft spacer, (10222 to C#-84858) Use C607-1

MODEL 8-22 PARTS LIST

Fig.	Item No.	Description
30	CR22	Bowl ring
31	CK22	Knife drive pin
32	C662	Heli-coil insert, 1/2" (8351 on)
33	C670	Worm drive shaft, (10377 to C#-86673)
	C937	Worm drive shaft, (before 10377)
34	CS22A-R1	Worm Assembly, (10377 on)
	CS22A-OS	Worm Assembly, (before 10377)
35	CP22	Bowl pin, 3/16 x 1 1/8"
36	CC22	Safety bowl w/ pin (10377 on)
	C932	Safety bowl (before 10377) N/A See Footnote "C", page 10
36-1	CC22A	Safety bowl assembly, (10377 on)
	CA932	Safety bowl assembly (before 10377) N/A, See Footnote "D", page 10
37	C609	Main drive shaft collar, (10377 on) See fig 38
37-1	C622	Main drive shaft collar pin
38	C610-1AK	Main drive shaft assembly, C#-84859 on
	C610A	Main drive shaft assbly, (10377 to C#-84858)
39	C617	Main drive gear key
40	C600	Bowl locator pin
41	C629	Main bearing, 2 required
42	C632	Bearing retaining ring, 2 required
43	C607-1	Main drive shaft spacer, (C#-84859 on)
	C607	Main drive shaft spacer, (10377 to C#-84858) Use C607-1

MUTUAL PARTS LIST

44	C919	Main drive sprocket, aluminum (60Hz/148 tooth) (C#-84859 on)	54	C920A	Motor sprocket, aluminum (50-60 Hz/28 tooth) (C#-84859 on)
	C919-1	Main drive sprocket, aluminum (50Hz/123 tooth) (C#-84859 on)		C620	Motor pinion gear (60 cycle/13 tooth) N/A (before C#-84859), Order Kit, C919K
	C619	Main drive gear (70 tooth- 1" CG) N/A (before C#-84859), Order HTD Kit		C620-1	Motor pinion gear (50 cycle/15 tooth) N/A (before C#-84859), Order Kit, C919-1K
45	H405	Socket set screw, 5/16-18 x 3/8", 2 req'd (C#-84859 on) OR SSS17KL	55	C920D	Socket set screw, 8-32 x 1/4", 2 required
	SSS13	Set screw 1/4-20 x 3/8", (before C#-84859)	56	C645	Main cord, 3 phase (14/4 SO)
46	C916	Flat washer 25/64 ID x 1 3/4" OD, SS		C645-1	Main cord, 1 phase (14/3 SO)
47	LW20S	Lock washer, 3/8", SS	57	C774	Connector to McGill switch, 2 required
48	HHS067S	Hex head screw, 3/8-16 x 3/4", SS	58	C981	Din rail, End clip, 2 required
49	C921	HTD drive belt (60Hz) 800-5M-30 (C#-84859 on)	59	C903	110V contactor (AEG LS07) 1 phase
	C921-1	HTD drive belt (50Hz) 710-5M-30 (C#-84859 on)		C903-1	220V contactor (AEG LS07) 1 & 3 phase
	C621	Drive chain (1" wide x 3/8 pitch x 78 links) N/A (5200 to C84858), Order HTD Kit		C643	Round head grounding screw, 10-24 x 1/2"
50	C601A	Bowl lock handle assembly, 1/2" (8351 on)	60	C981-1	Din rail
	C601B	Bowl lock handle assembly, 3/8" (5200-8350)	61	HHS035S	Hex head screw, 5/16-18 x 3/4"
51	HN20S	Heavy hex nut, 5/16-18, motor mount 12 required	62	C654	Safety screen
			63	TA3111	Rubber foot assembly, 4 required
52	C638	Motor mount to frame studs, (5/16-18 x 1 1/2")	64	C614	Frame, aluminum (5200 on)
53	C931	Motor shaft key, (3/16 x 3/16 x 1 3/8")	65	C930-2	1 HP (220/440-50/60-3) Baldor
				C930-3	HP (104/208-60-1) Baldor
				C930-4	1 HP (115/230-60-1) Baldor
				C930-5	1 HP (240-50-1) Baldor

HTD KITS

C919K	HTD Drive belt kit (60 Hz/148 tooth) Includes: C919, C920A, C921
C919-1K	HTD Drive belt kit (50 Hz/123 tooth) Includes: C919-1, C920A, C921-1

NOT SHOWN

C767	Power cord (UL & CSA) 1 phase
------	-------------------------------

WIRING DIAGRAMS - 1 PHASE

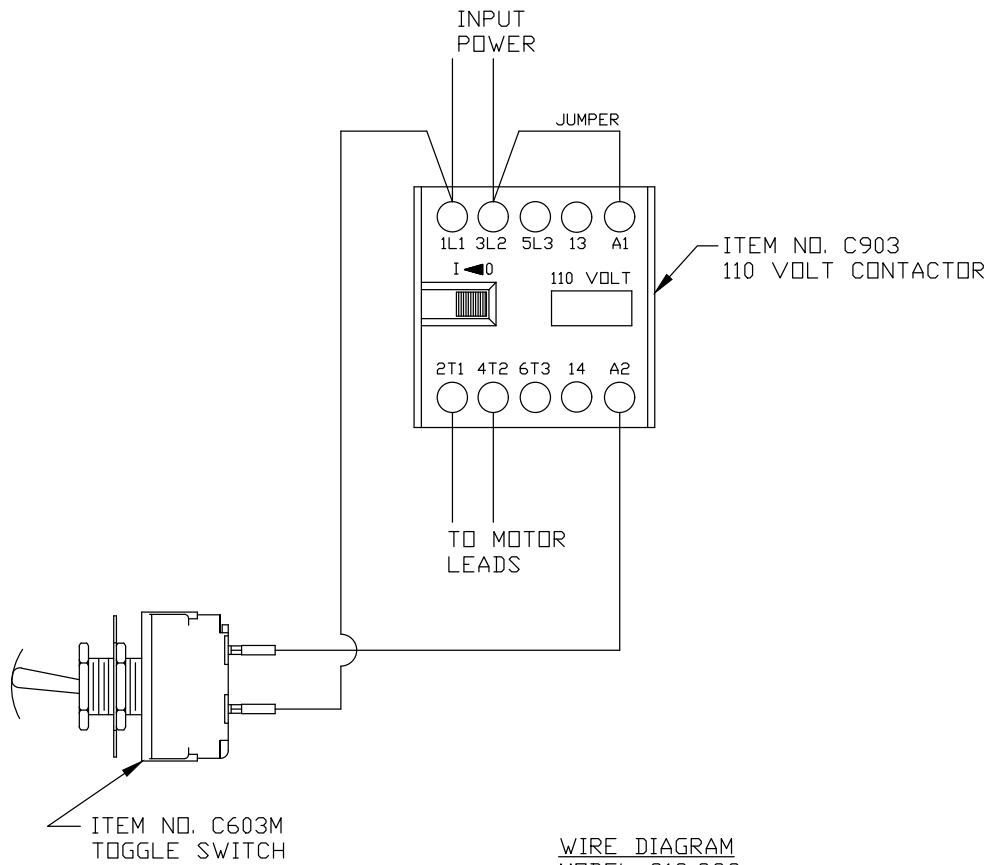

WIRE DIAGRAM
MODEL 812,822
110 VOLT, 1 PHASE

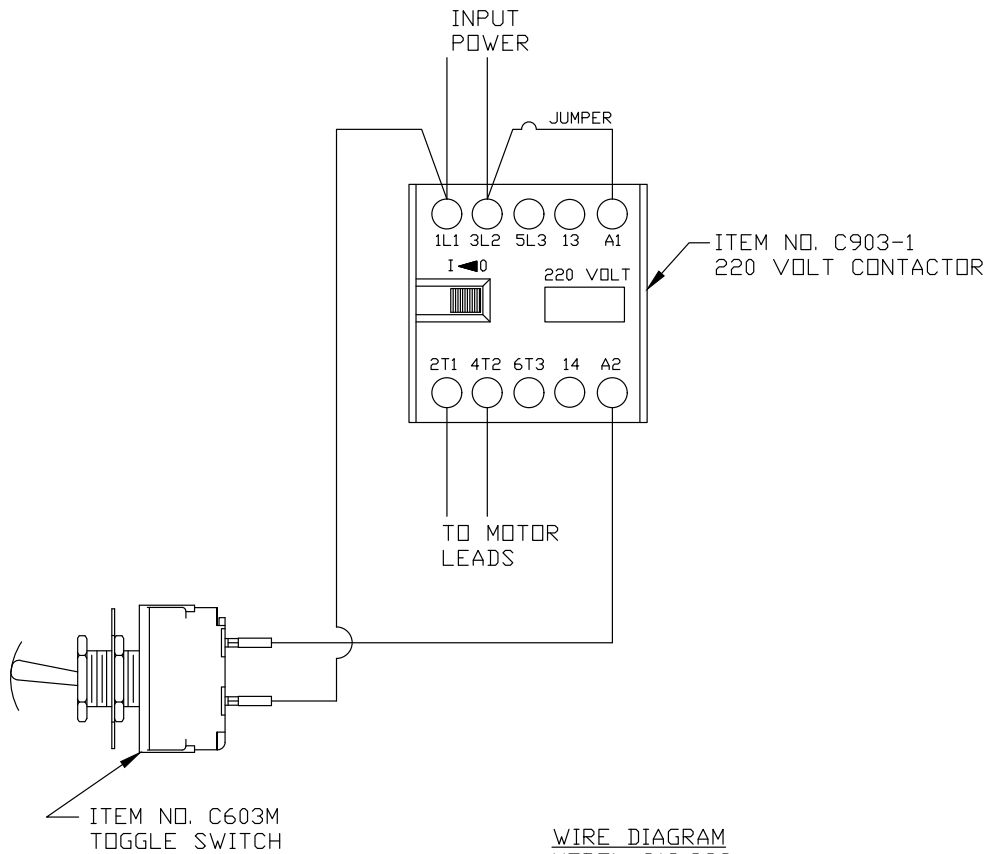

WIRE DIAGRAM
MODEL 812,822
220 VOLT, 1 PHASE

WIRING DIAGRAMS CONTINUED - 3 PHASE

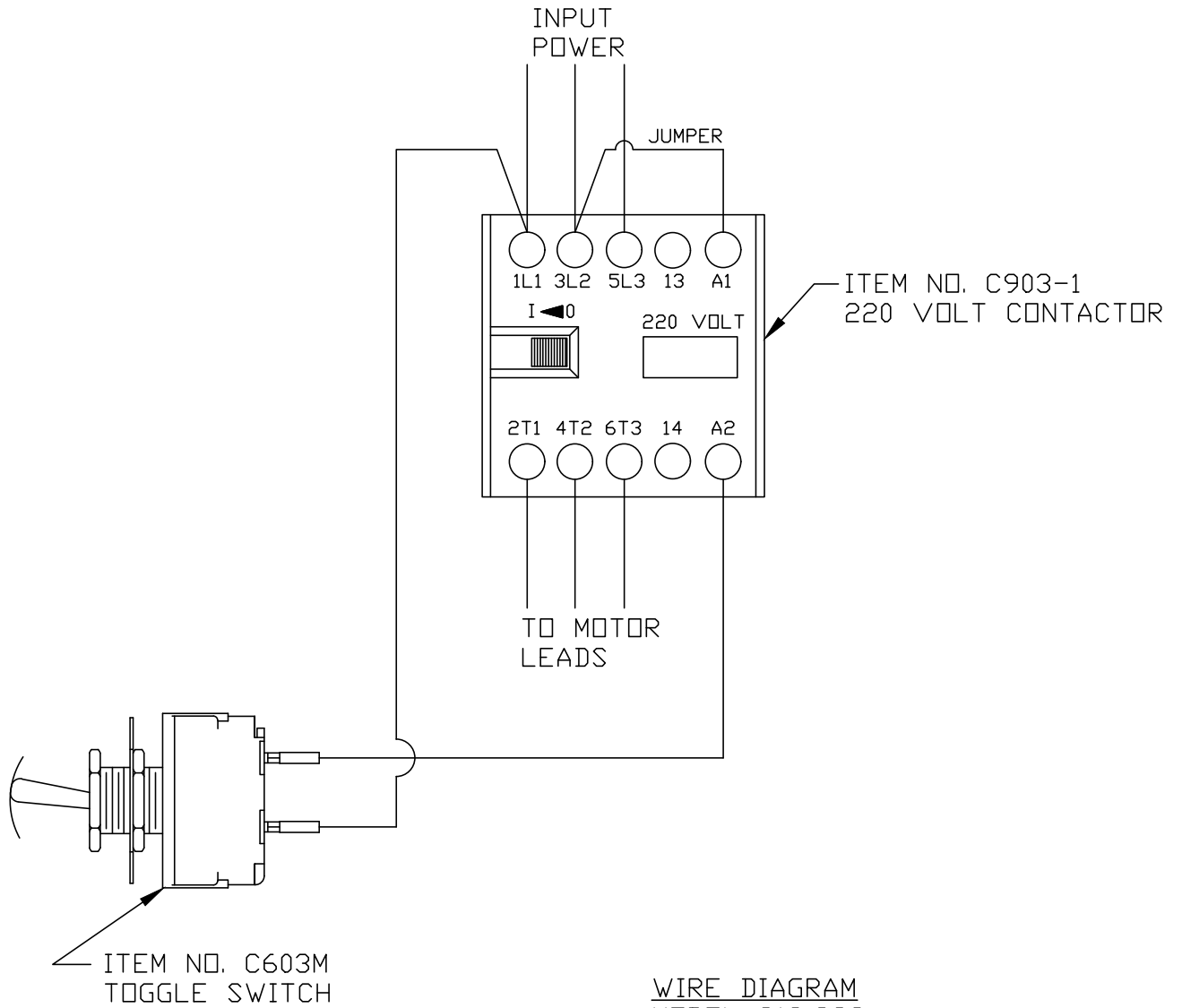

WIRE DIAGRAM
MODEL 812,822
220 VOLT, 3 PHASE

-OPERATOR'S NOTES-

LIMITED WARRANTY

WARRANTY: The BIRO Manufacturing Company warrants that the BIRO Model 8-12 and 8-22 Grinders will be free from defects in material and workmanship under normal use and with recommended service. BIRO will replace defective parts, which are covered by this limited warranty, provided that the defective parts are authorized for return, shipping charges prepaid, to a designated factory for inspection and/or testing.

DURATION OF WARRANTY: The warranty period for all parts covered by this limited warranty is one (1) year from date of Inspection/Demonstration as advised on the returned Warranty Registration card, or eighteen (18) months from original factory shipping date, whichever date occurs first, except as noted below.

PARTS NOT COVERED BY WARRANTY: The following are **not** covered by this limited warranty: wearable parts in the grinding system such as the bowl, worm drive shaft, ring, worm, and knife drive pin. This limited warranty does not apply to machines sold as used, rebuilt, modified, or altered from the original construction in which the machine was shipped from the factory. Water contaminated electrical systems are not covered under this limited warranty. BIRO is not responsible for electrical connection of equipment, adjustments to switch components or any other electrical requirements, which must be performed only by a certified electrician. BIRO is not responsible for service charges or labor required to replace any part covered by this limited warranty or for any damages resulting from misuse, abuse, lack of proper or recommended service.

EXCLUSION OF WARRANTIES AND LIMITATION OF REMEDIES: BIRO gives no warranties other than those expressly stated in this limited warranty. THE IMPLIED WARRANTY OF MERCHANTABILITY, THE IMPLIED WARRANTY OF FITNESS FOR PROCESSING OF FOOD PRODUCTS, AND ALL OTHER IMPLIED WARRANTIES ARE SPECIFICALLY EXCLUDED. BIRO IS NOT LIABLE FOR CONSEQUENTIAL OR INCIDENTAL DAMAGES, EXPENSES OR LOSSES. THE REMEDIES PROVIDED IN THIS BIRO LIMITED WARRANTY ARE PURCHASER'S SOLE AND EXCLUSIVE REMEDIES AGAINST BIRO.

REGISTRATION CARDS: You must sign, date and complete the warranty registration card supplied with each machine. The warranty card must be returned to The Biro Manufacturing Company for proper registration. If no warranty card is returned to BIRO, the warranty period will begin from the date the machine was originally shipped from the factory.

HOW TO GET SERVICE:

1. Contact the agency from whom you purchased the machine; or
2. Consult the yellow pages of the phone directory for the nearest authorized dealer; or
3. Contact Biro Mfg. Company for the nearest authorized service entity in your area.

BIRO MANUFACTURING COMPANY

1114 West Main St.

Marblehead, OH 43440 U.S.A.

Telephone: 419-798-4451 Fax: 419-798-9106

E-mail: service@birosaw.com; <http://www.birosaw.com>