



Model AFMG-24 MINI AUTOMATIC MIXER GRINDER/CHOPPER



OPERATING
AND
SERVICE
MANUAL

☆ IMPORTANT NOTICE ☆

This Manual contains important safety instructions which must be strictly followed when using this equipment.

Item No. 56224
Form No. AFMG24-220-1-16-16-B

TABLE OF CONTENTS:

	PAGE
NOTICE TO OWNERS AND OPERATORS	1
SAFETY TIPS	2
INSTALLATION	3
UNCRATING AND SETUP	3
MOTOR WIRING AND ELECTRICAL REQUIREMENTS	4-5
MOTOR SPECIFICATIONS	4
OPERATION	6
TO PROCESS PRODUCT	6
CLEANING	7
MAINTENANCE	8
MIXING PADDLE INSTALLATION	8
LUBRICATION	8
WIRING DIAGRAMS, 1 & 3 PHASE	9
PARTS DIAGRAMS	10
FRAME & CASE	10
MIXER	11
GRINDER	11
POWER TRANSMISSIONS	12-15
POWER CONTROLS (ELECTRICAL)	16
RETROFIT AEG CONTACTORS IN CONTROL BOX	17
OPTIONAL STAINLESS STEEL BOWLS, AUGERS & RINGS (114mm UNGER & ENTERPRISE)	18
ITEMS REQUIRED FOR TANDEM OPERATION	19
FOOTSWITCHES, PNEUMATIC & ELECTRIC	20-21
OPTIONAL EQUIPMENT ILLUSTRATED	22
WARNING LABEL LOCATIONS ON MACHINE	23
TANDEM OPERATION ILLUSTRATION FOR 90° INLET	24
TANDEM CONNECTION ILLUSTRATION	25
OPERATOR SIGNATURE PAGE	26
OPERATOR'S NOTES	27
LIMITED WARRANTY	28

NOTICE TO OWNERS AND OPERATORS

BIRO's products are designed to process food products safely and efficiently. Unless the operator is properly trained and supervised, however, there is the possibility of a serious injury. It is the responsibility of the owner to assure that this machine is used properly and safely, strictly following the instructions contained in this Manual and any requirements of local law.

No one should use or service this machine without proper training and supervision. All operators should be thoroughly familiar with the procedures contained in this Manual. Even so, BIRO cannot anticipate every circumstance or environment in which its products will be used. You, the owner and operator, must remain alert to the hazards posed by the function of this equipment particularly the ROTATING GRINDING AUGER and the ROTATING MIXING PADDLE, which can severely injure an inattentive operator amputating fingers and limbs. No one under eighteen (18) years of age should operate this equipment. If you are uncertain about a particular task, ask your supervisor.

This Manual contains a number of safe practices in the SAFETY TIPS section. Additional warnings are placed throughout the Manual. Warnings relate to your personal safety are indicated by:



or



Warnings related to possible damage are indicated by:



BIRO also has provided warning labels on the equipment. If any warning label, instruction label or Manual becomes misplaced, damaged, or illegible, please contact your nearest Distributor or BIRO directly for a replacement.

Remember, however, this Manual or the warning labels do not replace the need to be alert and to use your common sense when using this equipment.

This Manual applies to all machines with serial number 20200 and higher.

- NOTE -

A copy of this manual is included with each MODEL AFMG-24 MIXER GRINDER.

**The descriptions and illustrations contained in this manual are not binding.
The manufacturer reserves the right to introduce any modification without updating the manual.**

SAFETY TIPS

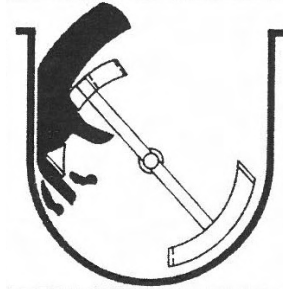

ROTATING GRINDING AUGER & ROTATING MIXING PADDLE TO AVOID SERIOUS PERSONAL INJURY

- **NEVER** Touch This Machine without Training and Authorization by Your Supervisor.
- **NEVER** Place Hands into Machine Input or Output Openings.
- **NEVER** Open Machine During Operation.
- **ONLY** Use a Qualified Electrician to Install According to Local Building Codes: Machine **MUST** Be Properly Grounded.
- **ALWAYS** Connect to **PROPER** Voltage & Phase.
- **ONLY** Install on Level, Non-Skid Surface in a Clean, Well-Lighted Work Area Away from Children and Visitors.
- **ALWAYS** Lock Machine Castors After Moving This Machine.
- **NEVER** Use This Machine For Non-Food Products.
- **NEVER** Operate Machine With Product Mixer Safety Cover Open or Removed or Magnetic Interlock Switch By-Passed.
- **ALWAYS** Turn Off, Unplug Machine From Power Source and Perform Lockout/Tagout Procedure to this Machine **BEFORE** Attempting to Unjam or Unclog, Cleaning or Servicing.
- **NEVER** Leave Machine Unattended While Grinder is Running.
- **NEVER** Alter This Machine From its Original Form as Shipped From Factory. **DO NOT** Operate Machine With Missing Parts.
- **PROMPTLY REPLACE** Any Worn or Illegible Warning Labels.
- **ALWAYS** Read Operation and Service Manual **BEFORE** Operating, Cleaning, or Servicing.
- **USE ONLY BIRO** Parts and Accessories Properly Installed.

INSTALLATION



TO AVOID SERIOUS PERSONAL INJURY, PROPERLY INSTALL EQUIPMENT IN ADEQUATE WORK AREA

- **ALWAYS** Use Qualified Technician and Electrician for Installation.
- **ALWAYS** Connect to **Proper** Voltage & Phase.
- **ALWAYS** Install Equipment in Work Area with Adequate Light and Space Away From Children and Visitors.
- **ONLY** Operate on a Solid, Level, Non-Skid Surface.
- **ALWAYS** Lock Machine Castors After Moving Machine to Operating Location.
- **NEVER** Bypass, Alter, or Modify This Equipment in Any Way From Its Original Condition.
- **NEVER** Operate Machine With Product Mixer Safety Cover Open or Removed or Magnetic Interlock Switch By-Passed.
- **NEVER** Operate Without all Warning Labels Attached and Owner/Operator Manual Available to the Operator.
- **USE ONLY BIRO** Parts and Accessories Properly Installed.

UNCRATING AND SET UP

1. Read this Manual thoroughly before installation and operation. **Do not** proceed with installation and operation if you have any questions or do not understand anything in this Manual. Contact your local Distributor, or **BIRO first**.
2. Remove all banding, shipping carton, and all equipment from inside the tub. Then take machine off shipping pallet.
3. This machine is shipped with the adjustable legs fully retracted. The legs allow for a height adjustment from the floor to centerline of bowl 24½” minimum to 34” maximum.
4. This machine weighs approximately 600 pounds. To avoid accidents block up machine after raising to desired operating height.
5. The adjustable legs can be unbolted and lowered to the floor. Replace bolts and nuts and tighten securely.
6. Install machine on a level, non-skid surface in a well-lighted work area away from children and visitors.
7. This machine is complete except for knife and plate. There is a bowl shipping plug (cardboard) placed in the output end of the grinding bowl to retain the grinding auger during shipment. **REMOVE THE BOWL SHIPPING PLUG AND THE GRINDING AUGER.**



8. After checking and making sure the power supply is correct, plug in your machine. **NEVER OPERATE MACHINE WITH PRODUCT MIXER SAFETY COVER OPEN.** (Machine will not run with cover open.)
9. Machine must be properly grounded. Use qualified electrician to install according to local building codes.

MOTOR WIRING AND ELECTRICAL REQUIREMENTS

1. Interchange of current is made in motor outlet box. Leads are properly marked. Changing instructions are on the motor plate or motor outlet box.
2. All grinders are wired 208/230 volts unless otherwise specified. Be sure motor specifications (voltage, cycle, phase) match power supply line. Be sure line voltage is up to specification.
3. Electrical connections to be in accordance with safety codes and National Electrical Code.
4. Rated voltage of the unit shall be identical with full supply voltage.
5. Voltage drop on the supply line shall not exceed 10% of full supply voltage.
6. The feederline conductor size in the raceway from the branch circuit to the unit must be correct to assure adequate voltage under heavy starting and short overload conditions.
7. The feederline conductor shall only be used for the supply of one unit of the relevant horsepower. For connections of more than one unit on the same feederline, a local electrician will have to be consulted to determine the proper conductor size.
8. The size of the electrical wiring required from the power source to the mixer grinder is a **MINIMUM OF No. 10 WIRE.**
9. The BIRO Manufacturing Company is not responsible for permanent wiring, connection or installation.



NOTE TO OWNER AND ELECTRICIAN: IF THIS MACHINE IS NOT CORD AND PLUG CONNECTED TO THE ELECTRICAL SUPPLY SOURCE, THEN IT SHOULD BE EQUIPPED WITH, OR CONNECTED TO, A LOCKABLE, MANUALLY-OPERATED DISCONNECT SWITCH (OSHA 1010.147)

MOTOR SPECIFICATIONS

HP	KW	VOLTS	HZ	PH	AMPS
5	4	208/230	60	3	13.4/12.6
5	4	208/230	60	1	25/22.8
5	4	460	60	3	6.3
5	4	550	60	3	5.5
7.5	5.6	208/230	60	3	21.5/20
7.5	5.6	220	50	3	22
7.5	5.6	380/415	50	3	12.7/11.6
7.5	5.6	460	60	3	10
7.5	5.6	550	60	3	8.5

10. Located on the side of the machine are a green and red pushbutton for activating the internal motor control contactor. The magnetic interlock switch is mounted under the rear machine cover. It lines up with the magnet attached to the product mixer safety cover. When the safety cover is raised the machine will stop operation.
11. Push the green start button. **CHECK THE ROTATION OF THE MIXING PADDLE; ROTATION MUST BE COUNTER-CLOCKWISE** as indicated by the rotation decal affixed to the mixer paddle front mounting hub. Backwards operation will not allow mixing paddle to feed product to the grinding auger efficiently.
12. Lift slightly the clutch arm and push to the rear of the machine. **CHECK THE ROTATION OF THE AUGER; ROTATION MUST BE COUNTER-CLOCKWISE** as indicated by the rotation decal located on the grinding bowl. **ROTATION MUST ONLY BE CHECKED WITH THE GRINDING AUGER REMOVED**, otherwise serious irreparable damage may occur to grinding components.



13. If machine runs clockwise(backwards), it must be rewired to correct rotation, otherwise serious irreparable damage may occur to the grinding components. Both the auger and the mixing paddle must operate in the proper direction.
14. Check operation of optional footswitch if equipped. Plug footswitch cord into fitting on control panel. Turn selector to foot. The machine will operate with pressure on the footswitch treadle. Releasing the treadle stops the machine.
15. Insert auger assembly into the grinding bowl and fully engage the auger into the drive shaft. Place knife first (sharp edges out) then grinding plate into end of grinding bowl. The grinding plate slides over the knife drive pin, and is held from rotating during operation by three pins in the grinding bowl. Install the end retaining ring.



ONLY HAND TIGHTEN END RETAINING RING

For best results, use knife and plate as a set. Do not operate machine for any period of time without product in the grinding bowl. This will cause heating and dulling of the knife and plate.

16. Check placement of all warning labels and Manual. Machine is now ready for trained operators to process product.
17. Use meat deflector attached to grinding bowl to eliminate meat splatter.
18. Contact your local Distributor or BIRO directly if you have any questions or problems with the installation or operation of this machine.

OPERATION



ROTATING GRINDING AUGER & ROTATING MIXING PADDLES TO AVOID SERIOUS PERSONAL INJURY

- **ONLY** Properly Trained Personnel Should Use This Equipment.
- **NEVER** Place Hands into Machine Input or Output Openings.
- **NEVER** Open Machine During Operation.
- **DO NOT** Wear Gloves While Operating.
- **DO NOT** Tamper With, Bypass, Alter, or Modify This Equipment in Any Way From Its Original Condition.
- **NEVER** Operate Machine With Product Mixer Safety Cover Opened or Removed or Magnetic Interlock Switch By-Passed.
- **ALWAYS** Turn Off and Unplug Machine from Power Source and Perform Lockout/Tagout Procedure to This Machine **Before** Attempting to Unjam, Unclog, Cleaning or Servicing.
- **NEVER** Leave Machine Unattended While the Grinder is Running.
- **NEVER** Operate Without All Warning Labels Attached and Owner/Operator Manual Available to the Operator.

A. TO PROCESS PRODUCT

1. Before starting the mixer grinder, have a container for receiving ground product at the output end of the grinding bowl.
2. **FIRST GRIND**
 - a. Fill Product Hopper (Maximum 140 Pounds), close Product Mixer Safety Cover.
 - b. Push the green start button and shift the clutch arm into the grind position to feed first grind. It is recommended to use a breaker plate with a 3/8" diameter or larger holes.
 - c. Push the red stop button and pull the clutch arm out of the grind position when all product has been ground out.
3. **SECOND GRIND**
 - a. Fill Product Hopper (Maximum 140 Pounds), close Product Mixer Safety Cover.
 - b. Push the green start button. During this mix operation seasonings may be added through the sight holes in the Product Mixer Safety Cover.
 - c. After the desired mix, shift the clutch arm into the grind position to operate the grinding auger and grind out the product.
 - d. Push the red stop button when all product has been ground out.
4. Unplug machine from power source and perform lockout/tagout procedures.

DO's

- Always keep knife & plate as matched set.
- Always keep the knife & plate sharp.
- Always check for straightness by laying the knife on the plate before inserting in machine.
- Always install the knife & plate in correct sequence, knife 1st, then plate.
- Always keep knives & plates lubricated in storage and when starting machine.
- Always use coolant when sharpening plates.
- Always inspect the plates making sure all holes are clear - that there are no cracks.

DONT's

- Never, never mix different knives to different plates.
- Never, never over tighten the bowl retaining ring on the machine.
- Never, never run the grinder without product. Product is a natural lubricant. Heat can build up so fast that cold product could crack the plate.
- Never, never hit the plate against anything to clean the holes.
- Never, never throw the knives & plates.

CLEANING



ROTATING GRINDING AUGER & ROTATING MIXING PADDLES TO AVOID SERIOUS PERSONAL INJURY

- **ALWAYS** Turn Off, Unplug Machine From Power Source and Perform Lockout/Tagout Procedure to this Machine **BEFORE** Cleaning or Servicing.
- **ONLY** Use Recommended Cleaning Equipment, Materials, and Procedures.
- **NEVER** Spray Water or Other Liquid Substances Directly at Motor, Power Switch or any Other Electrical Components.
- **ALWAYS** Thoroughly Clean Equipment at Least Daily.

CLEANING THE BIRO MIXER-GRINDER

1. Disconnect mixer grinder from power-source and perform lockout/tagout procedures.
2. Remove grinding bowl end ring, breaker plate, knife and grinding auger.
3. Remove mixing paddle. Be sure front most paddle arm is pointing up. Loosen the thumb screw on the mixer paddle lock arm (Item No. 53853). While supporting the mixing paddle, remove the lock arm. Turn the mixing paddle counterclockwise, slide forward to disengage the drive shaft and lift from product hopper.



DO NOT POWER SPRAY DIRECTLY AT ELECTRICAL COMPONENTS

4. Machine is now ready to be cleaned using warm soapy water and rinsed with clean water. Machine may be cleaned by power spray washing, taking care not to spray directly at any electrical controls.
5. After machine has been cleaned and allowed to air dry, all exposed metal surfaces should be coated with a good food grade light oil or grease.

CLEANING THE BOWL- RING AND WORM CARE OF TIN COATED PRODUCTS (DO'S AND DON'TS)

1. Do not use abrasive cleaning materials, such as brillo pads or metal scrapers. Tin is a soft metal and should be cleaned with a soft cloth and dried.
2. Do not use a cleaning agent containing a high percentage of free alkali or acid.
3. Do not use a detergent containing a high percentage of tri-sodium phosphate or meta-silicate. Tin is reactive to both.
4. Rinse well and dry thoroughly after washing to remove agents that may be reactive to tin.
5. If sterilizing agent containing chlorine is used, the tinned surface must be thoroughly rinsed. Chlorine is corrosive to tin.
6. Dry thoroughly after rinsing and store in a dry environment.
7. If water is exceptionally hard, drying will be necessary to prevent spotting.

MAINTENANCE



ROTATING GRINDING AUGER & ROTATING MIXING PADDLES TO AVOID SERIOUS PERSONAL INJURY

- **ALWAYS** Turn Off, Unplug Machine From Power Source and Perform Lockout/Tagout Procedure to this Machine **BEFORE** Servicing.
- **NEVER** Touch This Machine without Training and Authorization by Your Supervisor.
- **NEVER** Place Hands into Machine Input or Output Openings.
- **NEVER** Bypass, Alter, or Modify This Equipment in Any Way From Its Original Condition.
- **PROMPTLY REPLACE** Any Worn or Illegible Warning Labels.
- **USE ONLY GENUINE BIRO** Parts and Accessories Properly Installed.

A. MIXING PADDLE INSTALLATION

1. Check that mixer paddle drive pin (Item No. [53516](#)) in the mixer paddle drive shaft (Item No. [53955](#)) is positioned vertically.
2. Holding the mixing paddle by the center shaft and with the front blade up carefully fit drive receiving collar onto the end of the drive shaft. Insert paddle lock arm assembly (Item No. [53852](#)) into the front of the mixing tub and onto the front of the mixing paddle.
3. When fully seated, turn the lock arm counterclockwise so the protruding arm is behind the lock set screw bracket. Tighten the mixer paddle lock set screw (Item No. [53568](#)).

B. LUBRICATION

1. **MOTOR:** This machine has pre-lubricated motor bearings. These bearings should be relubricated annually with a good grade of bearing grease. Do not over-grease.
2. **MAIN BEARINGS:** The main bearings are housed in an enclosed and sealed journal box. Relubricate semi-annually with a good grade of bearing grease. Do not over-grease.
3. **TRANSMISSIONS:** This machine is equipped with two Euclid gear reducer transmissions- one for the mixer drive (No. 300V) and one for the auger drive (No. CH300V). The mixer drive (300V) and the auger drive (CH300V) hold 1¼ pints of oil. This amount brings the lubricant level up to the side “fill level” hole. Oil should be changed after six (6) weeks of operation initially and subsequently every six (6) months thereafter using Mobil Gear 630 oil or Mobil 600W Super cylinder oil.

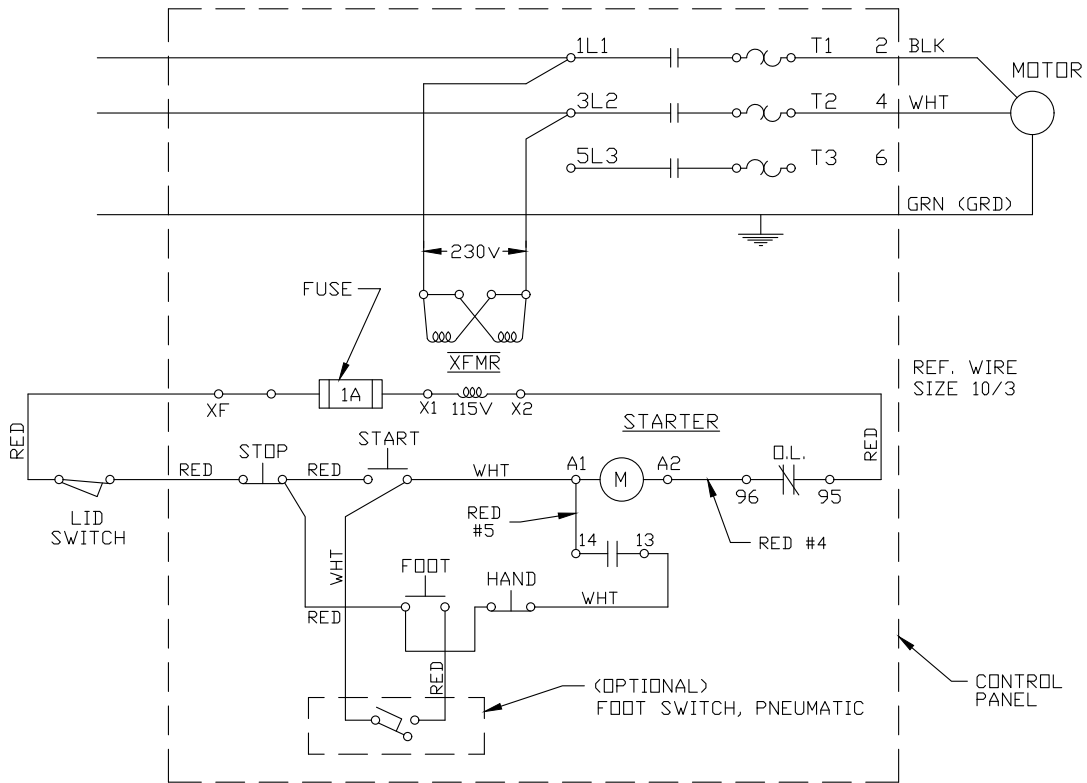

CONTROL SCHEMATIC AFMG-24
SINGLE PHASE

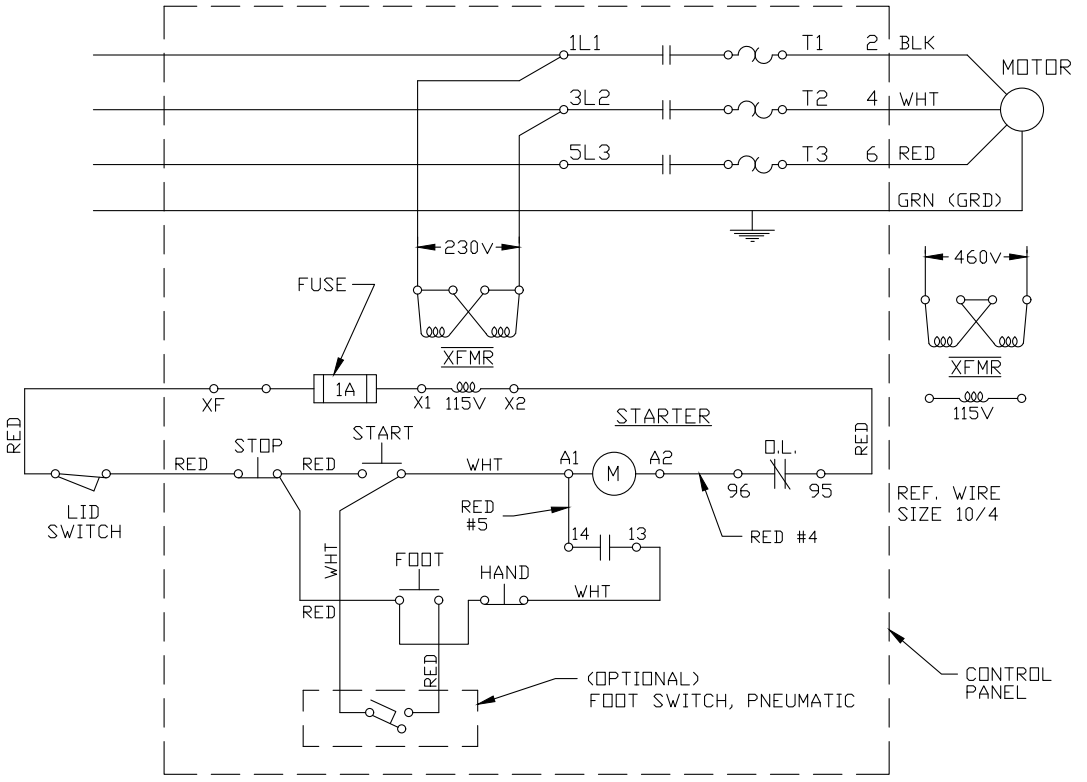

CONTROL SCHEMATIC AFMG-24
THREE PHASE

FRAME AND CASE

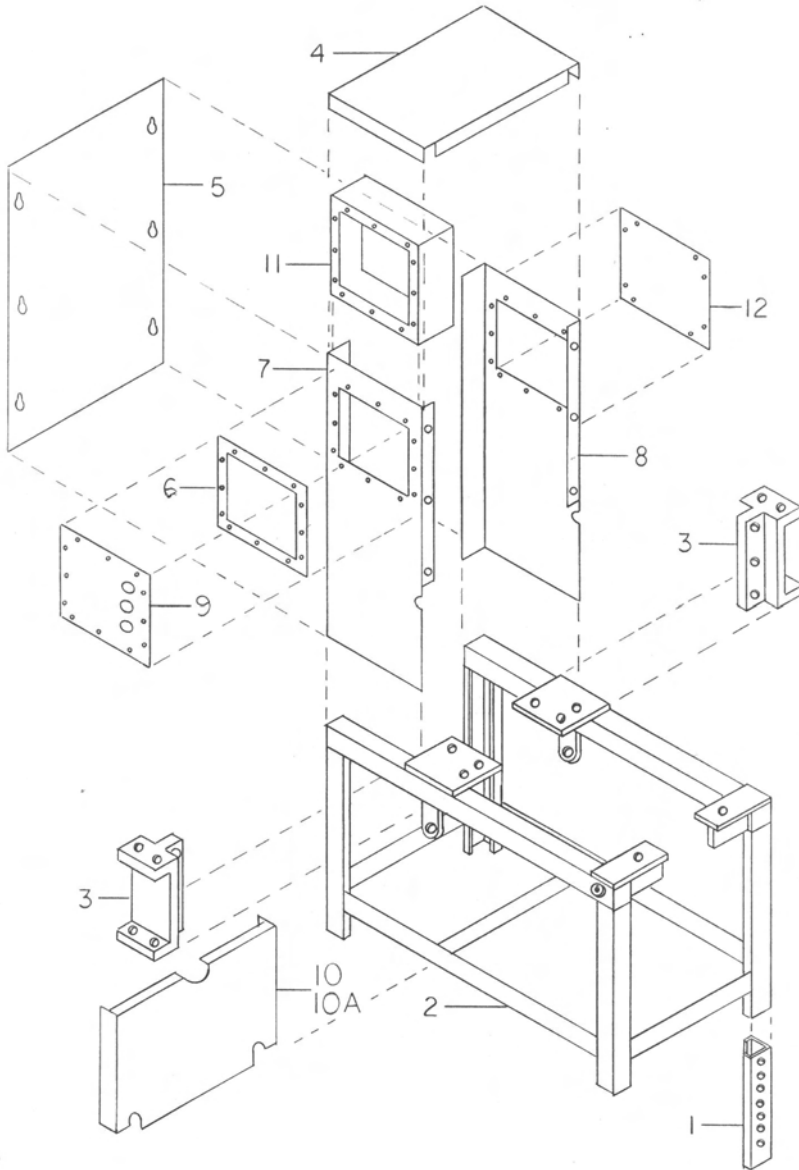

FRAME & CASE FASTENERS

ADJUSTABLE LEGS TO FRAME

Item No.

HHS067S Hex head screw, 3/8-16 x 3/4, SS, (8 ea.)

HN35S Hex nut, 3/8-16, SS, (8 ea.)

LW25S Lock washer, 3/8", SS, (8 ea.)

TRANSMISSION MOUNTING PLATE SUPPORTS TO FRAME

Item No.

HHS075S Hex head screw, 3/8-16 x 1 1/4, SS, (4 ea.)

LW20S Lock washer, 3/8, SS, (4 ea.)

S217C Dowel pin, 5/16 x 3/4, (4 ea.)

SIDE PANEL FILLER PLATE TO SIDE DRIVE COVER

Item No.

2563 Hex washer-head screw, 10-32 x 1/2, SS, (8 ea.)

LW05S Lock washer, #10, SS, (8 ea.)

HN10S Hex nut, 10-32, SS, (8 ea.)

CONTROL BOX COVER TO CONTROL BOX THROUGH DRIVE COVER

Item No.

2563 Hex washer-head screw, 10-32 x 1/2, SS, (12 ea.)

CONTROL BOX TO SIDE COVER

Item No.

2563 Hex washer-head screw, 10-32 x 1/2, SS, (2 ea.)

LW05S Lock washer, #10, SS, (2 ea.)

HN10S Hex nut, 10-32, SS, (2 ea.)

DRIVE COVER BACK TO DRIVE COVER

Item No.

HHS025S Hex head screw, 1/4-20 x 1/2, SS, (6 ea.)

LW10S Lock washer, 1/4", SS, (6 ea.)

DRIVE COVER TOP TO DRIVE COVER

Item No.

HHS025S Hex head screw, 1/4-20 x 1/2, SS, (4 ea.)

LW10S Lock washer, 1/4", SS, (4 ea.)

LOWER FRONT COVER TO SIDE DRIVE COVER

Item No.

HHS025S Hex head screw, 1/4-20 x 1/2, SS, (4 ea.)

LW10S Lock washer, 1/4", SS, (4 ea.)

DRIVE COVER SIDES TO FRAME

Item No.

HHS025S Hex head screw, 1/4-20 x 1/2, SS, (4 ea.)

LW10S Lock washer, 1/4", SS, (4 ea.)

DRIVE COVER SIDES TO TUB

Item No.

HHS055S Hex head screw, 5/16 x 3/4, SS, (6 ea.)

LW15S Lock washer, 5/16, SS, (6 ea.)

FW10S Flat washer, 5/16, SS, (6 ea.)

Fig.	Item No.	Description
1	56319/56320	Adjustable leg assembly, See Page 22
2	56240	Frame fabricated, SS, s/n: 20200 on
3	56062	Transmission mounting plate supports (2 req.)
4	56274	Drive cover top w/prox. switch mounting bracket, s/n: 20200 on
5	56165	Rear drive cover, s/n: 20026 on
6	56164	Seal for control box, s/n: 20026 on
7	56239	Drive cover, left side, s/n: 20200 on
8	56238	Drive cover, right side, s/n: 20200 on
9	56155	Control box cover, s/n: 20026 on
10	56089	Drive cover lower front, w/ lug holder cutouts
10A	56338	Drive cover lower front
11	56161	Control box, s/n: 20026 on
12	56144	Side panel filler plate s/n: 20026 on

NOT SHOWN

14572 Ring hanger

MIXER

Fig.	Item No.	Description
1	53568	Mixer paddle lock set screw
2	53594	Lock arm radial bearing
3	53517	Lock arm thrust bearing
4	53852	Lock arm assembly, w/ bearings
5	53953	Seal, mixer drive shaft thru tub
6	56039	Product mixer safety cover
7	56040	Product mixer tub, no side inlet
7A	56121	Product mixer tub, RH side inlet
7B	56124	Product mixer tub, LH side inlet
8	56044	Safety cover hinge rod
9	56045	Safety cover hinge rod spacer (2 ea.)
10	56072	Safety cover latch
11	56073	Latch mounting bracket, LH
12	56074	Latch mounting bracket, RH
13	56284	Product mixer paddle, 1st grind, SS
14	56221	Safety cover torsion spring, RH
15	56222	Safety cover torsion spring, LH
16	56273-1	Magnetic switch bracket & magnet
17	53853	Mixer paddle lock arm assembly
18	56230	Product mixer paddle, 2nd grind, SS, w/hook
NOT SHOWN		
	14572	Ring hanger

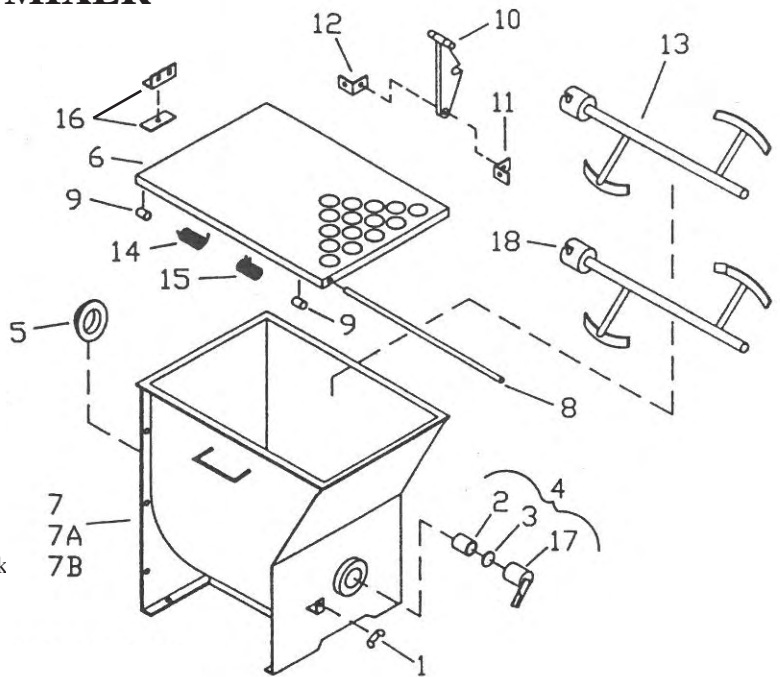

MIXER FASTENERS

HINGE ROD ENDS

Item No.

AN20S Acorn nut, 3/8-16, SS, (2 ea.)

LID LATCH TO LID

Item No.

RHS24S Round head screw, 1/4-20 x 1/2, SS, (2 ea.)

RHS31S Round head screw, 1/4-20 x 1, SS, (1 ea.)

HNNL15S Hex nut, nylok, 1/4-20, SS, (3 ea.)

MAGNET TO MOUNTING BRACKET

Item No.

FHS24S Flat head screw, 10-32 x 5/8, SS, (1 ea.)

LW05S Lock washer, #10, SS, (1 ea.)

HN10S Hex nut, 10-32, (1 ea.)

TUB TO FRAME

Item No.

HHS067S Hex head screw, 3/8-16 x 3/4, SS, (4 ea.)

LW20S Lock washer, 3/8, SS, (4 ea.)

GRINDER

Fig.	Item No.	Description
1	HK48	Knife drive pin
2	HR42/48	Bowl end ring
3	52392	Product splash shield
4	WN20S	Wing nut, 3/8-16
5	SSS45S	Stud, 3/8-16 x 1
6	57159K	Auger drive shaft seal kit
6A	57159	Auger drive shaft seal, double lip
6B	57160	Seal retainer, SS
6C	FHS26S	Flat head screw, 10-32 x 3/4, SS
7	54278-CTN	Auger assembly
8	54278B	Square drive insert
9	FHS33S	Shear pin screw
10	54278C	Auger shear pin
11	56049	Grinding bowl
12	56067	Torque link, (2 req.)
13	HP48	Bowl plate pins (3 req.)
14	H340	Ring wrench

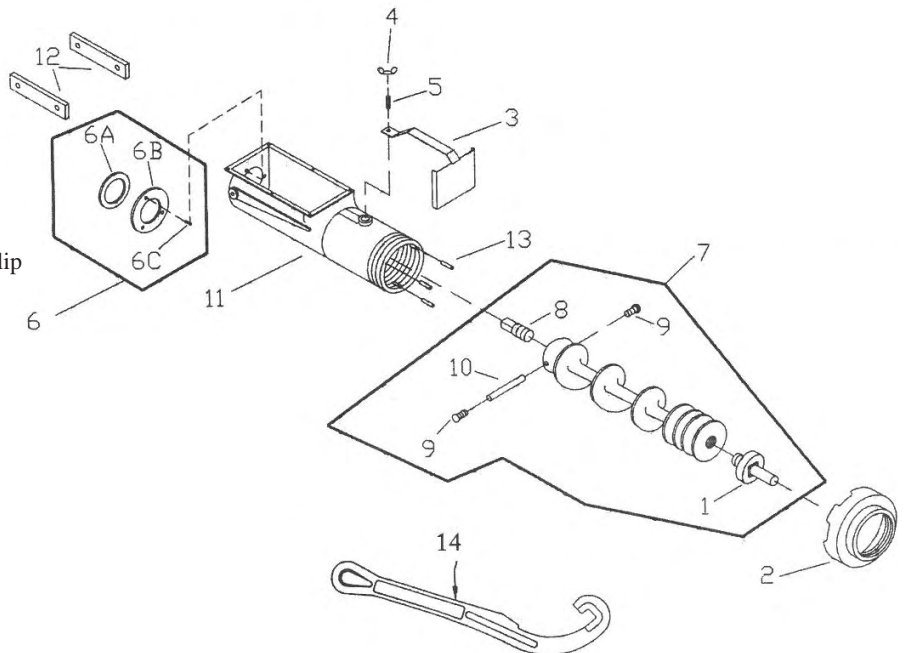

GRINDER FASTENERS

BOWL TO TUB

Item No.

HHS067S Hex head screw, 3/8-16 x 3/4, SS, (6 ea.)

LW20S Lock washer, 3/8, SS, (6 ea.)

S217C Dowel pin, 5/16 x 3/4, (2 ea.)

BOWL TO TORQUE LINK

Item No.

HHS126S Hex head screw, 1/2-13 x 1 1/4, SS, (2 ea.)

LW30S Lock washer, 1/2, SS, (2 ea.)

POWER TRANSMISSION

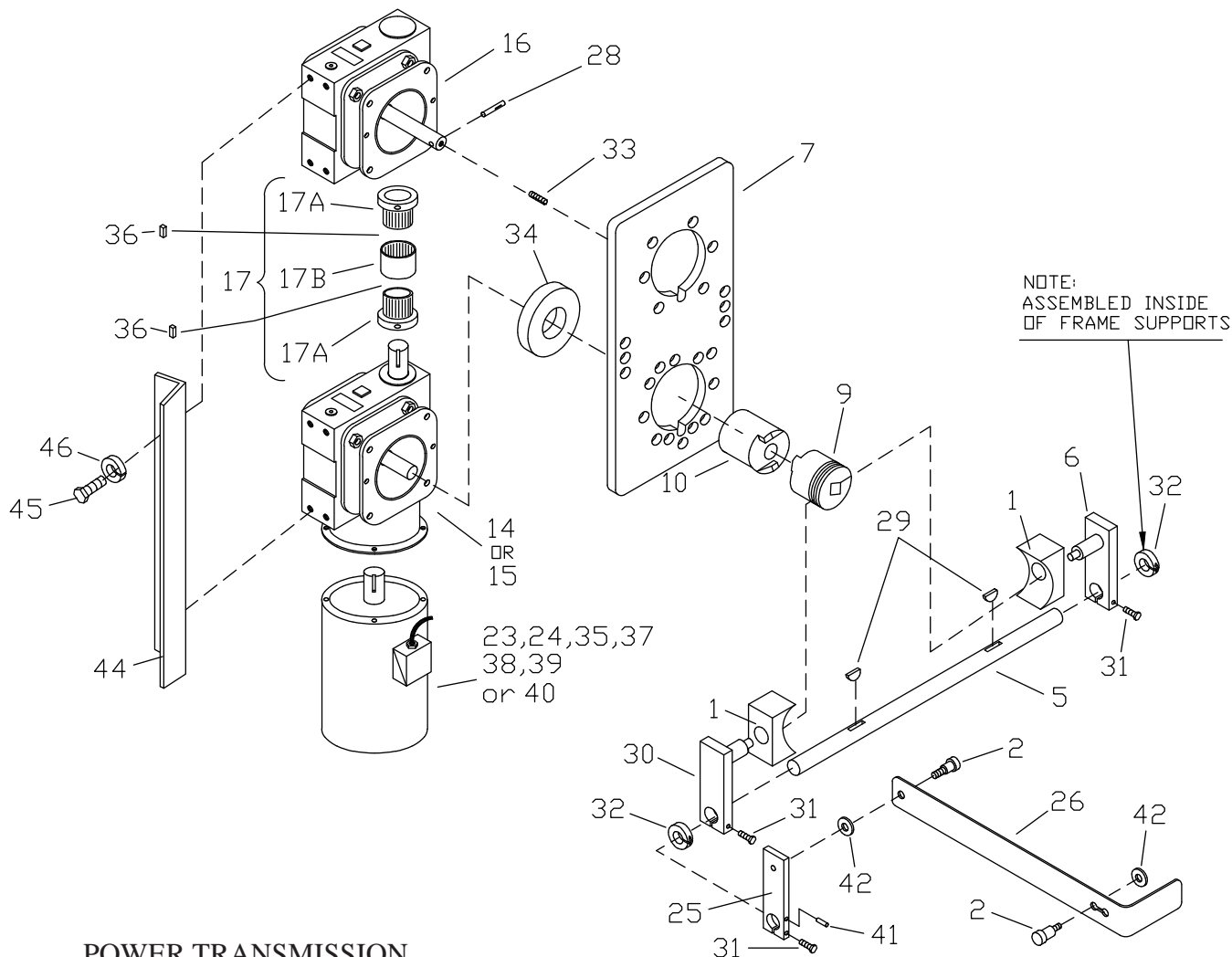

POWER TRANSMISSION FASTENERS

MIXER TRANSMISSION TO MOUNTING PLATE

Item No.

HHS126S Hex head screw, 1/2-13 x 1 1/4, SS, (4 ea.)

LW30S Lock washer, 1/2", SS, (4 ea.)

S217C Dowel pin, 5/16 x 3/4, (2 ea.)

GRINDER TRANSMISSION TO MOUNTING PLATE

Item No.

HHS126S Hex head screw, 1/2-13 x 1 1/4, SS, (4 ea.)

LW30S Lock washer, 1/2", SS, (4 ea.)

S217C Dowel pin, 5/16 x 3/4, (2 ea.)

TRANSMISSION MOUNTING PLATE TO MOUNTING PLATE SUPPORT

Item No.

HHS075S Hex head screw, 3/8-16 x 1 1/4, SS, (6 ea.)

LW20S Lock washer, 3/8, SS, (6 ea.)

S217C Dowel pin, 5/16 x 3/4, (2 ea.)

MOTOR TO TRANSMISSION

Item No.

HHS126S Hex head screw, 1/2-13 x 1 1/4, SS, (4 ea.)

LW30S Lock washer, 1/2, SS, (4 ea.)

LOVEJOY COUPLING TO TRANSMISSION SHAFTS

Item No.

SSS10Z Set screw, 1/4-20 x 1/4, (4 ea.)

JOURNAL BOX TO MOUNTING PLATE

Item No.

HHS070S Hex head screw, 3/8-16 x 1, SS, (4 ea.)

LW20S Lock washer, 3/8, SS, (4 ea.)

S217C Dowel pin, 5/16 x 3/4, (2 ea.)

DRIVING CLUTCH MOTOR OUTPUT TO TRANSMISSION SHAFT

Item No.

SSS17KL Set screw, knurled, cup 5/16-18 x 3/8, (3 ea.)

TORQUE LINK TO JOURNAL BOX

Item No.

HHS126S Hex head screw, 1/2-13 x 1 1/4, SS, (2 ea.)

LW30S Lock washer, 1/2", SS, (2 ea.)

CLUTCH ENGAGEMENT ARM TO CLUTCH ARM LOCK

Item No.

SSB50PS Shoulder bolt, 3/8-16 x 3/8, (2 ea.)

TRANSMISSION BRACE

Item No.

HHS126S Hex head screw, 1/2-13 x 1 1/4, SS, (4 ea.)

LW30S Lock washer, 1/2", SS, (4 ea.)

Fig.	Item No.	Description
1	56211-1	Driven clutch engagement bushing
2	SSB50PS	Shoulder bolt, $\frac{3}{8}$ -16 x $\frac{3}{8}$
3	H310A	Bearing assembly (journal box, front)
4	53785	Seal, journal box (front, auger drive)
5	56036	Driven clutch engagement shaft
6	56214	Driven clutch engagement lever, LH
7	56047	Mounting plate for transmission
8	56063	Journal box housing
9	56064	Driven clutch, square I.D.
10	56065	Driving clutch, transmission output
11	56066	Auger drive shaft, SS
12	56068	Spacer, (rear journal box)
13	56081	Journal box assembly complete
14	56095	Transmission, grinder, 60Hz, 8:1
15	56096	Transmission, grinder, 50Hz
16	56097	Transmission, mixer, 75:1
17	56276A	Coupling assembly complete
17A	56276	Coupling half
17B	56276B	Coupling sleeve
18	56100A	Bearing assembly (journal box rear)
19	56101	Castellated lockwasher
20	56102	Locknut
21	56103	Seal (rear journal box)
22	H307	Grease fitting, vented
23	56287	Motor 7½HP, 3Ph, 208-230/460V, 60Hz
24	56286	Motor 5HP, 3Ph, 208-230/460V, 60Hz
25	56270	Link engage handle
26	56288	Engage handle lock
28	53516	Mixer drive shaft pin
29	56127-1	Woodruff key
30	56215	Driven clutch engagement lever, RH
31	HHS061S	Hex head screw, 5/16-18 x 1¼, SS
32	56169	Driven clutch engagement shaft collar
33	SSS10Z	Set screw, ¼-20 x ¼
34	56258	Driven clutch Delrin back up spacer
35	56188	Motor 5HP, 1Ph, 208-230V, 60Hz
36	56133	Key, 3/16 x 3/16 x 1½
37	56132	Key, ¼ x ¼ x 1½
38	56259	Motor 5HP, 3Ph, 575V, 60Hz
39	56260	Motor 7½HP, 3Ph, 575V, 60Hz
40	56283	Motor 7½HP, 3Ph, 220/380-415V, 50Hz
41	MC-21R2	Groove pin, s/n: 20389 on
42	53659	Flat washer, s/n: 20405 on
43	ST73	Lock nut spanner wrench (shop tool)
44	56351	Transmission brace
45	HHS126S	Hex head screw, ½-13 x 1¼, SS
46	LW30S	Lock washer, ½, SS

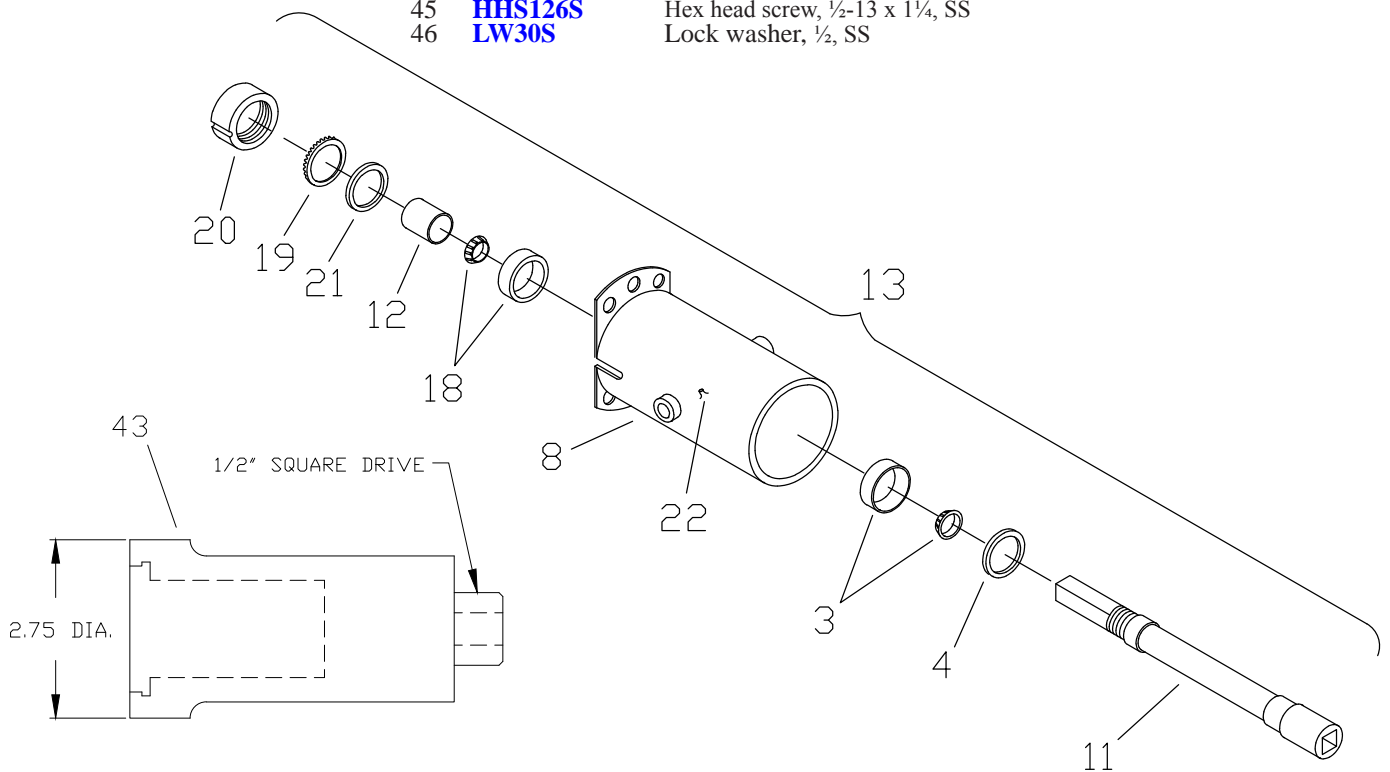

- 56097-A
- 56097-B
- 56097-BB
- 56097-C
- 56097-D
- 56097-DD
- 56097-E
- 56097-F
- 56097-G
- 56097-H
- 56097-J

- Output cap
- 3/8-16 x 1/4 hex head cap screws
- 3/8-16 lock washers
- Output gasket
- 5/16-18 x 1 hex head cap screw
- 5/16-18 lock washers
- Dead input cap
- Input gasket
- Mounting base
- Output shaft
- Bearing assembly

- 56097-K
- 56097-L
- 56097-M
- 56097-N
- 56097-O
- 56097-P
- 56097-Q
- 56097-R
- 56097-S

- Live input cap
- Seal
- Input worm 60 Hz.
- Input worm 50 Hz.
- Housing
- Freeze plug
- Bearing assembly (14276/14125A)
- Worm gear - 60 Hz.
- Worm gear - 50 Hz.
- Key 1/4 x 1/4 x 2
- Seal

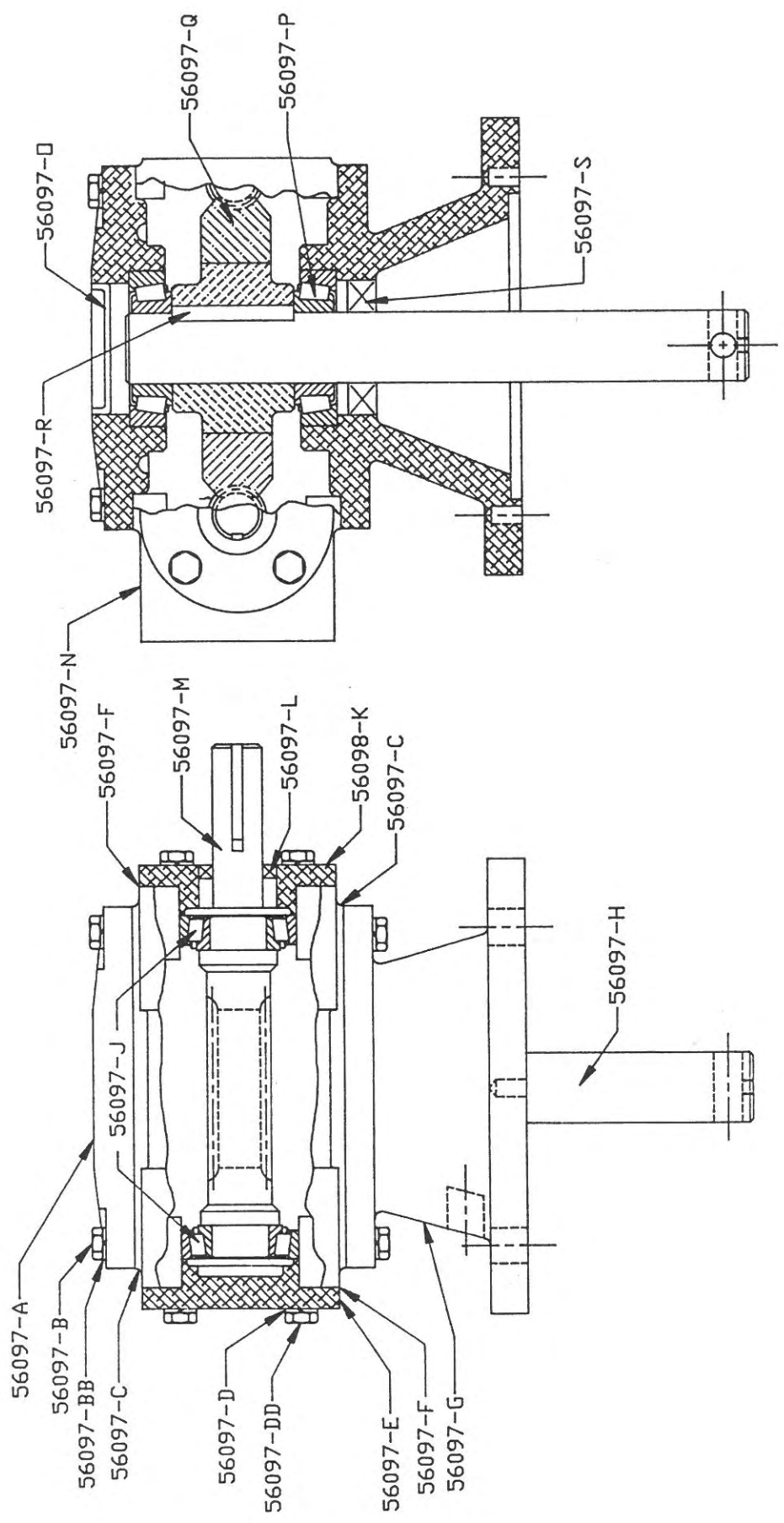

- 56095-A
- 56095-AA
- 56095-B
- 56095-C
- 56095-D
- 56095-E
- 56095-EE
- 56095-F
- 56096-F
- 56095-G
- 56095-H
- 56095-J
- 56095-K

- 3/8-16 x 1/4 hex head cap screws
- 3/8-16 lock washer
- Output cap
- Freeze plug
- Motor flange
- 5/16-18 x 1 hex head cap screw
- 5/16-18 lock washer
- Input worm - 60 Hz
- Input worm - 50 Hz
- Mounting base flange
- Output shaft
- Gasket kit complete
- Bearing assembly (14276/14125A)

- 56095-L
- 56096-L
- 56095-M
- 56095-N
- 56095-O
- 56095-P
- 56095-Q
- 56095-R
- 56095-S
- 56095-T
- 56095-U
- 56095-V
- 56095-W

- Worm gear 60 Hz.
- Worm gear 50 Hz
- Key - 1/4 x 1/4 x 2
- Housing
- Gaskets
- Seals
- Gasket
- Seal
- Bearing
- Snap ring
- Input cap
- Snap ring
- Output seal/journal box

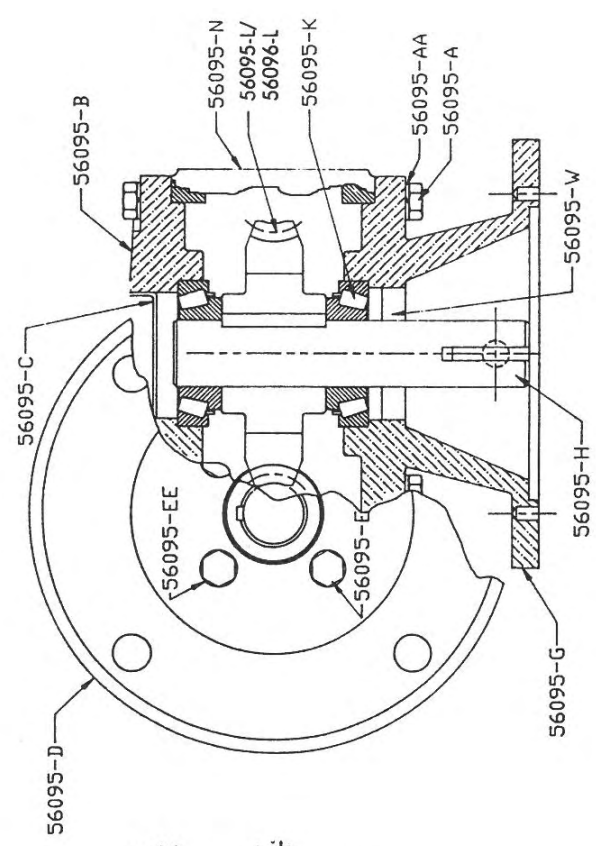
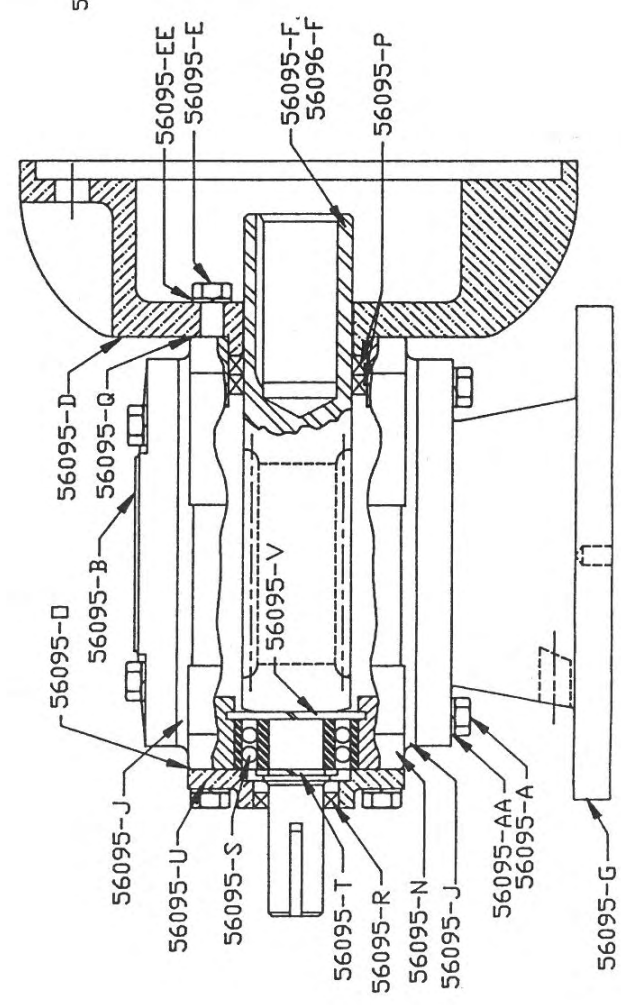

POWER CONTROLS

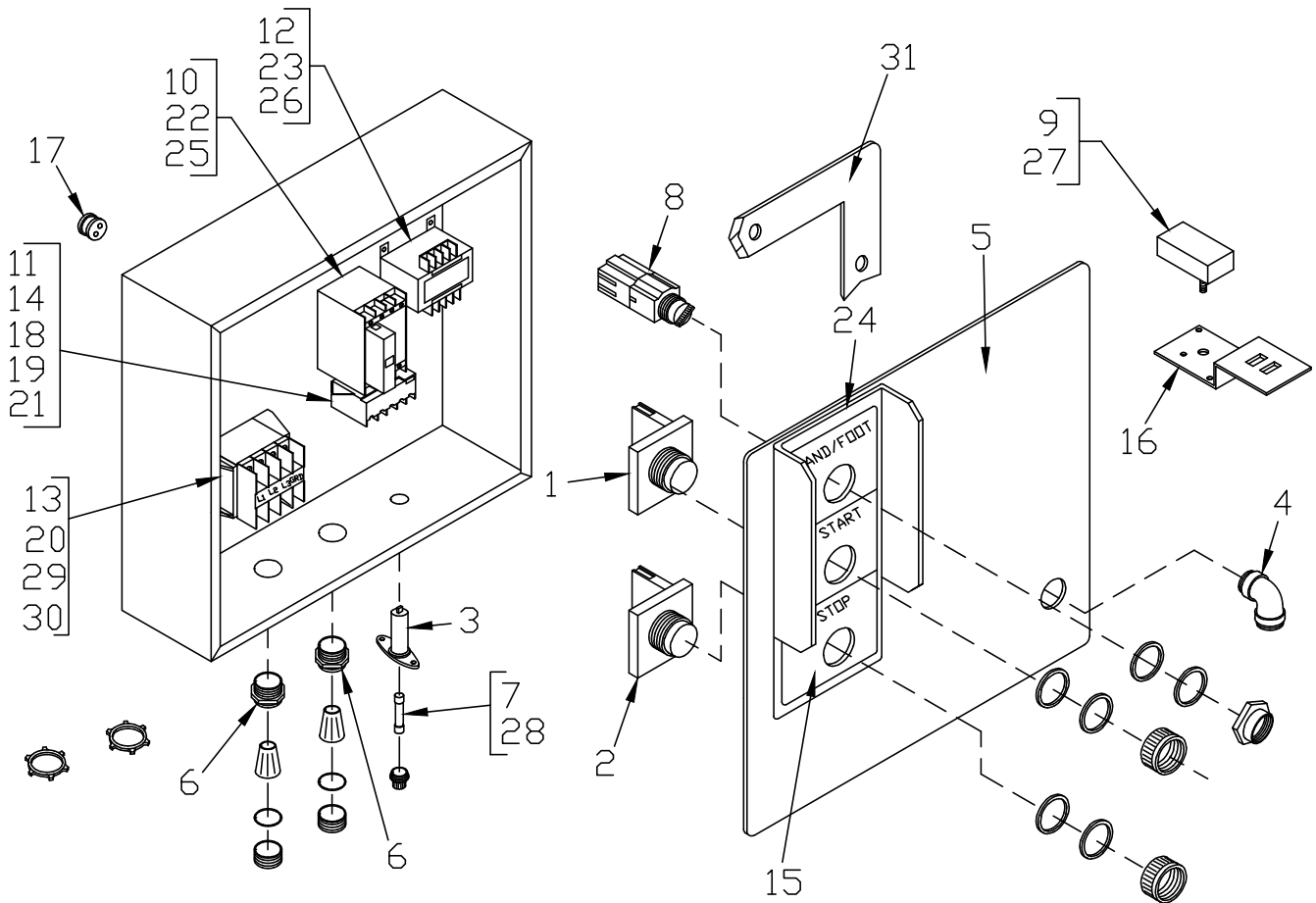

Fig.	Item No.	Description	Fig.	Item No.	Description
1	42MC-Y73	Start button, Green	18	H281EE-52	Overload, B18K-L 5.5-8.5Amps 5HP, 3Ph 460-575V, 60Hz
2	42MC-Y74	Stop button, Red	19	H281EE-53	Overload, B18K-M 8-12Amps 7½HP, 3Ph 460-575V, 60Hz
3	51991	Fuse holder	20	35375	End barrier, Terminal block
4	56301G	Watertight 90° cord connector	21	H281EE-321	Overload, B18K-ON 21-16Amps 5HP, 1Ph, 208-230V, 60Hz; 7½HP, 3Ph 208-230V, 60Hz
5	56155	Cover control panel	22	226EE-AO11K	Contactors, LS11K.11S-AO 5HP, 3Ph 208-230/460V, 60Hz 5HP, 3Ph 575V, 60Hz; 7½HP, 3Ph 220 /380-415V, 50Hz
6	53689	Cable connector assembly (2 req'd)	23	56261	Transformer, 575V/115V
7	53851	Fuse, 1 amp, 250V	24	56337	Shroud, selector switch
8	56105	Switch, selector, hand/foot	25	56339	24V Contactor, 7½HP, 3Ph 380-415V, 50Hz
9	42MC-Y64	Magnetic safety interlock switch 240V	26	BES16257	Transformer, 380/24V
10	226EE-AO15K	Contactors, LS15K.11S-AO 5HP, 1Ph, 208-230V, 60Hz; 7½HP, 3Ph 208-230/460V, 60Hz	27	55053	Magnetic safety interlock switch 250-600V (24 volt system)
11	H281EE-31	Overload, B18K-N 10-16Amps 5HP, 3Ph, 208-230V, 60Hz; 7½HP, 3Ph 380-415V, 50Hz	28	BES16259	3Amp fuse for 24 volt system
12	56110	Transformer, 230/460V Pri, 120V Sec	29	35241	Mount rail, terminal block
13	35374	Terminal block (4 req'd)	30	35376	End anchor, terminal block
14	226EE-OL18O	Overload, B18K-O 14.5-18Amps 7½HP, 3Ph 220V, 50Hz	31	56164	Control box seal
15	56125	Legend plate (controls)			
16	42MC-Y70	Safety switch bracket			
17	35067	Grommet, wire to safety switch			

RETROFIT FOR AEG CONTACTORS IN AFMG-24 CONTROL BOX SERIAL NO. 20001 ON

The magnetic contactors and overloads in the AFMG-24 have been changed to AEG electrical components. These controls are interchangeable with the old controls with some minor modifications. Use the following kit numbers when replacing previous contactors with AEG.

Kit Includes: Contactor, Subplate, and Fasteners.

Tool Req.: Screwdriver

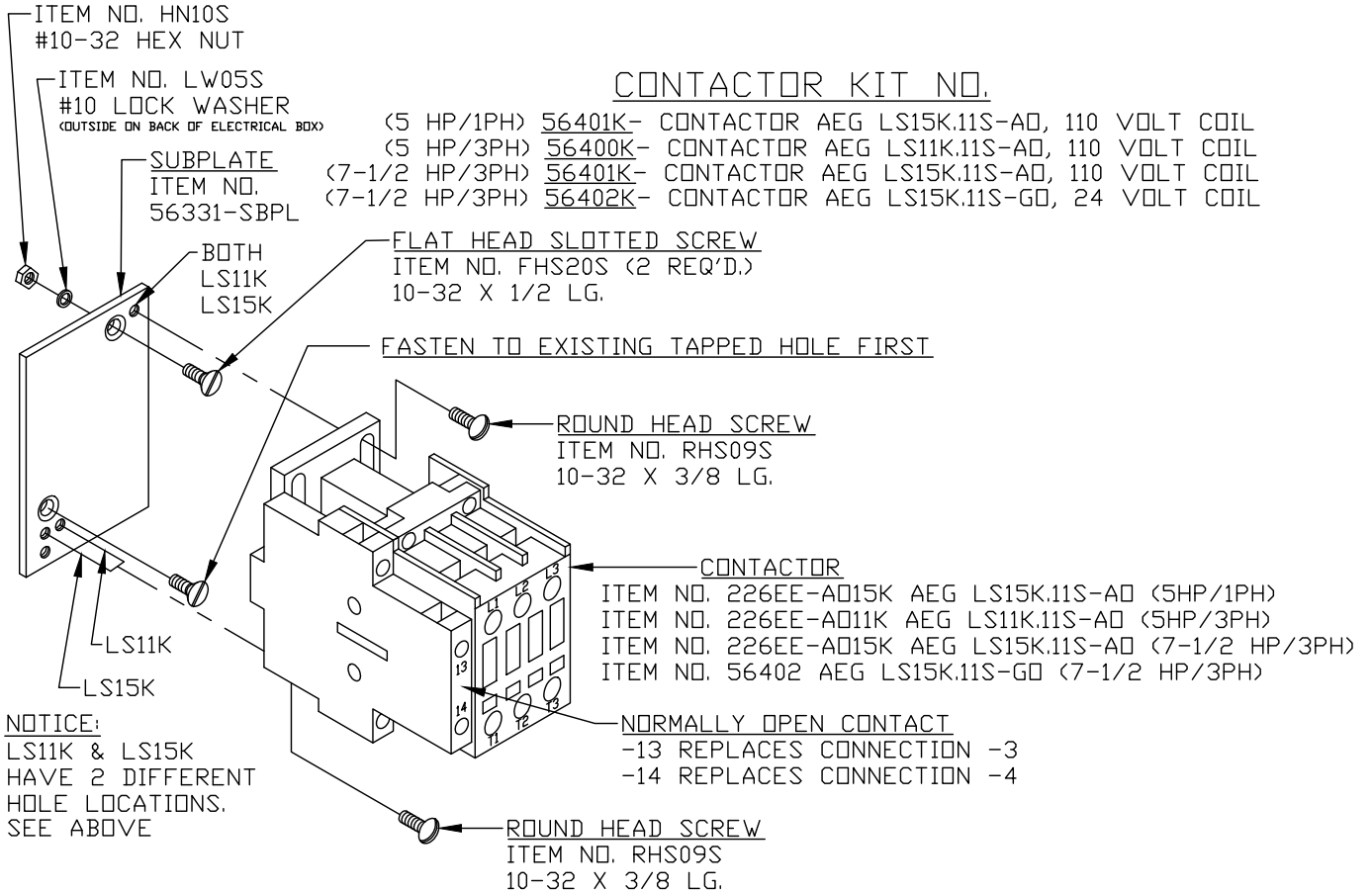

OPTIONAL STAINLESS STEEL BOWLS, AUGERS & PINS

UNGER SYSTEM FOR MODEL AFMG-24

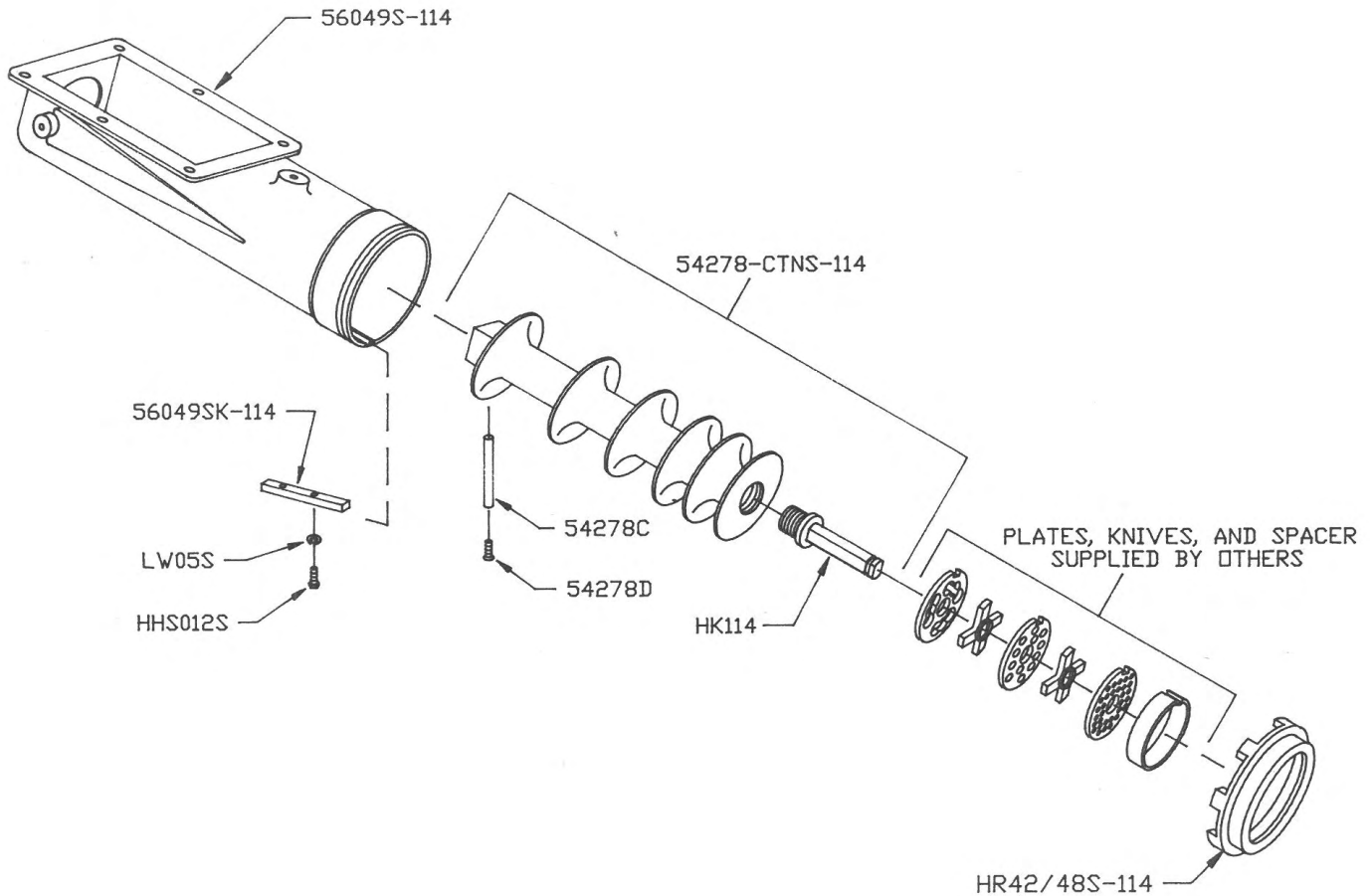

114mm UNGER SYSTEM (Shown Above)

Item No.	Description
HHS012S	Hex head screw, 10-32 x 1/2, SS
HK114	Knife drive pin, 114mm Unger
HR42/48S-114	End ring, SS, 114 Unger
54278C	Auger shear pin
FHS33S	Shear pin fastener
54278-CTNS-114	Auger assembly, SS, 114mm Unger
56049SK-114	Key, 114mm Unger
56049S-114	Bowl, SS, 114mm Unger

ENTERPRISE SYSTEM (NOT Shown)

Item No.	Description
HR42/48S	End ring, SS
54278-CTNS	Auger assembly, SS
56049S	Bowl w/ plate pins, SS

NOTE:

THE UNGER SYSTEM IS UNCOMMON, IT UTILIZES MULTIPLE KNIVES & PLATES AT A TIME. WHEREAS A STANDARD SYSTEM USES ONE OF EACH. PROVIDE SERIAL NUMBER WHEN ORDERING.

ITEMS REQUIRED FOR TANDEM OPERATION

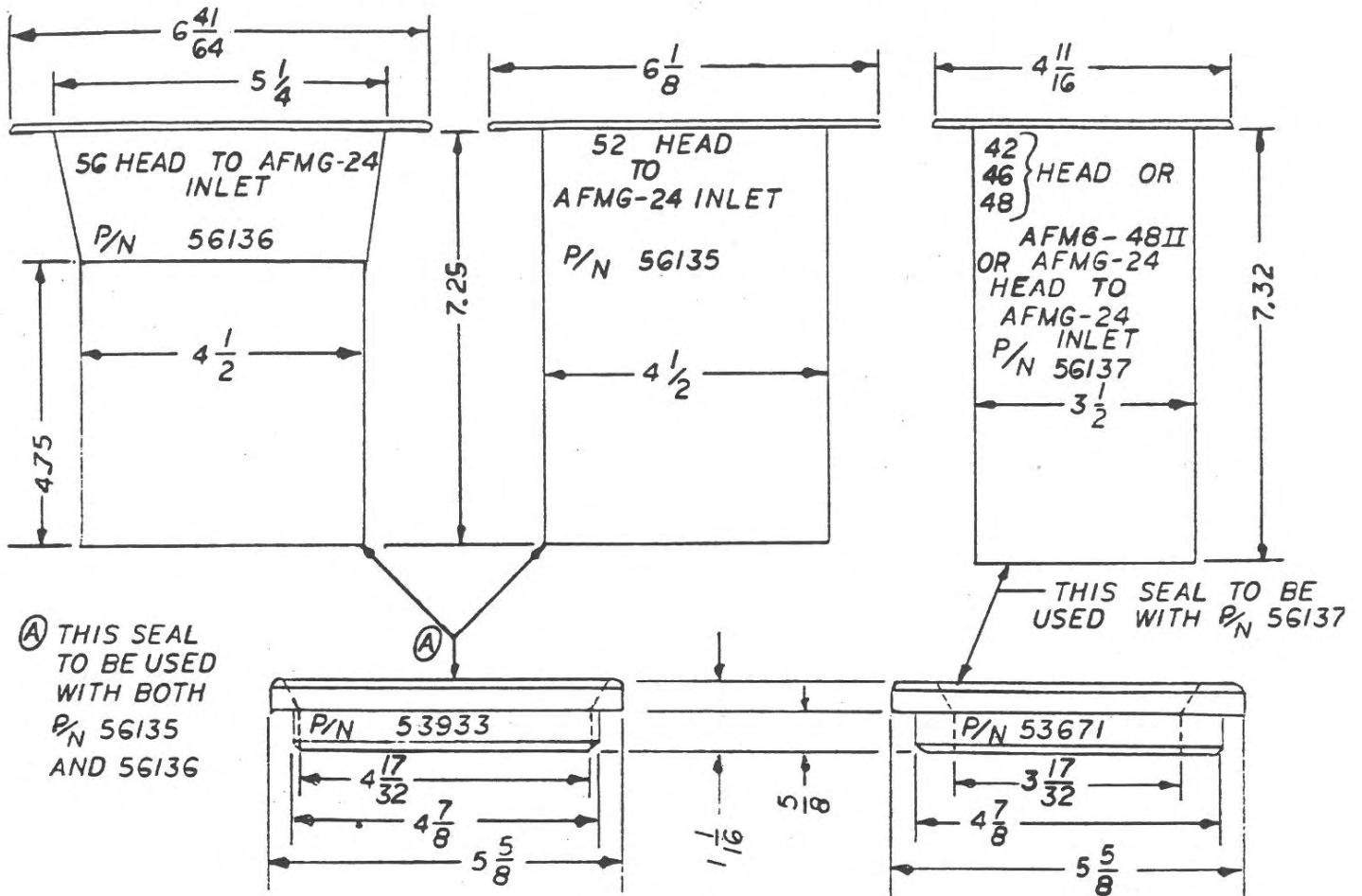

NOTE: THESE ARE DESIGNED TO WORK ON BIRO EQUIPMENT OR OTHER MANUAL AND AUTO FEED GRINDERS OF COMPARABLE PLATE SIZE

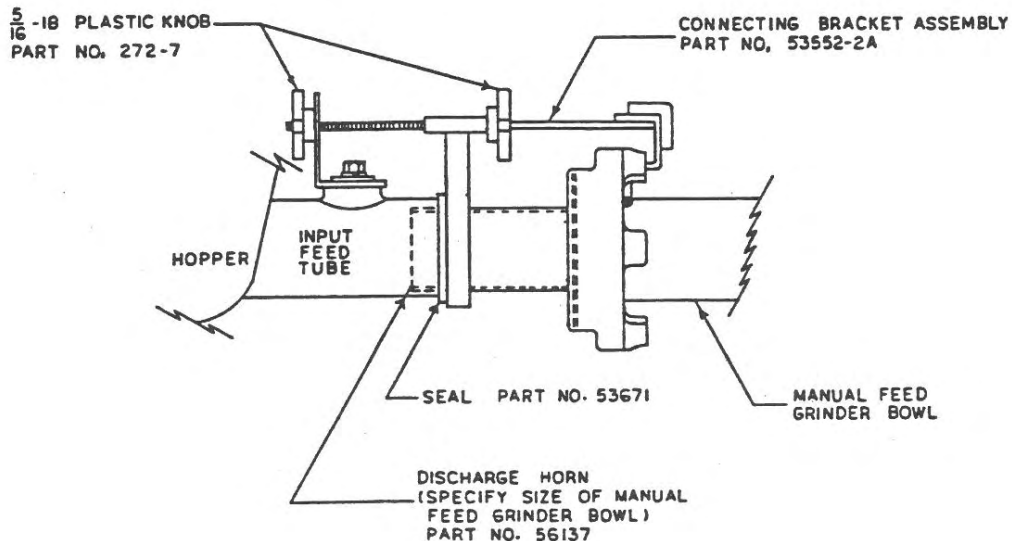

OPTIONAL PNEUMATIC FOOT SWITCH #56304

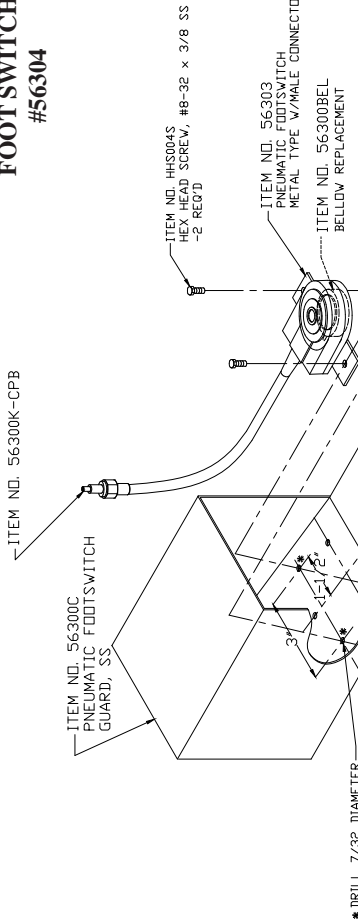

Part No.	DESCRIPTIONS
56300BEL	Bellow, Replacement
56300C	Guard Only
56300K-CPB	CPB Coupling Metal Body-Male
56303	Foot Switch w/Male Coupling
56304	Foot Switch Assembly Complete
HHS004S	Hex Head Screw, #8 - 32 x 3/4
HN05S	Hex Nut #8 - 32
LW03S	Lock Washer #8

ITEM NO.	PART NO.	PART NAME/DESCRIPTION	QTY
1	56301D	AIR SWITCH W/NUT	1
2	56301E	AIR SWITCH BRACKET	1
3	RHS05S	ROUND HEAD SCREW, #8-32 x 1/4 LG	2
4	HNS05S	HEX NUT, #8-32	2
5	56301G	WATER TIGHT 90° CORD CONNECTOR	1
6	56300H	CORD CONNECTOR LOCKNUT	1
7	56300J-CPB	COUPLING METAL BODY, FEMALE	1
8	56300K-CPB	COUPLING METAL BODY, MALE	1
9	56304	FOOT SWITCH ASSY W/6-TUBE,CPLG&GUARD	1
10	LW03S	LOCK WASHER, #8	2
11	56303	FOOT SWITCH W/MALE COUPLING	1
12	56302I	PLASTIC TUBING, 1/8 I.D. x 1/4 O.D.	12"
13	56300C	GUARD, ONLY	1
14	56300BEL	BELLOW, REPLACEMENT	1

PNEUMATIC FOOT SWITCH

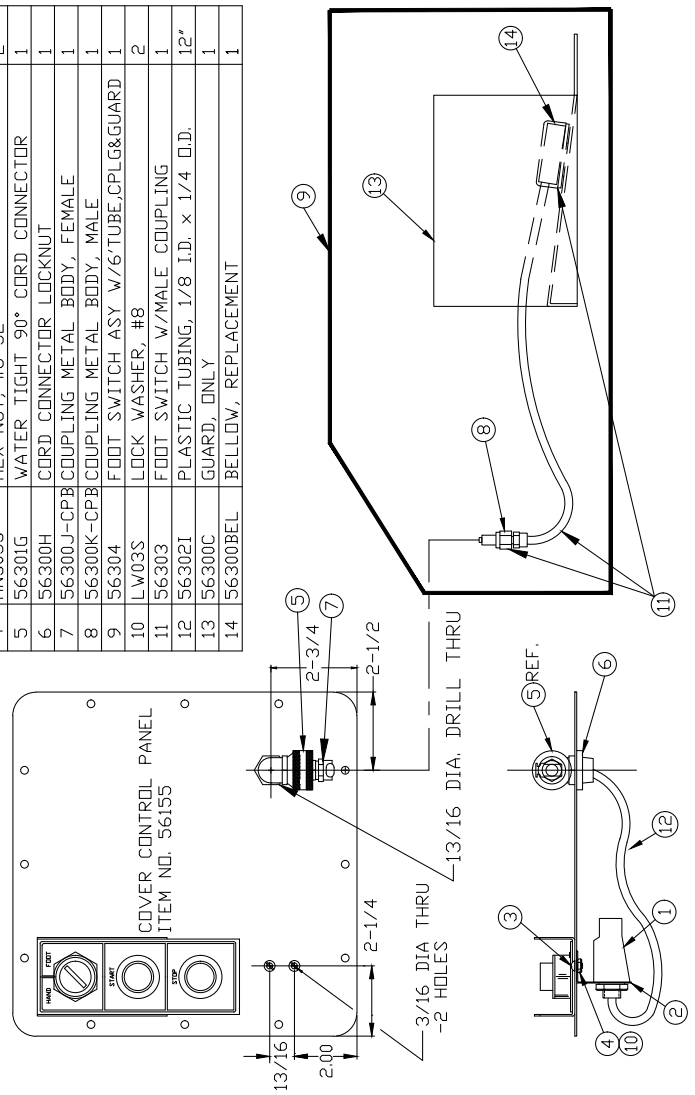

OPTIONAL ELECTRICAL FOOT SWITCH

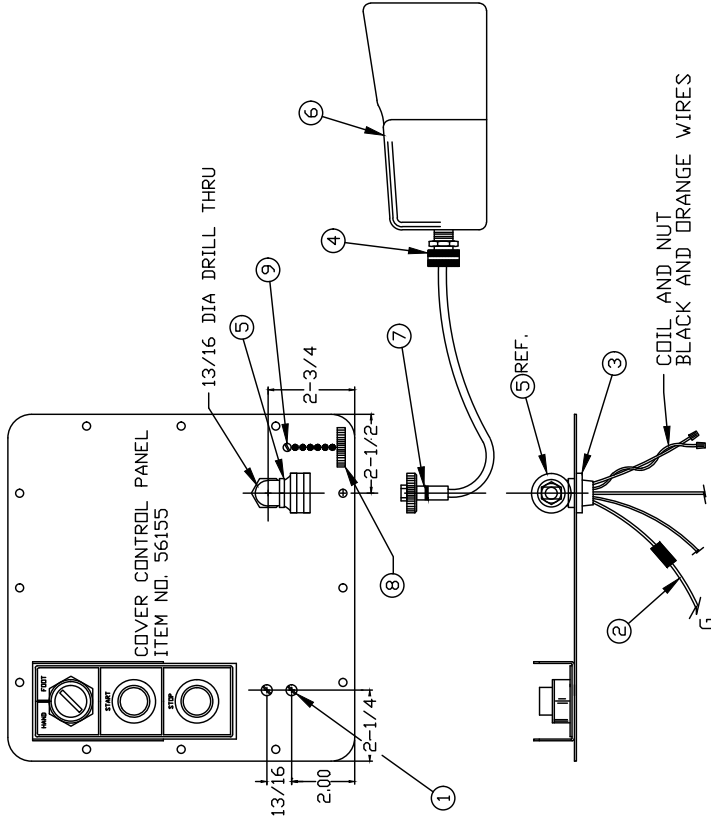

ITEM NO.	PART NO.	PART NAME/DESCRIPTION	QTY
1	1056	#8-32 x 1/2 LG. ROUND HEAD CAP SCREW	2
2		GREEN 16 GA. WIRE 8' LONG	1
3	56300H	LOCK NUT	1
4	224-2	WATER TIGHT STRAIGHT CORD CONNECTOR	1
5	56292	FEMALE RECEPTACLE, 5 POLE, 90°	1
6	54213	FOOT SWITCH ASSY W/ 6' CORD & PLUG	1
7	52654	MALE PLUG W/ 6' CORD, 5 WIRE	1
8	52662	PROTECTIVE CAP ASSEMBLY	1
9	H573	#6-32 x 3/8 LG. ROUND HEAD CAP SCREW	1

FOOTSWITCH WIRING DIAGRAM

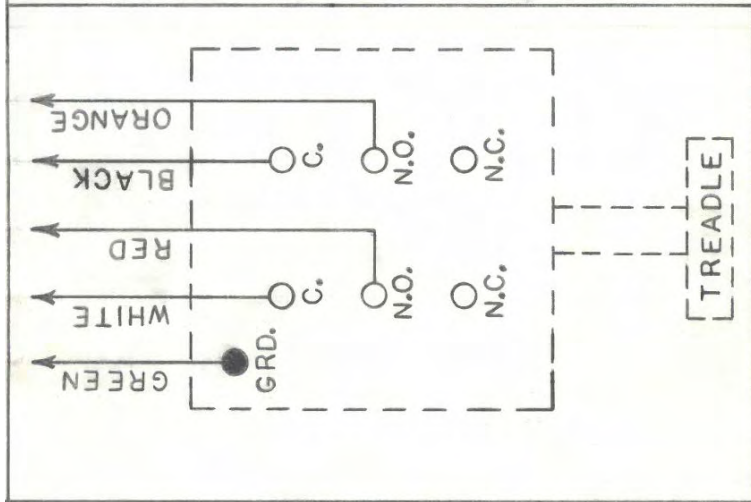

FOOT SWITCH ADJUSTMENT

To change adjustment of the operating point of an interior switch, depress the treadle to the point where you want the switch to operate. With the treadle depressed to the desired operating point, turn the adjusting screw until the switch snaps. Turn clockwise to lower the operating point and counter clockwise to raise it.

FOOT SWITCH WITHOUT COVER

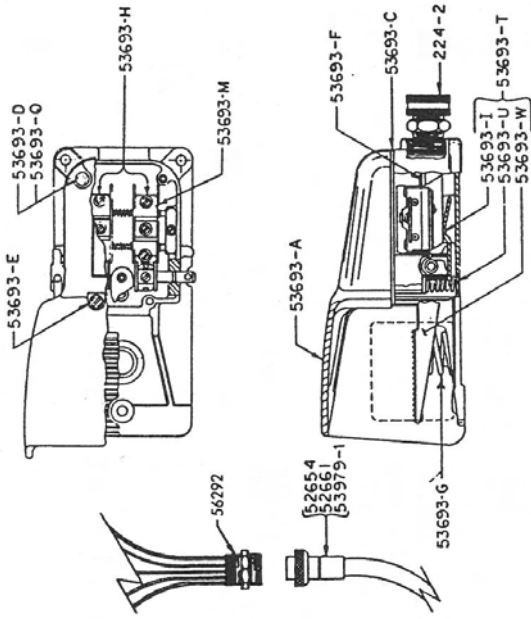
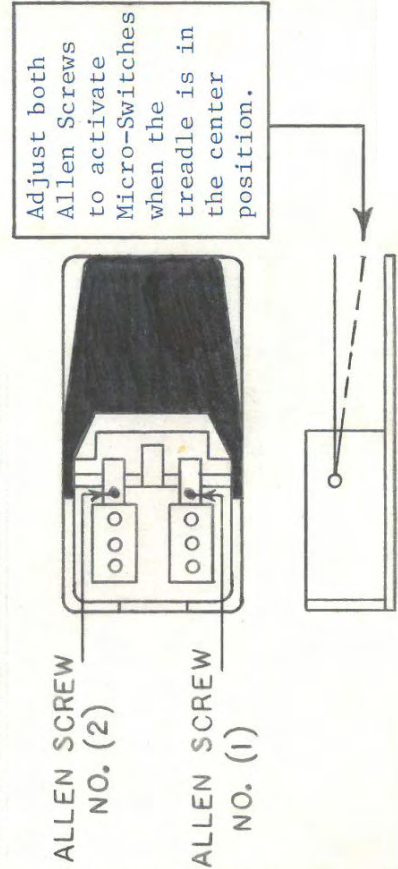

FOOTSWITCH PARTS LIST

- 224-2 Cord connector, wt, straight, 3/4"
- 52654 Male plug w/ 6' cord, 5 wire
- 52622 Female receptacle 90°
- 52661 Male plug w/ 12' cord, 5 wire
- 52668 Footswitch w/ 12' cord and plug
- 53693 Footswitch
- 53693-A Cover guard
- 53693-C Cover gasket
- 53693-D Cover screw- short
- 53693-E Cover screw- long
- 53693-F Ground screw
- 53693-G Treadle spring
- 53693-H Internal assembly complete
- 53693-I Actuator
- 53693-M Micro switch BA-2R62-A4
- 53693-O Washer
- 53693-T Treadle w/ actuator & return spring
- 53693-U Auxiliary treadle return spring
- 53693-W Treadle
- 53693-X One actuator & actuator spring assembly
- 53979-1 Cord 8' w/o footswitch
- 54213 Footswitch w/6' cord & plug

OPTIONAL

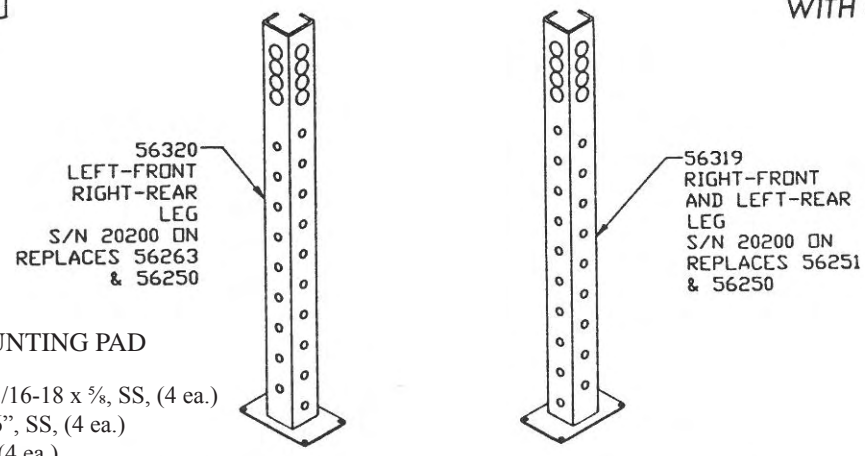
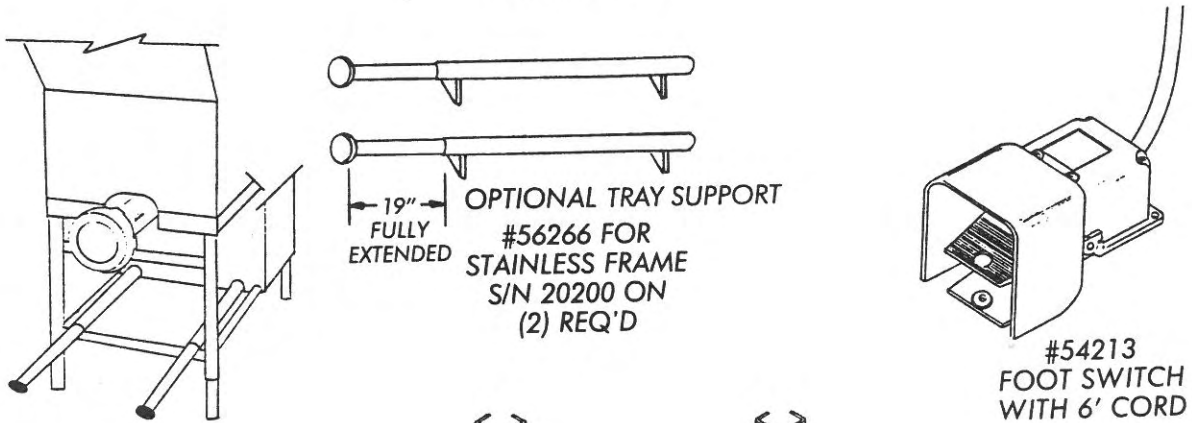
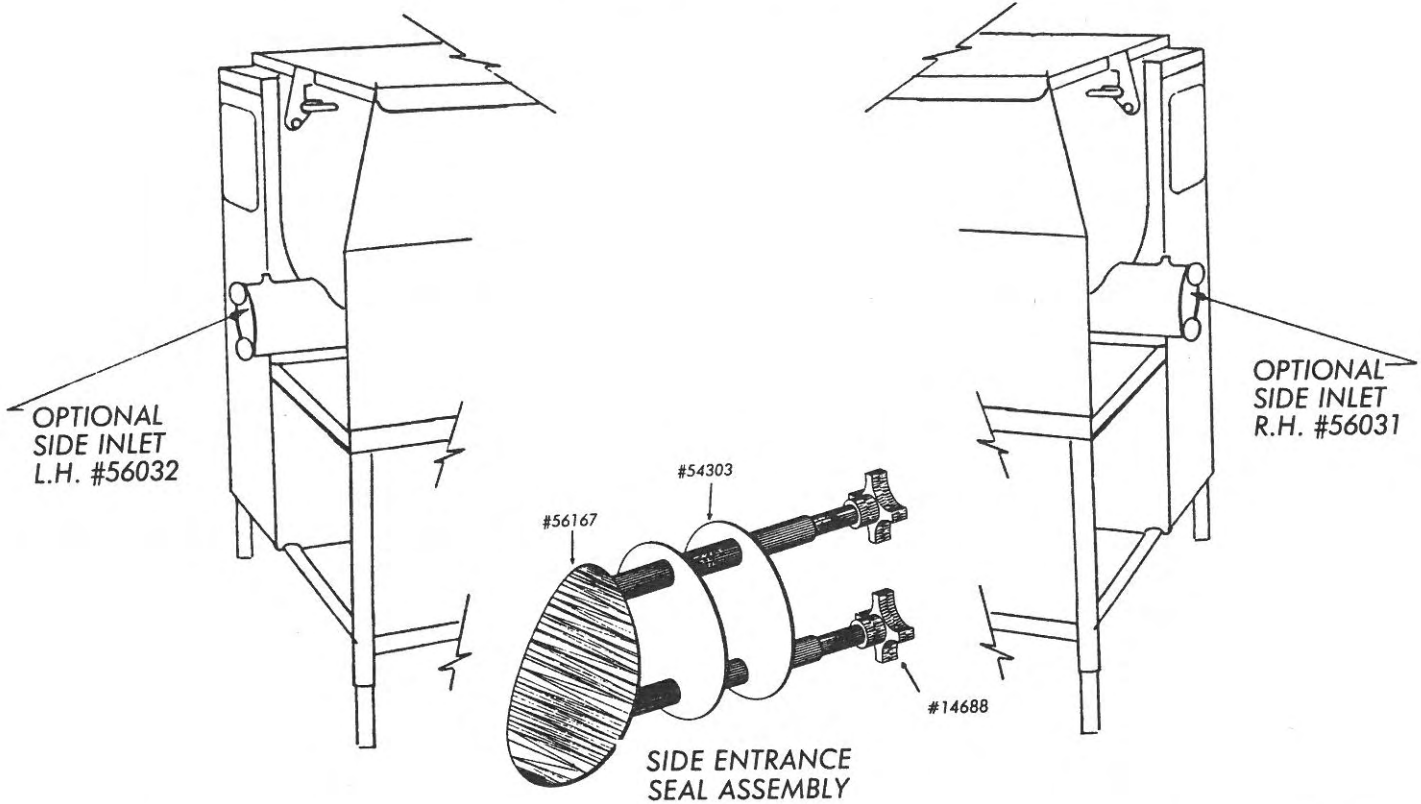

FASTENERS

CASTERS TO CASTER MOUNTING PAD

Item No.
HHS050S
LW15S
272-8

Hex head screw, 5/16-18 x 3/4, SS, (4 ea.)
 Lock washer, 5/16", SS, (4 ea.)
 Cap nut, 5/16-18, (4 ea.)



56139 RIGID CASTER REAR



56113 SWIVEL CASTER FRONT

SAFETY LABEL LOCATIONS

#H653-E

AWARNING

NEVER Touch this Grinder Unless Trained And Authorized By Supervisor and Over 18 Years Old. READ Operation Manual Thoroughly Before Operating. NEVER Place Hands Into Grinder Input or Output Opening. ALWAYS Use Stomper To Feed Product Into Manual Feed Grinder's Input Opening. NEVER Alter this Machine from its Original Form as Shipped from the Factory. NEVER Leave Grinder Unattended While Operating. ALWAYS Disconnect and Unplug from Main Power Source and Perform LOCKOUT/TAGOUT BEFORE Attempting To Unjam, Unclog, Clean or Service. #H653-E

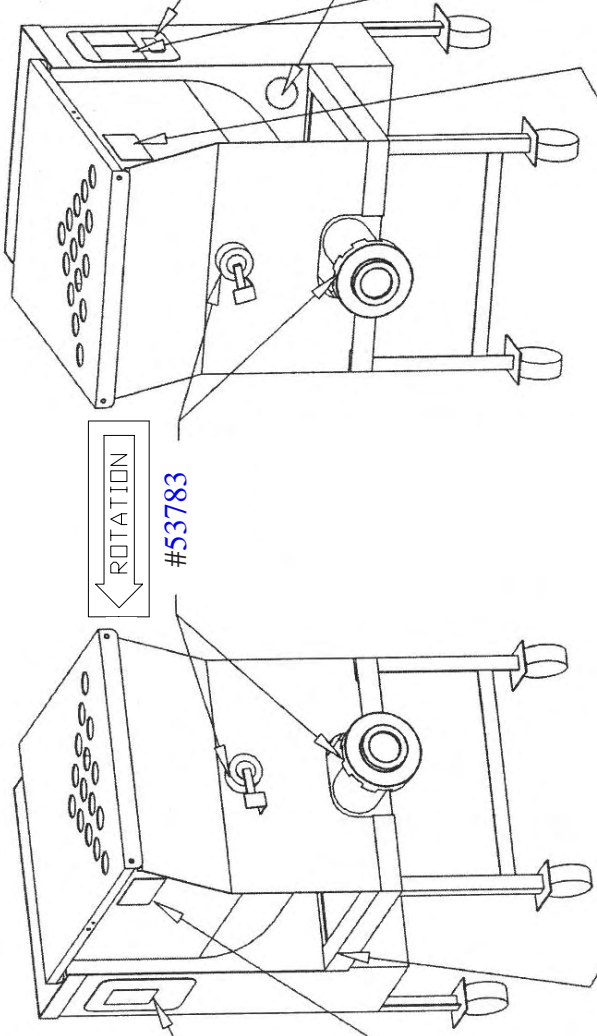

#56315

CAUTION

RISK OF ELECTRICAL SHOCK. DISCONNECT FROM POWER SOURCE BEFORE CHANGING FUSE OR OTHER SERVICING. REPLACE WITH FUSE RATED 1A, 250V.

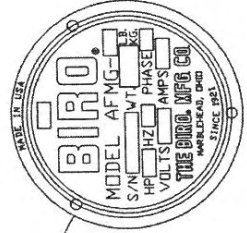

#52999-3

SERIAL NO. STAMP LOCATION

CAUTION

DO NOT FILL HOPPER ABOVE THIS LINE

53687

#53687

MUCHO CUIDADO

NUNCA Toque esta Picadora Sin Haber Tenido Entrenamiento para ello ni sin Autorización del Supervisor. Además se debe Tener 18 Años de Edad. LEA Cuidadosamente el Manual de Instrucciones antes de Querer Operar la Máquina. NUNCA Meta las Manos Dentro de la Picadora. SIEMPRE Use el Stomper para Meter el Producto Dentro de la Apertura de Entrada de la Picadora. SIEMPRE Siga las Instrucciones de la Maquina. NO Altere JAMAS la Forma que Presenta la Máquina al Salir Embarcada de la Fabrica. NUNCA Deje sola la Picadora Estando esta en Marcha. SIEMPRE Desconecte el Equipo Desenchufándolo de la Fuente de Fuerza. Déjelo Bajo Llave con ETIQUETA que Ponga su uso antes de Desconectarlo. Siempre Realice los Trabajos de Mantenimiento. Realizar Trabajos de Mantenimiento. #H653-SP

#H653-SP

AWARNING

NEVER Touch this Grinder Unless Trained And Authorized By Supervisor and Over 18 Years Old. READ Operation Manual Thoroughly Before Operating. NEVER Place Hands Into Grinder Input or Output Opening. ALWAYS Use Stomper To Feed Product Into Manual Feed Grinder's Input Opening. NEVER Alter this Machine from its Original Form as Shipped from the Factory. NEVER Leave Grinder Unattended While Operating and Unplug from Main Power Source and Perform LOCKOUT/TAGOUT BEFORE Attempting To Unjam, Unclog, Clean or Service. #H653-E

#H653-E

TANDEM OPERATION ILLUSTRATION FOR 90° INLET

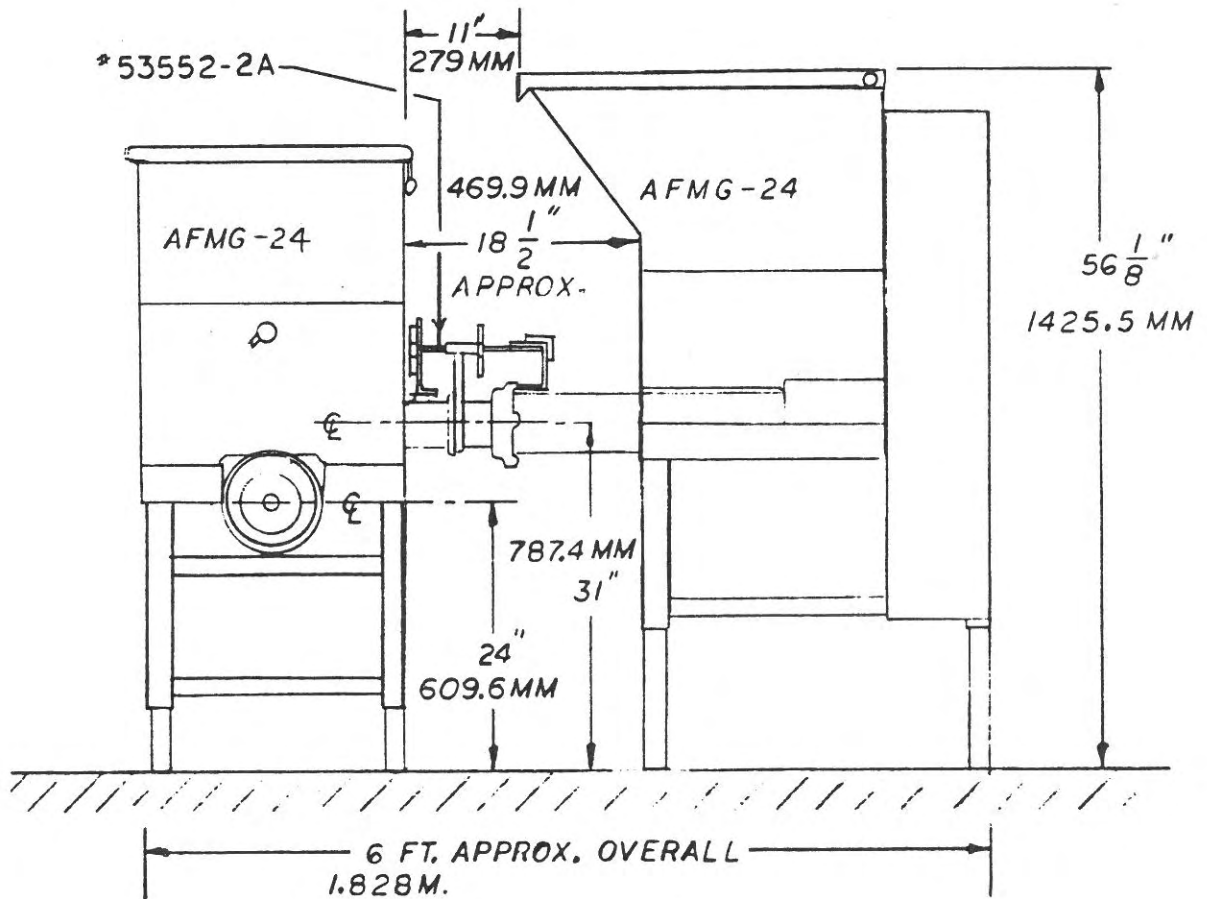
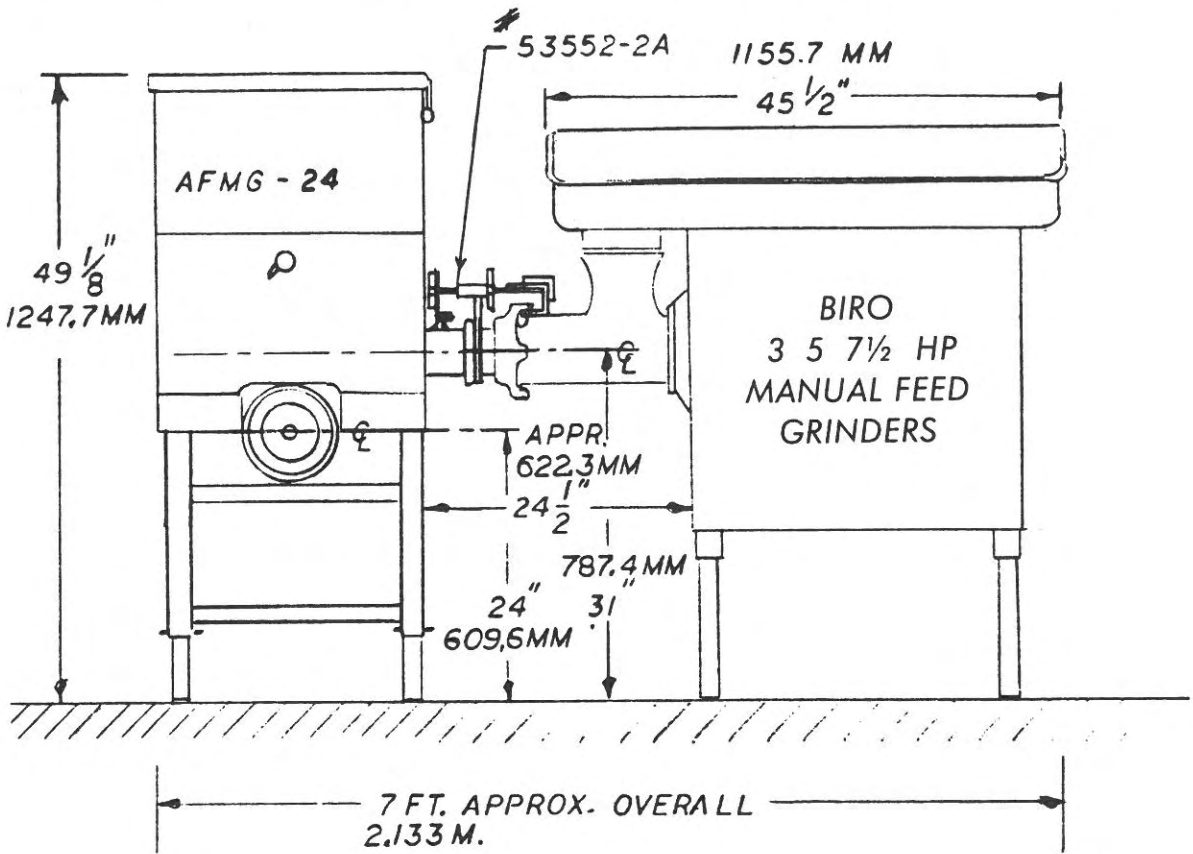

CONNECTION INSTRUCTIONS
TANDEM OPERATIONS
BIRO AFMG-24 into BIRO AFMG-24
BIRO Heavy Horsepower Grinder into BIRO AFMG-24

- Step 1.** Remove Side Entrance Seal, Item No. 56167; Outer Disc, Item No. 54303 and Lock Knobs, Item No. 14688 from the inlet tube of the Second Grind Machine. Clean out the tube if necessary.

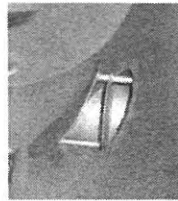
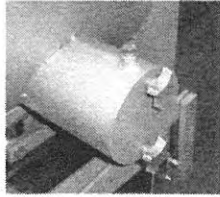

- Step 2.** Install the Inlet Tube Seal Item No. 53671 or 53933 into the inlet tube of the Second Grind Machine until fully seated. Bolt the supplied connecting angle to the inlet tube.



- Step 3.** Remove the Ring from the First Grind Machine, Item No. HR42/48, HR52 or HR56. Insert the Item No. 56137, 56135 or 56136 Discharge Horn into the Ring. Reinstall the ring on the machine.

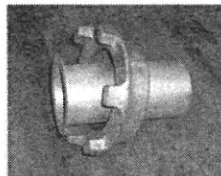

- Step 4.** Insert the Discharge Horn into the inlet tube.

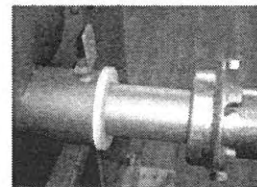

- Step 5.** With the seal clamp in place. Install the Connecting Bracket over the first grinders ring, slide the connecting bracket rod into the connecting angle. Install the lock knob and tighten. Tighten the seal bracket lock knob to tighten against the seal.

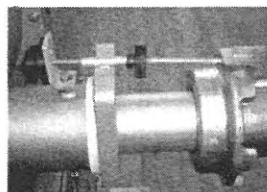
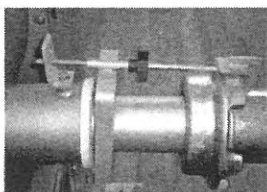

- OPERATOR'S NOTES -

LIMITED WARRANTY

WARRANTY: The BIRO Manufacturing Company warrants that the BIRO AFMG-24 Grinder will be free from defects in material and workmanship under normal use and with recommended service. BIRO will replace defective parts, which are covered by this limited warranty, provided that the defective parts are authorized for return, shipping charges prepaid, to a designated factory for inspection and/or testing.

DURATION OF WARRANTY: The warranty period for all parts covered by this limited warranty is one (1) year from date of Inspection/Demonstration as advised on the returned Warranty Registration card, or eighteen (18) months from original factory shipping date, whichever date occurs first, except as noted below.

PARTS NOT COVERED BY WARRANTY: The following are **not** covered by this limited warranty: wearable parts in the grinding system such as the bowl, bowl pin, ring, worm, drive shaft, knife drive pin, plate and knife. This limited warranty does not apply to machines sold as used, rebuilt, modified, or altered from the original construction in which the machine was shipped from the factory. Water contaminated electrical systems are not covered under this limited warranty. BIRO is not responsible for electrical connection of equipment, adjustments to switch components or any other electrical requirements, which must be performed only by a certified electrician. BIRO is not responsible for service charges or labor required to replace any part covered by this limited warranty or for any damages resulting from misuse, abuse, lack of proper or recommended service.

EXCLUSION OF WARRANTIES AND LIMITATION OF REMEDIES: BIRO gives no warranties other than those expressly stated in this limited warranty. THE IMPLIED WARRANTY OF MERCHANTABILITY, THE IMPLIED WARRANTY OF FITNESS FOR PROCESSING OF FOOD PRODUCTS, AND ALL OTHER IMPLIED WARRANTIES ARE SPECIFICALLY EXCLUDED. BIRO IS NOT LIABLE FOR CONSEQUENTIAL OR INCIDENTAL DAMAGES, EXPENSES OR LOSSES. THE REMEDIES PROVIDED IN THIS BIRO LIMITED WARRANTY ARE PURCHASER'S SOLE AND EXCLUSIVE REMEDIES AGAINST BIRO.

REGISTRATION CARDS: You must sign, date and complete the warranty registration card supplied with each machine. The warranty card must be returned to The Biro Manufacturing Company for proper registration. If no warranty card is returned to BIRO, the warranty period will begin from the date the machine was originally shipped from the factory.

HOW TO GET SERVICE:

1. Contact the entity from whom you purchased the machine; or
2. Consult the yellow pages of the phone directory for the nearest authorized dealer; or
3. Contact Biro Mfg. Company for the authorized service entity in your area.

BIRO MANUFACTURING COMPANY
1114 Main St.
Marblehead, OH 43440 U.S.A.
Telephone: 419-798-4451 Fax: 419-798-9106
E-mail: service@birosaw.com; <http://www.birosaw.com>