



MODEL AFMG-52-4 AUTOMATIC FEED MIXER GRINDER OPERATING AND SERVICE MANUAL



★ IMPORTANT NOTICE ★

This Manual contains important safety instructions which must be strictly followed when using this equipment.

MODEL AFMG-52-4 AUTOMATIC FEED MIXER GRINDER

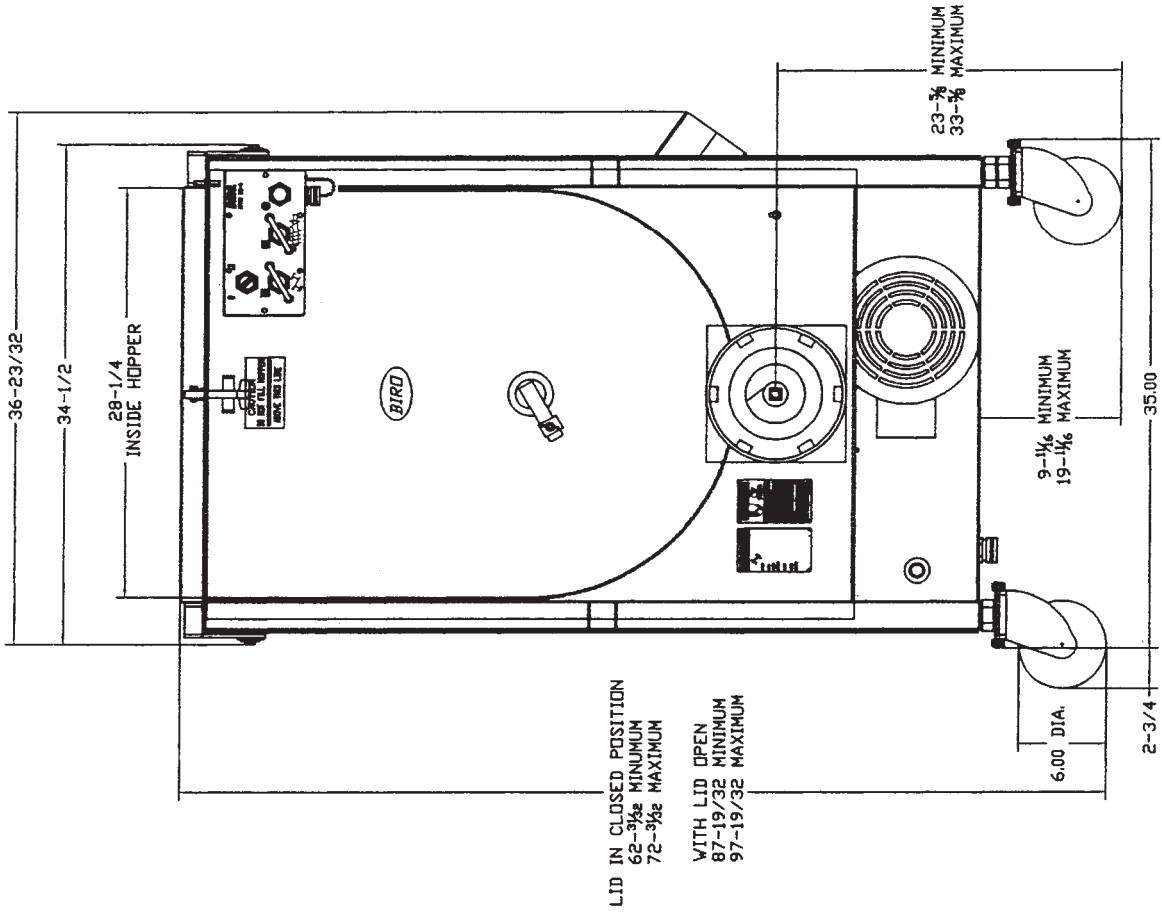
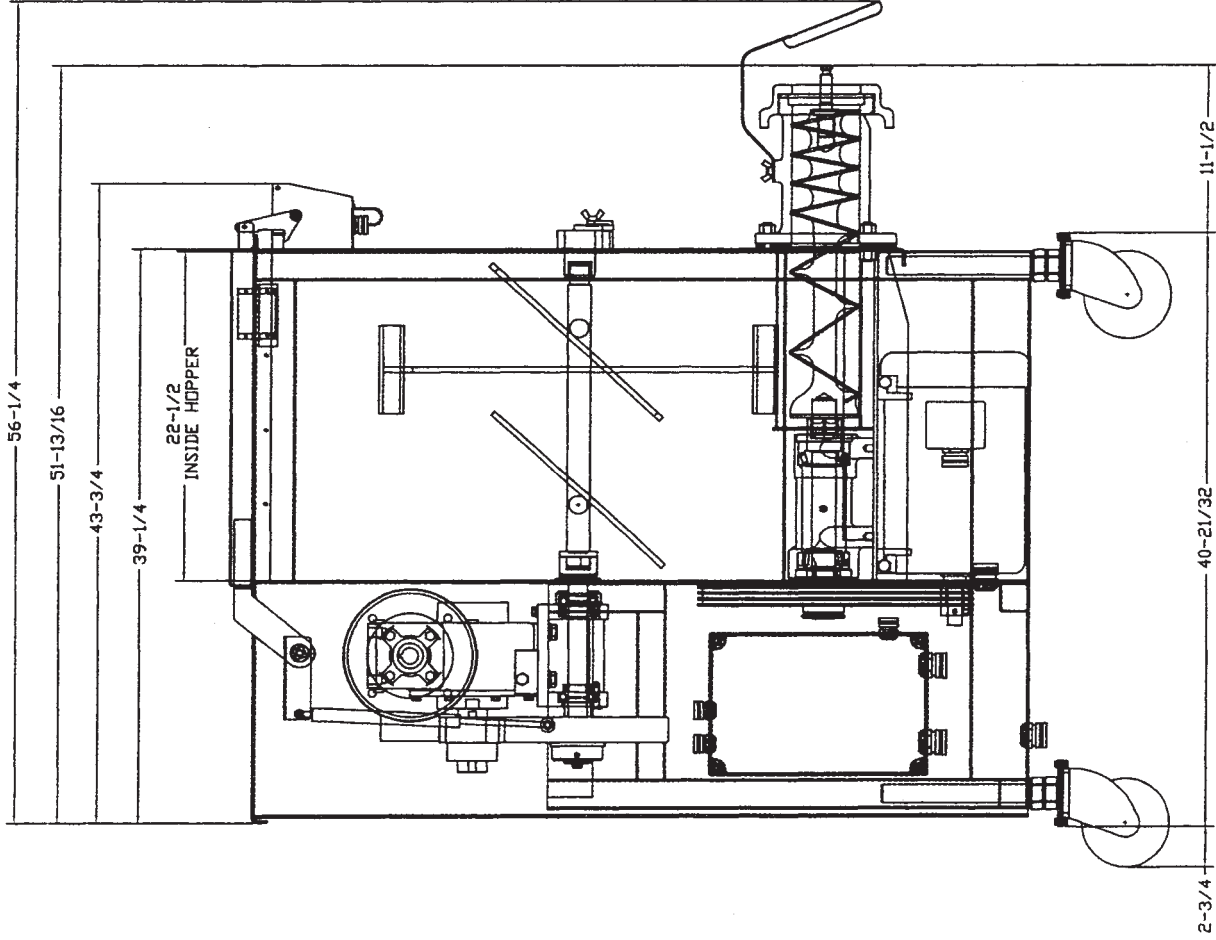

TABLE OF CONTENTS

	Page
NOTICE TO OWNERS AND OPERATORS.....	1
SAFETY TIPS	2
INSTALLATION	3
UNCRATING AND SETUP.....	3
MOTOR WIRING AND ELECTRICAL REQUIREMENTS	4
STEP ASSEMBLY	4
OPERATION.....	6
TO PROCESS PRODUCT.....	6
CLEANING.....	7
MAINTENANCE.....	8
GRINDING BOWL INSTALLATION	8
MIXING PADDLE INSTALLATION.....	8
LUBRICATION.....	8-11
WINSMITH GEAR REDUCER LUBRICATION.....	9-10
SPUR GEAR LUBRICATION	11
MIXER DRIVE GEAR ADJUSTMENT.....	11
MAIN DRIVE CHAIN AND SPROCKET LUBRICATION	11
MAIN DRIVE CHAIN ITENSION.....	12-14
CHAIN REPLACEMENT.....	12
PARTS DIAGRAMS	15 - 25
JOURNAL BOX	23
OPTIONAL STAINLESS STEEL BOWLS, AUGERS & END RINGS (130mm UNGER & ENTERPRISE).....	23
ELECTRICAL COMPONENT ASSEMBLY	25
WIRING DIAGRAMS.....	26 & 27
ELECTRIC AND PNEUMATIC FOOTSWITCH.....	28
ITEMS REQUIRED FOR TANDEM OPERATION	29
CONNECTION INSTRUCTIONS FOR TANDEM OPERATION	30 - 32
SAFETY LABEL LOCATIONS.....	33
OPERATOR'S NOTES	34 & 35
OPERATOR'S SIGNATURE PAGE.....	36
LIMITED WARRANTY	37

NOTICE TO OWNERS AND OPERATORS

BIRO's products are designed to process food products safely and efficiently. Unless the operator is properly trained and supervised, however, there is the possibility of a serious injury. It is the responsibility of the owner to assure that this machine is used properly and safely, strictly following the instructions contained in this Manual and any requirements of local law.

No one should use or service this machine without proper training and supervision. All operators should be thoroughly familiar with the procedures contained in this Manual. Even so, BIRO cannot anticipate every circumstance or environment in which its products will be used. You, the owner and operator, must remain alert to the hazards posed by the function of this equipment — particularly the ROTATING GRINDING AUGER and the ROTATING MIXING PADDLE, which can severely injure an inattentive operator amputating fingers and limbs. No one under eighteen (18) years of age should operate this equipment. If you are uncertain about a particular task, ask your supervisor.

This Manual contains a number of safe practices in the SAFETY TIPS section. Additional warnings are placed throughout the Manual. Warnings related to your personal safety are indicated by:



OR



Warnings related to possible damage to the equipment are indicated by:



BIRO also has provided warning labels on the equipment. If any warning label or Manual becomes misplaced, damaged, or illegible, please contact your nearest Distributor or BIRO directly for a replacement.

Remember, however, this Manual or the warning labels do not replace the need to be alert and to use your common sense when using this equipment.

– NOTE –

“A copy of this manual is included with each MODEL AFMG 52-4 MIXER GRINDER.”

**“The descriptions and illustrations contained in this manual are not binding.
The manufacturer reserves the right to introduce any modification
without updating the manual.”**

SAFETY TIPS

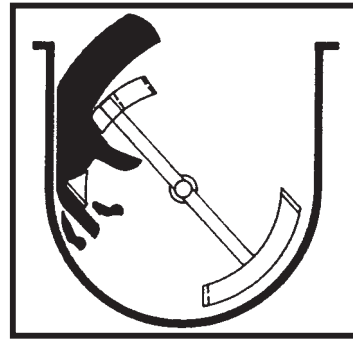

ROTATING GRINDING AUGER & ROTATING MIXING PADDLE TO AVOID SERIOUS PERSONAL INJURY

- **NEVER** Touch This Machine without Training and Authorization by Your Supervisor.
- **NEVER** Place Hands into Machine Input or Output Openings.
- **NEVER** Open Machine During Operation.
- **ONLY** Use a Qualified Electrician to Install According to Local Building Codes: Machine **MUST** Be Properly Grounded.
- **ALWAYS** Connect to **Proper** Voltage & Phase.
- **ONLY** Install on Level, Non-Skid Surface in a Clean, Well-Lighted Work Area Away from Children and Visitors.
- **ALWAYS** Lock Machine Castors After Moving This Machine.
- **NEVER** Use This Machine For Non-Food Products.
- **NEVER** Operate Machine With Product Mixer Safety Cover Open or Removed or Magnetic Interlock Switch By-Passed.
- **ALWAYS** Turn Off, Unplug Machine From Power Source and Perform Lockout/Tagout Procedure to this Machine **BEFORE** Attempting to Unjam or Unclog, Cleaning or Servicing
- **NEVER** Leave Machine Unattended While Operating.
- **NEVER** Alter This Machine From its Original Form as Shipped From Factory. **DO NOT** Operate Machine With Missing Parts.
- **PROMPTLY REPLACE** Any Worn or Illegible Warning Labels.
- **ALWAYS** Read Operation and Service Manual **BEFORE** Operating, Cleaning, or Servicing.
- **USE ONLY** BIRO Parts and Accessories Properly Installed.

INSTALLATION



TO AVOID SERIOUS PERSONAL INJURY, PROPERLY INSTALL EQUIPMENT IN ADEQUATE WORK AREA

- **ALWAYS** Use Qualified Technician and Electrician for Installation.
- **ALWAYS** Connect to **Proper** Voltage & Phase.
- **ALWAYS** Install Equipment in Work Area with Adequate Light and Space Away From Children and Visitors.
- **ONLY** Operate on a Solid, Level, Non-Skid Surface.
- **ALWAYS** Lock Machine Castors After Moving Machine to Operating Location.
- **NEVER** Bypass, Alter, or Modify This Equipment in Any Way From Its Original Condition.
- **NEVER** Operate With Product Mixer Safety Cover Opened or Removed or Magnetic Interlock Switch by-Passed.
- **NEVER** Operate Without all Warning Labels Attached and Owner/Operator Manual Available to the Operator.

UNCRATING AND SET UP

1. Read this Manual thoroughly before installation and operation. **Do not** proceed with installation and operation if you have any questions or do not understand anything in this Manual. Contact your local Distributor, or BIRO **first**.
2. Remove all banding, shipping carton, and all equipment from inside the tub. Then take machine off shipping pallet.
3. This machine is shipped with the adjustable legs fully retracted. The legs allow for a height adjustment from the floor to centerline of bowl $23\frac{5}{8}$ " minimum to $33\frac{5}{8}$ " maximum..
4. This machine weighs approximately 1,302 pounds. To avoid accidents block up machine after raising to desired operating height.
5. The adjustable legs can now be unbolted and lowered to the floor using the following steps.
 - a. Unbolt leg and turn leg adjusting nut (Item No. **60120**) counterclockwise until caster rests on floor.
 - b. Retighten lock nuts securely.
6. Install machine on a level, non-skid surface in a well-lighted work area away from children and visitors.
7. This machine is complete except for knife and plate. There is a bowl shipping plug (stamped steel) placed in the output end of the grinding bowl to retain the grinding auger during shipment. **REMOVE THE BOWL SHIPPING**



PLUG AND THE GRINDING AUGER.

8. After checking and making sure the power supply is correct, plug in your machine. **NEVER OPERATE THIS MACHINE WITH PRODUCT MIXER SAFETY COVER OPEN.** (Machine will not run with cover open.)
9. Machine must be properly grounded. Use qualified electrician to install according to local building codes.

MOTOR WIRING AND ELECTRICAL REQUIREMENTS

1. Interchange of current is made in motor outlet box. Leads are properly marked. Changing instructions are on the motor plate or motor outlet box.
2. All grinders are wired 220 volts unless otherwise specified. Be sure motor specifications (voltage, cycle, phase) match power supply line. Be sure line voltage is up to specification.
3. Electrical connections to be in accordance with safety codes and National Electrical Code.
4. Rated voltage of the unit shall be identical with full supply voltage.
5. Voltage drop on the supply line shall not exceed 10% of full supply voltage.
6. The feederline conductor size in the raceway from the branch circuit to the unit must be correct to assure adequate voltage under heavy starting and short overload conditions.
7. The feederline conductor shall only be used for the supply of one unit of the relevant horsepower. For connections of more than one unit on the same feederline, a local electrician will have to be consulted to determine the proper conductor size.
8. The size of the electrical wiring required from the power source to the mixer grinder with 10HP grind motor is a **MINIMUM OF No. 6 WIRE.**
9. The BIRO Manufacturing Company is not responsible for permanent wiring, connection or installation



NOTE TO OWNER AND ELECTRICIAN: IF THIS MACHINE IS NOT CORD AND PLUG CONNECTED TO THE ELECTRICAL SUPPLY SOURCE, THEN IT SHOULD BE EQUIPPED WITH, OR CONNECTED TO, A LOCKABLE, MANUALLY-OPERATED DISCONNECT SWITCH (OSHA 1010.147).

10. Install step assembly Part No. 43032 on grinder's frame cross brace. See diagram below.

No. 43032 STEP ASSEMBLY

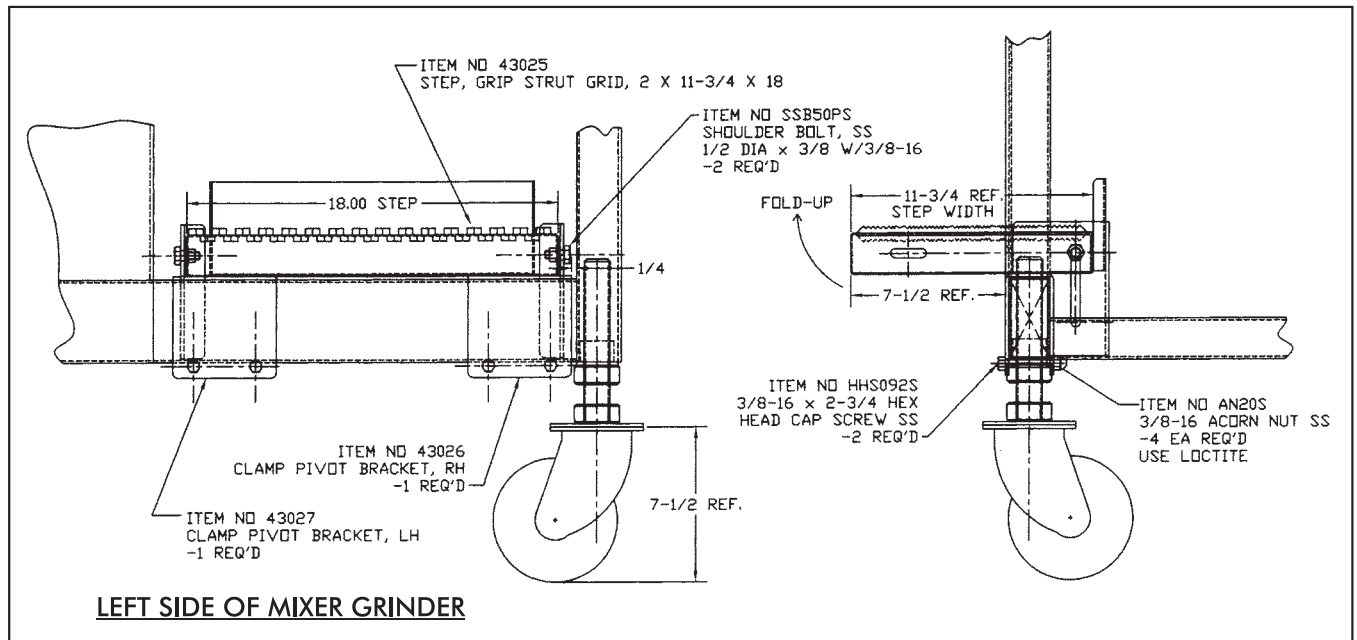

11. Two green and one red pushbuttons are located on the front of the machine that activate the magnetic contactors that control the mix and grind motors. The magnetic interlock switch is mounted behind the wireway cover located at the top-side of the hopper. It lines up with the magnet attached to the product mixer safety cover. When the safety cover is raised the machine will stop operation. Before initial power is applied for start-up, the product mixer safety cover must be lifted slightly and closed again before pushing the mixer start and/or grinder start push buttons.
12. Push the green start button for grind. **CHECK THE ROTATION OF THE AUGER DRIVE SHAFT; ROTATION MUST BE COUNTER-CLOCKWISE** as indicated by the rotation decal affixed to the grinding bowl. **ROTATION MUST ONLY BE CHECKED WITH THE GRINDING AUGER REMOVED**, otherwise serious irreparable damage may occur to grinding components. Rewire if necessary at the plug.
13. Push the green start button for mix. **CHECK ROTATION OF THE MIXING PADDLE; ROTATION MUST BE COUNTER-CLOCKWISE** as indicated by the rotation decal located on the paddle front mounting hub. Backwards operation will not allow mixing paddle to feed product to the grinding auger.



14. If machine runs clockwise (backwards), it must be rewired to correct rotation, otherwise serious irreparable damage may occur to grinding components. Both the auger and the mixing paddle must operate in the same direction.
15. Check operation of optional footswitch if equipped. Plug footswitch cord into fitting at the bottom of the pushbutton control box. Move toggle selector to foot. The machine will operate with pressure on the footswitch treadle. Releasing the treadle stops the machine. The footswitch operates the mix and grind together.
16. Insert auger assembly into grinding bowl, place knife (sharp edges out) onto the square end of the auger assembly. The breaker plate slides over the worm knife drive pin, and is held from rotating by pins in the grinding bowl. Install the retaining ring.



ONLY HAND TIGHTEN RETAINING RING

For best results, use knife and plate as a set. **Do not operate machine for any period of time** without product in the grinding bowl. This will cause heating and dulling of the knife and plate.

17. Check placement of all warning labels and Manual. Machine is now ready for trained operators to process product.
18. Use meat deflector attached to grinding bowl to eliminate meat splatter.
19. Contact your local Distributor or BIRO directly if you have any questions or problems with the installation or operation of this machine.

OPERATION



ROTATING GRINDING AUGER & ROTATING MIXING PADDLE TO AVOID SERIOUS PERSONAL INJURY

- **ONLY** Properly Trained Personnel Should Use This Equipment.
- **NEVER** Place Hands Into Machine Input or Output Openings.
- **NEVER** Open Machine During Operation.
- **DO NOT** Wear Gloves While Operating.
- **DO NOT** Tamper With, Bypass, Alter, or Modify This Equipment in Any Way From Its Original Condition.
- **NEVER** Operate Machine With Product Mixer Safety Cover Opened or Removed or Magnetic Interlock Switch By-Passed.
- **ALWAYS** Turn Off and Unplug Machine from Power Source and Perform Lockout/Tagout Procedure to This Machine Before Unjamming, Unclogging, Cleaning or Servicing.
- **NEVER** Leave Unattended While Operating.
- **NEVER** Operate Without All Warning Labels Attached and Owner/Operator Manual Available to the Operator.

A. TO PROCESS PRODUCT

1. Before starting mixer grinder, have a container for receiving ground product at the output end of the grinding bowl.
2. **FIRST GRIND**
 - a. Fill Product Hopper (Maximum 400 Pounds), close Product Mixer Safety Cover.
 - b. Push both grind and mix green start buttons to feed first grind. It is recommended to use a breaker plate with $\frac{3}{8}$ " diameter or larger holes.
 - c. Push the red stop button when all product has been ground out.
3. **SECOND GRIND**
 - a. Fill Product Hopper (Maximum 400 Pounds), close Product Mixer Safety Cover.
 - b. Push the mix green start button only. During this mix operation seasonings may be added through the sight holes in the Product Mixer Safety Cover.
 - c. After the desired mix, push the green grind start button to operate grinding auger and grind out product.
 - d. Push the red stop button when all product has been ground out.
4. Unplug from power source and perform lockout/tagout procedures.

CLEANING



ROTATING GRINDING AUGER & ROTATING MIXING PADDLE TO AVOID SERIOUS PERSONAL INJURY

- **ALWAYS** Turn Off, Unplug From Power Source and Perform Lockout/Tagout Procedures to This Machine **Before** Cleaning or Servicing.
- **ONLY** Use Recommended Cleaning Equipment, Materials, and Procedures.
- **NEVER** Spray Water or Other Liquid Substances Directly at Motor, Power Switch or any Other Electrical Components.
- **ALWAYS** Thoroughly Clean Equipment at Least Daily.

CLEANING THE BIRO MIXER GRINDER

1. Disconnect mixer grinder from power source and perform lockout/tagout procedures.
2. Remove grinding bowl end ring, breaker plate, knife and grinding auger.
3. Remove mixing paddle. Be sure front most paddle arm is pointing up. Loosen the thumb screw on the mixer paddle lock arm (Item No. [53852](#)). While supporting the mixing paddle, remove the lock arm. Turn the mixing paddle counterclockwise, slide forward to disengage from drive shaft and lift from product hopper.



DO NOT POWER SPRAY DIRECTLY AT ELECTRICAL COMPONENTS

4. Machine is now ready to be cleaned using warm soapy water and rinsed with clean water. Machine may be cleaned by power spray washing, taking care to not spray directly at any electrical controls.
5. The grinding head can be removed for cleaning if desired. This is accomplished by removing the three nuts on the back flange of the grinding head.
6. After machine has been cleaned and allowed to dry, all exposed metal surfaces should be coated with a good food grade light oil or grease.

CLEANING THE BOWL - RING AND WORM CARE OF TIN COATED PRODUCTS (DO'S AND DON'TS)

1. Do not use abrasive cleaning materials, such as brillo pads or metal scrapers. Tin is a soft metal and should be cleaned with a soft cloth and dried.
2. Do not use a cleaning agent containing a high percentage of free alkali or acid.
3. Do not use a detergent containing a high percentage of tri-sodium phosphate or meta-silicate. Tin is reactive to both.
4. Rinse well and dry thoroughly after washing to remove agents that may be reactive to tin.
5. If sterilizing agent containing chlorine is used, the tinned surface must be thoroughly rinsed. Chlorine is corrosive to tin.
6. Dry thoroughly after rinsing and store in a dry environment.
7. If water is exceptionally hard, drying will be necessary to prevent spotting.

MAINTENANCE



ROTATING GRINDING AUGER & ROTATING MIXING PADDLE TO AVOID SERIOUS PERSONAL INJURY

- **ALWAYS** Turn Off, Unplug from Power Source and Perform Lockout/Tagout Procedures to This Machine **BEFORE** Servicing.
- **NEVER** Touch This Machine Without Training and Authorization By Your Supervisor
- **NEVER** Place Hands Into Machine Input or Output Openings.
- **NEVER** Bypass, Alter or Modify This Equipment in Any Way From Its Original Condition.
- **PROMPTLY REPLACE** Any Worn or Illegible Warning Labels.
- **USE ONLY GENUINE BIRO** Parts and Accessories Properly Installed.

A. GRINDING BOWL INSTALLATION

1. Mount the grinding bowl on the three threaded studs on the front of the machine. Tighten in position with provided nuts.
2. Place the grinding auger in the grinding bowl and fully seat rear drive tang into auger drive shaft.
3. Install knife, breaker plate and end retaining ring.



ONLY HAND TIGHTEN RETAINING RING

4. When the bowl assembly is mounted and tight, there should be approximately $\frac{1}{8}$ " gap between the back inside wall of the grinding trough and the back of the auger. The bowl ring wrench which is provided with each mixer grinder is used only for **REMOVAL** of the end retaining ring for cleaning purposes or for changing knife and breaker plate.

B. MIXING PADDLE INSTALLATION

1. Holding the mixing paddle by the center shaft and with the front blade up carefully fit drive male collar into the end of the drive shaft. Insert paddle lock arm assembly (Item No. [53852](#)) into the front of the mixing tub and onto the front of the mixing paddle.
2. When fully seated, turn the lock arm counterclockwise so the protruding arm is behind the lock set screw bracket. Tighten the mixer paddle lock set screw (Item No. [53568](#)).

C. LUBRICATION

1. **MOTORS:** The mix and grind motors have pre-lubricated bearings. These bearings should be re-lubricated annually with a good grade of bearing grease. Do not over-grease.
2. **BEARING HOUSING:** The main bearings are housed in an enclosed and sealed journal box. Re-lubricate semi-annually with a good grade of bearing grease. Do not over-grease. This may cause seal damage.

No. 60027 WINSMITH GEAR REDUCER LUBRICATION AND MAINTENANCE

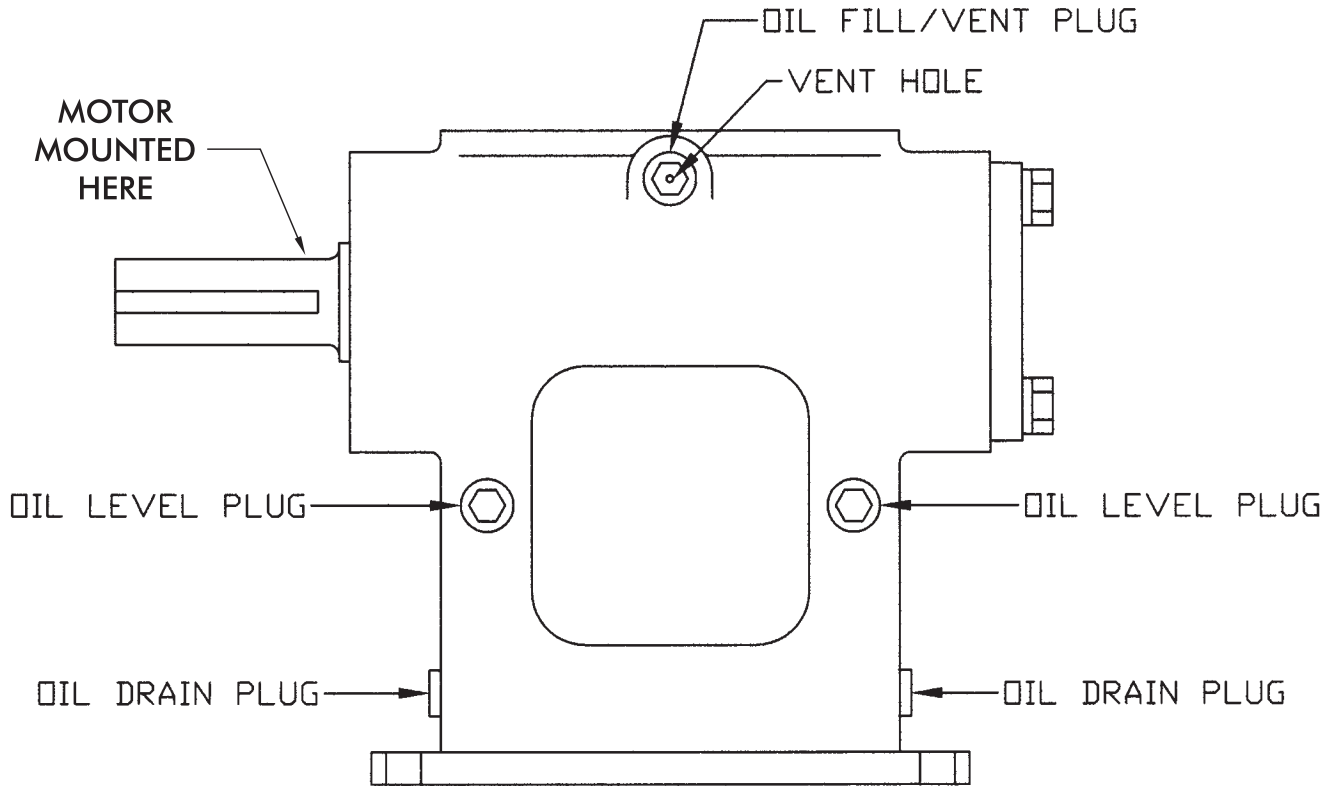

VIEW IS FROM OPPOSITE SIDE OF DRIVEN SHAFT LUBRICANTS FOR WORM GEAR REDUCERS

The precision-made gears and bearings in Speed Reducers require high-grade lubricants of the proper viscosity to maintain trouble-free performance. For best results, use lubricants on the following chart for worm gear reducers.

	MINERAL OILS	SYNTHETIC OILS
Ambient Temperature	16 to 50°F	96 to 131°F
Final State Worm Speed	Up to 2000 FPM	Up to 450 FPM
ISO Viscosity Grade	460	680
AGMA Lubricant No.	#7 Compounded	8 S
Mobil	600W Super Cylinder	SHC 636
American Lubricants	AGMA #7 Gear Oil	N/A
Castrol	Tribol 1105-7C	Tribol 800/680
Chevron	Cylinder Oil W460	Tregra 680
Conoco	Inca Oil 460	N/A
Exxon (Esso)	Spartan EP 460	Teresstic SHP 680
Fiske Brothers	SPO-277	N/A
Shell	Valvata J 460	Omala RL 680
Texaco	Vanguard 460	Pinnacle 680

Standard factory-installed lubricant is Mobil Oil Corp. 600 W Super Cylinder Oil (AGMA7).

Some gear lubricants contain E.P. additives that can be corrosive to gear bronze material. Avoid lubricants that are compounded with sulfur and/or chlorine.

Lubricant selections are provided by the lubricant manufacturer based on AGMA recommended viscosity grades. Viscosity grades are based on Lubrication Standard ANSI/AGMA 9005-D94.

LUBRICATION (Cont.)

1. Factory Filling

The speed reducers are filled with Mobil 600W Super Cylinder oil at the factory to the proper level for the standard mounting position. The oil level should be checked and adjusted (if necessary) prior to operation, using the oil level plug provided and while the unit is oriented in its operating position.

2. Oil Changing

When changing oil for any reason, It should be remembered that oils of various types may not be compatible. Therefore, when changing to a different oil, it is recommended that the housing be completely drained and thoroughly flushed with a light flushing oil prior to refilling with the appropriate lubricant. The oil level should be rechecked after a short period of operation and adjusted, if necessary.

A. Initial Oil Change

Oil in the mixer transmission should be changed after the first four (4) weeks of operation. This is to remove the initial oil and also any small metal shavings that may have been generated during the mating of the gears.

B. Subsequent Oil Changes

After the initial oil change, subsequent changes should be performed every six (6) months. After draining the oil, refill the unit to the "level" plug on the side of the transmission with Mobil 600W Super Cylinder oil or equivalent.

C. Synthetic Oils

Synthetic lubricants can be advantageous over mineral oils in that they generally are more stable, have a longer life, and operate over a wider temperature range. These oils are appropriate for any application but are especially useful when units are subjected to low start-up temperatures or high operating temperatures. However, continuous operation above 225°F may cause damage to seals or other components. It is recommended that the initial oil be changed or filtered after the first 1500 hours of operation to remove metal particles that accumulate during break-in. Subsequent oil changes should be made after 5000 hours operation if the units are operating in a clean environment. This can be extended to 10,000 hours if using new reformulated Mobil SHC 636 lubricants (orange in color) and the lubricant remains free of contamination over this period.

3. PROCEDURE FOR REPLACING OIL IN MIXER TRANSMISSION

- a. Unplug mixer grinder from power source and perform lockout/tagout procedures.
- b. Remove rear drive cover or access cover.
- c. Remove vent plug on the top side of the gearbox and the oil level plug from the side of the gearbox.
- d. With a container in place to catch old oil, remove the lower drain plug on the side of the gearbox.
- e. When all oil has drained, clean the drain plug and re-install in the gearbox.
- f. Refill the gearbox with Mobil 600W Super Cylinder oil or equivalent until oil appears at the bottom of the oil level hole. Approximately 3.1 pints of oil
- g. Replace oil level and vent plugs.
- h. Reinstall rear drive cover or access cover.

4. Overfilling or Underfilling

If a speed reducer is overfilled with oil, the energy used in churning the excessive oil can result in overheating. If this occurs, shut down the drive, remove the oil level plug and allow oil to drain until oil ceases to drain from the level hole, reinstall the oil level plug and restart the drive. If the speed reducer is underfilled, the resultant friction can cause overheating and possible damage. If this occurs, fill the speed reducer to the oil level plug hole and check the gearing for excessive wear.

5. Oil Seals

Although the speed reducer uses high quality oil seals and precision ground shafts to provide a superior seal contact surface, it is possible that circumstances beyond the speed reducer's control can cause oil seal leakage (damage during shipment or installation, etc.). When replacing a shaft oil seal, using the following suggestions will help to insure leak-free operation and long seal life.

- A. When installing a new seal, cover the keyway and any other surface discontinuity with smooth tape to protect the seal lip from being damaged.
- B. A sealant should be used between the O.D. of the seal and the I.D. of the bore into which the seal is installed. The seal bore should also be free of any burrs, nicks, or scratches.
- C. Be sure that the seal is not cocked in the seal bore. The outer face of the seal should be flush with the surface into which it is mounted.

D. SPUR GEARS LUBRICATION

Gears should be checked after the first two weeks of operation. Then every 6 weeks, depending on hour's used or severe duty every 2 weeks. Recommended types of spur gear lubricant are those with Lithium soap base. Also bonded lubricants such as Shell Cassida EPS Grease 2 or equivalent for Spur Gears. The lubricant should be of a viscosity whereby it will stick and bond to the working surfaces to reduce heat and wear to the Spur Gear Teeth.

- a. Unplug mixer grinder from power source and perform lockout/tagout procedures.
- b. Remove rear drive cover or access cover.
- c. Spray or brush lubricant on teeth of the Spur Gears complete.
- d. Reinstall rear drive cover.

E. MIXER DRIVE GEAR ADJUSTMENT

Unplug mixer/grinder from power source and perform lockout/tagout procedures.

Remove rear drive cover.

Loosen the four bolts and adjustment bolt holding the 5 hp motor and transmission to its mounting plate.

Slide Mixer Transmission to the right.

When the Spur Gears are interlocked leave a little clearance, about $\frac{1}{64}$ " - $\frac{1}{32}$ ".

Do Not Bottom Out the Gear Teeth into the Other Driven Gear.

This will put excessive and damaging pressure on the transmission bearings and mixer drive shaft bearings. Check with a straight edge from the large spur gear across the face to the face of drive spur gear in two different locations. The spur gears must be aligned. Tighten the adjustment bolt up to the transmission and tighten jam nut. Tighten the four bolts to the transmission and mounting plate. Check the spur gear alignment again. See Lubrication.

Reinstall rear drive cover.

F. MAIN DRIVE CHAIN AND SPROCKET LUBRICATION:

The main drive chain has been pre-lubricated at the factory to protect it against dirt and moisture. Chain life will vary appreciably depending upon its lubrication. The better the lubrication, the longer the chain life.

Lubrication effectiveness will vary with the amount of lubricant and frequency of application. Ideally, a lubricant film should always be present between the working parts. Manually lubricate the chain as often **as is needed** (possibly once a week). **NEVER** exceed three months without lubricating.

Lubricating just the outside of the chain does little good. Apply lubrication on the inside of the chain span so that it will work through the moving parts and joints by centrifugal force as the chain rotates and reaches the area where one surface "scrubs" another.

Recommended types of chain lubricant are those with Molybdenum Disulphide or Graphite added. Also bonded lubricants such as Dow Corning Molykote 321R or equivalent are excellent for open chains. The lubricant should be of a viscosity whereby it will "flow" somewhat and penetrate the internal working surfaces. Thick stiff greases are of little value because they cannot work into the moving parts of the chain.

- a. Unplug mixer/grinder from power source and perform lockout/tagout procedures.
- b. Remove rear drive cover.
- c. Spray or brush lubricant on inside of chain, slowly and carefully turning large sprocket by hand.
- d. Reinstall rear drive cover.

G. MAIN DRIVE CHAIN TENSION (See Diagram Below)

1. Unplug mixer/grinder from power source and perform lockout/tagout procedures.
 2. Remove rear drive cover.
 3. Loosen the four bolts that hold the motor to the frame of the machine.
 4. Loosen the lock nuts on the motor adjusting stud.
 5. **To Loosen Chain Tension.** Turn motor adjusting studs counterclockwise. Grasp motor and pull toward adjusting stud. Be sure to turn both adjusting studs the same amount and evenly. Total chain flex should be $\frac{1}{8}$ " to $\frac{3}{8}$ ". Be sure to keep motor shaft **parallel** with auger drive shaft.
- To Tighten Chain Tension.** Turn motor adjusting studs clockwise. Be sure to turn both adjusting studs the same amount and evenly. Total chain flex should be $\frac{1}{8}$ " to $\frac{3}{8}$ ". Do not overtighten chain as this will put excessive and damaging pressure on the motor bearings. Be sure to keep motor shaft **parallel** with auger drive shaft. Be sure the sprockets are inline.
6. Retighten motor mounting bolts.
 7. Retighten motor adjusting stud lock nuts.
 8. Reinstall the rear drive cover.

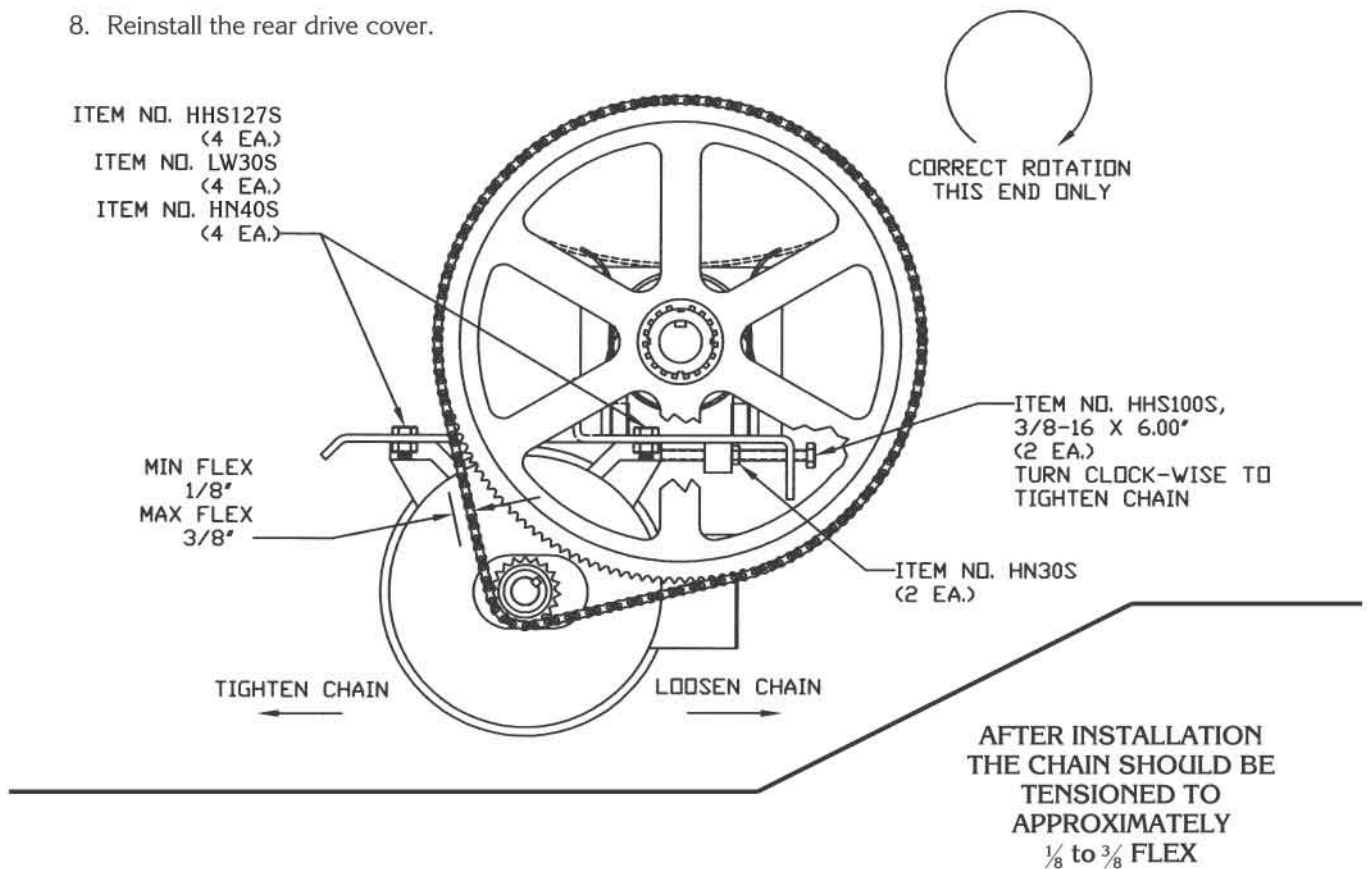

H. CHAIN REPLACEMENT

1. Part No. H384-CL Service Replacement Chain is provided with a "Connecting Link" (Part No. H384-LINK) so that it can be separated to facilitate installation over the sprockets

Upon assembly, be sure the connecting link is installed so the spring clip is orientated with its opening facing "opposite" the direction of the chain travel (See Diagram). →

SPRING CLIP

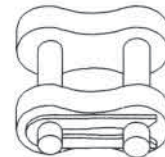

“Eagle” Drive Belt

Tensioning Instructions

1. Place a straight edge on top of the belt and across both sprockets as shown in the diagram.
2. Set the large O-Ring at the 1st Graduation (1/8” line) on the Tension Tester, Item No. #H384-EAGL-TSTR.
3. Set the small O-Ring on the deflection force scale to zero.
4. Place the tension tester squarely on the belt at the center of the belt span (see Diagram).
5. Apply a force to the plunger until the large O-Ring is even with the bottom of the straight edge which has been placed across both sprockets (1/8” belt deflection).
6. Remove the tension tester and read the force recorded from the bottom of the small O-Ring on the force scale.
7. The force should be equal to the value indicated in the force table #1-7 depending on the “HP” of the grinder, and if the belt is “new” or “used.”
8. If the force values do not equal those shown in table #1-7, increase the tension as follows:
 - a. Loosen the 4 motor mounting bolts (A) slightly.
 - b. Advance the jacking screws (B) ¼ turn each (be sure to advance both screws an equal amount).
 - c. Retighten the motor mounting bolts.
 - d. Re-check the belt tension according to the above procedure.

Do not rely on “feel” for the proper belt tension as this typically results in belts that are under-tensioned.

Loose belts will fail due to “ratcheting” (jumping a tooth), tooth shearing, and breakage.

AFMG-52-4 FRONT VIEW PARTS DIAGRAM

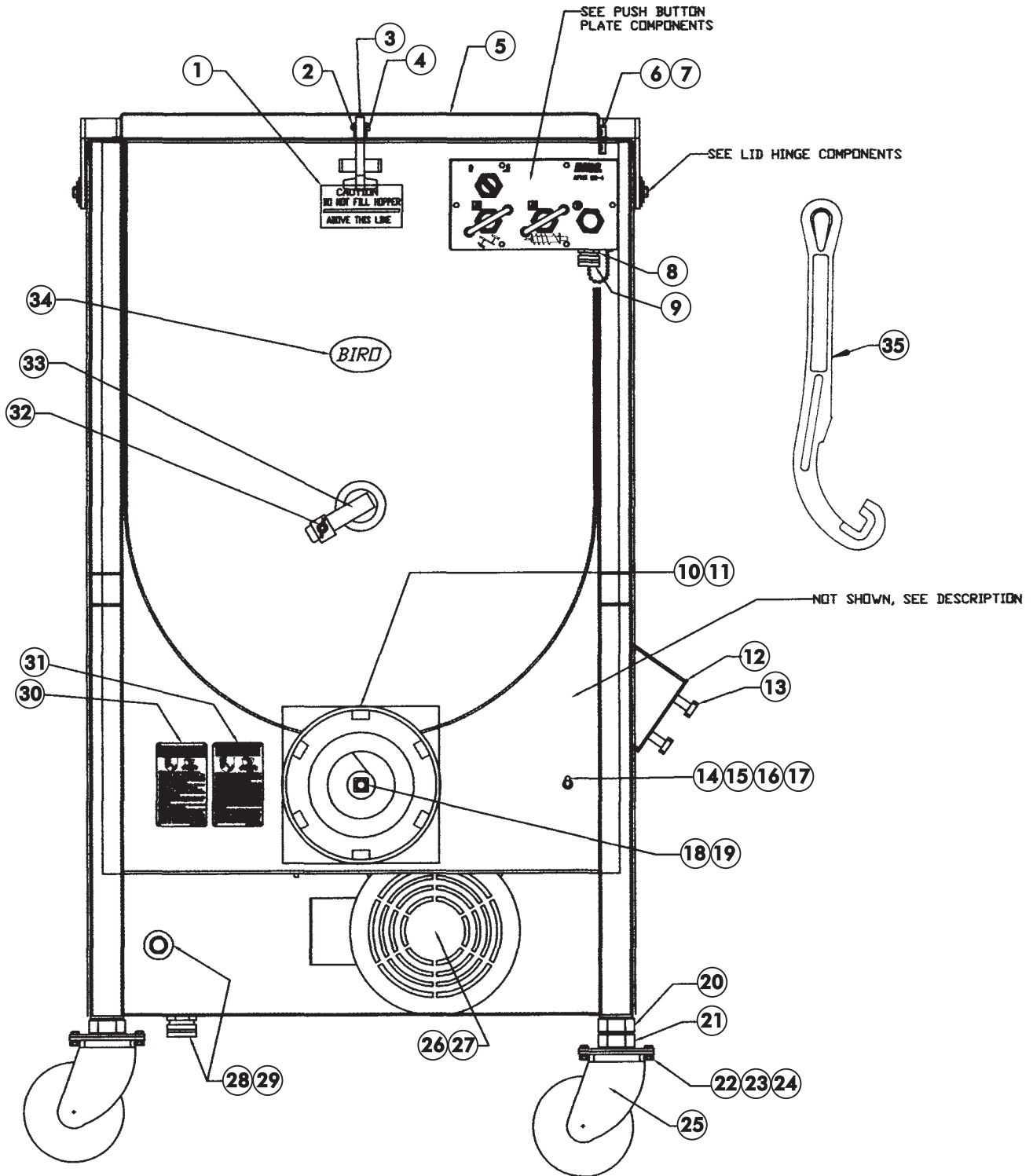

AFMG-52-4 FRONT VIEW PARTS LIST

Fig.	Item No.	Description
1	53687	Decal, Do Not Fill Above This Line
2	RHS31S	1/4-20 x 3/4 round head screw
3	56072	Safety cover latch
4	HNNL15S	1/4-20 heavy nylok nut
5	43015	Safety cover, 400 lb. 52 hopper
6	PC168	Safety switch
7	60072	Safety switch magnet
8	52655	Female receptacle, footswitch
9	52662	Protective cap assembly
10	57023-CTN	Bowl w/plate pins
11	HR52	Ring
12	54303	Outer disc, double rod
13	14688	4 point knob, 3/8-16 thread (2 req'd.)
14	53715	Ring wrench hanger
15	FW05S	1/4 flat washer, S.S.
16	LW10S	1/4 lock washer, S.S.
17	HN15S	1/4-20 hex nut, S.S.
18	HK52/56	Knife drive pin
19	57022-CTN	Auger assembly
20	HN68S	1 1/4-7 hex nut, S.S. (4 req'd.)
21	60120	Foot assembly, caster, (4 req'd.)
22	HHS070S	3/8-16 x 1.00 hex head screw, S.S., (16 req'd.)
23	FW16S	5/16 (.380 ID) flat washer, S.S., (32 req'd.)
24	AN20S	3/8-16 acorn nut, S.S., (16 req'd.)
25	60123	Swivel caster w/slide lock (4 req'd.)
26	57025	Motor, 10HP, 208/230/460V/60HZ/3Ph
27	57025-5	Motor, 10HP, 575V/60HZ/3Ph
28	57103-SOW	Cord grip connector, 1.00, 7/8-1.00 (5 req'd.)
29	57103-1	Lock nut, strain relief, 1.00
30	H653-E	Grinder warning label, English
31	H653-SP	Grinder warning label, Spanish
32	53568	Mixer paddle lock set screw
33	53852	Lock arm assembly w/bearings
34	VTS7181	Biro world decal
35	52357	Ring wrench (order H340)
NOT SHOWN		
	VT460S	Model/serial no. plate
	T3059-2-1A	Pop rivet, (12 req'd. for all tags)
	43040	Side inlet seal, double rod, 35 degree

AFMG-52-4 SIDE VIEW PARTS DIAGRAM

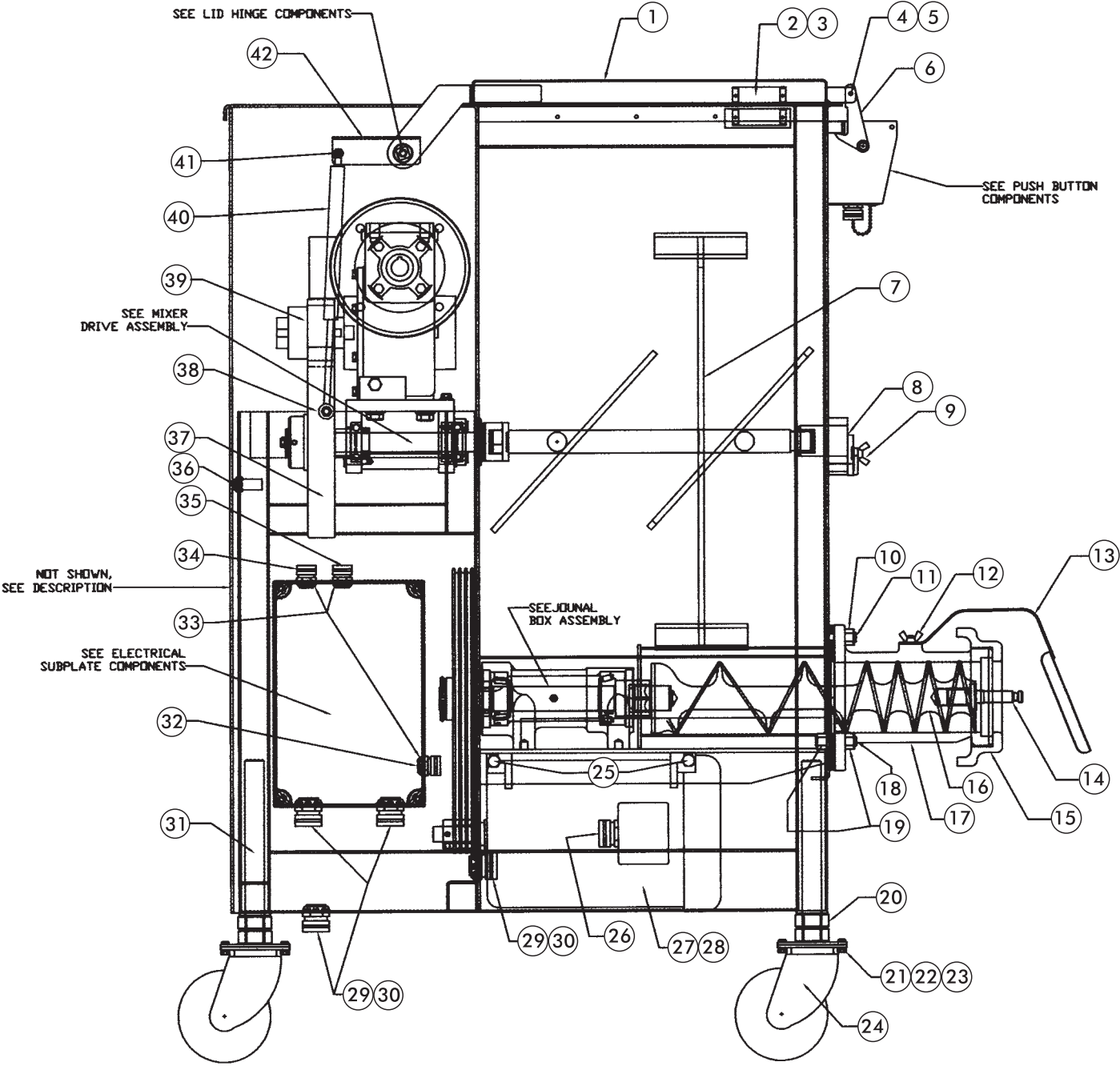

AFMG-52-4 SIDE VIEW PARTS LIST

Fig.	Item No.	Description
1	43015	Safety cover, 400 lb. 52 hopper
2	PC168	Safety switch
3	PC169	Safety cover magnet
4	HHS040S	1/4-20 x 3/4 hex head screw, S.S.
5	AN15S	1/4-20 acorn nut
6	56072	Safety cover latch
7	43020	Mixer paddle assembly, 2 nd grind
8	53852	Lock arm assembly w/bearings
9	53568	Mixer paddle lock set screw
10	HN40S	1/2-13 hex nut, S.S. (1 req'd.)
11	53413	1/2-13 x 1.75 bowl mounting stud (1 req'd.)
12	WN20S	3/8-16 wing nut, S.S.
13	52392	Meat guard splash shield
14	HK52/56	Knife drive pin
15	HR52	Ring
16	57022-CTN	Auger assembly
17	57023-CTN	Bowl w/plate pins
18	53413-2	1/2-13 x 2.375 bowl mounting stud (2 req'd.)
19	HN40S	1/2-13 hex nut, S.S. (4 req'd.)
20	HN68S	1 1/4-7 hex nut, S.S. (4 req'd.)
21	HHS070S	3/8-16 x 1.00 hex head screw, S.S., (16 req'd.)
22	FW16S	5/16 (.380 ID) flat washer, S.S., (32 req'd.)
23	AN20S	3/8-16 acorn nut, S.S., (16 req'd.)
24	60123	Swivel caster w/slide lock (4 req'd.)
25	HHS100S	3/8-16 6.00 hex head screw (2 req'd.)
26	57103-SOW	Cord grip connector, 1.00, 7/8-1.00
27	57025	Motor, 10HP, 208/230/460V/60HZ/3Ph
28	57025-5	Motor, 10HP, 575V/60HZ/3Ph
29	57103-SOW	Cord grip connector, 1.00, 7/8-1.00 (5 req'd.)
30	57103-1	Lock nut, strain relief, 1.00 (5 req'd.)
31	60120	Foot assembly, caster (4 req'd.)
32	224-4	Cord grip connector, 1/2, .625-.750
33	224-1N	Conduit nut, 1/2 (3 req'd.)
34	224-5	Cord grip connector, 1/2, .375-.500
35	14672	Cord grip connector, multiple hole
36	PC166	Rear cover safety switch
37	40426	Driven gear, 60 teeth
38	EMG62062-1	Ball stud, gas spring (2 req'd.)
39	40425	Drive gear, 20 teeth
40	EMG62190	Gas spring, internal (2 req'd.)
41	EMG62062-1	Ball stud, gas spring (2 req'd.)
42	40444	Lid damper arm, right hand

NOT SHOWN

43010	Rear cover
PC084	Safety switch magnet

AFMG-52-4 BACK VIEW PARTS DIAGRAM

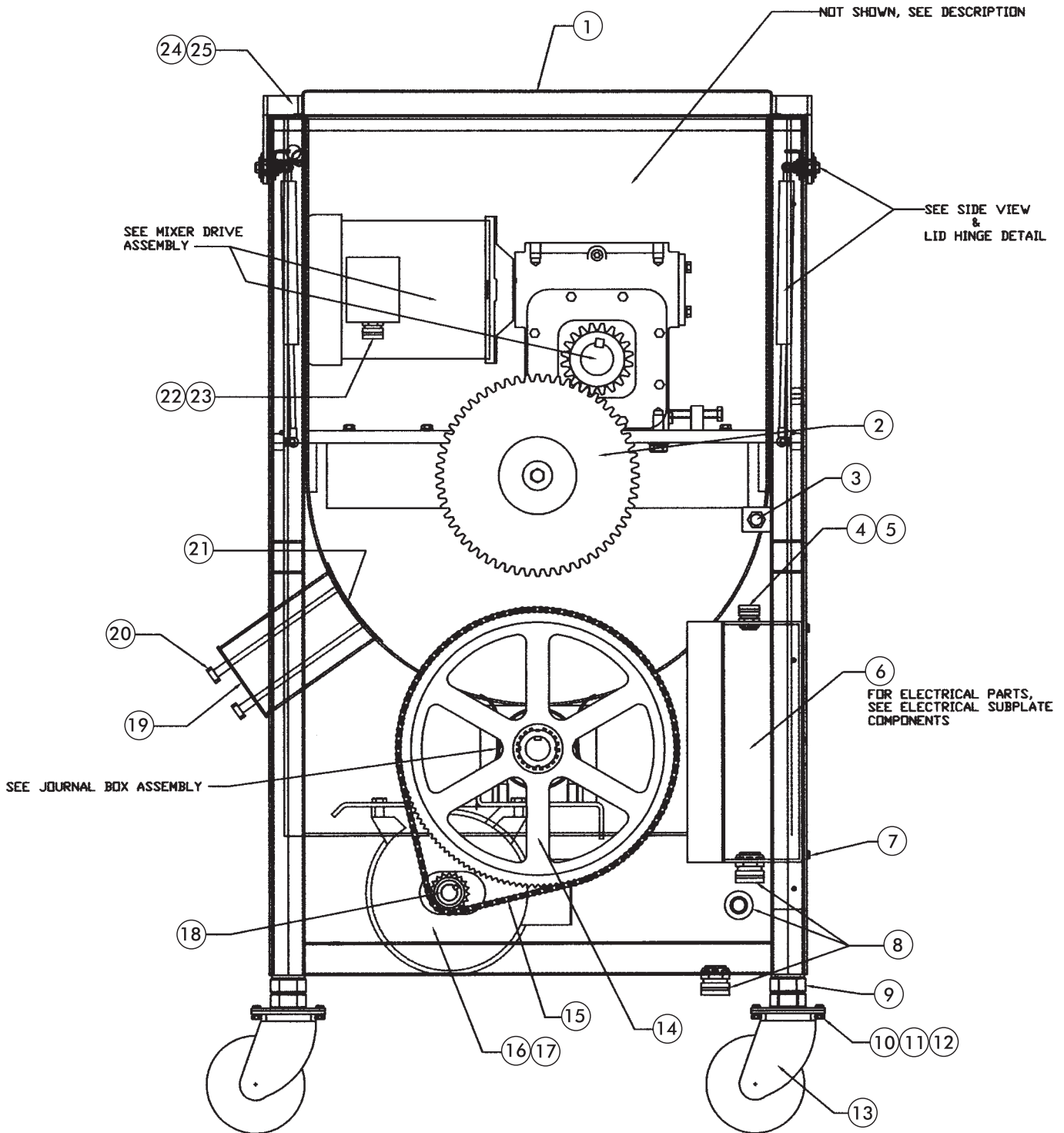

AFMG-52-4 BACK VIEW PARTS LIST

Fig.	Item No.	Description
1	43015	Safety cover, 400 lb. 52 hopper
2	40426	Driven gear, 60 teeth
3	PC166	Back panel safety switch
4	224-5	Cord grip connector, 1/2, .375-.500
5	224-1N	Lock nut, strain relief
6	40448	Watertight electrical enclosure
7	HHSM048S	M6 x 1 x 35mm hex head screw (4 req'd.)
8	57103-SOW	Cord grip connector, 1.00, 7/8-1.00 (5 req'd.)
9	HN68S	1 1/4-7 hex nut, S.S. (4 req'd.)
10	HHS070S	3/8-16 x 1.00 hex head screw, S.S. (16 req'd.)
11	FW16S	5/16 (.380 ID) flat washer (32 req'd.)
12	AN20S	3/8-16 acorn nut, S.S. (16 req'd.)
13	60123	Swivel caster w/slide lock (4 req'd.)
14	53727	Main sprocket, 141 teeth
15	H384-CL	Roller chain w/connecting link
16	57025	Motor, 10HP, 208/230/460V/60HZ/3Ph
17	57025-5	Motor, 10HP, 575V/60HZ/3Ph
18	H382-1	Motor pinion, 22 teeth
19	54303	Outer disc, double rod
20	14688	4 point lock knob, 3/8-16 thread (2 req'd.)
21	43040	Side inlet seal, 35 degree, double rod
22	224-3	Cord grip connector, 1/2, .625-.750
23	57103-1	Lock nut, strain relief
24	PC168	Safety switch
25	PC169	Safety switch magnet
NOT SHOWN		
	43010	Rear cover
	PC084	Safety switch magnet

AFMG-52-4 MIXER DRIVE ASSEMBLY

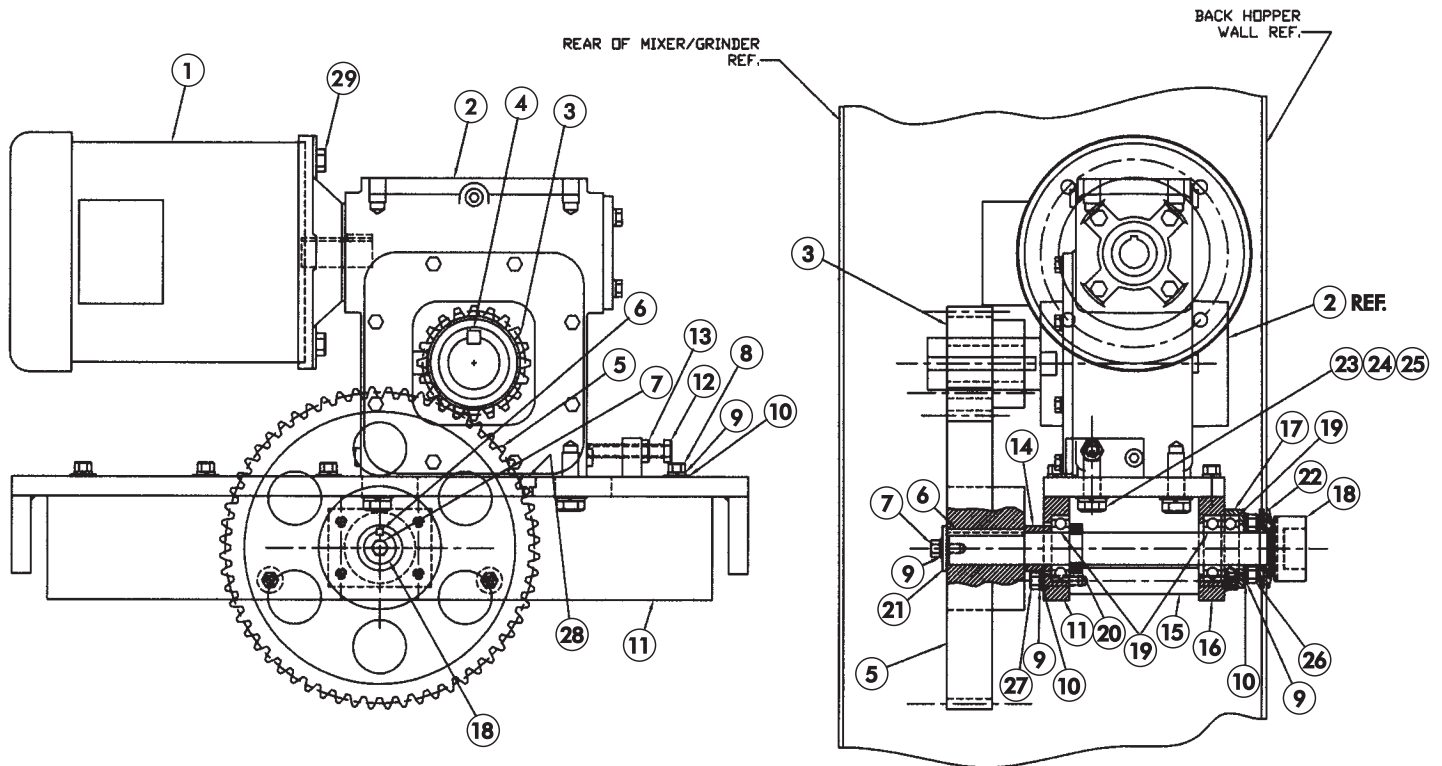

Fig.	Item No.	Description
1	60028	Mixer motor, 5HP, 208-230/460V/3PH/60Hz
2	60027	Mixer transmission, 25:1 ratio
3	40425	Drive gear, 20 tooth spur gear
4	52413	Key, mixer drive gear – 1/2 sq. x 3"
5	40426	Driven gear, 60 tooth spur gear
6	60030	Key, mixer driven sprocket
7	HHS070S	Hex head cap screw, 3/8-16 UNC x 1" stn. stl.
8	HHS083S	Hex head cap screw, 3/8-16 UNC x 1 3/4" stn. stl.
9	LW20S	Lock washer, 3/8 stn. stl.
10	FW07S	Flat washer, 3/8 stn. stl.
11	43009	Bearing mounting plate rear, paddle drive shaft
12	HHS136S	Hex head cap screw, 1/2-13 UNC x 3" stn. stl.
13	HN42S	Hex nut, 1/2-13 UNC stn. stl.
14	60043	Spacer, driven spur gear
15	60041	Spacer, paddle drive shaft brg. mnt. plate
16	43008	Bearing mounting plate front, paddle drive shaft
17	60024	Cap, front bearing mtg. plate
18	60047	Paddle drive shaft, LH female
19	60054	Bearing, 1 1/4 bore single row ball bearing
20	60042	Locking collar, 2 pcs.
21	60050	Washer, paddle drive shaft
22	53953	Seal, mixer drive shaft
23	HHS147S	Hex head cap screw, 5/8-11 UNC x 2" stn. stl.
24	LW35S	Lock washer, 5/8 stn. stl.
25	FW17S	Flat washer, 5/8 stn. stl.
26	HHS083S	Hex head cap screw, 3/8-16 UNC x 1 3/4" stn. stl.
27	HHS083S	Hex head cap screw, 3/8-16 UNC x 1 3/4" stn. stl.
28	SHS080S	Socket head cap screw, 3/8-16 UNC x 1 1/2" stn. stl.
29	HHS127S	Hex head cap screw, 1/2-13 UNC x 1 1/2" stn. stl.

LID HINGE COMPONENTS

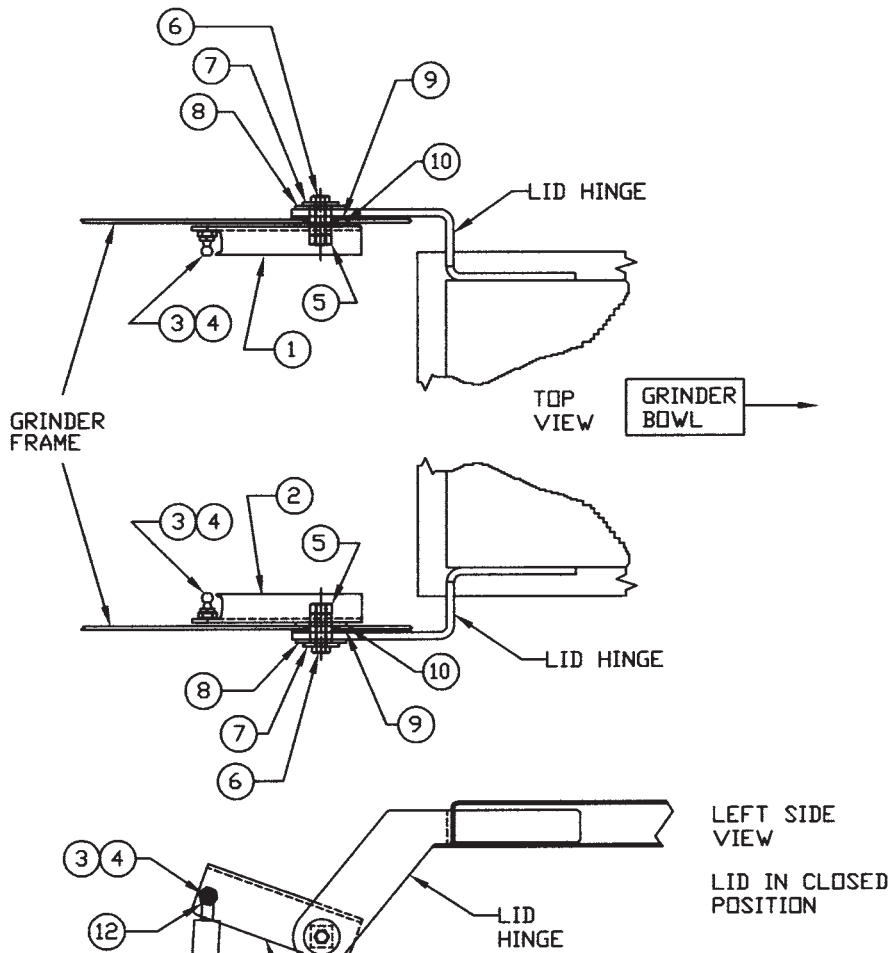
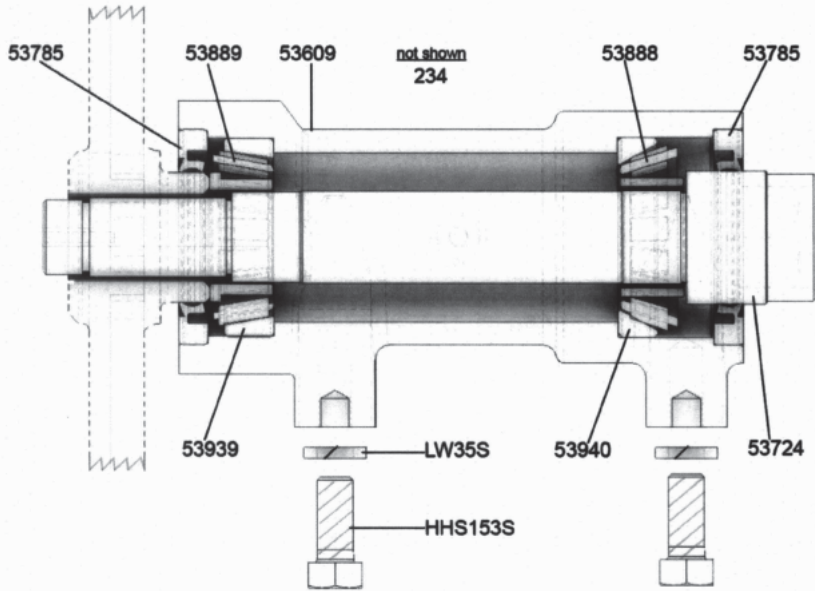

Fig.	Item No.	Description
1	40445	Lid damper arm, left hand
2	40444	Lid damper arm, right hand
3	EMG62062-1	Ball stud, gas spring (4 req'd.)
4	LW15S	5/16 lock washer (4 req'd.)
5	HNNL25S	3/8-16 Nylock hex nut (2 req'd.)
6	HHS083S	3/8-16 x 1 3/4 hex head screw (2 req'd.)
7	EMG92032	Washer, outside lid hinge arm (2 req'd.)
8	EMG62184	Washer, outside lid hinge arm (2 req'd.)
9	EMG62182	Sleeve bushing, hinge (2 req'd.)
10	EMG62181	Washer, inside lid hinge (2 req'd.)
11	EMG62190	Gas spring, internal (2 req'd.)
12	EMG62190-1	Retaining clip for gas spring (4 req'd.)

No. 53886 JOURNAL BOX ASSEMBLY

NO. 53886 JOURNAL BOX ASSEMBLY



Item No.	Description
53886	Journal box assembly complete
53609	Journal box housing, #62001 on
53724	Auger drive shaft, #62001 on
53785	Journal box seal (2 ea.)
53888,53940	Front bearing cup/cone assembly Order H310A
53889,53939	Rear bearing cup/cone assembly Order H311A
234	Grease fitting 1/8 NPT
LW35S	Lock washer 5/8 SS (4 ea.)
HHS153S	Hex head screw 5/8-18x1-1/2SS (4 ea.)

OPTIONAL STAINLESS STEEL BOWLS, AUGERS & RINGS

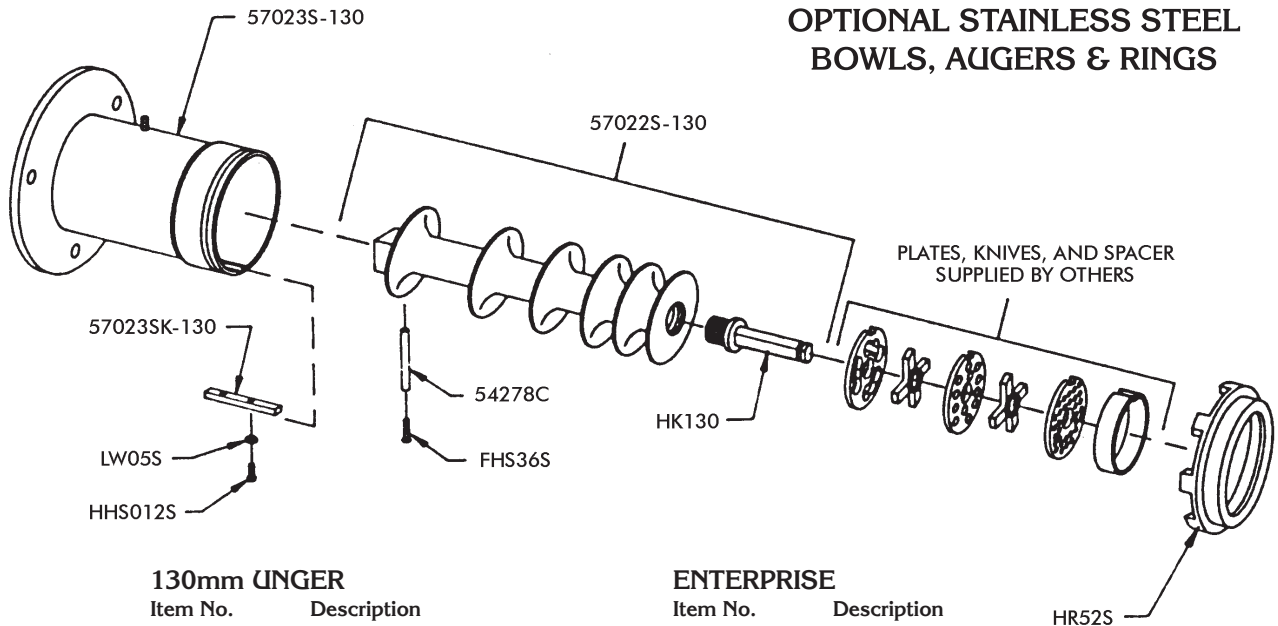

130mm UNGER

Item No.	Description
FHS36S	Shear pin fastener 1/4-20 x1 SS
HHS012S	Hex head screw, 10-32 x 1/2, SS
HK130	Knife drive pin, 130mm Unger
HR52S	End ring, SS
LW05S	Lock washer, #10, SS
54278C	Auger shear pin
57022S-130	Auger assembly, SS, 130mm Unger
57023S-130	Bowl, SS, 130mm Unger
57023K-130	Key, 130mm Unger

ENTERPRISE

Item No.	Description
HR52S	End ring, SS
57022S	Auger assembly, SS
57023S	Bowl, SS

AFMG-52-4 PUSHBUTTON PLATE COMPONENTS

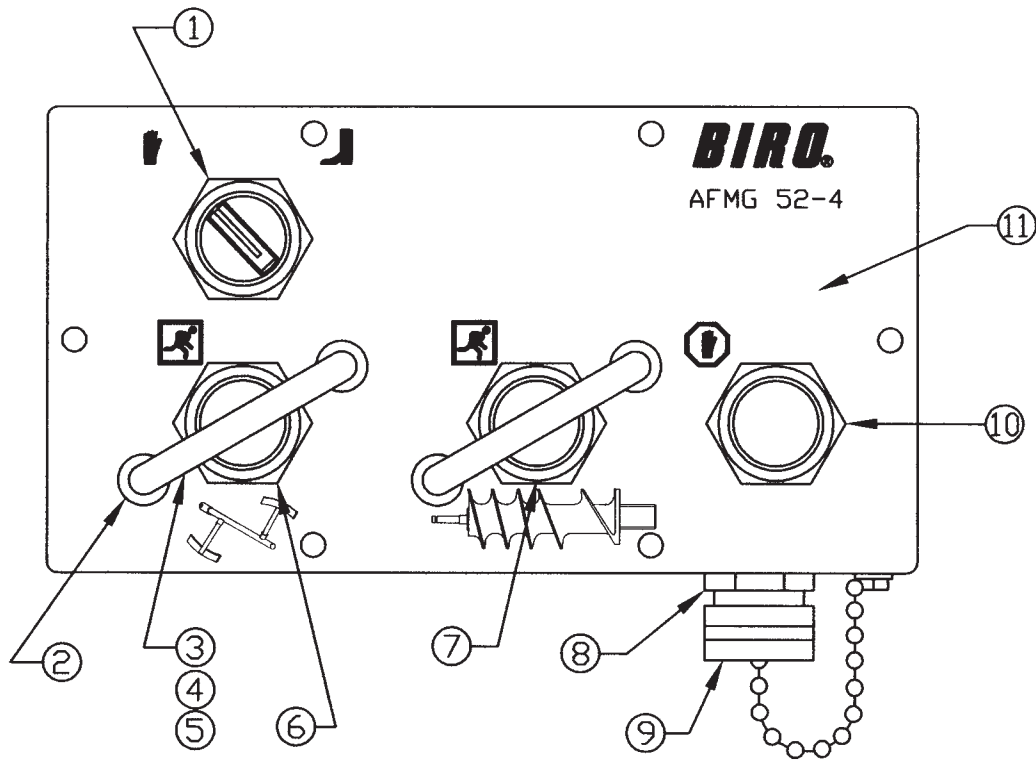

Fig.	Item No.	Description
1	EMG90668	Selector switch, 2 position hand/foot
2	H462-1	Trim ferrule – 4 req'd.
3	50655-1	Switch guard – 2 req'd.
4	LW15S	$\frac{5}{16}$ lock washer – 4 req'd. (opposite side, not shown)
5	HN20S	$\frac{5}{16}$ -18 hex nut – 4 req'd. (opposite side, not shown)
6	42MC-Y73	Start switch, mixer
7	42MC-Y73	Start switch, grinder
8	52655	Female receptacle, footswitch
9	52662	Protective cap assembly
10	42MC-Y74	Stop switch, all
11	43014	Front cover, pushbutton enclosure

AFMG-52-4 ELECTRICAL COMPONENT ASSEMBLY

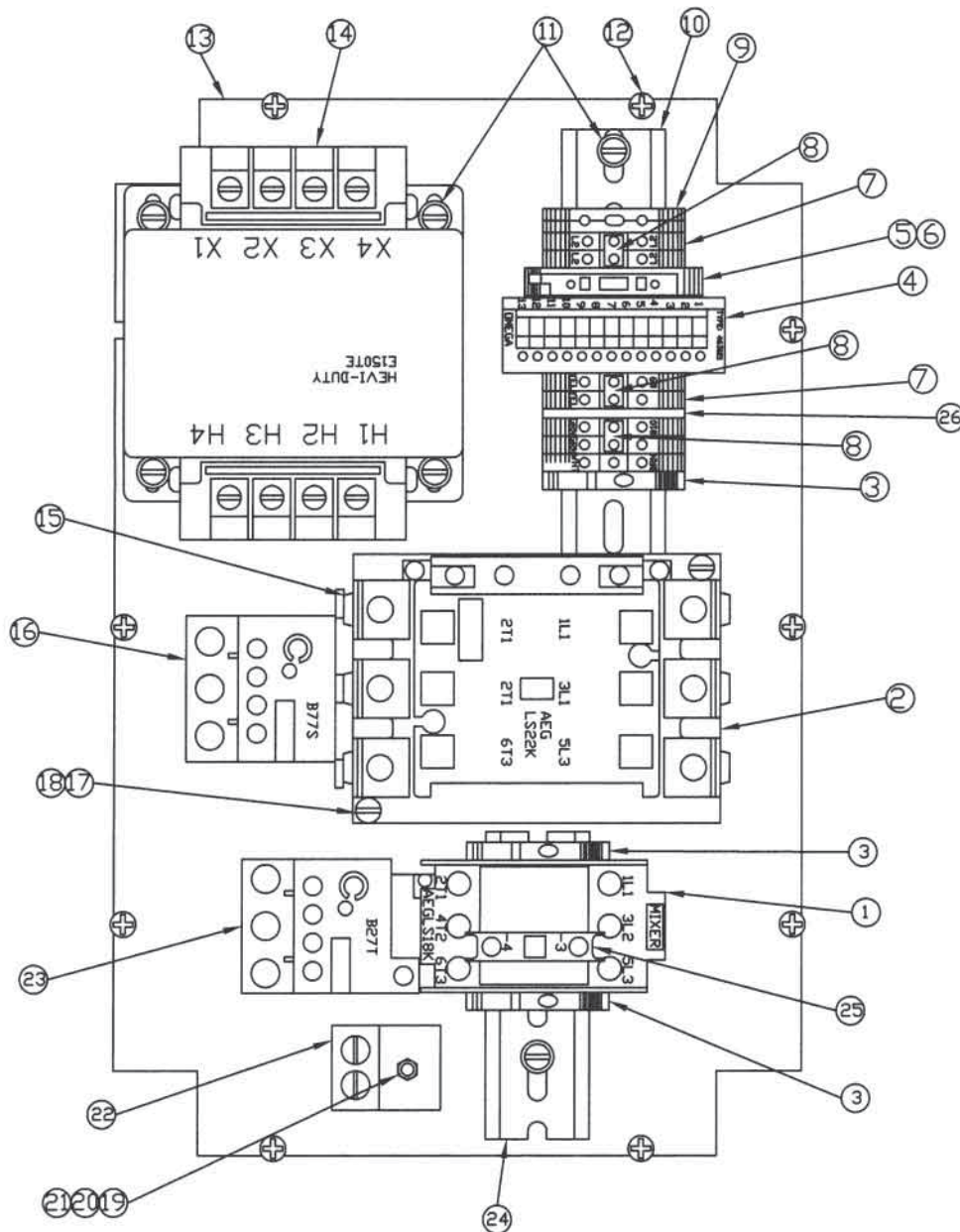
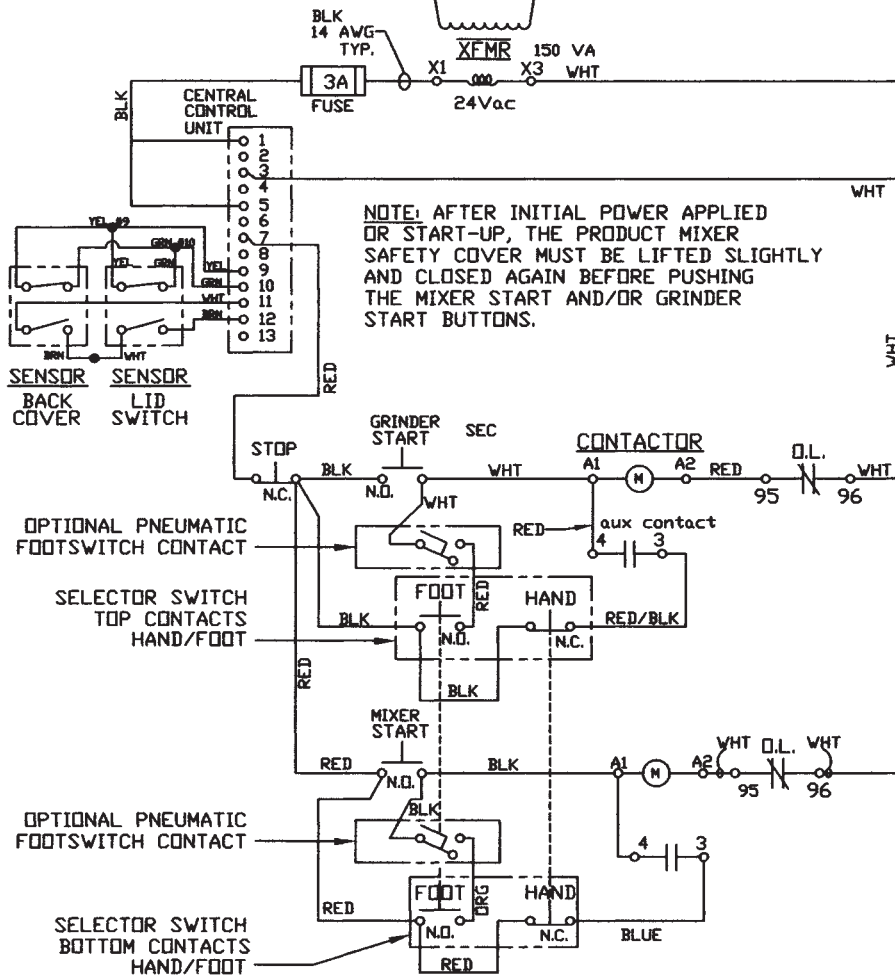
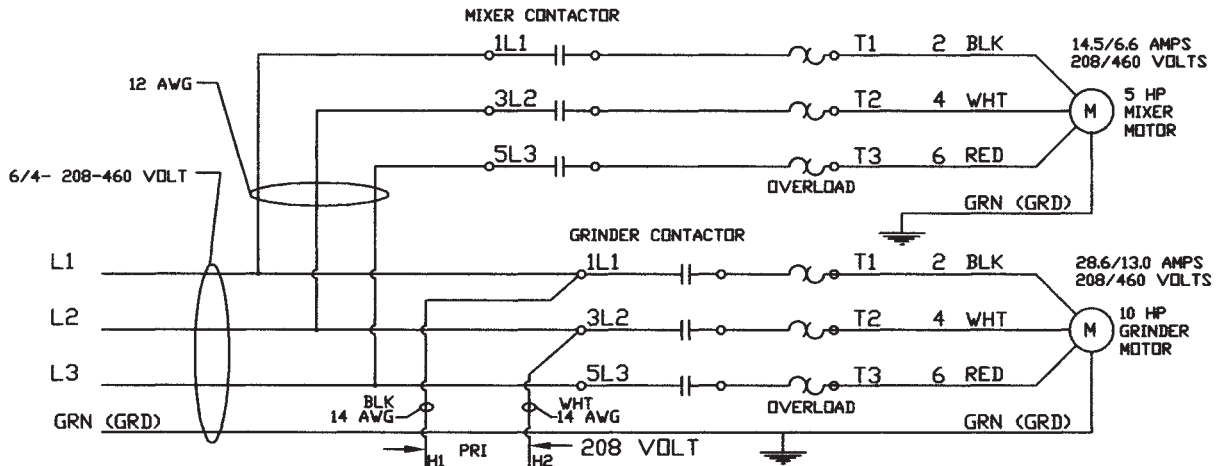
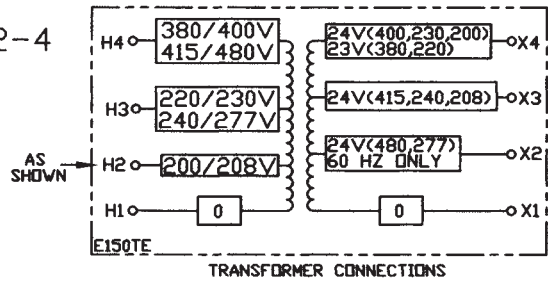
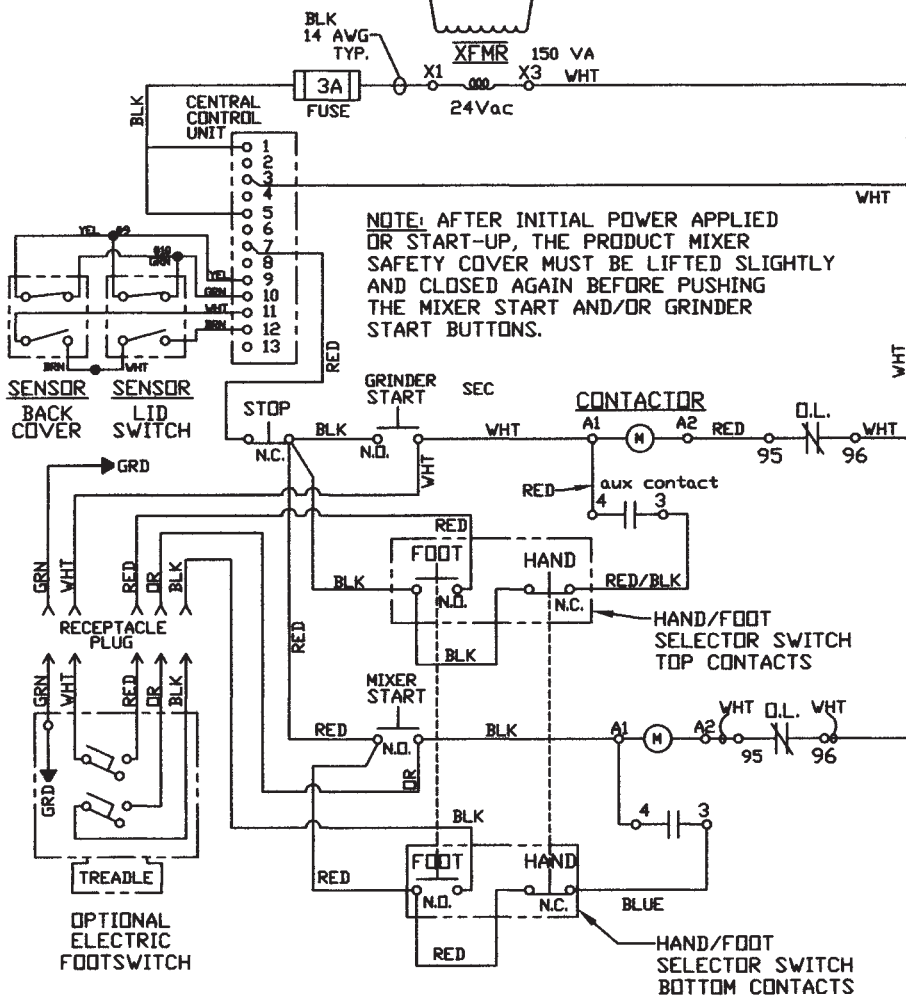
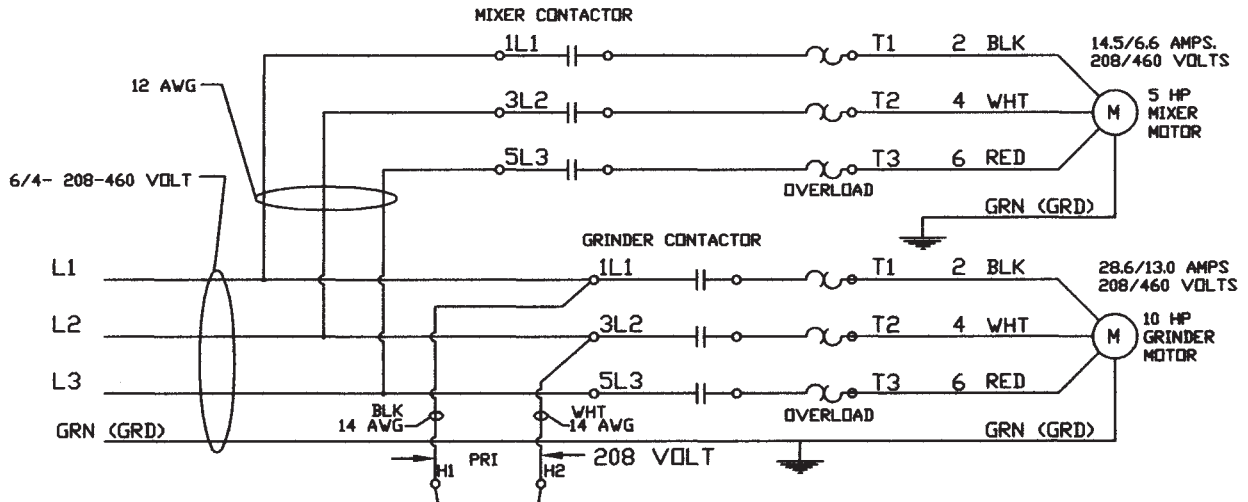
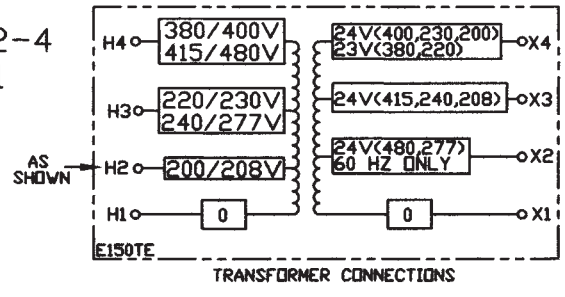

Fig.	Item No.	Description	Fig.	Item No.	Description
1	43037	Contactors LS18K, 24 VAC coil (208-460V)	15	EMG90249	Buss link – fits LS18K (BL-284) 440-480V
2	57027-AE-CE	Contactors LS22K 11-GO, 24 VAC coil (208-240V)	16	H281AE-330	Overload, 22-32 amp, B77S 20-32A (208-240V) or EMG90182 24-32 AMP (440-460V)
2	43037	Contactors LS18K, 24 VAC coil (440-460V)	16	H281AE-31	Overload, 11-17 amp, B27T-N 11-17A (440-460V)
3	BLK323	End barrier	16	EMG90181	Overload, 11.5 - 15 AMP, B55K - 15A (575 Volt)10 HP
4	PC162	Central control unit	17	RHS10S	10-32 x 3/8" round head screw, stn. stl.
5	EMG92014	Fuse block	18	FW04S	#10 flat washer, stn. stl.
6	EMG90552	Fuse, 3 amp, time delay	19	HHS040S	1/4-20 x 3/4" hex head cap screw, stn. stl.
7	PC152	Terminal, 7 req'd.	20	LW10S	1/4 lock washer, stn. stl.
8	PC257	Internal jumper	21	HN15S	1/4-20 hex nut, stn. stl.
9	BLK322	Ground block terminal	22	60103	Grounding block
10	60053	Din rail, 5 5/8"	23	H281AE-31	Overload B17S-N or B27T-N 11-17A (208-240V) same as 226 AE-OL17N
11	THS018S	#10-32 x 3/8" truss head screw, stn. stl.	23	226AE-OL08L	Overload B27T-L 5.6-8A (440-460V)
12	RHS075-ST	Round head self tap screw 10-16 x 1/2, stn. stl.	24	60052	Din rail, 4 1/4"
13	60051	Subplate	25	EMG90194	Aux. contact, N.O., – 1 req'd.
14	PC141-1	Transformer, 200/208/240-460-24VAC SEC	26	VTS582	End plate, terminal block
15	EMG90179	Buss link – fits LS22K, 30K, 37K (BL-283) 208-240V			

ELECTRICAL SCHEMATIC AFMG-52-4
 STARTING WITH SERIAL NO
 WITH PNEUMATIC FOOT SWITCH
 THREE PHASE



ELECTRICAL SCHEMATIC AFMG-52-4
 STARTING WITH SERIAL NO 524001
 WITH ELECTRIC FOOT SWITCH
 THREE PHASE



GRINDER MOTOR CONTACTOR W/OVERLOAD LS22K.11-G0

AUX CONTACT 3,4 N/D ATTACHED ON GRINDER MOTOR CONTACTOR

FOOT/HAND SELECTOR SWITCH SHOWN IN THE HAND MODE

MIXER MOTOR CONTACTOR W/OVERLOAD SP27.10-G0

AUX CONTACTS 3,4 N/D ATTACHED ON MIXER MOTOR CONTACTOR

ELECTRIC FOOT SWITCH ASSEMBLY No. 52668/54213

SWITCH WIRING DIAGRAM

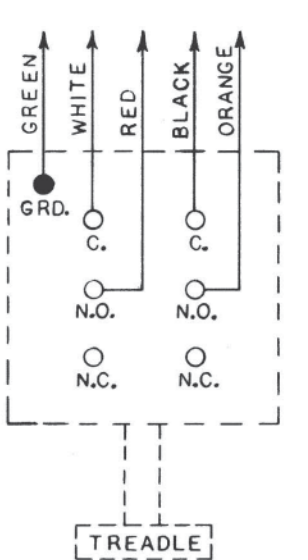

FOOT SWITCH ADJUSTMENT

To change adjustment of the operating point of an interior switch, depress the treadle to the point where you want the switch to operate. With the treadle depressed to the desired operating point, turn the adjusting screw until the switch snaps. Turn clockwise to lower the operating point and counter clockwise to raise it.

FOOT SWITCH WITHOUT COVER

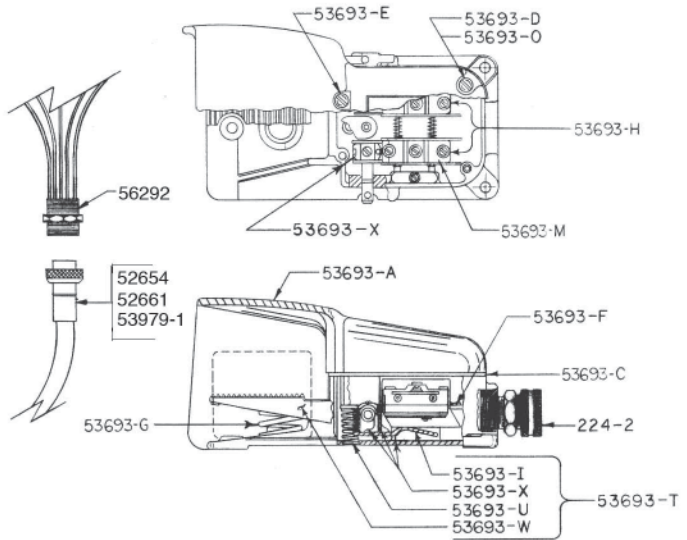
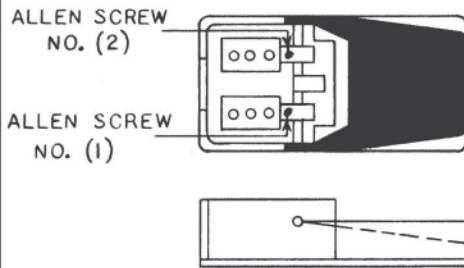

FOOTSWITCH PARTS LIST

- | | |
|---------|---|
| 224-2 | Cord connector, wt, straight, 3/4" |
| 52654 | Male plug w/6' cord, 5 wire |
| 56292 | Female receptacle, 90° |
| 52661 | Male plug w/12' cord, 5 wire |
| 52668 | Footswitch w/12' cord and plug |
| 53693 | Footswitch |
| 53693-A | Cover guard |
| 53693-C | Cover gasket |
| 53693-D | Cover screw - short |
| 53693-E | Cover screw - long |
| 53693-F | Ground screw |
| 53693-G | Treadle spring |
| 53693-H | Internal assembly complete |
| 53693-I | Actuator |
| 53693-M | Micro switch BA-2R62-A4 |
| 53693-O | Washer |
| 53693-T | Treadle w/actuator & return spring |
| 53693-U | Auxiliary treadle return spring |
| 53693-W | Treadle |
| 53693-X | One actuator & actuator spring assembly |
| 53979-1 | Cord 8' w/o Foot Switch |
| 54213 | Foot switch w/6' cord & plug |

OPTIONAL PNEUMATIC FOOT SWITCH

Assembly No. 56304

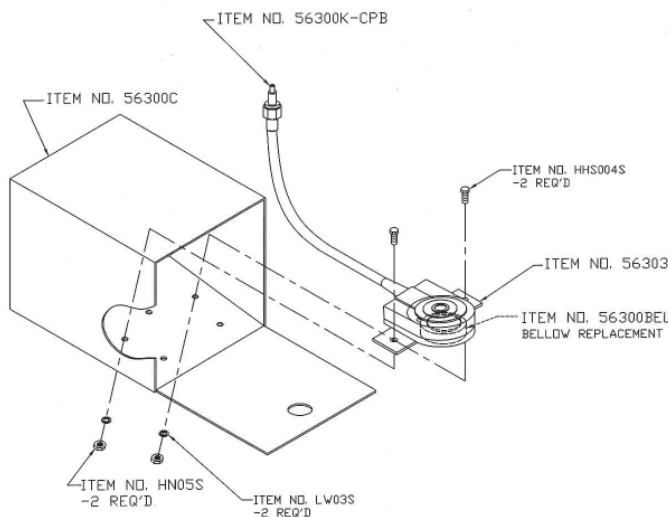

PART NO.	DESCRIPTION
56300BEL	Bellow, Replacement
56300C	Guard only
56300K-CPB	CPB Coupling Metal Body - Male
56303	Foot Switch w/Male Coupling
56304	Foot Switch Assembly w/6' tube, Coupling & Guard
HHS004S	Hex Head Screw, #8 - 32 x 3/8
HN05S	Hex Nut #8-32
LW03S	Lock Washer #8

**ITEMS REQUIRED
FOR 35° TANDEM OPERATION**

**BIRO MANUAL TO BIRO AFMG52
BIRO AFMG52 TO BIRO AFMG48
BIRO AFMG52 TO BIRO AFMG52**

**PLEASE NOTE - THESE ARE DESIGNED
TO WORK ON BIRO EQUIPMENT ONLY**

52 SIZE DISCHARGE HORN ASSEMBLY
Item No. 57143 Includes Clamp Assy.
Item No. 57143-11

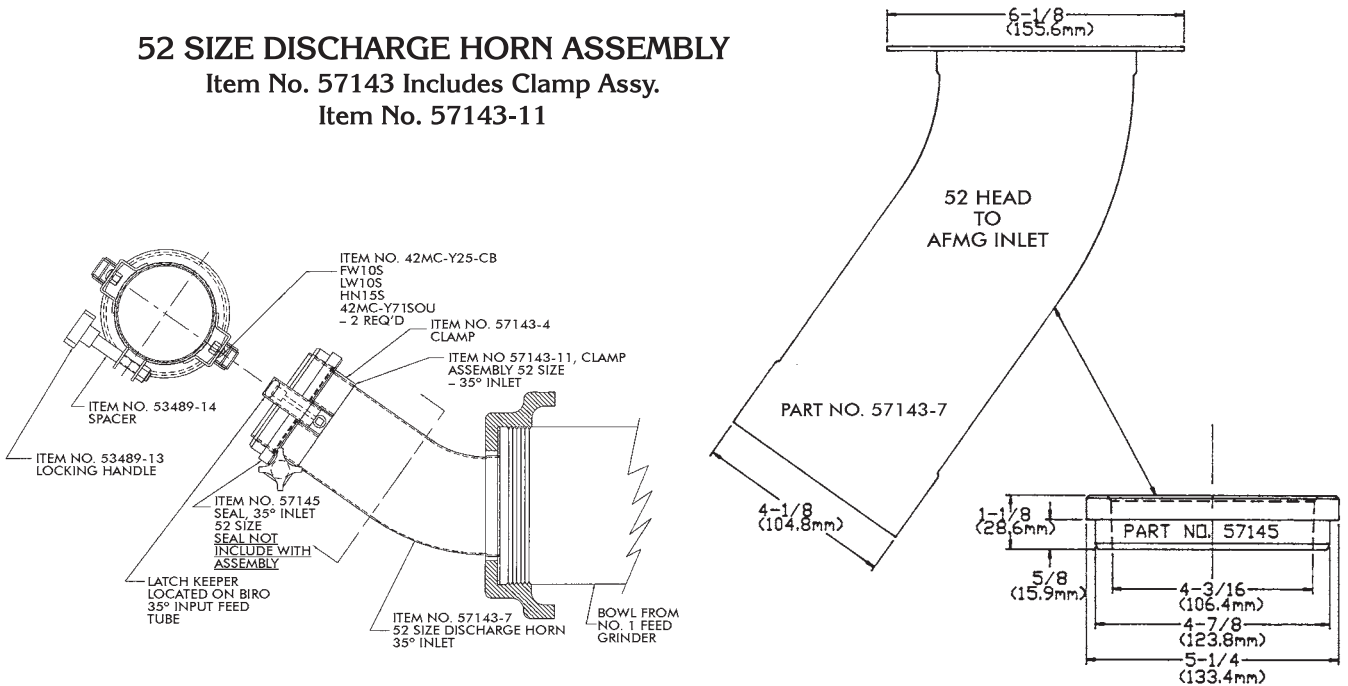

48 SIZE DISCHARGE HORN ASSEMBLY
Item No. 57144 Includes Clamp Assy.
Item No. 57144-11

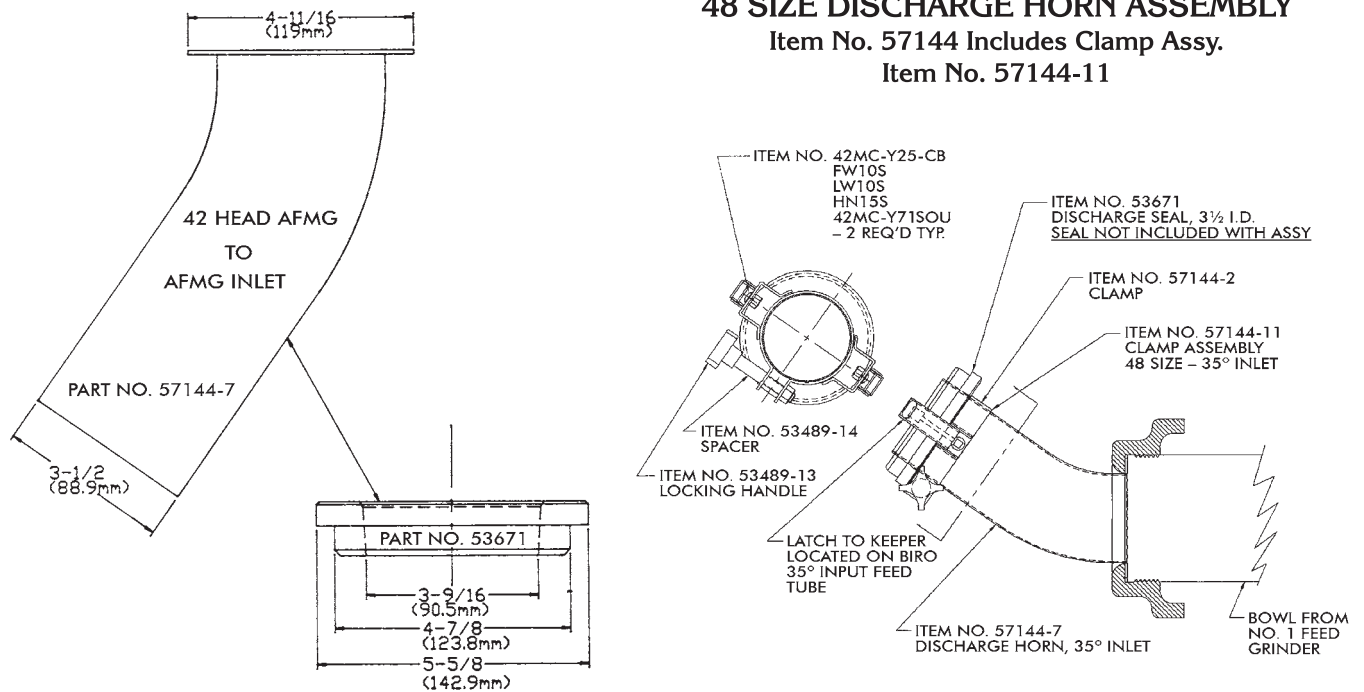

CONNECTION INSTRUCTIONS

TANDEM OPERATIONS AFMG-48 or AFMG-52 INTO AFMG-48 or AFMG-52 Heavy Horsepower Grinder INTO AFMG-48 or AFMG-52

- Step 1.** Remove Side Entrance Seal, Item No. [43040](#); Outer Disc, Item No. [54303](#) and Lock Knobs, Item No. [14688](#) from the inlet tube of the Second Grind Machine. Clean out the tube if necessary.



- Step 2.** Install the Inlet Tube Seal Item No. [53671](#) or [57145](#) into the inlet tube of the Second Grind Machine until fully seated.



- Step 3.** Remove the Ring from the First Grind Machine, Item No. HR42.48 or [HR52](#). Insert the Discharge Horn, Item No. [57144-7](#) or [57143-7](#) into the ring. (DO NOT reinstall the ring on the First Grind Machine at this time.) Slide the Clamp Assembly, Item No. [57144-11](#) or [57143-11](#) onto the Discharge Horn.



- Step 4.** Insert the Discharge Horn with Ring and Clamp Assembly into the Seal, pushing it fully against the inlet tube internal fins. Attach the lock latches to the tabs on the side of the inlet tube and lock down. Tighten the lock knob on the Clamp Assembly.

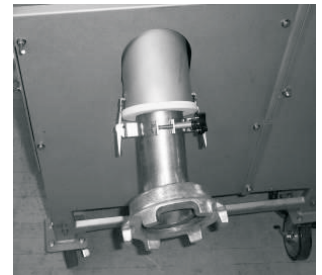

- Step 5.** Move the Discharge Horn of the Second Grind Machine up to the Bowl of the First Grind Machine. With the Auger, Knife and Grinding Plate installed in the First Grind Machine, thread the Ring onto the First Grind Machine Bowl. RING SHOULD BE HAND TIGHTENED ONLY: USE NO TOOLS.



**ITEMS REQUIRED
FOR TANDEM OPERATION**

**BIRO MANUAL TO BIRO AFMG52
BIRO AFMG52 TO BIRO AFMG48
BIRO AFMG52 TO BIRO AFMG52**

**PLEASE NOTE - THESE ARE DESIGNED
TO WORK ON BIRO EQUIPMENT ONLY**

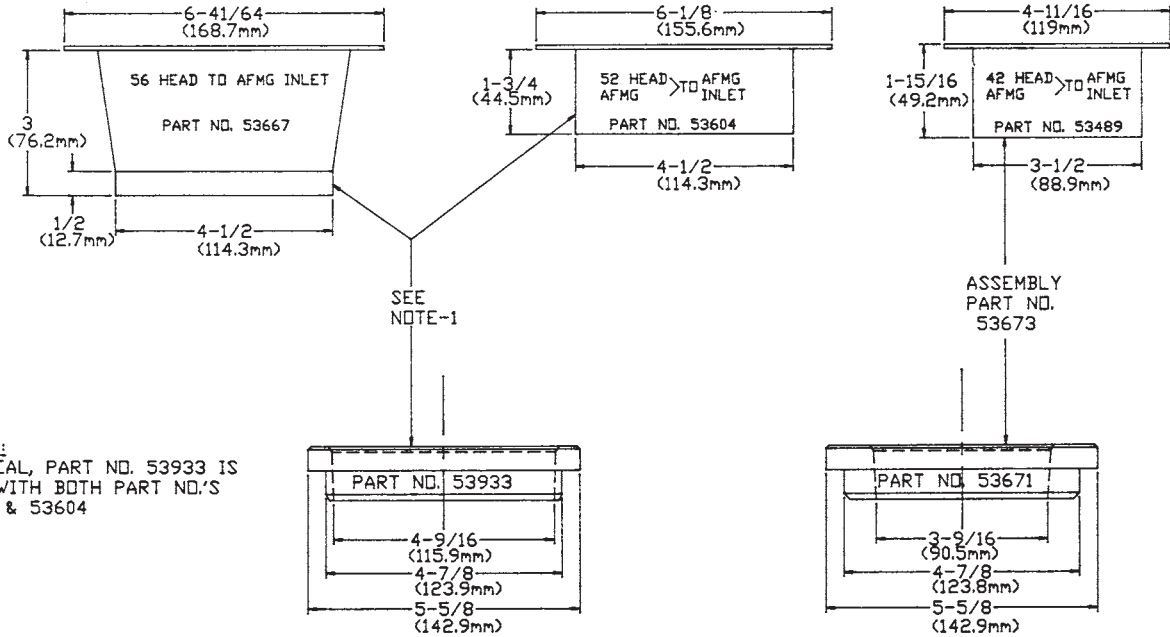

**TANDEM OPERATION
PARTS LIST**

- 272-7-1** 5/16-18 plastic knob, 3 pt.
- 53489** Dscg. Horn 24/42/46/48 to 24/48/52 inlet less seal
- 57044** Connec. brkt. AFMG52 to AFMG48
- 57044** Connec. brkt. AFMG52 to AFMG52
- 53552-1A** Connecting brkt. assem. man/auto
- 53604** Dscg. horn 52 to 24/48/52 inlet
- 53667** Dscg. horn 56 to 24/48/52 inlet
- 53671** Seal only 24/42/46/48 to 24/48/52 inlet
- 53673** Disc. horn 48-52 w/seal
- 53933** Seal only 52/56 to 24/48/52 inlet

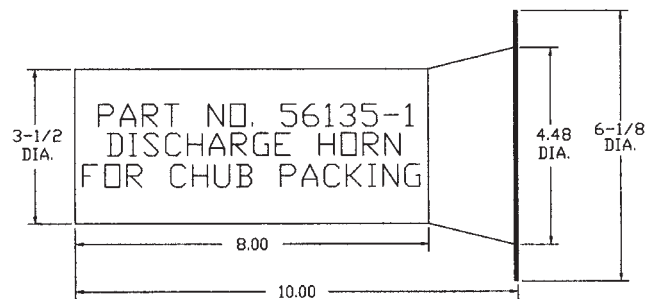

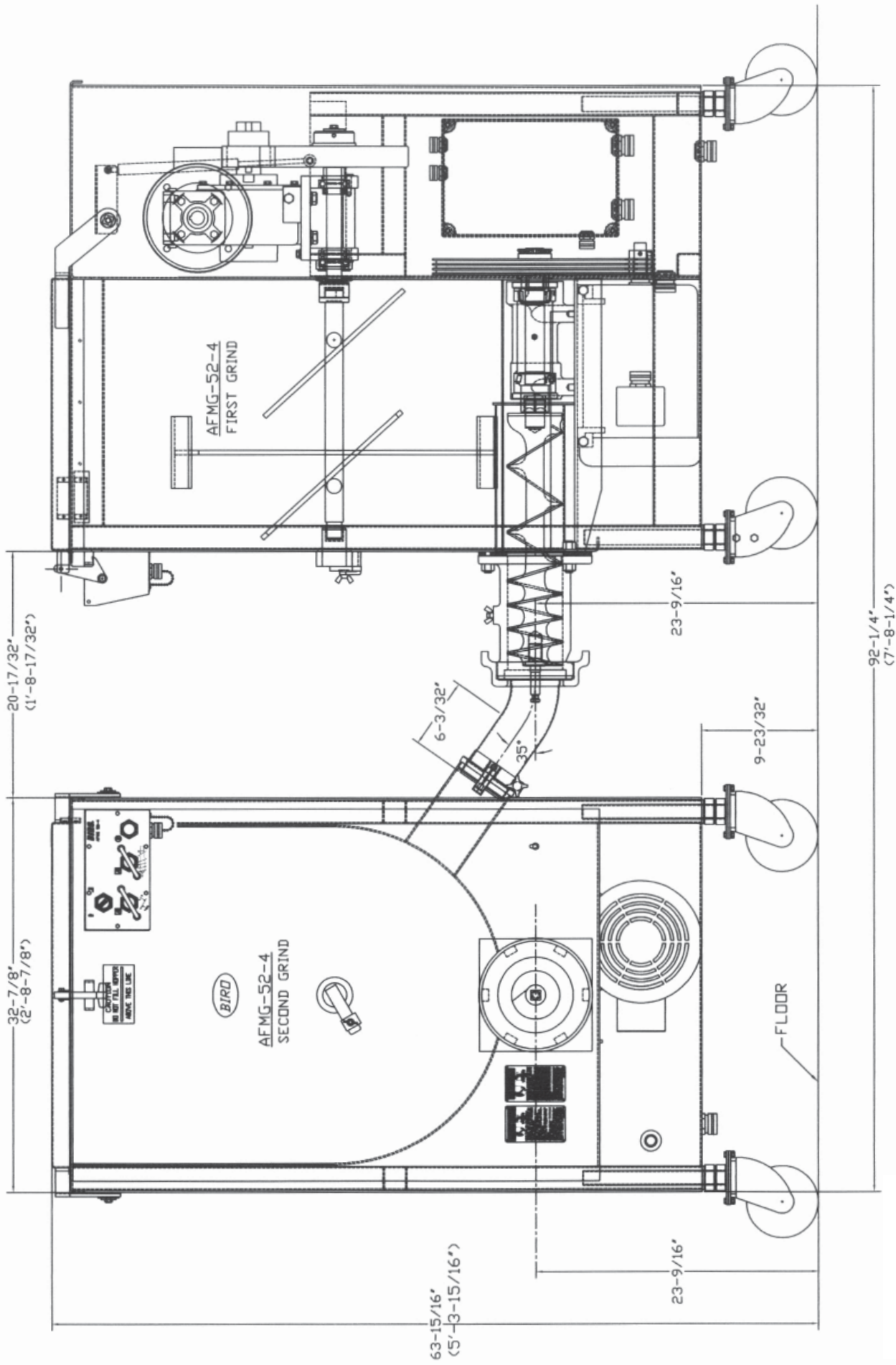

SAFETY LABEL LOCATIONS

**CAUTION
KEEP HANDS OUT OF HOPPER**

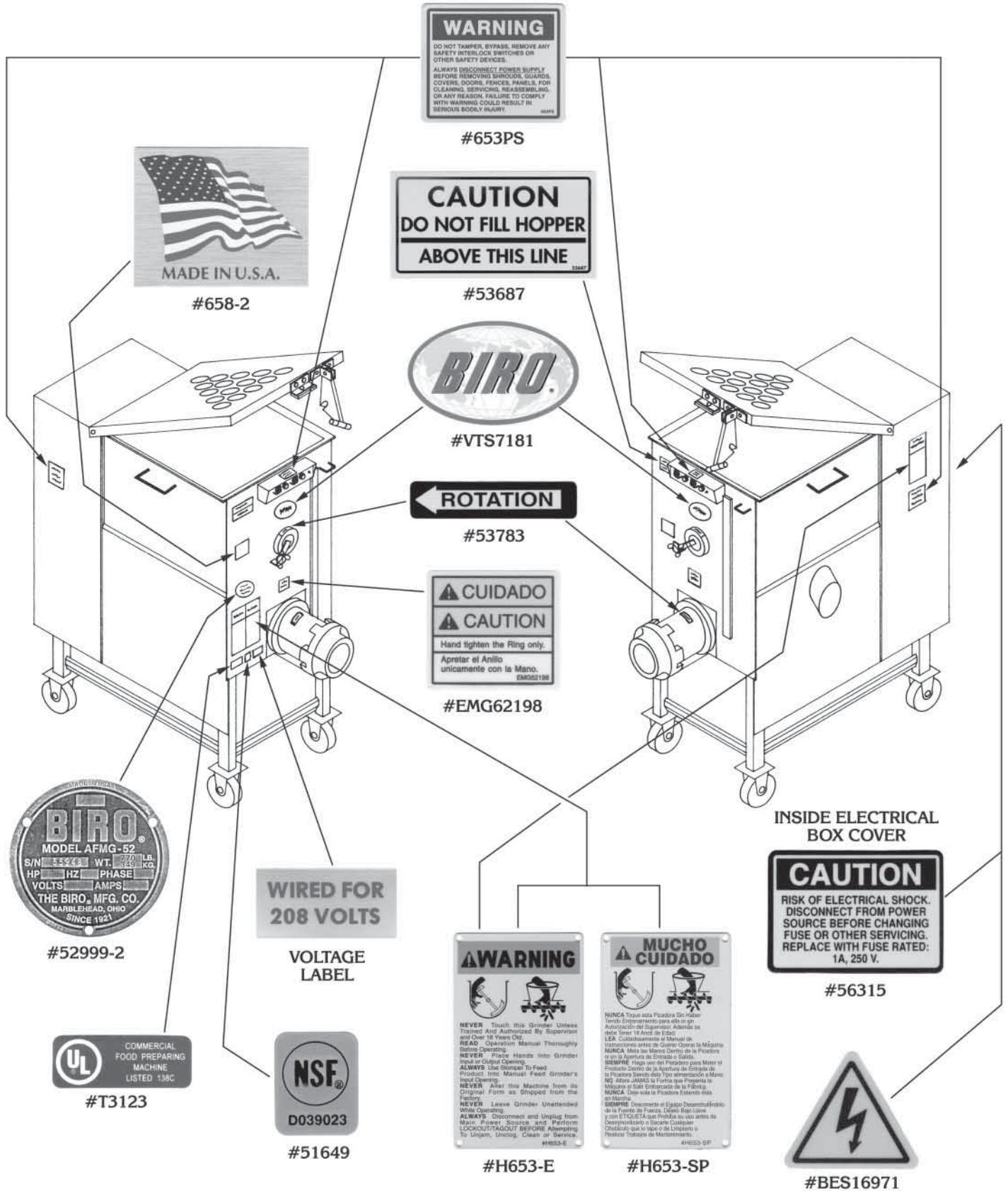

- OPERATOR'S NOTES -

- OPERATOR'S NOTES -

LIMITED WARRANTY

WARRANTY: The Biro Manufacturing Company warrants that the BIRO AFMG-52-4 Mixer Grinder/Chopper will be free from defects in material and workmanship under normal use and with recommended service. BIRO will replace defective parts, which are covered by this limited warranty, provided that the defective parts are authorized for return, shipping charges prepaid, to a designated factory for inspection and/or testing.

DURATION OF WARRANTY: The warranty period for all parts covered by this limited warranty is one (1) year from date of inspection/demonstration as advised on the returned Warranty registration card, or eighteen (18) months from original factory shipping date, whichever date occurs first, except as noted below.

PARTS NOT COVERED BY WARRANTY: The following are **not** covered by this limited warranty: wearable parts in the grinding system such as bowl, ring, worm, drive shaft, and knife drive pin. This limited warranty does not apply to machines sold as used, rebuilt, modified, or altered from the original construction in which the machine was shipped from the factory. Water contaminated electrical systems are not covered under this limited warranty. BIRO is not responsible for electrical connection of equipment, adjustments to the switch controls or any other electrical requirements, which must be performed only by a certified electrician. BIRO is not responsible for service charges or labor required to replace any part covered by this limited warranty or for any damages resulting from misuse, abuse, lack of proper or recommended service.

EXCLUSION OF WARRANTIES AND LIMITATION OF REMEDIES: BIRO gives no warranties other than those expressly stated in this limited warranty. THE IMPLIED WARRANTY OF MERCHANTABILITY, THE IMPLIED WARRANTY OF FITNESS FOR PROCESSING OF FOOD PRODUCTS, AND ALL OTHER IMPLIED WARRANTIES ARE SPECIFICALLY EXCLUDED. BIRO IS NOT LIABLE FOR CONSEQUENTIAL OR INCIDENTAL DAMAGES, EXPENSES, OR LOSSES. THE REMEDIES PROVIDED IN THIS BIRO LIMITED WARRANTY ARE PURCHASER'S SOLE AND EXCLUSIVE REMEDIES AGAINST BIRO.

REGISTRATION CARDS: You must sign, date and complete warranty registration card supplied with each machine. The warranty card must be returned to The Biro Manufacturing Company for proper registration. If no warranty card is returned to BIRO, the warranty period will begin from the date the machine was originally shipped from the factory.

HOW TO GET SERVICE:

1. Contact the entity from whom you purchased the machine; or
2. Consult the yellow pages of the phone directory for the nearest authorized dealer; or
3. Contact BIRO Mfg. Company for the authorized service entity (250 plus worldwide) in your area.

THE BIRO MANUFACTURING COMPANY

1114 Main Street

Marblehead, Ohio 43440-2099

Ph. 419-798-4451

Fax 419-798-9106

E-mail: Service@birosaw.com

Web: <http://www.birosaw.com>