



**B350M**  
**NSF 8-2010**  
**Starting with Serial Number 12309**

**GRAVITY FEED FOOD SLICER**  
**INSTALLATION, USE, MAINTENANCE**  
**& PARTS MANUAL**

REVISED 12-16-15





**DECLARATION OF CONFORMITY**  
**A.B.M. COMPANY S.r.l. Via Rho, 6 – 20020 LAINATE MI – Italia**

**Model: B350M**

s/n: \_\_\_\_\_



Compliant to NSF/ANSI Standard 8: Commercial powered food preparation equipment.

\*EN 60204-1 Machines electrical equipments

\*EN 60335-2-64 Particular requisition for kitchen machines



## **CONTENTS**

<b>FOREWARD</b>	<b>3</b>
SCOPE OF THIS MANUAL	3
GENERAL SAFETY REGULATIONS	3
MANUFACTURER'S WARRANTY AND LIABILITY	4
PLATES-CONFORMITY MARKS	4
ENVIRONMENTAL CONDITIONS OF USE	4
<b>PACKING</b>	<b>5</b>
OPENING THE BOX	5
<b>TECHNICAL DESCRIPTION AND PROPOSED CONDITIONS OF USE</b>	<b>6</b>
GENERAL DESCRIPTION	6
MECHANICAL AND ELECTRICAL SAFETY DEVICES	6
WARNING: RESIDUAL RISKS	6
DIMENSIONS MAIN TECHNICAL DATA	7
SUPPLIED LITERATURE AND ACCESSORIES	8
PRODUCT THAT CAN BE SLICED	8
PRODUCT THAT MUST NOT BE SLICED	8
MAIN COMPONENTS	9
<b>MACHINE COMMISSIONING AND FUNCTION TESTS</b>	<b>10</b>
INSTALLING THE MACHINE	10
ELECTRICAL CONNECTION	10
MANUAL USE	10
<b>USING THE MACHINE</b>	<b>11</b>
LOADING THE PRODUCT ON THE TRAY AND SLICING	11
<b>CLEANING THE MACHINE</b>	<b>13</b>
GENERAL	13
DISASSEMBLING THE SLICER FOR CLEANING	14
<b>DISASSEMBLING THE GUIDE BAR FOR CLEANING</b>	<b>15</b>
<b>CLEANING THE SLICER UNDERNEATH - LIFTING DEVICE</b>	<b>16</b>
<b>CLEANING AND SANITIZING THE BLADE</b>	<b>17</b>
<b>MAINTENANCE</b>	<b>18</b>
GENERAL	18
INSPECTING THE SLICER FOR DAMAGED OR BROKEN PARTS	18
<b>BLADE SHARPENING</b>	<b>19</b>
<b>RECOMMENDED SPARE PARTS</b>	<b>25</b>
<b>SPARE PARTS DIAGRAMS</b>	<b>26</b>

## **FOREWORD**

### **SCOPE OF THIS MANUAL**

This manual contains all the necessary information to install, use and service the gravity slicers for food (please see models in paragraph "Technical Description"). The scope of this document, hereinafter the "manual", is to permit users, and especially end users, to take all the cautions and provisions possible for using this machine safely and for a long period of time.

### **GENERAL SAFETY REGULATIONS**

The slicer must only be used by trained personnel. Furthermore, they must have read this manual carefully.

#### **In particular, please comply to the following instructions**

- Install the machine according to the instructions contained in the "Installation" section.
- Do not use the machine with improvised connections, or provisional or non - insulated cables.
- Check the power cable and gland plate on the machine body regularly, and when necessary have them replaced by a qualified personnel.
- In case of abnormalities, defective operation, incorrect movement, unusual noise, etc stop the machine immediately.
- Before cleaning or servicing, disconnect the machine.
- Always use non-slip gloves during cleaning or maintenance.
- Lay or remove the goods to be sliced on the sliding plate only when the carriage is completely pushed back and the thickness control knob is positioned to 0.
- To move the carriage tray when slicing, use the handle or the product grip handle.
- For extraordinary maintenance (to replace the sharpening stones, the blade, or others) please contact the manufacturer or qualified and duly trained personnel.
- Avoid running the slicer with no product on it.
- The slicer is equipped with a ventilated motor.
- **WARRANTY: 1 YEAR** except for the electrical parts

## MANUFACTURER'S WARRANTY AND LIABILITY

The manufacturer's warranty covering the functioning of the machines and their compliance to the service for which they have been designed depends on the correct application of the instructions contained in this manual.

*The Manufacturer assumes no liability either direct or indirect deriving from:*

- Failure to comply with the instructions contained in this manual;
- Use of the machine by personnel who has not read or fully understood the content of this manual
- Use not complying to the specific norms currently applicable in the country of installation
- Unauthorized modifications and/or repairs
- Use of non original accessories or spare parts.
- Exceptional events.

## PLATES – CONFORMITY MARKS

The machine has been constructed in compliance with NSF/ANSI Standard 8. All the parts used in the machine meet the terms of NSF/ANSI compliance and the NSF mark has been applied to substantiate this compliance.

The plate carrying the Manufacturer's data, the machine data and the NSF mark are applied onto the machine base under the blade guard tie-rod knob.

*In case of wear or damage, the user must replace it.*

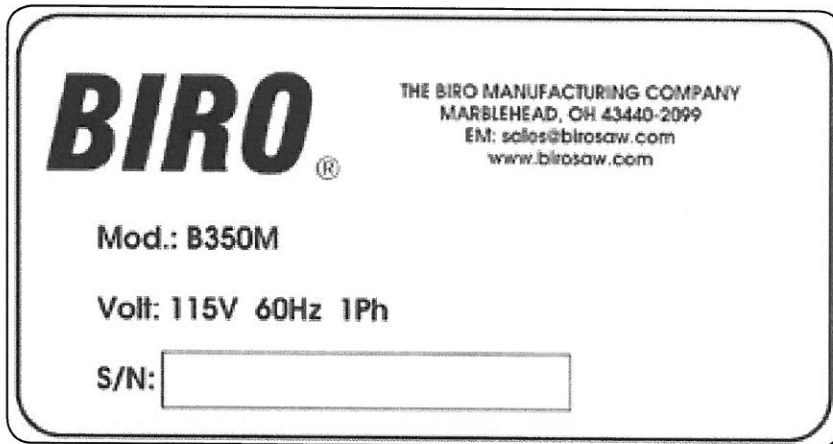

## ENVIRONMENTAL CONDITIONS OF USE

- Temperature from 23 °F to + 104 °F
- Relative humidity max 95%

## PACKING

### OPENING THE BOX

On receipt, check packaging integrity, otherwise inform the forwarding agent or the area agent immediately.

To unpack the machine, proceed as follows:

- Open the box and remove your copy of the manual of use and maintenance, then proceed according to the instructions found in that manual;
- Lift the machine still wrapped in a transparent polyethylene sheet and extract it from the box
- Now check the box contents and make sure it corresponds to what is shown on the external label.

#### WARNING:

The packaging components (cardboard, polyethylene, and others) are classified as normal solid urban waste and can therefore be disposed of without difficulty. In any case, for suitable recycling, we suggest disposing of the products separately (differentiated waste) according to the current norms.

**DO NOT DISCARD ANY PACKAGING MATERIALS IN THE ENVIRONMENT!**



## **TECHNICAL DESCRIPTION AND PROPOSED CONDITIONS OF USE**

### **GENERAL DESCRIPTION**

The machine is essentially made of a base supporting a circular blade mounted in tilted position. This blade is driven by an electrical motor to slice food. The machine is equipped with a carriage holding a product tray and sliding on tracks mounted under the base top, parallel to the blade.

Slice thickness is adjusted by means of a gauge plate mounted in front of the blade. This plate, against which rests the product to be sliced is moved transversally with respect to the blade by a value corresponding to the desired slice thickness. The product is fed to the machine (towards the gauge plate) by gravity.

All the machine components are made of polished and anodized oxidized aluminum alloy, of stainless steel and food grade plastic material.

The blade is driven by an electrical motor, transmission is by means of a longitudinally grooved belt.

The machine is started and stopped by a control button provided with auxiliary circuit preventing accidental restarts after an outage.

Some of the machine models have a user-friendly and safe built-in blade sharpener.

### **MECHANICAL AND ELECTRICAL SAFETY DEVICES**

**The following mechanical safety devices were installed:**

- A series of aluminum and transparent plastic guards on the product carriage.

**The following electrical safety devices were installed:**

- Start/stop button system requiring a voluntary restart of the machine in the case of an outage or interruption of the power supply.
- Safety micro-switch preventing the motor from starting when the blade guard is removed (not on the CE VERSION).



#### **WARNING: RESIDUAL RISKS**

**Not with standing all the possible cautions taken during the design and the construction of the machine, residual risks (cutting) still exist during use or during cleaning or maintenance. Therefore be careful and PAY THE UTMOST ATTENTION to what you are doing.**

**DO NOT use the machine if you are not in perfect psychological and physical conditions. DO NOT ALLOW anyone near the machine when it is in use. ALWAYS wear gloves that can resist cuts or tears when cleaning, lubricating or sharpening the blade.**

**Slice only the products mentioned as sliceable. NEVER try to slice products that have been mentioned as non sliceable.**



## DIMENSIONS MAIN TECHNICAL DATA

### GRAVITY SLICERS

MODEL	B350M		MODEL
motor Kw/hp	0,375 - 0.5		motor Kw/hp
blade diam	14"	350	blade diam
rpm	220		rpm
slice thickness	0 - 1,2"	0 - 30	slice thickness
max cut $\emptyset$	9"1/4	235	max cut mm $\emptyset$
max cut $\square$	11"13/16x6"7/64	300x155	max cut mm $\square$
max cut $\square$	7"7/8x7"7/8	200x200	max cut $\square$
<b>Overall dimensions</b>			<b>Overall dimensions - mm</b>
length	29"3/32	778	length
width	24"	610	width
height	25"	656	height
net weight - Lbs	88 Lbs	40	net weight - Kg
gross weight - Lbs	97 Lbs	44	gross weight - Kg
box dimensions	28"x32"9/32x 24"13/32	710x820x620	box dimensions mm

## **SUPPLIED LITERATURE AND ACCESSORIES**

If not otherwise defined at the moment of order, the machines are supplied together with the following:

- Instructions manual for installation, use and maintenance.
- ETL NSF CSA

## **PRODUCTS THAT CAN BE SLICED**

- All types of cold cuts (raw, cooked, smoked);
- Meat without bone (raw or cooked, at a temperature not less than + 37 °F);
- Cheese cuts (obviously types that can be sliced such as gruyere, mozzarella, etc.).

## **PRODUCTS THAT MUST NOT BE SLICED:**

1. Frozen or deep-frozen food;
2. Food containing bones (meat or fish);
3. Any other non-food product

# MAIN COMPONENTS

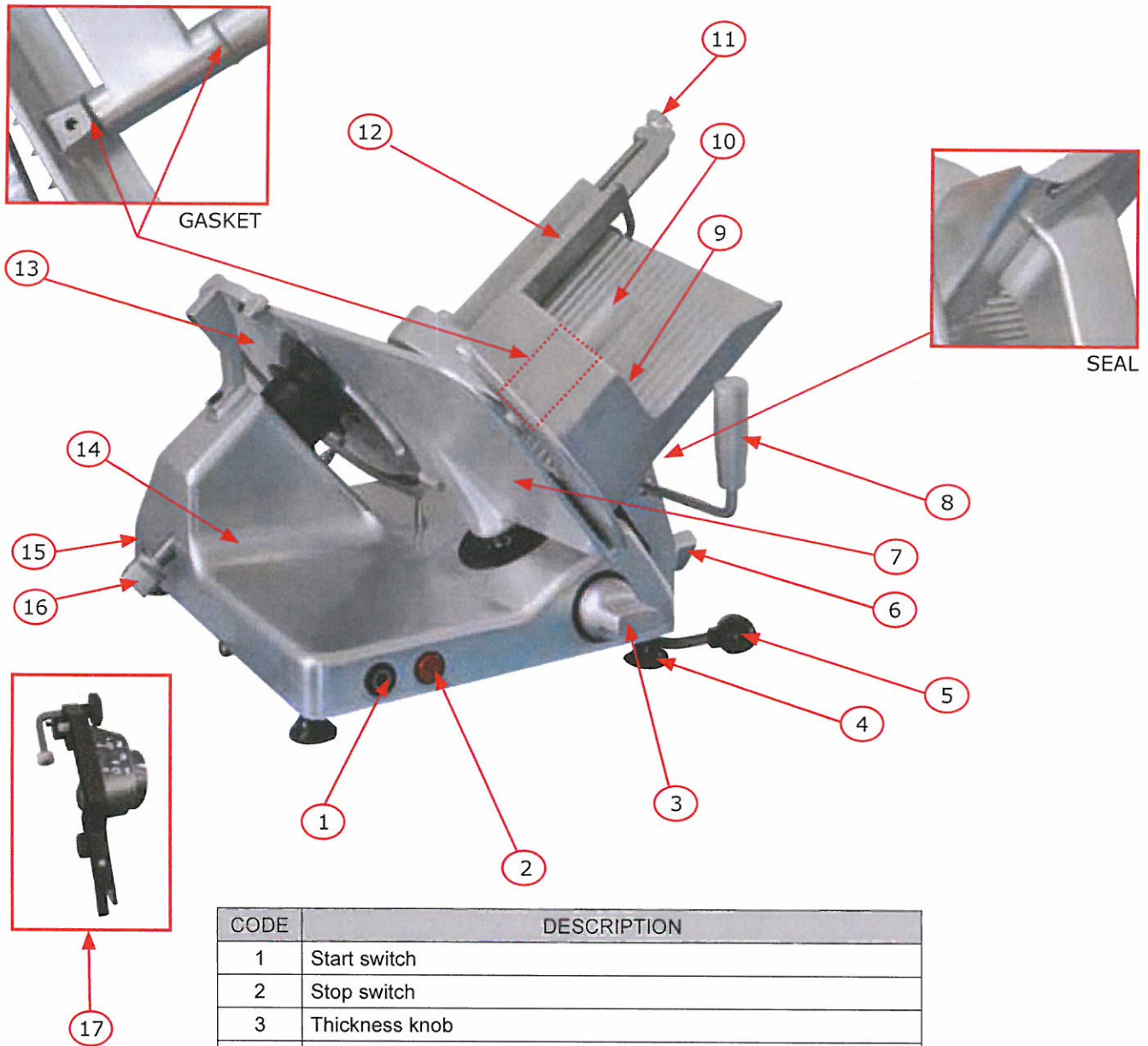

CODE	DESCRIPTION
1	Start switch
2	Stop switch
3	Thickness knob
4	Foot
5	Lifting device lever
6	Knob
7	Gauge plate
8	Carriage handle
9	Carriage tray
10	Pusher handle
11	Removable shaft knob
12	Fence
13	Blade
14	Receiving tray
15	ID Plate
16	Blade guard rod knob
17	Sharpener

## **MACHINE COMMISSIONING AND FUNCTION TESTS**

### **INSTALLING THE MACHINE**

Position the machine on a well leveled, smooth and dry top suitably dimensioned to withstand the machine weight.

### **ELECTRICAL CONNECTION**

Install the machine near a compliant outlet derived from a system meeting the current norms.

**The user is responsible** for ascertaining that the electrical system is suitably dimensioned and functions correctly (supply line, outlet, distribution panel, differential protecting breaker, grounding).

**Before carrying out the connection** ascertain that the mains characteristics correspond to those indicated on the machine plate.

### **MANUAL USE**

#### **START AND STOP BUTTONS**

- Press the green button (1) to start running the blade.
- The light turns on to indicate that the machine works correctly.
- Press the red button to stop the blade (2).

**Slice thickness** can be adjusted by turning the graduated knob (3) anti clockwise.

**Thickness adjustment range:** see paragraph "Technical description and conditions of use".

#### **FUNCTIONING TEST AND BLADE ROTATION DIRECTION**

Start the machine and check whether the light is on; make sure that the blade rotates in the direction indicated by the arrow (anti clockwise if you look at the machine from the blade plate side).

- Ascertain that the carriage and the pusher slide correctly;
- Ascertain that the gauge plate works and adjust thickness to desired value.

**USING THE MACHINE**

**LOADING THE PRODUCT ON THE TRAY AND SLICING**

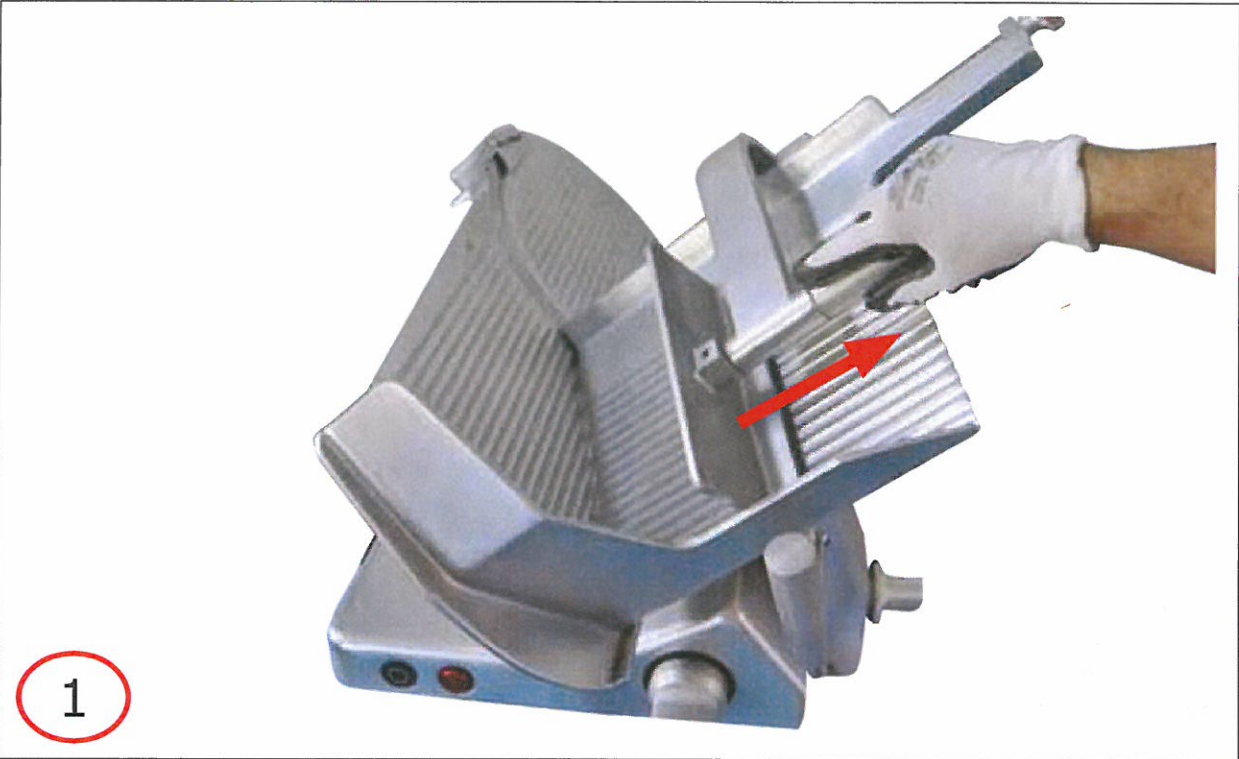

1

Lift the gripper arm

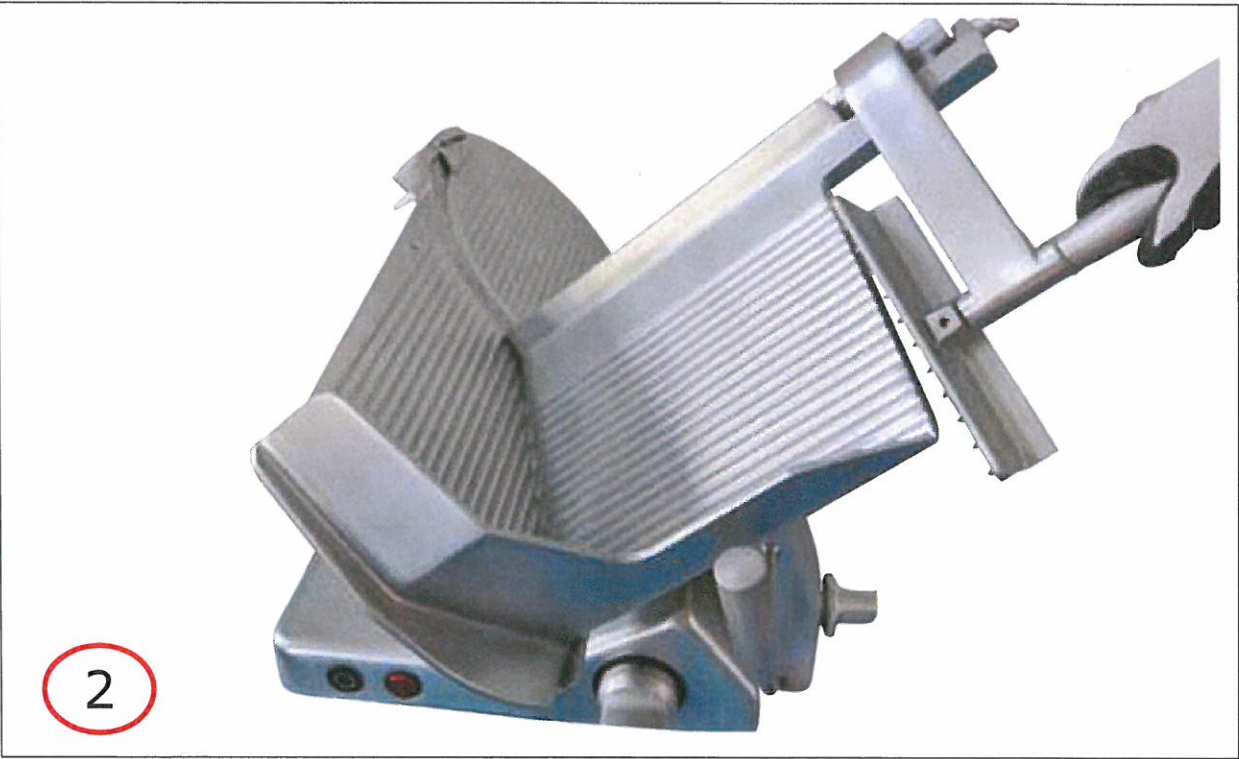

2

Hold on position

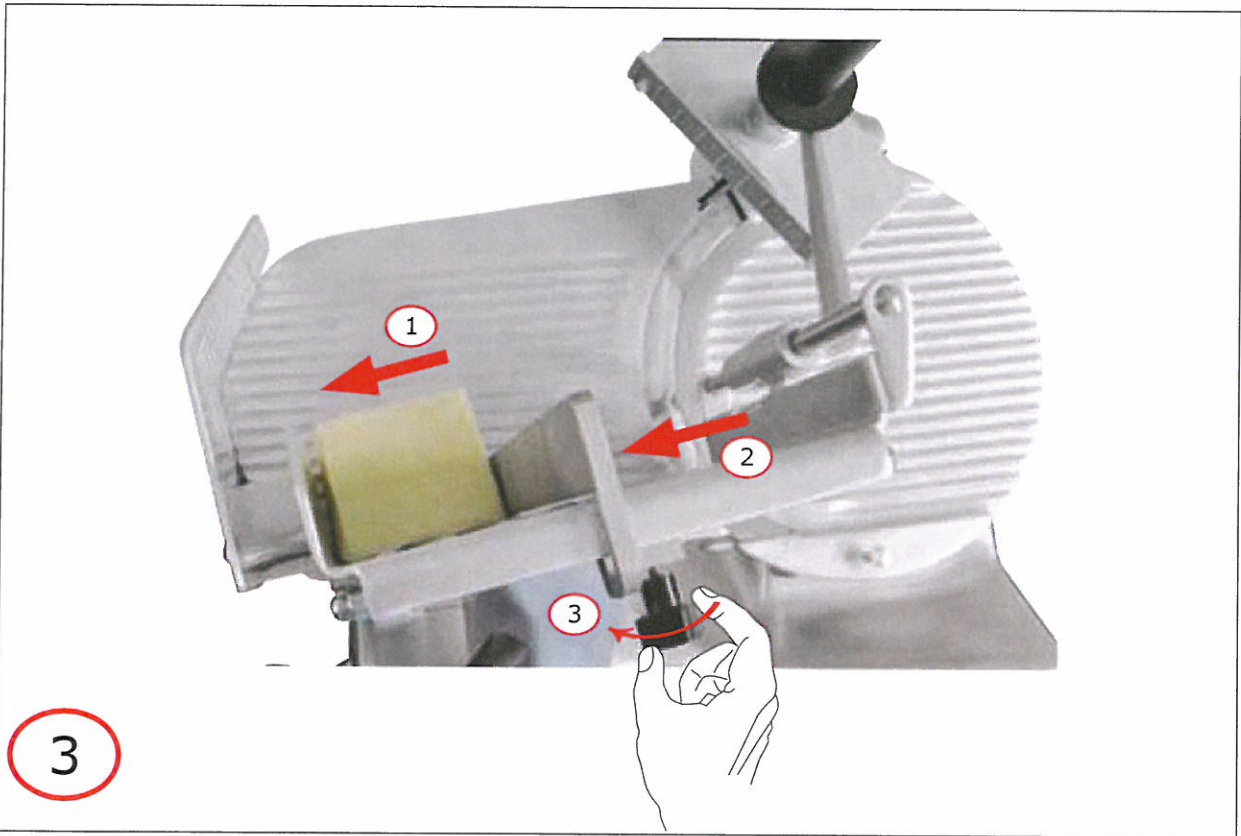

1. Load the product on to the meat platform
2. Slide the fence against the product
3. Lock the fence in place firmly using the locking knob



Select the thickness of the product to be sliced using the portion thickness control knob, then press the start green button.

## CLEANING THE SLICER

### GENERAL

The machine must always be accurately cleaned at least once a day, and more often if necessary.

Always use protective gloves.

### DISASSEMBLING THE SLICER FOR CLEANING (UPSETTING CARRIAGE TRAY)

- Disconnect the plug from the mains;
- Turn the gauge plate to '0';
- Remove the various components as described in the following paragraphs:

To clean the machine body and the blade use only a cloth dampened with water and biodegradable lathery detergent having 7-8 pH and at a temperature not below + 86°F.

**Do not clean the machine by using jets of water or vapor or similar systems.**

#### WARNING:



Use scratch-proof and non-slip gloves to carry out the following operations. Proceed carefully and pay attention to what you are doing. Danger of cutting!

- Stop the machine, rotate the adjustable knob to regulate the gauge plate and position it on 0 (1)
- Return the carriage to the operators side (2)
- Turn the knob (3) anti clockwise, until loose, the carriage will then drop back for cleaning (4).

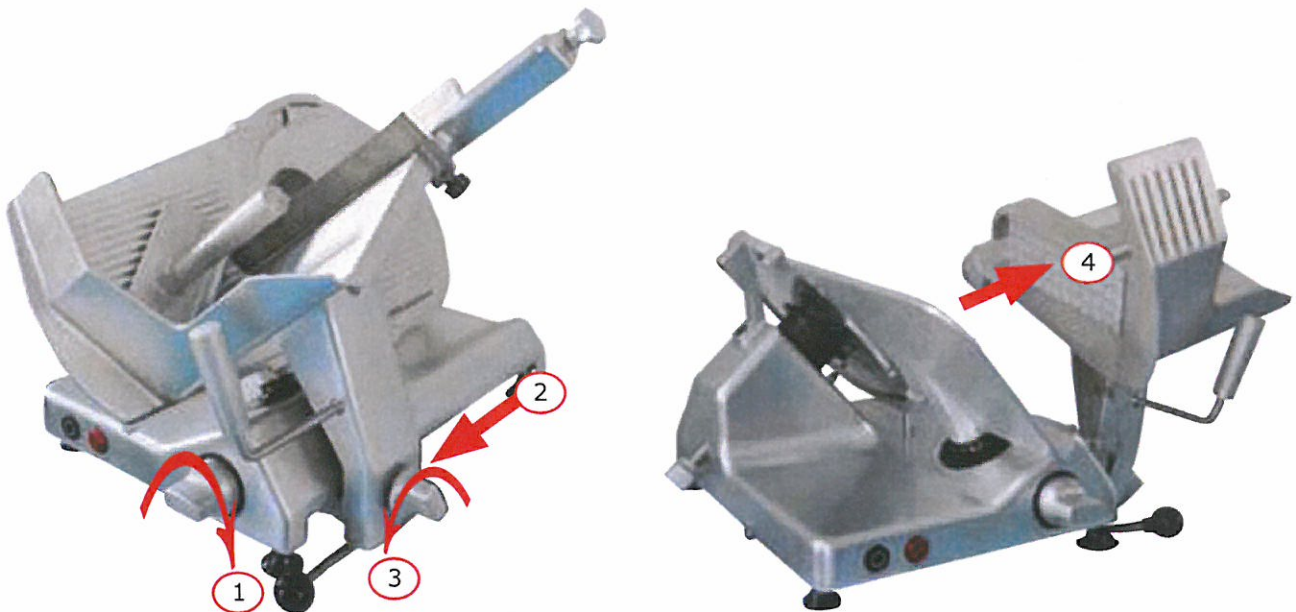

UNSCREW THE BLADEGUARD ROAD (1), than remove the cover blade (2)

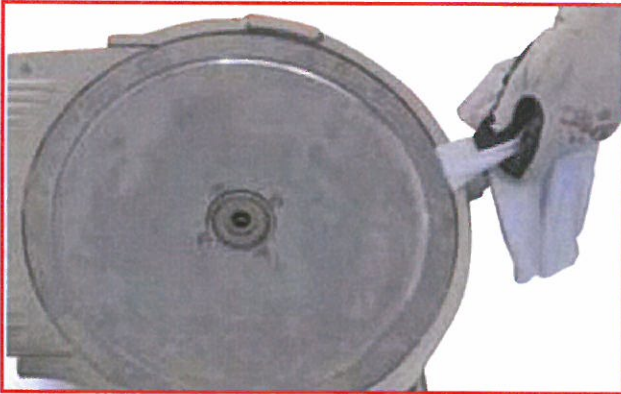

Carefully insert the doth between the knife and the knife ring guard. While holding the cloth between the knife and the ring guard, work it along the entire backside of the knife. Repeat this procedure as necessary . A nylon brush could also be used.

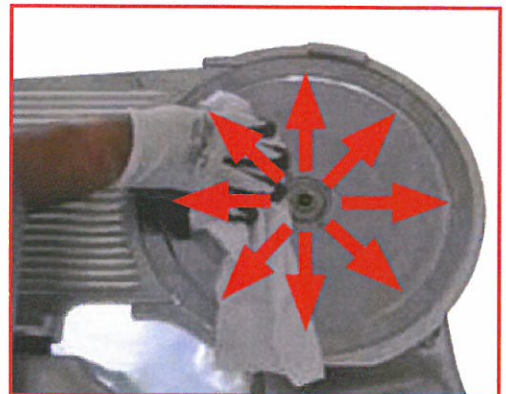

Carefully wash the top and bottom of the knife by wiping from the center of the knife outward.



**REASSEMBLE THE SLICER: PROCEED AS INDICATED FOR THE PREVIOUS OPERATIONS BUT IN REVERSE ORDER**

## DESASSEMBLING THE GUIDE BAR FOR CLEANING

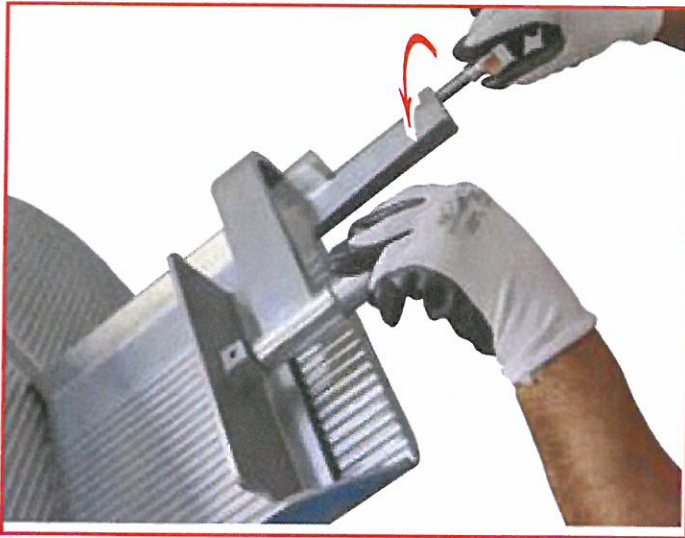

1. Unscrew the knob

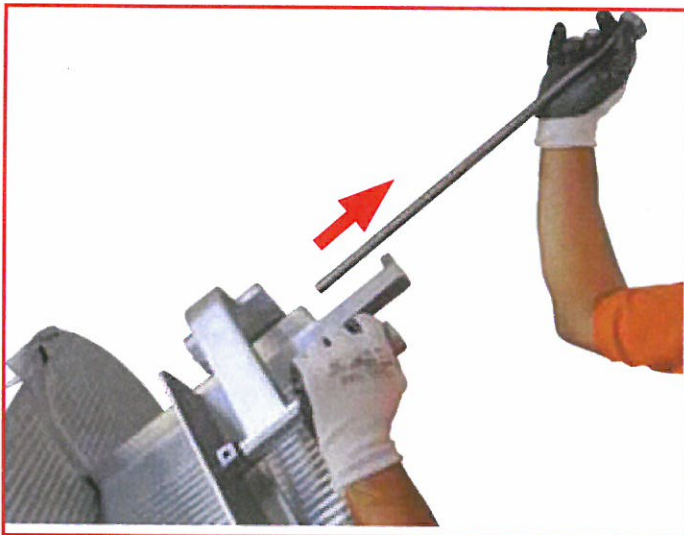

2. Remove the bar

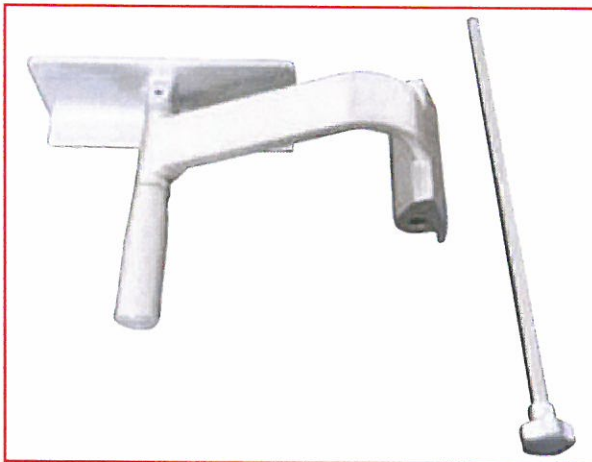

3. Removable parts ready for cleaning



**REASSEMBLE THE SLICER: PROCEED AS INDICATED FOR THE PREVIOUS OPERATIONS BUT IN REVERSE ORDER**

# CLEANING THE SLICER UNDERNEATH - LIFTING DEVICE

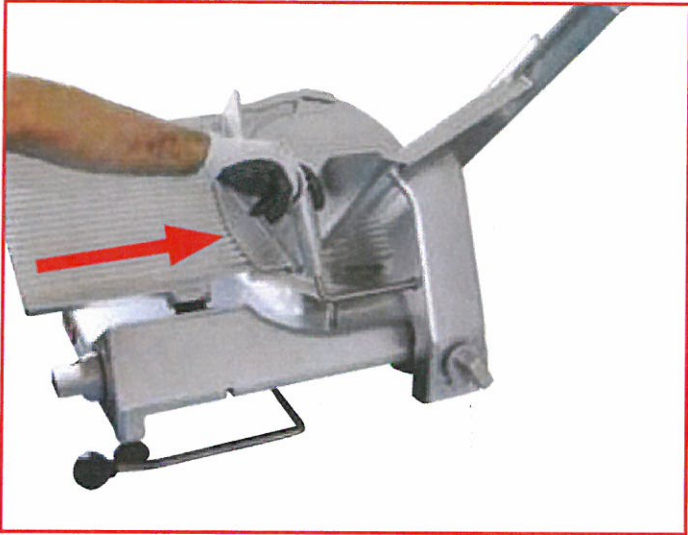

1. Move the carriage forward

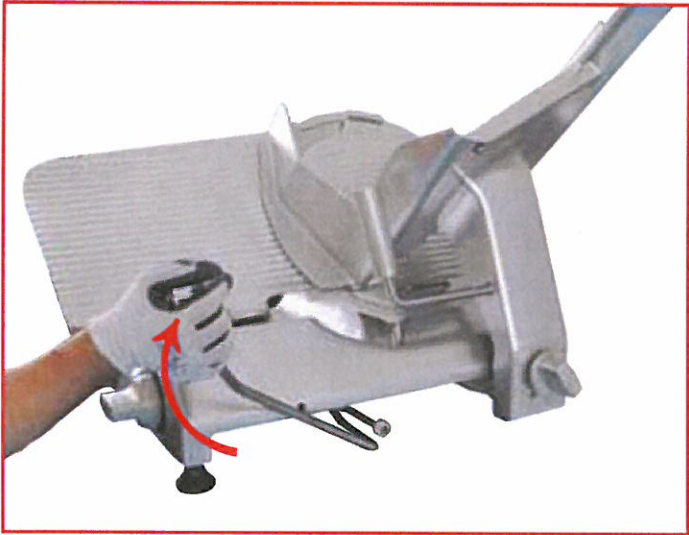

2. Lift the machine by using the proper lever

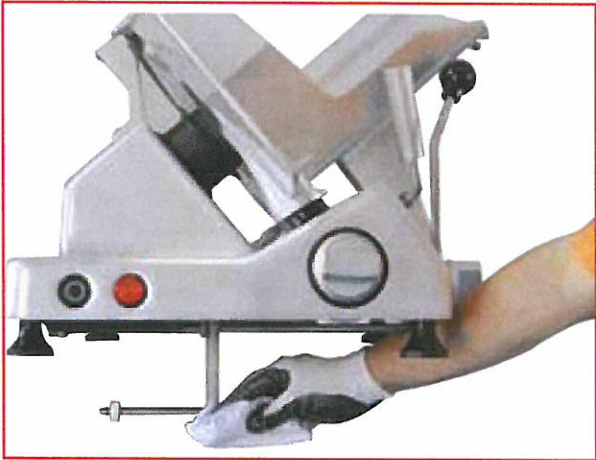

3. Clean underneath

# LIFT DOWN THE MACHINE BY USING THE PROPER LEVER

## CLEANING AND SANITIZING THE BLADE

- Disconnect the plug from the mains;
- Turn the gauge plate to '0';

To clean the machine body and the blade use only a cloth dampened with water and biodegradable lathery detergent having 7-8 pH and at a temperature not below + 86°F.

### WARNING:



Use scratch-proof and non-slip gloves to carry out the following operations. Proceed carefully and pay attention to what you are doing. Danger of cutting!

### SANITIZING

To prevent illness or death caused by the spread of food-borne pathogens, it is important to properly clean and sanitize the entire slicer as any surface of the slicer can become contaminated. It is the responsibility of the slicer owner/operator to follow all guidelines, instructions and laws as established by your local and state health departments and the manufacturers of chemical sanitizers.



Once your slicer makes contact with food product, the entire slicer, including removable parts, must be thoroughly cleaned and sanitized. This process is to be repeated at least every 4 hours using these procedures and information; and comply with additional laws from your state and local health departments.



As with all food contact surfaces, it is extremely important to properly sanitize the entire slicer and to closely follow the instructions on your quaternary sanitizer container to ensure proper sanitation is achieved to kill potentially harmful bacteria.

**IMPORTANT:** If a chemical sanitizer other than chlorine, iodine or quaternary ammonium is used, it shall be applied in accordance with the EPA-registered label use instructions. Excessive amounts of sanitizer and/or use of products not formulated for stainless steel or aluminum may VOID your warranty.

Sanitizer concentration shall comply with section 4-501.114, Manual and Mechanical Warewashing Equipment, Chemical Sanitization - Temperature, pH, Concentration, and Hardness of the FDA Food Code.

Maintain the Owner's Manual supplied with this machine and refer to it often for complete information on cleaning, sanitizing and maintaining the slicer.

**ALWAYS SANITIZE YOUR MACHINE COVERING ALL THE MACHINE WITH THE PROPER PRODUCT.**

## MAINTENANCE GENERAL

The operator is allowed to perform the following maintenance operations:

- Blade sharpening: regularly (intervals and duration obviously depend on the use of the machine, time of use and type of product sliced);
- Lubrication of carriage sliding guides: once a week.
- Lubrication of product grip sliding bar: once a week.
- Checking the power supply wire conditions and the gland plate: from time to time.

**WARNING** 

**Maintenance must always be carried out when the machine is disconnected from the mains.**

**Always make sure that the adjustable knob is in the “O” position**

The following maintenance operations are to be entrusted only to **personnel authorized by the manufacturer:**

- Replacing the blade;
- Replacing the sharpener stones;
- Replacing the motor transmission belt;
- Replacing electrical system components under the machine base;
- Repairing structural parts, repairing the components under the base.

## INSPECTING THE SLICER FOR DAMAGED OR BROKEN PARTS INCLUDING GASKETS & SEALS

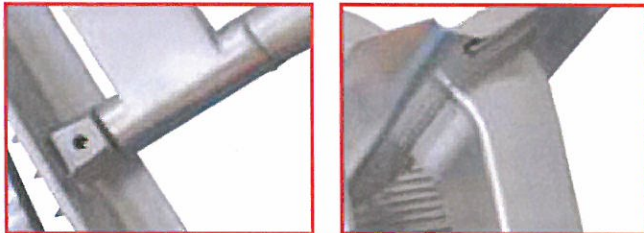

A thorough visual inspection should be made of the entire slicer and its parts.

Biro urges the owner / operator to inspect all components often, including ones that are the detachable for cleaning and sanitizing. This inspection should include: looking for damaged parts, broken seals or gaskets, and areas that may be more difficult to clean and sanitize.

 **WARNING:** IF A SEAL OR GASKET IS FOUND TO NOT PROPERLY SEAL, IS DAMAGED, OR IS MISSING, THE SLICER MUST BE REMOVED FROM SERVICE UNTIL IT IS REPAIRED BY AN AUTHORIZED SERVICER

The recommended interval between inspections shall not exceed six months for components that are detached for cleaning and sanitizing and twelve months for all others.

Authorized saler must provide to inspect the machine every 6 months.

## BLADE SHARPENING - Versions with NOT INTEGRATED sharpener

Before proceeding, carefully clean the machine as explained in the previous paragraphs:



Sharpening can be done only up 0,5 inches of the blade diameter value.

Beyond this value, the **BLADE MUST BE REPLACED ONLY** by personnel **AUTHORIZED BY THE MANUFACTURER.**

To sharpen the blade periodically, proceed as per the following instructions:

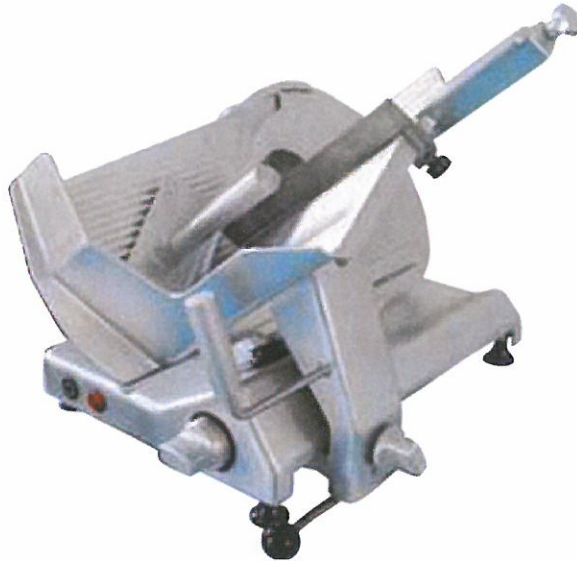

1) Clean the blade

---

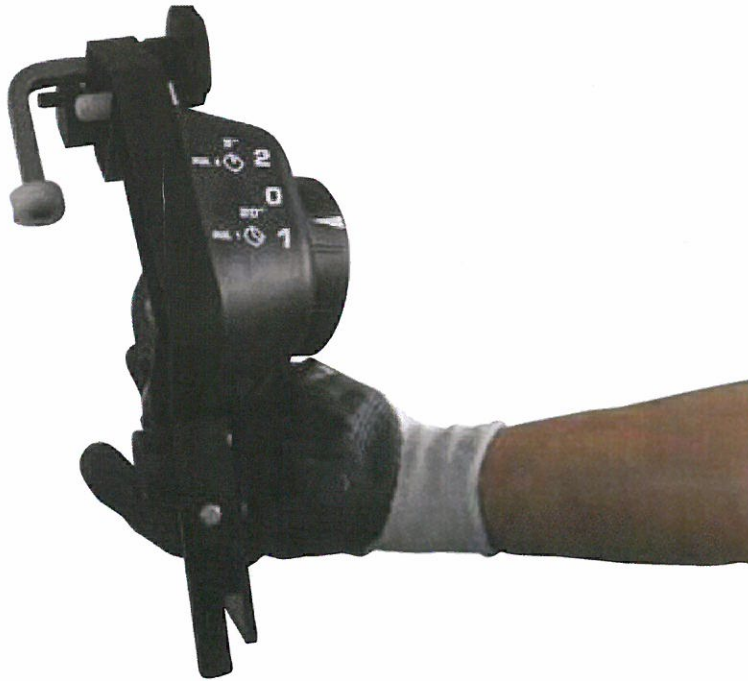

2) Assure the sharpener is at zero position

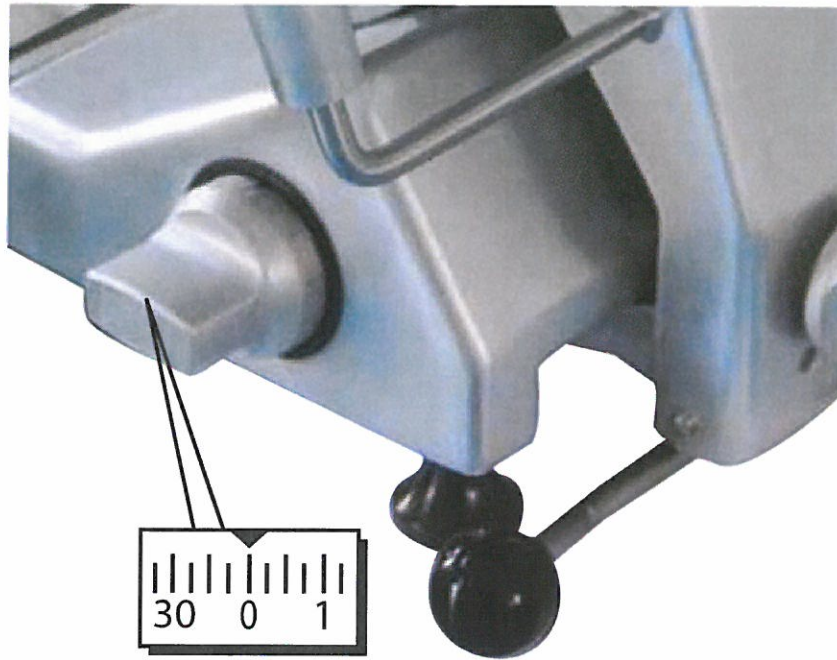

3) Move thickness regulator to the 30 mm position.  
This opens the blade to the desired position ready for positioning the sharpener.

---

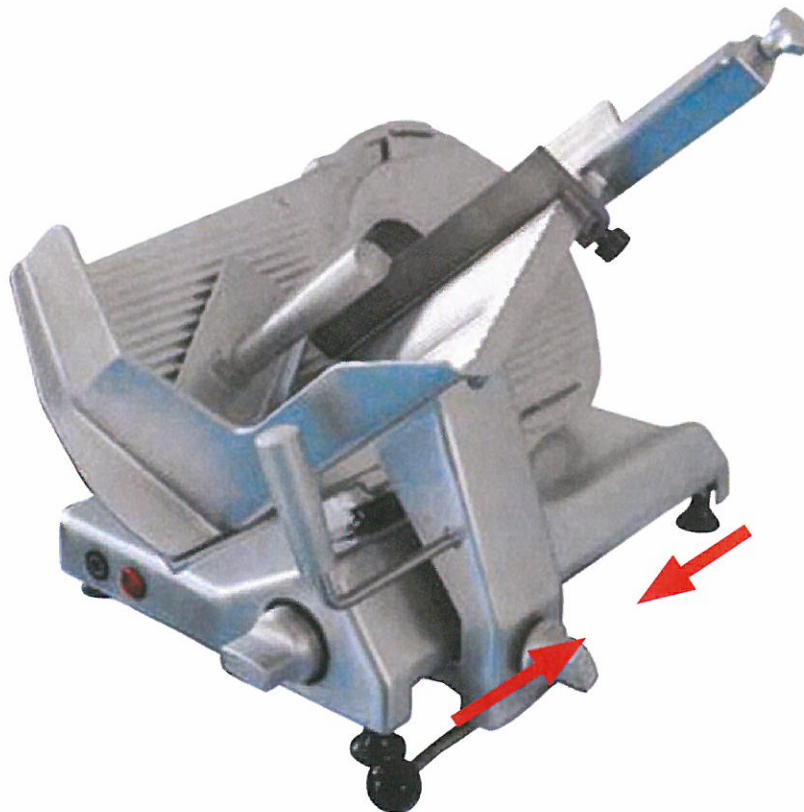

4) Meat plate positioned in the middle.

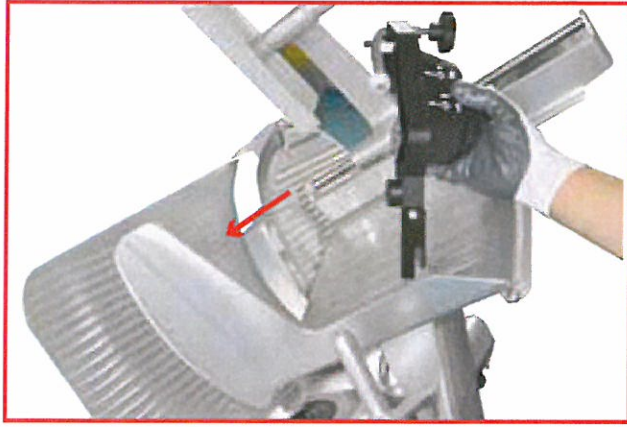

5) The small recess on the gauge plate is for the positioning of the sharpening mechanism  
Verify the correct position

---

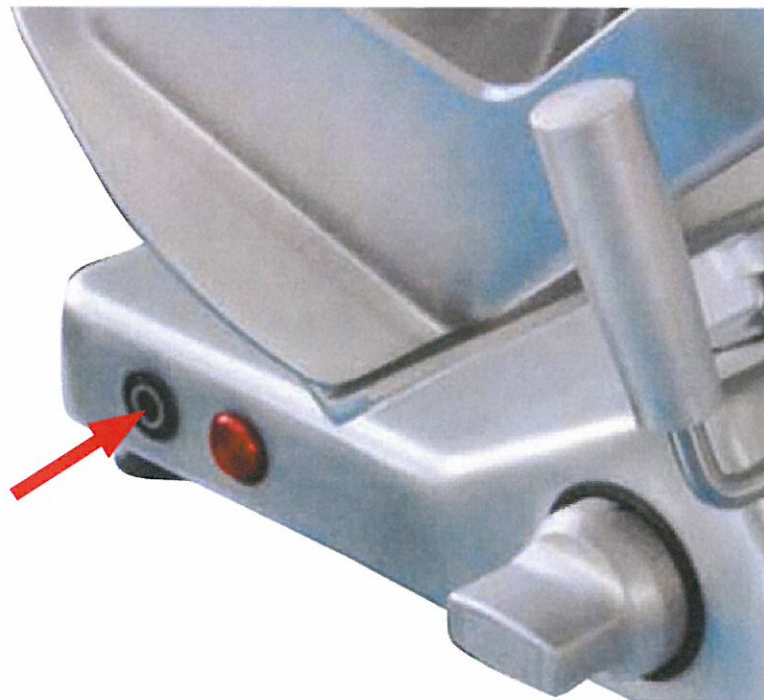

6) Start blade rotating

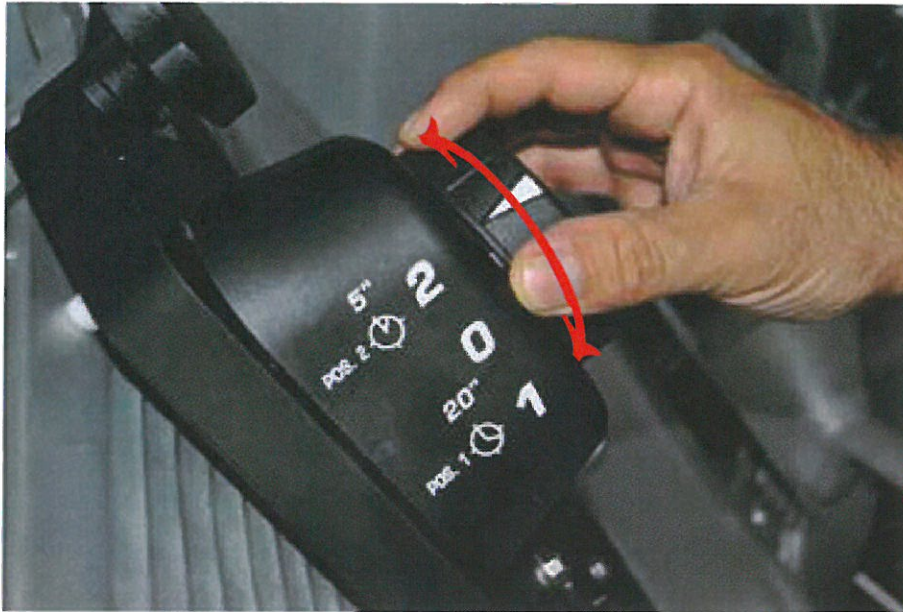

7) Turn dial to position 1. This will sharpen the rear of the blade. Run for 20", turn dial to position 2 for 5". This will take the burr of the front surface of the blade.

---

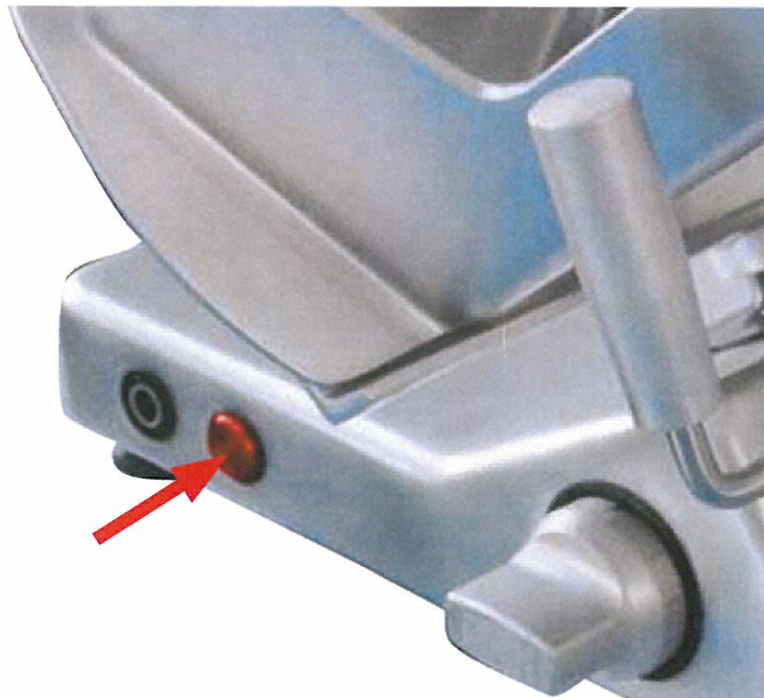

6) Stop the machine.  
Remove the sharpener and **SANITIZE** the blade before using the machine again.

## LUBRICATION

Carriage sliding guides product grip (once a week)

Use only the oil provided, otherwise use white Vaseline oil.  
**DO NOT USE VEGETABLE OILS.**

- Spread a small quantity of oil on the bar and move the assembly 3 or 4 times.
- Clean as required to remove excess of oil.



## DISMANTLING THE SLICER

This machines is made of the following elements:

- Aluminum frame;
- Stainless steel fittings and others;
- Electrical parts and wires;
- Electrical motor;
- Plastic materials, etc.

Whether dismantling is entrusted to third parties or done in-house (in that last case you will have to separate the various materials) please note that disposal of the materials can only be carried out by duly authorized businesses.

In any case, please comply to the current norms of your country.

### WARNING



**In any case, to remove the blade and dispose of it, you must contact the manufacturer or personnel duly authorized by the manufacturer.  
NEVER DISPOSE OF WASTE IN AREAS WHERE ACCESS IS NOT DELIMITED BY BARRIERS AND FORBIDDEN BY WARNING SIGNS AS THIS WASTE REPRESENTS A SERIOUS DANGER, ESPECIALLY FOR CHILDREN AND ANIMALS. ANY RESPONSIBILITY ARISING OUT OF INCORRECT DISPOSAL FALLS ON THE OWNER.**



# BIRO Recommended Spare Parts 2015 EDITION



Z9MAF  
Sharpening stone



GRSTA  
Electrical Box Assembly Mono-Phase 115V-60Hz  
GRSTV10 ONLY B350A  
Electrical Box Assembly Mono-Phase 115V-60Hz

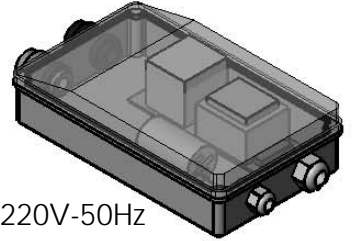

Z9MSB  
Cleaning stone



GRSTS  
Electrical Box Assembly Mono-Phase 220V-50Hz  
GRSTU10 ONLY B350A  
Electrical Box Assembly Mono-Phase 220V-60Hz

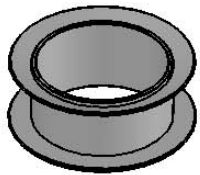

Z9TCA  
Mono phase card 115V-60Hz

Z12AMR ONLY B350A  
Mono phase card 115V-60Hz

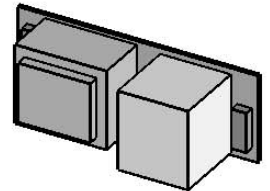

X0090 : B300M  
G111-A : B350M-B350A-B350MV  
Water-ring protection

Z9SCH  
Single phase card 220V-50Hz

B300M :  
M9346 UP S/N 90764  
G7CIN FROM S/N 90765

B350 M :  
G5CIN UP S/N 80415  
G8CIN FROM S/N 80416

B350 A :  
G5CIN UP S/N 10801  
G8CIN FROM S/N 10802

B350 MV :  
G5CIN UP S/N 90732  
G8CIN FROM S/N 90733

Trasmission Belt



Z9PIE  
Foot

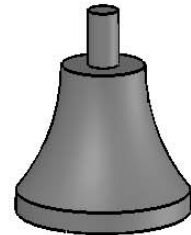

B300 M :  
AF02US

B350M :  
AF04US

B350 A :  
AF01US

B350 MV :  
AF03US

Sharpener

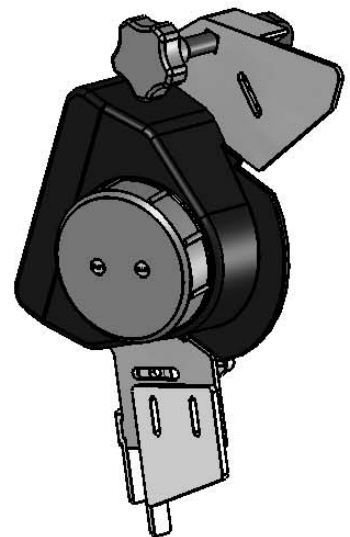

MODEL 300 :  
G9310

MODEL 350 STND :  
Z5L4G

MODEL 350 3rd GEN. :  
Z5L3G

Blade

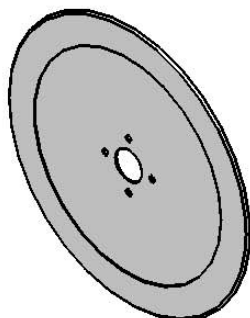



BIRO  
B 350 M  
MANUAL SLICER



STANDARD 8 - 2010

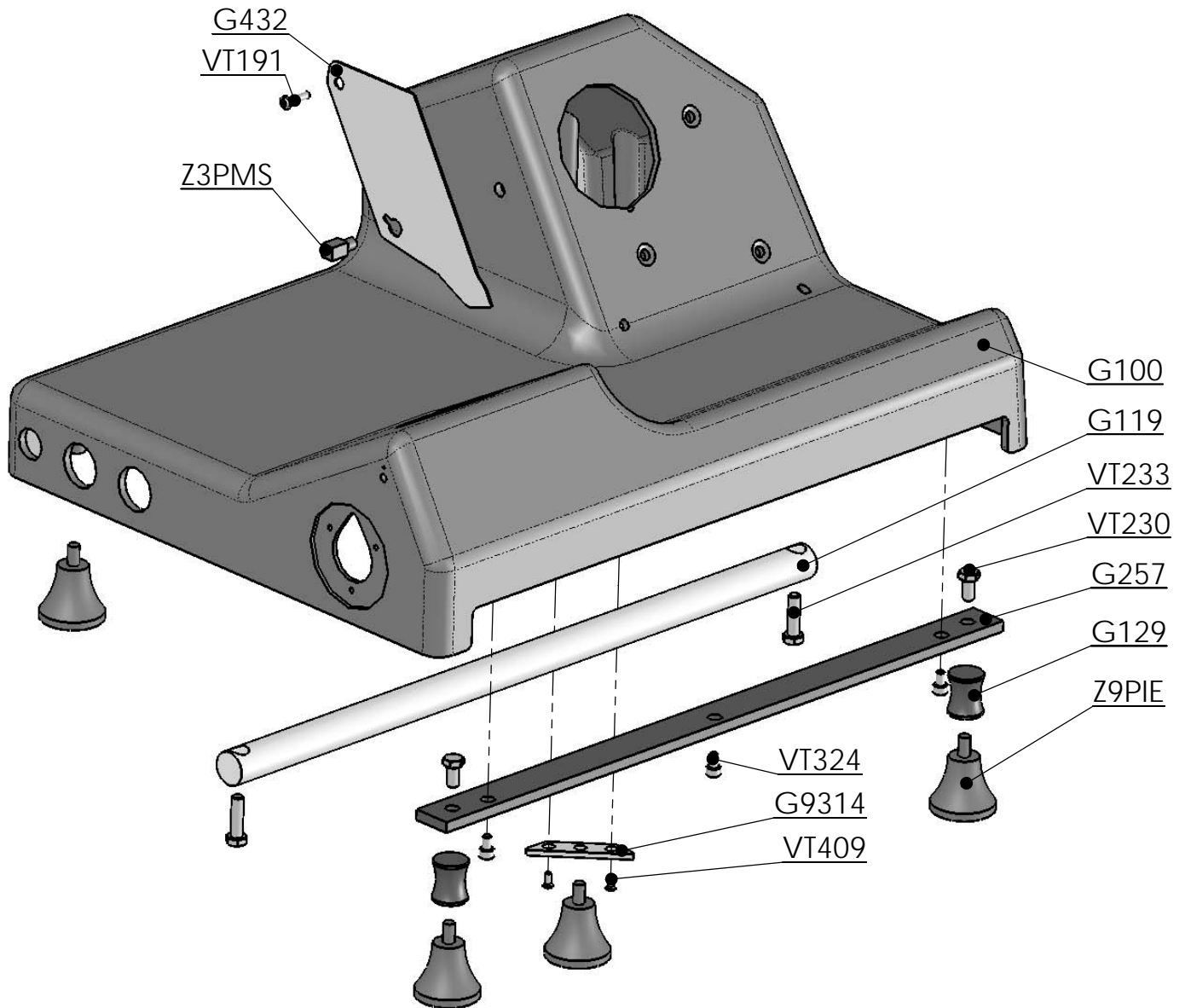

CODE	DESCRIPTION
G100	FRAME
G119	SLIDE ROD - 25 x 578
G129	SS FOOT SPACER 25 x 30 M8
G257	SS BAR - TRANSPORT ROLLER
G432	SLICE SEPARATOR
G9314	FOOT PLATE
VT 191	HEX HEAD SCREW M5-0.8x8 SS
VT 230	HEX HEAD SCREW M8-1.25x16 SS
VT 233	HEX HEAD SCREW M8-1.25x30 SS
VT 324	HEX SOCKET HEAD SCREW M6-1.0x10 SS
VT 409	CYLINDRICAL FLAT HEAD FOR SCREW DRIVER M5-0.8x12 SS
Z3PMS	SCRAPER KNOB
Z9PIE	FOOT



BIRO  
B 350 M  
MANUAL SLICER



VERSION TILL S.N. 15111

STANDARD 8 - 2010

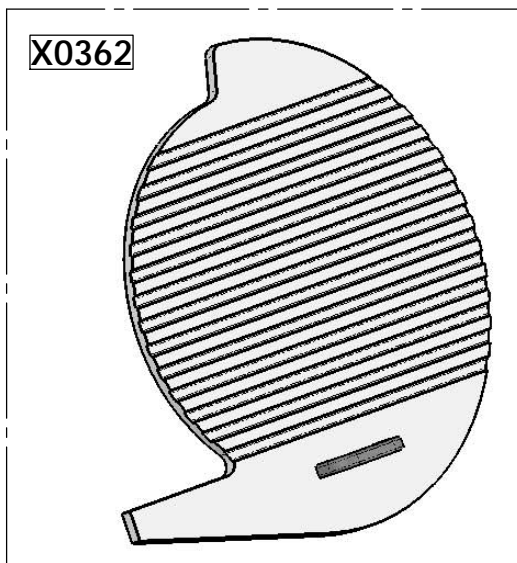
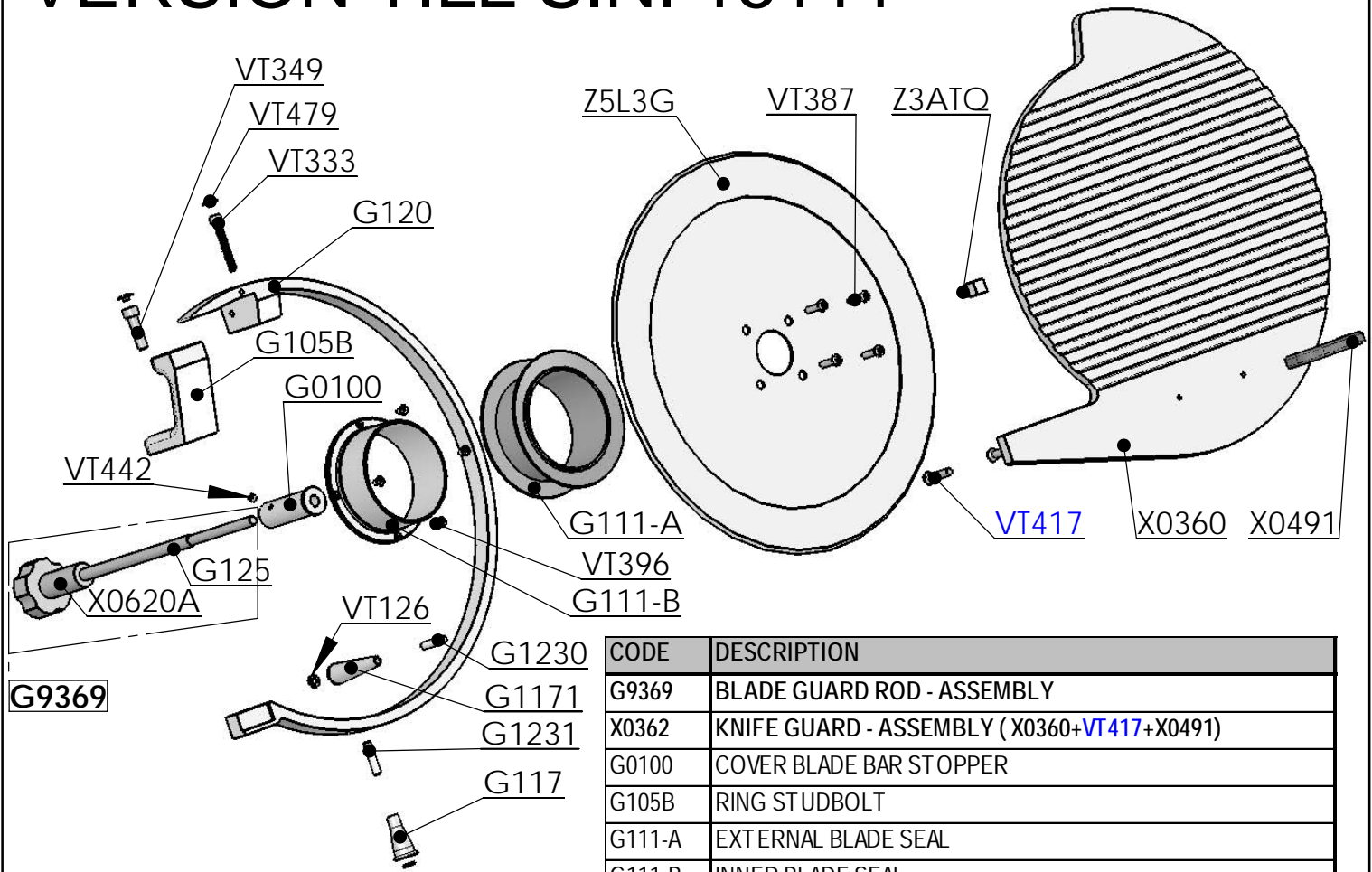

CODE	DESCRIPTION
G9369	BLADE GUARD ROD - ASSEMBLY
X0362	KNIFE GUARD - ASSEMBLY ( X0360+VT417+X0491)
G0100	COVER BLADE BAR STOPPER
G105B	RING STUDBOLT
G111-A	EXTERNAL BLADE SEAL
G111-B	INNER BLADE SEAL
G117	SPACER-PROTECTION RING L 37MM
G1171	SPACER-PROTECTION RING L 58MM
G120	KNIFE RING
G1230	THREADED ROD M6-1.0 x 85 mm
G1231	THREADED ROD M6-1.0 x 65 mm
G125	BLADE GUARD ROD
VT086	HEX NUT M6-1.0 SS
VT104	ACORN HEX CAP M6-1.0 SS
VT126	FLAT WASHER M6 SS
VT333	HEX SOCKET HEAD SCREW M6-1.0x45 SS
VT349	HEX SOCKET HEAD SCREW M8-1.25x16 SS
VT387	SLOTTED OVAL COUNTERSUNK HEAD M5-0.8x16 SS
VT396	PHILLIPS FLAT COUNTERSUNK HEAD M4-0.7x8 SS
VT417	CYLINDRICAL FLAT HEAD FOR SCREW DRIVER M4-0.7x10 SS
VT442	HEX SOCKET SET SCREW CUP POINT M6-1.0x6 SS
VT479	PROTECTIVE CAP d.15.5-4.1x3
X0360	KNIFE GUARD
X0491	HANDLE - COVER BLADE
X0620A	ALU KNOB - BLADE GUARD ROD
Z3ATQ	KNIFE GUARD LOCKING SCREW
Z5L3G	KNIFE 350 mm 14" (3RD GEN.)



BIRO  
B 350 M  
MANUAL SLICER



VERSION FROM S.N. 15112 STANDARD 8 - 2010

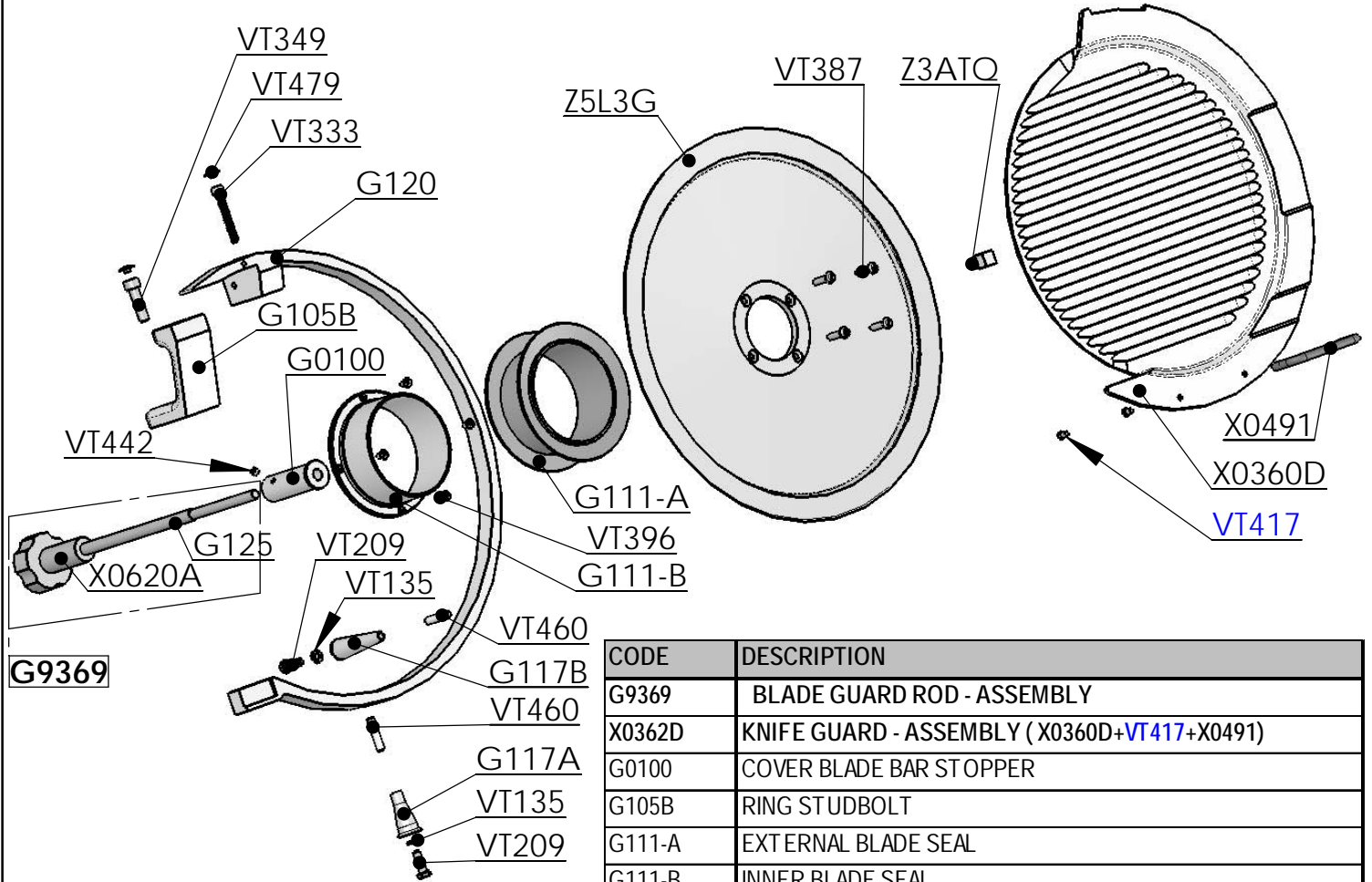

**G9369**

CODE	DESCRIPTION
G9369	BLADE GUARD ROD - ASSEMBLY
X0362D	KNIFE GUARD - ASSEMBLY ( X0360D+VT417+X0491)
G0100	COVER BLADE BAR STOPPER
G105B	RING STUDBOLT
G111-A	EXTERNAL BLADE SEAL
G111-B	INNER BLADE SEAL
G117A	SPACER-PROTECTION RING L 38MM
G117B	SPACER-PROTECTION RING L 58MM
G120	KNIFE RING
G125	BLADE GUARD ROD
VT086	HEX NUT M6-1.0 SS
VT135	FLAT WASHER LG OD d.6-18od SS
VT209	HEX HEAD SCREW M6-1.0x20 SS
VT333	HEX SOCKET HEAD SCREW M6-1.0x45 SS
VT349	HEX SOCKET HEAD SCREW M8-1.25x16 SS
VT387	SLOTTED OVAL COUNTERSUNK HEAD M5-0.8x16 SS
VT396	PHILLIPS FLAT COUNTERSUNK HEAD M4-0.7x8 SS
VT417	CYLINDRICAL FLAT HEAD FOR SCREW DRIVER M4-0.7x10 SS
VT442	HEX SOCKET SET SCREW CUP POINT M6-1.0x6 SS
VT460	HEX SOCKET SET SCREW FLAT POINT M6-1.0x20 SS
VT479	PROTECTIVE CAP d.15.5-4.1x3
X0360D	KNIFE GUARD
X0491	HANDLE - COVER BLADE
X0620A	ALU KNOB - BLADE GUARD ROD
Z3ATQ	KNIFE GUARD LOCKING SCREW
Z5L3G	KNIFE 350 mm 14" (3RD GEN.)

**X0362D**

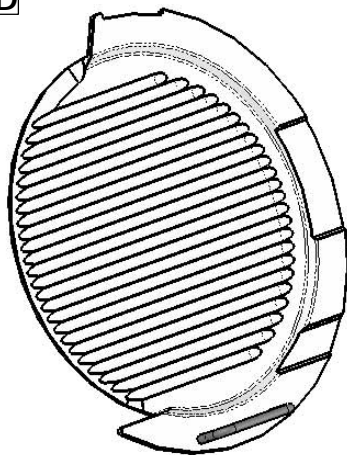

**STANDARD 8 - 2010**

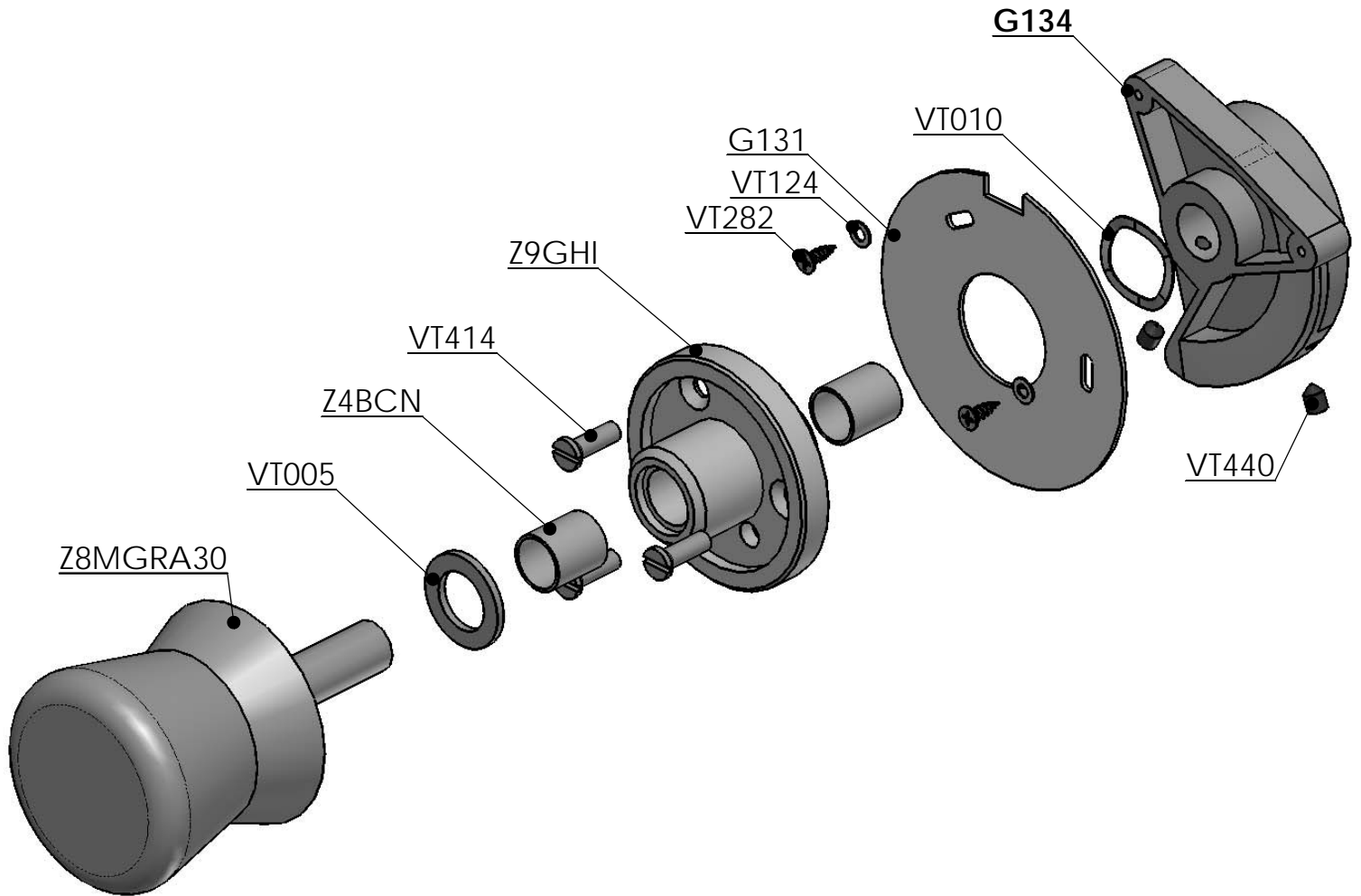

CODE	DESCRIPTION
G134	CAM INDEXING 30mm + VT440
G131	SPACER CAM
VT005	SPACER RING d. 18-25x1 SS
VT010	SPRING WASCHER d. d.18.5-32x0.3 BLACK
VT124	FLAT WASHER M4 SS
VT282	HEX HEAD TAPPING SCREW 4,8x13 ISO 1479-DIN 7976 C
VT414	CYLINDRICAL FLAT HEAD FOR SCREW DRIVER M5-0.8x8 SS
VT440	HEX SOCKET SET SCREW CUP POINT M6-1.0x16 SS
Z4BCN	BUSHING 18 - 20 - 15
Z8MGRA30	ADJUSTABLE ALU KNOB INDEXING 0 - 30mm
Z9GHI	KNOB SPACER 76,6

STANDARD 8 - 2010

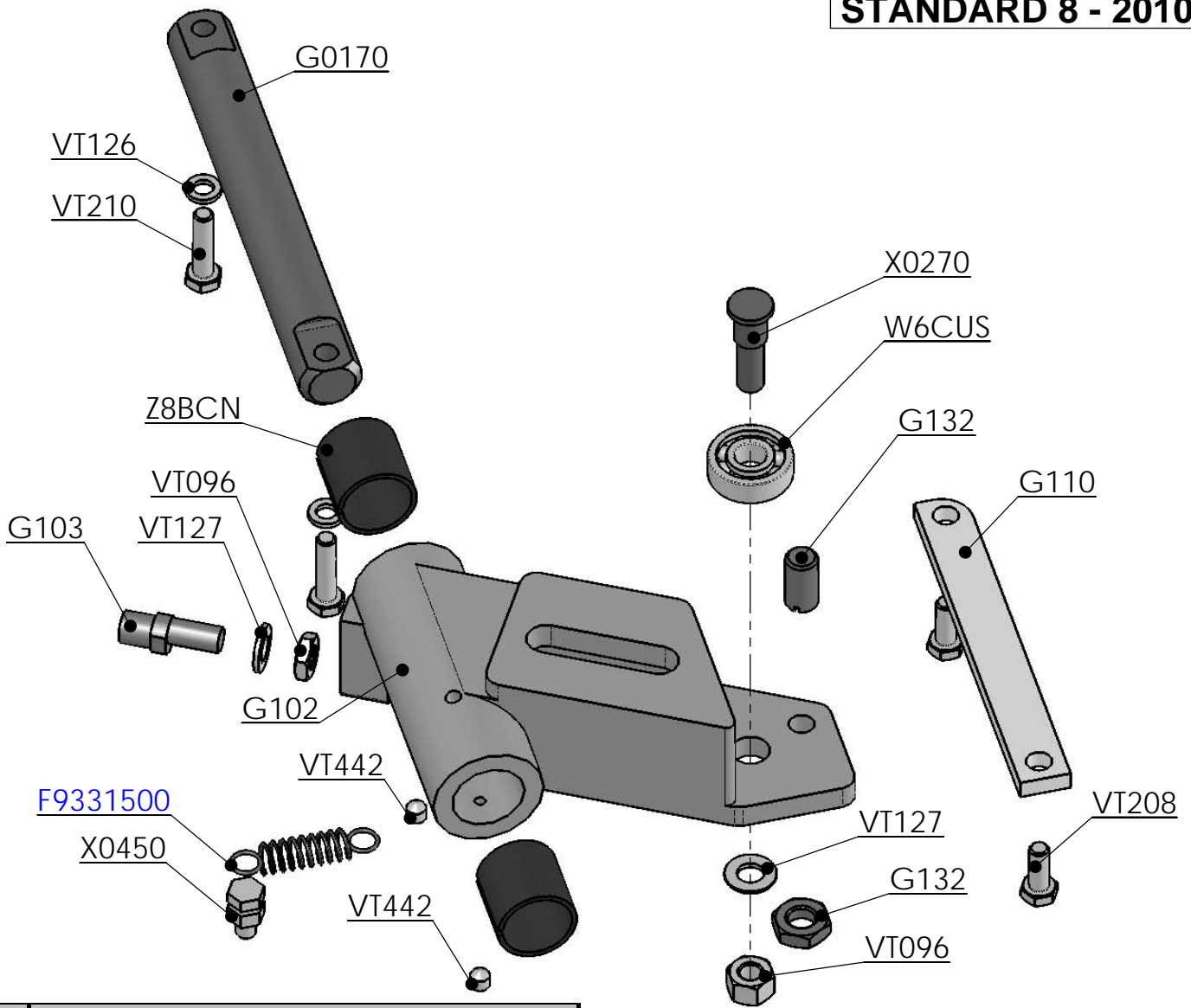

CODE	DESCRIPTION
G9361A	SLIDE INDEX ASSEMBLY (G102+Z8BCN+VT442)
F9331500	SPRING d 10 L 55
G0170	ROD - INDEX SLIDE
G102	SLIDE - INDEX MECHANISM
G103	PIN - INDEX CAM D8
G110	ROD - INDEX ANTI ROTATION
G132	GUIDE INDEX MECHANISM (SCREW M12-1.0x18+NUT)
VT096	HEX JAM NUT M8-1.25 SS
VT126	FLAT WASHER M6 SS
VT127	FLAT WASHER M8 SS
VT208	HEX HEAD SCREW M6-1.0x16 SS
VT210	HEX HEAD SCREW M6-1.0x25 SS
VT442	HEX SOCKET SET SCREW CUP POINT M6-1.0x6 SS
W6CUS	SS BEARING 6000 ZZ 10 x 20 X 6
X0270	BEARING PING 10 x 30 M6
X0450	SPRING PIN
Z8BCN	BUSHING 20 23 20E

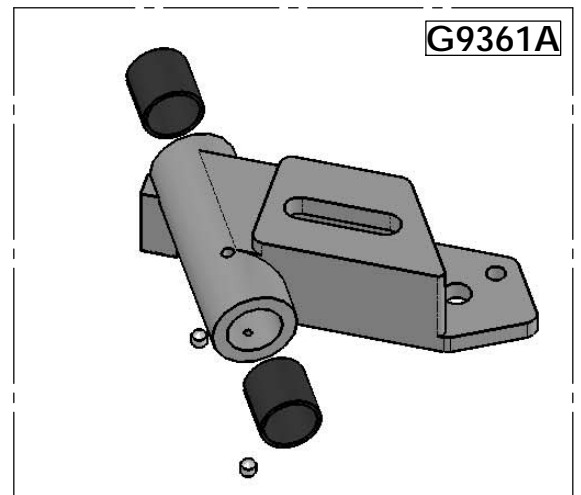



BIRO  
B 350 M  
MANUAL SLICER



STANDARD 8 - 2010

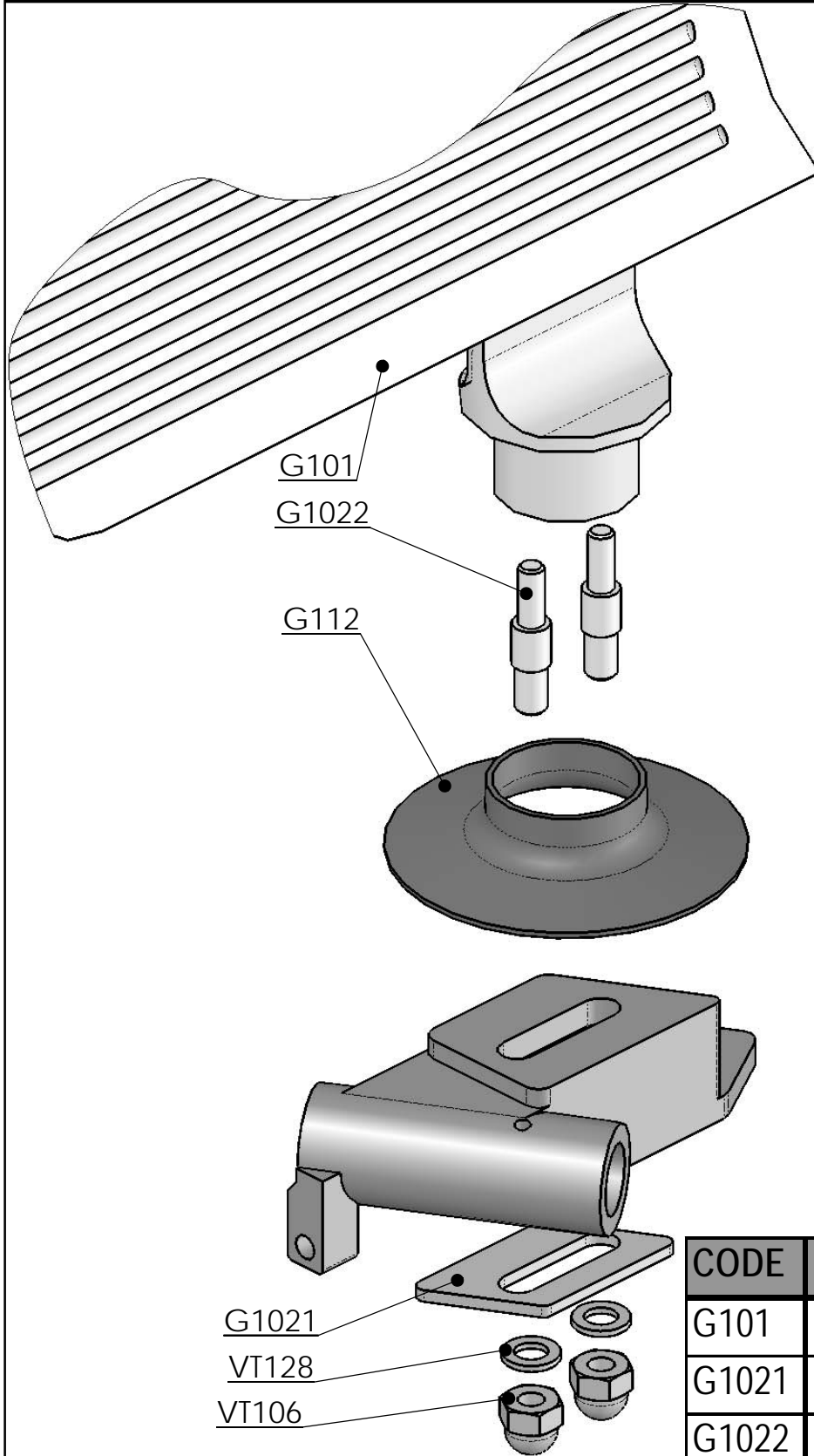

CODE	DESCRIPTION
G101	GAUGE PLATE
G1021	SS PLATE STRENGTHENING
G1022	LOCKING PLATE SCREW
G112	GAUGE PLATE PROTECTION
VT 106	ACORN HEX CAP M10-1.5 SS
VT 128	FLAT WASHER M10 SS



**BIRO  
B 350 M  
MANUAL SLICER**



**STANDARD 8 - 2010**

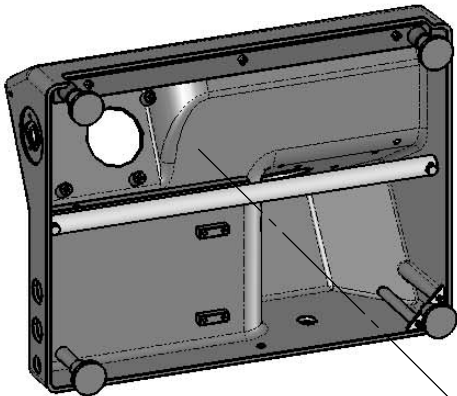
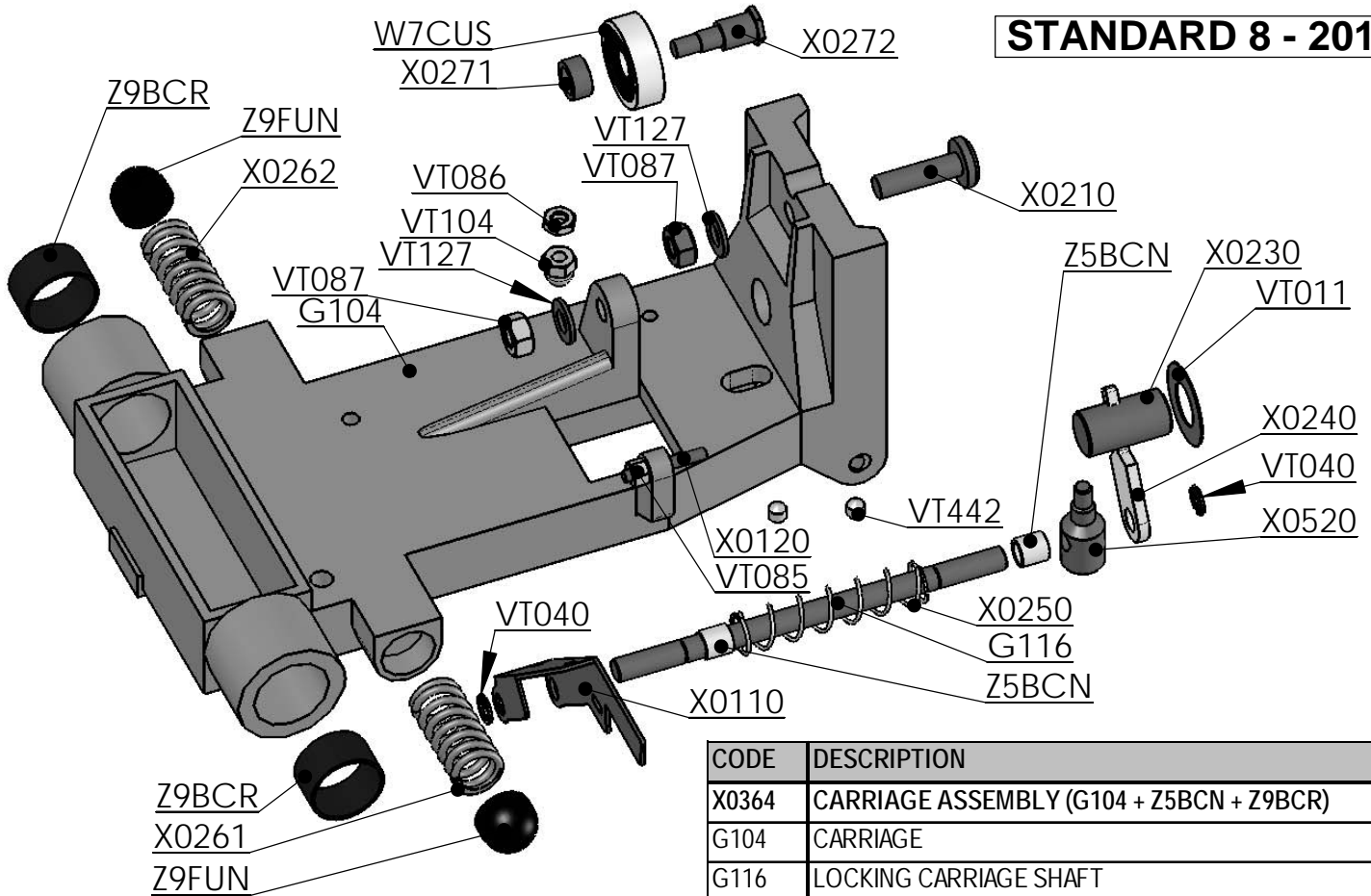

**X0364 CARRIAGE ASSEMBLY**

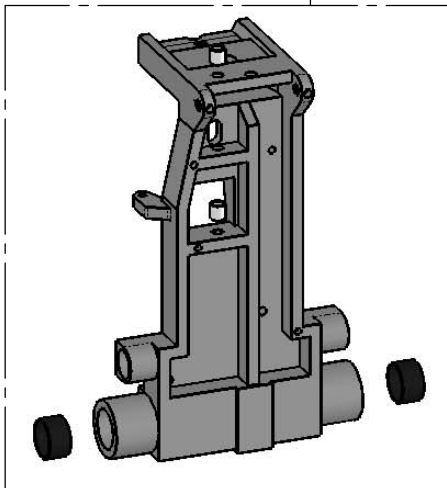

CODE	DESCRIPTION
X0364	CARRIAGE ASSEMBLY (G104 + Z5BCN + Z9BCR)
G104	CARRIAGE
G116	LOCKING CARRIAGE SHAFT
VT011	SPACER RING 16-30-1
VT040	E-CLIP M 6 SS
VT085	HEX NUT M5-0.8 SS
VT086	HEX NUT M6-1.0 SS
VT087	HEX NUT M8-1.25 SS
VT104	ACORN HEX CAP M6-1.0 SS
VT127	FLAT WASHER M8 SS
VT442	HEX SOCKET SET SCREW CUP POINT M6-1.0x6 SS
VT447	HEX SOCKET SET SCREW CONE POINT M5-0.8x8 SS
W7CUS	BEARING
X0110	BRACKET
X0120	GUIDE PIN
X0210	CAP SCREW
X0230	LOCKING SUPPORT TRAY ASSY
X0240	LOCKING SHAFT MECHANISM
X0250	SPRING - LOCKING CARRIAGE
X0261	SPRING - CARRIAGE L 45mm
X0262	SPRING - CARRIAGE L 65mm
X0271	SPACER - BEARING
X0272	BEARING PIN
X0520	LOCKING SHAFT MEC. PART 2
Z5BCN	BUSHING10 8 10 E
Z9BCR	BUSHING 25 28 25 E
Z9FUN	BUMPER - SLIDE ROD
ZZRMT	SCREW M6-1.0x20

G9362 Complete Assembly

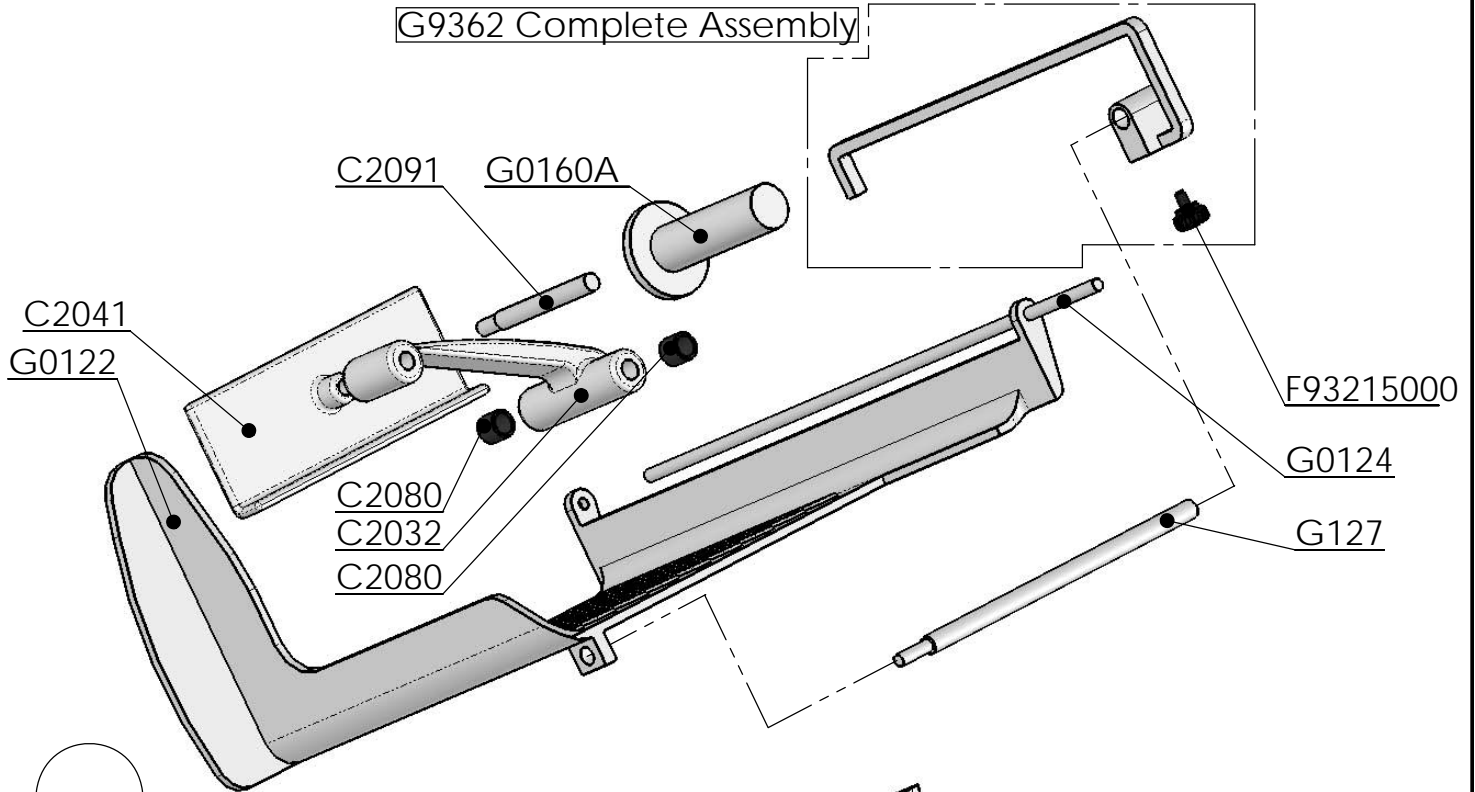

OLD VERSION

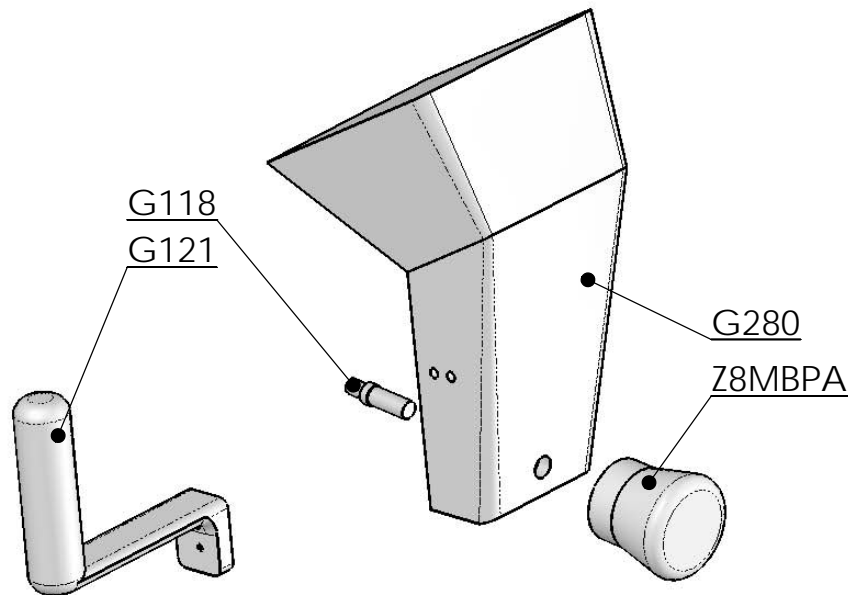

CODE	DESCRIPTION
G9362	FENCE ASSEMBLY
C2032	MEAT GRIP HOLDER
C2041	MEAT GRIP
C2080	BUSHING
C2091	HANDLE ASSY
F9321500	KNOB - LOCKING FENCE ASSEMBLY
G0122	CARRIAGE TRAY
G0124	SLIDE ROD ASSY
G0160A	ALU HANDLE
G118	KNOB SHAFT
G121	HANDLE - CARRIAGE
G127	FENCE SHAFT
G280	SUPPORT - TRAY ASSY
Z9MBPA	ALU KNOB - SUPPORT TRAY



BIRO  
B 350 M  
MANUAL SLICER



NEW VERSION  
FROM S.N. 12309

STANDARD 8 - 2010

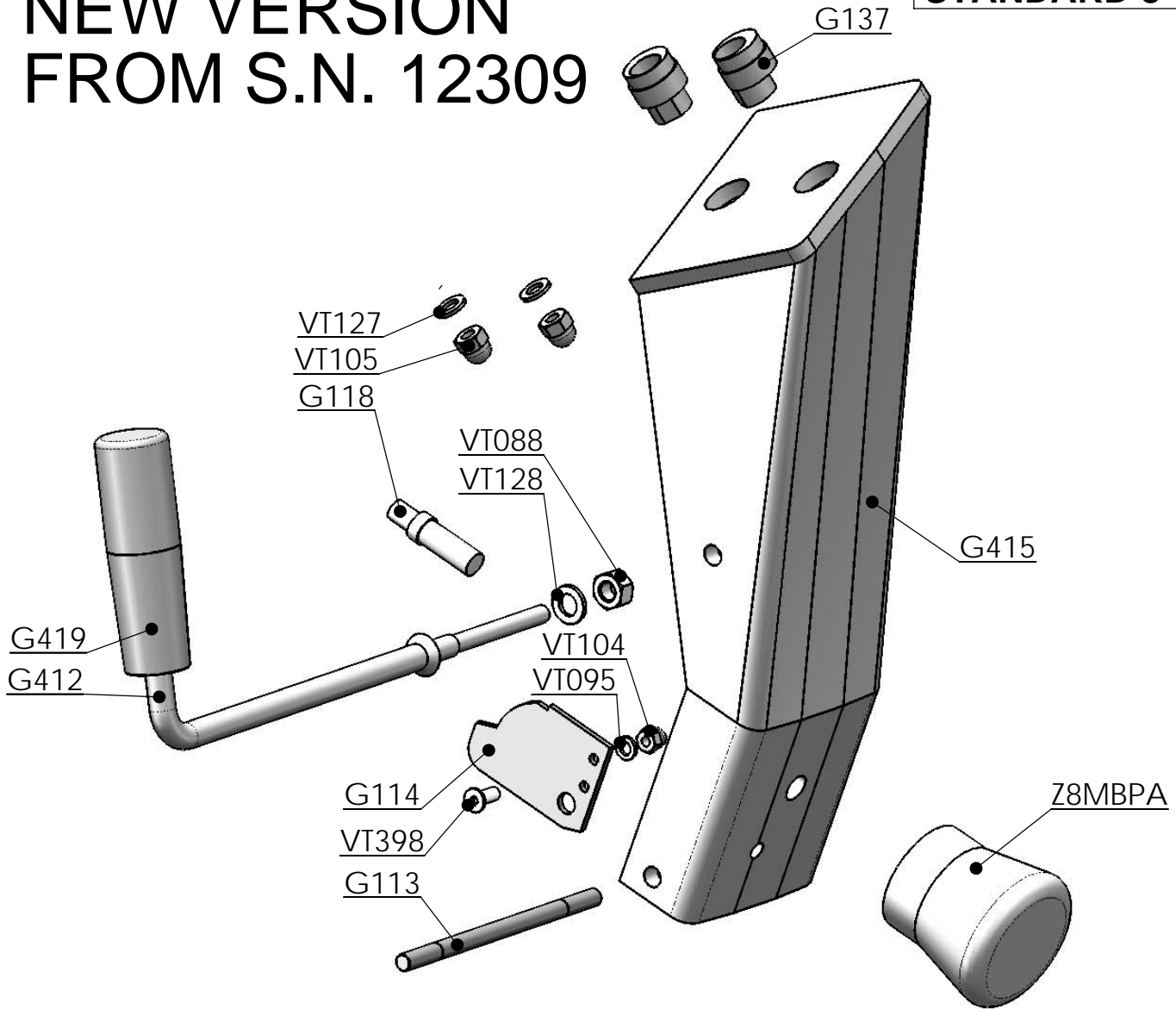

CODE	DESCRIPTION
G113	SHAFT PIVOT RETURN
G114	LOCKING CARRIAGE PLATE
G118	KNOB SHAFT
G137	REGULATION SHAFT
G412	HANDLE -SHAFT - CARRIAGE
G415	SUPPORT - TRAY ASSY
G419	HANDLE - CARRIAGE
VT088	HEX NUT M10-1.5 SS
VT095	HEX JAM NUT M6-1.0 SS
VT104	ACORN HEX CAP M6-1.0 SS
VT105	ACORN HEX CAP M8-1.25 SS
VT127	FLAT WASHER M8 SS
VT128	FLAT WASHER M10 SS
VT398	HEX SOCKET SLOTTED FLAT HEAD M6-1.0x16 SS
Z8MBPA	ALU KNOB - SUPPORT TRAY

STANDARD 8 - 2010

# NEW VERSION FROM S.N. 12309

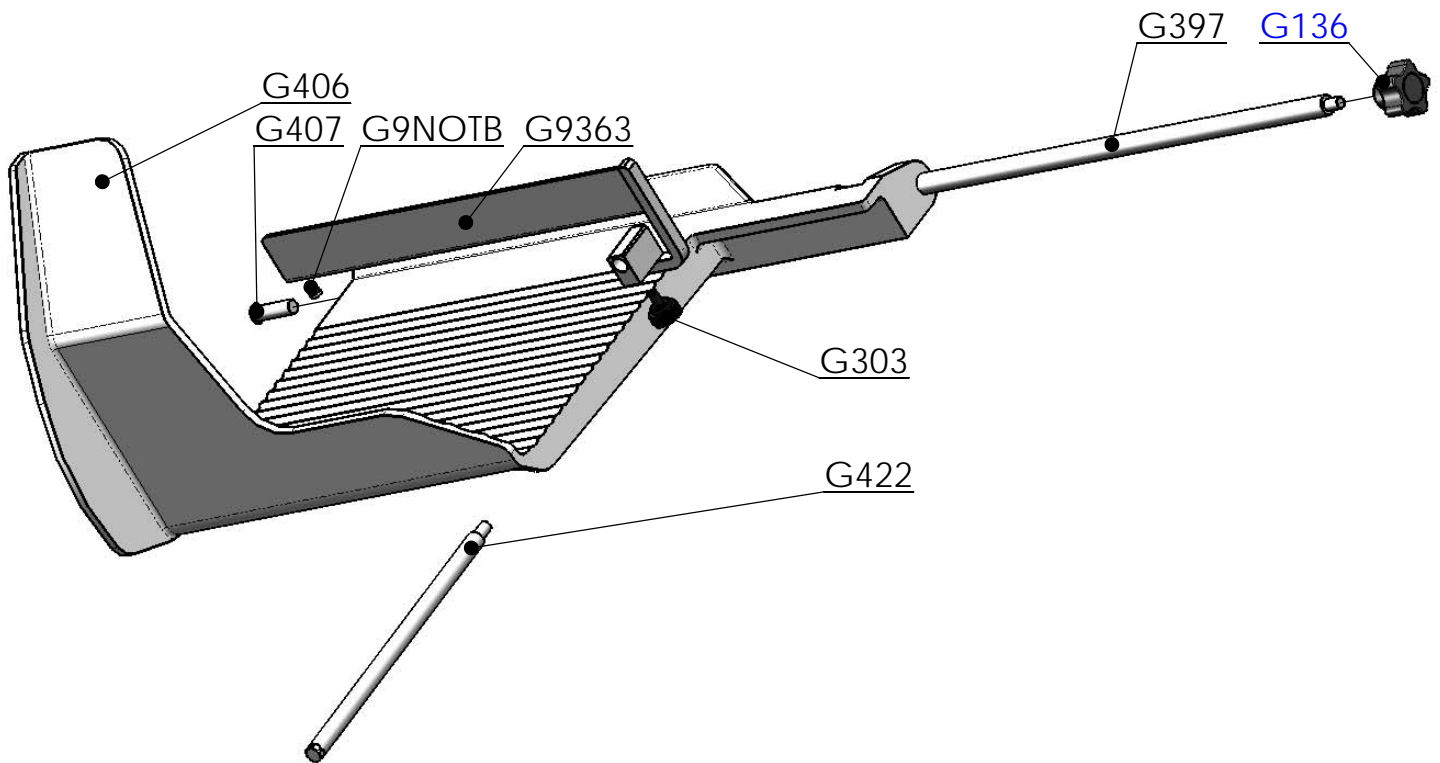

CODE	DESCRIPTION
G136	ALU KNOB
G303	KNOB - LOCKING FENCE ASSEMBLY
G397	SLIDE ROD ASSY
G406	CARRIAGE TRAY
G407	PIN
G422	FENCE SHAFT
G9363	FENCE
G9NOTB	BUMPER
VT 458	HEX SOCKET SET SCREW FLAT POINT M8-1.25x35 SS

# VERSION TILL S.N. 14028

STANDARD 8 - 2010

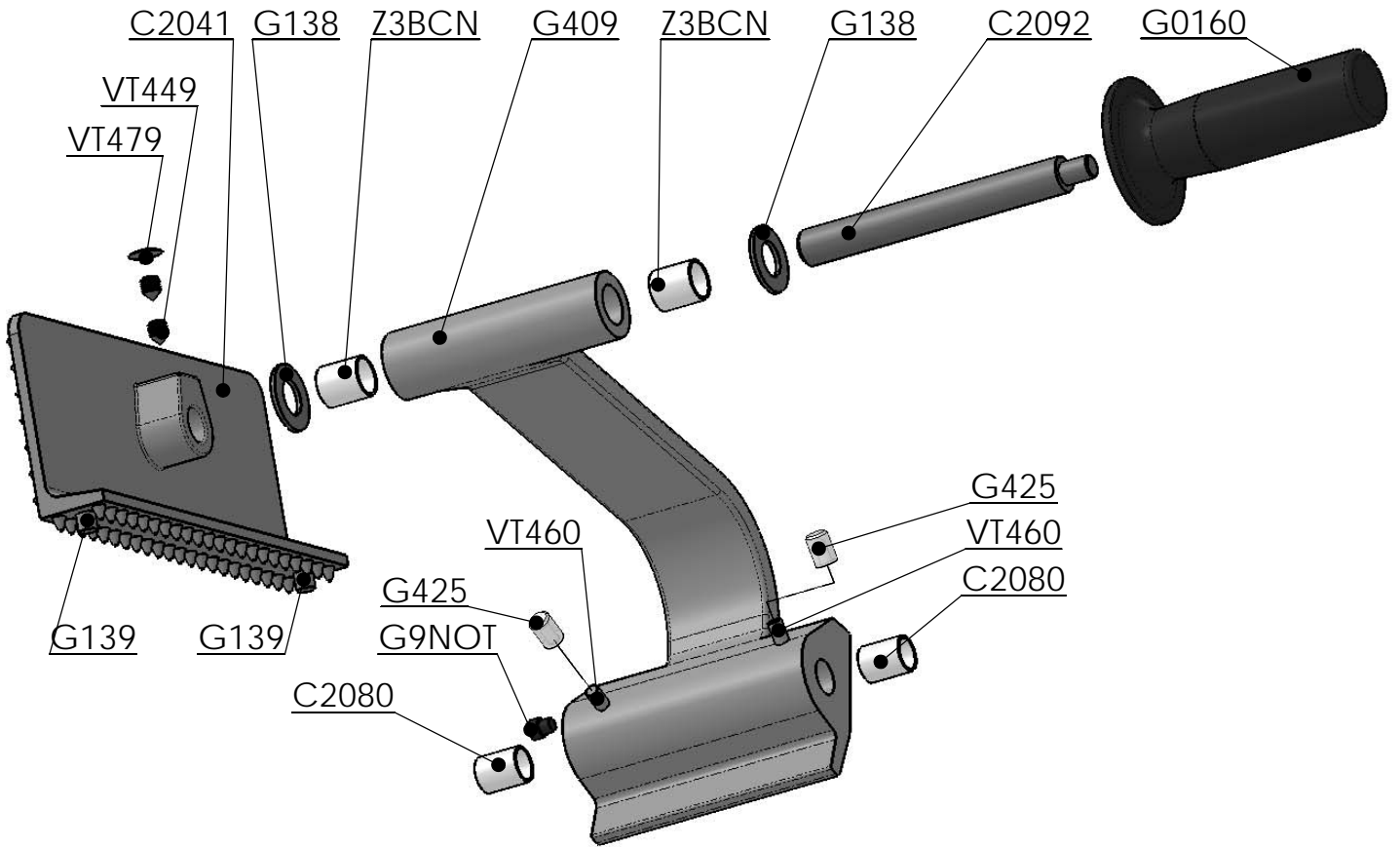

X0363 GRIP HOLDER ASSEMBLY

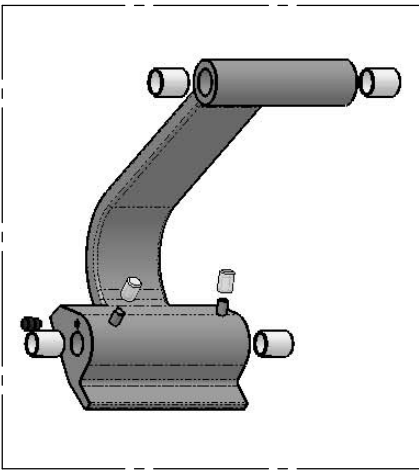

CODE	DESCRIPTION
X0363	GRIP HOLDER ASSEMBLY ( G409+C2080+G9NOT+G425+VT460+Z3BCN )
C2041	PRODUCT GRIP
C2080	BUSHING 14-16-20 E
C2092	HANDLE BAR
G0160	HANDLE
G138	SEAL
G139	PLASTIC SLIDING PIN
G409	PRODUCT GRIP HOLDER
G425	PLASTIC CAP
G9NOT	BUMPER
VT 449	HEX SOCKET SET SCREW CONE POINT M8-1.25x8 SS
VT 460	HEX SOCKET SET SCREW FLAT POINT M6-1.0x20 SS
VT 479	PROTECTIVE CAP d.15.5-4.1x3
Z3BCN	BUSHING 16-18-20 E

# NEW VERSION FROM S.N. 14029

STANDARD 8 - 2010

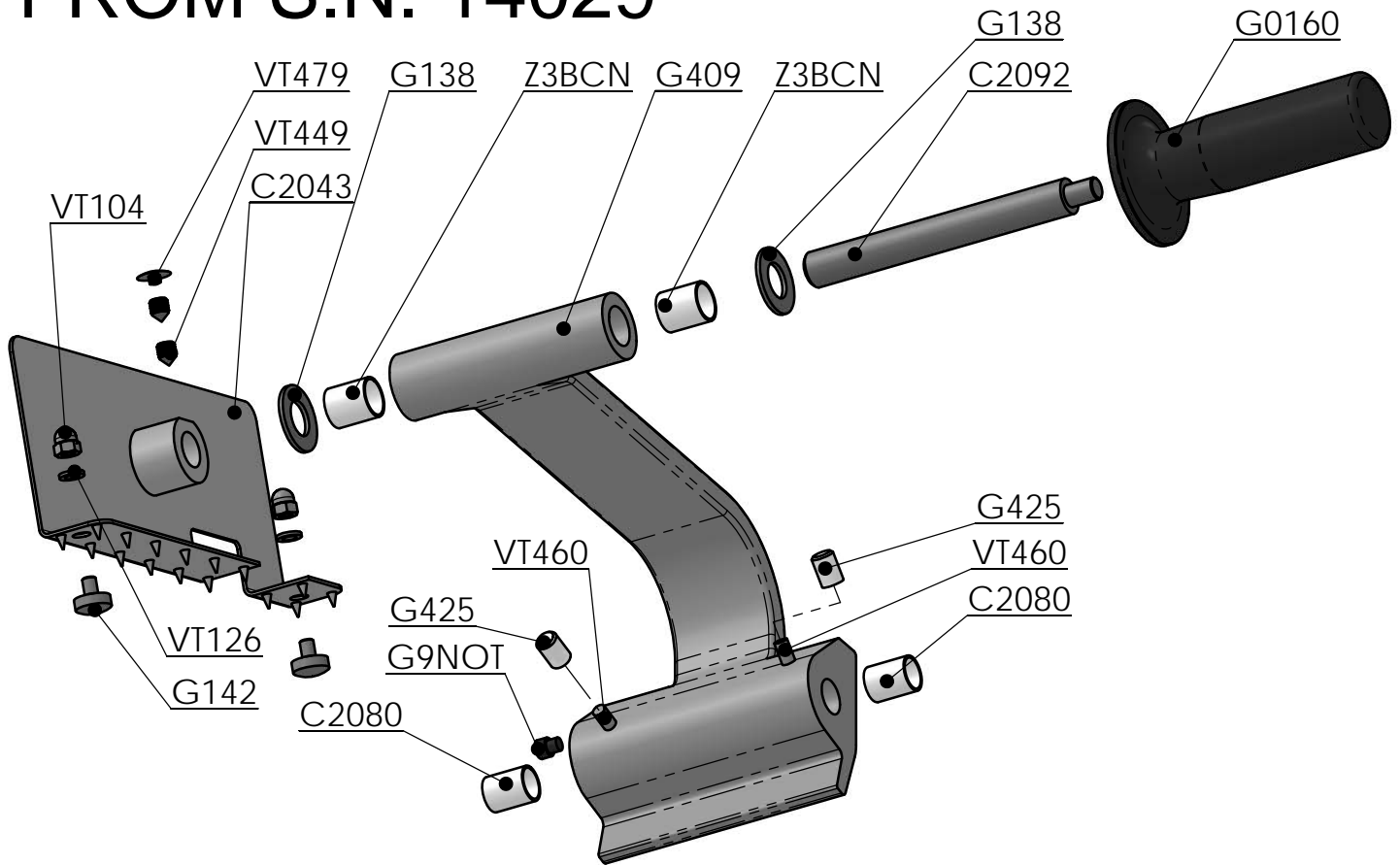

X0363 GRIP HOLDER ASSEMBLY

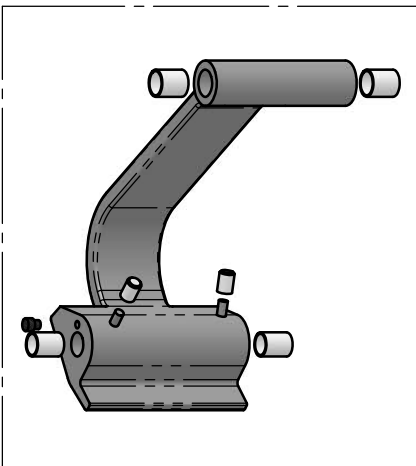

CODE	DESCRIPTION
X0363	GRIP HOLDER ASSEMBLY ( G409+C2080+G9NOT+G425+VT460+Z3BCN )
C2043	PRODUCT GRIP
C2080	BUSHING 14-16-20 E
C2092	HANDLE BAR
G0160	HANDLE
G138	SEAL
G142	PLASTIC SLIDING PIN
G409	PRODUCT GRIP HOLDER
G425	PLASTIC CAP
G9NOT	BUMPER
VT 104	ACORN HEX CAP M6-1.0 SS
VT 126	FLAT WASHER M6 SS
VT 449	HEX SOCKET SET SCREW CONE POINT M8-1.25x8 SS
VT 460	HEX SOCKET SET SCREW FLAT POINT M6-1.0x20 SS
VT 479	PROTECTIVE CAP d.15.5-4.1x3
Z3BCN	BUSHING 16-18-20 E

**TILL S/N: 80415**

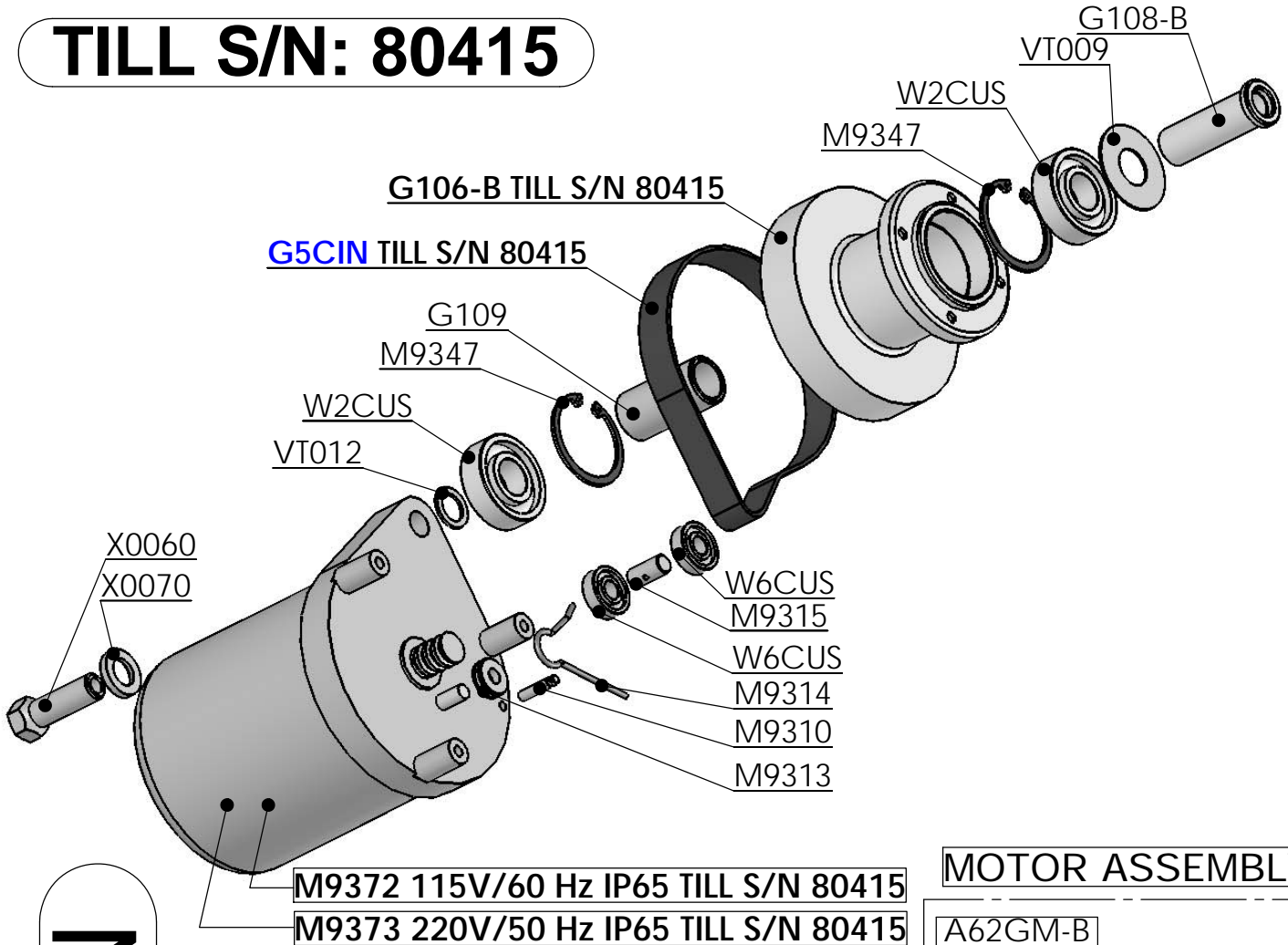

**OLD VERSION**

CODE	DESCRIPTION
G106 B	PULLEY B350M UP S/N 80415
G108 B	SHAFT - KNIFE 25 x 97
G109	SPACER
G5CIN	BELT TB2 11 x 400 UP S/N 80415
M9310	PIN 25 x 5
M9313	RING SUPPORTING SPRING 20 x 6
M9314	BEARING TENS. SPRING
M9315	BEARING PIN
M9347	RETAINING RING INTERNAL M47 SS
M9372	MOTOR - IP 65 115 VOLT 60 Hz UP S/N 80415
M9373	MOTOR - IP 65 220 VOLT 50 Hz UP S/N 80415
VT009	SPACER RING d. 20-46x1 SS
VT012	SPACER RING d. 20-28x1 SS
W2CUS	SS TRANSMISSION BEARING
W6CUS	SS BEARING 6000 ZZ 10 x 20 X 6
X0060	CAP SCREW
X0070	LOCK WASHER
CODE	DESCRIPTION
A62GM-B	MOTOR ASSEMBLY IP 65 115V/60Hz
A63GM-B	MOTOR ASSEMBLY IP 65 220V/50Hz

**MOTOR ASSEMBLY**

A62GM-B  
115V/60Hz  
IP65

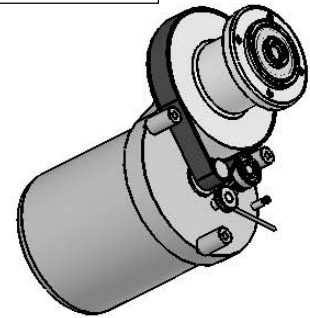

115V/60Hz IP65

A63GM-B  
220V/50Hz  
IP65

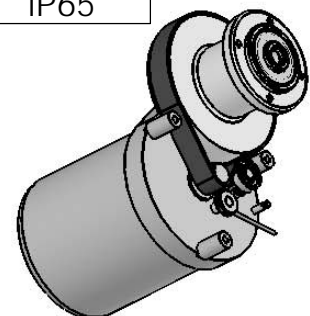

220V/50Hz IP65



BIRO  
B350 M  
MANUAL SLICER



# FROM S/N: 80416 TILL S/N 15111

**STANDARD 8 - 2010**

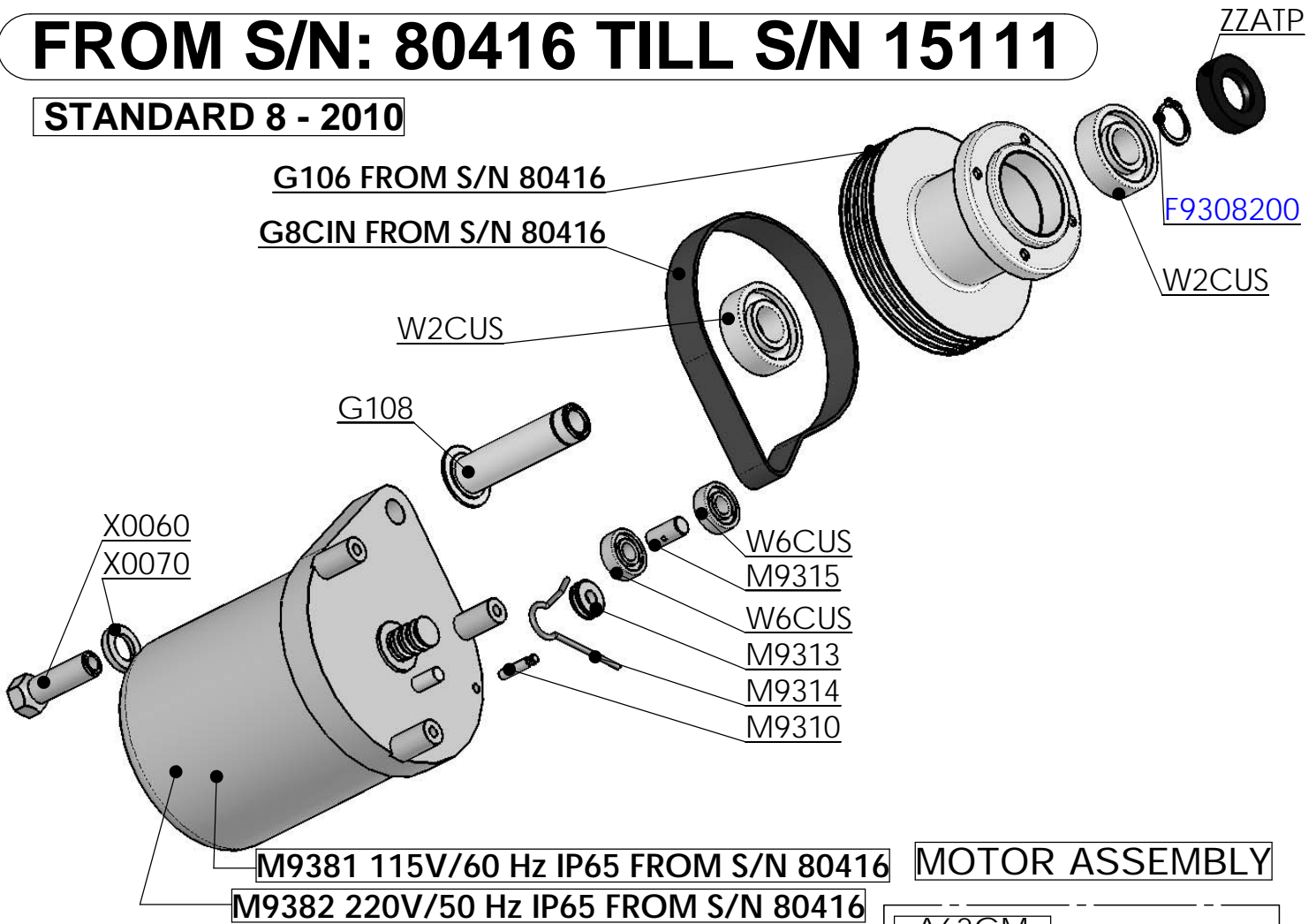

## MOTOR ASSEMBLY

CODE	DESCRIPTION
F9308200	RETAINING RING EXTERNAL M20 SS
G106	PULLEY B350M FROM S/N 80416
G108	SHAFT - KNIFE 29 x 97
G8CIN	BELT PJ 406 J9 FROM S/N 80416
M9310	PIN 25 x 5
M9313	RING SUPPORTING SPRING 20 x 6
M9314	BEARING TENS. SPRING
M9315	BEARING PIN
M9381	MOTOR - IP 65 115 VOLT 60 Hz
M9382	MOTOR - IP 65 220 VOLT 50 Hz
W2CUS	SS TRANSMISSION BEARING
W6CUS	SS BEARING 6000 ZZ 10 x 20 X 6
X0060	CAP SCREW
X0070	LOCK WASHER
ZZATP	SEAL
CODE	DESCRIPTION
A62GM	MOTOR ASSEMBLY IP 65 115V/ 60Hz
A63GM	MOTOR ASSEMBLY IP 65 220V/ 50Hz

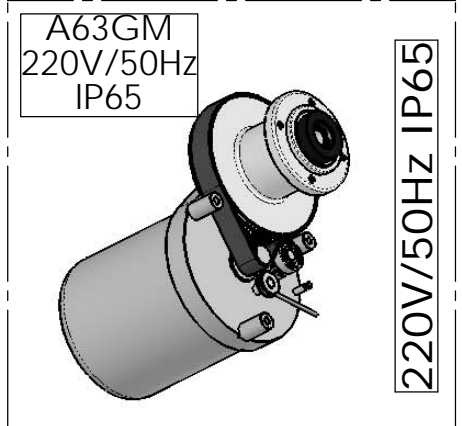
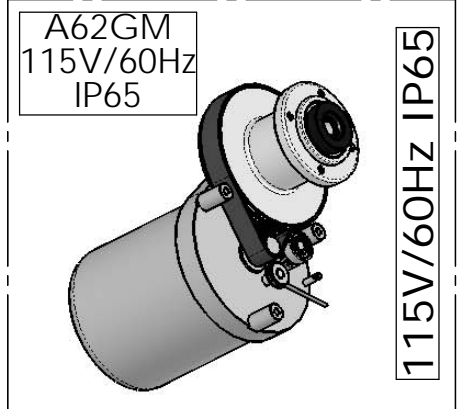



BIRO  
B350 M  
MANUAL SLICER



**FROM S/N: 15112**

**STANDARD 8 - 2010**

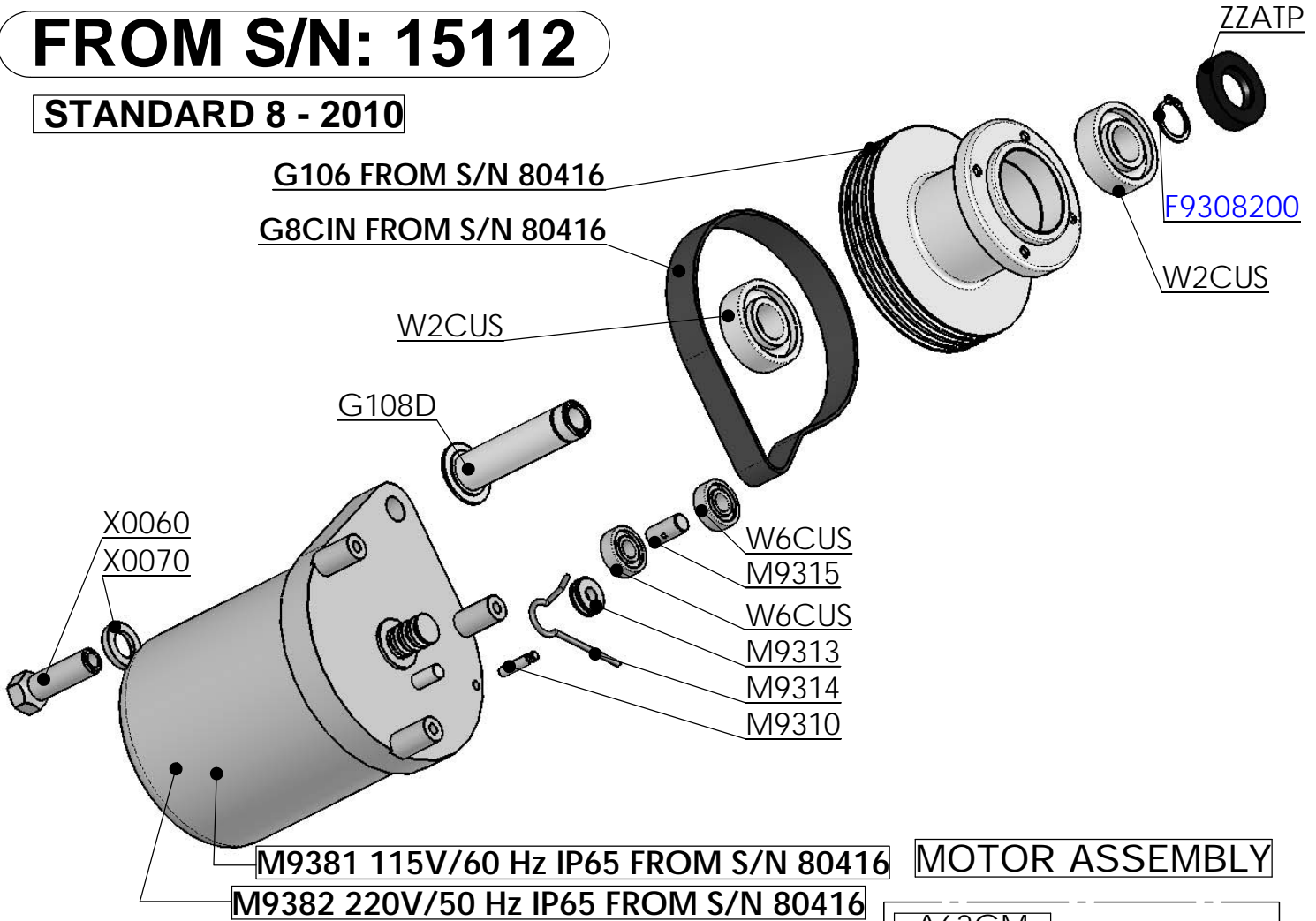

CODE	DESCRIPTION
F9308200	RETAINING RING EXTERNAL M20 SS
G106	PULLEY B350M FROM S/N 80416
G108D	SHAFT - KNIFE 29 x 97
G8CIN	BELT PJ 406 J9 FROM S/N 80416
M9310	PIN 25 x 5
M9313	RING SUPPORTING SPRING 20 x 6
M9314	BEARING TENS. SPRING
M9315	BEARING PIN
M9381	MOTOR - IP 65 115 VOLT 60 Hz
M9382	MOTOR - IP 65 220 VOLT 50 Hz
W2CUS	SS TRANSMISSION BEARING
W6CUS	SS BEARING 6000 ZZ 10 x 20 X 6
X0060	CAP SCREW
X0070	LOCK WASHER
ZZATP	SEAL
CODE	DESCRIPTION
A62GM	MOTOR ASSEMBLY IP 65 115V/ 60Hz
A63GM	MOTOR ASSEMBLY IP 65 220V/ 50Hz

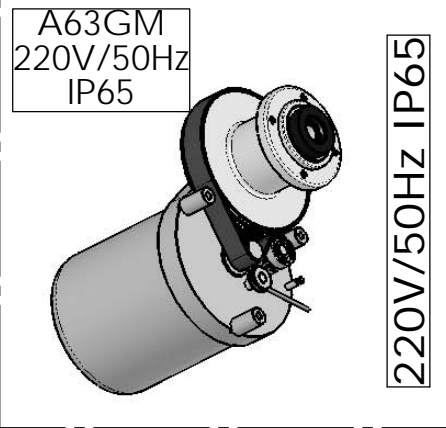
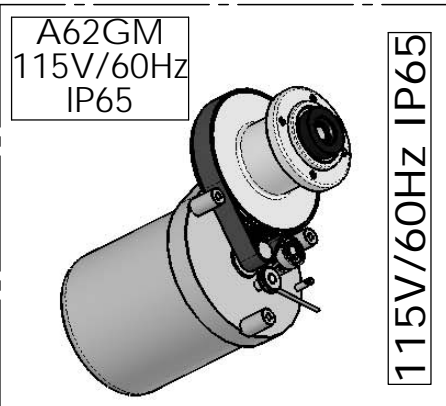



BIRO  
B 350 M  
MANUAL SLICER



STANDARD 8 - 2010

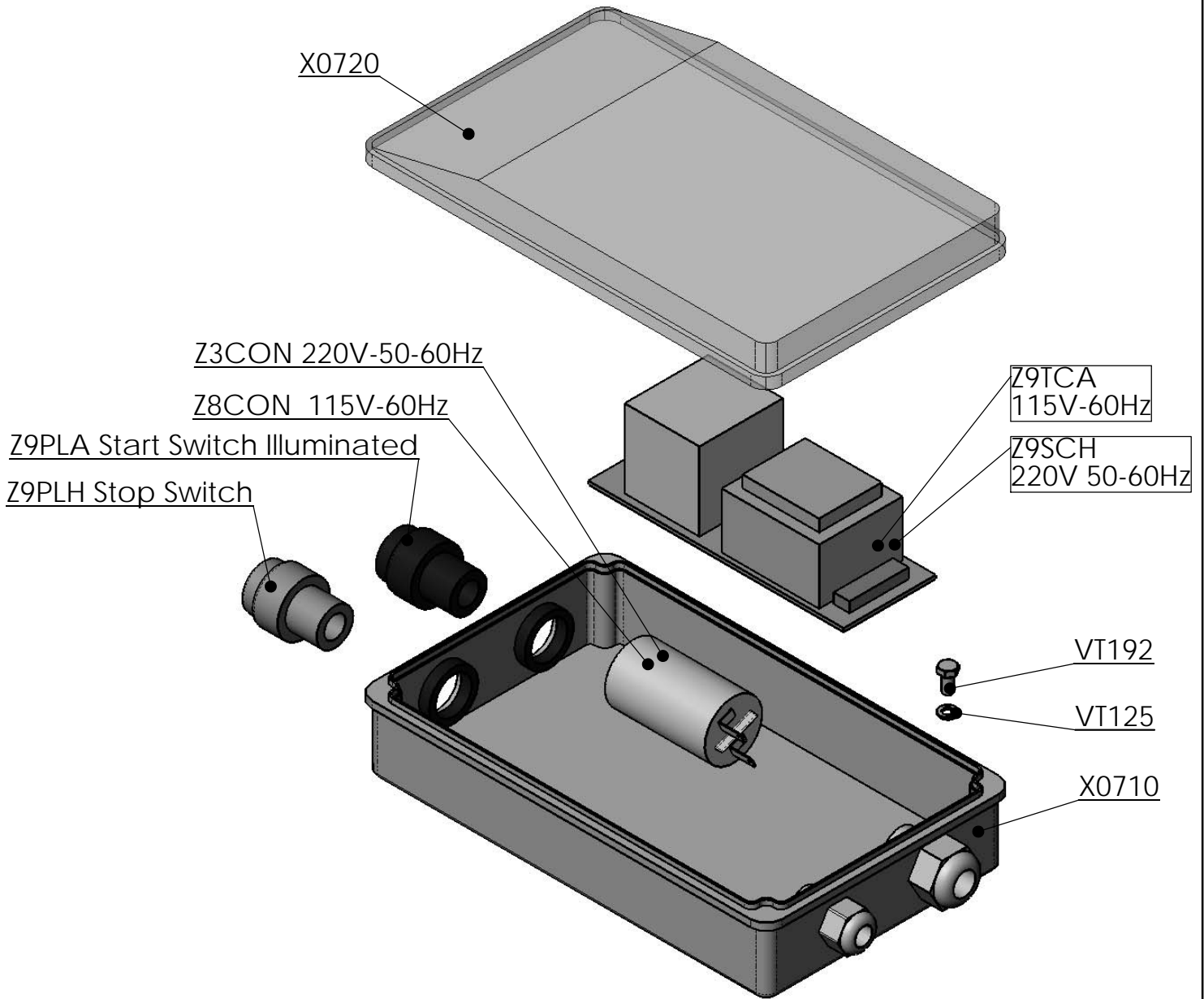

CODE	DESCRIPTION
GRSTA	COMPLETE CONTROL BOX 115V-60Hz
GRSTS	COMPLETE CONTROL BOX 220V-50/60Hz
VT 125	FLAT WASHER M5 SS
VT 192	HEX HEAD SCREW M5-0.8x10 SS
X0710	ELECTRIC BOX - BASE
X0720	PLASTIC COVER
Z3CON	CAPACITOR 10 Mf 220V-50/60Hz
Z8CON	CAPACITOR 30 Mf 115V-60Hz
Z9PLA	START SWITCH - IP 69
Z9PLH	STOP SWITCH - IP 69 RED
Z9SCH	CARD 220V/50-60Hz
Z9TCA	CARD 115V/60Hz

Complete Assembly

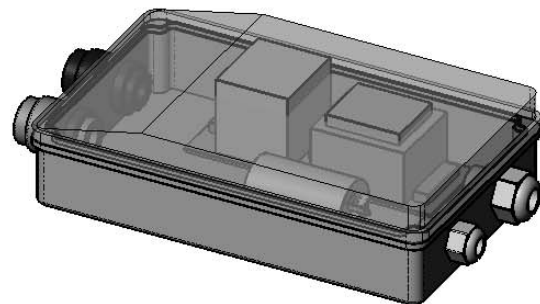

GRSTA  
MONO-PHASE  
115V-60Hz

GRSTS  
MONO PHASE  
220V-50/60Hz

**STANDARD 8 - 2010**

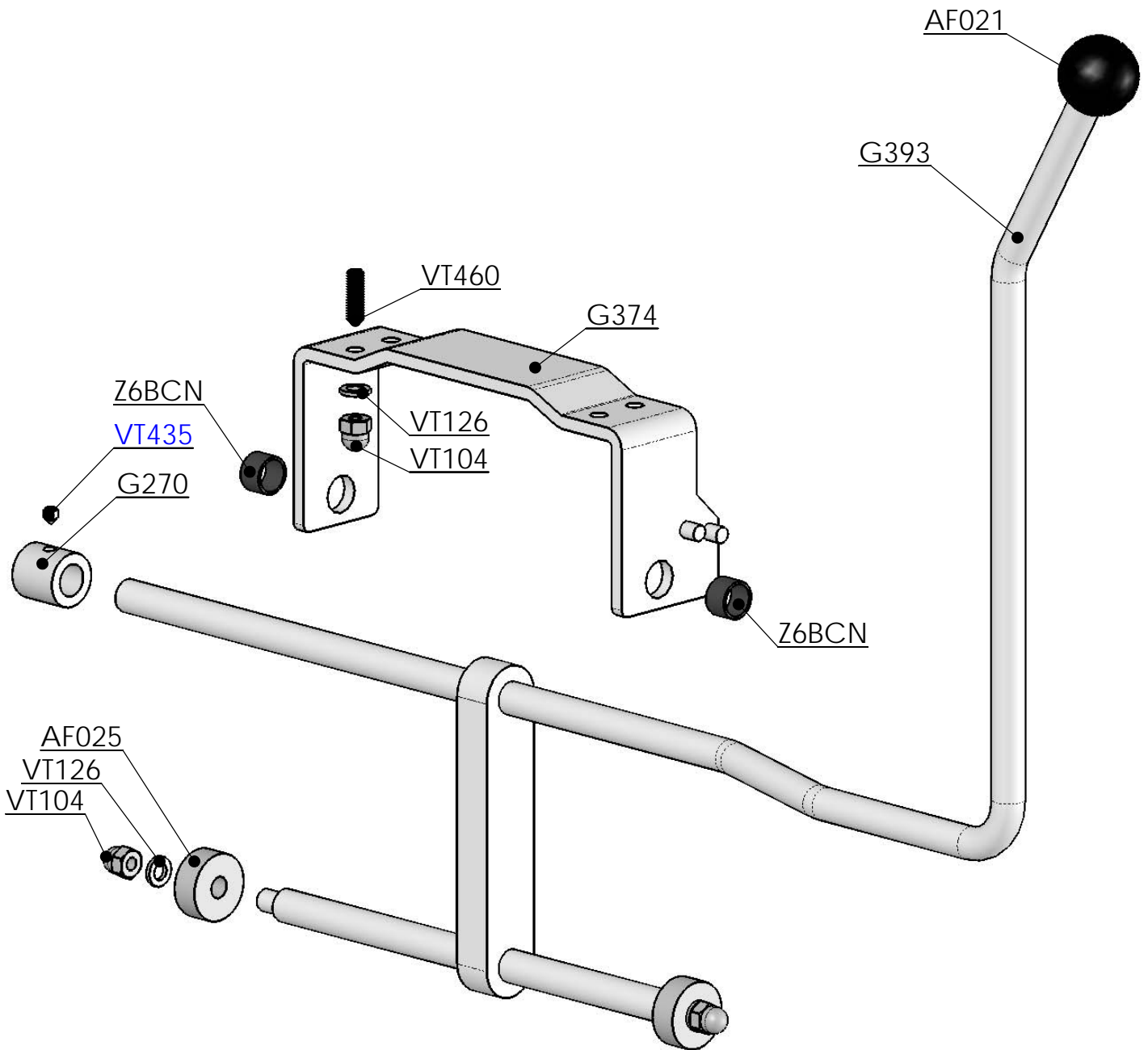

CODE	DESCRIPTION
AF021	KNOB Ø 40 M10
AF025	PLASTIC WHEEL
G270	LEVER SPACER
G374	SUPPORT
G393	LIFT LEVER
VT 104	ACORN HEX CAP M6-1.0 SS
VT 126	FLAT WASHER M6 SS
VT 435	HEX SOCKET SET SCREW CUP POINT M5-0.8x5 SS
VT 460	HEX SOCKET SET SCREW FLAT POINT M6-1.0x20 SS
Z6BCN	BUSHING 12 14 9



BIRO  
B 350 M  
MANUAL SLICER  
UP S/N 80415



STANDARD 8 - 2010

OLD VERSION

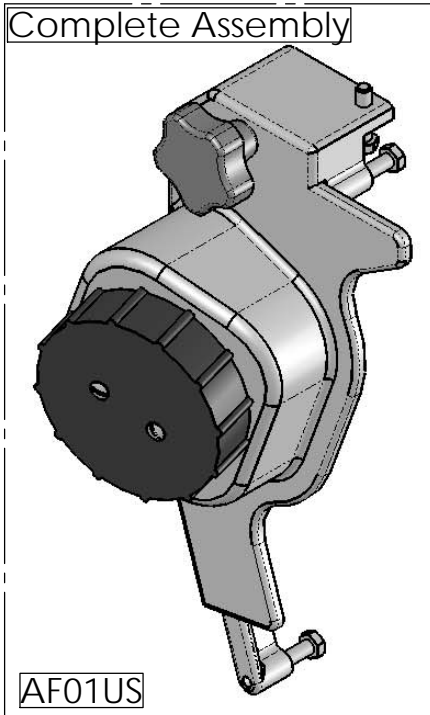
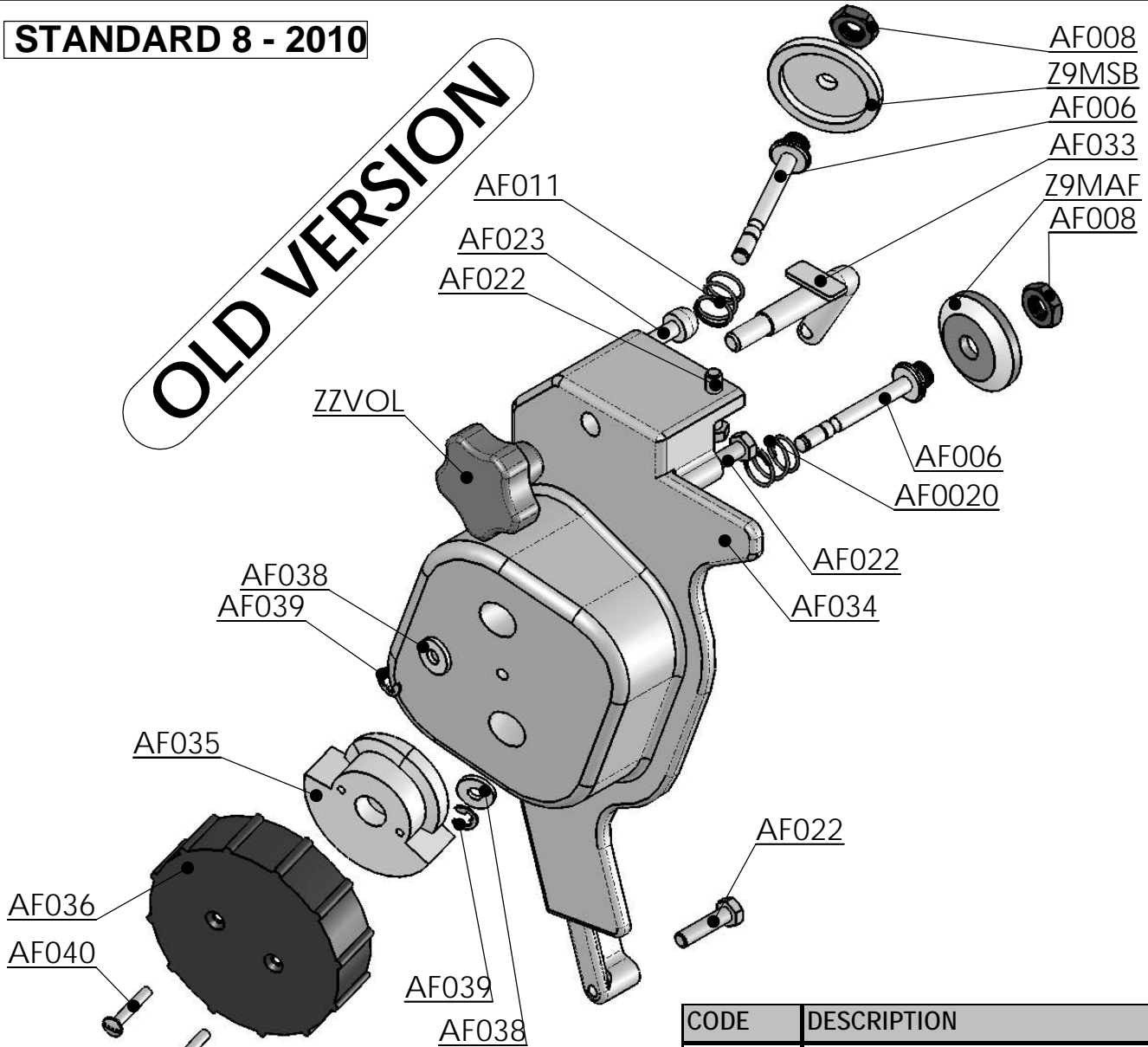

AF01US

CODE	DESCRIPTION
AF01US	SHARPENER - COMPLETE ASSEMBLY
AF006	SHAFT - SHARP + CLEANING STONE
AF008	NUT - SPECIAL
AF011	SPRING - CLEANING STONE
AF020	SPRING - SHARPENING STONE
AF022	SCREW - PLASTIC
AF023	SCREW - MAIN GUIDE - PLASTIC
AF033	ARM
AF034	HOUSING -
AF035	SHARPENER CAM
AF036	KNOB - SHARPENER
AF038	WASHER - PLASTIC
AF039	RING - RETAINER - UNI 7434
AF040	SCREW - TC 5 x 10
Z9MAF	STONE - SHARPENING
Z9MSB	CLEANING STONE
ZZVOL	KNOB - BLADE G. + SHARPENER



THE BIRO MANUFACTURING COMPANY  
1114 W. Main Street  
Marblehead, OH 43440 USA  
Ph. 419-798-4451 Fax 419-798-9106  
Email: [service@birosaw.com](mailto:service@birosaw.com)