



Model EMG-32

Ergonomic Mixer-Grinder/Chopper

Operating Manual and Parts List



☆ IMPORTANT NOTICE ☆
This Manual contains important
safety instruction which must
be strictly followed when using
this equipment.

Item No. EMG92099
Form No. EMG32MAN-9-16-11-B

TABLE OF CONTENTS:

	PAGE
NOTICE TO OWNERS AND OPERATORS	1
SAFETY TIPS	2
INSTALLATION	3
OPERATION	5
GRINDER KNIFE & PLATE DO'S & DON'TS	6
FOOD HANDLING TO PREVENT CONTAMINATION	6
TO PROCESS PRODUCT	6
MAINTENANCE	7
GRINDER BOWL INSTALLATION	7
LUBRICATION	7
CHAIN TENSION	8-9
OPERATOR'S NOTES	9
OPTIONAL EAGLE DRIVE BELT TENSIONING INSTRUCTIONS	10-11
OPERATOR'S NOTES	12
GROVE GEAR REDUCER REPLACEMENT & LUBRICATION	13-15
MIXER DRIVE SHAFT SEAL REPLACEMENT	16
CLEANING	17
MIXING PADDLE: INSTALLATION; S/N's 6001 to 6057	18
MIXING PADDLE HISTORY BY SERIAL NUMBER	19
ELECTRIC FOOTSWITCH PARTS LIST & DIAGRAM	20
ELECTRICAL SCHEMATIC WITH ELECTRIC FOOTSWITCH	21-22
PNEUMATIC FOOTSWITCH PARTS LIST & DIAGRAM	23
ELECTRICAL SCHEMATIC WITH PNEUMATIC FOOTSWITCH	24-25
ELECTRICAL SUBPLATE COMPONENTS	26
PARTS LIST, NOT SHOWN PARTS	27
FASTENERS	27
PARTS LIST	28-32
BELT DRIVE OPTION	31
JOURNAL BOX ASSEMBLY PARTS DIAGRAM- RIGHT HAND HINGE ASSEMBLY	33
STANDARD EQUIPMENT	34
SAFETY LABEL LOCATIONS	34-35
TANDEM OPERATION ILLUSTRATION	36
OPERATOR SIGNATURE PAGE	37
LIMITED WARRANTY	38

NOTICE TO OWNERS AND OPERATORS

BIRO's products are designed to process food products safely and efficiently. Unless the operator is properly trained and supervised, however, there is the possibility of a serious injury. It is the responsibility of the owner to assure that this machine is used properly and safely, strictly following the instructions contained in this Manual and any requirements of local law.

No one should use or service this machine without proper training and supervision. All operators should be thoroughly familiar with the procedures contained in this Manual. Even so, BIRO cannot anticipate every circumstance or environment in which its products will be used. You, the owner and operator, must remain alert to the hazards posed by the function of this equipment particularly the ROTATING GRINDING AUGER and the ROTATING MIXING PADDLE, which can severely injure an inattentive operator amputating fingers and limbs. No one under eighteen (18) years of age should operate this equipment. If you are uncertain about a particular task, ask your supervisor.

This Manual contains a number of safe practices in the SAFETY TIPS section. Additional warnings are placed throughout the Manual. Warnings relate to your personal safety are indicated by:



or



Warnings related to possible damage are indicated by:



BIRO also has provided warning labels on the equipment. If any warning label, instruction label or Manual becomes misplaced, damaged, or illegible, please contact your nearest Distributor or BIRO directly for a replacement.

Remember, however, this Manual or the warning labels do not replace the need to be alert and to use your common sense when using this equipment.

This Manual applies to all **BIRO** Ergonomic Mixer Grinder/Choppers.

- NOTE -

“A copy of this manual is included with each MODEL EMG-32 MIXER-GRINDER.”

“The descriptions and illustrations contained in this manual are not binding. The manufacturer reserves the right to introduce any modification without updating the manual.”

SAFETY TIPS



ROTATING GRINDING AUGER & ROTATING MIXING PADDLES TO AVOID SERIOUS PERSONAL INJURY

- **NEVER** Touch This Machine without Training and Authorization by Your Supervisor.
- **NEVER** Place Hands into Machine Input or Output Openings.
- **NEVER** Open Machine During Operation.
- **ONLY** Use a Qualified Electrician to Install According to Local Building Codes: Machine **MUST** Be Properly Grounded.
- **ALWAYS** Connect to **Proper** Voltage & Phase.
- **ONLY** Install on Level, Non-Skid Surface in a Clean, Well-Lighted Work Area Away from Children and Visitors.
- **ALWAYS** Lock Machine Castors After Moving This Machine.
- **NEVER** Use This Machine For Non Food Products.
- **NEVER** Operate Machine With Product Mixer Safety Cover Open or Removed or Magnetic Interlock Switch By-Passed.
- **ALWAYS** Turn Off, Unplug Machine From Power Source and Perform Lockout/Tagout Procedure to this Machine **BEFORE** Attempting to Unjam or Unclog, Cleaning or Servicing.
- **NEVER** Leave Machine Unattended While Operating.
- **NEVER** Alter This Machine From its Original Form as Shipped From Factory. **DO NOT** Operate Machine With Missing Parts.
- **PROMPTLY REPLACE** Any Worn or Illegible Warning Labels.
- **ALWAYS** Read Operation and Service Manual **BEFORE** Operating, Cleaning, or Servicing.
- **USE ONLY BIRO** Parts and Accessories Properly Installed.

INSTALLATION



TO AVOID SERIOUS PERSONAL INJURY, PROPERLY INSTALL EQUIPMENT IN ADEQUATE WORK AREA

- **ALWAYS** Use Qualified Technician and Electrician for Installation.
- **ALWAYS** Connect to **Proper** Voltage & Phase.
- **ALWAYS** Install Equipment in Work Area with Adequate Light and Space Away From Children and Visitors.
- **ONLY** Operate on a Solid, Level, Non-Skid Surface.
- **ALWAYS** Lock Machine Castors After Moving Machine to Operating Location.
- **NEVER** Bypass, Alter, or Modify This Equipment in Any Way From Its Original Condition.
- **NEVER** Operate Machine With Product Mixer Safety Cover Open or Removed or Magnetic Interlock Switch By-Passed.
- **NEVER** Operate Without all Warning Labels Attached and Owner/Operator Manual Available to the Operator.
- **USE ONLY BIRO** Parts and Accessories Properly Installed.

UNCRATING AND SET UP

1. Read this Manual thoroughly before installation and operation. **Do not** proceed with installation and operation if you have any questions or do not understand anything in this Manual. Contact your local Distributor, or BIRO **first**.
2. Remove all banding, shipping carton, and all equipment from inside the tub. Then take machine off shipping pallet.
3. This machine is shipped with the adjustable legs fully retracted. The legs allow for a height adjustment from the floor to centerline of bowl 32” minimum to 38” maximum.
4. This machine weighs approximately 700 pounds. To avoid accidents block up machine after raising to desired operating height.
5. Fasten the casters to the legs.
6. The adjustable legs can be unbolted and lowered to the floor. Replace bolts and nuts and tighten securely.
7. Install machine on a level, non-skid surface in a well-lighted work area away from children and visitors.
8. This machine is complete except for knife and plate. There is a bowl shipping plug (cardboard) placed in the output end of the grinding bowl to retain the grinding auger during shipment. **REMOVE THE BOWL SHIPPING PLUG AND THE GRINDING AUGER.**
9. After checking and making sure the power supply is correct, plug in your machine. **NEVER OPERATE MACHINE WITH PRODUCT MIXER SAFETY COVER OPEN.** (Machine will not run with cover open.)
10. Machine must be properly grounded. Use qualified electrician to install according to local building codes.

MOTOR WIRING AND ELECTRICAL REQUIREMENTS

1. Interchange of current is made in motor outlet box. Leads are properly marked. Changing instructions are on the motor plate or motor outlet box.
2. All mixer-grinder/choppers are wired 208 volts unless otherwise specified. Be sure motor specifications (voltage, cycle, phase) match power supply line. Be sure line voltage is up to specification.
3. Electrical connections to be in accordance with safety codes and National Electrical Code.
4. Rated voltage of the unit shall be identical with full supply voltage.
5. Voltage drop on the supply line shall not exceed 10% of full supply voltage.
6. The feederline conductor size in the raceway from the branch circuit to the unit must be correct to assure adequate voltage under heavy starting and short overload conditions.
7. The feederline conductor shall only be used for the supply of one unit of the relevant horsepower. For connections of more than one unit on the same feederline, a local electrician will have to be consulted to determine the proper conductor size.
8. The size of the electrical wiring required from the power source to the mixer-grinder/chopper is a **MINIMUM OF No. 10 WIRE.**
9. The BIRO Manufacturing Company is not responsible for permanent wiring, connection or installation.



NOTE TO OWNER AND ELECTRICIAN: IF THIS MACHINE IS NOT CORD AND PLUG CONNECTED TO THE ELECTRICAL SUPPLY SOURCE, THEN IT SHOULD BE EQUIPPED WITH, OR CONNECTED TO, A LOCKABLE, MANUALLY-OPERATED DISCONNECT SWITCH (OSHA 1010.147)

MOTOR SPECIFICATIONS

GRINDER MOTOR

HP	KW	VOLTS	HZ	PH	AMPS
7.5	5.6	208/230	60	3	24/22
7.5	5.6	220	50	3	28
7.5	5.6	380/415	50	3	12.7/12.4
7.5	5.6	460	60	3	11
7.5	5.6	550	60	3	9.2

MIXER MOTOR

.75	.56	208/230	60	3	3.0/2.8
.75	.56	220	50	3	3.6
.75	.56	380/415	50	3	1.8/1.9
.75	.56	460	60	3	1.5
.75	.56	550	60	3	1.2

10. Two sets of green and red pushbuttons are located at the front of the machine that activate the magnetic contacts that control the mix and grind motors. The time delay product mixer safety cover interlock switch is mounted in the motor compartment. **The product mixer safety cover cannot be opened until the time delay interlock switch times out (which will be after the grinding auger comes to a complete stop).**
11. With the grinding auger removed from the machine, push the green start button for grind. **CHECK THE ROTATION of THE AUGER DRIVE SHAFT; ROTATION MUST BE COUNTER-CLOCKWISE** as indicated by the rotation decal affixed to the grinding bowl. **ROTATION MUST ONLY BE CHECKED WITH THE GRINDING AUGER REMOVED**, otherwise serious irreparable damage may occur to the grinding components.



12. If machine runs clockwise(backwards), it must be rewired to correct rotation, otherwise serious irreparable damage may occur to the grinding components. The grinding auger must operate in the proper direction.
13. Check operation of optional footswitch if equipped. Plug footswitch cord into fitting at bottom of contactor box. Turn toggle selector to foot. The machine will operate with pressure on the footswitch treadle. Releasing the treadle stops the machine. The footswitch operates both the mix and grind together.
14. Insert grinding auger assembly into the bowl and fully engage the auger into the drive shaft. Place knife first (sharp edges out) then grinding plate into end of grinding bowl. The grinding plate slides over the knife drive pin, and is held from rotating during operation by three pins in the grinding bowl. Install the end retaining ring.



ONLY HAND TIGHTEN END RETAINING RING

For best results, use knife and plate as a set. Do not operate machine for any period of time without product in the grinding bowl. This will cause heating and dulling of the knife and plate.

15. Check placement of all warning labels and Manual. Machine is now ready for trained operators to process product.
16. Use meat deflector attached to grinding bowl to eliminate meat splatter.
17. Contact your local Distributor or BIRO directly if you have any questions or problems with the installation or operation of this machine.

OPERATION

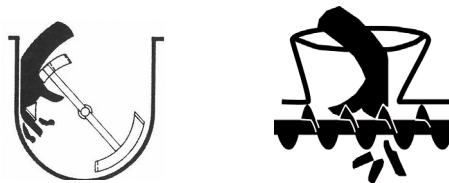

TO AVOID SERIOUS PERSONAL INJURY

- **ONLY** Properly Trained Personnel Should Use This Equipment.
- **NEVER** Place Hands into Machine Input or Output Openings.

OPERATION (Continued)

- **NEVER** Open Machine During Operation.
- **DO NOT** Wear Gloves While Operating.
- **DO NOT** Tamper With, Bypass, Alter, or Modify This Equipment in Any Way From Its Original Condition.
- **NEVER** Operate Machine With Product Mixer Safety Cover Open or Removed or Magnetic Interlock Switch By-Passed.
- **ALWAYS** Turn Off, Unplug Machine From Power Source and Perform Lockout/Tagout Procedure to this Machine **BEFORE** Attempting to Unjam or Unclog, Cleaning or Servicing.
- **NEVER** Leave Machine Unattended While the Grinder is Running.
- **NEVER** Operate Without all Warning Labels Attached and Owner/Operator Manual Available to the Operator.

DO's

- Always keep knife & plate as matched set.
- Always keep the knife & plate sharp.
- Always check for straightness by laying the knife on the plate before inserting in machine.
- Always install the knife & plate in correct sequence, knife 1st, then plate.
- Always keep knives & plates lubricated in storage and when starting machine.
- Always use coolant when sharpening plates.
- Always inspect the plates making sure all holes are clear - that there are no cracks.

DONT's

- Never, never mix different knives to different plates.
- Never, never over tighten the bowl retaining ring on the machine.
- Never, never run the grinder without product. Product is a natural lubricant. Heat can build up so fast that cold product could crack the plate.
- Never, never hit the plate against anything to clean the holes.
- Never, never throw the knives & plates.

FOOD HANDLING TO PREVENT CONTAMINATION

1. **ALWAYS** wash hands thoroughly with warm soap and water before and after handling raw fish, poultry or meats.
2. **ALWAYS** clean and sanitize all utensils and surfaces that have been in contact with raw products.
3. **ALWAYS** store cold foods at or below 45° F (7.2 ° C).

TO PROCESS PRODUCT

1. Before starting the mixer-grinder, have a container for receiving ground product at the output end of the grinding bowl.
2. **FIRST GRIND**
 - a. Fill product hopper (maximum 150 pounds), close product mixer safety cover.
 - b. Push both grind and mix green start buttons to feed first grind. It is recommended to use a breaker plate with a 3/8" diameter or larger holes.
 - c. Push both grind and mix red stop buttons when product has been ground out.
3. **SECOND GRIND**
 - a. Fill product hopper (maximum 150 pounds). Before this mix operation seasonings may be added if desired. Close product mixer safety cover.
 - b. Push the mix green start button only.
 - c. After the desired mix, press green grinder start button to operate the grinding auger and grind out the product.
 - d. Push both grind and mix red stop buttons when product has been ground out.
4. Unplug machine from power source and perform lockout/tagout procedures.

MAINTENANCE



ROTATING GRINDING AUGER

TO AVOID SERIOUS PERSONAL INJURY

- **ALWAYS** Turn Off, Unplug Machine From Power Source and Perform Lockout/Tagout Procedure to this Machine **BEFORE** Attempting to Unjam or Unclog, Cleaning or Servicing.
- **NEVER** Touch This Machine without Training and Authorization by Your Supervisor.
- **NEVER** Place Hands into Machine Input or Output Openings.
- **NEVER** Bypass, Alter, or Modify This Equipment in Any Way From Its Original Condition.
- **PROMPTLY REPLACE** Any Worn or Illegible Warning Labels.
- **USE ONLY GENUINE BIRO** Parts and Accessories Properly Installed.

A. GRINDING BOWL INSTALLATION

1. Mount the grinding bowl on the two threaded studs on the front of the machine. Tighten in position with provided nuts.
2. Place the grinding auger in the grinding bowl and fully seat rear drive tang into auger drive shaft.
3. Install knife, breaker plate, and end retaining ring.



ONLY HAND TIGHTEN RETAINING RING

4. When the bowl assembly is mounted and tight, there should be approximately 1/8" gap between the back inside wall of the grinding trough and the back of the auger. The bowl ring wrench which is provided with each grinder is used for **REMOVAL** of the end retaining ring for cleaning purposes or for changing knife and breaker plate.

B. LUBRICATION

1. **MOTOR:** The grinder motor has pre-lubricated, sealed motor bearings.
2. **ROLLER CHAIN AND DRIVE SPROCKETS:** The main drive chain has been pre-lubricated at the factory to protect it against dirt and moisture. Chain life will vary appreciably depending upon lubrication. The better the lubrication, the longer the chain life.

Lubrication effectiveness will vary with the amount of lubricant and frequency of application. Ideally, a lubricant film should always be present between the working parts. Manually lubricate the chain as often **as is needed** (possibly once a week). **NEVER** exceed three months without lubricating.

Lubricating just the outside of the chain does little good. Apply lubrication on the inside of the chain span so that it will work through the moving parts and joints by centrifugal force as the chain rotates and reaches the area where one surface "scrubs" another.

B. LUBRICATION continued

Recommended types of chain lubricant are those with Molybdenum Disulphide or Graphite added. Also bonded lubricants such as Dow Corning Molykote 321R or equivalent are excellent for open chains. The lubricant should be of a viscosity whereby it will “flow” somewhat and penetrate the internal working surfaces. Thick stiff greases are of little value because they cannot work into moving parts of the chain.

- a. Unplug mixer/grinder from power source and perform lockout/tagout procedures.
 - b. Remove rear drive or access cover.
 - c. Spray or brush lubricant on inside of chain, slowly and carefully turning the large sprocket by hand.
 - d. Reinstall rear drive cover.
3. BEARING HOUSING: The main bearings are housed in an enclosed and sealed journal box. Re-lubricate semi-annually with a good grade of bearing grease. Do not over-grease.
4. MIXER TRANSMISSION: Oil in the mixer transmission should be changed after the first four (4) weeks of operation. This is to remove the “run-in” oil and also any small metal shavings that may have been generated during the mating of the gears. After the initial oil change, subsequent changes should be performed every six (6) months. After draining the oil, refill the unit to the “level” plug on the back side of the transmission with petroleum-based #8 gear oil.
5. PROCEDURE FOR REPLACING OIL IN WINSMITH MIXER TRANSMISSION:
- a. Unplug mixer/grinder from power source and perform lockout/tagout procedures.
 - b. Remove rear drive or access cover.
 - c. Remove breather plug from top of transmission and oil level plug from back side of transmission.
 - d. With a container in place to catch old oil, remove the drain plug from the bottom of the transmission.
 - e. When all oil has drained, clean the drain plug and replace in the transmission.
 - f. Refill transmission with petroleum-based #8 gear oil or equivalent until oil appears at bottom of oil level hole. For applications that involve severe ambient temperature extremes, Winsmith recommends the use of Synthetic Lubricants such as: Texaco Vanguard 460, Mobile SHC 630, and Mobile SHC 634. These gear reducers contain 0.9 QT. of lubricant.
 - g. Replace breather and oil level plugs.
 - h. Reinstall rear drive or access cover.

C. MIXER DRIVE CHAIN TENSION

1. Unplug mixer/grinder from power source and perform lockout/tagout procedures.
2. Remove rear drive or access cover.
3. Loosen the four bolts holding the $\frac{3}{4}$ HP motor and transmission to its mounting plate.
4. Slide transmission to the right.
5. When approximately $\frac{1}{8}$ ” total chain flex has been attained, retighten transmission bolts.
6. Reinstall rear drive cover or access cover.

D. MAIN DRIVE CHAIN TENSION

1. Unplug mixer/grinder from power source and perform lockout/tagout procedures.
2. Remove rear drive or access cover.
3. Loosen the four bolts that hold the motor to the frame of the machine.
4. Loosen the lock nuts on the motor adjusting stud.
5. **To Loosen Chain Tension.** Turn motor adjusting studs counterclockwise. Grasp motor and pull toward adjusting stud. Be sure to turn both adjusting studs the same amount and evenly. Total chain flex should be $\frac{1}{8}$ to $\frac{3}{8}$ ”. Be sure to keep motor shaft **parallel** with auger drive shaft.

D. MAIN DRIVE CHAIN TENSION (Continued)

To Tighten Chain Tension. Turn motor adjusting studs clockwise. Be sure to turn both adjusting studs the same amount and evenly. Total chain flex should be $\frac{1}{8}$ to $\frac{3}{8}$ ". Do not overtighten chain as this will put excessive and damaging pressure on the motor bearings. Be sure to keep motor shaft **parallel** with auger drive shaft.

6. Retighten motor mounting bolts.
7. Retighten motor adjusting stud lock nuts.
8. Reinstall rear drive cover or access cover.

- OPERATOR'S NOTES -

OPTIONAL EAGLE BELT DRIVE SYSTEM

FORCE TABLE #1-7

<p>7-1/2 HP (5.6 kw) new 15.3 lb (6.9 Kg) used 11.2 lb (5.1 Kg)</p>

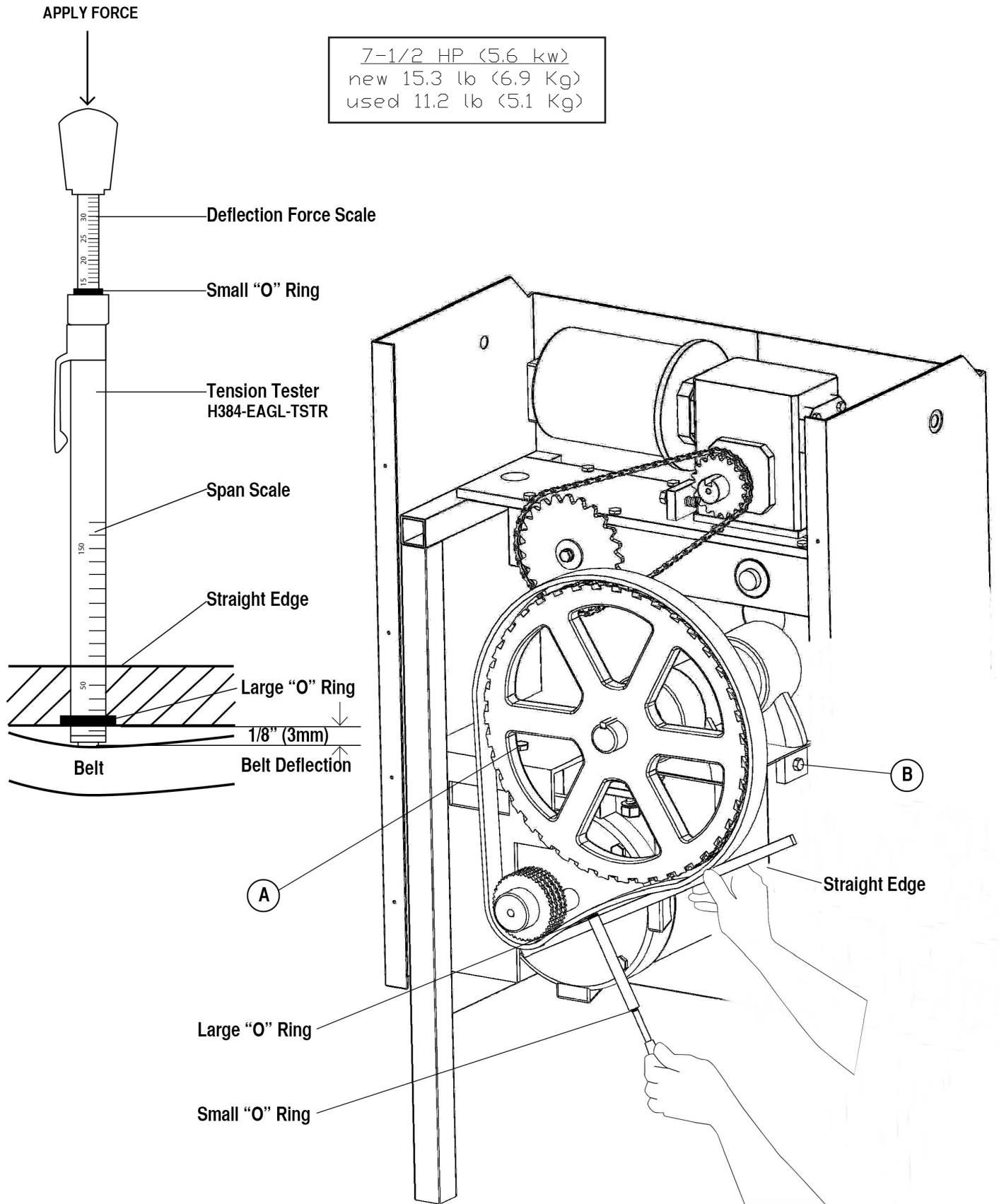

“EAGLE” DRIVE SYSTEM

Tensioning Instructions

1. Place a straight edge on top of the belt and across both sprockets as shown in the diagram.
2. Set the large O-Ring at the 1st Graduation ($\frac{1}{8}$ ” line) on the Tension Tester, Item No. [H384-EAGL-TSTR](#).
3. Set the small O-Ring on the deflection force scale to ZERO.
4. Place the tension tester squarely on the belt at the center of the belt span (see Diagram).
5. Apply a force to the plunger until the large O-Ring is even with the bottom of the straight edge which has been laced across both sprockets ($\frac{1}{8}$ ” belt deflection).
6. Remove the tension tester and read the force recorded from the bottom of the small O-Ring on the force scale.
7. The force should be equal to the value indicated in the force table #1-7 depending on the “HP” of the grinder, and if the belt is “new” or “used.”
8. If the force values do not equal those shown in table #1-7, increase the tension as follows:
 - a. Loosen the 4 motor mounting bolts (A) slightly.
 - b. Advance the jacking screw (B) $\frac{1}{4}$ turn each (be sure to advance both screws an **equal** amount).
 - c. Retighten the motor mounting bolts.
 - d. Re-check the belt tension according to the above procedure.

Do not rely on “feel” for the proper belt tension as this typically results in belts that are under-tensioned.

Loose belts will fail due to “ratcheting” (jumping a tooth), tooth shearing, and breakage.

- OPERATOR'S NOTES -

INSTALLATION INSTRUCTIONS

ALTERNATE GROVE GEAR REDUCER

REPLACING MORSE GEAR REDUCER

Mixer Paddle Gear Reducer Retro-Fit

Effective with Model EMG-32; Serial No. 6988, April 2007

The Mixing Paddle Gear Reducer, Item No. EMG20301 (Winsmith) has been replaced with an alternate Gear Reducer, Item No. [EMG20301G](#) (Grove)

If an old style Winsmith Gear Reducer, #EMG20301, should need replacing, a “Retrofit Kit” will be supplied incorporating the new Grove Reducer, Item No. [EMG20301G](#) (see drawing):

Procedure for EMG-32 Gear Reducer

Replacement:

Perform lockout/tagout on the power supply.

Disconnect wiring from the mixer motor.

Loosen check nut, Item No. [HN30S](#) and back out adjuster bolt, Item No. [HHS093S](#).

Loosen four (4) reducer mounting bolts.

Slide the unit to the left and remove the chain.

Loosen and remove sprocket, Item No. [EMG62012](#)

and Key, Item No. [EMG62197](#) from the reducer.

Remove the reducer mounting bolts and take the motor/reducer unit from the machine.

Remove the motor from the reducer and the motor key from the reducer.

New reducer will arrive with the adaptor plate, Item No. [EMG62020G](#) installed on the reducer from the factory with two (2) $\frac{3}{8}$ -16 x 1 flat head screws, Item No. [FHS58S](#).

Install mixer motor and key onto the new reducer with the original hardware. Remove fill plug in top hole,

backside of reducer, and install vent plug supplied

with the gear box. Install sprocket with key on the reducer. Set the unit on the machine. Use two (2) $\frac{3}{8}$ -16 x 1½ long bolts, Item No. [HHS080S](#) with two (2) $\frac{3}{8}$ lock washers, Item No. [LW20S](#), two (2) flat washers, Item No. [FW083S](#) and two (2) spacers bushings, Item No. [EMG20302](#) in the two holes closest to the chain and sprocket.

Use two (2) $\frac{3}{8}$ -16 x 1 long bolts, Item No. [HHS070S](#) with two (2) $\frac{3}{8}$ lock washers, Item No. [LW20S](#), two (2) flat washers, Item No. [FW083S](#) and two (2) spacers, Item No. [EMG20302](#) in the two holes away from the chain and sprocket.

Mount chain on reducer sprocket. Use adjusting bolt to set chain tension to $\frac{1}{8}$ ” total flex.

Tighten the four (4) mounting bolts on the reducer. Check the sprocket alignment and tighten set screws.

Install electrical supply to mixer motor. Test for proper operation and rotation synchronization with the auger.

Install the rear cover.

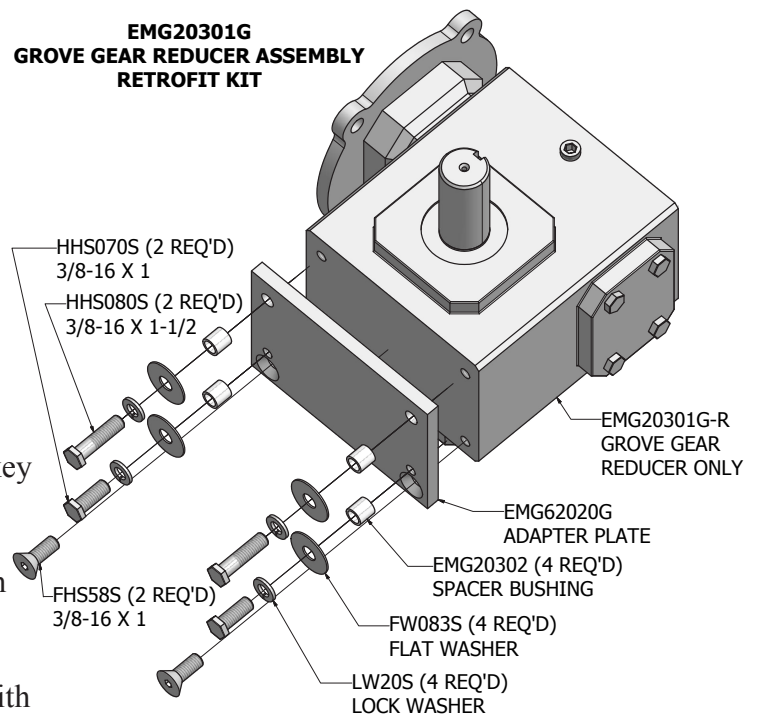

LUBRICATION FOR GROVE GEAR REDUCER

1. Factory Filling

The speed reducers are oil filled at the factory to the proper level for the standard mounting position. The oil level should be checked and adjusted (if necessary) prior to operation, using the oil level plug provided and while the unit is oriented in its operating position.

2. Oil Changing



**WHEN CHANGING OIL FOR ANY REASON,
DO NOT MIX DIFFERENT OILS IN THE REDUCER.
OILS SHOULD BE COMPATIBLE WITH
VITON® SEAL MATERIAL.**

Therefore, when changing to a different oil, it is recommended that the housing be completely drained and thoroughly flushed with a light flushing oil prior to refilling with the appropriate lubricant. The oil level should be rechecked after a short period of operation and adjusted, if necessary.



**OIL SHOULD BE CHANGED MORE OFTEN IF THE
REDUCER IS USED IN A SEVERE ENVIRONMENT
(i.e., DUSTY, HUMID)**

A. Initial Oil Change

The oil in a new speed reducer should be changed at the end of 250 hours of operation. (30 days for 8 hour per day service, 15 days for 16 hour service, 10 days for 24 hour service.)

All standard reducers ordered from the factory are filled with lubricant to operate within a 30° to 100° F ambient temperature range.

B. Subsequent Oil Changes

Under normal conditions, after the initial oil change, the oil should be changed after every 2500 hours of operation, or every six months, whichever occurs first. Under severe conditions (rapid temperature changes, moist, dirty, or corrosive environment) it may be necessary to change oil at intervals of one to three months. Periodic examination of oil samples taken from the unit will help establish the appropriate interval.

C. Synthetic Oils

Synthetic lubricants can be advantageous over mineral oils in that they generally are more stable, have a longer life, and operate over a wider temperature range. These oils are appropriate for any application but are especially useful when units are subjected to low start-up temperatures or high operating temperatures. Use of synthetics can cause problems if they are not compatible with the seals or the conventional lubricants they replace. For continuous duty at normal ambient temperatures (-10° to 105°F) we recommend the use of Mobile SHC 634 which is compatible with the standard compounded oil shipped in our product and the Viton® seal material used through size 252.

3. Overfilling or Underfilling

If a speed reducer is overfilled with oil, the energy in churning the excessive oil can result in overheating. If this occurs, shut down the drive, remove the oil level plug and allow oil to drain until oil ceases to drain from the level hole, reinstall the oil level plug and restart the drive. If the speed reducer is underfilled, the resultant friction can cause overheating and possible damage. If this occurs, fill the speed reducer to the oil level plug hole and check the gearing for excessive wear. NOTE: Oil capacity is 1¾ pints.

4. Oil Seals

Although the speed reducer uses high quality oil seals and precision ground shafts to provide a superior seal contact surface, it is possible that circumstances beyond the speed reducer's control can cause oil seal leakage (damage during shipment or installation, etc.) When replacing a shaft oil seal, using the following suggestions will help to insure leak-free operation and long seal life:

A. When installing a new seal, cover the keyway and any other surface discontinuity with smooth tape to protect the seal lip from being damaged.

B. A sealant should be used between the O.D. of the seal and the I.D. of the bore into which the seal is installed. The seal bore should also be free of any burrs, nicks, or scratches.

C. Be sure that the seal is not cocked in the bore. The outer face of the seal should be flush with the surface into which it is mounted.

**EMG20301G-R GROVE GEAR REDUCER
LUBRICATION AND MAINTENANCE
AFTER SERIAL No. 6987**

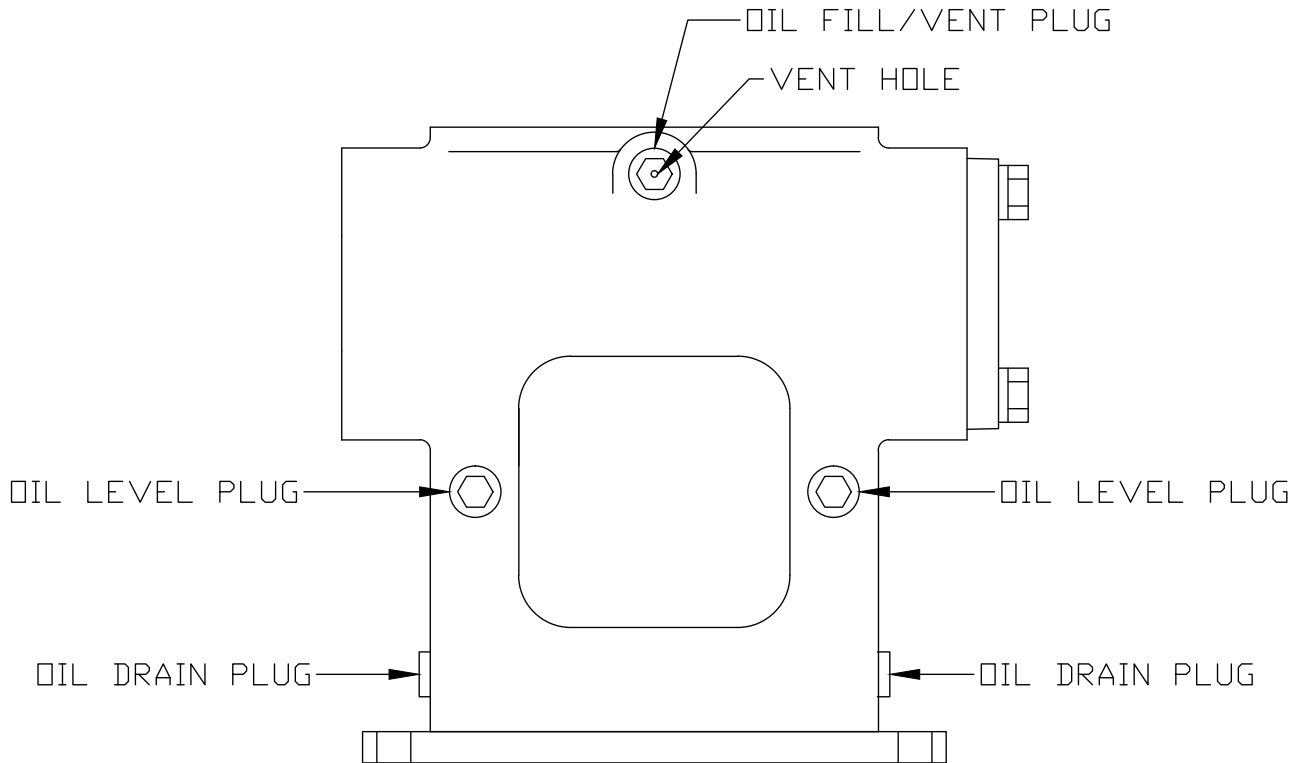

LUBRICANTS FOR EMG20301G-R GROVE GEAR WORM REDUCER

The precision-made gears and bearings in Grove Gear Speed Reducers require high-grade lubricants of the proper viscosity to maintain trouble-free performance. For best results, use lubricants on the following chart for worm gear reducers.

Manufacturer	30° to 100°F Ambient Temperature AGMA Compounded No. 7	50° to 125°F Ambient Temperature AGMA Compounded No. 8
Amoco Oil Co.	Worm Gear Oil	Cylinder Oil #680
Chevron USA, Inc.	Cylinder Oil #460X	Cylinder Oil #680X
Exxon Co. USA	Cyclesstic TK-460	Cyclesstic TK-680
Gulf Oil Co.	Senate 460	Senate 460D
Mobile Oil Corp.	600 W Super Cylinder	Extra Hecla Super
Shell Oil Co.	Valvata Oil J460	Valvata Oil J680
Sun Oil Co.	Gear Oil 7C	Gear Oil 8C
Texaco	Honor Cylinder Oil	650T Cylinder Oil
Union Oil Co. of CA	Steaval A	Worm Gear Lube 140

Standard factory-installed lubricant is Mobile Oil Corp. 600 W Super Cylinder Oil (AGMA7).

Some gear lubricants contain E.P. additives that can be corrosive to gear bronze material. Avoid lubricants that are compounded with sulfur and/or chlorine.

#53953, MIXER DRIVE SHAFT SEAL REPLACEMENT

1. Clean the inside of the groove of the mixer drive shaft seal and mating contact surface of the tub wall thoroughly with scotch-bright or a roughing pad.
2. Dispense a small amount of #454 Loctite adhesive to both these areas - assure even coverage.
3. Wipe away excess adhesive.
4. Slide the “Pressing Rings” #ST90 and #ST91 over the ends of the mixer drive shaft.
5. Apply “even” pressure to the Rings by installing the paddles and Bearing End Assemblies.
6. Wait 20 minutes Cure-Time.
7. Remove the “Pressing Rings.” The seals will be firmly attached to the tub wall.

NOTE: Part Number for 454 Loctite is #53953A-1

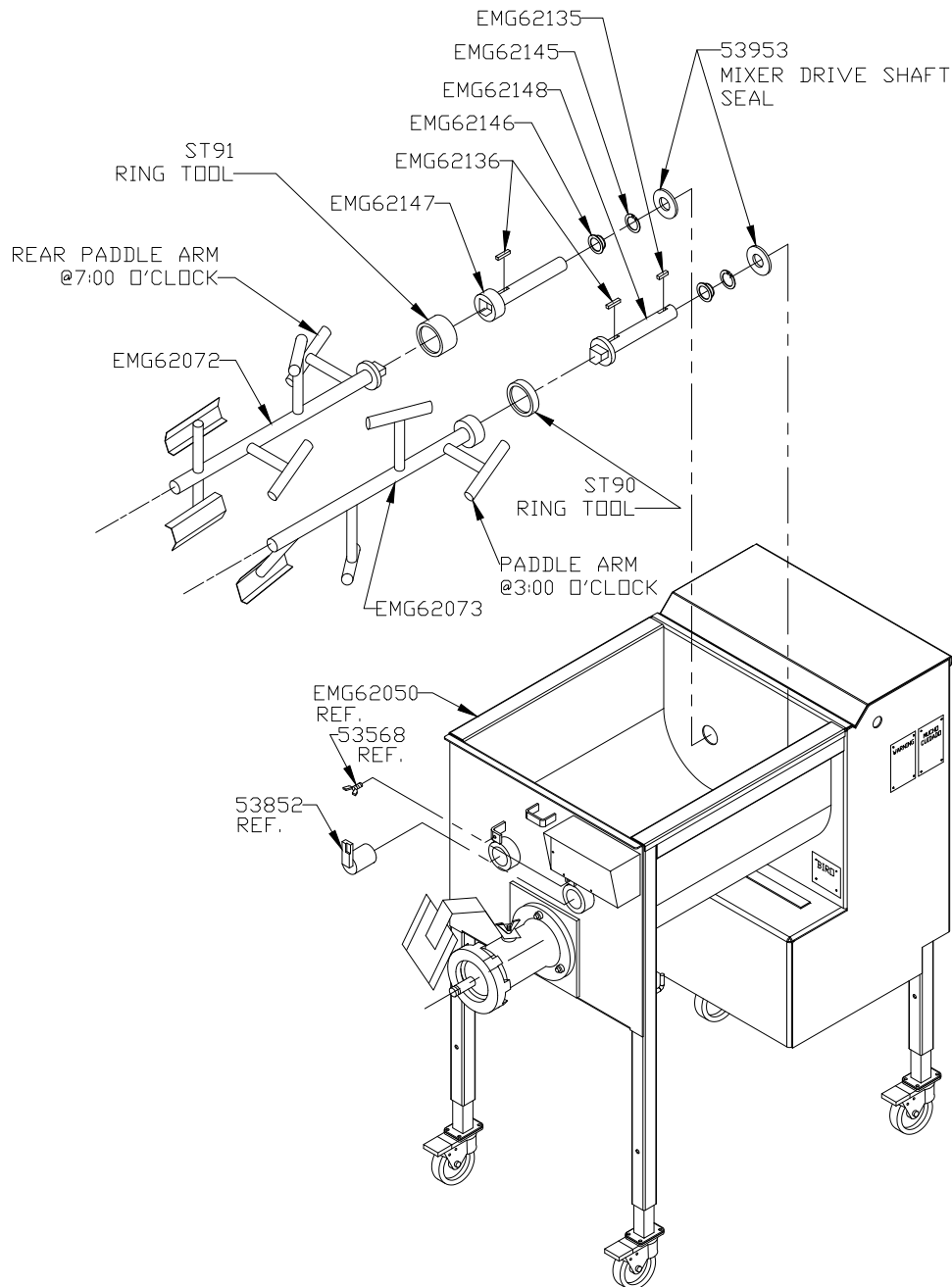



CLEANING



TO AVOID SERIOUS PERSONAL INJURY

- **ALWAYS** Turn Off, Unplug Machine From Power Source and Perform Lockout/Tagout Procedure to this Machine **BEFORE** Attempting to Unjam or Unclog, Cleaning or Servicing.
- **ONLY** Use Recommended Cleaning Equipment, Materials, and Procedures.
- **NEVER** Spray Water or Other Liquid Substances Directly at Motor, Power Switch or any Other Electrical Components.
- **ALWAYS** Thoroughly Clean Equipment at Least Daily.

CLEANING THE EMG-32 MIXER-GRINDER

1. Disconnect mixer grinder from power-source and perform lockout/tagout procedures.
2. Remove grinding bowl end ring, breaker plate, knife and grinding auger.
3. Remove mixing paddles by first loosening the wing nuts locking the mixing paddle from hubs. Turn the front hubs clockwise and remove from front of machine. Slide mixing paddles forward off the drive shafts and remove the mixing paddles from the machine.



DO NOT POWER SPRAY DIRECTLY AT ELECTRICAL COMPONENTS

4. Machine is now ready to be cleaned using warm soapy water and rinsed with clean water. Machine may be cleaned by power spray washing, taking care not to spray directly at any electrical controls.
5. The grinding bowl can be removed for cleaning if desired. This is accomplished by removing the three nuts on the flange of the grinding bowl.
6. After machine has been cleaned and allowed to air dry, all exposed metal surfaces should be coated with a good food grade light oil or grease.
7. Never wash the clear product mixer safety cover with any type of abrasive cleaners. Use a soft cloth and warm soapy water only, rinse with clear water, let air dry.
8. **CLEANING PROCEDURE FOR THE POLYCARBONATE SAFETY COVER:**
 - By using compatible cleaners, coupled with proper maintenance techniques will significantly improve the material's service life.
 - A. Rinse with water to remove excess dust and dirt.
 - B. Wash with soap or mild detergent using a sponge or soft cloth.
 - C. Rinse thoroughly with clean water.
 - D. Dry with a soft cloth or chamois to prevent water spots.

COMPATIBLE CLEANERS: Formula 409, Palmolive liquid - 3, Tob Job, Joy - 2, Windex with Ammonia D-4.

1. Do not use abrasive cleaning materials, such as brillo pads or metal scrapers. Tin is a soft metal and should be cleaned with a soft cloth and dried.
2. Do not use a cleaning agent containing a high percentage of free alkali or acid.
3. Do not use a detergent containing a high percentage of tri-sodium phosphate or meta-silicate. Tin is reactive to both.
4. Rinse well and dry thoroughly after washing to remove agents that may be reactive to tin.
5. If sterilizing agent containing chlorine is used, the tinned surface must be thoroughly rinsed. Chlorine is corrosive to tin.
6. Dry thoroughly after rinsing and store in a dry environment.
7. If water is exceptionally hard, drying will be necessary to prevent spotting.

MIXING PADDLE INSTALLATION

S/N's 6001 to 6057

The Mixing Paddles **ARE NOT INTER-CHANGEABLE**, however they are timed to allow for proper mix action.

PADDLE INSTALLATION:

Install the corresponding mixer paddles by matching the male and female hub drives with the respective female and male paddle hubs.

Reinstall the paddle lock arms and tighten the locking wing bolts.

PADDLE REMOVAL:

Removing mixing paddles by first loosening the paddle lock knobs (wing bolts located on front of the machine). Then turn the lock arms clockwise approx. $\frac{1}{4}$ turn to unlock the paddle shafts and remove them from the hopper.

PADDLE SHAFTS ARE INSTALLED CORRECTLY WHEN
REARMOST PADDLE ARMS FACE
DIRECTIONS AS SHOWN

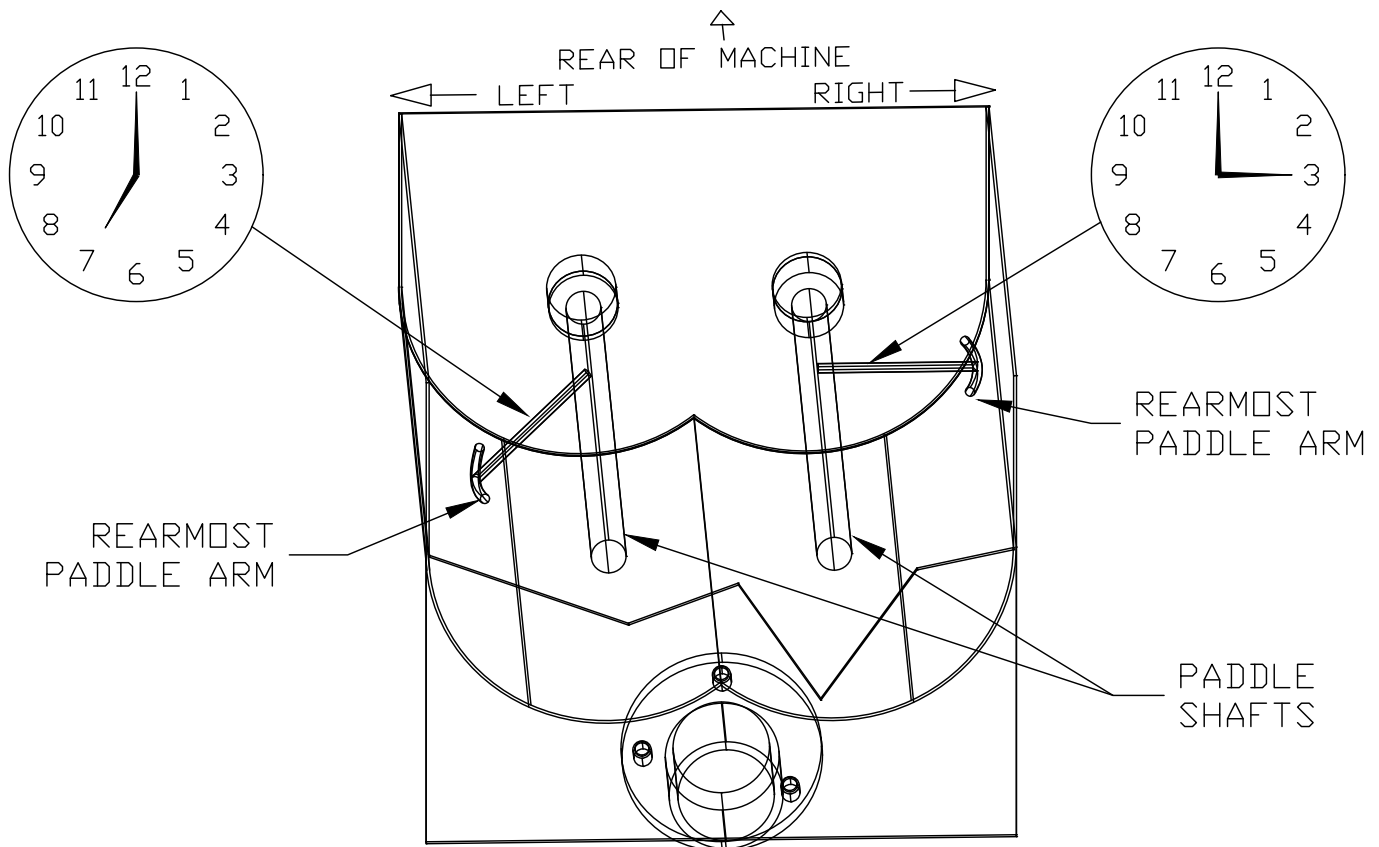

MIXING PADDLE HISTORY BY SERIAL NUMBER

CURRENT STYLE
S/N 6075 TO PRESENT
(5-SIDED COUPLINGS)
(FRONT VEE-BLADES)

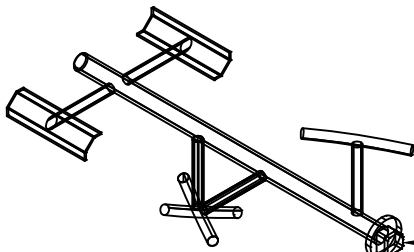

EMG62072
MALE PADDLE,
LEFT HAND

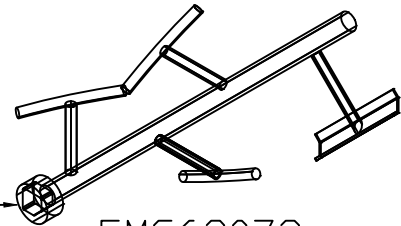
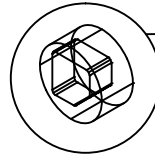
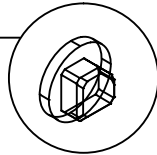

EMG62073
FEMALE PADDLE,
RIGHT HAND

S/N 6066 TO 6074
(4-SIDED COUPLINGS WITH
ALIGNMENT PINS)
FRONT VEE-BLADES

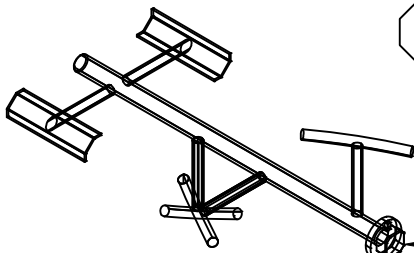

EMG62072-03

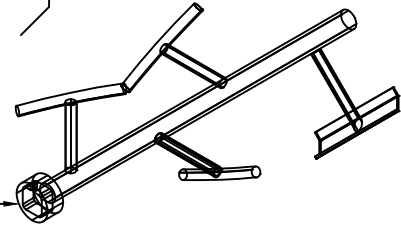
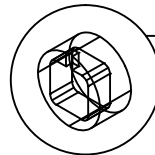
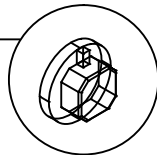

EMG62073-03

S/N 6026 TO 6065 EXCEPT 6057

(4-SIDED COUPLINGS LESS ALIGNMENT PINS,
FRONT FLAT BLADES, CAN BE USED INSTEAD
OF PADDLES FROM S/N 6001 TO 6026)

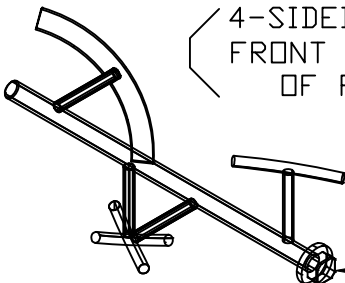

EMG62072-02

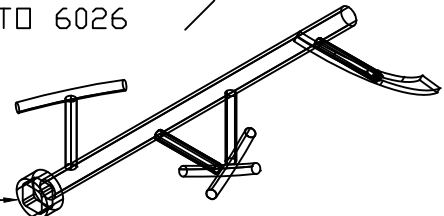
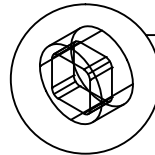
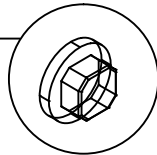

EMG62073-02

S/N 6001 TO 6025

(4-SIDED COUPLINGS LESS
ALIGNMENT PINS)
FRONT ROUND BLADES

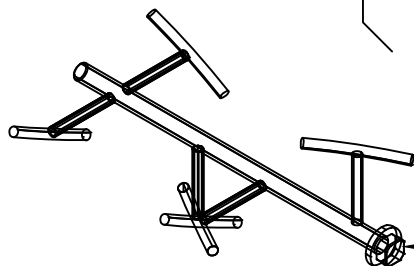

EMG62072-01

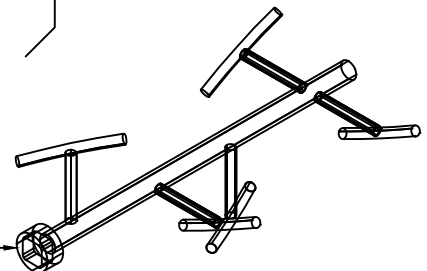
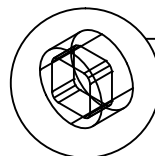
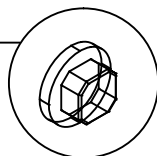

EMG62073-01

ELECTRIC FOOT SWITCH

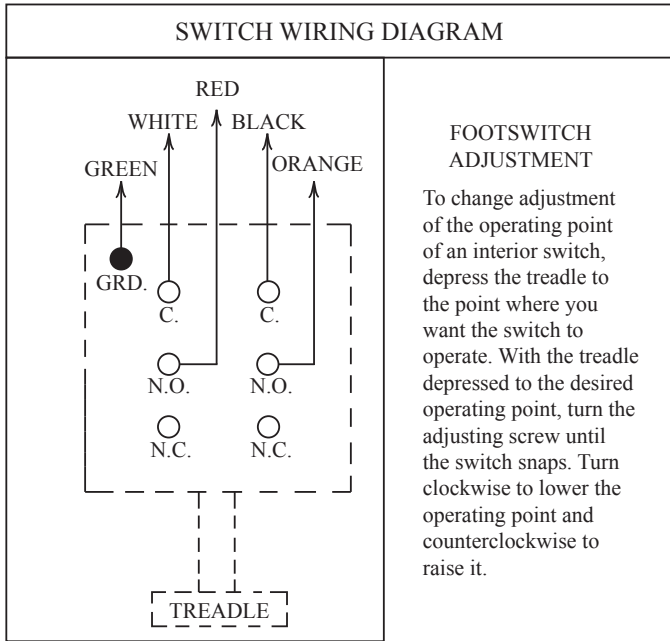

FOOTSWITCH WITHOUT COVER

ALLEN SCREW
NO. (2)

ALLEN SCREW
NO. (1)

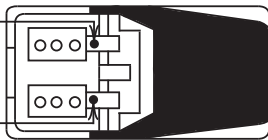

Adjust both
Allen Screws to
activate
Micro-Switches
when the treadle
is in the center
position.

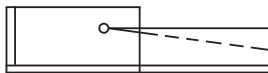

FOOTSWITCH ADJUSTMENT

To change adjustment of the operating point of an interior switch, depress the treadle to the point where you want the switch to operate. With the treadle depressed to the desired operating point, turn the adjusting screw until the switch snaps. Turn clockwise to lower the operating point and counterclockwise to raise it.

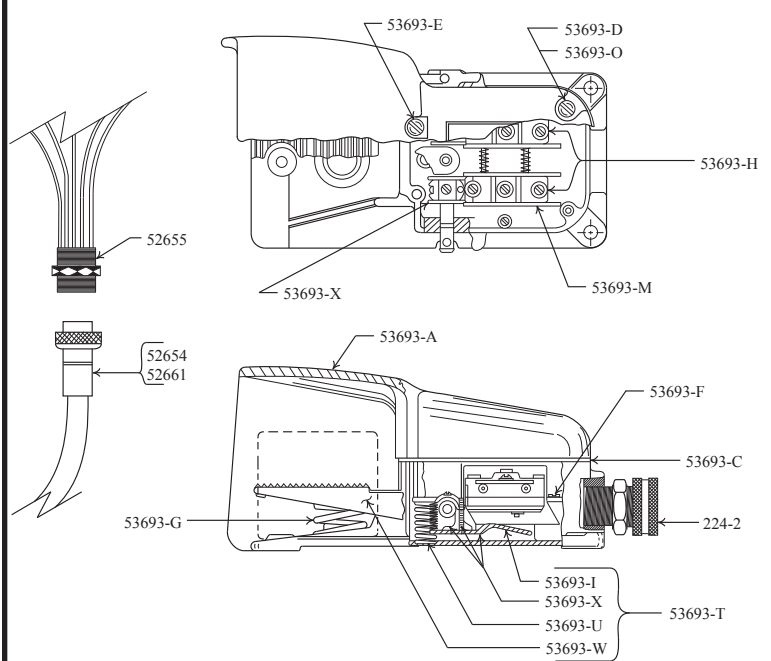

FOOTSWITCH PARTS LIST

- 224-2** Cord connector, wt, straight, 3/4"
- 52654** Male plug w/ 6' cord, 5 wire
- 52655** Female receptacle, 5 pole
- 52661** Male plug w/ 12' cord, 5 wire
- 52668** Footswitch w/ 12' cord and plug
- 53693** Footswitch
- 53693-A** Cover guard
- 53693-C** Cover gasket
- 53693-D** Cover screw- short
- 53693-E** Cover screw- long
- 53693-F** Ground screw
- 53693-G** Treadle spring
- 53693-H** Internal assembly complete
- 53693-I** Actuator
- 53693-M** Micro switch BA2R62-A4
- 53693-O** Washer
- 53693-T** Treadle w/ actuator & return spring
- 53693-U** Auxiliary treadle return spring
- 53693-W** Treadle
- 53693-X** One actuator & actuator spring assembly
- 54213** Footswitch w/6' cord & plug

ELECTRICAL SCHEMATIC EMG-32
 STARTING WITH SERIAL NO 6301-ON
 WITH ELECTRICAL FOOT SWITCH OPTION
 THREE PHASE

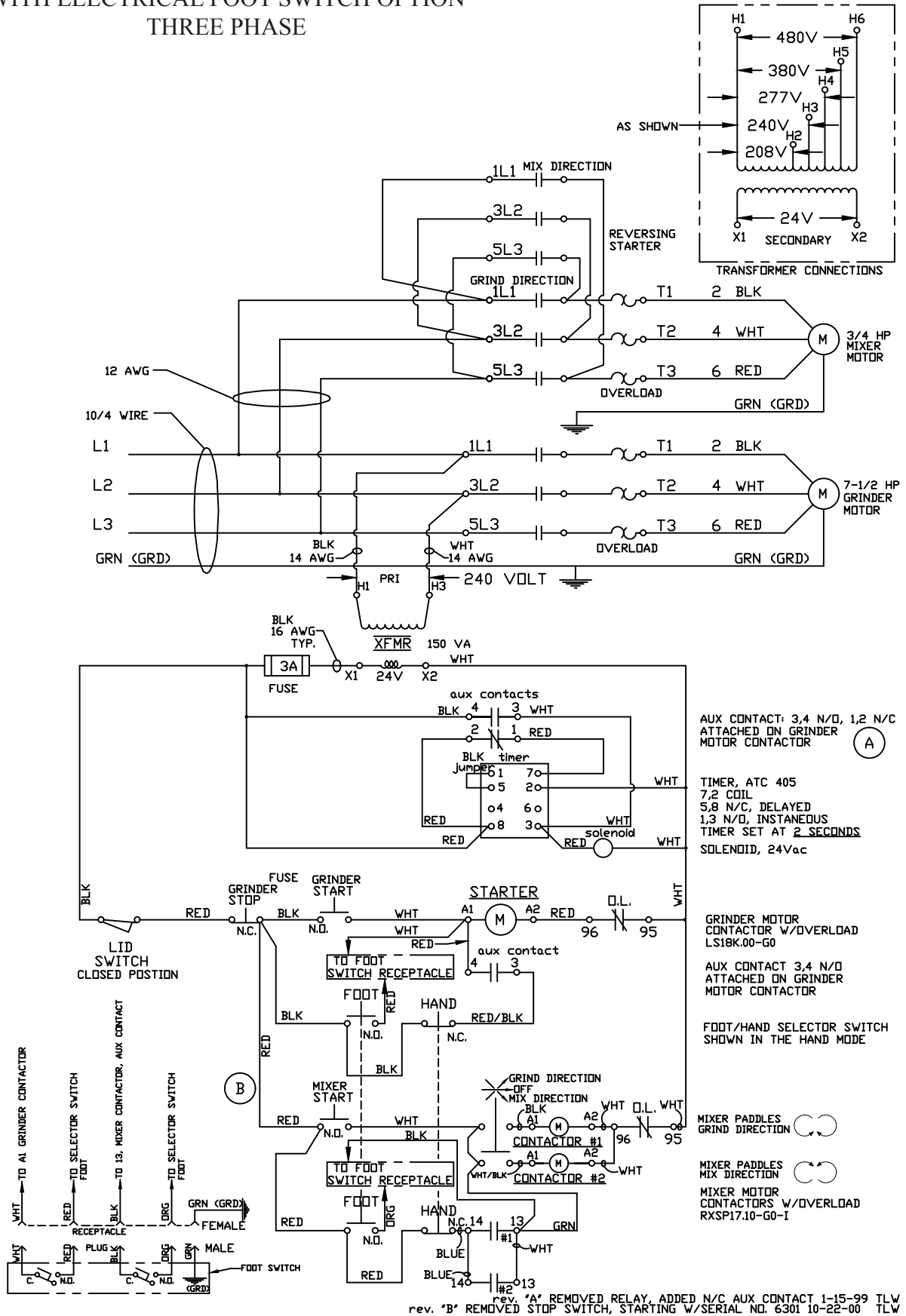

ELECTRICAL SCHEMATIC EMG-32
 STARTING WITH SERIAL NO 6075-6300
 WITH ELECTRICAL FOOT SWITCH OPTION
 THREE PHASE

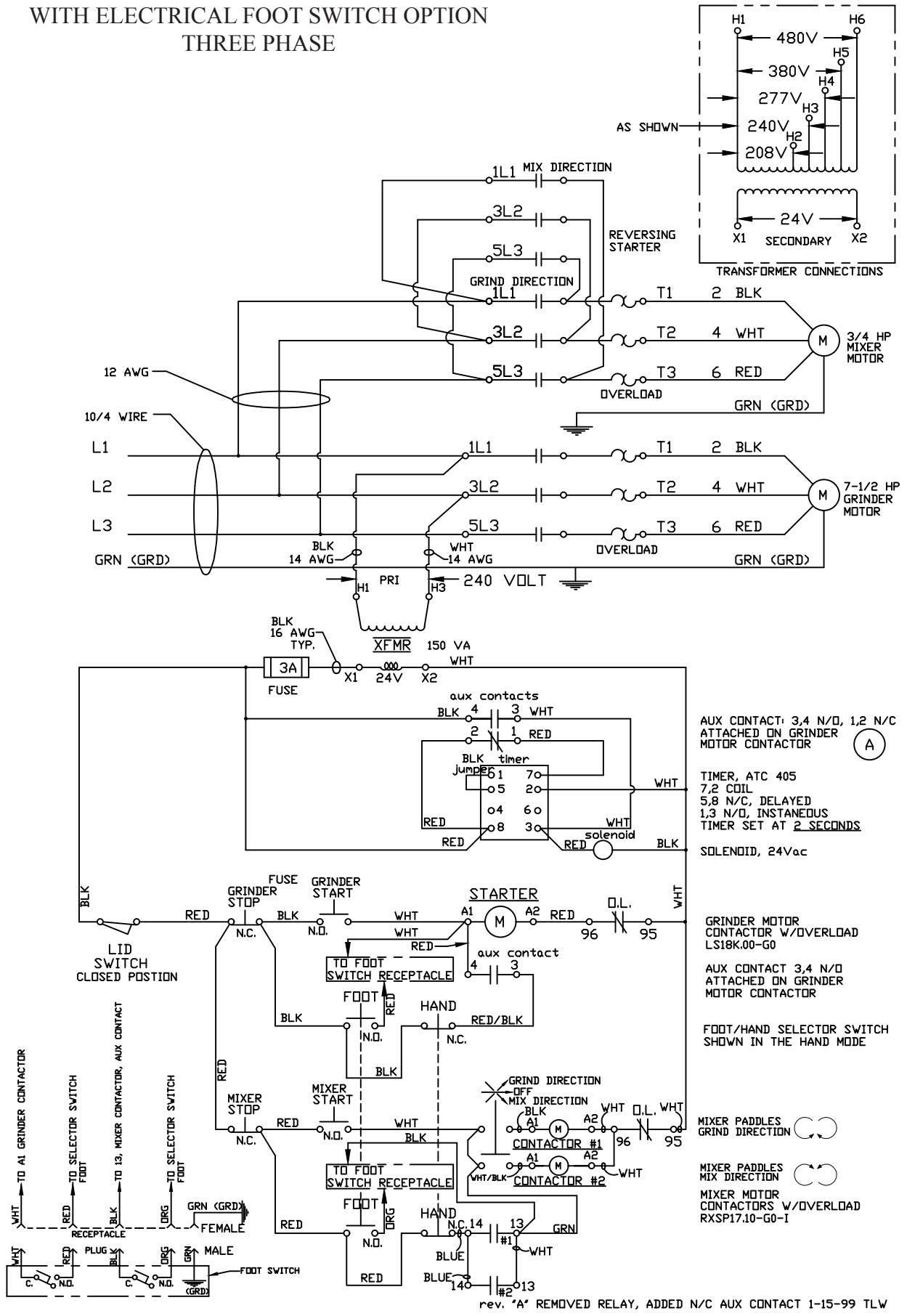

AUX CONTACT: 3,4 N/D, 1,2 N/C
 ATTACHED ON GRINDER
 MOTOR CONTACTOR

TIMER, ATC 405
 7,2 COIL
 5,8 N/C, DELAYED
 1,3 N/D, INSTANEOUS
 TIMER SET AT 2 SECONDS

SOLENOID, 24Vac

GRINDER MOTOR
 CONTACTOR W/OVERLOAD
 LS18K.00-G0

AUX CONTACT 3,4 N/D
 ATTACHED ON GRINDER
 MOTOR CONTACTOR

FOOT/HAND SELECTOR SWITCH
 SHOWN IN THE HAND MODE

MIXER PADDLES
 GRIND DIRECTION

MIXER PADDLES
 MIX DIRECTION

MIXER MOTOR
 CONTACTORS W/OVERLOAD
 RXSP17.10-G0-1

OPTIONAL PNEUMATIC FOOT SWITCH #56304

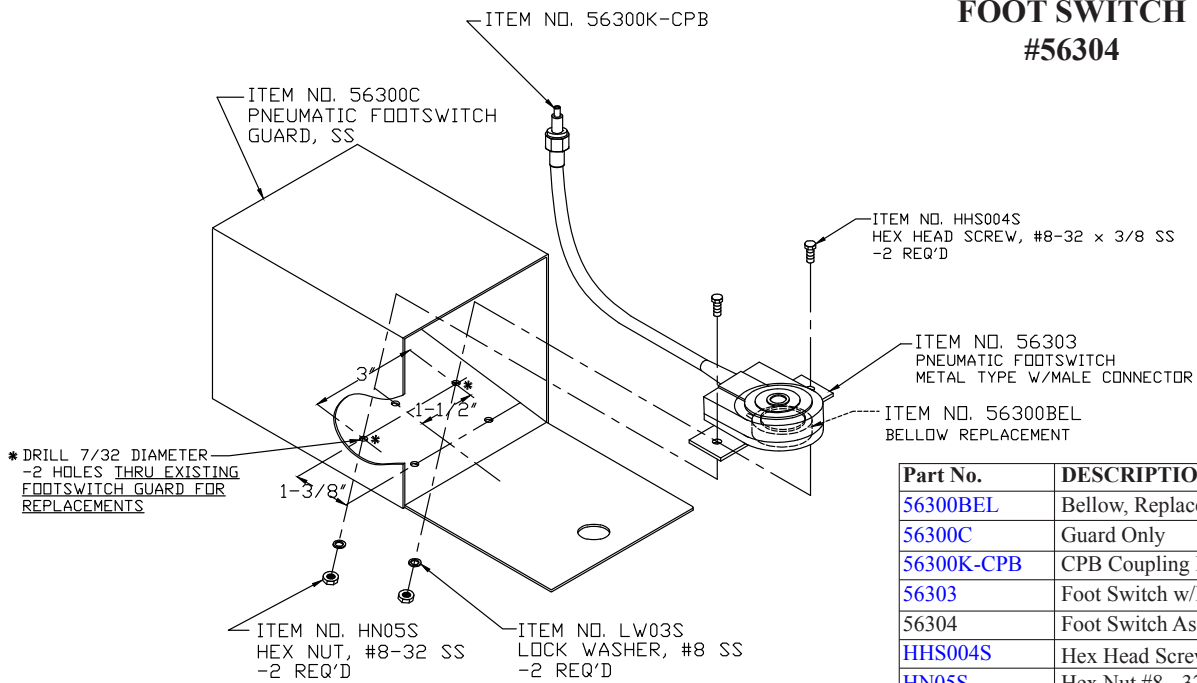

Part No.	DESCRIPTIONS
56300BEL	Bellow, Replacement
56300C	Guard Only
56300K-CPB	CPB Coupling Metal Body-Male
56303	Foot Switch w/Male Coupling
56304	Foot Switch Assembly Complete
HHS004S	Hex Head Screw, #8 - 32 x 3/8
HN05S	Hex Nut #8 - 32
LW03S	Lock Washer #8

PNEUMATIC FOOT SWITCH ASSEMBLY

NEW STYLE PNEUMATIC ASSEMBLY
FROM PUSH BUTTON ENCLOSURE

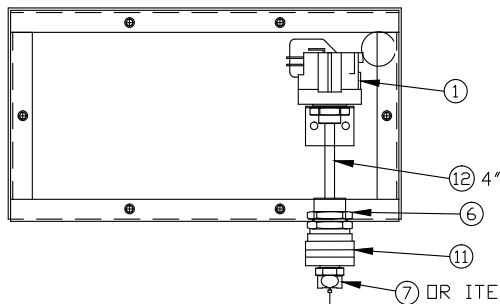

ITEM NO.	PART NO.	PART NAME/DESCRIPTION	QTY
1	56300R	AIR SWITCH W/NUT	1
2	56301E	AIR SWITCH BRACKET	1
3	RHS072S	ROUND HEAD SCREW, #8-32 x 3/8 LG	2
4	HNS05S	HEX NUT, #8-32	2
5	56301G	WATER TIGHT 90° CORD CONNECTOR	1
6	56300H	CORD CONNECTOR LOCKNUT	1
7	56300J	COUPLING BODY, FEMALE -PLASTIC TYPE	1
8	56300K-CPB	COUPLING INSERT, MALE -METAL TYPE	1
9	56304	FOOT SWITCH ASSY W/6' TUBE & GUARD	1
10	LW03S	LOCK WASHER, #8	2
11	224-6	CORD GRIP CONNECTOR, STRAIGHT 1/2	1
12	56302I	PLASTIC TUBING, 1/8 I.D. x 1/4 O.D.	AS SHOWN
13	56303	PNEU. FOOT SWITCH, W/MALE COUPLING	1
14	56300C	GUARD, ONLY	1
15	56300BEL	BELLOW, REPLACEMENT	1

OLD STYLE PNEUMATIC ASSEMBLY
FROM LOWER LEFT
ELECTRICAL ENCLOSURE

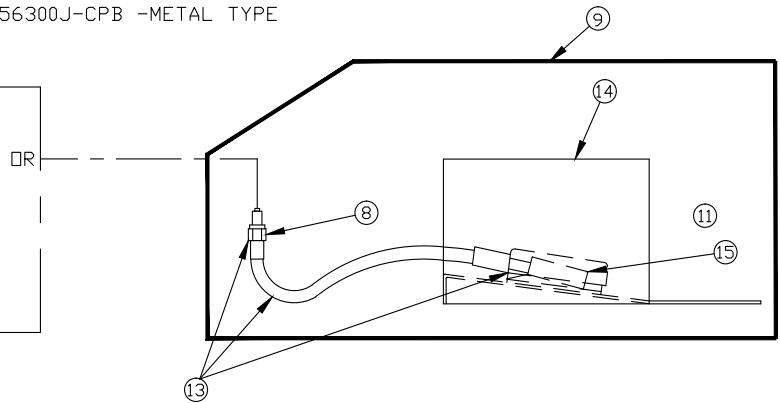
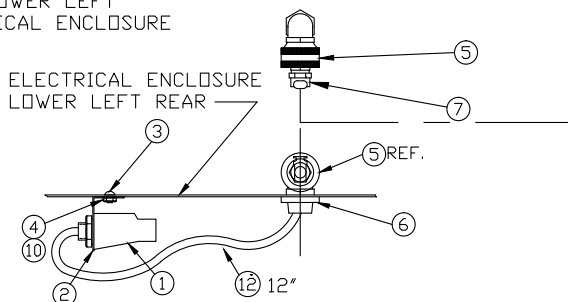

ELECTRICAL SCHEMATIC

STARTING WITH SERIAL No. 6301 - ON

WITH PNEUMATIC FOOT SWITCH OPTION

THREE PHASE

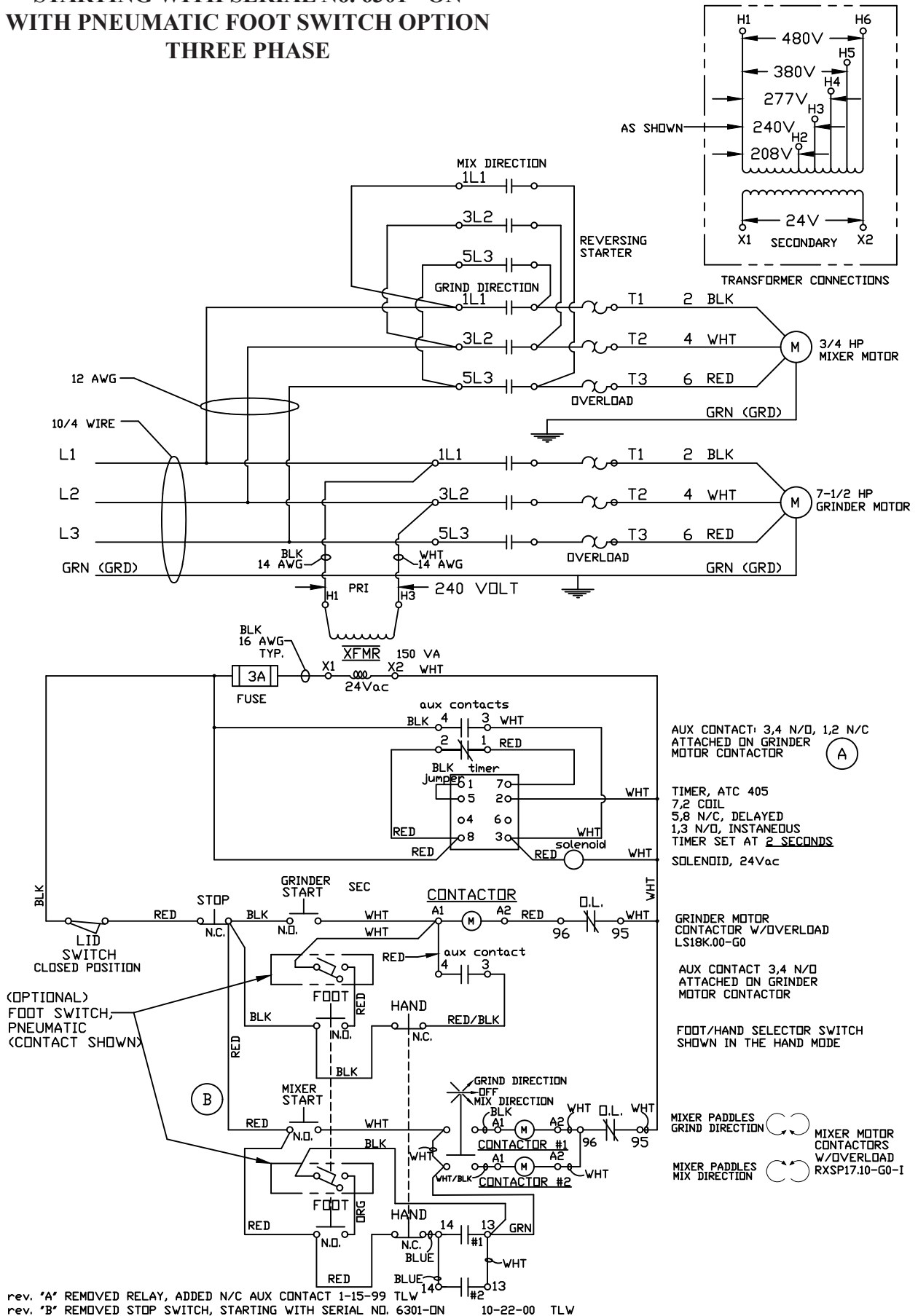

ELECTRICAL SCHEMATIC

STARTING WITH SERIAL No. 6075 - 6300

WITH PNEUMATIC FOOT SWITCH OPTION

THREE PHASE

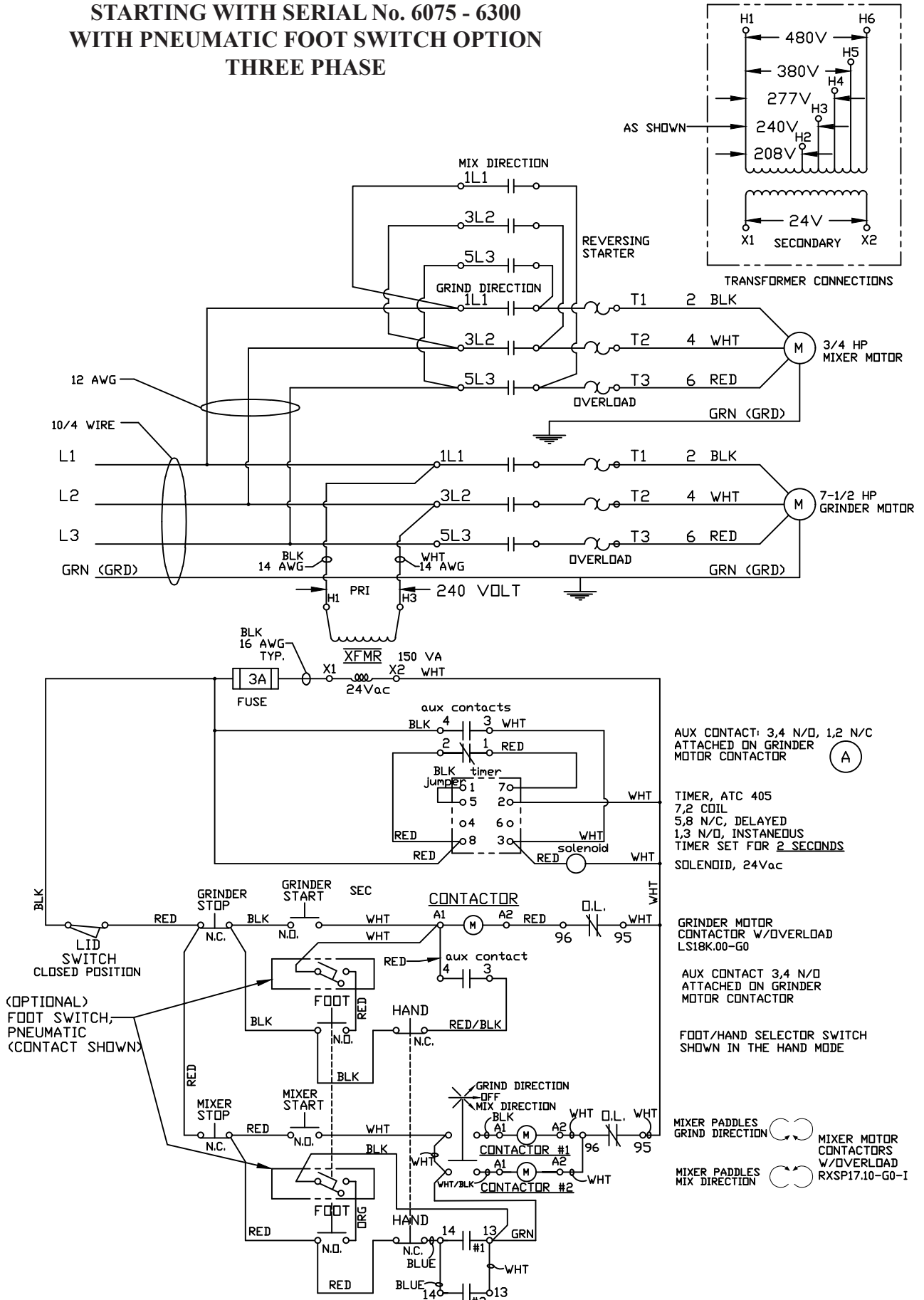

rev. 'A' REMOVED RELAY, ADDED N/C AUX CONTACT 1-15-99 TLW

ELECTRICAL SUBPLATE COMPONENTS

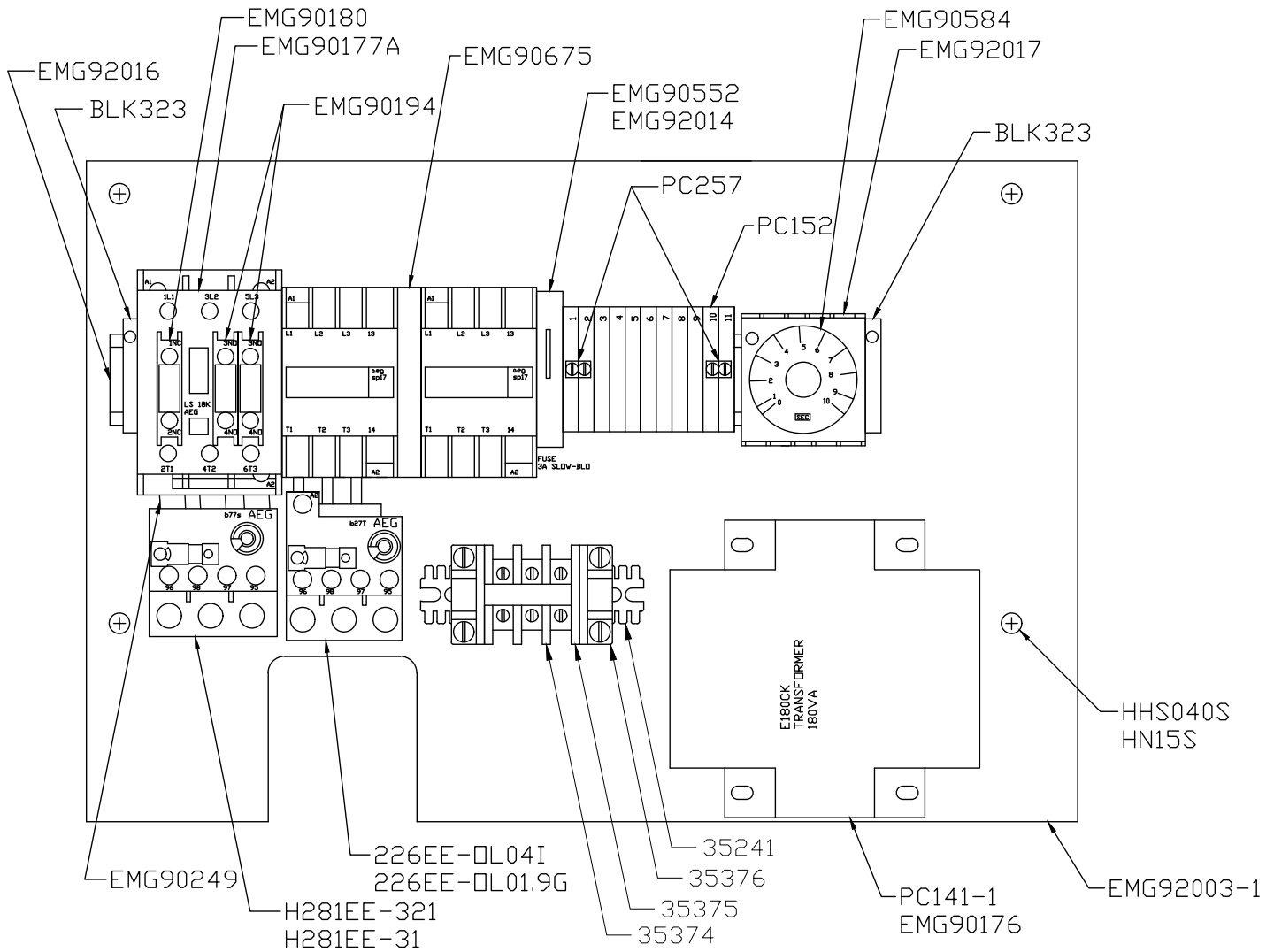

Part No.	Description	Part No.	Description
226EE-OL01.9G	Overload, B18K-G, 1.3-1.9AMP, 440-460V	EMG90584	Timer- on delay
226EE-OL4I	Overload, B18K-I, 2.5-4 AMP, 208-240V	EMG90675	Reversing contactor- 24 volt
35241	Mounting bracket	EMG92003-1	Subplate electrical
35374	Terminal block	EMG92014	Fuse block
35375	End barrier	EMG92016	Din rail- 11" long
35376	End anchor	EMG92017	Timer socket
BLK323	End barrier	H281EE-31	Overload, B18K-N, 10-16 Amp, 440-460V
EMG90176	Transformer 200/208/230/460- 24V	H281EE-321	Overload, B18K-ON, 21-26 Amp, 208-240V
EMG90177A	Contactator 24V coil w/ aux. contacts	HHS040S	Hex head screw 1/4-20 x 3/4 SS
EMG90180	Aux. contact block-N.C.	HN15S	Hex nut 1/4 -20 SS
EMG90194	Aux. contact block-N.O.	PC141-1	Transformer 208/240-277/380/480V - 24V
EMG90249	Buss, connecting link-LSK series	PC152	Terminal
EMG90552	Fuse 3 AMP- time delay	PC257	Jumper- internal 6mm

ITEMS NOT SHOWN

14672	Multi hole strain relief	BES16980	Terminal, #6 spade, insulated nylon
1773-1	Lock ring, 1/2"	BLK323	End barrier
241-B	Boot, Hubbell	EMG90249	O/L buss bar
2567	Ring terminal, red	EMG92001	Control cord, 8 conductor
418	Wire nut, orange	EMG92002	Terminal, push on 16-14 AWG insulated
419	Wire nut, yellow	EMG92015	Jumper, internal 3-pole
420	Wire nut, red	EMG92016	Din rail, 11 ⁵³ /64 inches long
53511	Cord connector, 14/4 AL	EMG92022	Strain relief connector .375-500R
53583	Bowl Nut Wrench, 3/4", w/ chain	EMG92099	EMG-32 Operating Manual
53687	Decal, "Caution Do Not Fill Above Line"	H653-E	Warning label, English
53689	Cord connector 10/4 AL	H653-F	Warning label, French
53891	Auger drive shaft key	H653-SP	Warning label, Spanish
53894	Auger drive shaft lock washer	H486	Decal, "Rotation"
53895	Auger drive shaft lock nut	H340	Ring wrench
54268	Power cord, 10/4, 13 feet	PC152	Terminal din rail mount
54268-2	Extension cord, 10-4, 2 1/2 feet	PC257	Jumper- internal 6mm
56311	Plug, Hubbell	T3289	Terminal, 1/4" female spade, blue
57103-1	Lock ring, 1"	T3289-8	Terminal, #8 ring, blue
BCC51-1	Terminal, ring ground, non-insulated		

FASTENERS

AN15S	Acorn nut, 1/4-20, SS	HN19S	Hex nut, 5/16-18, SS
FW04S	Flat washer, #10	HN43S	Hex nut, 1/2-13, SS
FW05S	Flat washer, 1/4, SS	HN49S	Hex nut, 5/8-11, SS
FW07S	Flat washer, 3/8 x 7/8 OD, SS	HNNL15S	Hex nylok nut, 1/4-20, SS
FW11S	Flat washer, 1/2, SS	HNNL25S	Hex nylok nut, 3/8-16, SS
H374-1	Pop rivet, 1/8 x 1/4, ali.	LW05S	Lock washer, #10, SS
HHS012S	Hex head screw, 10-32 x 1/2, SS	LWET05S	Lock washer, #10 external tooth
HHS025S	Hex head screw, 1/4-20 x 1/2, SS	LW10S	Lock washer, 1/4, SS
HHS040S	Hex head screw, 1/4-20 x 3/4, SS	LW15S	Lock washer, 5/16, SS
HHS060S	Hex head screw, 5/16-18 x 1, SS	LW20S	Lock washer, 3/8, SS
HHS067S	Hex head screw, 3/8-16 x 3/4, SS	LW35S	Lock washer, 5/8, SS
HHS075S	Hex head screw, 3/8-16 x 1 1/4, SS	PHS033S	Pan head screw, 10-32 x 3/8, SS
HHS083S	Hex head screw, 3/8-16 x 1 3/4, SS	RHS020S	Round head screw, 6-32 x 3/8, SS
HHS126S	Hex head screw, 1/2-13 x 1 1/4, SS	RHS069S	Round head screw, 10-32 x 3/8, SS
HHS129S	Hex head screw, 1/2-13 x 2, SS	RHS072S	Round head screw, 8-32 x 3/8, SS
HHS147S	Hex head screw, 5/8-11 x 2, SS	RHS090S	Round head screw, 10-32 x 1/4, SS
HHS152S	Hex head screw, 5/8-18 x 1 1/4, SS	RHS10S	Round head screw, 10-32 x 3/4, SS
HN07S	Hex nut, 10-24, SS	RHS31S	Round head screw, 1/4-20 x 1, SS
HN10S	Hex nut, 10-32, SS	WN20S	Wing nut, 3/8-16, SS
HN15S	Hex nut, 1/4-20, SS		

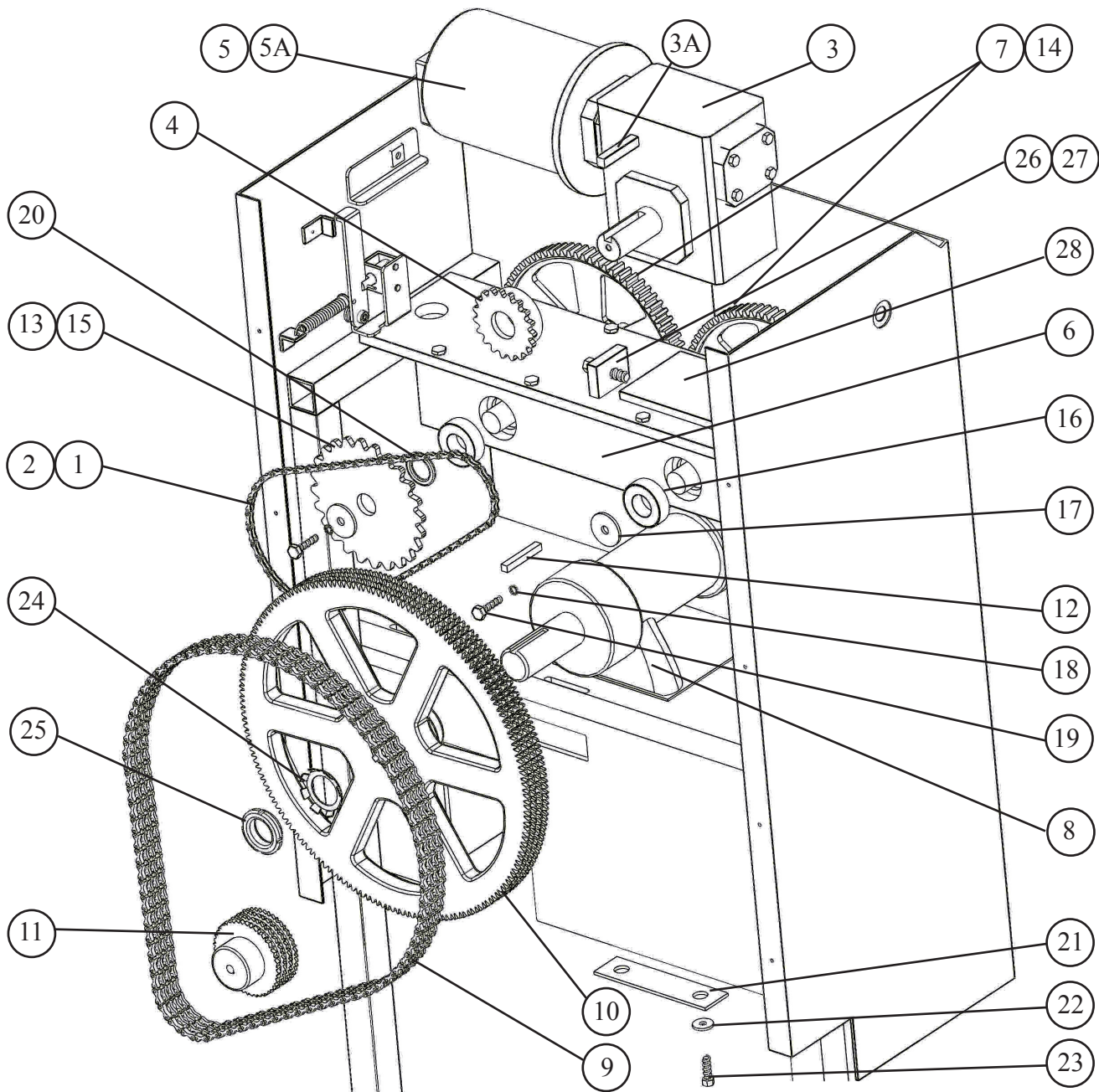

Fig.	Item No.	Description
	1	EMG20050-06 #40 roller chain
	2	EMG20050-01 #40 chain connecting link
	3	EMG20301G Grove gear reducer assembly
	3A	EMG62197 1/4 x 2 1/4" reducer shaft key
	4	EMG62012 40B20F 1 1/4" sprocket
	5	EMG62013 Leeson 3/4 HP RS56-C drip proof
	5A	EMG62196 3/16 X 1 1/4 motor shaft key- 3/4 HP
	6	EMG62015 Paddle shaft bearing mount
	7	EMG62092 Spur gear
	8	53886 Bearing box assembly
	9	H384-CL Roller chain, 35-4 w/ connecting link
	10	53727 Drive sprocket, 141 tooth
	11	H382-1 Motor pinion, 22 tooth
	12	53891 Auger drive shaft key
	13	EMG62135 1/4 Sq x 1" Driven Sprocket key

Fig.	Item No.	Description
	14	EMG62136 1/4 Sq x 1 7/16" Spur gear key
	15	EMG82029 40B36F 1" sprocket
	16	EMG82032 Sealed bearing
	17	EMG92032 Flat washer, .397 x 1 1/4 x .120 thk. SS
	18	LW20S Lock washer, 3/8" SS
	19	HHS070S Hex head screw, 3/8-16 x 1, SS
	20	EMG82034 Inner Race Spacer
	21	EMG92021-1 Washer, Journal Box- 2 holes
	22	LW35S Lock washer, 3/8" SS
	23	HHS153S Hex head screw, 3/8-18 x 1 1/2, SS
	24	53894 Auger Drive Shaft Lock Washer
	25	53895 Auger Drive Shaft Lock Nut
	26	HHS093S Hex head screw, 3/8-16 x 2 3/4", SS
	27	HN30S Hex jam nut, 3/8-16, SS
	28	EMG62020G Adpt. Plate Grove Gear Reducer

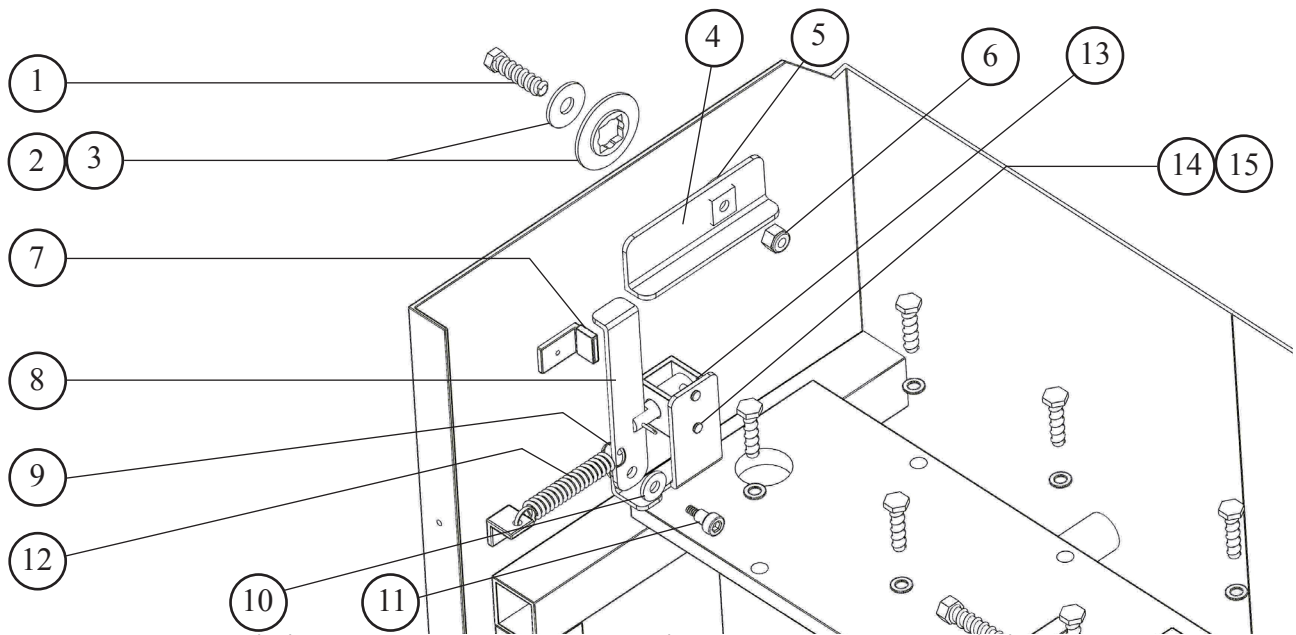
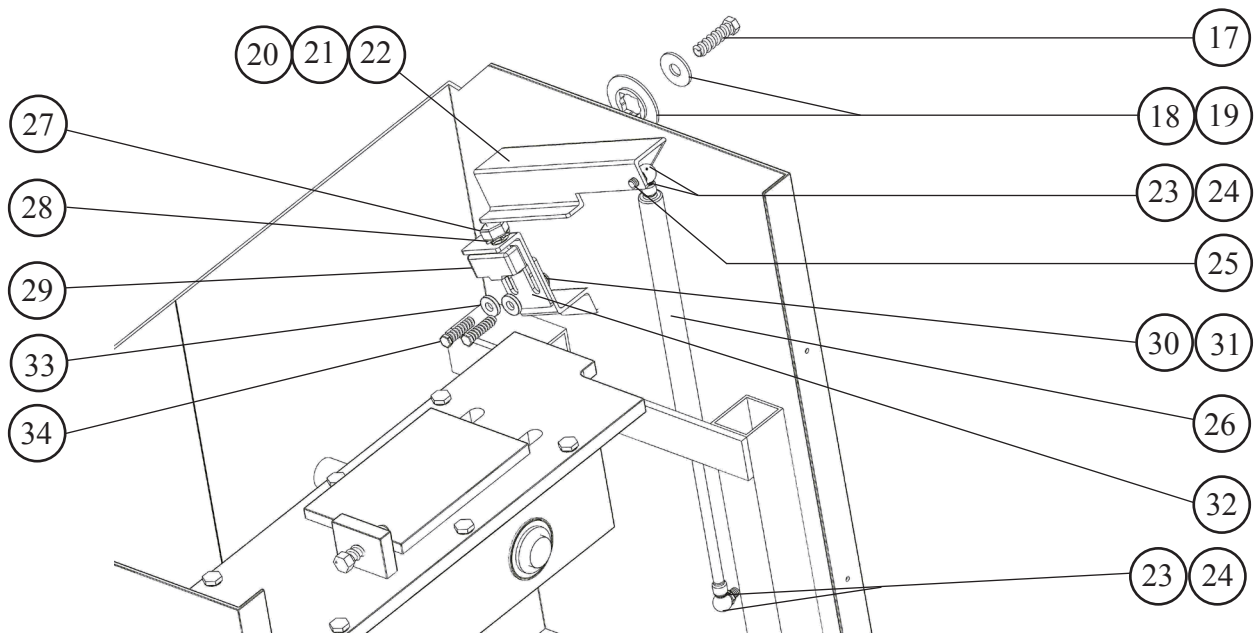

Fig.	Item No.	Description	Fig.	Item No.	Description
	1	HHS086S Hex head screw $\frac{3}{8}$ -16 x 2, SS	9	HN19S Hex Nut, $\frac{5}{16}$ -18, SS	
	2	EMG92032 Flat washer, .397 x $1\frac{1}{4}$ x .120 thk. SS	10	EMG62204 Spacer, Lid lock arm shoulder bolt	
	3	EMG62182 Sleeve Bushing	11	SSB40S Shoulder bolt, $\frac{3}{8}$ Dia. $\frac{5}{16}$ -18 x $\frac{3}{8}$ "	
	4	EMG62179 Safety lid lock weldment arm	12	EMG62044 Spring lid lock	
	5	EMG62181 Nylon washer, lid hinge	13	EMG62143 24 Volt solenoid	
	6	HNNL25S Nylon Insert, Hex nut $\frac{3}{8}$ -16	14	PHS033S Panhead screw, 13-32 x $\frac{3}{8}$ "	
	7	EMG62205 Cushion	15	LWET05S Lock washer, ext. tooth #10	
	8	EMG62140-1 Lid lock lever, $5\frac{1}{4}$ "			



17	HHS086S Hex head screw $\frac{3}{8}$ -16 x 2, SS	26	EMG62190 Gas Spring, Internal
18	EMG92032 Flat washer, .397 x $1\frac{1}{4}$ x .120 thk. SS	27	HNM45 Hex Nut, M12 x 1
19	EMG62182 Sleeve Bushing	28	LWET30S $\frac{1}{2}$ " External tooth washer
20	EMG62181 Nylon washer, lid hinge	29	EMG90015 Micro switch
21	EMG62183 Lid cylinder arm weldment	30	FW06S Flat washer, $\frac{1}{4}$ ", SS
22	HNNL25S Nylon Insert, Hex nut $\frac{3}{8}$ -16	31	HNNL15S Hex nut Nylon Insert, $\frac{1}{4}$ -20
23	EMG62062-1 Ball stud, Gas spring, $\frac{5}{16}$ -10	32	EMG62081 Bracket, Micro Switch
24	EMG62190-1 Retaning clip, Gas spring	33	FW06S Flat washer, $\frac{1}{4}$ ", SS
25	HN19S Hex nut, $\frac{5}{16}$ -18, SS	34	HHS040S Hex head screw, $\frac{1}{4}$ -20 x $\frac{3}{4}$ ", SS

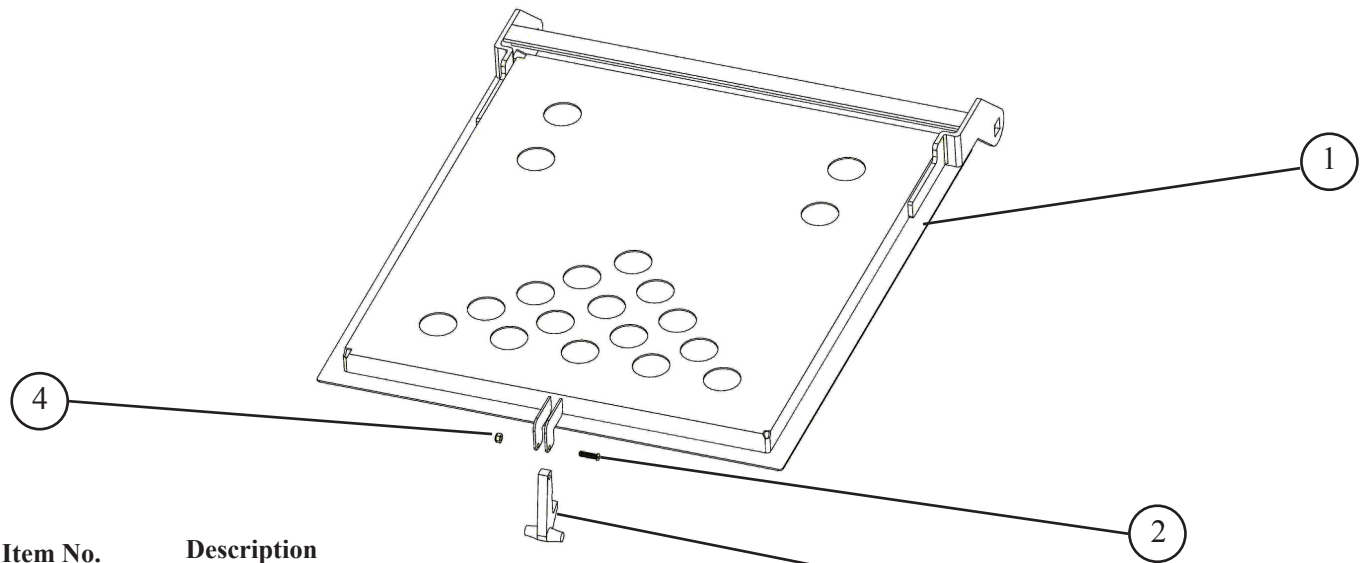
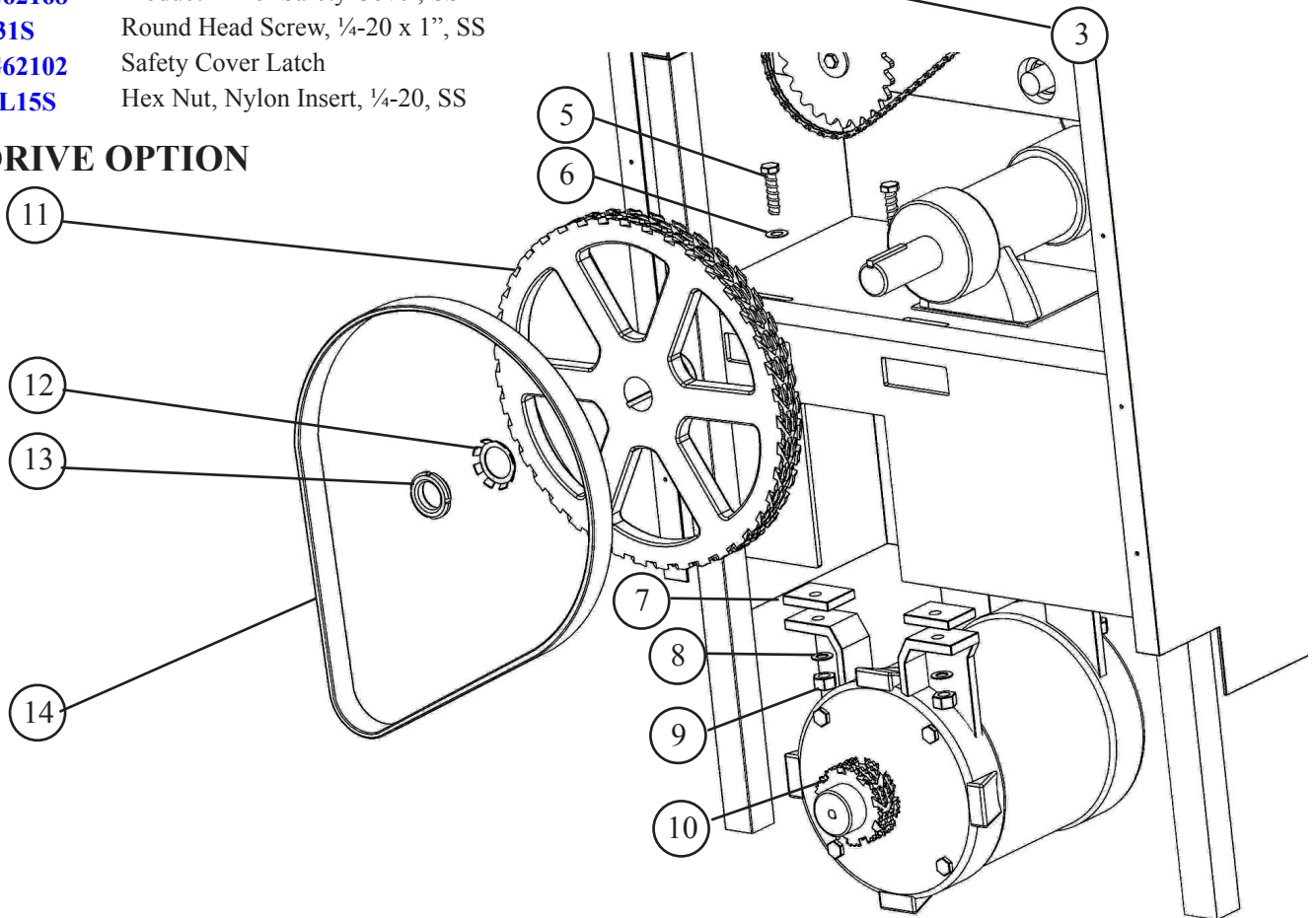

Fig.	Item No.	Description
1	EMG62168	Product Mixer Safety Cover, SS
2	RHS31S	Round Head Screw, 1/4-20 x 1", SS
3	EMG62102	Safety Cover Latch
4	HNNL15S	Hex Nut, Nylon Insert, 1/4-20, SS

BELT DRIVE OPTION



5	HHS129S	Hex Head Screw 1/2-13 x 2", SS	11	H383-EAGL	Main Driven Sprocket, Eagle 140 Tooth up to S/N: 7682
5	*HHS135S	Hex Head Screw 1/2-13 x 2 1/2", SS	11	*53727-EAGL	Main Driven Sprocket, Eagle 166 Tooth starting with S/N: 7683
6	*FW15S	Flat Washer 1/2", SS	12	53894	Auger Drive Shaft Lock Washer
7	*57018	Motor Spacer (4 required)	13	53895	Auger Drive Shaft Lock Nut
8	*LW30S	Lock Washer 1/2", SS	14	H384-EAGL	Drive Belt, Eagle #W-1280 up to S/N: 7682
9	*HN42S	Hex Nut 1/2-13, SS	14	*H384-EAGL-1440	Drive Belt, Eagle #W-1440 starting with S/N: 7683
10	H382-EAGL	Motor Pinion Sprocket Eagle 22 Tooth up to S/N: 7682			
10	*H382-EAGL-26	Motor Pinion Sprocket Eagle 26 Tooth starting with S/N: 7683			

*Items required if field converting from Chain Drive to Eagle Belt Drive

Fig.	Item No.	Description
7	EMG62050	Hopper weldment
8	EMG62092	Spur gear
9	SSS26	Set screw, $\frac{5}{16}$ -18 x $\frac{1}{2}$ "
10	EMG82034	Spacer, inner bearing race
11	EMG82032	Sealed bearing
12	EMG62015	Paddle shaft bearing mount
13	EMG92032	Flat washer, .397 x $1\frac{1}{4}$ x .120 thk. SS
14	HHS070S	Hex screw $\frac{3}{8}$ -16 x 1", SS
15	EMG62012	40B20F x $1\frac{1}{4}$ " Sprocket
16	EMG20050-06	#40 Roller chain w/ master link
17	EMG20050-01	#40 Chain connecting link
18	EMG82029	40B36F x 1" bore sprocket
19	SSS26	Set screw, $\frac{5}{16}$ -18 x $\frac{1}{2}$ "

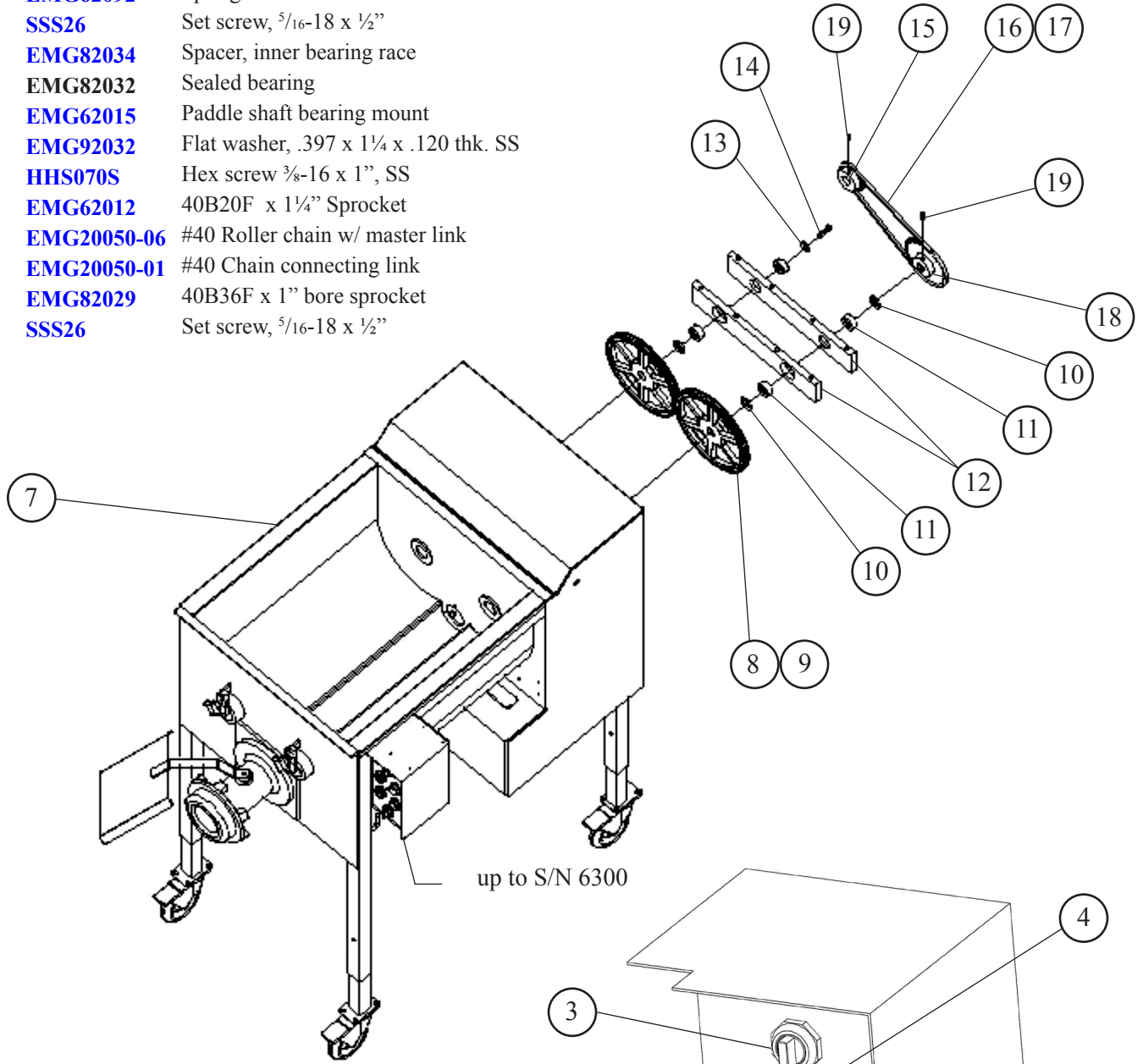
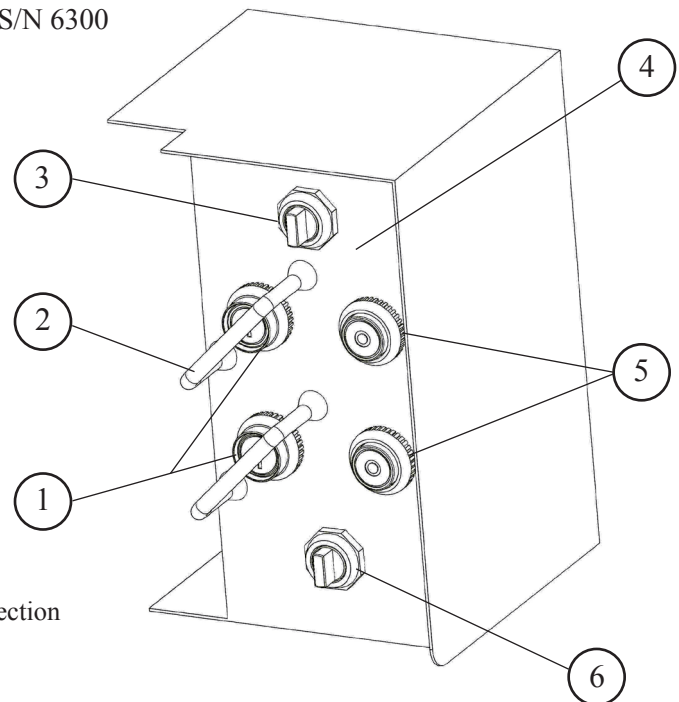
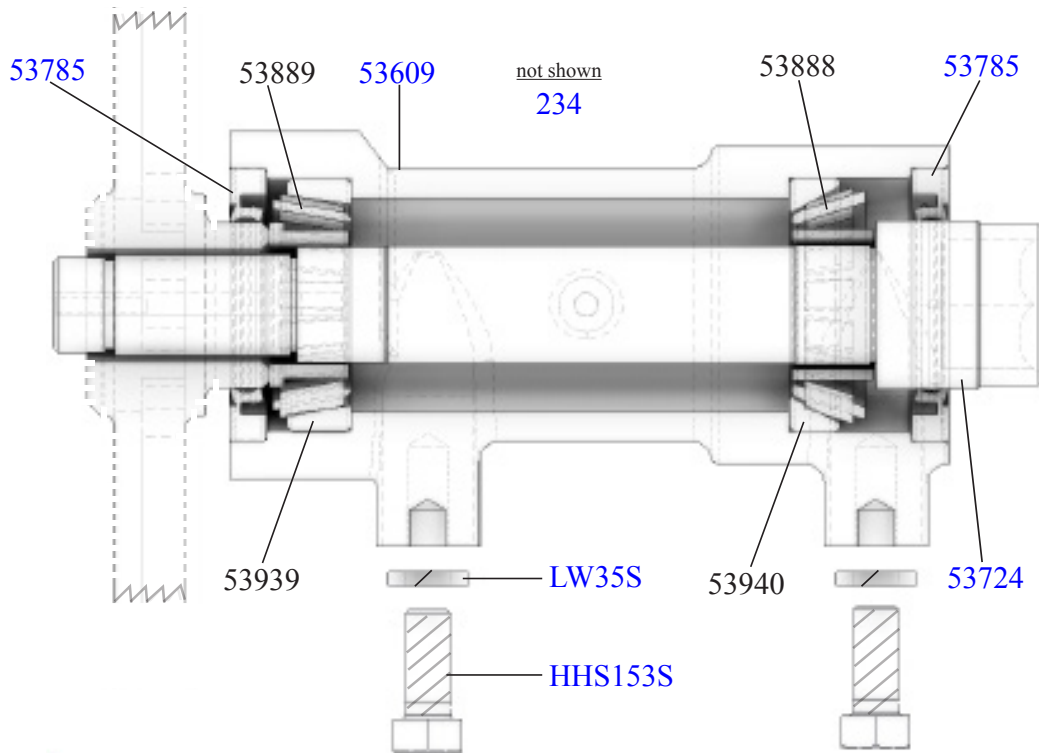

Fig.	Item No.	Description
1	42MC-Y73	Start pushbutton, Green
2	50655-2	Switch guard, SS
3	EMG90676	3 Position, Selector Switch, Paddle direction
4	EMG62115	Label, Control panel
5	42MC-Y74	Stop pushbutton, Red
6	EMG90668	Selector switch, Hand/Foot control



ITEM No. **53886** JOURNAL BOX ASSEMBLY



Item No.	Description	Item No.	Description
53886	Journal box assembly	53889, 53939	Rear bearing cup/cone assembly Use H311A
53609	Journal box housing	234	Grease fitting 1/8 NPT
53724	Auger drive shaft	LW35S	Lock washer 5/8, SS (4 ea.)
53785	Journal box seal (2 ea.)	HHS153S	Hex head screw 5/8-18 x 1 1/2, SS (4 ea.)
53888, 53940	Front bearing cup/cone assembly Use H310A		

RIGHT HAND HINGE ASSEMBLY SHOWN IN CLOSED POSITION

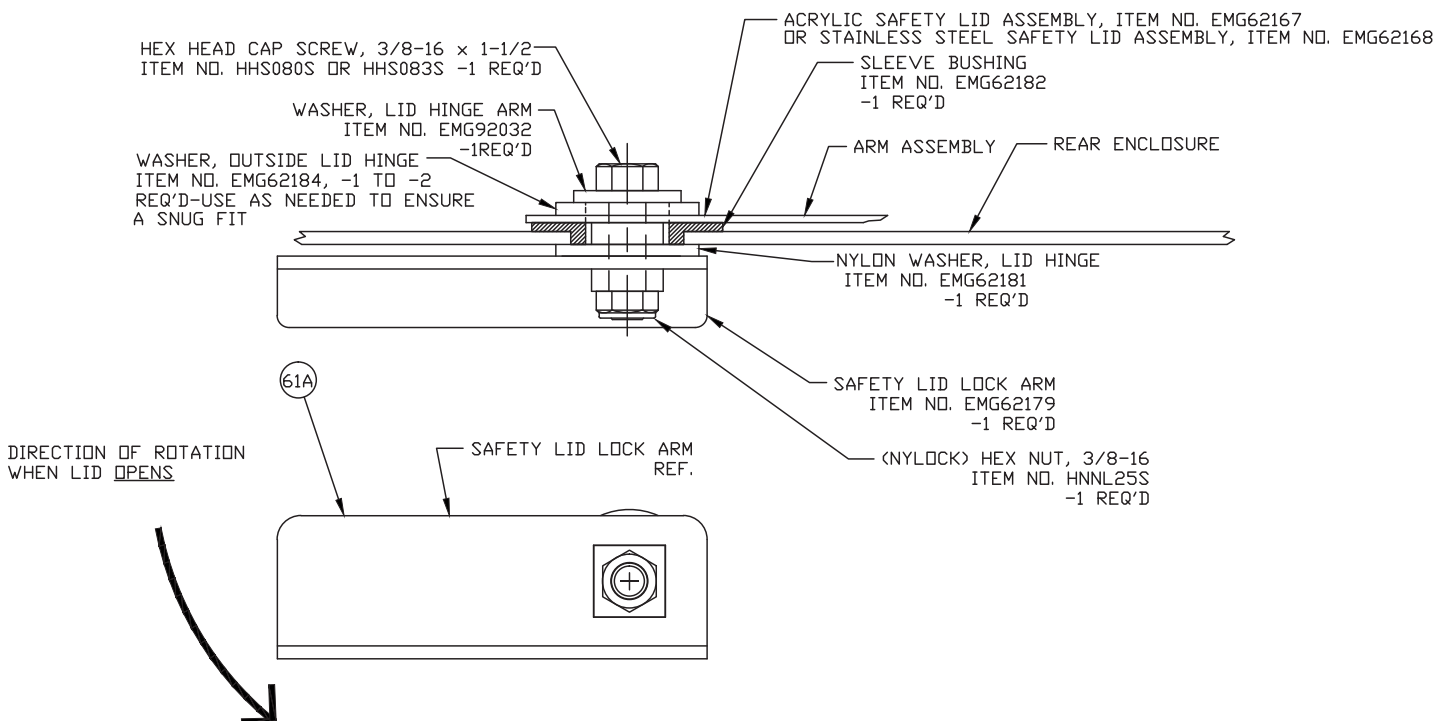

STANDARD EQUIPMENT

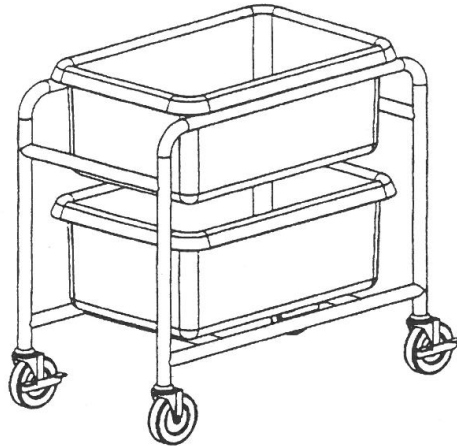

EMG20699-1

**Multiple Lug Dolly w/ 5" Casters/Brakes
(Lugs not supplied)**

SAFETY LABEL LOCATIONS



KEEP HANDS OUT OF HOPPER

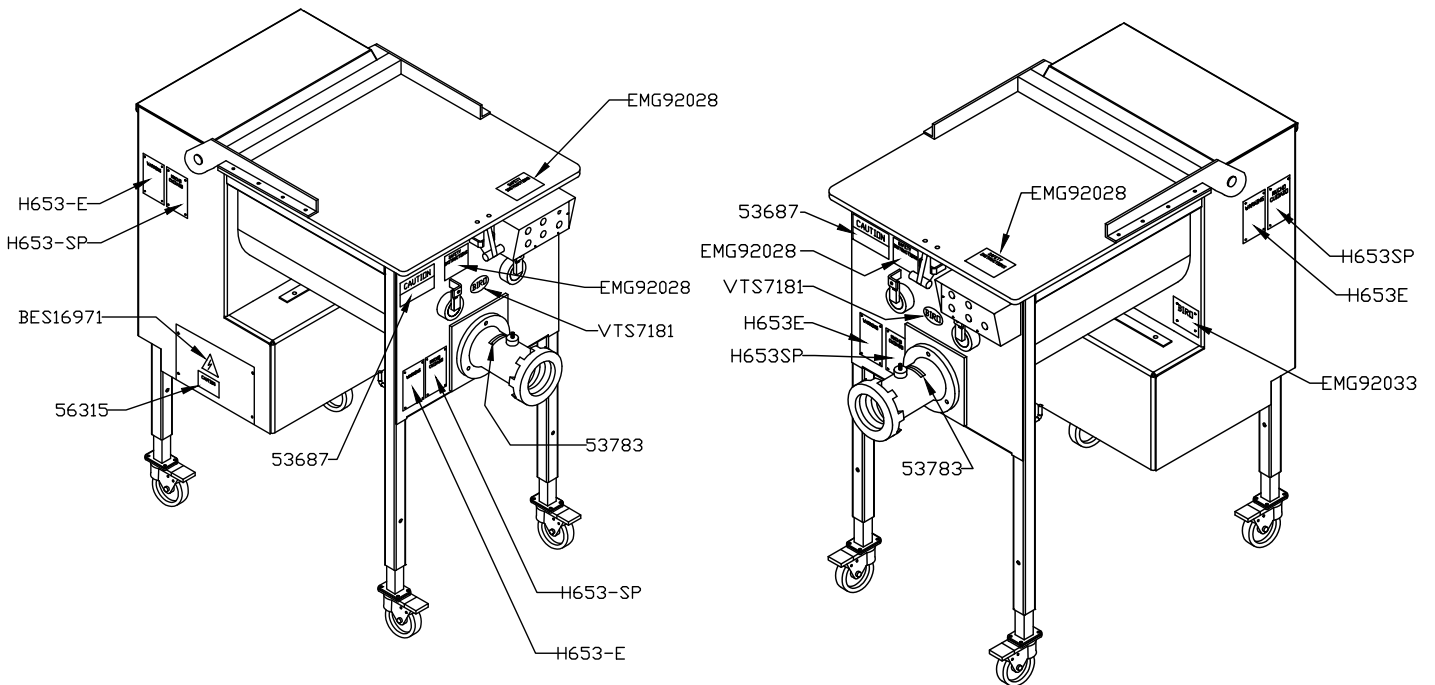

SAFETY LABELS



#VTS7181

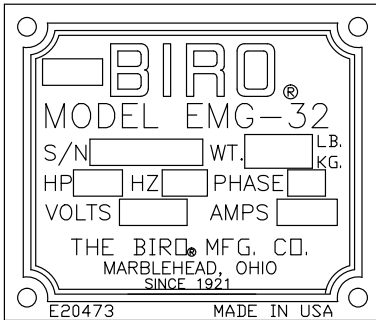

#EMG92033



#H653-E



#H653-SP

-NOT TO SCALE-



#53687



#EMG62198

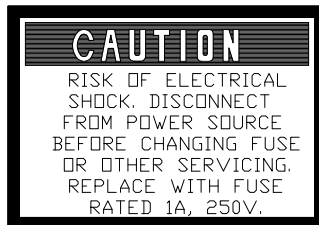

#56315

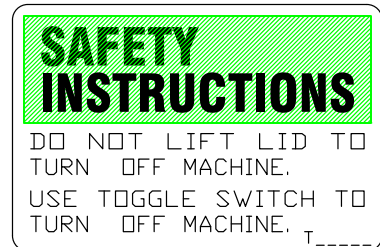

#EMG92028



#53783

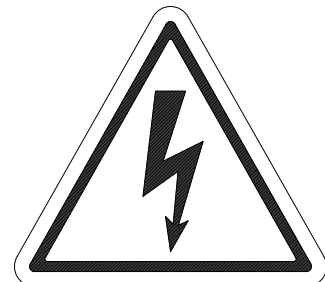

#BES16971

**TANDEM OPERATION
ILLUSTRATION**

MODEL	HHP
342548,7548,552,7552	
A	15-5/8" (396.8mm)
B	32-1/4" (819.2mm)
C	50" (1270mm)
D	47-3/8" (1203.3mm)

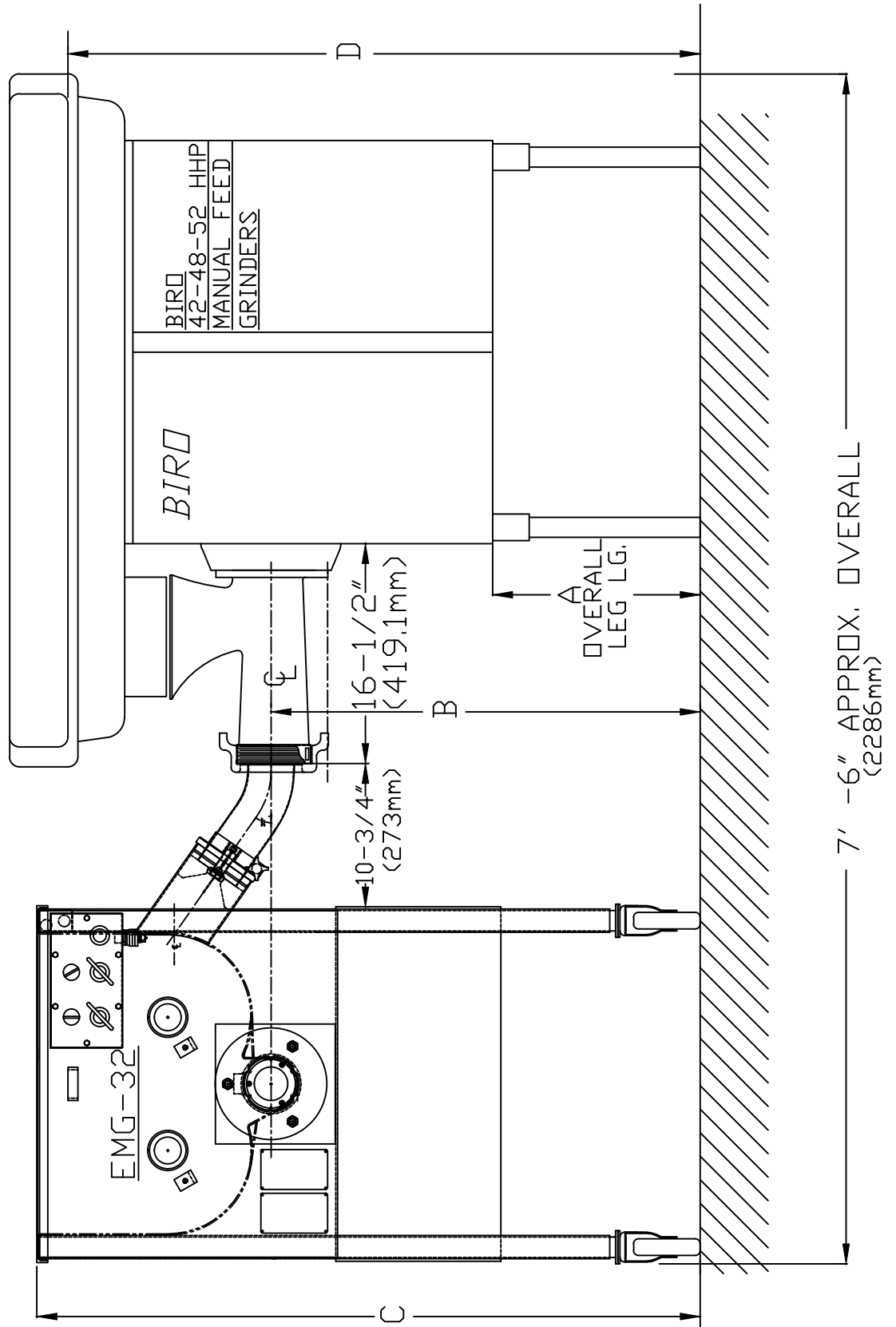

LIMITED WARRANTY:

WARRANTY: The BIRO Manufacturing Company warrants that the BIRO EMG-32 Mixer Grinder/Chopper will be free from defects in material and workmanship under normal use and with recommended service. BIRO will replace defective parts, which are covered by this limited warranty, provided that the defective parts are authorized for return, shipping charges prepaid, to a designated factory for inspection and/or testing.

DURATION OF WARRANTY: The warranty period for all parts covered by this limited warranty is one (1) year from date of Inspection/Demonstration advised on the returned Warranty Registration Card, or eighteen (18) months from original factory ship date, whichever occurs first, except as noted below.

PARTS NOT COVERED BY WARRANTY: The following are **not** covered by this limited warranty: wearable parts in the grinding system such as bowl, ring, worm, drive shaft, and knife drive pin. This limited warranty does not apply to machines sold as used, rebuilt, modified, or altered from the original construction in which the machine was shipped from the factory. Water contaminated electrical systems are not covered under this limited warranty. BIRO is not responsible for electrical connection of equipment, adjustments to the switch controls or any other electrical requirements, which must be performed only by a certified electrician. BIRO is not responsible for service charges or labor required to replace any part covered by this limited warranty or for any damages resulting from misuse, abuse, lack of proper or recommended service.

EXCLUSION OF WARRANTIES AND LIMITATION OF REMEDIES: BIRO gives no warranties other than those expressly stated in this limited warranty. THE IMPLIED WARRANTY OF MERCHANTABILITY, THE IMPLIED WARRANTY OF FITNESS FOR PROCESSING FOOD PRODUCTS, AND ALL OTHER IMPLIED WARRANTIES ARE SPECIFICALLY EXCLUDED. BIRO IS NOT LIABLE FOR CONSEQUENTIAL OR INCIDENTAL DAMAGES, EXPENSES, OR LOSSES. THE REMEDIES PROVIDED IN THIS BIRO LIMITED WARRANTY ARE PURCHASER'S SOLE AND EXCLUSIVE REMEDIES AGAINST BIRO.

REGISTRATION CARDS: You must sign, date and complete the warranty registration card supplied with each machine. The warranty card must be returned to The BIRO Manufacturing Company for proper registration. If no warranty card is returned to BIRO, the warranty period will begin from the date the machine was originally shipped from the factory.

HOW TO GET SERVICE:

1. Contact the agency from whom you purchased the machine; or
2. Consult the yellow pages of the phone directory for the nearest authorized dealer; or
3. Contact Biro Manufacturing Company for the nearest authorized service entity in your area.

BIRO MANUFACTURING COMPANY

1114 W. Main St.

Marblehead, OH 43440

Ph. 419-798-4451

Fax 419-798-9106

E-mail: Service@birosaw.com

Web: www.birosaw.com