

Slicer
VSI330 F / VSI330 F W
VSI330 F T / VSI330 F TW

Instruction manual NSF

38065447007 en-US

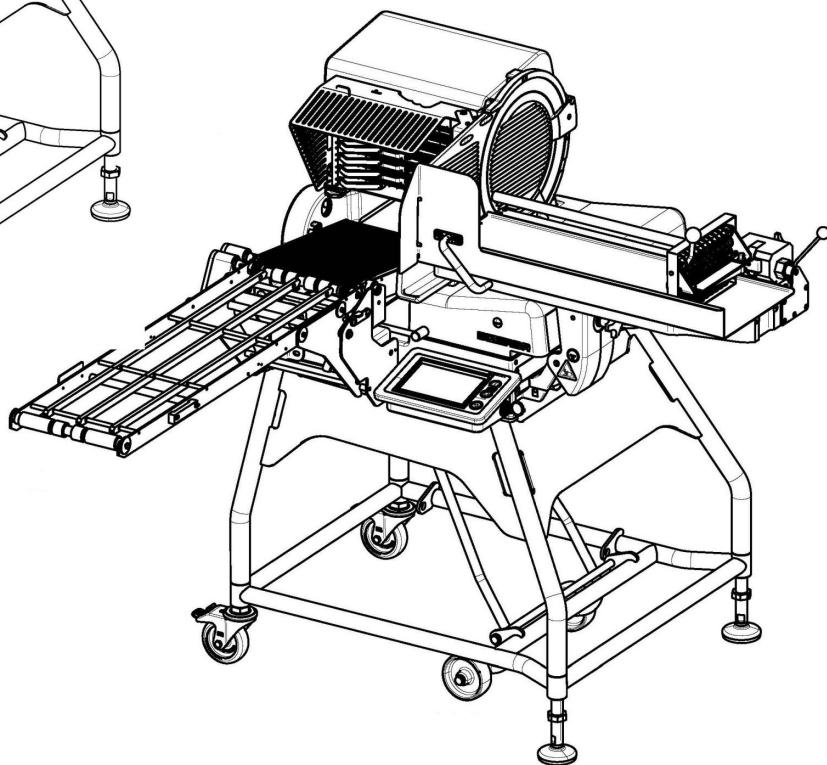
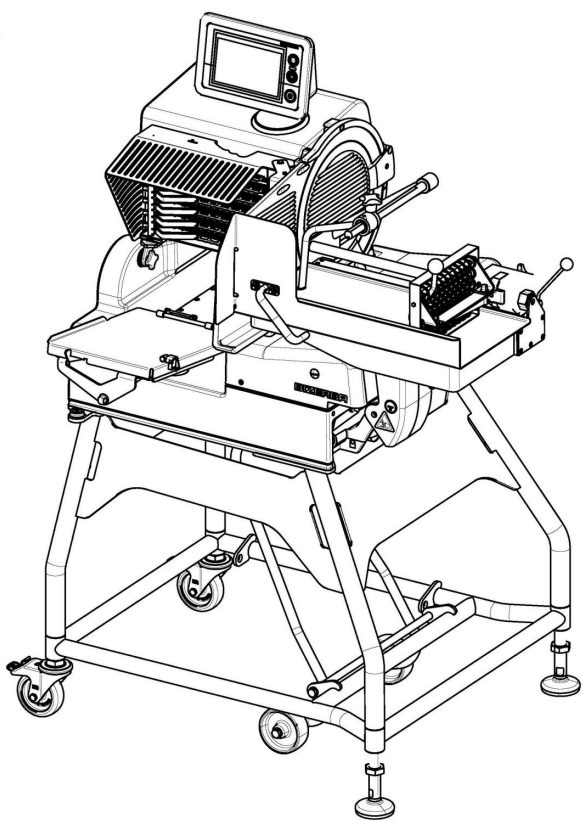

Bizerba Service
www.bizerba.com

© 01 / 2020

Alle Rechte vorbehalten
All rights reserved
Tous droits réservés
Reservados todos los derechos
Tutti i diritti riservati

Bizerba SE & Co. KG,
72336 Balingen

Postfach 10 01 64
72301 Balingen, Germany
Telephone (+49 7433) 12-0, Fax (+49 7433) 12-2696
E-mail: marketing@bizerba.com
Internet: www.bizerba.com

Table of Contents

1	About these instructions	6
1.1	Safe-keeping	6
1.2	Target group	6
1.3	Symbols used	6
1.4	Warnings	7
2	About this machine	8
2.1	Intended use	8
2.2	Machine description	9
2.2.1	Names of components VSI W	10
2.2.2	Names of components VSI T	12
2.2.3	Names of components VSI TW	14
2.2.4	Accessories	15
2.3	Warranty	16
2.4	Data security	16
2.5	Disposal of the machine / environmental protection	16
3	Safety instructions	17
3.1	General notes on safety	17
3.2	Safety instructions for transport and installation	18
3.3	Safety instructions during operation, slicing	19
3.4	Safety instructions for sharpening, cleaning	20
3.5	Protective and safety devices	20
3.6	System design related residual hazards	21
4	Installation	23
4.1	Unpacking instructions	23
4.2	Transport and storage	24
4.3	Installation and assembly	24
4.3.1	Installation requirements	24
4.3.2	Position on stand	25
4.3.3	Electrical connection	27
4.4	Start-up	28
4.4.1	Switching the slicer on	28
4.4.2	Switching the machine off	29
4.5	Decommissioning	29
5	Machine and operating elements	30
5.1	Display and operating unit	30
5.2	Icons on the touchscreen	30
5.2.1	Parameter symbols	33
5.2.2	Anchor symbol	38
5.2.3	Depositing patterns	39
5.3	Paper holder	44

5.4	Product fixation device	45
6	Operation.....	46
6.1	Log in operator	46
6.2	Main page (individually configured operator page).....	47
6.3	Navigation between the pages	48
6.4	Parameter page.....	48
6.5	Tile manager.....	49
6.6	Image manager	49
6.7	Search mask.....	50
6.8	Settings.....	51
6.8.1	User management.....	52
6.8.2	Software settings	54
6.8.3	PLU data backup	54
6.8.4	Licensing of additional functions.....	55
6.8.5	BRAIN2 function	56
6.8.6	Cloud function.....	58
6.8.7	I/O interface	58
6.8.8	Further settings.....	61
6.9	Load the product.....	62
6.10	First cut function	64
6.11	Discharge function.....	65
6.12	Slice product.....	66
6.12.1	PLU direct key	70
6.13	Slicing to target weight	70
6.13.1	Reference weight.....	72
6.13.2	Conditions for weighing	72
6.14	Ending slicing	73
7	Troubleshooting	75
7.1	Procedure	75
7.2	Fault description	75
8	Maintenance.....	76
8.1	Preparation for cleaning	76
8.2	Removing components.....	77
8.3	Cleaning	85
8.4	Cleaning plan for slicers	90
8.5	Preparing the machine for operation	92
8.6	Service and maintenance	100
8.6.1	Blade sharpening.....	100
8.6.2	Sharpening	102
8.6.3	Honing	103
8.6.4	Checking seals and sealings	104

9	Technical data	106
9.1	Dimensions VSI / VSI W.....	106
9.2	Dimensions VSI T.....	107
9.3	Dimensions VSI TW.....	108
9.4	Technical data.....	110
9.5	Power supply.....	111
9.6	Ambient conditions.....	111
10	Attachment	112
10.1	Parameter defaults and input ranges.....	112
10.2	Set programs.....	115
10.3	Checklist installation and start-up.....	117

1 About these instructions

Read the instruction manual very carefully before connecting and switching on the machine to ensure that you utilize the full quality and potential of this machine and avoid any potential risks.

This instruction manual covers the use, installation, operating, cleaning and maintenance of the machine.

Our products undergo continuous further development and are subject to different country-specific regulations. Examples of pictures and graphics included in these instructions may vary from the version you have received.

1.1 Safe-keeping

The owner's manual are an integral part of the machine and must be stored close to the machine to be easily accessible to others.

If the machine is sold, the owner's manual must be included in its entirety.

1.2 Target group



The machine may only be operated by trained personnel. This means that the operator has to be familiar with the contents of the instruction manual.

The minimum age of the operating personnel by German law is 14. Other age limits may apply according to the corresponding national regulations. Therefore the operating company must check the legislation at the place of machine installation.

Installation, maintenance and repair works must be performed by Bizerba authorized specialists only.

1.3 Symbols used

Various symbols are used in these instructions.

Icon	Description
	Text with arrow prompts you to carry out an action.
	Item number in figure.
<Key>	Text within <> refers to a key.
"Display"	Text within "" shows the display text.

Requirements are displayed with a gray background.

Instruction



These instructions are mandatory for you.



Information



This information is intended for better understanding.

1.4 Warnings

Warnings are divided into danger levels by the signal word above the warning symbol. Structure of warnings and meaning of signal words are described in these instructions as follows.

	<p>⚠ DANGER</p> <p>Source of danger with high risk of imminent danger to persons! The consequences are: life threatening injuries, serious health damage</p> <ul style="list-style-type: none">– Measurements for prevention of danger are specified.
	<p>⚠ WARNING</p> <p>Source of danger with medium risk of possible danger to persons! The consequences can be: serious injuries, damage to health, serious damage to property</p> <ul style="list-style-type: none">– Measurements for prevention of danger are specified.
	<p>⚠ CAUTION</p> <p>Source of danger with low risk of possible danger to persons! The consequences can be: injuries, damage to property.</p> <ul style="list-style-type: none">– Measurements for prevention of danger are specified.
	<p>NOTICE</p> <p>Source of danger, improper use! Damage to property can result.</p> <ul style="list-style-type: none">– Measurements for prevention of danger are specified.

2 About this machine

2.1 Intended use

Bizerba slicers are intended for use at work only.

They may only be operated by instructed personnel over the age of 14. [► 6]

The fully automatic vertical slicers VSI slice the fed product and deposit the slices based on the program setting.

Permitted product

Approved sliced products, taking sizes into consideration

- All kinds of cold cuts, deli meat
- Ham, bacon
- Smoked ham with / without rind
- Roast meats, roast beef
- Meat, roulades
- Sliceable cheese
- Fruit, vegetables
- Bread

Note: If cheese is the main product being sliced, we recommend using a special cheese blade.

Slicing of other materials requires prior written approval by Bizerba product management.

Non-permitted product

The following may not be sliced due to risk of injury and damage:

- NON-FOOD articles
- Bone-in products
- Frozen products
- Substances representing a health risk, in particular toxic, corrosive, highly and extremely inflammable and explosive substances

Product sizes

min. angular 50 x 50 mm = 2" x 2" or round 50 mm = 2" diameter

max. angular 240 x 180 mm = 9.5" x 7.1" or round 180 mm = 7.1" diameter

Several sliced product pieces can be placed next to each other. Loading width max. 240 mm = 9.5".

Applications

The slicing machines are intended for installation in the sales area. The use in the preparation area is permitted taking into account cleaning procedures and protection class.

Permissible ambient temperatures from -10°C to 40°C (+14 to +104 degF).

Operating time

The slicers are designed for permanent operation.

2.2 Machine description

The fully automatic (F) vertical slicer (VS) for the industrial area (I) comes with a 330 mm blade.

Type designations or versions

VSI330 F = machine with depositing table, 400 mm or 600 mm carriage

VSI330 F W = machine with depositing table, scale (W), 400 mm or 600 mm carriage

VSI330 F T = machine with conveyor belt (T), 400 mm or 600 mm carriage

VSI330 F TW = machine with conveyor belt (T), scale (W), 400 mm or 600 mm carriage

All versions are available with a mobile stand.

Drive

Blade drive and carriage drive are operated with mains voltage, the drive for the depositing table, conveyors, depositing arm and chains are operated with low voltage.

The contactor control with self-locking circuit prevents automatic restarting after a power cut. ON/OFF switch and function keys are located on the display and operating unit.

Deposit system

The slicers are equipped with an automatic slice depositing system. The depositing system deposits slices with a max. slice thickness of 12 mm.

The depositing system consists of a chain frame with transport chains, feed roller with guide cam and depositing arm.

The depositing system is controlled based on carriage speed and carriage stroke.

Product holder

The product holder with remnant holder is equipped with a movable gripper hook.

The remnant holder for the 400 mm carriage has its own clamping device which can be swiveled up and stopped in place in order to insert the product. This is not possible for the 600 mm carriage.

Carriage

The machines are fitted with a 400 mm or 600 mm carriage.

With the cleaning program activated and a slice thickness setting below "0" the tilting lock of the carriage is released. This allows the carriage to be tilted to the outside in any position.

Scale

The slicers VSI W / VSI TW are fitted with a scale which is not metrologically approved. Portions are sliced according to a pre-selected weight.

Materials

Machine housing, gauge plate and blade cover are made of anodized aluminum.

The carriage plate is made of stainless steel plate.

All components getting in direct contact with food and materials used in the working area comply with the food hygiene regulations. Bearings in visual range are lubricated with food-grade lubricants.

Vibration

The total vibration of the items, which get into contact with hand and arm is below 2.5 m/s^2 and therefore below the required limited value.

2.2.1 Names of components VSI W

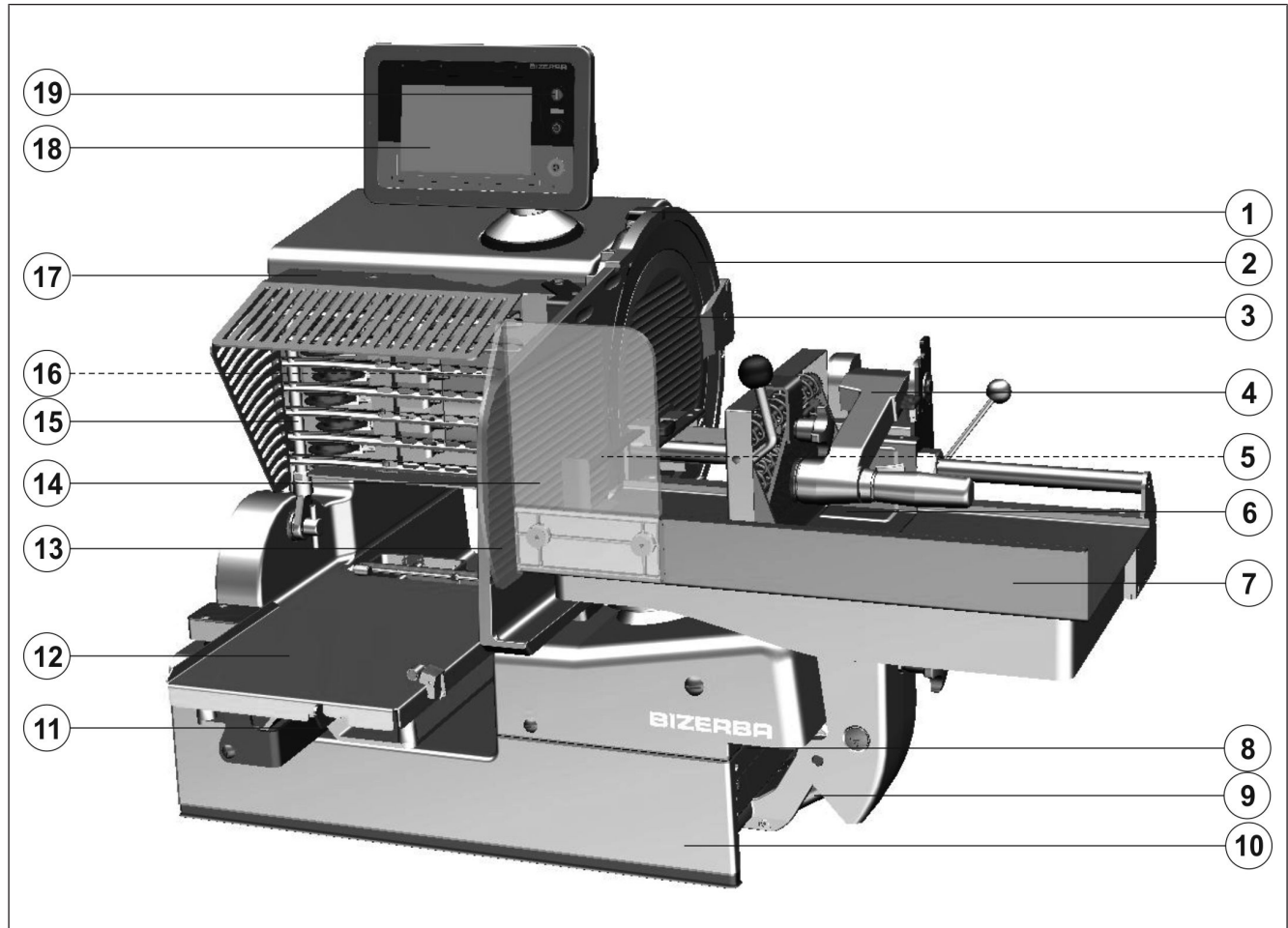

Fig. 1: Names of components VSI W

The machine is available in different versions. The figure shows an example:

- ① Blade guard ring
- ② Blade
- ③ Blade cover
- ④ Product holder complete with remnant holder
- ⑤ Product fixation device, horizontal
- ⑥ Feeding carriage
- ⑦ Carriage
- ⑧ Identification plate
- ⑨ Carriage guide
- ⑩ Machine housing
- ⑪ Scale
- ⑫ Depositing table
- ⑬ Gauge plate
- ⑭ Rear wall
- ⑮ Depositing arm
- ⑯ Feed roller with cam
- ⑰ Chain frame
- ⑱ Display and operating unit on top of machine housing (optionally at the bottom)
- ⑲ ON/OFF switch

2.2.2 Names of components VSI T

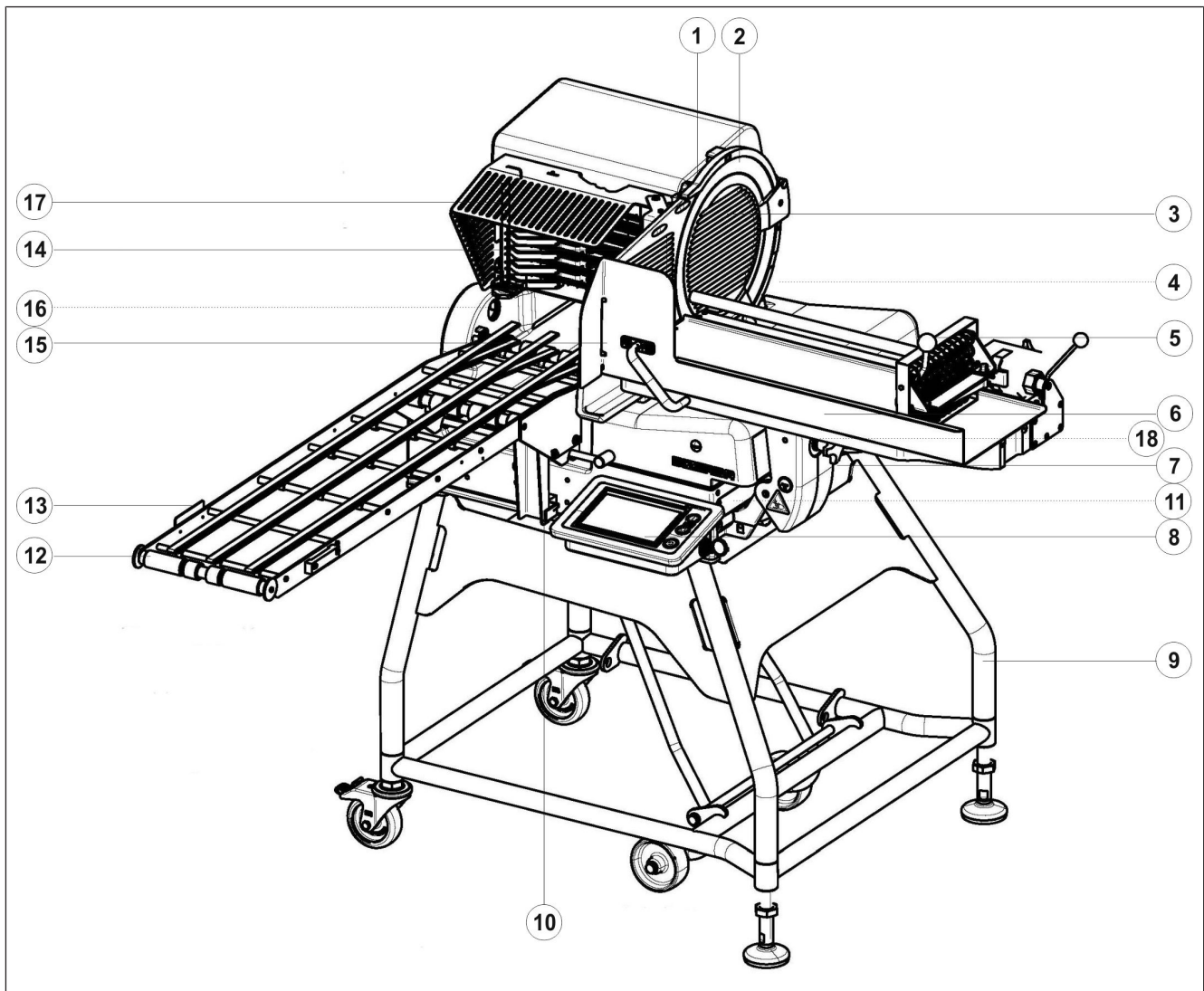

Fig. 2: Names of components VSI T

The machine is available in different versions. The figure shows an example:

- ① Blade guard ring
- ② Blade
- ③ Blade cover
- ④ Product fixation device, vertical
- ⑤ Product holder complete with remnant holder
- ⑥ Carriage
- ⑦ Carriage guide
- ⑧ Display and operating unit with ON/OFF switch at the bottom of the machine housing (optionally on top)
- ⑨ Stand, mobile
- ⑩ Lock at belt support
- ⑪ Identification plate
- ⑫ Conveyor
- ⑬ Light sensor
- ⑭ Gauge plate
- ⑮ Rear wall
- ⑯ Depositing arm
- ⑰ Chain frame with feed roller
- ⑱ Star knob screw on carriage foot

2.2.3 Names of components VSI TW

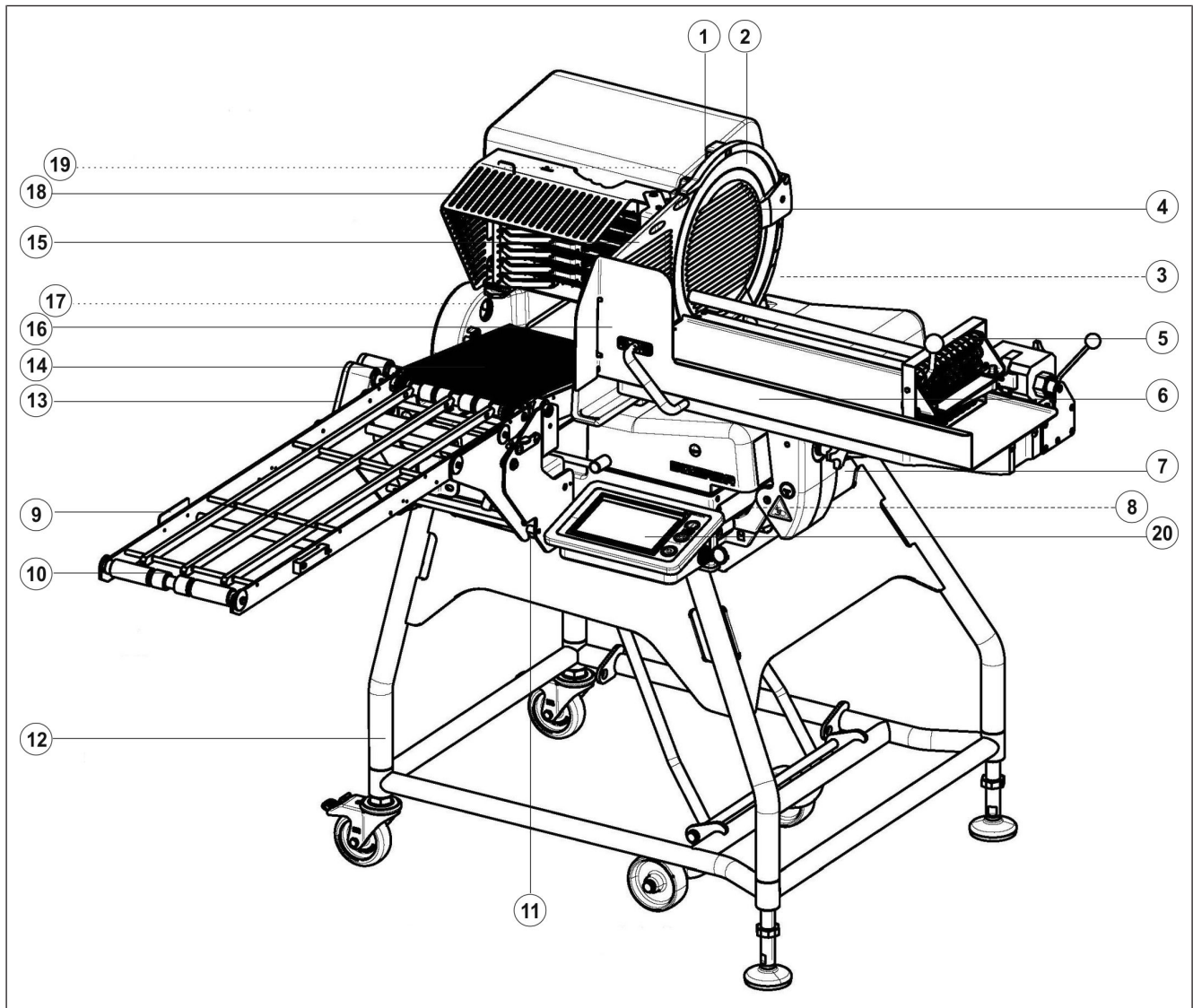
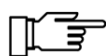

Fig. 3: Names of components VSI TW

The machine is available in different versions. The figure shows an example:

- ① Blade guard ring
- ② Blade
- ③ Product fixation device, vertical
- ④ Blade cover
- ⑤ Product holder complete with remnant holder
- ⑥ Carriage
- ⑦ Carriage guide
- ⑧ Identification plate
- ⑨ Light sensor
- ⑩ Conveyor
- ⑪ Lock at belt support
- ⑫ Stand, mobile
- ⑬ External drives for conveyor belts
- ⑭ Weighing conveyor with scale
- ⑮ Gauge plate
- ⑯ Rear wall
- ⑰ Depositing arm
- ⑱ Chain frame with feed roller
- ⑲ Deflector
- ⑳ Display and operating unit with ON/OFF switch at the bottom of the machine housing (optionally on top)

2.2.4 Accessories



Only use the original Bizerba spare parts and accessories in order to ensure safe and trouble-free operations.

standard

- Instruction manual
- Accessories kit including sharpener, paper felt, cleaning cloth, scrubber with brush, Bizerba machine oil
- Aufkleber "Sharpen and Lube daily"

optional

- Stand
- Blade available in various models
- Shaving deflector

- Checkered plate for depositing table
- 4 handles for the machine
- Cover caps for the threaded holes of the handles
- Protective cover protecting against dust and dirt

2.3 Warranty

We are not responsible for damages caused by:

- Non-compliance with the instruction manual
- or unauthorized and incorrect electrical installation by the customer
- incorrect operation, utilization contrary to terms and conditions
- structural modifications, removal of protective devices
- use of replacement parts and accessory components or third-party resources that are not Bizerba originals
- natural wear and tear

In such cases, the user is acting at his own risk and is responsible for any damage occurred.

2.4 Data security

The machine may only be operated within a secured internal network. Connecting the machine with the software to the Internet when unprotected, for example, allows unauthorized access. The consequences can be: Data spying, data manipulation, damage to the machine, cancellation of production.

The software has a password protection. Change the known standard passwords during commissioning. Only secret passwords provide protection. Only disclose passwords to authorized persons and always treat them confidentially.

2.5 Disposal of the machine / environmental protection

This machine is an electronic device as per definition of the WEEE Directive.

To ensure that the machine is recycled environmentally friendly, return the machine to the manufacturer or the dealer after intended use has expired.

Naturally, Bizerba and its dealers will take back free of charge old machines no longer in operation.

Please contact your specialist in this case.

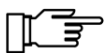



The application of these disposal regulations are based upon legal regulations of the respective country.

3 Safety instructions

The safety instructions must be observed throughout the installation, operation, cleaning and maintenance procedures.

3.1 General notes on safety





	<p>⚠ DANGER</p> <p>Damaged power supply cables or faulty protective devices! danger to life due to electric current Acute risk of injury of operating personnel.</p> <ul style="list-style-type: none"> – Damaged supply lines must be replaced immediately with new cables and installed by a professional electrical company or by Bizerba Service. – The mains cable must be routed in a way that it is no cause of risk. – Protective devices must be checked every day with regards to function before start-up. – Protective devices may not be removed, modified or bypassed.
	<p>⚠ DANGER</p> <p>Open the electrical installation area! danger to life due to electric current</p> <ul style="list-style-type: none"> – The electrical installation area may only be opened by Bizerba Service. – Pull power plug before moving the machine.
	<p>⚠ WARNING</p> <p>Unauthorized persons! Serious injuries to fingers and hands and damage to health.</p> <ul style="list-style-type: none"> – Only trained personnel over 14 years may operate, clean and maintain the machine. [▶ 6] Subsequent training to be repeated on a regular basis. – Unauthorized persons, particularly children, may not stay in the work area of the machine.

Medical information for persons with active implants





Active implants are, e. g. pacemakers or defibrillators. If a safety distance of 30 cm is maintained between field source and implant, it might be very unlikely that active implants are affected in any way.

Non-ionizing radiance is not generated intentionally, but is a technical effect caused through electrical equipment: e.g. electric motors, high-voltage cables or magnetic coils. Furthermore, the device is not equipped with strong permanent magnets.



3.2 Safety instructions for transport and installation

	<p>⚠ WARNING</p> <p>Damaged handles, threaded holes! Risk of injury if handles are not correctly fastened.</p> <ul style="list-style-type: none"> – Check handles and threaded holes for damage prior to use. – Do not use damaged handles or threaded holes. – Use handles only for lifting the machine.
	<p>⚠ CAUTION</p> <p>Carriage might move due to its unladen weight. Risk of hand injuries due to crushing!</p> <ul style="list-style-type: none"> – Be careful when unpacking.
	<p>⚠ DANGER</p> <p>Tipping hazard when improperly installed! This may result in serious injuries and damage to property.</p> <ul style="list-style-type: none"> – Installation requirements must be met. – Operate machine on stand only if its weight rests on the feet and the casters are locked. – The machine must only be moved on a level surface with a very low degree of roughness and unevenness of not more than 2 cm. – Installation, moving and operation are not permitted on surface that are not level.
	<p>⚠ WARNING</p> <p>Incorrect supply voltage! Destruction of electric components, fire hazard.</p> <ul style="list-style-type: none"> – Do not connect the machine to the power supply if the power supply data does not correspond to the machine's connection values. Mains data must be identical. – Inform Bizerba Customer Service.

3.3 Safety instructions during operation, slicing

	<p>⚠ DANGER</p> <p>Tipping hazard in case of overload! This may result in serious injuries and damage to property.</p> <ul style="list-style-type: none"> – Operate machine on stand only if its weight rests on the feet and the casters are locked. – Pay attention to max. load of machine when loading products. [▶ 110] – The machine must only be operated with the product securely fastened in the carriage. – The product weight shown in the status bar must not be exceeded.
	<p>⚠ WARNING</p> <p>Rotating blade! Cut injuries.</p> <ul style="list-style-type: none"> – Do not allow yourself to become distracted. Concentrate on the task in hand and avoid time pressure. – During operation, do not reach into the path of the carriage. – Never push product ends towards blade by hand.
	<p>⚠ WARNING</p> <p>Moving components! Risk of entanglement, shearing, crushing and being hit.</p> <ul style="list-style-type: none"> – Do not wear loose clothing or wear hair down. – Do not reach into paths of carriage, product holder, gauge plate, depositing system, conveyor and depositing table. – Only clean machine when switched off and power plug is pulled.
	<p>⚠ CAUTION</p> <p>There are spikes on the product holder! Driver hooks on feed carriage, grip hooks! Risk of injury.</p> <ul style="list-style-type: none"> – Use handle when working with product holder. – Claws are lowered into a rest position.

3.4 Safety instructions for sharpening, cleaning

	<p>⚠ WARNING</p> <p>Unprotected blade! Coming in contact with the sharp blade can lead to serious injuries.</p> <ul style="list-style-type: none"> – Always wear cut-proof gloves during the cleaning and sharpening procedures and shoes with toe caps when the blades are replaced. – Do not clean the blades when operating the machine.
	<p>⚠ WARNING</p> <p>Chain spikes, driver spikes of feeding carriage, gripper hooks, deflector edge! Stab and cut wounds.</p> <p>Twisted guide cam or chain spikes can cause malfunctions.</p> <ul style="list-style-type: none"> – Always wear cut-proof gloves when cleaning. – Avoid touching the chain spikes. – Claws are lowered into a rest position.
	<p>⚠ WARNING</p> <p>Missing components! The operator can only be protected from injuries and the machine protected against damage if all the components of the machine are assembled properly.</p> <ul style="list-style-type: none"> – Check if the machine is complete before it is re-started. – Check if components are positioned correctly and firmly. – Only use original Bizerba spare parts and accessories.

3.5 Protective and safety devices

- Blade guard ring, stationary, cannot be removed
- Blade cover stationary, removable
- Gauge plate, covering carriage stroke area
- Rear wall, cannot be removed
- Stand casters
- Protective cover of chain frame and working area of depositing arm
- Automatic switch-off when drive system is overloaded
- Automatic switch-off of blade and carriage drive when in product loading position
- Cleaning program, locked machine setting

- Sharpening program, locked machine setting

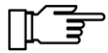

Remaining risks that cannot be excluded by technical measures:

- Risk of tripping/slipping if the work area is not kept tidy.
- Risk of injury if the required personal protective clothing is not worn.

3.6 System design related residual hazards

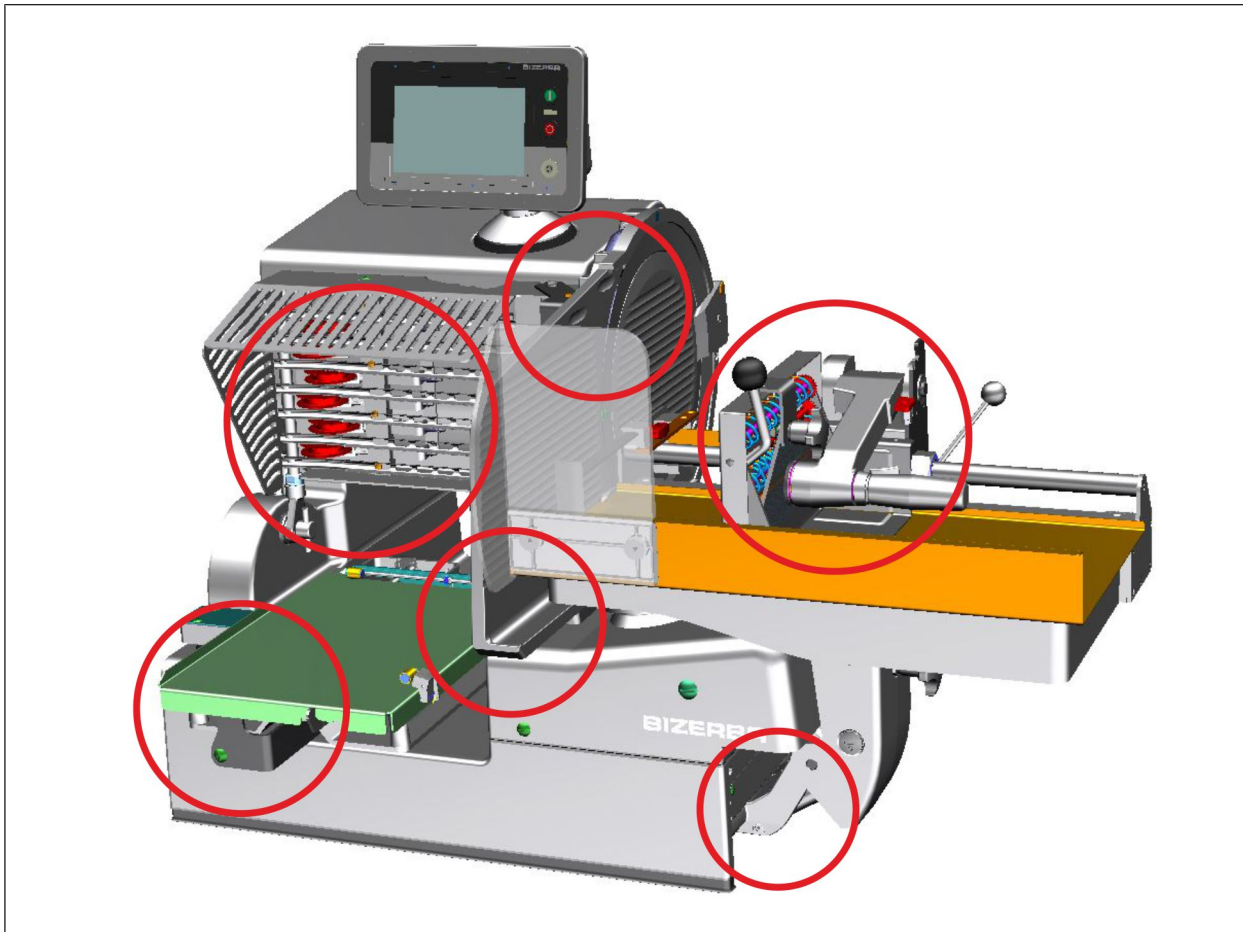

Fig. 4: VSI W

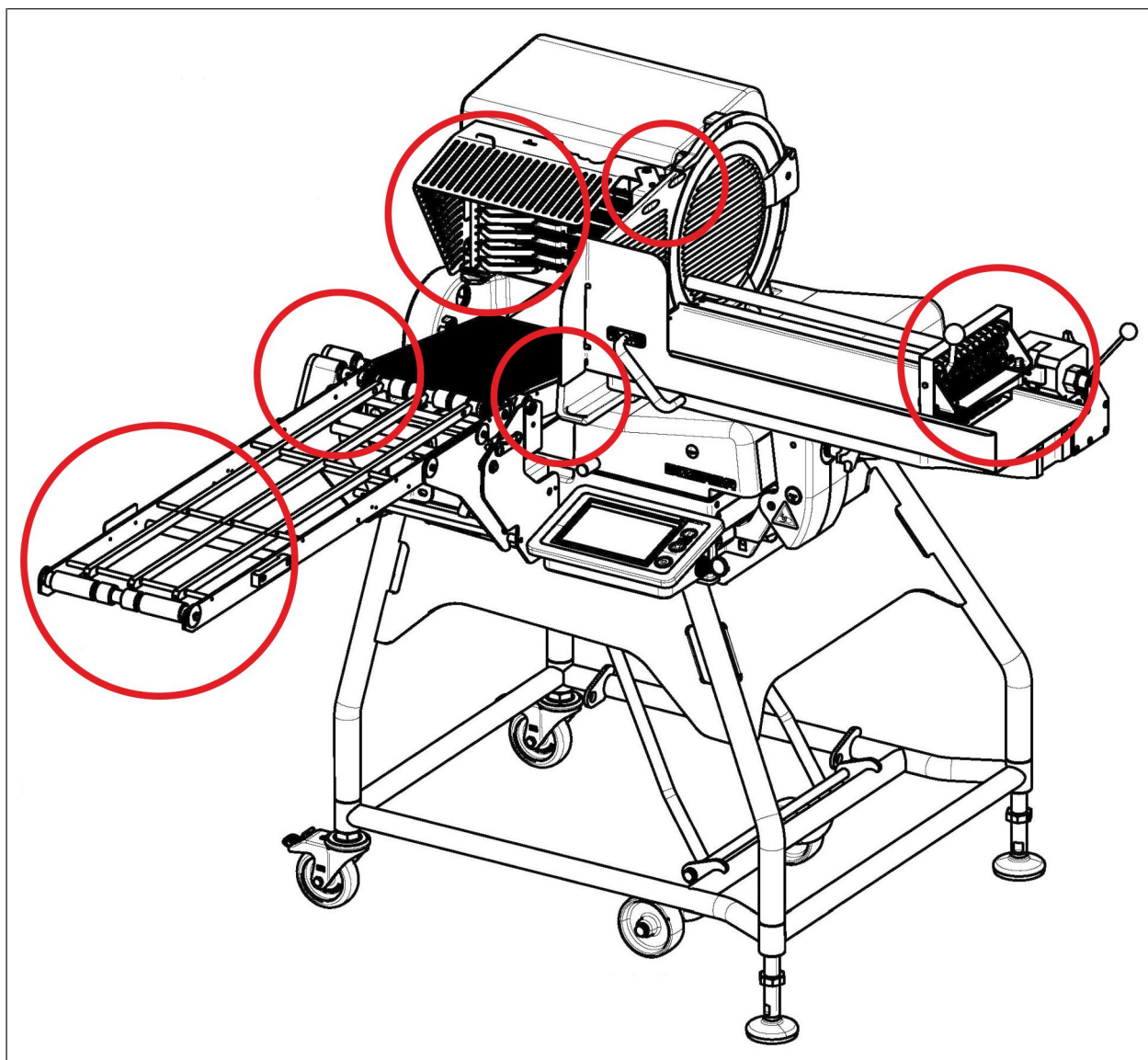
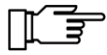

Fig. 5: VSI TW

4 Installation

4.1 Unpacking instructions



When transporting the machine, wear shoes with toe caps and use suitable lifting devices.

At least four people are needed to move the machine. Weight of machine is higher than 100 kg.



⚠ WARNING

Damaged handles, threaded holes!

Risk of injury if handles are not correctly fastened.

- Check handles and threaded holes for damage prior to use.
- Do not use damaged handles or threaded holes.
- Use handles only for lifting the machine.

- Machine is still in packaging.

- ⇒ Insert the four handles [▶ 15] in the drill holes provided and finger tighten them manually.
- ⇒ Four persons are needed to lift the machine out of its packaging and transport it to the installation site. Pay attention to the center of gravity of the machine.

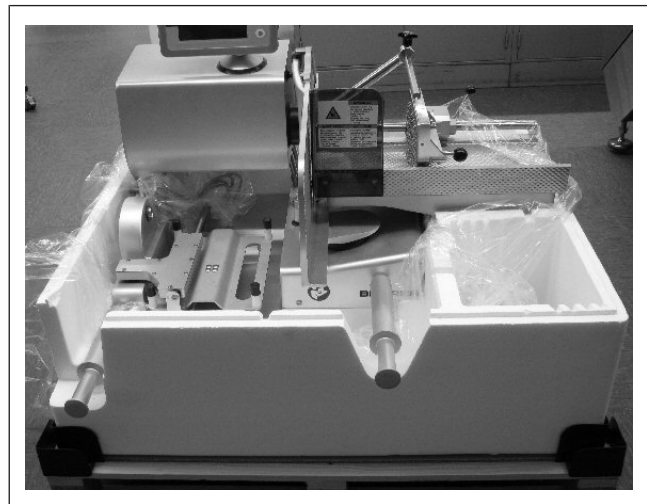

Fig. 6: Handles, front

- ⇒ After positioning remove handles.
- ⇒ Cover drill holes with the cover caps provided.

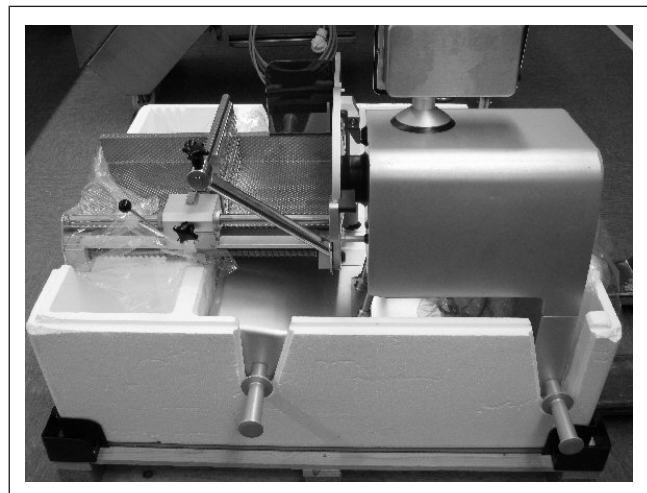

Fig. 7: Handles, rear

4.2 Transport and storage

The machine has to be transported and stored in accordance with the symbols on the packaging.

Before installation, store and transport the machine in the original packaging. We recommend keeping the original packaging.

WARNING! Tipping hazard.

The machine with stand must only be moved on level surfaces with a very low degree of roughness and unevenness of not more than 2 cm.

The machine must not be moved during operation.

Unplug power plug before moving the machine!

4.3 Installation and assembly

Installation, start-up, as well as instructions on how to operate, clean, maintain and service the device are provided for the first time by the relevant Bizerba customer services.

- ⇒ Only lift machine out of its packaging by using the handles. [▶ 23]
- ⇒ Do not hold onto gauge plate, carriage, support for weighing conveyor and conveyor belt. This applies to the installation and any local change of the machine.

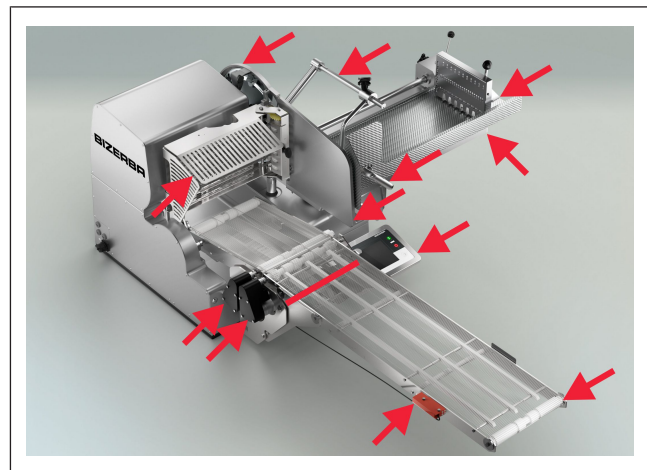



Fig. 8: Prohibited stop points

	⚠ CAUTION
	<p>Risk of crushing! Carriage might move due to its unladen weight.</p> <p>– Be careful when unpacking.</p>

4.3.1 Installation requirements

Safe operation of the slicer within the standards and guidelines is ensured on the Bizerba stand. Stand and slicer bear a CE mark (or UL/cUL mark within the area of application). The integrated scale can only be reliably used with the Bizerba stand.

Alternatively the slicer can be installed on torsion-resistant furniture which is suitable for the weight of the machine. In this case, the user is responsible for safe operation and reliable use of the integrated scale.

The installation surface must be:

- large enough [▶ 110]

- level and even (variation from horizontal max. 1 degree)
- slip-proof and tilt-proof
- stable and firm [► 110]

Recommended table height is approx. 800 mm.

Make sure there is a safety distance of 100 mm between the machine (max. work area) and the wall if machine is installed on a table, and of 500 mm if machine is installed on a stand.

4.3.2 Position on stand

Installation as well as instruction on how to operate the stand are initially provided by the Bizerba service.

	⚠ DANGER
	<p>Tipping hazard when improperly installed! This may result in serious injuries and damage to property.</p> <ul style="list-style-type: none">– Installation requirements must be met.– Operate machine on stand only if its weight rests on the feet and the casters are locked.– The machine must only be moved on a level surface with a very low degree of roughness and unevenness of not more than 2 cm.– Installation, moving and operation are not permitted on surface that are not level.

- ⇒ Put weight on mobile stand's feet by lifting the wheels.
- ⇒ Lock casters.

CAUTION! Crushing hazard when lowering the wheels.

- ⇒ Use bracket ① to lift and lower wheels.
- ⇒ Position machine on stand.
- ⇒ Fasten machine using the enclosed screws according to drawing.

Leveling

In order to ensure the scale's accuracy, machine must be installed horizontally.

- ⇒ Turn feet of the stand ② until the bubble moves to the center of the spirit level ③. Machine is installed horizontally.

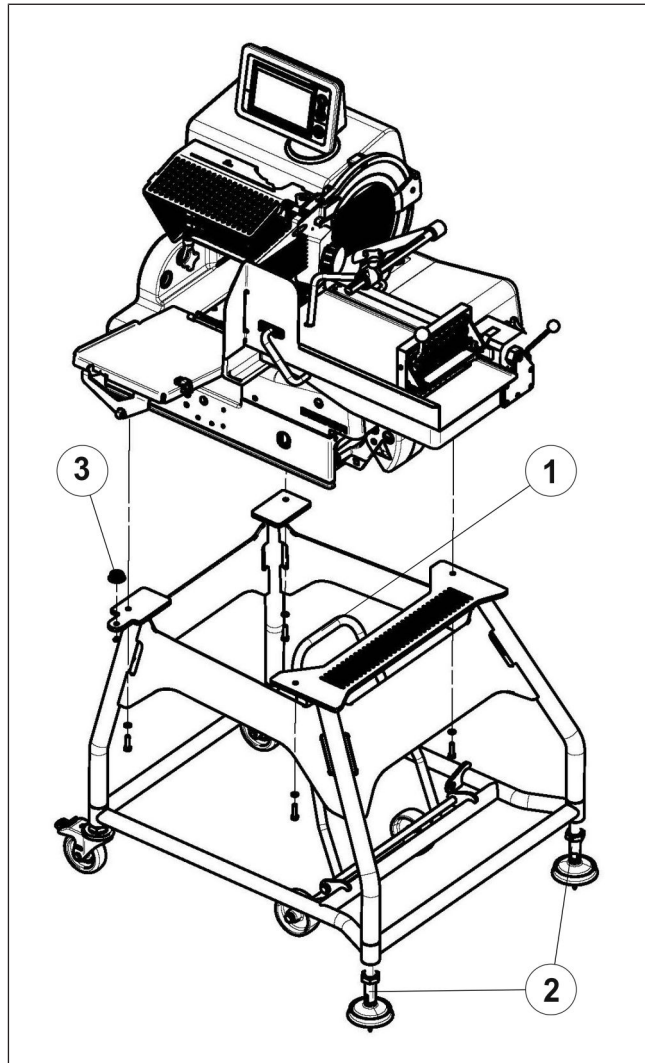
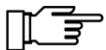

Fig. 9: Installation and leveling



Re-level scale after each change of location.

4.3.3 Electrical connection

Information on identification plate

Bizerba logo	BIZERBA
Machine type	Model VSI330 F / VSI330 F W / VSI330 F T / VSI330 F TW
Machine description	Slicer
Machine number	...
Production code	X-..
IP rating	IPX5
Maximum load of scale	Max 2kg / Max 4lbs
Scale interval	d=0,001kg / d=0,002lbs
Electrical data	see identification plate
Manufacturer's address	Bizerba SE & Co. KG Wilhelm-Kraut-Str. 65 72336 Balingen, Germany

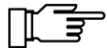

Check before mains connection

Before you connect the machine, check the electric data on the rating plate with the mains data about the power supply.

	⚠ WARNING
	<p>Incorrect supply voltage! Destruction of electric components, fire hazard.</p> <ul style="list-style-type: none"> – Do not connect the machine to the power supply if the power supply data does not correspond to the machine's connection values. <p>Mains data must be identical.</p> <ul style="list-style-type: none"> – Inform Bizerba Customer Service.

Installation of power supply provided by customer

The installation of the power supply to connect our machines must be carried out in accordance with country-specific regulations and rules derived thereof. These essentially include the recommendations of at least one of the following commissions:

- International Electro-technical Commission (IEC)
- European Committee for Electro-technical Standardization (CENELEC)

The machine has been built according to Protection Type I and has to be connected to the protective conductor.

Measures for suppressing interference:

With severely contaminated mains supplies (e.g. when "thyristor-controlled systems" are used) measures must be taken on-site to suppress interferences, e.g.:

- A separate supply line must be planned for Bizerba machines.
- In problem cases, install capacitively decoupled isolating transformers or other suppressors into the supply mains prior to Bizerba machines.

Availability of the power plug used as a supply circuit disconnect

Make sure that any access point allows you to check whether the plug is disconnected.

4.4 Start-up

Initial start-up as well as instructions on how to operate, clean, maintain and service the machine are initially provided by the responsible Bizerba service department.

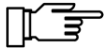
Use of lubricants in the production process.

Substances not intended to get in contact with food could be present on the surfaces of the machine.

- Clean thoroughly before start-up. [▶ 76]

4.4.1 Switching the slicer on

- ⇒ On the display and operating unit press the <ON switch>.

White signal lamp lights up, supply voltage is applied.

The display becomes active.

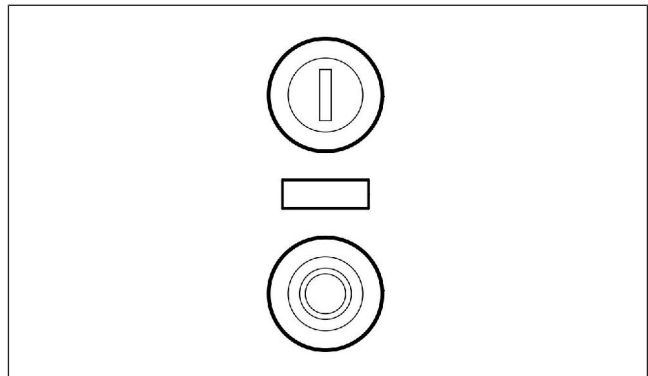

Fig. 10: ON/OFF switch

Machine carries out a system check. On the information bar the required steps are listed. Successfully completed steps receive a check mark.

⇒ Press <Execute> on the display and operating unit after initialization.

Machine moves to zero position.

The individually configured operator page (main page) is loaded.

Machine comes to a standstill if not all check marks could be set.

⇒ Switch off machine, wait 5 seconds and switch machine back on again.

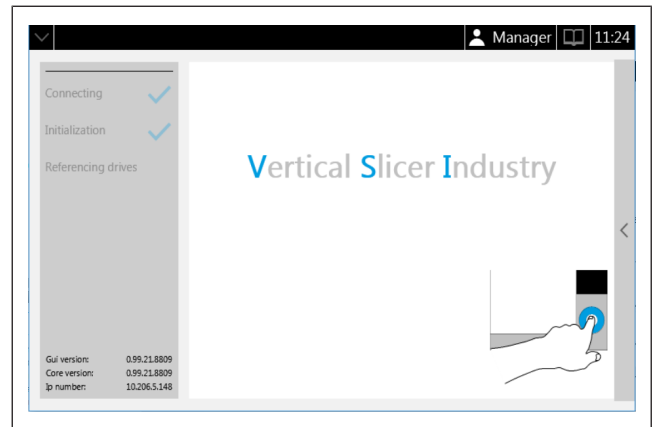

Fig. 11: Home page

4.4.2 Switching the machine off

⇒ Press red key <O>. (reduced operating force)

Blade is switched off.

⇒ Remove the AC power plug.

Machine is switched off.

4.5 Decommissioning

If the machine is not going to be used for a longer period of time:

⇒ Switch off machine.

⇒ Pull out power plug.

⇒ Clean machine as per cleaning instructions.

5 Machine and operating elements

5.1 Display and operating unit

The slicers are operated via a touch screen.

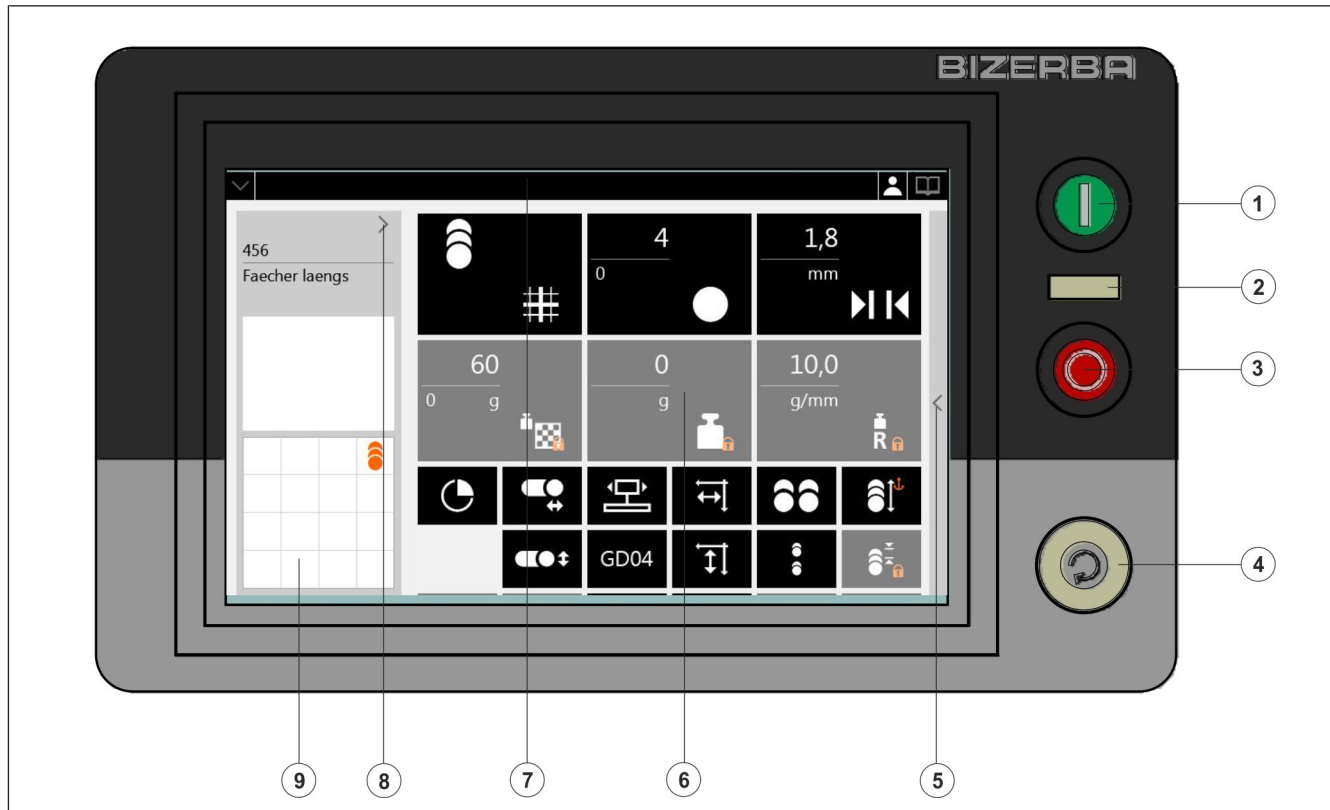

Fig. 12: Display and operating unit

- ① <ON switch> (green)
- ② LED (white) lights up when machine is switched on
- ③ <OFF switch> (red) reduced operating force
- ④ <Execute> selected action (e.g. slicing, cleaning, sharpening, start and stop respectively, pause)
- ⑤ To show the navigation bar, press the arrow or wipe in arrow direction
- ⑥ Touch screen
- ⑦ Status bar
- ⑧ To open the PLU menu, press the arrow or wipe in arrow direction
- ⑨ Information bar

5.2 Icons on the touchscreen

Not all functions are available for all variants.

Navigation bar:



Home

After pressing the icon, the individually configured operator page (main page) comes up on the touchscreen.



Parameter

After pressing the icon, the operator page with all parameters (parameter page) comes up on the touchscreen.



Sharpening

After pressing the icon, notes on the further operating procedure appear on the touchscreen.



Cleaning

After pressing the icon, notes on the further operating procedure appear on the touchscreen.



Settings

After pressing the icon, the page for various settings comes up on the touchscreen.

Settings:



Machine settings



Software settings



Operator settings



Setting of language for user guidance



Slicing program



Products



Depositing area or packaging, where the sliced product is to be deposited



Depositing type

Selectable are:

- Stacking
- Shingling lengthwise
- Shingling crosswise
- Circular pattern
- Shaving
- Vector graphic

Filter characteristic in the search mask.

PLU menu:



Save PLU



Save PLU as



Delete PLU



Search PLU



Load / open PLU



Enter / Next



Confirm / Accept



Cancel / Refuse



Empty all input fields of the search mask

5.2.1 Parameter symbols

Information on product



Product ID



Name of product



Product height

Specifies the product height in mm. Required for the calculation of the depositing pattern.



Product width

Specifies the product width in mm. Required for the calculation of the depositing pattern.



Product length

Specifies the product length in mm. This is required in order to calculate the reference weight and to determine the end position of the product holder.



Product profile <PC03>

Describes the profile of the product. This is required in order to calculate the reference weight.



Calibrated product

Slightly uncalibrated product



Heavily uncalibrated product



Product weight

Specifies the product weight in kg or lb. This is required in order to calculate the reference weight.



Reference weight

The reference weight represents the volume weight of the product to be sliced. This is specified in g/mm or lb/mm and is needed for slicing by target weight.

Information on depositing area



Deposit area width

Specifies the width of a package in mm.

 Depositing area length
Specifies the length of a package in mm.

 Depositing area height
Specifies the height of a package in mm.

Information on slicing program

 PLU No.
Unique number of slicing program.

 PLU name
Name of slicing program.

 Depositing type Stacking

 Depositing type Shingling crosswise

 Depositing type Shingling lengthwise

 Depositing type Circular pattern

 Depositing type Shaving

 Depositing type Vector graphic

 Depositing offset crosswise
Specifies the start point for crosswise depositing.

 Depositing offset lengthwise
Specifies the start point for lengthwise depositing.

 Number of slices
Specifies the number of slices per row.

 Slice thickness
The slice thickness equals the thickness of the product slice.



Product feed offset

Current slice thickness is changed by this value.



Staggered stack crosswise

Specifies the offset by means of which every second slice is deposited to the left (if product dimensions are entered correctly).



Stack depositing correction step correction factor

Correction factor for correction step during stack depositing. Optimizes the depositing quality of the stacks in case of special products to be sliced.



Shingling distance, shingling lengthwise

The distance between slices within a shingle.



Shingling distance, shingling crosswise

The distance between slices within a shingle.



Number of layers

Specifies the number of repetitions of a depositing pattern. The result is a stack of the selected depositing pattern.



Shingling length, shingling crosswise

Specifies the length of the entire shingle.



Shingling length, shingling lengthwise

Specifies the length of the entire shingle.



Circular diameter

Specifies the outer circle diameter for circular pattern.



Target weight

Specifies the weight per row in the selected SI unit (g or lb).



Number of rows crosswise

Specifies the number of shingle rows deposited in running direction in a portion.











Row = stacking



Number of rows crosswise

Specifies the number of shingle rows deposited in running direction in a portion.

Row = shingling lengthwise

	<p>Number of rows crosswise Specifies the number of shingle rows deposited in running direction in a portion. Row = shingling crosswise</p>
	<p>Number of rows lengthwise Specifies the number of shingle rows deposited crosswise to the running direction in a portion. Row = stacking</p>
	<p>Number of rows lengthwise Specifies the number of shingle rows deposited crosswise to the running direction in a portion. Row = shingling lengthwise</p>
	<p>Number of rows lengthwise Specifies the number of shingle rows deposited crosswise to the running direction in a portion. Row = shingling crosswise</p>
	<p>Row spacing crosswise, stacks Specifies the distance between crosswise deposited stacks in the portion (if product dimensions are entered correctly).</p>
	<p>Row spacing crosswise, shingles lengthwise Specifies the distance between crosswise deposited shingles lengthwise in the portion (if product dimensions are entered correctly).</p>
	<p>Row spacing crosswise, shingles crosswise Specifies the distance between crosswise deposited shingles crosswise in the portion (if product dimensions are entered correctly).</p>
	<p>Row spacing lengthwise, stacks Specifies the distance between lengthwise deposited stacks in the portion (if product dimensions are entered correctly).</p>
	<p>Row spacing lengthwise, shingles lengthwise Specifies the distance between lengthwise deposited shingles lengthwise in the portion (if product dimensions are entered correctly).</p>
	<p>Row spacing lengthwise, shingles crosswise Specifies the distance between lengthwise deposited shingles crosswise in the portion (if product dimensions are entered correctly).</p>
	<p>Number of portions Specifies the number of portions per slicing program.</p>

Other parameters

	<p>Gauge plate offset</p> <p>Clearance which is additionally needed for the gauge plate to open or close during slicing.</p>
	<p>Light sensor</p> <p>Activation switch for light sensor at conveyor belt.</p> <p>Off/On</p>
	<p>Blade speed</p> <p>Specifies the speed of rotation of the blade in U/min.</p>
	<p>First Cut Program</p> <p>The first cut program serves to cut the first slices of a fed product and to keep them separate from subsequent regular portions.</p>
	<p>First cut discharge</p> <p>The first cut discharge serves to discharge the slices from the first cut program. (machine with conveyor belt)</p>
	<p>Speed Discharge</p> <p>Specified the speed at which the sliced product is transported.</p>
	<p>Number of carriage strokes</p> <p>Specifies the number of carriage strokes per minute.</p>
	<p><Clear conveyor belt key></p>

Status of the parameter

	<p>Parameter is fixed and can not be changed by parameter validation or other processes of the machine control (e.g. slicing of target weight). The parameter can be changed by the operator (if all the other requirements are met).</p>
	<p>The parameter of the currently loaded PLU has been edited.</p>
	<p>Parameter is disabled. Input mask cannot be opened. Parameter cannot be changed.</p>
	<p>Parameter is visible on the individually configured operator page (main page).</p>

5.2.2 Anchor symbol

The small colored anchor  on the tiles of the parameters <Number of slices>, <Slice thickness>, <Shingling length> or <Shingling distance> means that the corresponding parameter is fixed.

For the parameters <Number of slices> and <Slice thickness> the anchor symbol is only visible for devices with scale. If the scale is switched off no anchor is displayed.

If the anchor is set to the number of slices, it will be set back automatically for the slice thickness and vice versa.

The number of slices is fixed.

In order to obtain the preset portion weight, the slice thickness is changed during slicing.

The slicing of the preset number of slices is carried out. Enter at least 4 slices for optimum weight control.

Portions can be cut precisely in accordance with the target weight with this technique.

If the anchor is set to the number of slices, then the slice thickness can not be changed. The numeric input field and the up-/ down keys are grayed out and disabled for operator entry.

The slices vary in thickness.

The slice thickness is fixed.

As many slices are cut as required to reach or exceed the target weight.

The slice thickness does not change which means that all slices are of equal thickness.

Less accurate procedure.

If the anchor is set to the slice thickness, then the number of slices can not be changed. The numeric input field and the up-/ down keys are grayed out and disabled for operator entry.

Shingling length is fixed.

In order to obtain the preset shingling length, the shingling distance is reduced or increased.

If the anchor is set to shingling length, the shingling distance can not be changed. The numeric input field and the up-/ down keys are grayed out and disabled for operator entry.

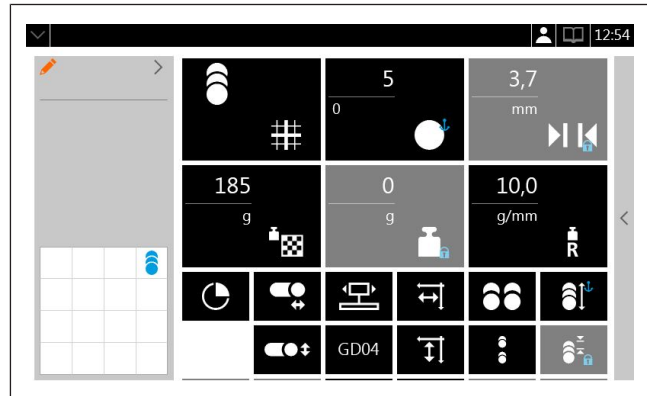

Fig. 13: Anchor set to number of slices

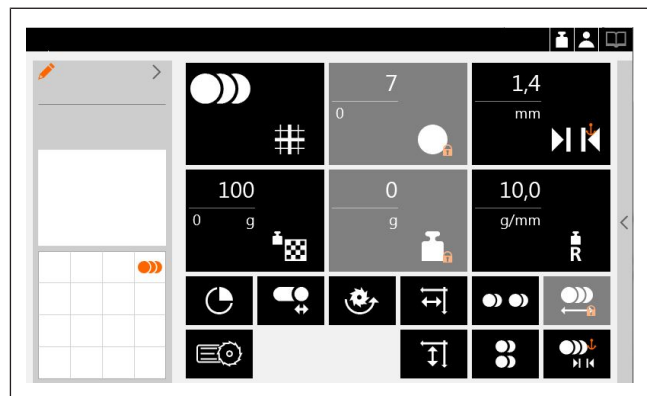

Fig. 14: Anchor set to slice thickness

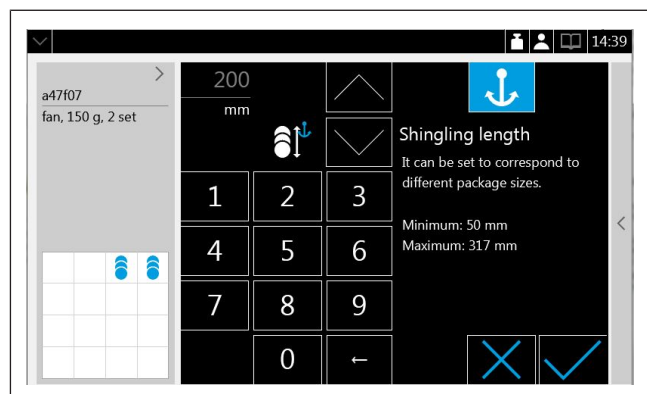

Fig. 15: Anchor is set to shingling length

The shingling distance is fixed.

In order to obtain the preset shingling distance, the shingling length is reduced or increased.

If the anchor is set to shingling distance, then the shingling length can not be changed. The numeric input field and the up-/ down keys are grayed out and disabled for operator entry.

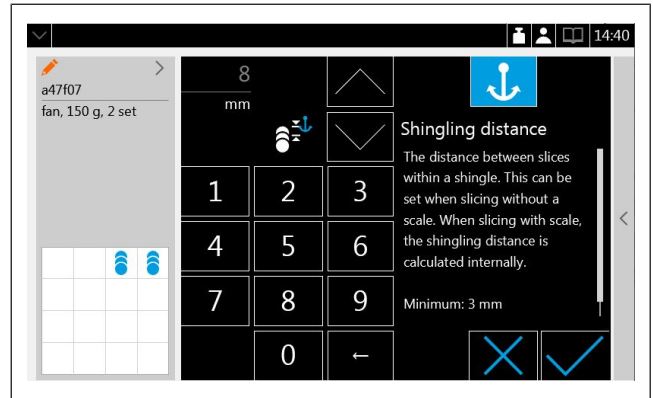
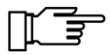

Fig. 16: Anchor set to shingling distance

If the anchor is set to shingling length, it will be set back automatically for the shingling distance and vice versa.



If the number of slices required to reach the target weight does not fit the depositing belt, the portion is discharged as Underweight.

5.2.3 Depositing patterns



Stacking

The sliced product is deposited on top of each other and forms one or more stacks.

The overall pattern may consist of several stacks and equals a portion. The depositing table has room for only one portion.

Several parameters influence the look of the depositing pattern:

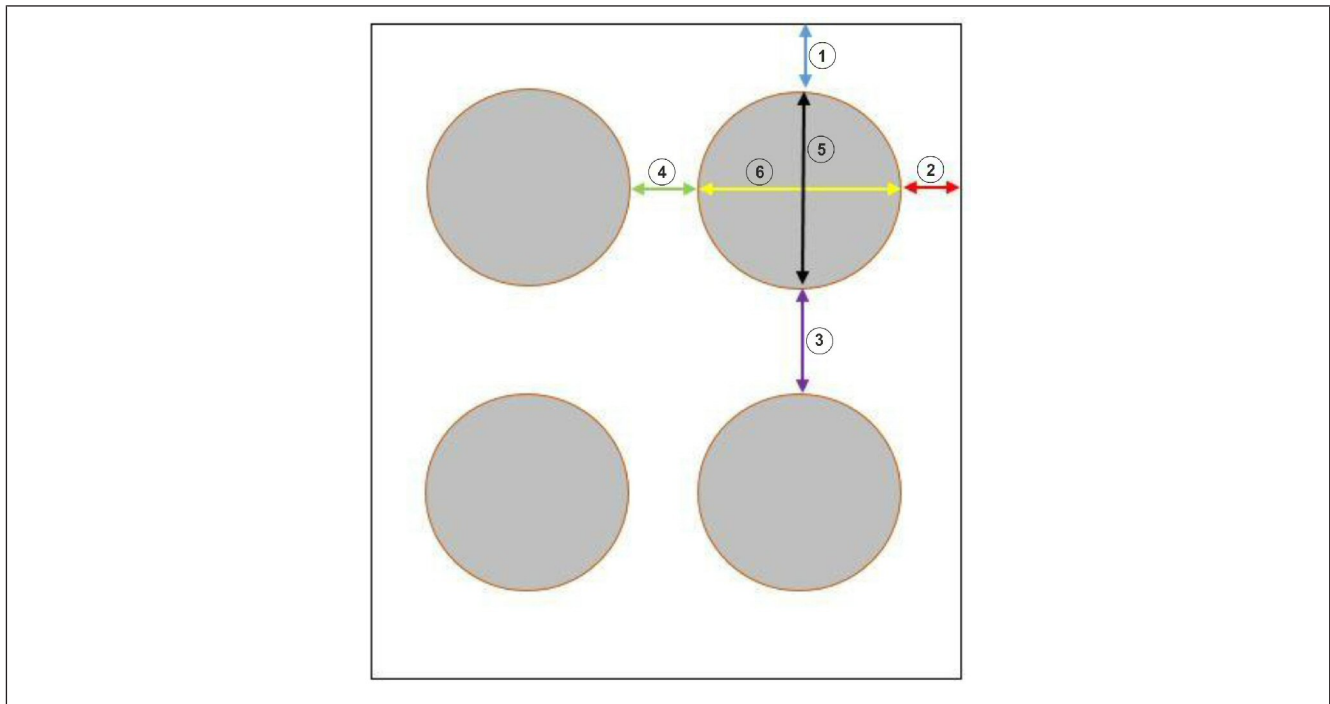

Fig. 17: Depositing pattern stack

- ① Depositing offset lengthwise
- ② Depositing offset crosswise
- ③ Row spacing lengthwise, stacks
- ④ Row spacing crosswise, stacks
- ⑤ Product height
- ⑥ Product width



 **Shingling lengthwise**

The sliced product is offset on top of each other and forms one or more shingles parallel to the blade.

The overall pattern may consist of several shingles lengthwise and equals a portion. The depositing table has room for only one portion.

Several parameters influence the look of the depositing pattern:

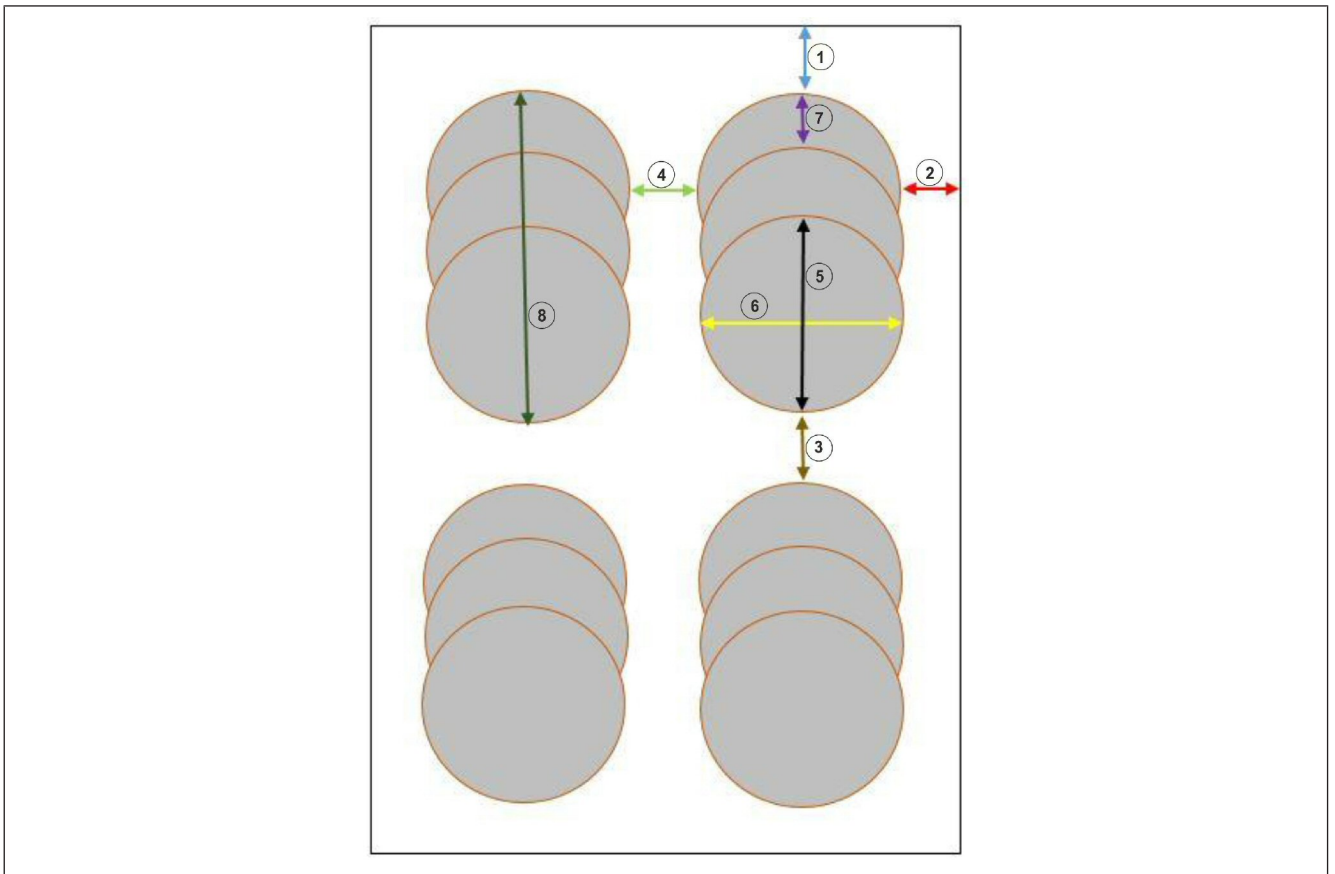

Fig. 18: Depositing pattern shingling lengthwise

- | | | |
|---|---|--|
| ① | Depositing offset lengthwise | |
| ② | Depositing offset crosswise | |
| ③ | Row spacing lengthwise, shingles lengthwise | |
| ④ | Row spacing crosswise, shingles lengthwise | |
| ⑤ | Product height | |
| ⑥ | Product width | |
| ⑦ | Shingling distance | |
| ⑧ | Shingling length | |

●● Shingling crosswise (not available for all variants)

The sliced product is offset on top of each other and forms one or more shingles parallel to the depositing system.

The overall pattern may consist of several shingles crosswise and equals a portion. The depositing table has room for only one portion.

Several parameters influence the look of the depositing pattern:

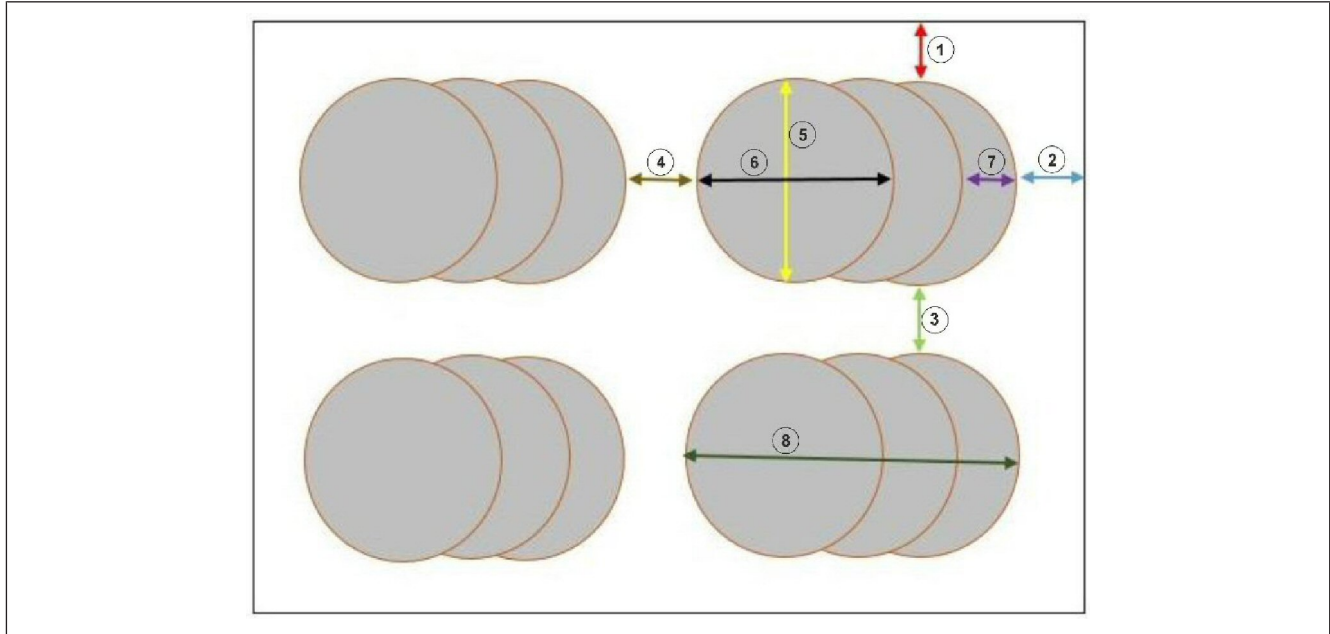

Fig. 19: Depositing pattern shingling crosswise

- | | | |
|---|--|--|
| ① | Depositing offset lengthwise | |
| ② | Depositing offset crosswise | |
| ③ | Row spacing lengthwise, shingles crosswise | |
| ④ | Row spacing crosswise, shingles crosswise | |
| ⑤ | Product height | |
| ⑥ | Product width | |
| ⑦ | Shingling distance | |
| ⑧ | Shingling length | |



Circular pattern (not available for all variants)

The sliced product is offset on top of each other and forms one or more circles.

The overall pattern consists of 1 - 3 circles with variable diameter. This pattern can form multiple layers and corresponds to one portion. The depositing table has room for only one portion.



Note: In case of many layers, the max. stack height could be exceeded without the machine switching off. In this case, the number of layers has to be manually reduced.

Several parameters influence the look of the depositing pattern:

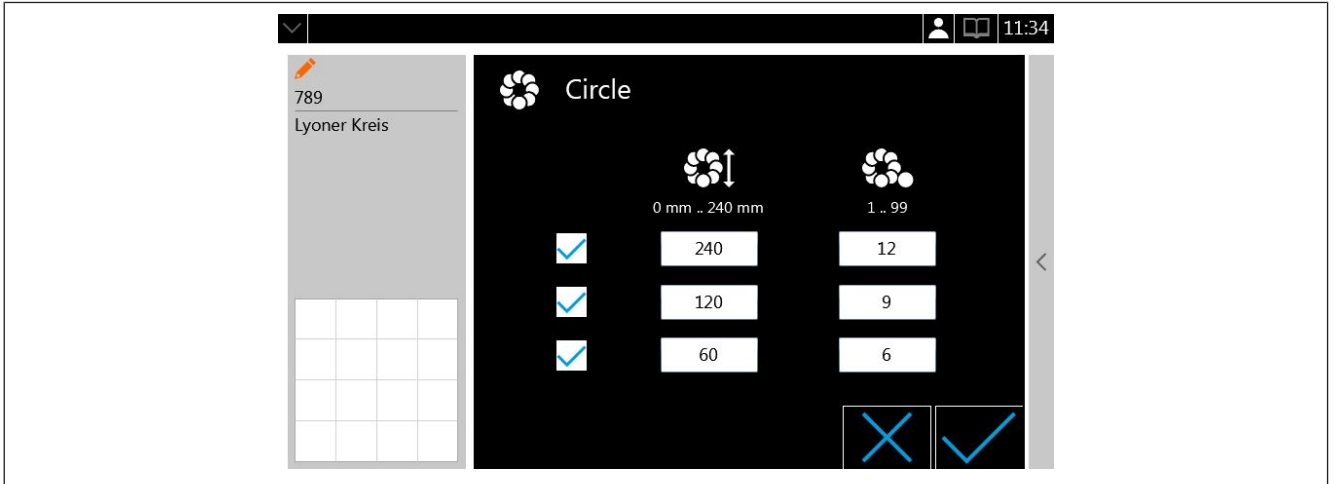

Fig. 20: Circular pattern default values

Depositing offset lengthwise



Depositing offset crosswise



Circular diameter



Number of slices in the circle



Number of layers



Product height



Product width



By adjusting the distance of slices, the number of slices for each circle are distributed evenly.

Target weight:

The target weight refers always to one layer.

If circular pattern is active, the anchor must always be set to number of slices. The tile number of slices is grayed out and displayed with lock icon and anchor.

The tile slice thickness is grayed out and displayed with lock icon. The device automatically sets the slice thickness possible in order to reach the target weight.

Shaving

The sliced product forms a pile of loosely falling slices. For this purpose you need a shaving deflector (optional accessories).

In order to mount the shaving deflector to the chain frame the depositing arm must first be disassembled. [▶ 77]



Fig. 21: Shaving

The depositing type shaving has the same functionality as the depositing type stacking. The default values for shaving correspond to the values for stacking.

	NOTICE
	<p>Due to the uncontrolled depositing of slices during shaving, the max. stack height could be exceeded without the machine switching off.</p> <p>In this case, the user has to reduce the number of slices manually.</p>

5.3 Paper holder

The paper holder is used for machines with depositing table when the sliced product should be placed onto paper or film.

Positioning of several sheets of paper or film:

- ➔ Using your thumb, press lever to the right against spring pressure until it clicks into place.
- ➔ Push the stack underneath the open holder.
- ➔ Release the lever by pressing the top of it lightly out of the locked position.



Fig. 22: Paper holder

Removing of deposited portions and paper:

- ⇒ Using your thumb, press lever slightly to the right; at the same time pull top-most piece of paper with portion under the open holders.
- ⇒ Release lever.

5.4 Product fixation device

The properly applied product fixation device holds the product in position during slicing preventing the product from deflecting and tipping over.

Product fixation device, vertical (carriage 400 mm and 600 mm)

The product fixation device is guided on a shaft and can be moved across the full width of the carriage. This way, it can be positioned on any product size.

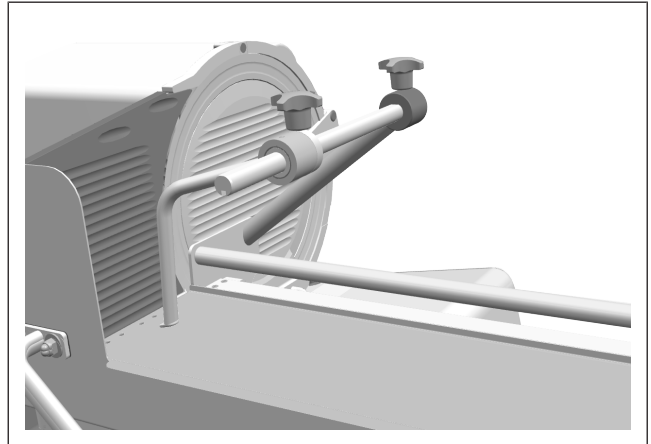

Fig. 23: Product fixation device, vertical

6 Operation

6.1 Log in operator

- Machine is switched on, system check was successful. [▶ 28]

- ⇒ Click into the operator field.
The input keyboard is shown.
- ⇒ Enter name of operator.
Regular operators can also select the name via <Touch-Down>.
- ⇒ Click into the password field.
- ⇒ Enter password and confirm.

or

- ⇒ Press <Automatic login>.

The main page is loaded with the parameters which were saved last before the machine was switched off.

Switching the keyboard to other languages

- ⇒ Press and hold the button on the left for 3 seconds.
A direct selection of the keyboard language is possible.

or

- ⇒ Briefly press the button on the left.
The keyboard switches to the next language.

During a keyboard switchover, the new keyboard remains until the next switchover.

When starting the machine the keyboard of the language set under  will be determined. If no keyboard exists for this language, the English keyboard will be used as a standard keyboard.

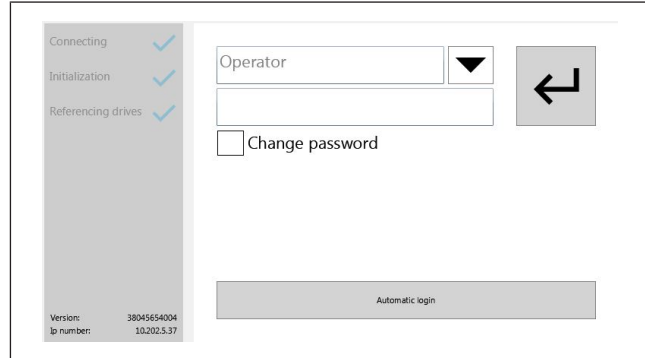

Fig. 24: Log in operator

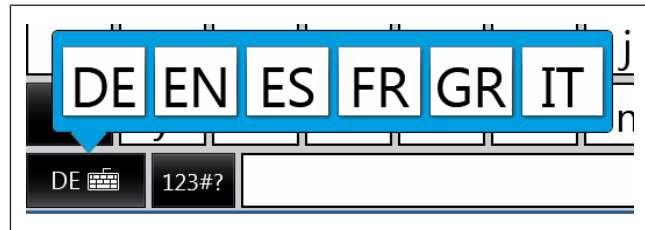

Fig. 25: Switching of the keyboard

6.2 Main page (individually configured operator page)

After successful system check and operator login the main page is loaded with the parameters which were saved last before the machine was switched off.

The status bar on top shows the progress of the slicing process, registered operators, warnings and pending orders.

The information bar on the left shows name and description of the current slicing program.

Definition of tapping:

Tap: < 1.5 seconds

Tap and hold: > 1.5 seconds

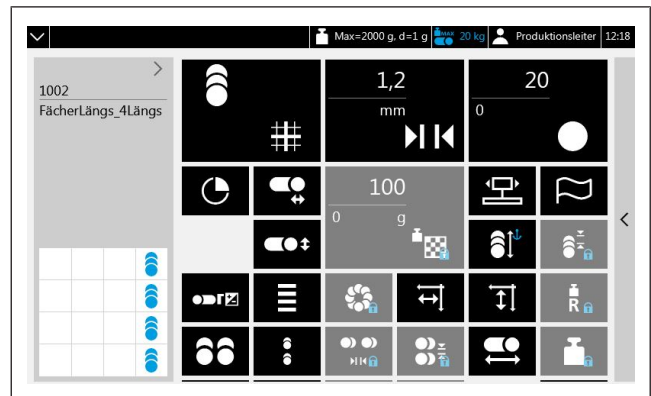

Fig. 26: Main page

⇒ Tap a tile.

The value of the parameter may be changed.

⇒ Enter value directly or change value step by step using the Up/Down keys.

⇒ Tap <Confirm> to adopt the changes and to start the parameter validation.

If the validation was successful the main page is displayed.

or

⇒ Tap <Cancel> to discard the change.

⇒ Tap and hold tile for a while.

Opens the tile manager. The tiles may be changed in size, moved or removed.

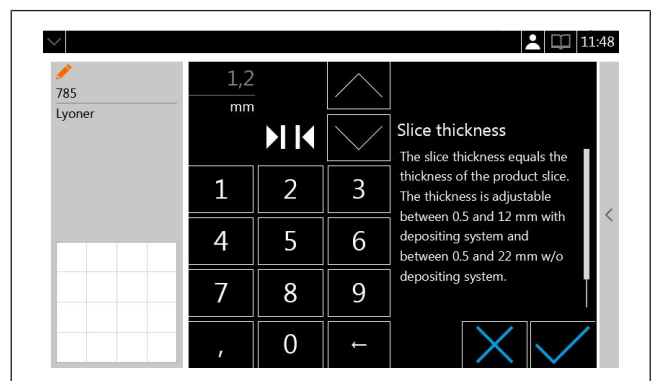

Fig. 27: Edit parameters

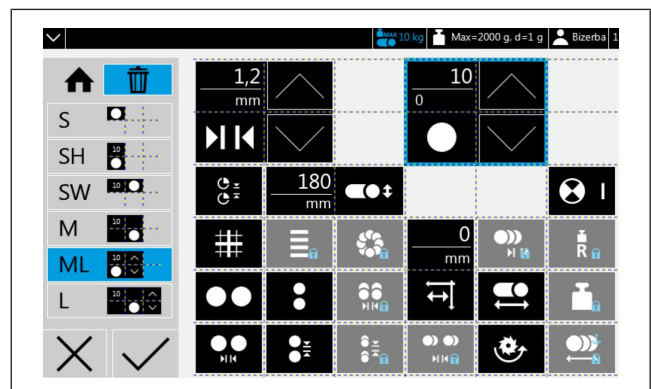

Fig. 28: Tile manager

6.3 Navigation between the pages

By tapping the icons of the navigation bar you may switch between the pages.

⇒ Using your finger, wipe from right screen edge to center.

or

⇒ Tap the arrow.

The background will be grayed out. The navigation bar will be shown.

The operator can access the individually configured operator page including all parameters, the menus for sharpening, cleaning and settings.

The active icon is white.

⇒ Pressing the lock symbol locks the screen.

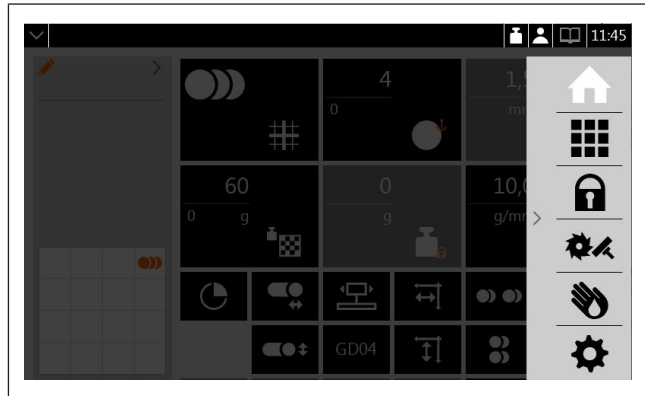



Fig. 29: Navigation bar

6.4 Parameter page

The parameter page can be called up from the navigation bar via the  icon.

Here, the parameters shown on the main page can be defined.

The small colored symbols on the tile show the status of a parameter.

Grayed out parameters are not relevant for this PLU. Vertical scrolling possible.

Definition of tapping:

Tap: < 1.5 seconds

Tap and hold: > 1.5 seconds

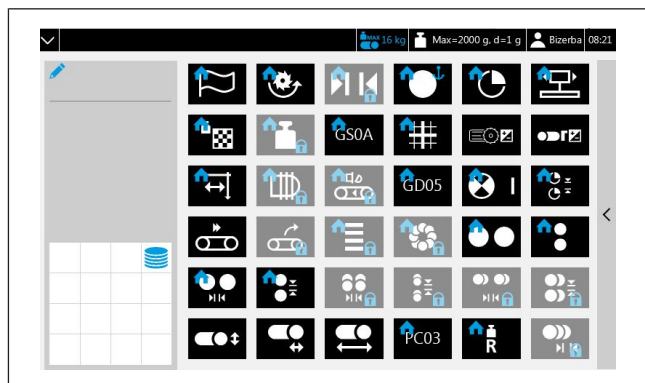

Fig. 30: Parameter page

⇒ Tap a tile.

The value of the parameter may be changed. [▶ 47]

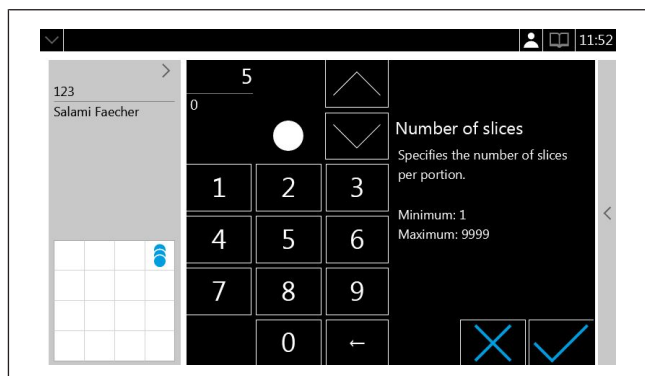

Fig. 31: Modify value

- ⇒ Tap and hold tile for a while.
- ⇒ Checkmark.
The parameter is displayed on the main page.
- ⇒ Remove checkmark.
The parameter is not displayed on the main page.

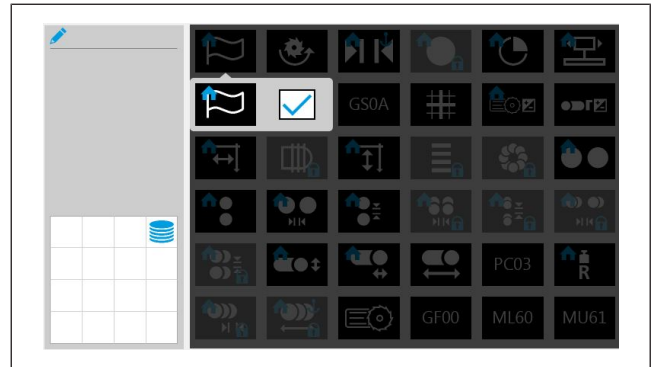

Fig. 32: Tile manager

6.5 Tile manager

The tile manager includes the tile settings. It opens by tapping and holding a tile. On the parameter page, the parameters shown on the main page can be defined. On the parameter page, the size of the tile may be changed.

Tile sizes S, SH, SW, M, ML, L may be selected.

The tile is created around the symbol.

Parameters on top of the list displace the ones that are below.

The operator can freely place the tiles.

The settings must be confirmed.

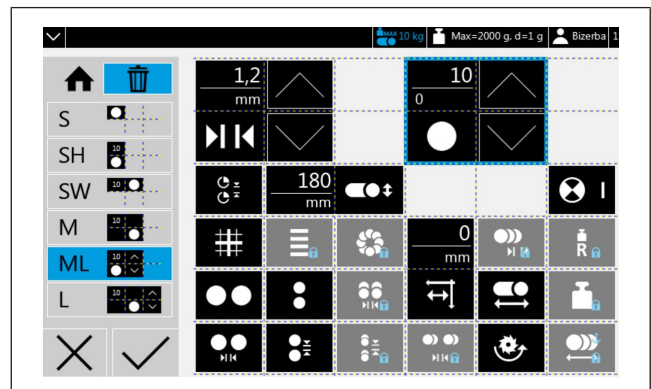

Fig. 33: Tile manager

6.6 Image manager

(not available for all variants)

Images on the current slicing program can be shown in the information bar on the touchscreen.

Up to two images per PLU may be loaded and saved, e.g. an image of the product and an image of the result.

If two images were saved the display changes every 5 seconds or can be changed by the touch of a finger.

Loading and saving images:

⇒ To open PLU menu tap the arrow on the information bar.

or

⇒ Wipe in arrow direction.

⇒ Tap 

The input mask opens.

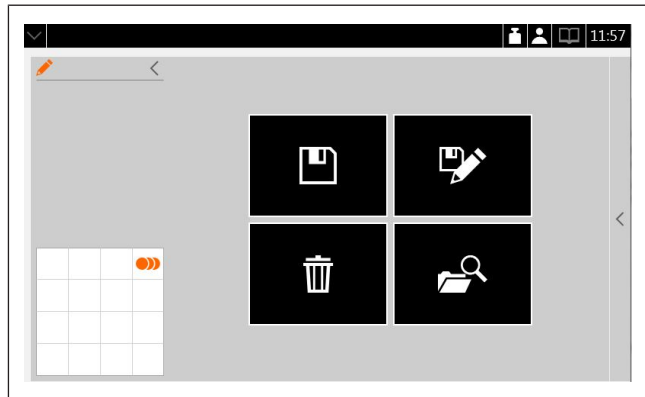

Fig. 34: PLU menu

- USB stick is plugged in the display and operating unit.
- File format: jpg or png
- File size: max. 100 kb per image
- Image format 4: 3

⇒ Tap in the image field.

A list of the images on the USB stick is shown.

⇒ Select an image and confirm.

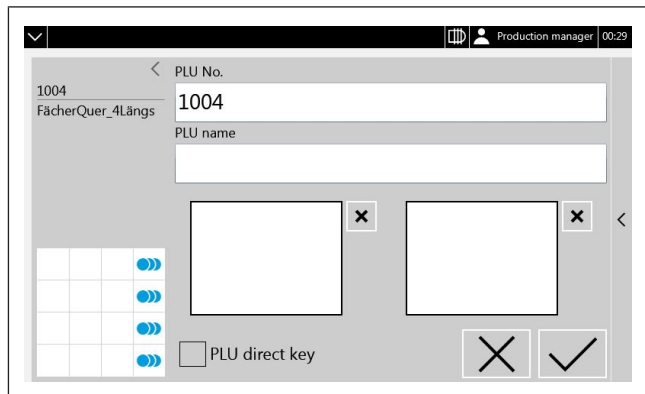

Fig. 35: Input mask

Loading a new image deletes the old one.

The image can be deleted with the <x> next to the image. In doing so it is also deleted from the database for this PLU.

6.7 Search mask

(not available for all variants)

All PLUs stored can be searched if you want to call up a particular PLU.

Using the filters of the search mask the number of the selectable PLUs displayed can be limited.

⇒ To open PLU menu tap the arrow on the information bar.

or

⇒ Wipe in arrow direction.

⇒ Tap 

The search mask opens.

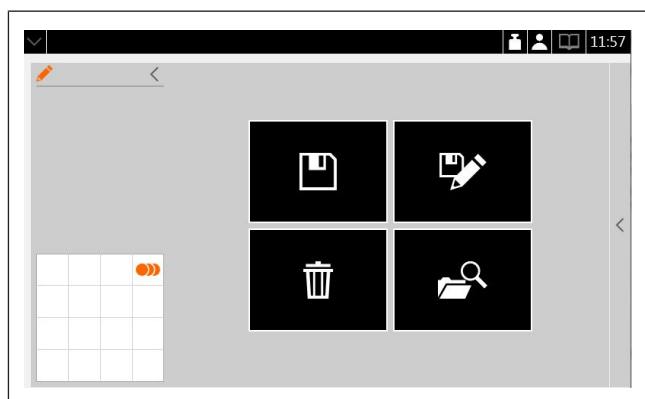

Fig. 36: PLU management

Saved PLUs can be filtered according to:

1. PLU No.
2. PLU name
3. Product width
4. Product height
5. Depositing type
6. Target weight

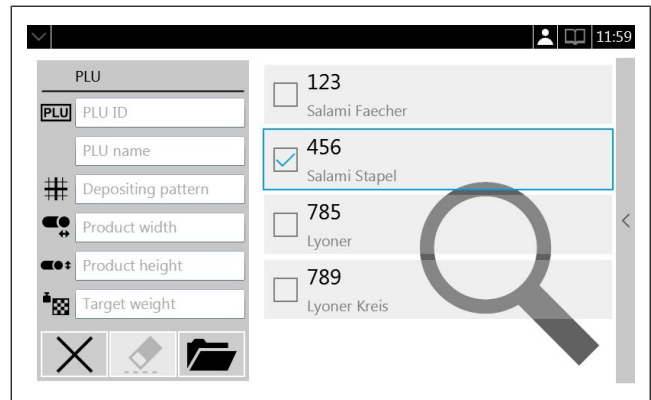



Fig. 37: Search mask

- ⇒ By tapping the corresponding text field the suitable input keyboard opens at the lower screen edge.
- ⇒ Enter search term or filter characteristic.
- ⇒ By tapping the down arrow or Enter the window with the keyboard closes.

The result is shown in form of a selection list.

Entries can be made in other fields.

Pressing the  icon all fields of the search mask are cleared (emptied) and all PLUs are displayed.

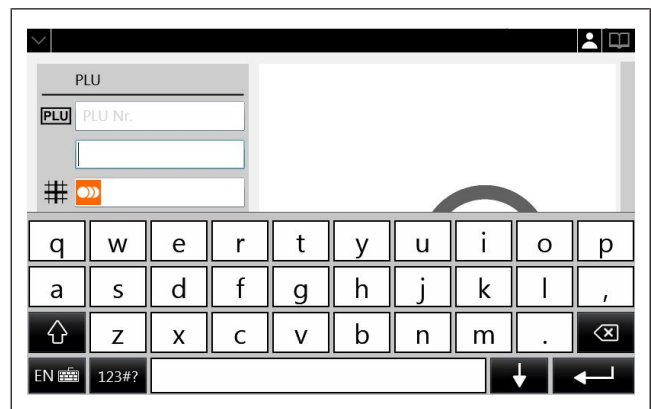



Fig. 38: Input keyboard

- ⇒ Tap in the selection list.
- ⇒ Tap <Open> 

The selected PLU is loaded.

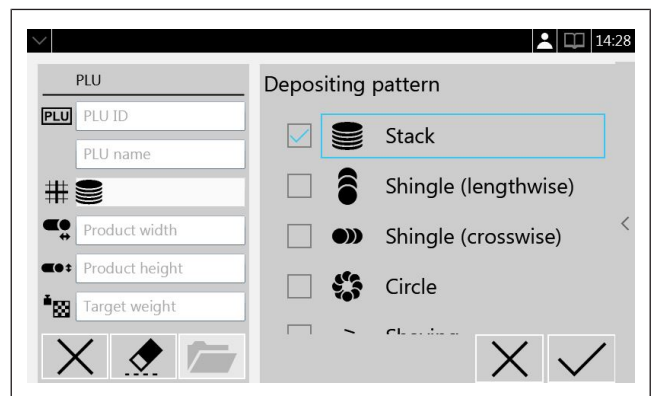



Fig. 39: Select PLU

6.8 Settings

(not available for all variants)

The page for settings can be called up from the navigation bar via .

Here, various settings may be performed with relevant authorization.

Settings concerning machine, software, operator and messages can be displayed and edited.

- ⇒ Tap a tile.
- The relevant menu appears on the touch screen.

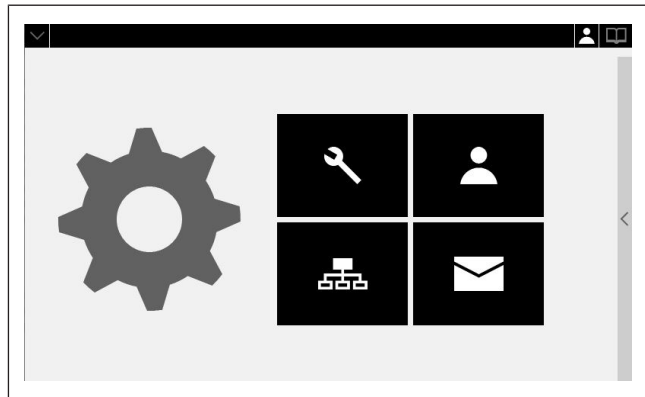

Fig. 40: Settings

6.8.1 User management

(not available for all variants)

Call up via the setting in the navigation bar.

- ⇒ Tap .

The user management menu opens.

Every user can change his password with the login. No password needs to be set until the production manager level.

Passwords of all lower levels can be set back to default by technicians or higher. This can be done for individual users.

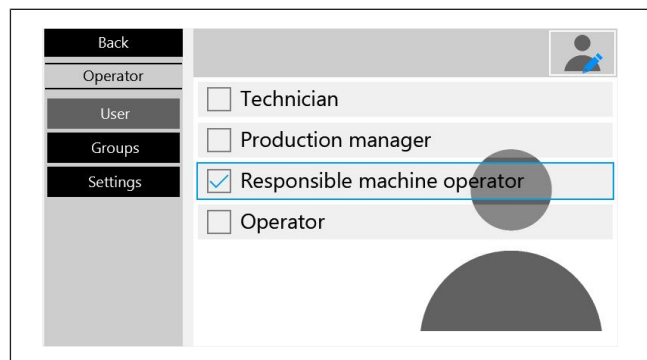

Fig. 41: User

Main page management

The authorization to individually configure the operator page can be disabled or enabled by the Technician for each authorization level:

- Technician is logged on.
- ⇒ Select authorization level.
- ⇒ Press the user icon with the pen.
- ⇒ Tick or remove the tick from checkbox "Home screen locked".
- ⇒ Save.

Display notes

In the same way the technician sets whether the notes "PLU changed" and "Portion complete" shall be displayed or not.

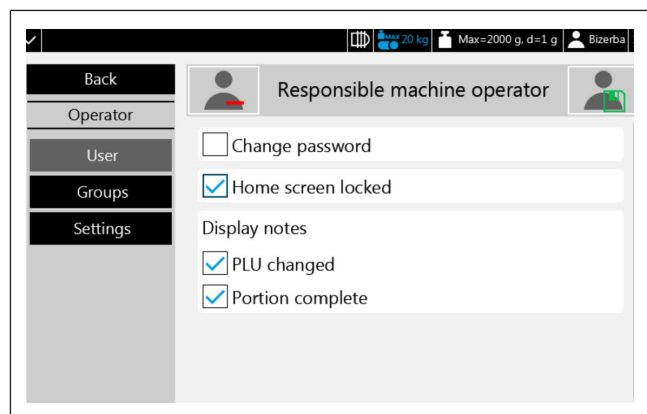

Fig. 42: Operator

User groups

⇒ Tap <Groups>

Here, user groups can be created.

For each group one user is created as default value. Name corresponds to the level name.

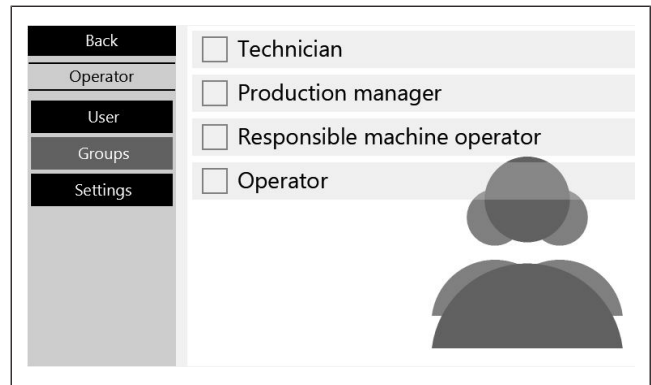

Fig. 43: Groups

Login settings

⇒ Tap <Settings>

Checkmark: Login in case of restart Login with a password is required.

No checkmark: The <Automatic login> can be done without a password. The machine is started with level Production manager.

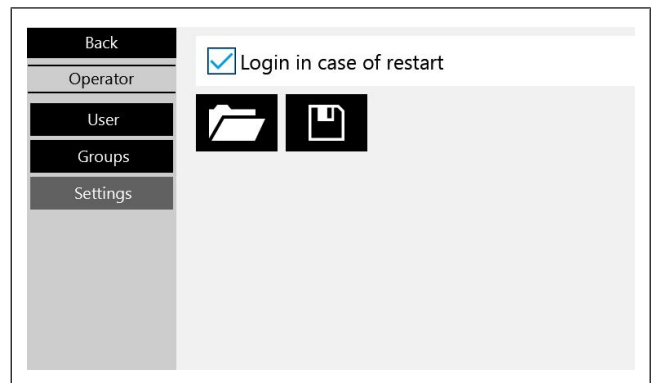
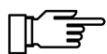

Fig. 44: Settings

Authorization levels:

Level	User rights
Operator	<ul style="list-style-type: none"> – Open PLU – Change language – Cleaning – Sharpening – Individual configuration of the operator page – Light sensor ON/OFF
Responsible machine operator	<ul style="list-style-type: none"> – All rights of level Operator – Change parameter temporarily
Production manager	<ul style="list-style-type: none"> – All rights of level Responsible machine operator – Save PLU
Technician	<ul style="list-style-type: none"> – All rights of level Production manager – Software settings – E-mail server – User management



The basic settings for the authorization levels can be changed by trained service personnel only.

6.8.2 Software settings

(not available for all variants)

Call up via the setting  in the navigation bar.

The VSI will be integrated in the network as a Client and communicates via nonsecure connections. The secure connection to the Internet must be ensured by the customer's network.

⇒ Tap .

Here, software settings may be performed with relevant authorization.

⇒ Press <Network>.

- DHCP is switched off.

⇒ Enter "IP", "Subnet", "Gateway" in format xxx.xxx.xxx.xxx.

⇒ Adopt changes to the settings by saving.

If DHCP is activated (checked), the settings cannot be changed.

Date / time

In order to use various functions it is important to enter the correct date, time and time zone at the place of installation of the machine.

⇒ Press <Date / time>.

⇒ Make and save settings.

User Interface colors

⇒ Press <Color spectrum>.

User interface colors may be changed.

If 2 equal colors are chosen, the modification is denied via error message. Distance of vector must be at least 50.

⇒ Confirm color changes.

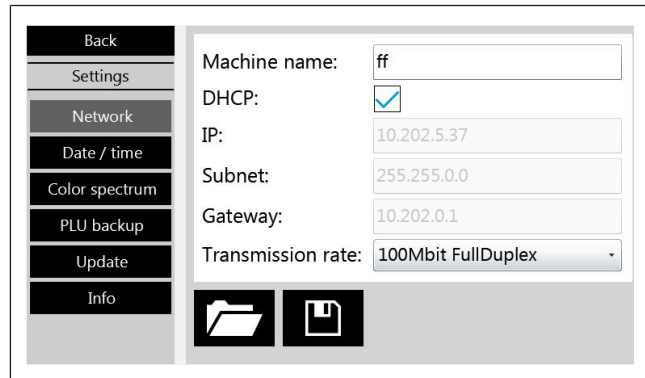

Fig. 45: Network settings

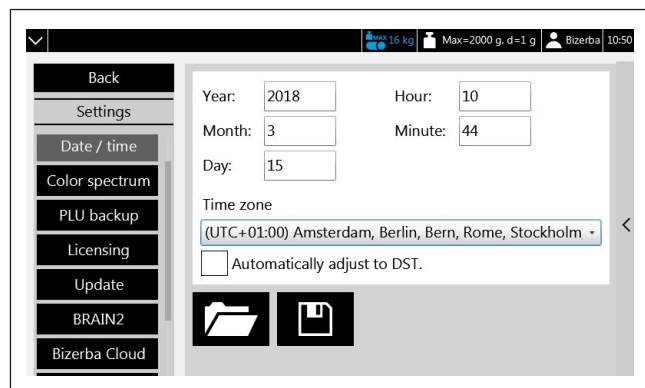

Fig. 46: Date / time

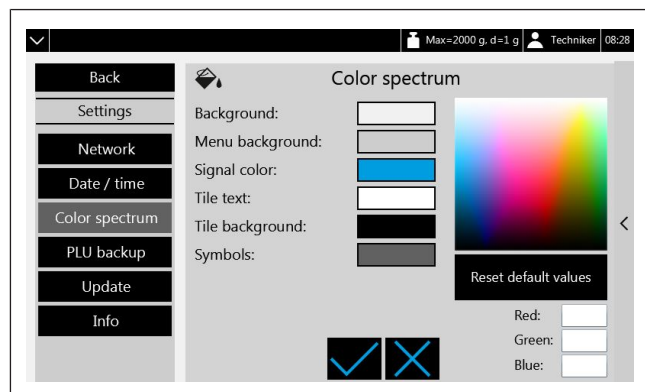

Fig. 47: User Interface colors

6.8.3 PLU data backup

(not available for all variants)

Call up via the setting  in the navigation bar.

⇒ Tap .

Creating a backup:

- ⇒ Press <PLU backup>.
- ⇒ Select storage space (flash memory, USB, SD card, network drive).
- ⇒ File name assigned. Alphanumeric characters (upper case, lower case, no um-lauts), hyphen, underscore and space are permitted.
- ⇒ Confirm.

The system attaches the current date and time to the entered file name.

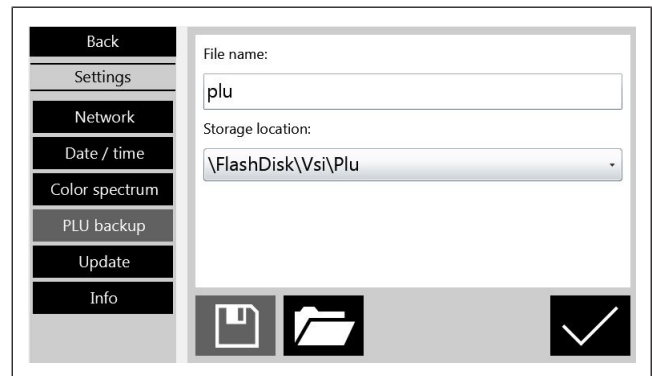



Fig. 48: PLU backup

PLU import:

- ⇒ Press .
 - Found files are displayed in a selection list.
 - ⇒ Select file.
 - ⇒ Confirm.
- File will be imported.

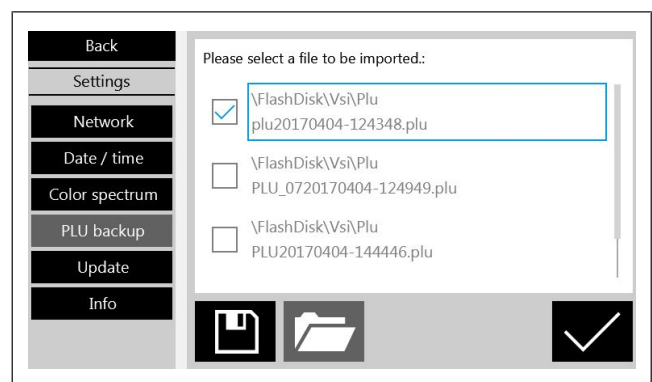

Fig. 49: PLU import

Storage options:

- Internal flash memory of CPU module
 - Connected USB storage
 - Optional SD card
 - Network drive (path, user, password)
- Access data can be saved in the machine if needed.

6.8.4 Licensing of additional functions

(not available for all variants)

To be able to use additional functions of the machine you must purchase licenses. The input of the license code to activate extra functions is described in the following.

Call up via the setting  in the navigation bar.

- ⇒ Tap .
- ⇒ Press <Licensing>.
- ⇒ Enter and save license code.

The functions for which the licenses were acquired are activated.

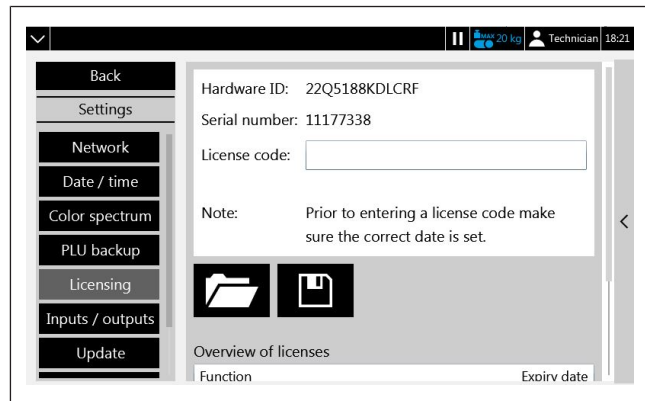

Fig. 50: Licensing

- ⇒ Scroll downwards.
- An overview of the acquired licenses with expiry date will be shown.

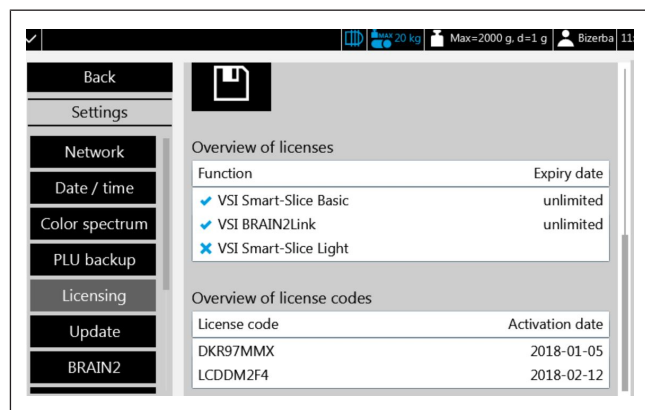

Fig. 51: Licensing

If the machine has no license, error message "No VSI Smart-Slice license availableSlicing requires an existing license." will be shown when starting the slicing process.

If the machine has a "VSI Smart-Slice Light" license, the "VSI Smart-Slice Basic" license can not be loaded.

If the machine has a "VSI Smart-Slice Basic" license, the "VSI Smart-Slice Light" license can not be loaded.

6.8.5 BRAIN2 function

(not available for all variants)

The connection of the VSI to BRAIN2 is an option by means of which data is exchanged for statistical evaluation between the machine and BRAIN2.

Requirement: License "VSI BRAIN2Link" is available. [► 55]

Call up via the setting  in the navigation bar.

- ⇒ Tap .
- ⇒ Press <BRAIN2>.
- ⇒ Tick checkbox "Use BRAIN2 function".

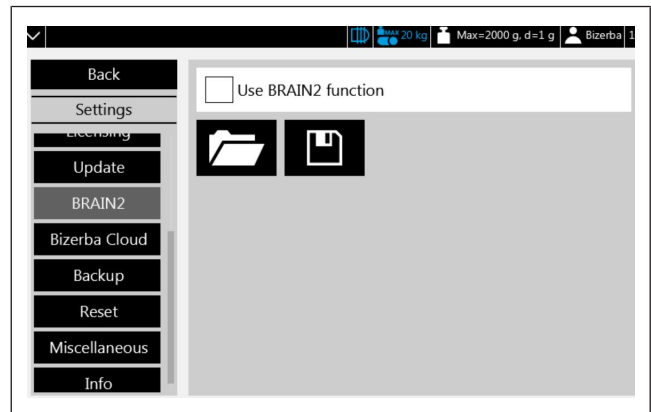

Fig. 52: Use BRAIN2 function

- ⇒ Perform configuration settings.
 - IP address server (UDP)
 - Port (standard: 10045)
 - Machine number
 - Sending spontaneous data
- ⇒ Save configuration settings.
- ⇒ Restart machine.

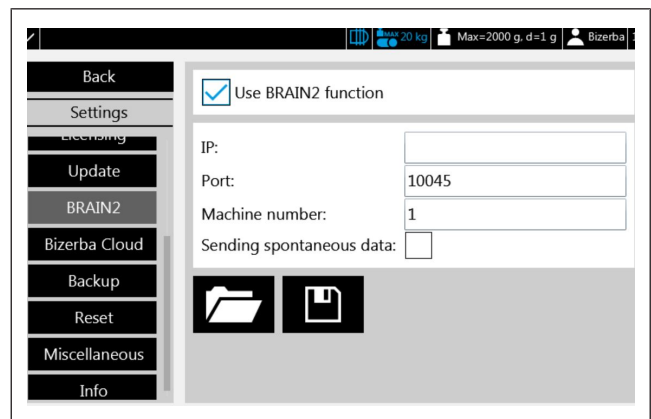

Fig. 53: Configuration settings

The machine sends the data to the set IP address.

Data exchange

Communication VSI to BRAIN2

"Complete portion sliced"

Will be sent after each completely sliced row (stack, shingles, circular pattern) when slicing to target weight.

Communication BRAIN2 to VSI

"Load PLU"

"Change number of portions"

"Switch on / off first cut"

6.8.6 Cloud function

(not available for all variants)

Call up via the setting  in the navigation bar.

- ⇒ Tap .
- ⇒ Press <Bizerba Cloud>.
- ⇒ Tick checkbox "Use Cloud function"

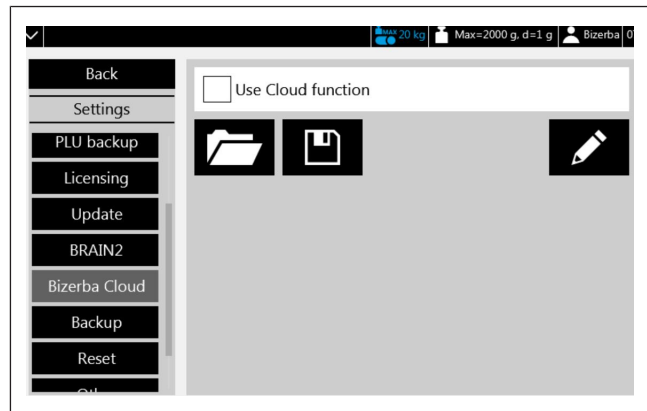

Fig. 54: Use Cloud function

- ⇒ Perform configuration settings according to requirements of the cloud.
- ⇒ Save configuration settings.
- ⇒ Restart machine.

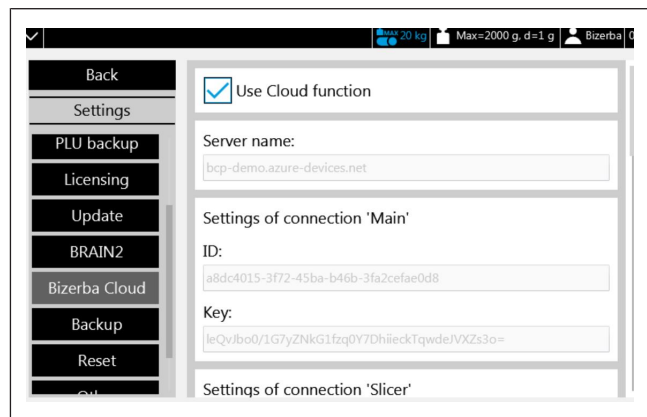

Fig. 55: Configuration settings

6.8.7 I/O interface

(not available for all variants)

The I/O interface allows communication between the slicer and other machines (such as tray dispenser, packaging machine). Information is exchanged using digital input and output signals.

Requirements:

- I/O hardware is installed
- I/O voltage = 24 V
- External power supply with 24 V
- M12, 8-pin connector on transfer point

1. Digital input 1
2. Digital input 2
3. External GND
4. External 24 V
5. Digital output 1
6. Digital output 2
7. External GND
8. External 24 V

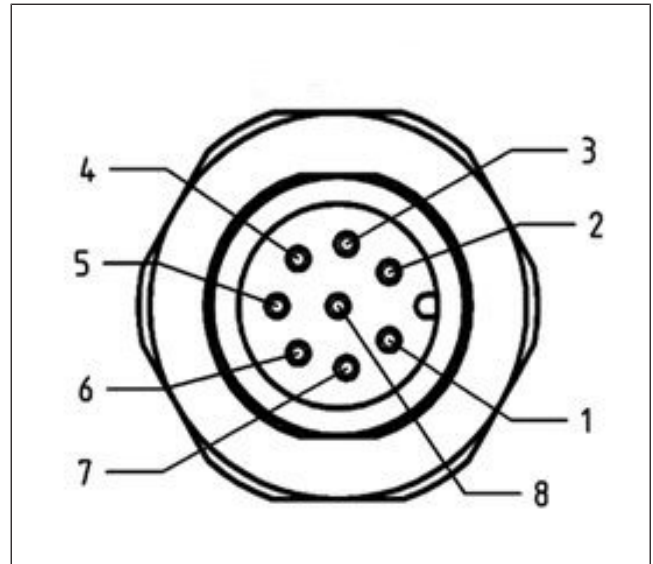

Fig. 56: Connector side

Configuring digital outputs and digital inputs

Call up via the setting  in the navigation bar.

⇒ Tap .

Here, software settings may be performed with relevant authorization.

⇒ Press <Inputs / outputs>.

Here you can configure digital outputs and digital inputs.

These settings are valid for all PLUs.

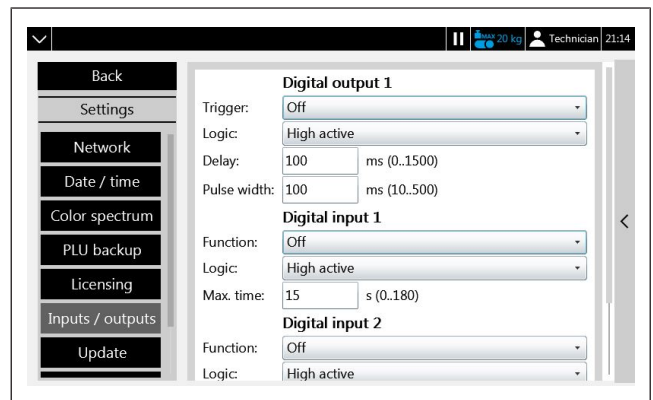

Fig. 57: Inputs / outputs

Output signal

The slicer sends signals to the connected machine via the I/O interface.

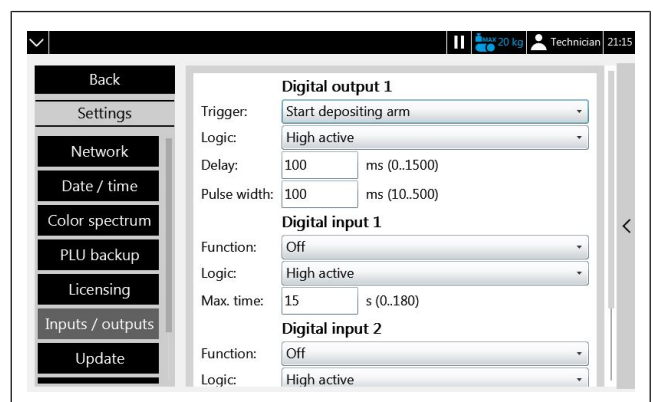

Fig. 58: Digital output

Digital output trigger	Signals
Off	Signal is not active.

Digital output trigger	Signals
Start depositing arm	Signal is sent as soon as the depositing arm starts moving.
Start depositing arm, last slice w/o signal	Signal is sent as soon as the depositing arm starts moving. After depositing the last slice of a row no signal is sent.
Status for slicing portions	Signal is active during slicing. Signal is not active during first cut program.
Dispense tray	

Input signals

Via the I/O interface the slicer receives signals that cause the carriage and/or conveyor belts to pause.

The slicer also receives the signals to return to operation via the I/O interface.

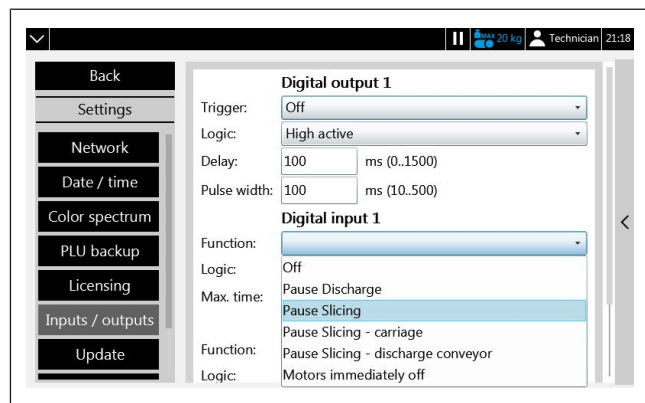

Fig. 59: Digital input

Digital inputs functions	Pause
Off	Signal is not active.
Pause Discharge	Pausing of conveyor belt. No discharge step. The current portion will be completely sliced. If Max. time is exceeded, machine switches from pause to stand-by mode. In this case, slicing must be restarted.
Pause Slicing	The conveyor movement is paused immediately and the carriage movement when the carriage is in no-motion condition. Current cut is being completed. If Max. time is exceeded, machine switches from pause to stand-by mode. In this case, slicing must be restarted.
Pause Slicing - carriage	Pausing the carriage movement as soon as the stand-by position is reached. Current cut is being completed. If Max. time is exceeded, machine switches from pause to stand-by mode. In this case, slicing must be restarted.
Pause Slicing - conveyor	Pausing the conveyor movement.

Digital inputs functions	Pause
Motors immediately off	<p>Signal stops all motors immediately. Button <Execute> goes off.</p> <p>Once the signal is deactivated, the <Execute> button starts flashing. Press <Execute> to start the reference run.</p> <p>In case of the VSI TW the last portion is automatically discharged towards the back during the reference run. Slicing is automatically restarted after the reference run.</p>

6.8.8 Further settings

Call up via the setting  in the navigation bar.

Software settings can be made with authorization level Technician.

⇒ Tap .

⇒ Press <Miscellaneous>.

Sharpening:

If the checkbox is ticked (default), the blade cleaning is carried out in 2 steps.

Step 1: The gauge plate opens by 3 mm to cut the cardboard in order to remove the grease from the blade.

Step 2: The gauge plate opens completely in order to mount the sharpener.

Gauge plate:

If the checkbox is ticked (default), the gauge plate closes automatically after a machine stop.

Standard PLU:

If the checkbox is ticked, the standard PLUs will be hidden. When delivered, the standard PLUs are active.

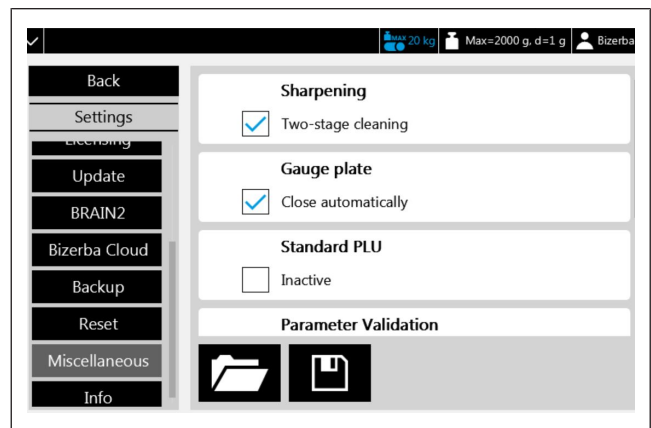

Fig. 60: Further settings

Parameter Validation:

If the checkbox is ticked (default), parameter changes must be confirmed by the operator.

Clear belt:

If the checkbox is ticked, after reaching the last portion (program or product end) the conveyor belt will be completely cleared.

The clearing of the belt can be stopped via <Execute>.

Standard: Clear belt inactive.

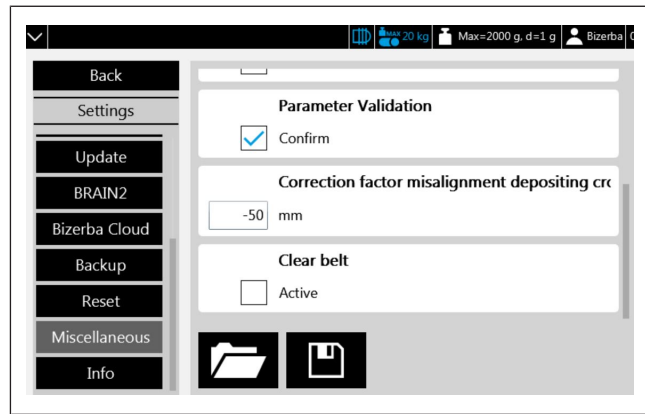



Fig. 61: Further settings

Correction factor misalignment depositing crosswise:

With this parameter, the offset which occurs during depositing can be corrected.

Example: When shingling crosswise the shingles are slightly inclined on the depositing area. The offset between first and last slice will be entered as a correction factor (between -50 and 50). When slicing again, the shingles will be deposited straight.

6.9 Load the product

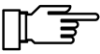
	<p>⚠ CAUTION</p>
	<p>There are spikes on the product holder! Driver hooks on feed carriage, grip hooks! Risk of injury.</p> <ul style="list-style-type: none"> – Use handle when working with product holder. – Claws are lowered into a rest position.
	<p>The machine must not be operated without a depositing table or conveyor belt.</p>
	<p>Any metal clips must be removed from the product. To safely slice leftover pieces the end of the sliced product has to be cut off.</p>
	<p>NOTICE</p>
	<p>If the product is lower than the height of the carriage rear wall, fingers could get jammed between product holder and carriage rear wall.</p>

Carriage with swivel-mounted product holder, horizontal product fixation

- The machine is switched on, all functional parts are in a stop position, carriage is on the side of the operator.

⇒ Take hold of product holder handle, loosen locking lever by using your index finger and lift up until snapped into place.

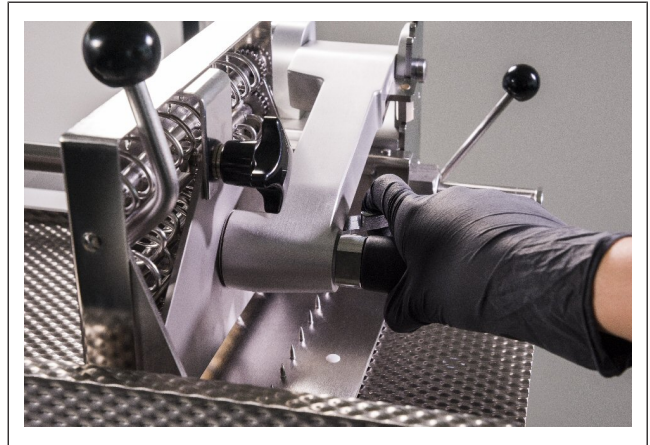

Fig. 62: 400 mm carriage

⇒ Place product against rear wall and press into hooks of feeding carriage.
⇒ Release the sliced product holder by means of the lock lever, place it on the sliced product and push down the spikes.

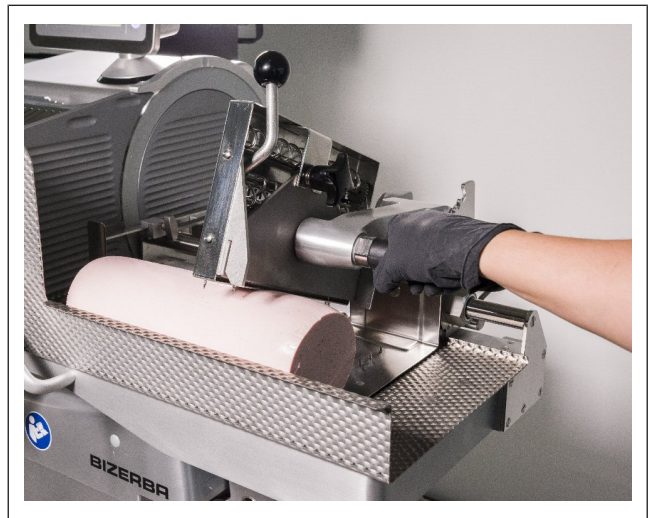

Fig. 63: Load the product

⇒ Pull the lever towards the operator while at the same time pushing the guide manually up to the gauge plate.
⇒ Position product fixation device.



Fig. 64: Unlocking product feed

Carriage with product holder which cannot be swiveled, vertical product clamping

- The machine is switched on, all functional parts are in a stop position, carriage is on the side of the operator.

- ➔ Using the left hand, position product against rear wall and push against holder.
- ➔ Using your right hand, push lever of holder downwards allowing prongs to enter the product ends thereby holding the product (if needed, make end piece bigger by cutting it).
- ➔ Push product towards gauge plate.
- ➔ Position product fixation device.

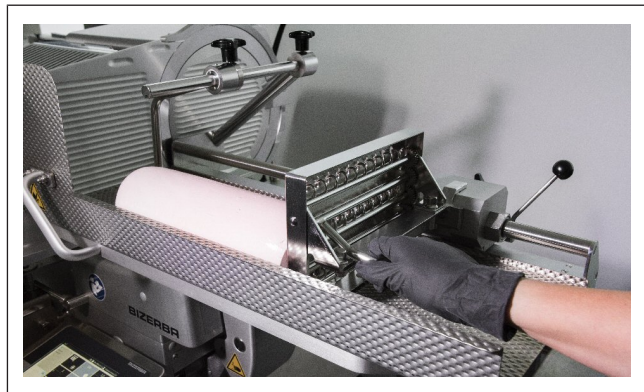

Fig. 65: 600 mm carriage

6.10 First cut function

(not available for all variants)

The First cut function serves to cut the first slices of a fed product and to keep them separate from subsequent regular portions.

The first cut is done during portion start and after product change.

Slices will be put down separately in a pile and not be counted as portion. Slice thickness is the size currently set for slicing portions.

- ➔ Tap tile First cut

A window appears where you can enable / disable the function and change the number of first cut slices.

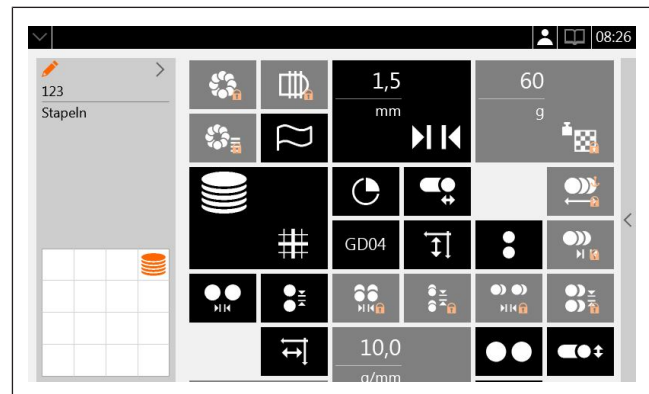

Fig. 66: Select tile First cut

- ➔ Tap First cut icon on the right.
First cut function is enabled. First cut icon is displayed in status bar. If this function is disabled, the tile First cut is grayed out.
- ➔ Enter number of First cut slices directly or change the value step by step using the Up/Down keys and confirm.

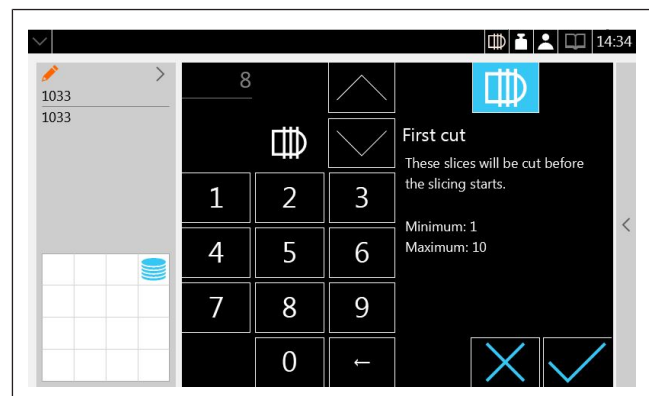

Fig. 67: First cut parameters

The first cut icon flashes in the status bar:

- before and during first cut slicing
- after resetting the portions counter to zero
- to show that the first cut is done after product change and again after restart.

Function First cut discharge 

This function is available for devices with conveyor belt.

It is always active when the function first cut is active.

The first cut slices are transported. It can be selected if the first cut is to be transported forwards or backwards.

6.11 Discharge function

The discharge of the sliced product on machines with a conveyor can be switched off. This allows to use the machine with conveyor same as a machine with depositing table.

- ⇒ Briefly tap tile Speed Discharge . A window opens to activate / deactivate this function and to change the speed.

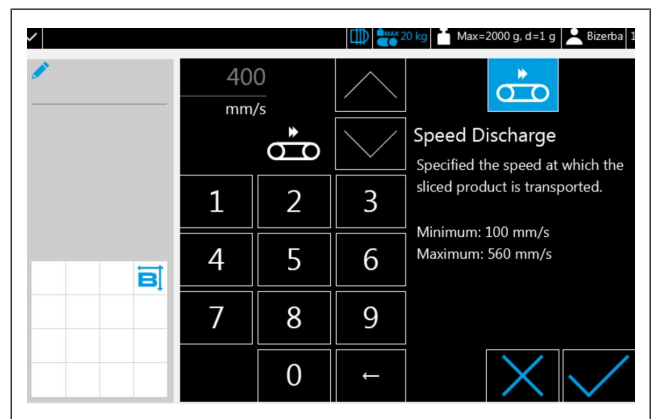

Fig. 68: Discharge switched on

- ⇒ Pressing icon <Speed Discharge> activates / deactivates the discharge. If this function is deactivated, the tile is grayed out on the operator page.

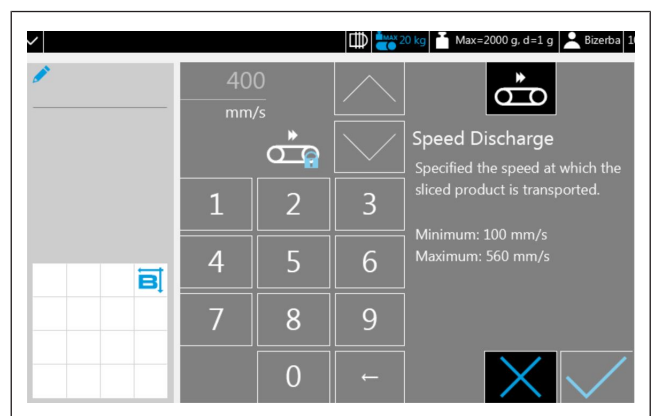



Fig. 69: Discharge switched off

The deactivation of the discharge only affects the slicing procedure. Despite this function deactivated a discharge step can be triggered by means of the following:

- Signal of the light sensor / light scanner
- Press <Execute> when the clear conveyor belt key  is active.

First cut

With the discharge deactivated, after slicing the first cut the machine with conveyor behaves in the same manner as the machine with depositing table. Notes: "Remove first cut slices from depositing table. Then start slicing procedure by pressing button <Execute>."

Incomplete Portion Discharge

Applies to machines with conveyor.

Discharge to the front

Weighing and conveyor belt are cleared towards the front.

Discharge to the back

VSI TW: Portion is located on the weighing belt. The weighing belt is cleared towards the back. The conveyor belt is cleared towards the front.

VSI TW: Portion is longer than the weighing belt. Discharge to the back not possible.

VSI T: One portion is located on the conveyor belt. The discharge is done towards the back.

VSI T: Several portions are on the conveyor belt. Discharge to the back not possible.

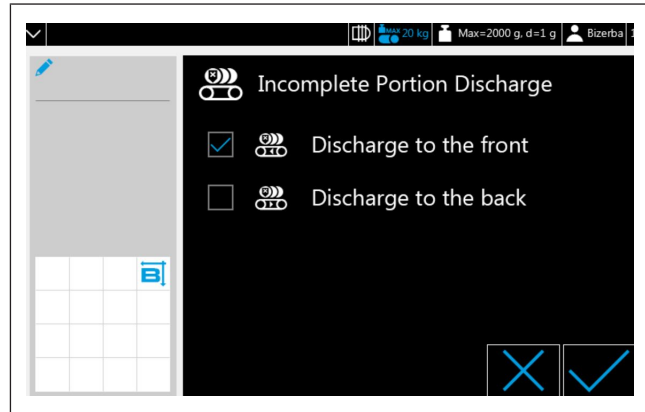





Fig. 70: Incomplete Portion Discharge

6.12 Slice product

	<p>⚠ DANGER</p>
	<p>Tipping hazard in case of overload! This may result in serious injuries and damage to property.</p> <ul style="list-style-type: none"> – Operate machine on stand only if its weight rests on the feet and the casters are locked. – Pay attention to max. load of machine when loading products. [▶ 110] – The machine must only be operated with the product securely fastened in the carriage. – The product weight shown in the status bar must not be exceeded.

	⚠ WARNING
	<p>Rotating blade! Cut injuries</p> <ul style="list-style-type: none"> – Do not allow yourself to become distracted. Concentrate on the task in hand and avoid time pressure. – During operation, do not reach into the path of the carriage. – Never push product ends towards blade by hand.

	⚠ WARNING
	<p>Moving components! Risk of entanglement, shearing, crushing and being hit.</p> <ul style="list-style-type: none"> – Do not wear loose clothing or wear hair down. – Do not reach into paths of carriage, product holder, gauge plate, depositing system, conveyor and depositing table. – Only clean machine when switched off and power plug is pulled.



To ensure safe operation the machine can reduce the number of carriage strokes for wider products.

- Product is loaded and fastened by means of product holder and product fixation device.
- Machine is switched on. The slicing program used last is shown on the touch screen.

Choose depositing type.

⇒ On touch screen tap tile .

The selection window for the depositing type opens.

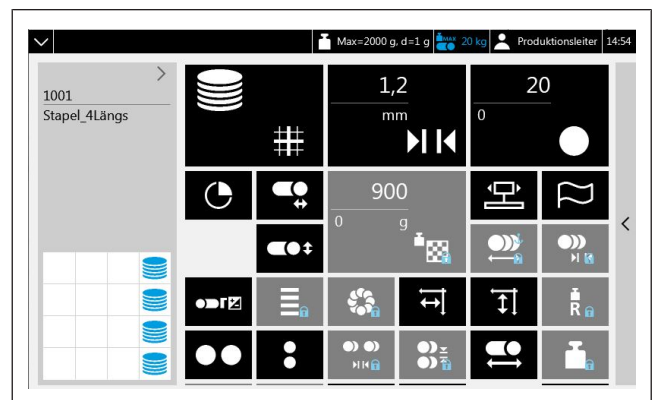

Fig. 71: Main page stacking

⇒ Choose depositing type. (stacks, shingles lengthwise, shingles crosswise, circular pattern, shaving)

The selection will be shown via a check.

⇒ Confirm selection.

The default values for the selected Deposit-
ing type will be loaded.

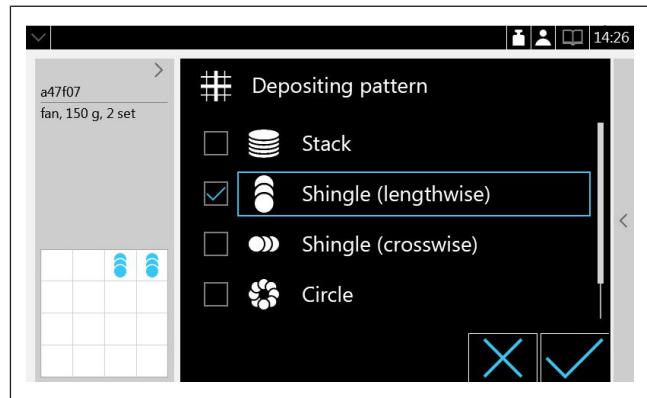

Fig. 72: Choose depositing type

Changing parameters.

⇒ Tap tile of parameter to be changed.

The window to change the parameter opens. The value of the parameter may be changed.

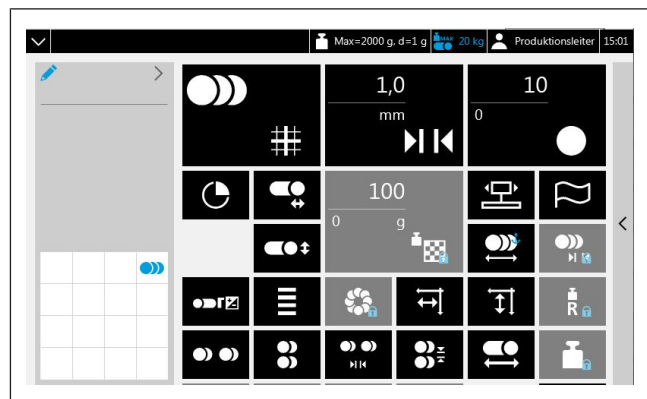

Fig. 73: Main page shingling crosswise

⇒ Enter value directly or change value step by step using the Up/Down keys and confirm.

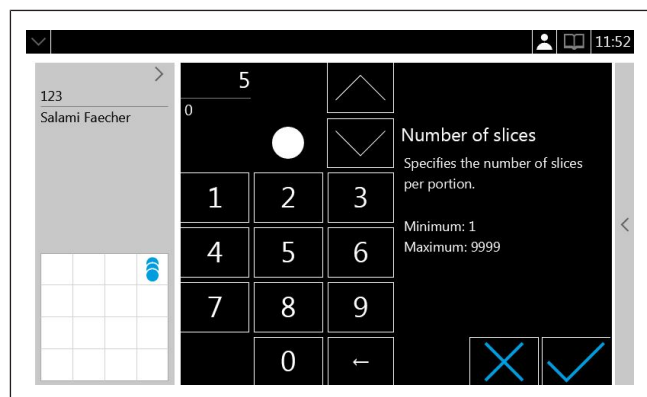

Fig. 74: Change parameters

Changing a parameter always results in a parameter validation.

In a dialog, the operator can except or discard the parameter change. The changes of validated parameters will be shown.

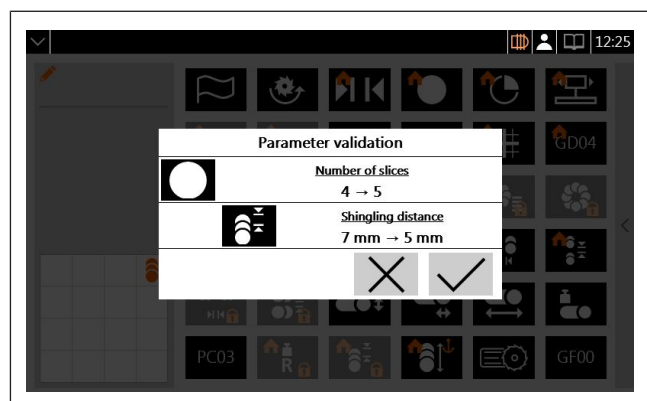

Fig. 75: Parameter validation

Saving changed parameters.

⇒ To open PLU menu tap the arrow on the information bar.

or

⇒ Use your finger and wipe in arrow direction.

⇒ Tap .

A mask to enter PLU number and PLU name opens.

⇒ Tap the write field.

The input keyboard is shown.

⇒ Enter and confirm PLU number and name.

A new PLU or an existing PLU under a new number was saved.

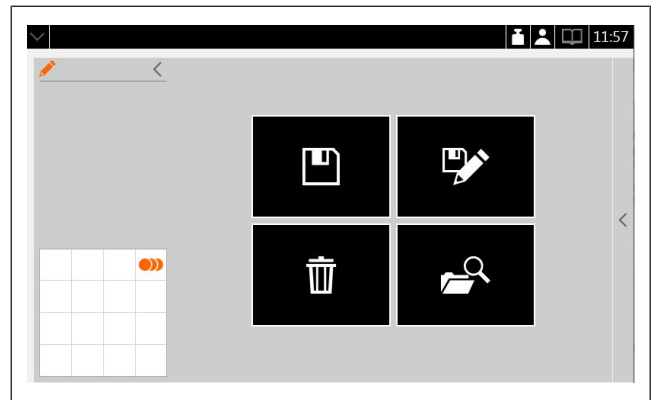

Fig. 76: PLU menu

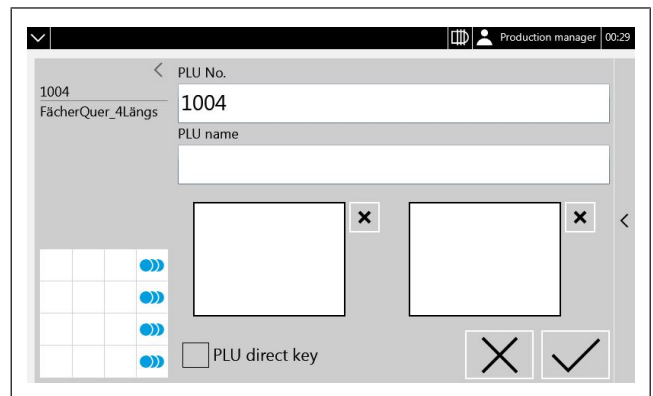

Fig. 77: Input mask

Opening a PLU.

⇒ To open PLU menu tap the arrow on the information bar.

or

⇒ Use your finger and wipe in arrow direction.

⇒ Tap .

⇒ Select desired PLU from the list and open it by tapping .

The PLU with the saved parameters will be displayed.

⇒ Tap <Execute> to start the slicing program.

The carriage starts moving and, based on the program, the product is sliced, weighed and placed on the depositing table or conveyor belt.

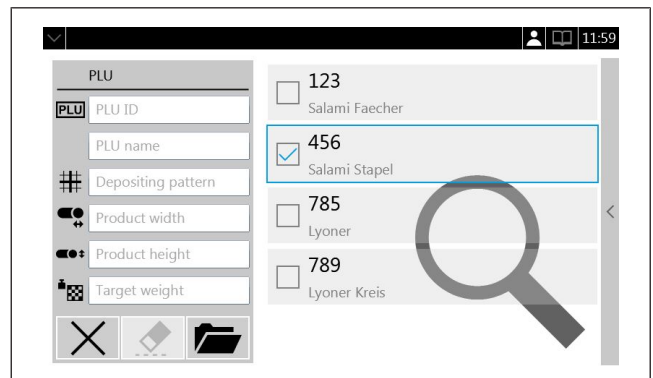

Fig. 78: Open PLU

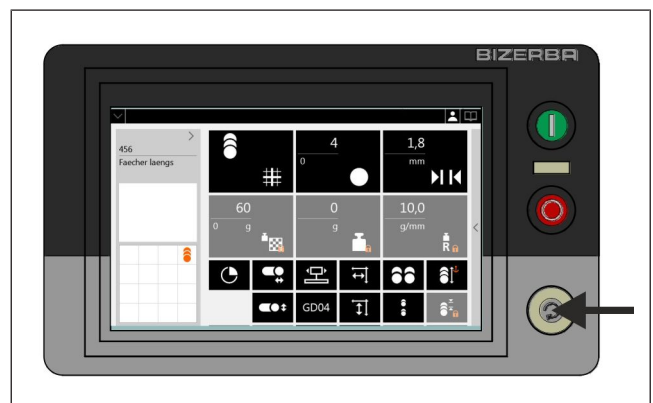

Fig. 79: Display and operating unit

6.12.1 PLU direct key

(not available for all variants)

Direct PLU keys on the main page allow fast opening of saved PLUs. Whether a PLU has a direct key can be selected in the PLU menu.

⇒ To open PLU menu tap the arrow on the information bar.

or

⇒ Wipe in arrow direction.

⇒ Tap 

The input mask opens.

⇒ Tick checkbox next to the PLU direct key.

⇒ Confirm.

A tile of the PLU will be created on the main page.

The new tile appears on the main page after the last current tile.

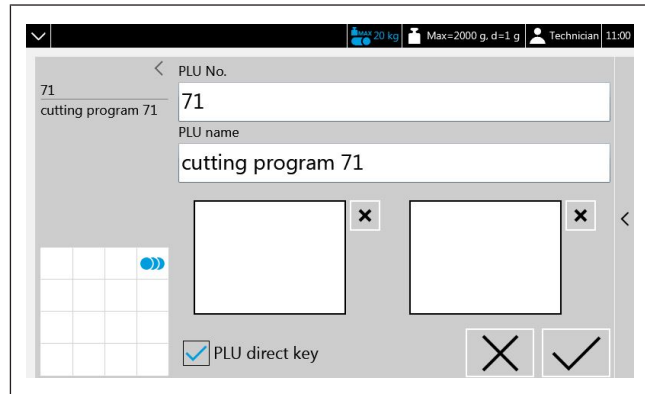

Fig. 80: PLU direct key

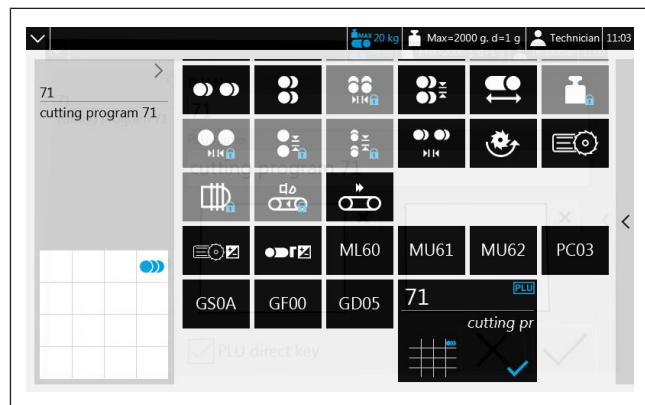

Fig. 81: PLU direct key

6.13 Slicing to target weight

(not available for all variants)

The slicer with integrated scale allows target weight slicing. Once the target weight is reached, the machine stops the slicing procedure.

The portion scale is not metrologically approved and cannot be used for legal for trade applications.

During start-up the portion scale is calibrated by the customer service at the place of installation. The unit to be displayed will be set.

The scale can be switched on and off independent of the slicer.

Switch scale function on/off

To switch the scale function on/off tap tile Target weight  on the parameter page.

If the slicer is not fitted with a scale, the tile target weight is not available.

- ⇒ Tap tile Target weight  .
The window to switch the scale off/on and to change the target weight opens.

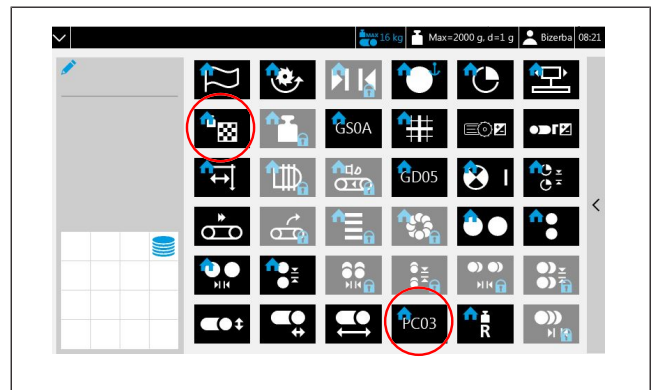

Fig. 82: Parameter page

Switch scale on/off.

- ⇒ Press the scale icon on the right.
Scale function is activated. The scale icon is displayed in the status bar. If this function is deactivated, the tile target weight is grayed out.
- ⇒ Enter target weight directly or change value step by step using the Up/Down keys and confirm.

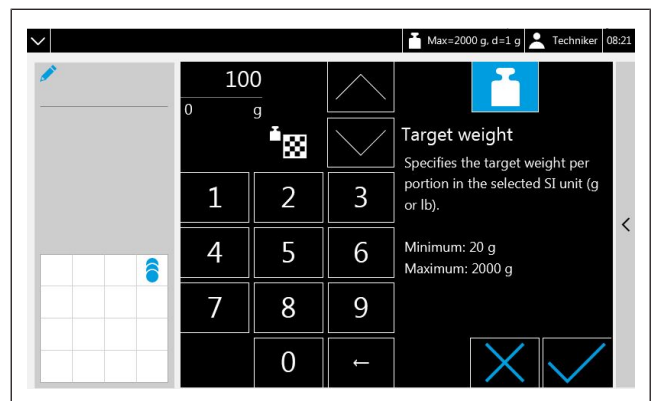

Fig. 83: Target weight parameter

Enter product profile.

- Parameter page.
- ⇒ Briefly tap tile <PC03>.
The window to enter the product profile opens.
- ⇒ Select whether this is a calibrated, slightly uncalibrated or heavily uncalibrated product.
- ⇒ Confirm.

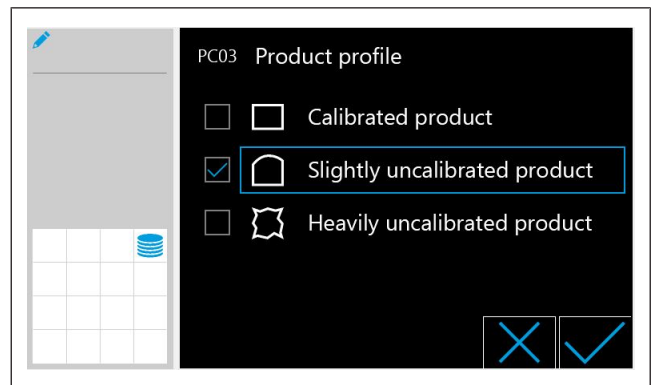

Fig. 84: Product profile parameter

Switching on the scale the following parameters are set:

- reference weight set to 8 g/mm
- anchor set to number of slices
- set target weight to the value that results from the current parameters

For machines with conveyor belt:



The shingling length currently set is longer than the weighing conveyor.

- Reduce shingling distance.

If it is not possible to reduce the shingling distance, a message is displayed.

Scale remains switched off.

Switching off the scale:

- The anchor set to number of slices or slice thickness will be deleted.

6.13.1 Reference weight

To enter or calculate the reference weight use the tile reference weight **R** on the parameter page.

- ⇒ Enter known reference weight directly or change value step by step using the Up/Down keys and confirm.

or

- ⇒ Press the calculator icon.
A guided entry to enter further parameter for the calculation of the reference weight is displayed.

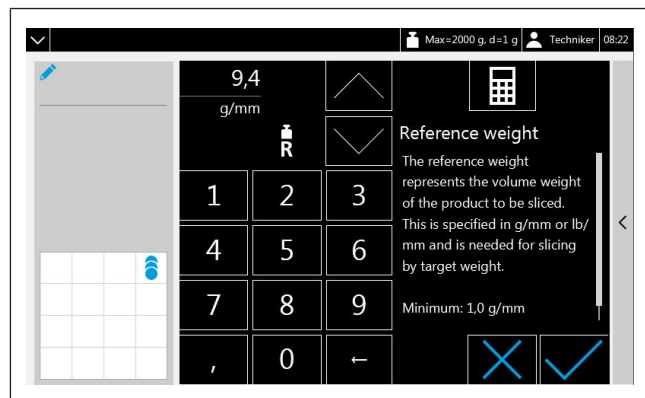

Fig. 85: Reference weight parameter

6.13.2 Conditions for weighing

The weight of each slice or row is determined during the slicing process and can be corrected accordingly by changing the slice thickness or the number of slices.

If the following requirements are met, the target weight is optimally reached. Deviations from the requirements can lead to target weight deviations.

Place of installation / environment

Installation surface must be level, shock-proof, vibration-free and free of air draughts.

Vibrations can affect measurements made by the scale. During production, avoid any vibrations (e.g. fork-lift truck activities) near the machine.

Installation

The machine has to be leveled exactly on the Bizerba stand.

To ensure the scale's accuracy, it is absolutely necessary that the machine is aligned horizontally.

NOTICE! At an inclination of > 1 degree of the scale as compared to the horizontal plane the established weight value is less than the actual weight.

Target weight	<p>Optimum as of 150 g.</p> <p>With a target weight smaller than 150 g the target weight deviation increases, even instable weight values are possible.</p>
Number of slices	<p>Optimum as of 4 slices per row.</p> <p>With fewer slices the target weight deviation increases, even instable weight values are possible.</p>
Product profile	<p>The more odd-shaped a product is (e.g. cheese holes) the more it is vital to slice at least 4 slices per row in order to increase the probability to reach target weight.</p>
Sliced product quality	<p>An unstable product will cause residues that will get mixed in further rows or lost during the transport. Reliable results cannot be guaranteed.</p>
Slicing performance	<p>The target weight deviation depends mainly on the size of the sliced product and the slicing speed.</p> <p>During machine setup check which parameter set is best to reach the target weight.</p>
Depositing area	<p>In any case the depositing position has to be within the depositing area to avoid force bypasses.</p> <p>Dirt may cause force bypasses and must be removed.</p> <p>Damaged or twisted wire meshing of conveyors causes functional errors.</p>

6.14 Ending slicing



To stop the slicing process, press <Execute>. Use the <OFF switch> only in an emergency to stop the slicing process.

	<p>⚠ WARNING</p>
<p>Gauge plate!</p> <p>Risk of crushing when gauge plate moves to zero position.</p> <ul style="list-style-type: none"> – Do not reach into area between gauge plate and carriage rear wall. – Do not reach into area between gauge plate, carriage and product holder. – Do not reach into area between gauge plate and blade. 	

⇒ On the display and operating unit press <Execute>.
The drives will be switched off.

The drives will be switched off automatically:

- if max. stacking height is reached
- at end of program

- at end of product
- in case of malfunctions, e.g. jam
- in case of voltage deviations outside the tolerance range >10 ms [► 111]
- if a safety circuit is interrupted

The drives go into stand-by position:

- if the conveyor belt stops because the light sensor detected "full belt"
- ⇒ Manually remove product.
Operations are continued.

7 Troubleshooting

7.1 Procedure

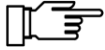

Should there be a stoppage and the problem cannot be corrected right away, food products have to be removed for protection in compliance with the maximum limit of 30 minutes for products to remain on the machine.

- ⇒ Switch off machine immediately if untypical noises are heard or if there is a suspected risk of injury.
- ⇒ Inform your respective Customer Services if you cannot remove the fault yourself.
- ⇒ Please provide the Bizerba customer service with the following information:
 - Machine type (see identification plate),
 - Machine number (see identification plate),
 - Error description.

This will make preparation of the customer service assignment much easier.

7.2 Fault description

If an interruption occurs during operation, this is displayed via an appropriate system message plus identification number.

- ⇒ Switch off machine.
- ⇒ Troubleshooting.
- ⇒ Switch machine on again after about 2 minutes and start again.
- ⇒ If the system message appears again, contact the relevant customer service and provide the displayed identification number [▶ 75].

Power failure

- ⇒ If there are power failures of >10 ms during operation the machine stops.
The display is switched off.
- ⇒ Switch on machine and start again.

8 Maintenance

8.1 Preparation for cleaning

Clean thoroughly:

- before putting into operation
- depending on use and application frequency
- depending on the product
- depending on the ambient temperature
- if extremely soiled, several times a day
- after sharpening
- after longer downtimes

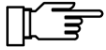

WARNING

Unprotected blade!

Coming in contact with the sharp blade can lead to serious injuries.

- Always wear cut-proof gloves when cleaning.
- Do not clean the surfaces of the blade when operating the machine!

- The machine is switched on.
- The main page comes up on the touch screen.
- All machine parts are mounted.

⇒ Press icon  on the navigation bar.
Instructions on the further operating procedure appear on the touch screen.

Unlock carriage:

- ⇒ Turn out star-grip screw on carriage foot.
- ⇒ Open holding magnet by pressing the <Execute> button.

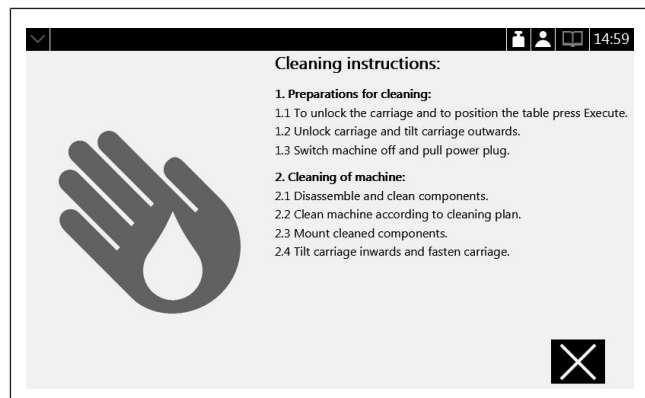



Fig. 86: Instructions on the further operating procedure

- ⇒ Tilt carriage outward into cleaning position within 10 s.
If time was exceeded, press <Execute> again.
- ⇒ Switch off machine.
- ⇒ Remove the plug and protect against moisture.



Fig. 87: Tilt the carriage to the outside

8.2 Removing components

	<p>⚠ WARNING</p>
	<p>Chain spikes, driver spikes of feeding carriage, gripper hooks, deflector edge!</p> <p>Stab and cut wounds.</p> <p>Twisted guide cam or chain spikes can cause malfunctions.</p> <ul style="list-style-type: none"> – Always wear cut-proof gloves when cleaning. – Avoid touching the chain spikes. – Claws are lowered into a rest position.

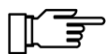

Do not place parts on top of each other to avoid mechanical damage.

Remove components as follows:

Depositing table VSI, VSI W

- ⇒ Use both hands to lift table up a little on the operator side and pull it to the front.



Fig. 88: Remove depositing table

Light sensor

- ⇒ Pull the light barrier upwards out of the holder and hang in to the holder of the machine.



Fig. 89: Remove light sensor

Conveyor VSI T

- ⇒ Tilt the lock on the belt support backwards in the direction of the arrow.

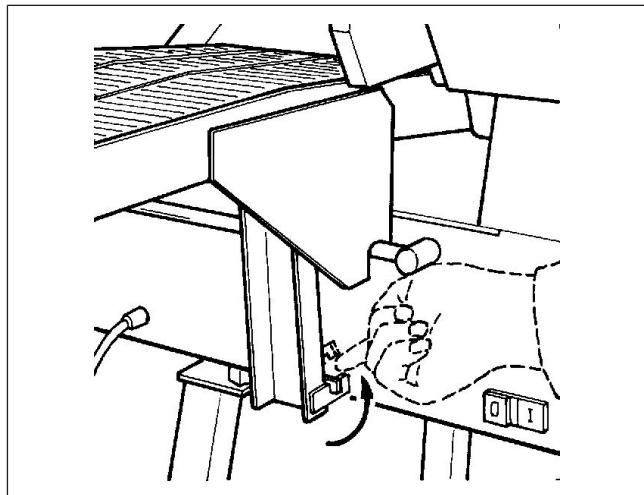

Fig. 90: Unlock conveyor belt VSI T

- ⇒ Pull conveyor belt on support bar towards operator.
Discharge conveyor has been decoupled from drive.

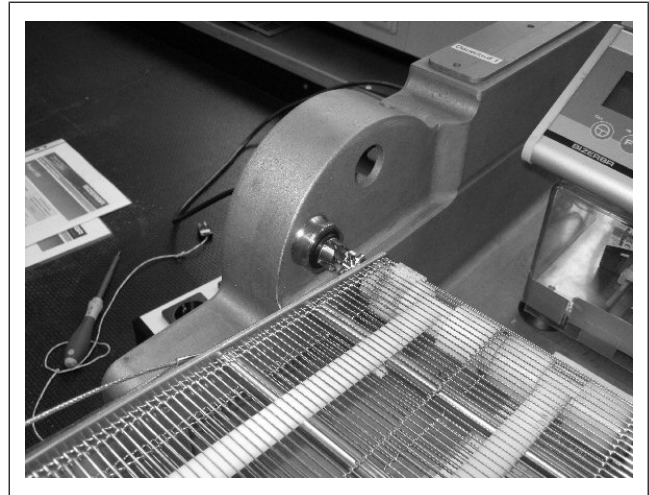

Fig. 91: Decouple conveyor belt VSI T

- ⇒ Use both hands to hold on to the sides of the center of the conveyor and tilt it towards you and then lift it up.
- ⇒ Carefully place discharge conveyor on an even surface.

NOTICE! Damaged or twisted wire meshing causes functional errors.

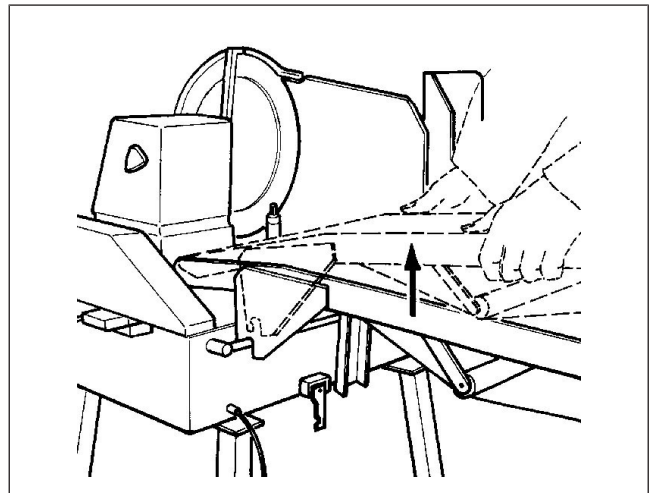

Fig. 92: Remove conveyor VSI T

Discharge conveyor VSI TW

- ⇒ Push lock at belt support upwards.

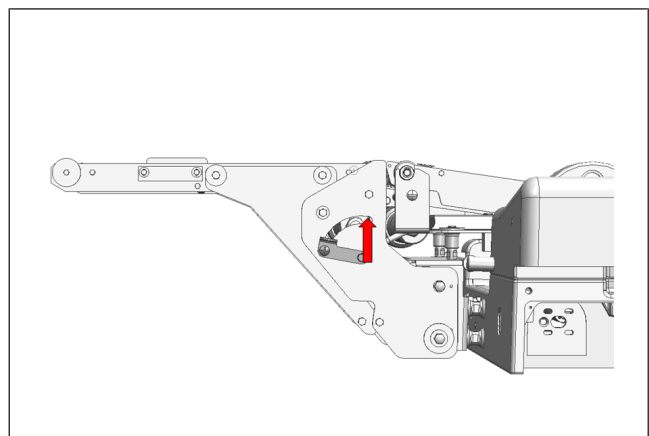

Fig. 93: Unlock discharge conveyor VSI TW

- ⇒ Remove discharge conveyor from the coupling to the right.
Discharge conveyor has been decoupled from drive.

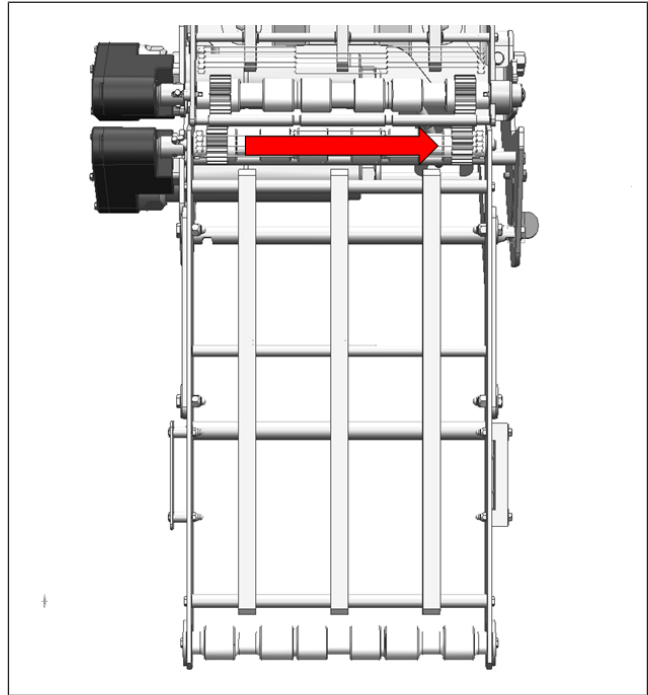

Fig. 94: Decouple discharge conveyor VSI TW

- ⇒ Remove discharge conveyor exactly towards the top.
- ⇒ Carefully place discharge conveyor on an even surface.

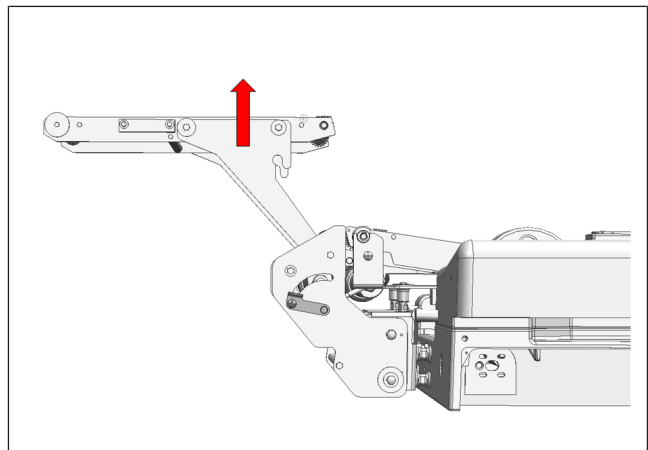

Fig. 95: Remove discharge conveyor VST TW

Weighing conveyor VSI TW

- ⇒ Lift weighing conveyor on the back, lift up right shaft end from the guidance.
- ⇒ Remove weighing conveyor from the coupling to the right.

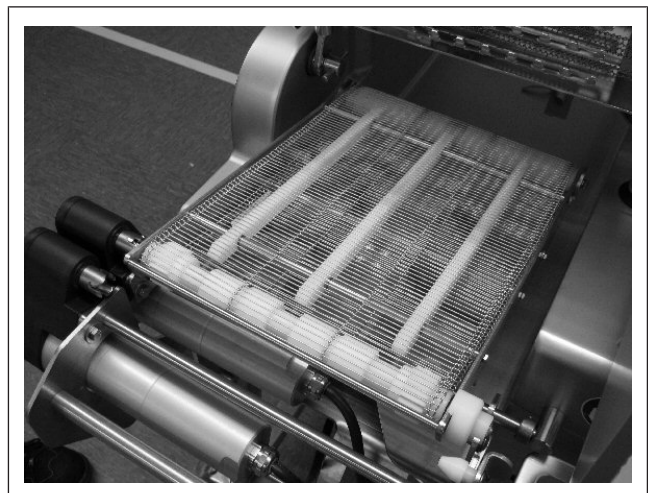

Fig. 96: Weighing conveyor

Depositing arm

- ⇒ Loosen screw connection and remove hub of depositing arm from bearing to the right.



Fig. 97: Depositing arm

Chain frame

CAUTION! Risk of injury at chain spikes.

- ⇒ Using the right hand, swivel feed roller to the left and hold it firmly.
- ⇒ Using the left hand lift the complete chain frame out of the bearing in the upward direction.
- ⇒ Put chain frame aside with rear side downward.



Fig. 98: Chain frame

Guide cam

- ⇒ Loosen clamp handle on frame and remove guide cam from between the conveyor chains.

NOTICE! Twisted guide cam or chain spikes can cause malfunctions.

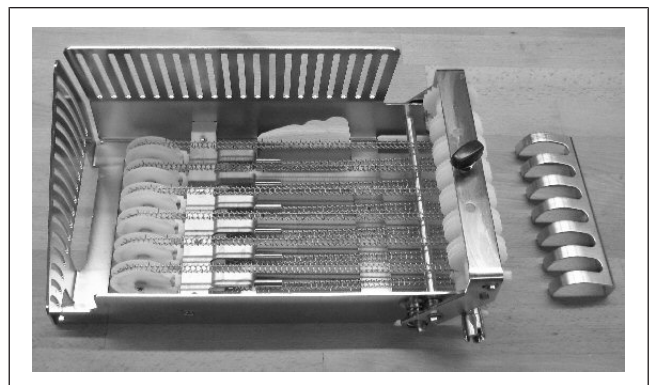

Fig. 99: Guide cam

Product holder, 400 mm carriage

- ⇒ Loosen star knob.
- ⇒ Remove product holder in upward direction.



Fig. 100: Product holder

Feeding carriage, 400 mm carriage

CAUTION! Risk of injury at driver spikes.

- ⇒ Take hold of product holder handle, loosen locking lever and swivel upwards until snapped into place.
- ⇒ Loosen star grip screw on the product holder guide and remove product support plate.

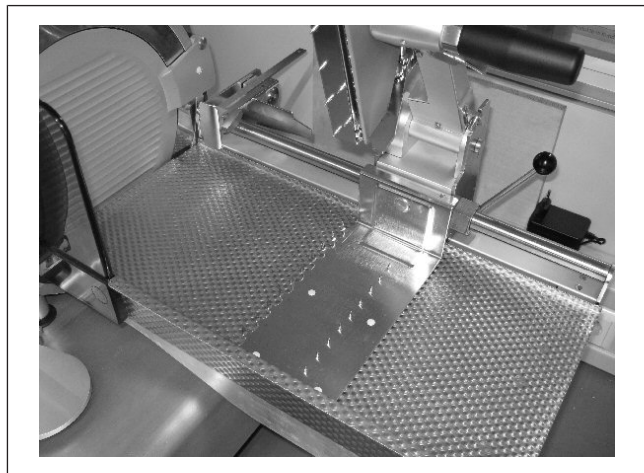

Fig. 101: Feeding carriage

Product holder

- ⇒ Loosen the star-grip handle on the product holder guide.
- ⇒ Remove product holder in upward direction.

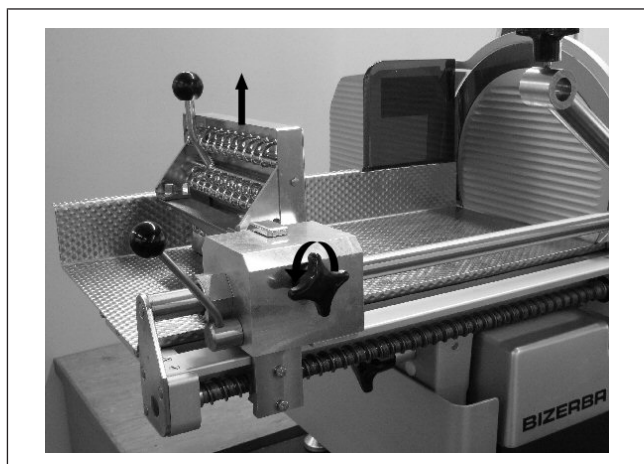

Fig. 102: Product holder

Product fixation device, vertical

- ⇒ Loosen star knob on guide element.
- ⇒ Remove product fixation device.

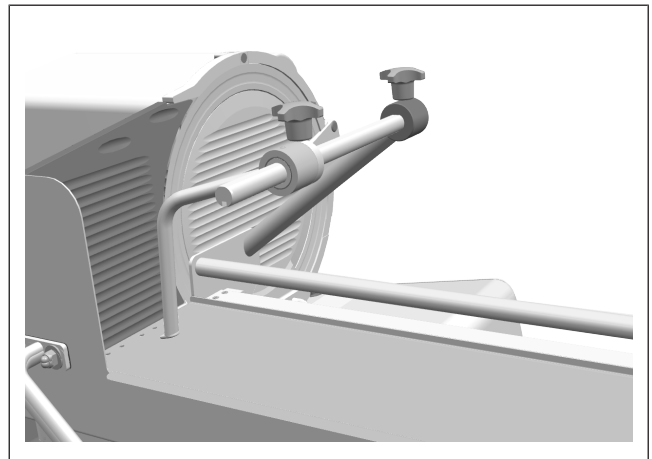

Fig. 103: Product fixation device, vertical

Product fixation device, horizontal

CAUTION! Do not reach into path of product fixation device.

- ⇒ Swivel product fixation device up by pressing the lever.

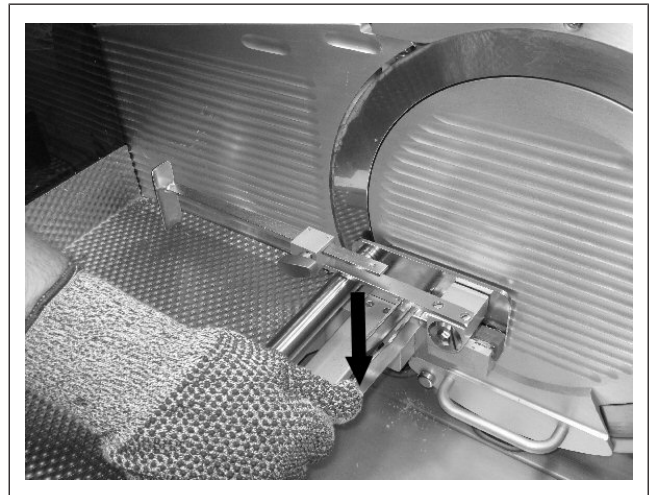

Fig. 104: Product fixation device, horizontal

- ⇒ Release clamp handle on guidance.
- ⇒ Remove fixation plate out of guidance upwards.

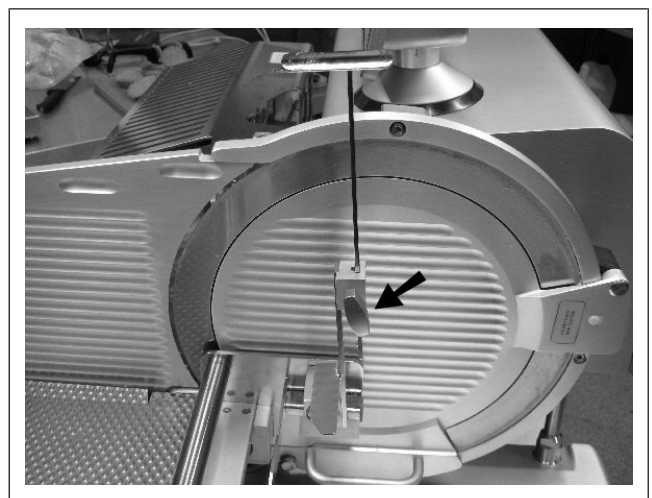

Fig. 105: Product fixation device, horizontal

Blade cover

- ⇒ Hold blade cover at handle.
- ⇒ Loosen lock behind the blade guard ring and remove blade cover.



Fig. 106: Blade cover

Deflector

CAUTION! Risk of injury on deflector edge.

- ⇒ Remove deflector from magnetic lock and swivel it upwards.



Fig. 107: Deflector

Cover interface ports

- ➔ Cover the USB port of the display and operating unit using the captive cap.
- ➔ Cover the Ethernet port of the machine housing using the captive cap.



Fig. 108: Cover interface ports

Now the machine is ready for cleaning.

8.3 Cleaning

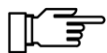

Remove the plug and protect against moisture before cleaning.

NOTICE

High-pressure cleaner!

Water penetrating the device damages electric components.

- Do not use high-pressure cleaner for cleaning. Rinse off machine using a water hose and foam without pressure.
- Clean the display and operating unit with a moist cloth only.
- The USB / Ethernet ports must be covered using a protective cap if no cable is plugged in.
- Cover the machine when cleaning surroundings using spray and/or pressurized water.

NOTICE

Dishwasher!

Dishwasher cleaning agents damage component surfaces.

- Do not clean aluminum components (also made of anodized aluminum) in the dishwasher.
- Wash parts in warm water using a soft cleaning agent. Leave to dry in the air.

Blade cleaning

- ➔ Press a wet disposable cleaning cloth against the blade surface and slowly wipe away from the center.
- ➔ Clean the back of the blade in the same manner.
- ➔ After this process, repeat using a dry disposable cleaning cloth.



Fig. 109: Blade cleaning

- ➔ Thread a moist disposable cleaning cloth from the front between blade and guard ring.
- ➔ Using your hands, turn blade and disposable cleaning cloth; while doing so, slightly press cloth against inner side of the guard ring.



Fig. 110: Blade guard ring

Fixed machine parts

- Clean, rinse and sanitize all surfaces including deflector as per cleaning plan.



Fig. 111: Machine housing

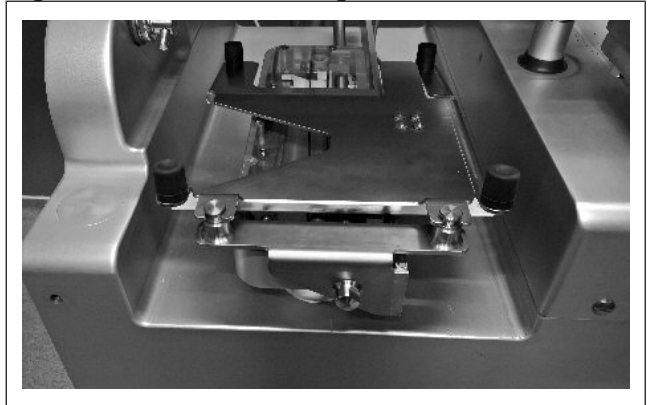

Fig. 112: VSI scale

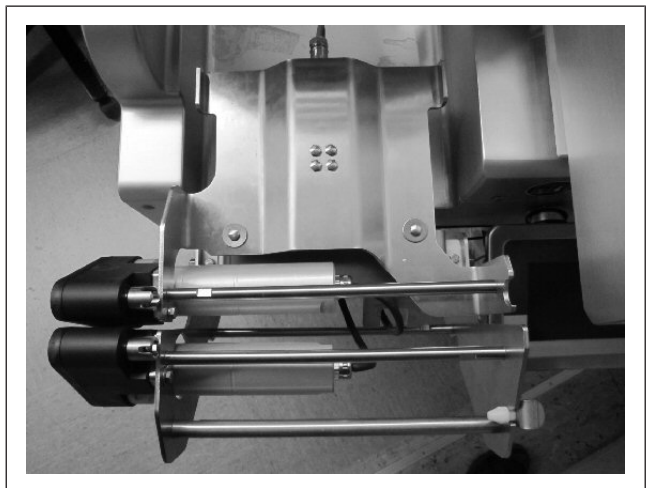

Fig. 113: VSI T scale

- ⇒ Wipe gauge plate away from blade.
Never wipe towards the blade.



Fig. 114: Gauge plate

- ⇒ Wipe carriage.
- ⇒ Leave surfaces dry in the air.

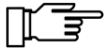

The scale must be dry to avoid a force shunt during operation.

8.4 Cleaning plan for slicers

Work steps	Recommended cleaning agents	Procedure	Cleaning devices	Notes
Preparatory measures		according to instruction manual [▶ 76]		
Disassemble all removable parts		according to instruction manual [▶ 77]		
Rough cleaning		Remove any product residues manually	Plastic deflector, plastic spatula, brush	Start immediately after production has finished, if necessary, begin with the removed parts
Cleaning	1% P3-steril	After thorough pre-rinsing with water Manually, mechanically	Brush, pan, disposable cloth	Machine and removed parts Water pressure < 6 bar
			Manual sprayer	* see comment
			Dishwasher	Removed parts except blade cover
Foam cleaning (alternative to cleaning)	TOPAZ LD1	Foam without pressure	Manual sprayer	Wear protective glasses with side protection * see comment
Acid cleaning Additional measure	squirt some Renolit Surf in the pail application time is max. 15 min.	Manually, mechanically	Brush for removing lime residue	only if required for lime residue rinse directly after cleaning
Acid foam cleaning (alternative to acid cleaning)	TOPAZ AC5	Foam without pressure	Manual sprayer	Wear protective glasses with side protection * see comment
Rinse		Rinse with drinking water	Water hose Manual sprayer	Machine and removed parts Water pressure < 6 bar

Work steps	Recommended cleaning agents	Procedure	Cleaning devices	Notes
Checking		Visually check for optical cleanliness		
Drying		rub dry or leave to dry	Disposable cloth	Leave removed parts apart from one another to allow drying
Disinfection Additional measure	P3-alcodes use in concentrated form Application time according to product data sheet	Manually, mechanically	Disposable cloth	should be completely wet
		spray	Manual sprayer	* see comment Add. safety: distance to surface when spraying, 0.30 m
Care Additional measure	Machine oil Synthetic lubricant after foam cleaning	apply to shaft and bearing according to instruction manual [▶ 100]	Disposable cloth	Product-parts that touch products must be rinsed before commencing operations
Mounting		in reverse order of disassembly, see instruction manual [▶ 92]		Personnel must have clean and disinfected hands
Precautionary measures	Cover the machine when the surroundings are cleaned with spray and/or pressurized water			



* Comment: Appropriate precautionary measures have to be taken to ensure that no damage is done to the environment!



The safety sheets and product sheets supplied with the cleaning and disinfectants must be read.
<https://safetydata.ecolab.eu/>



If cleaning agents are used that have not been recommended by the manufacturer, damage can be caused to the machine, which is no longer protected by guarantee.



This machine must be cleaned and disinfected in regular time intervals in order to meet national, legal and/or local health regulations.

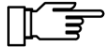

If a chemical cleaning agent except chlorine, iodine or quaternary ammonium is used, it must be applied as per instructions of the approved EPA identification.

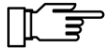

Depending on the product, there could still be a risk from viruses and bacteria which cannot be completely eliminated despite regular cleaning.

The following cleaning agents can be acquired from the Bizerba customer service:

Designation	Order no.	Packaging unit
P3-steril	50003250000	5 liters
TOPAZ LD1	94008908090	5 liters
Renolit Surf	94008963000	1 liters
TOPAZ AC5	94008908091	5 liters
P3-alcodes	50003260000	5 liters
Machine oil	94008900022	400 ml
Synthetic grease	94008908075	25 ml

8.5 Preparing the machine for operation

Attach the components as follows:

Deflector

CAUTION! Risk of injury on deflector edge.

- ⇒ Move deflector downward up to magnetic lock while observing exact positioning in recess of blade guard ring.



Fig. 115: Deflector

Blade cover

- ⇒ Hold blade cover at handle, tilt towards blade and fix into position with the stud.
- ⇒ Fasten lock behind blade guard ring.

NOTICE! Do not mix up with covers of other machines.



Fig. 116: Blade cover

Carriage

CAUTION! Risk of being crushed between carriage and housing.

- ⇒ Tilt the carriage in the direction of the arrow.
- ⇒ Using handle, screw into place on the carriage foot.

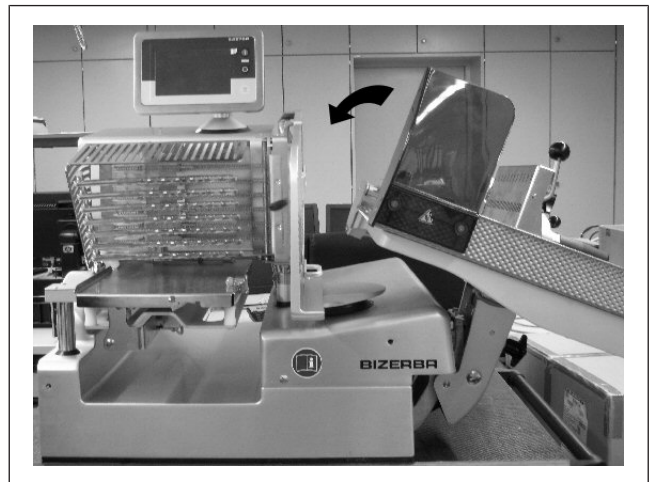

Fig. 117: Tilt carriage inwards

Feeding carriage, 400 mm carriage

CAUTION! Risk of injury at driver spikes.

- ⇒ Insert the product support plate into the channel along the sliced product holder guide and screw tight with the star grip screw.

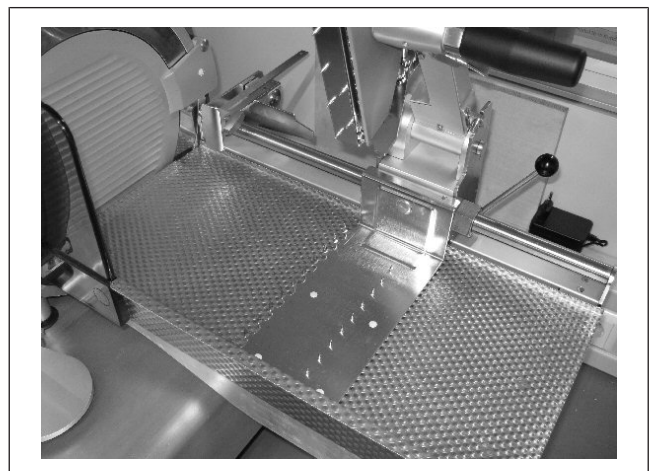

Fig. 118: Feeding carriage

Product holder, 400 mm carriage

CAUTION! Risk of jamming between product holder and gauge plate.

- ⇒ Hold on to the handle on the product holder, loosen the clamping device using the lock lever and move it downwards.
- ⇒ Position the top of the product holder at the relevant fixtures and screw tight with the star grip screw.



Fig. 119: Product holder

Product holder

- ⇒ Insert product holder in groove.
- ⇒ Screw tight using the star grip screw.

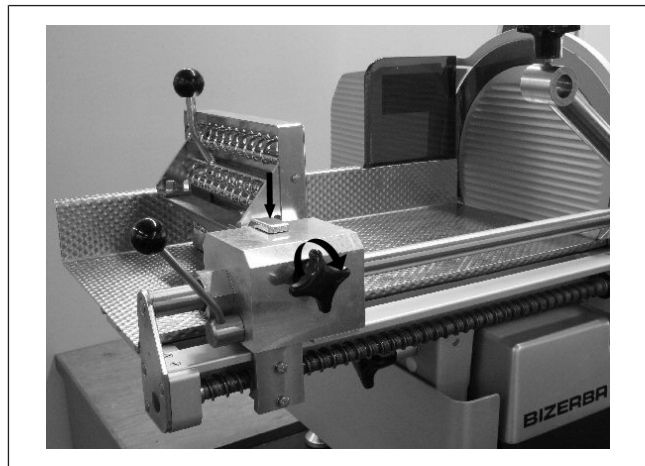

Fig. 120: Product holder

Product fixation device, vertical

- ⇒ Push product fixation device onto guide element, tighten star knob.

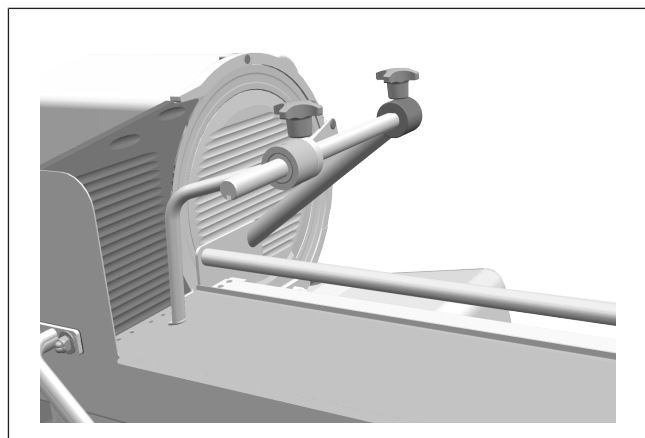

Fig. 121: Product fixation device, vertical

Product fixation device, horizontal

- ⇒ Push fixation plate in guidance from top and fasten clamp handle.

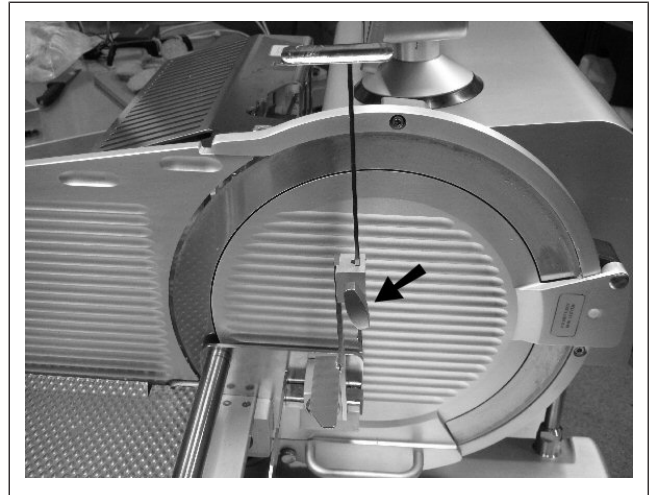

Fig. 122: Product fixation device, horizontal

Guide cam

- ⇒ Insert guide cam between the transport chains and fasten it using the clamp handle.
- ⇒ By turning the feed roller check if chains are mounted correctly.

NOTICE! Twisted guide cam or chain spikes can cause malfunctions.



Fig. 123: Guide cam

Chain frame

CAUTION! Risk of injury at chain spikes.

- ⇒ Install chain frame with swiveled in feed roller from the top in the holding fixtures and drive shaft.

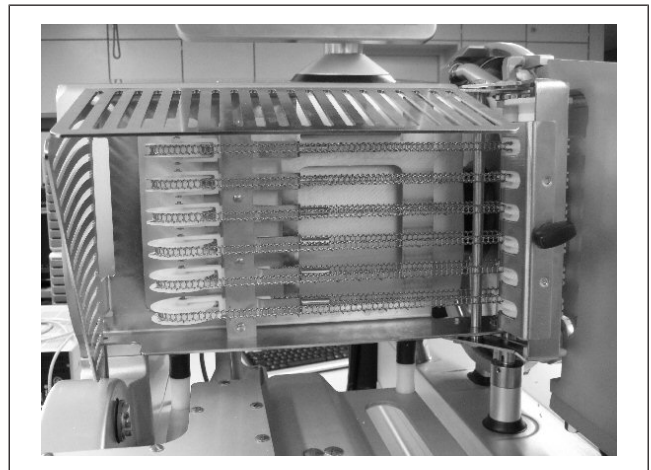

Fig. 124: Chain frame

Depositing arm

- ➔ Push depositing arm onto carriage shaft and turn until the hub catches the groove.
- ➔ Tighten.



Fig. 125: Depositing arm

Depositing table VSI, VSI W

- ➔ Insert slightly tilted depositing table backwards in guidance and push it downwards.

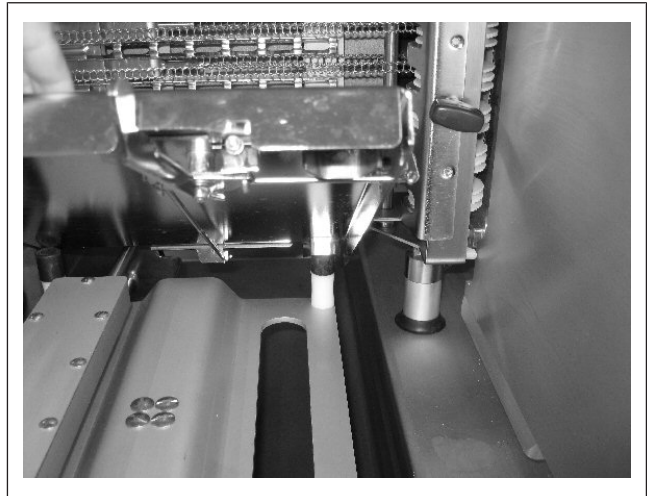

Fig. 126: Attaching the depositing table

Conveyor VSI T

- ➔ Use both hands to hold on to the sides of the conveyor belt.
- ➔ Put the belt bearing down onto the take-up pin, keeping it in a slight tilted position.

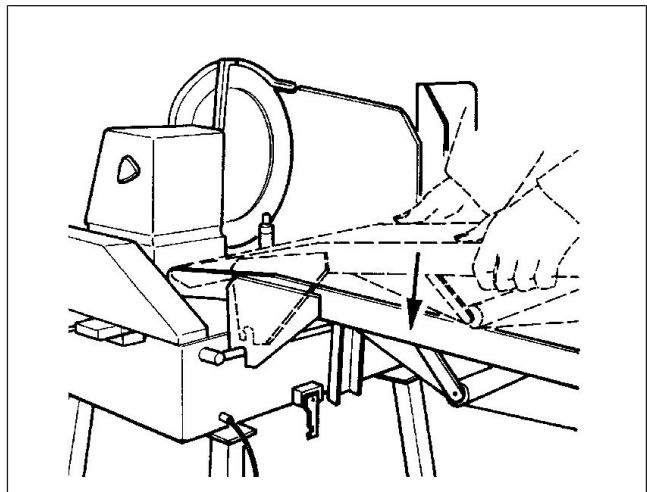

Fig. 127: Insert conveyor belt VSI T

- ⇒ Push the conveyor as far as it will go towards the coupling, if necessary turn the drive shaft until it connects with the coupling bolts.

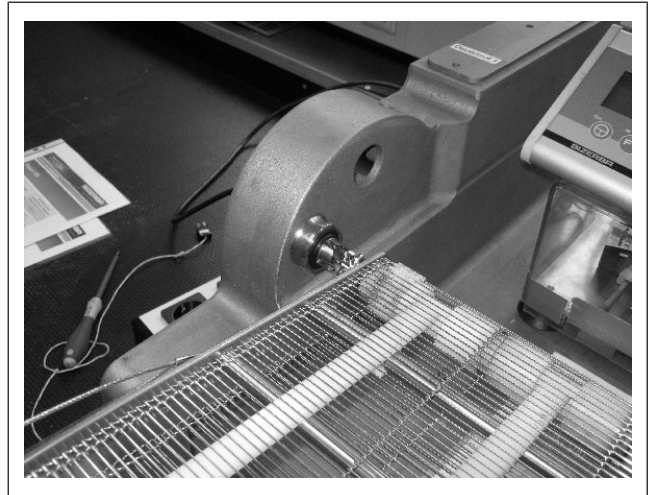

Fig. 128: Couple conveyor belt VSI T

- ⇒ Secure the conveyor belt by setting the lock at the belt support.

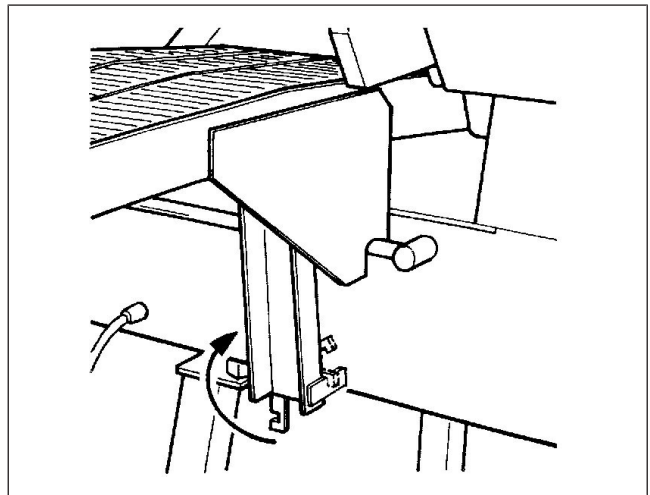

Fig. 129: Lock conveyor belt VSI T

Weighing conveyor VSI TW

- ⇒ Bring the weighing conveyor in a slightly inclined position on the left into the coupling, if necessary turn the drive shaft until it connects with the coupling bolts.
- ⇒ Place right shaft end into the guidance, lower weighing conveyor at the back.

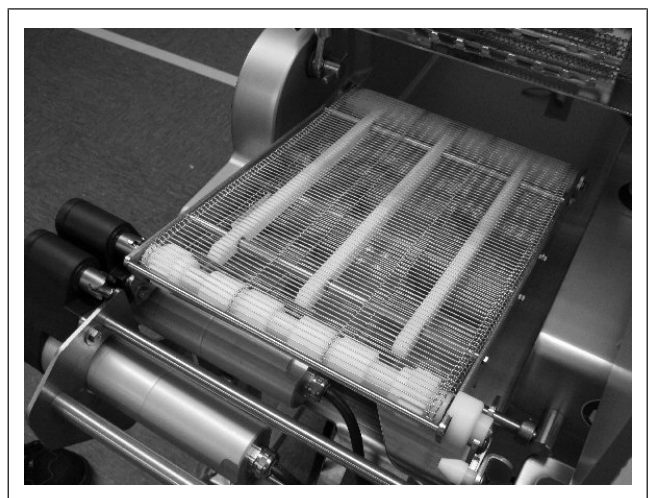

Fig. 130: Weighing conveyor

Discharge conveyor VSI TW

CAUTION! Risk of crushing fingers between belt support and conveyor.

→ Engage discharge conveyor into the belt mount from the top.

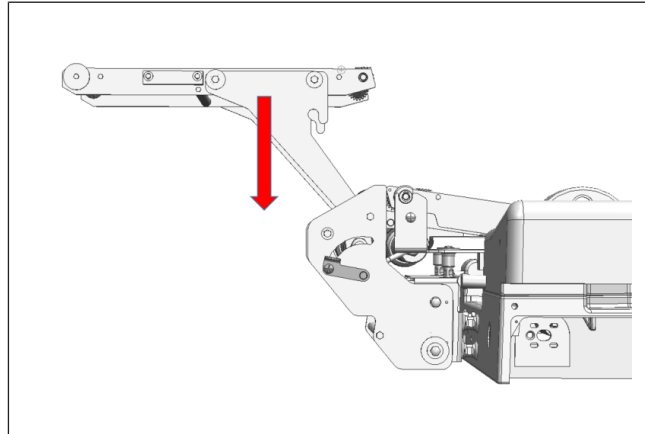

Fig. 131: Engage conveyor

→ Push conveyor to the left into the jaw clutch coupling. If necessary, turn drive shaft until it connects with the coupling bolt.

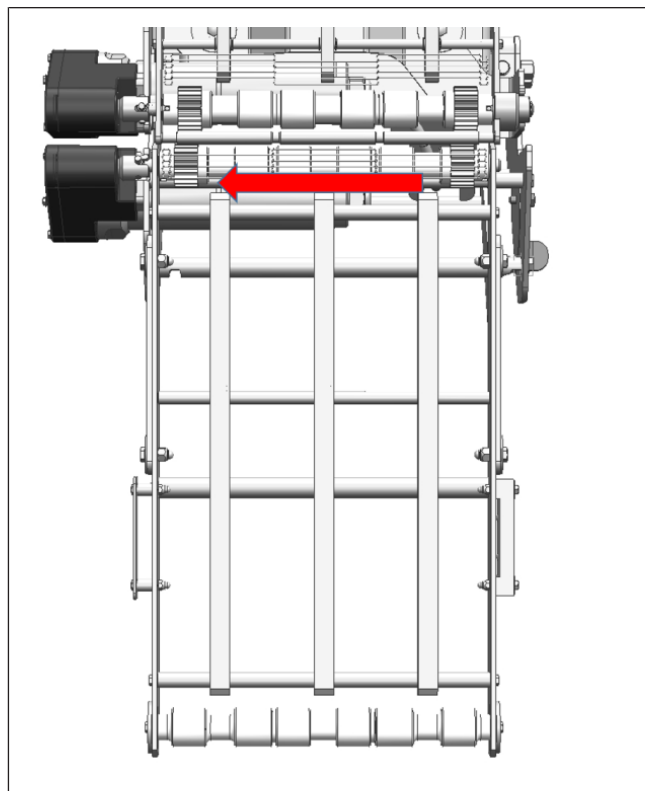

Fig. 132: Couple conveyor belt

→ Push lock at belt support towards the front.
Conveyor belt is coupled and secured.

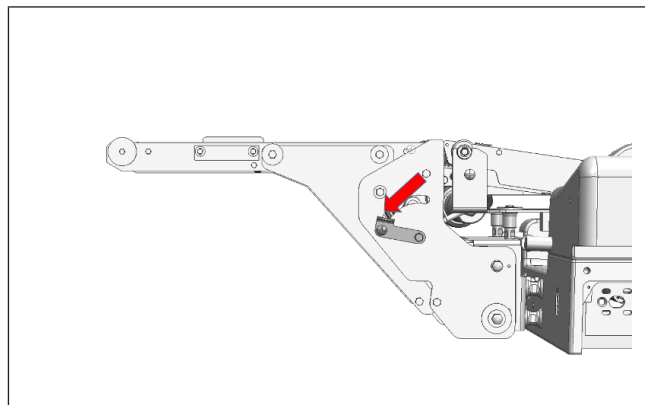

Fig. 133: Lock conveyor belt

Light sensor

- Push the top of the light barrier into the holder.



Fig. 134: Light sensor

WARNING



Missing components!

The operator can only be protected from injuries and the machine protected against damage if all the components of the machine are assembled properly.

- Check if the machine is complete before it is re-started.
- Check if components are positioned correctly and firmly.
- Only use original Bizerba spare parts and accessories.

8.6 Service and maintenance

⇒ The entire machine must be thoroughly cleaned. [▶ 76]

- ① Product holder leading axle
- ② Shaft on table guide
- ③ Ball bearing
- ④ Ball bearing
- ⑤ Guide roller (6 units)
- ⑥ Carriage shaft

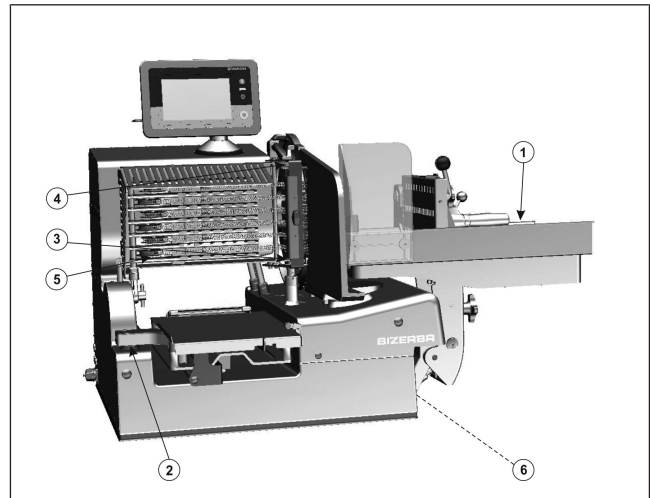

Fig. 135: Lubricate

- ⇒ After every cleaning, lubricate positions 1 to 6 lightly with oil from the accessories kit. After foam cleaning lubricate with synthetic lubricant.
- ⇒ Re-sharpen blade if necessary.
- ⇒ When necessary, clean or exchange the grinding discs. Caution. **Please, note! Left-handed thread!**



At an annular gap of more than 6 mm between blade and blade guard, the sharpener no longer has a sharpening effect and the blade has to be replaced by the Bizerba Service.

WARNING

Changing the blade!

Severe injuries and damage to property.

- For safety reasons, the blade may only be changed by Bizerba customer service.
- This also applies when using the separately available blade removal tool.
- Wear cut-proof gloves and shoes with toe caps.



8.6.1 Blade sharpening

Re-sharpening of the blade is necessary if the slicing result is unsatisfactory.

The time intervals are dependent on the wear and tear of the blade and its operating usage as also the properties and conditions of the product.

Sharpener

The sharpener identified by the machine number has been adjusted for this machine.

The device is fitted with a coarse sharpening stone and a finely grained honing stone. Dirty or greasy sharpening stones do not sharpen well.

- ⇒ Before sharpening, clean with brush and solving detergent.
- ⇒ If sharpening stones are worn, replace stones.

Replacement parts are supplied by Bizerba customer services.

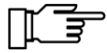

When replacing, do not confuse sharpening and honing stones.

Preparation for sharpening

	⚠ WARNING
	<p>Unprotected blade! Coming in contact with the sharp blade can lead to serious injuries.</p> <ul style="list-style-type: none"> – Wear cut-proof gloves when cleaning and sharpening. – Do not clean the blades when operating the machine.

- The machine is cleaned. The blade is clean.
- The machine is switched on.
- The main page comes up on the touch screen.

- ⇒ Press icon on the navigation bar. Instructions on the further operating procedure appear on the touch screen.
- ⇒ Confirm removal of chain frame and blade cleaning by pressing <Confirm>.
- ⇒ Confirm removal of blade from oil by pressing <Confirm>.

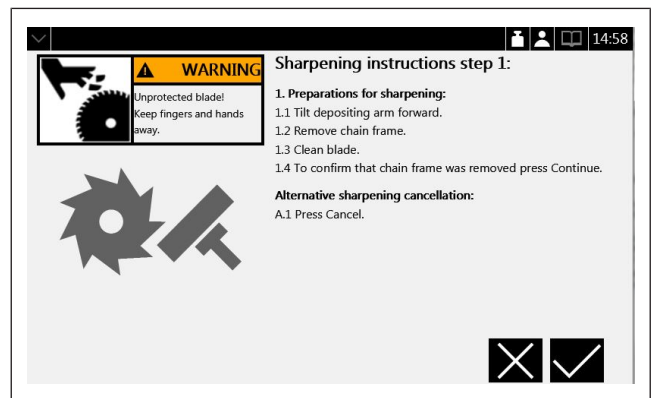

Fig. 136: Instructions on the further operating procedure

Attaching the sharpener

WARNING! Risk of injury on open blade.

- Blade is not running and gauge plate is open.
 - Sharpener marking must be at "0".
- ➔ Move carriage to relevant position.
 - ➔ Mount sharpener to gauge plate from the top.
-
- ➔ Push the sharpener and carriage towards the blade until the adapter contacts the front of the blade guard ring.
 - ➔ Keep the sharpener in this position and use the star knob to screw it to the gauge plate.



Fig. 137: Attaching the sharpener

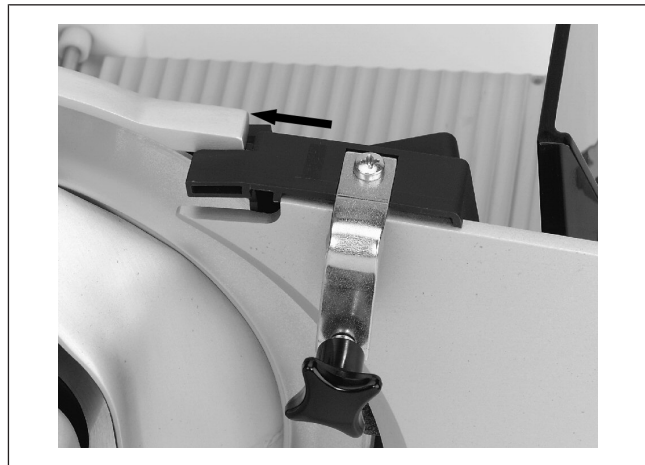

Fig. 138: Clamping the sharpener

8.6.2 Sharpening

➔ **Wear eye protection!**

Hearing protection is recommended.

- ➔ Start blade drive by pressing <Execute>.
- ➔ Set marking to "1".
The sharpening stone is engaged.
- ➔ Sharpen until right blade edge shows a burr.
- ➔ Set marking to "0".
- ➔ Stop blade drive by pressing <Execute>.
Wait until the blade finishes rotating.



Fig. 139: Marking set to "1"

Check the grinding device

- ⇒ Using a pen or pencil, touch the right edge of the blade while moving the pen from inside to outside.

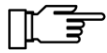

Burr must be noticeable, otherwise the sharpening procedure must be repeated.

8.6.3 Honing

- ⇒ Start blade drive by pressing <Execute>.
- ⇒ Set marking to "2".
The honing stone is engaged.
- ⇒ Hone until right-hand blade edge shows a honing bevel (approx. 3 sec.).
- ⇒ Set marking to "0".
- ⇒ Stop blade drive by pressing <Execute>.
Wait until the blade finishes rotating.



Fig. 140: Marking set to "2"

Removing sharpener

- The blade is now sharpened.

- ⇒ Pull sharpener back after loosening the star grip screw and remove to the top.
- ⇒ Confirm removal of sharpener by pressing <Confirm>.
- ⇒ On the display and operating unit press <Execute>.

The gauge plate closes.

CAUTION! Risk of crushing between gauge plate and rear wall, carriage, product holder, blade.

- ⇒ Perform cleaning. [▶ 76]
- ⇒ Prepare machine for operation. [▶ 92]

8.6.4 Checking seals and sealings

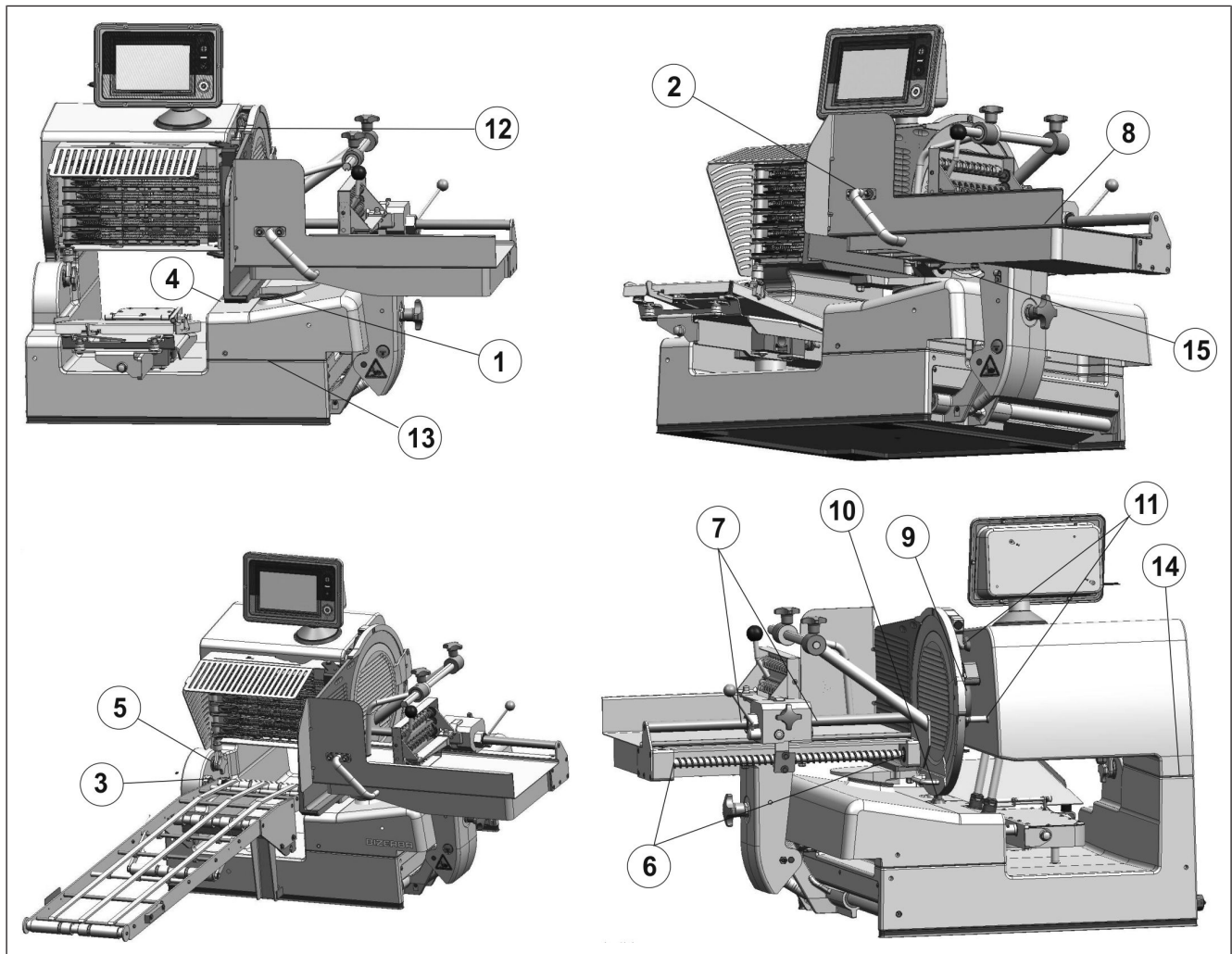



Fig. 141: Installation points for seals and sealings

Installation points for seals and sealings between the following parts:

- ① Gauge plate - machine housing
- ② Carriage plate - handle
- ③ Conveyor belt - machine housing
- ④ Chain frame - machine housing
- ⑤ Depositing arm - machine housing
- ⑥ Spindle - carriage 2x
- ⑦ Product holder guide shaft - Product holder guidance 2x
- ⑧ Carriage plate - carriage mounting
- ⑨ Blade - machine housing
- ⑩ Blade guard - machine housing
- ⑪ Blade guard - machine housing 2x
- ⑫ Display and operating unit - machine housing
- ⑬ Drive housing - machine housing
- ⑭ Drive housing - motor tower
- ⑮ Carriage mounting - carriage foot

- ⇒ Seals and gaskets 1 to 15 used in food and splash water areas need to be checked.
- ⇒ The time distance between the checks must be less than 12 months.
- ⇒ The checks need to be done by the manufacturer or one of his service agents.

	⚠ WARNING
	<p>Damaged or missing seals and sealings! Damage to health, damage to objects.</p> <p>– In case of missing or damaged sealings the slicer must no longer be operated until the damage is remedied.</p>

9 Technical data

9.1 Dimensions VSI / VSI W

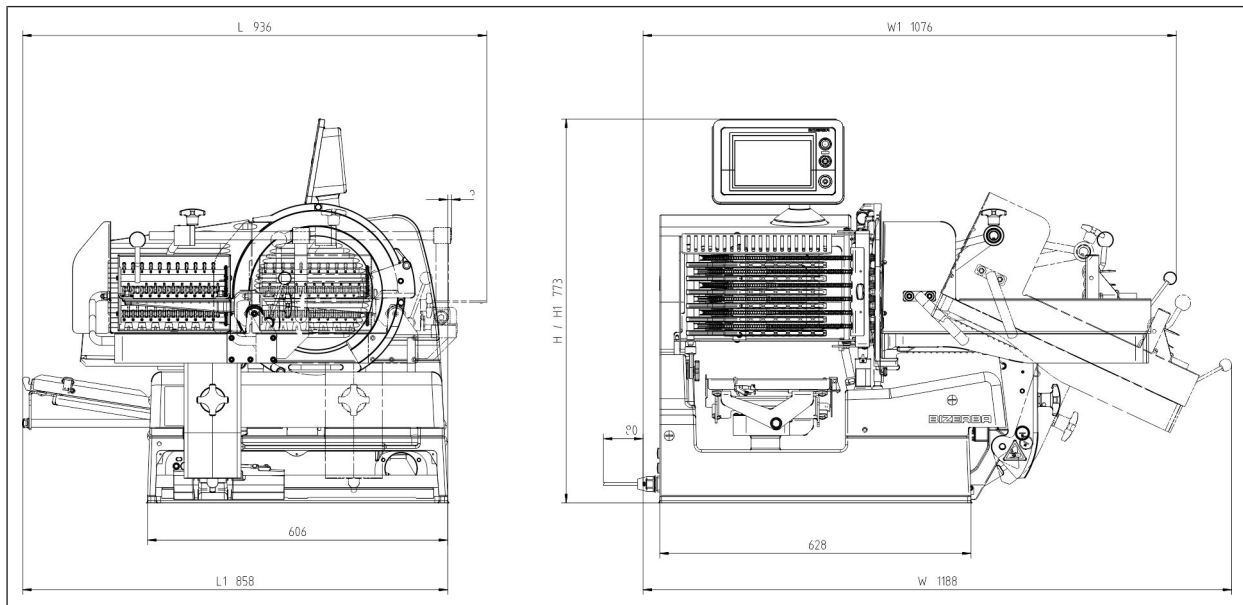

Fig. 142: Dimensions of VSI with carriage 400 mm

Installation surface

	Length x width
Installation on table	606 x 628 mm / 23.9" x 24.7"
Installation on a stand	800 x 847 mm / 31.5" x 33.3"

Work area of machine

The work area of the machine includes the area within the max. dimensions:

	Length x width x height
400 mm carriage, display at the top, without stand	936 x 1188 x 773 mm / 36.9" x 46.8" x 30.4"
600 mm carriage, display at the top, without stand	936 x 1354 x 773 mm / 36.9" x 53.3" x 30.4"

Depositing table

Length x width	340 x 250 mm / 13.3" x 9.8"
----------------	-----------------------------

Blade diameter

330 mm / 13.0"

Stand

Length x width x height	800 x 847 x 707 mm / 31.5" x 33.3" x 27.8"
-------------------------	--

Packaging

	Length x width x height
400 mm carriage, display at the top, without stand	680 x 1080 x 995 mm / 26.8" x 42.5" x 39.2"
600 mm carriage, display at the top, without stand	680 x 1375 x 995 mm / 26.8" x 54.1" x 39.2"

9.2 Dimensions VSI T

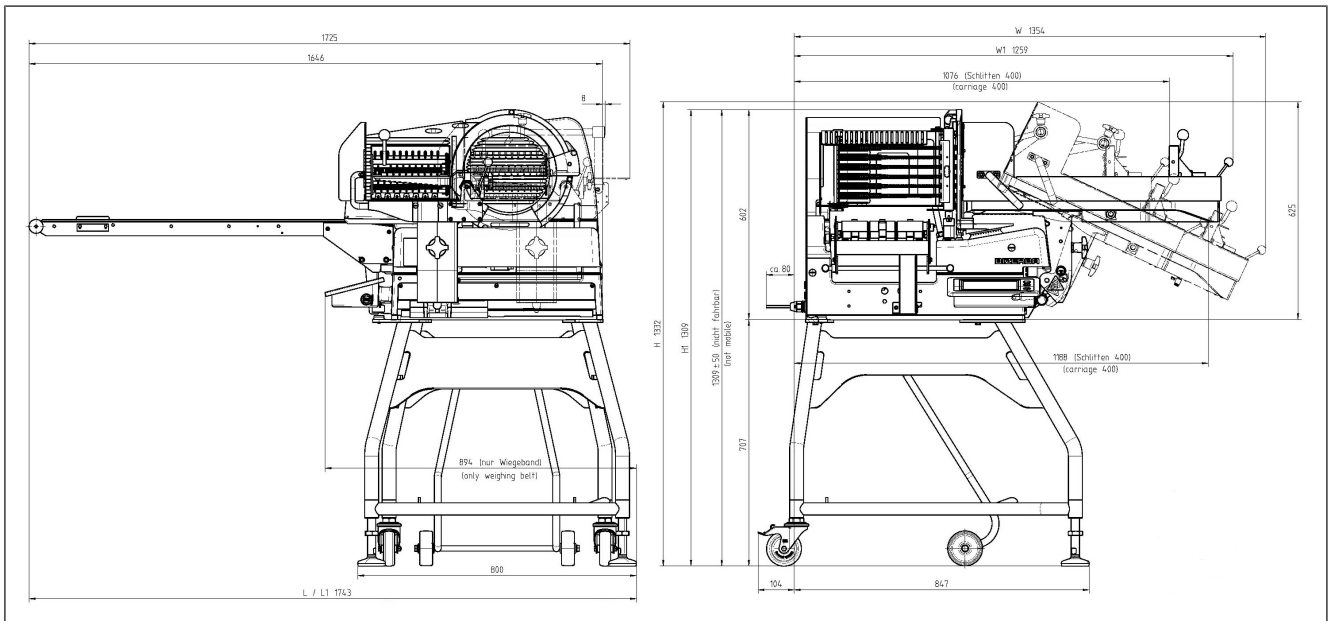

Fig. 143: Dimensions VSI T

Installation surface

	Length x width
Installation on table	606 x 628 mm / 23.9" x 24.7"
Installation on a stand	800 x 847 mm / 31.5" x 33.3"

Work area of machine

The work area of the machine includes the area within the max. dimensions:

	Length x width x height
VSI T on a stand, 600 mm carriage, display at the bottom	1743 x 1354 x 1332 mm / 68.6" x 53.3" x 52.4"
VSI T on a stand, 400 mm carriage, display at the bottom	1743 x 1188 x 1332 mm / 68.6" x 46.8" x 52.4"

Conveyor belt

	Length x width
5 portions belt, wire mesh	950 x 250 mm / 37.4" x 9.8"

Technical data

1 portion belt, wire mesh	325 x 250 mm / 12.8" x 9.8"
1 portion belt, plastic belts 30 mm	325 x 250 mm / 12.8" x 9.8"

Blade diameter

330 mm / 13.0"

Stand

Length x width x height 800 x 847 x 707 mm / 31.5" x 33.3" x 27.8"

Packaging

Length x width x height
without conveyor, without stand 680 x 1375 x 995 mm / 26.8" x 54.1" x 39.2"

9.3 Dimensions VSI TW

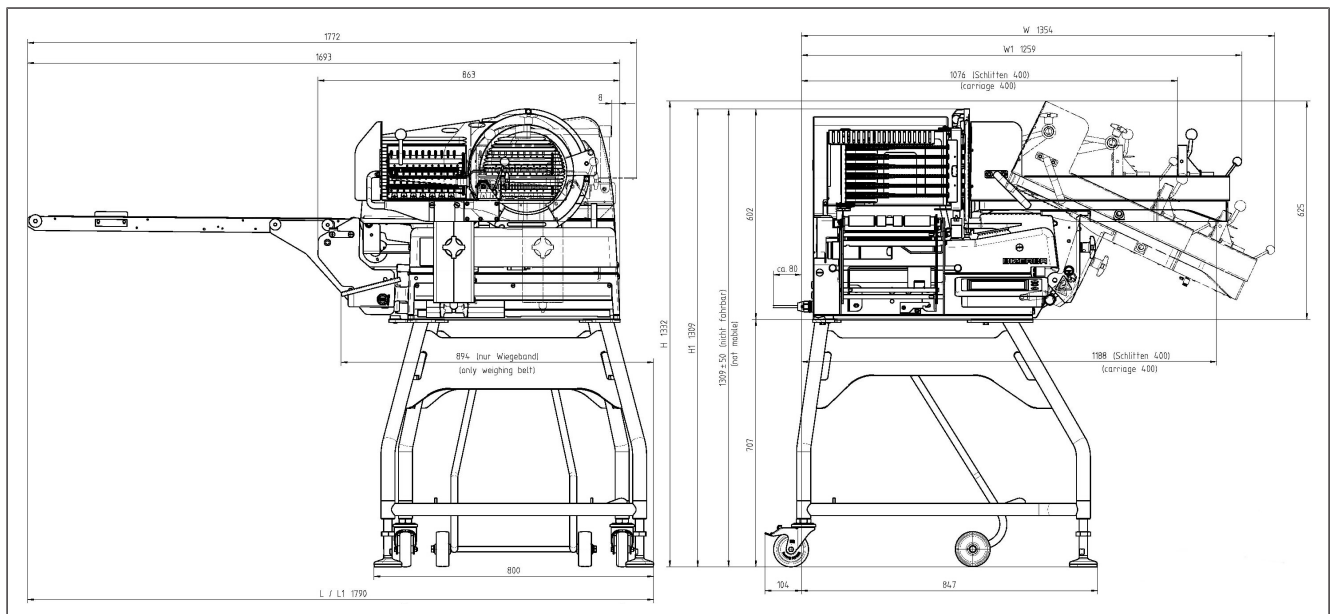

Fig. 144: Dimensions VSI TW

Installation surface

	Length x width
Installation on table	606 x 628 mm / 23.9" x 24.7"
Installation on a stand	800 x 847 mm / 31.5" x 33.3"

Work area of machine

The work area of the machine includes the area within the max. dimensions:

	Length x width x height
VSI TW on a stand, 600 mm carriage, display at the bottom	1790 x 1354 x 1332 mm / 70.5" x 53.3" x 52.4"

VSI TW on a stand, 400 mm carriage, display at the bottom 1790 x 1188 x 1332 mm / 70.5" x 46.8" x 52.4"

Conveyor belt

	Length x width
5 portions belt, wire mesh	950 x 250 mm / 37.4" x 9.8"
1 portion belt, wire mesh	325 x 250 mm / 12.8" x 9.8"
1 portion belt, plastic belts 30 mm	325 x 250 mm / 12.8" x 9.8"

Blade diameter

330 mm / 13.0"

Stand

Length x width x height 800 x 847 x 707 mm / 31.5" x 33.3" x 27.8"

Packaging

	Length x width x height
without conveyor, without stand	680 x 1375 x 995 mm / 26.8" x 54.1" x 39.2"

9.4 Technical data

	VSI / VSI W	VSI T	VSI TW
Product size	Height: 50 - 180 mm / 2.0" - 7.1" Width: 50 - 240 mm / 2.0" - 9.4" Round: Ø 50 - 180 mm / 2.0" - 7.1" Length: 600 mm / 23.6" with 600 mm carriage Length: 400 mm / 15.7" with 400 mm carriage		
Maximum load	20.0 kg / 45 lb or a smaller weight which is indicated in the status bar depending on the product width and number of carriage strokes		
Slice thickness	0.3 - 12 mm / 0.01" - 0.47" motorized adjustment		
Slicing performance	30 - 80 slices per minute, depending on depositing type and product to be sliced some variants are limited to up to 55 cuts per minute		
Blade speed	100 - 400 rpm		
Weight machine	approx. 122 kg / 269.0 lb	approx. 137 kg / 302.0 lb	approx. 137 kg / 302.0 lb
Gross weight	approx. 154 kg / 339.5 lb	approx. 176 kg / 388.0 lb	approx. 176 kg / 388.0 lb
Weight, stand	approx. 32 kg / 70.5 lb		
Portion scale		without scale	
Weighing range	50 - 2000 g / 0.1 - 4 lb		50 - 2000 g / 0.1 - 4 lb
Interval	1 g / 0.002 lb		1 g / 0.002 lb
Noise level during normal operation	the noise emission value according to DIN EN 11202 at the workstation is lower than 70 dB(A), related to the entire machine		
Noise level during sharpening	the noise level reaches temporarily up to 82 dB(A)		
Types of current, voltages, power consumption	see identification plate		
IP rating	IPx5		

9.5 Power supply

Technical data of power supply

– **Mains supply**

Single-phase alternating current, see rating plate

– **Permissible mains voltage tolerance (static) normal**

At 100 to 400 V: +6% to - 10% of nominal value

In case of deviations of >10 ms the machine turns off.

– **Mains frequency: 50 (60) Hz**

Permissible tolerance of mains frequency: +2% to -2% of nominal value

Admissible distortion factor of mains voltage: less than or equal to 5 %

– Leakage current protective conductor max.: 3.5 mA

9.6 Ambient conditions

– **Ambient temperature**

for operation and storage: -10 to +40°C (+14 to +104 degF)

– **Humidity**

IPX5 rating. High air humidity and the formation of condensation water can result in damage to the machine.

– **Relative humidity**

for operation and storage: 85 % (condensation of the unit is not permissible)

– **Air convection**











Free air convection must be able to form around the device in order to avoid overheating.













– **Required lighting**













500 Lux



10 Attachment

10.1 Parameter defaults and input ranges

Parameter symbol	Parameter name	Default value	Minimum	Maximum
	Depositing type	 Stacking		
	Depositing offset crosswise	0 mm	0 mm	190 mm
	Depositing offset lengthwise	0 mm	0 mm	236 mm
	Depositing area width	240 mm	100 mm	500 mm
	Depositing area length	120 mm	100 mm	500 mm
	Depositing area height	90 mm	10 mm	90 mm
	Number of slices	90 slices per stack 10 slices per shingle 12 slices per circular pattern	1	9999
	Slice thickness	1.0 mm 1.2 mm for circular pattern 0.6 mm for shaving	0.3 mm	12.0 mm
	Shingling distance, shingling lengthwise	6 mm	3 mm	236 mm
	Shingling distance, shingling crosswise	4 mm	3 mm	190 mm

Parameter symbol	Parameter name	Default value	Minimum	Maximum
	Shingling length, shingling lengthwise	240 mm	50 mm	286 mm
	Shingling length, shingling crosswise	240 mm	50 mm	240 mm
	Number of portions	9999	1	9999
	Product width	240 mm 80 mm for circular pattern	50 mm	240 mm
	Product height	180 mm 80 mm for circular pattern	50 mm	180 mm
	Product length	600 mm	0 mm	600 mm
	Product weight	6 kg	0 kg	20 kg
	Target weight	900 g for stacking 100 g for shingling 122 g for circular pattern 60 g for shaving	20 g	2000 g
	Reference weight	10.0 g/mm 8.5 g/mm for circular pattern	1.0 g/mm	100.0 g/mm
	Number of rows lengthwise	1	1	4
	Row spacing crosswise, stacks	10 mm	0 mm	100 mm
	Row spacing crosswise, shingles lengthwise	10 mm	-100 mm	100 mm























Parameter symbol	Parameter name	Default value	Minimum	Maximum
	Number of rows crosswise	1	1	4
	Row spacing lengthwise, stacks	10 mm	0 mm	100 mm
	Row spacing lengthwise, shingles crosswise	10 mm	-100 mm	100 mm
	Circular diameter	240 mm with 12 slices 120 mm with 9 slices 60 mm with 6 slices	Product height Product width	240 mm
	Number of layers	1	1	20
	Automatically close gauge plate	On		
	Blade speed	250 min ⁻¹	100 min ⁻¹	400 min ⁻¹
	First Cut Program	Conveyor belt: 3 slices Table: disabled	1 slice	10 slices
	First cut discharge	Discharge to the front		
	Speed Discharge	400 mm/s	100 mm/s	560 mm/s
	Number of carriage strokes	50 min ⁻¹	30 min ⁻¹	80 min ⁻¹ 55 min ⁻¹
	Stack depositing correction step correction factor	0	-10	10

Parameter symbol	Parameter name	Default value	Minimum	Maximum
	Product feed offset	0.1 mm	-0.5 mm	0.5 mm
	Gauge plate offset	0.0 mm	-0.5 mm	0.5 mm

10.2 Set programs























Each machine has standard PLUs saved. These PLUs are write protected and can not be changed by the user. Each PLU stands for a depositing pattern.

VSI depositing on table

PLU number			 mm	 g		 min ⁻¹	 mm	 mm	 mm	 mm		 mm	
a1		50	1.8	900	1	50	180	180	-	-	1	-	-
a2		50	1.8	900	1	50	180	180	-	-	2	30	-
a3		8	1.8	100	9999	50	180	180	240	8	1	-	1
a4		8	1.8	100	9999	50	80	180	240	8	3	0	1
a5		8	1.8	100	9999	50	80	180	240	8	3	0	5
a6		5	1.8	100	9999	50	180	180	220	10	1	-	1
a7		5	1.8	100	9999	50	180	80	220	10	3	10	1
a8		5	1.8	100	9999	50	180	180	220	10	1	-	5
a9		5	1.8	100	9999	50	180	80	220	10	3	10	5
a10		11	0.9	100	1	45	180	180	240	6	1	-	1

The reference weight for all standard PLUs is 10.0 g/mm.

VSI T depositing on conveyor

PLU number			 mm	 g		 min ⁻¹	 mm	 mm	 mm	 mm		 mm	 mm
a1		33	1.8	100	9999	50	180	180	-	-	1	-	0
a2		50	1.2	100	9999	50	180	180	-	-	1	-	0
a3		8	1.8	100	9999	50	180	180	240	8	1	-	0
a4		8	1.8	100	9999	50	180	180	240	8	1	-	30
a5		14	1.2	100	9999	50	180	180	240	4	1	-	0
a6		infinite	1.8	100	9999	50	80	180	infinite	8	1	0	0
a7		5	1.8	100	9999	50	180	180	200	5	1	-	0
a8		6	1.5	100	9999	50	180	180	240	12	1	-	30
a9		12	1.5	100	9999	50	180	180	240	5	1	-	0
a10		11	0.9	100	9999	45	180	180	240	6	1	-	0

The reference weight for all standard PLUs is 10.0 g/mm.

The number of layers for all standard PLUs is 1.

10.3 Checklist installation and start-up

Installation requirements to be met by customer

	Done
The machine and components to be installed are located at the place of installation.	<input type="checkbox"/>
Machines for which the power is supplied via power plug (Schuko, CEKON, Perilex, ...) must be fitted with a suitable power socket within the connection range (max. distance of 1 m) of the machine allowing the machine to be connected with the provided power cable. The power plug must always be accessible to the Bizerba service technician at any time since it functions as a supply circuit disconnect in case of a repair. It is not permitted to convert machines fitted with factory-provided power plug (Schuko, CEKON, Perilex...) to a permanent connection by cutting off the power plug.	<input type="checkbox"/>
For machines which are provided with a permanently connected power supply by the factory a suitable supply circuit disconnect is provided for each machine.	<input type="checkbox"/>
The supply circuit disconnect is accessible to the Bizerba service technician at any time and w/o tools (ladder etc.).	<input type="checkbox"/>
Machines with eService function require a suitable network socket being mounted within the connection range of the machine (max. distance of 2 m). The machine is connected to the customer network via the supplied network cable.	<input type="checkbox"/>
Network settings have been adjusted accordingly and relevant customer network functions have been enabled. Information on parametrization of the machine's LAN interface (TCP/IP address, subnet, Gateway) are available.	<input type="checkbox"/>

Scope of performance regarding installation

	Done
Installation between Bizerba and end customer coordinated.	<input type="checkbox"/>
Machines and components were unpacked and packaging returned.	<input type="checkbox"/>
Machine has been correctly installed and aligned.	<input type="checkbox"/>
Machine is connected to customer provided socket.	<input type="checkbox"/>
Machine is connected to network by customer provided socket.	<input type="checkbox"/>
The LAN interface parameters (TCP/IP address, subnet, Gateway) provided by the customer are set in the machine. Remote access tested.	<input type="checkbox"/>
Functionality of machine and provided components tested, trial run and optimizations carried out.	<input type="checkbox"/>

	Done
The horizontal setup of the machine was checked by means of a spirit level or during setup on the stand with the bubble.	<input type="checkbox"/>
Scale recalibrated and functioning tested.	<input type="checkbox"/>
Electrical safety meets relevant country-specific regulations. (In Germany DIN-VDE 0701)	<input type="checkbox"/>
<p>Staff was instructed.</p> <ul style="list-style-type: none"> – Display and operating unit – Five PLUs were created together with customer – Explain how to bring blade in cleaning position – Maintenance, care, cleaning as described in instruction manual – Disassembly of the parts that require cleaning and cleaning of the machine – Hazard warnings, warnings and safety instructions included in the instruction manual were discussed – LED between the ON / OFF switches lights up as soon as the machine is switched on. It does not indicate whether the blade is running or not – Information on blade sharpening by using sharpening service, disassembly of blade 	<input type="checkbox"/>
Installation and training are approved and signed on service report.	<input type="checkbox"/>

Date:

Signature service technician:

Signature customer: