



COq Convection Oven

SERIES: COQ

Operation Manual



BKI LIMITED WARRANTY

PO Box 80400 • Simpsonville, SC 29680-0400 • USA
(864) 963-3471 • Toll Free: (800) 927-6887 • Fax: (864) 963-5316

WHAT IS COVERED

This warranty covers defects in material and workmanship under normal use, and applies only to the original purchaser providing that:

- The equipment has not been accidentally or intentionally damaged, altered or misused;
- The equipment is properly installed, adjusted, operated and maintained in accordance with national and local codes, and in accordance with the installation and operating instructions provided with this product.
- The serial number rating plate affixed to the equipment has not been defaced or removed.

WHO IS COVERED

This warranty is extended to the original purchaser and applies only to equipment purchased for use in the U.S.A.

COVERAGE PERIOD

- Warranty claims must be received in writing by BKI within one (1) year from date of installation or within one (1) year and three (3) months from date of shipment from the factory, whichever comes first.
- COB Models: One (1) Year limited parts and labor.
- COM Models: Two (2) Year limited parts and labor. COM convection ovens also have a two (2) year door warranty.
- COI Models: Two (2) Year limited parts and labor. Five (5) Year limited door warranty.
- BevLes Products: Two (2) Year limited parts and labor.
- Warranty period begins the date of dealer invoice to customer or ninety (90) days after shipment date from BKI, whichever comes first.

WARRANTY COVERAGE

This warranty covers on-site labor, parts and reasonable travel time and travel expenses of the authorized service representative up to (100) miles round trip and (2) hours travel time and performed during regular, weekday business hours.

EXCEPTIONS

Any exceptions must be pre-approved in advance and in writing by BKI. The extended door warranty on convection ovens years 3 through 5 is a parts only warranty and does not include labor, travel, mileage or any other charges.

EXCLUSIONS

- Negligence or acts of God,
- Thermostat calibrations after (30) days from equipment installation date,
- Air and gas adjustments,
- Light bulbs,
- Glass doors and door adjustments,
- Fuses,
- Adjustments to burner flames and cleaning of pilot burners,
- Tightening of screws or fasteners,
- Failures caused by erratic voltages or gas suppliers,
- Unauthorized repair by anyone other than a BKI Factory Authorized Service Center,
- Damage in shipment,
- Alteration, misuse or improper installation,
- Thermostats and safety valves with broken capillary tubes,
- Freight - other than normal UPS charges,
- Ordinary wear and tear,
- Failure to follow installation and/or operating instructions,
- Events beyond control of the company.

INSTALLATION

Leveling, as well as proper installation and check out of all new equipment - per appropriate installation and use materials - is the responsibility of the dealer or installer, not the manufacturer.

REPLACEMENT PARTS

BKI genuine Factory OEM parts receive a (90) day materials warranty effective from the date of installation by a BKI Factory Authorized Service Center.

Warranty is in lieu of all other warranties, expressed or implied, and all other obligations or liabilities on the manufacturer's part. BKI shall in no event be liable for any special, indirect or consequential damages, or in any event for damages in excess of the purchase price of the unit. The repair or replacement of proven defective parts shall constitute a fulfillment of all obligations under the terms of this warranty.

Asia • Europe • Latin America • North America



Table of Contents

Table of Contents	1
Introduction	2
Safety Precautions	2
Safety Signs and Messages	2
Safe Work Practices	3
Safety Decals	5
Health And Sanitation Practices	6
Food Handling	6
Storage Of Raw Meats	6
Coding Cooked Foods	6
Storage Of Prepared Foods	6
Operation	7
Controls and Indicators	7
CP0046 Basic TOUCH Tec Controller Operation	9
Basic Setup Editing	9
Cook Recipe Editing	10
Cooking	11
CP0058 Color TOUCH Tec Controller Operation	12
Features	12
Basic Setup Editing	13
USB Drive Usage	14
Controller Configuration	15
Recipe Editing	16
Cooking	17
Cooking Suggestions	18
Installation	19
Unpacking and Handling	19
Location and Clearance	19
Extraction	19
Wiring	19
General Guidelines	21
Guidelines for European Appliances	21
Operating	21
Safety Cut-Out	21
Maintenance	22
Scheduled Maintenance	22
Oven Cleaning (Daily)	22
Troubleshooting	24
Component Replacement	26
Light Bulb	26
Fuse Replacement	26
Temperature Probe	27
Pushbutton Switch Contact Blocks	27
Contactors	28
Controller	28
High Limit Thermostat	29
Fan Blade	30
Fan Motor	30
Fan Cover Micro Switch	30
Heating Elements	31
Heating Elements	32
Parts List	33
Wiring Diagrams	44

Introduction

Congratulations! You have chosen a **Convection Oven** that will give you many years of fine service from the original manufacturer, **BKI**.

The **BKI** name and trademark on this unit assures you of the finest in design and engineering -- that it has been built with care and dedication -- using the best materials available. Attention to the operating instructions regarding proper installation, operation, and maintenance will result in long lasting dependability to insure the highest profitable return on your investment.

NOTICE

PLEASE READ THIS ENTIRE MANUAL BEFORE OPERATING THE UNIT. If you have any questions, please contact your BKI Distributor. If they are unable to answer your questions, contact the BKI Technical Service Department, toll free: 1-800-927-6887. Outside the U.S., call 1-864-963-3471.

Safety Precautions

Always follow recommended safety precautions listed in this manual. Below is the safety alert symbol. When you see this symbol on your equipment, be alert to the potential for personal injury or property damage.

**Safety Signs and Messages**

The following Safety signs and messages are placed in this manual to provide instructions and identify specific areas where potential hazards exist and special precautions should be taken. Know and understand the meaning of these instructions, signs, and messages. Damage to the equipment, death or serious injury to you or other persons may result if these messages are not followed.

⚠ DANGER

This message indicates an imminently hazardous situation, which, if not avoided, will result in death or serious injury.

⚠ WARNING

This message indicates a potentially hazardous situation, which, if not avoided, could result in death or serious injury.

⚠ CAUTION

This message indicates a potentially hazardous situation, which, if not avoided, may result in minor or moderate injury. It may also be used to alert against unsafe practices.

NOTICE

This message is used when special information, instructions or identification are required relating to procedures, equipment, tools, capacities and other special data.

Safe Work Practices

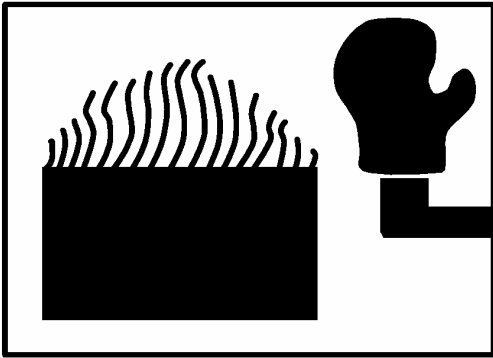

Wear Safe Clothing Appropriate To Your Job

Always wear your insulated mitts when handling hot racks or touch any hot metal surface. If you lose or damage your mitts, you can buy new ones at your local restaurant equipment supply store or from your local BKI Distributor.

Never wear loose clothing such as neckties or scarves while operating this equipment. Keep loose hair tied back or in a hair net while operating this equipment.

Always wear appropriate personal protection equipment during the cleaning process to guard against possible injury from hot cleaning solution.

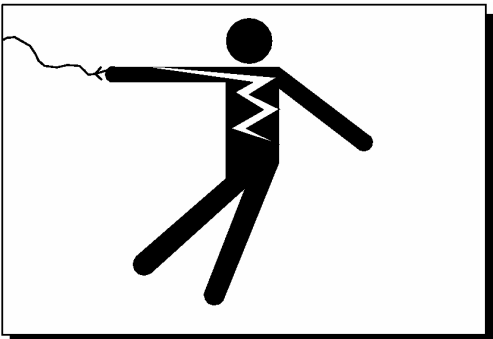

Beware of High Voltage

This equipment uses high voltage. Serious injury can occur if you or any untrained or unauthorized person installs, services, or repairs this equipment. Always use an Authorized Service agent to service your equipment.

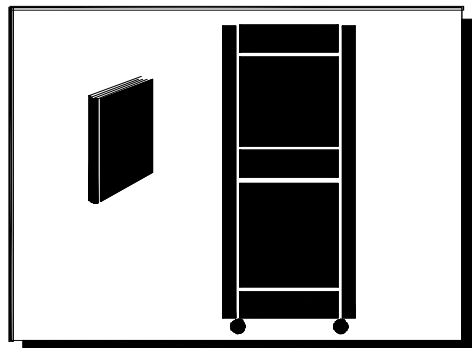

Keep this manual with the Equipment

This manual is an important part of your equipment. Always keep it near for easy access.

If you need to replace this manual, contact:

BKI
 Technical Services Department
 P.O. Box 80400
 Simpsonville, S.C. 29680-0400
 Or call toll free: 1-800-927-6887
 Outside the U.S., call 864-963-3471



Protect Children

Keep children away from this equipment. Children may not understand that this equipment is dangerous for them and others.

NEVER allow children to play near or operate your equipment.

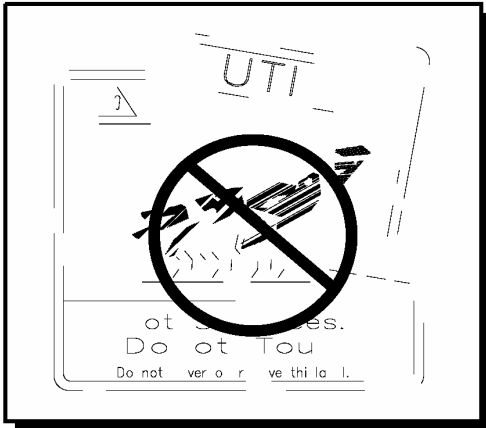

Keep Safety Labels Clean and in Good Condition

Do not remove or cover any safety labels on your equipment. Keep all safety labels clean and in good condition. Replace any damaged or missing safety labels. Refer to the Safety Labels section for illustration and location of safety labels on this unit.

If you need a new safety label, obtain the number of the specific label illustrated on page 5, then contact:

BKI
Technical Services Department
P.O. Box 80400
Simpsonville, S.C. 29680-0400
Or call toll free: 1-800-927-6887
Outside the U.S., call 864-963-3471

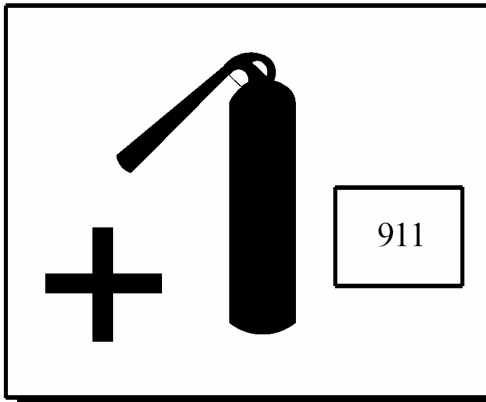

Be Prepared for Emergencies

Be prepared for fires, injuries, or other emergencies.

Keep a first aid kit and a fire extinguisher near the equipment. You must use a 40-pound Type BC fire extinguisher and keep it within 25 feet of your equipment.

Keep emergency numbers for doctors, ambulance services, hospitals, and the fire department near your telephone.

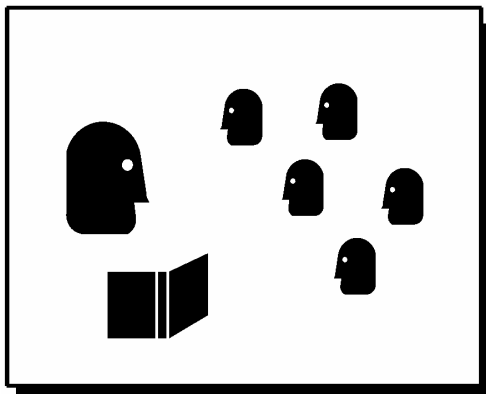

Know your responsibilities as an Employer

- Make certain your employees know how to operate the equipment.
- Make certain your employees are aware of the safety precautions on the equipment and in this manual.
- Make certain that you have thoroughly trained your employees about operating the equipment safely.
- Make certain the equipment is in proper working condition. If you make unauthorized modifications to the equipment, you will reduce the function and safety of the equipment.

Safety Decals

N0166

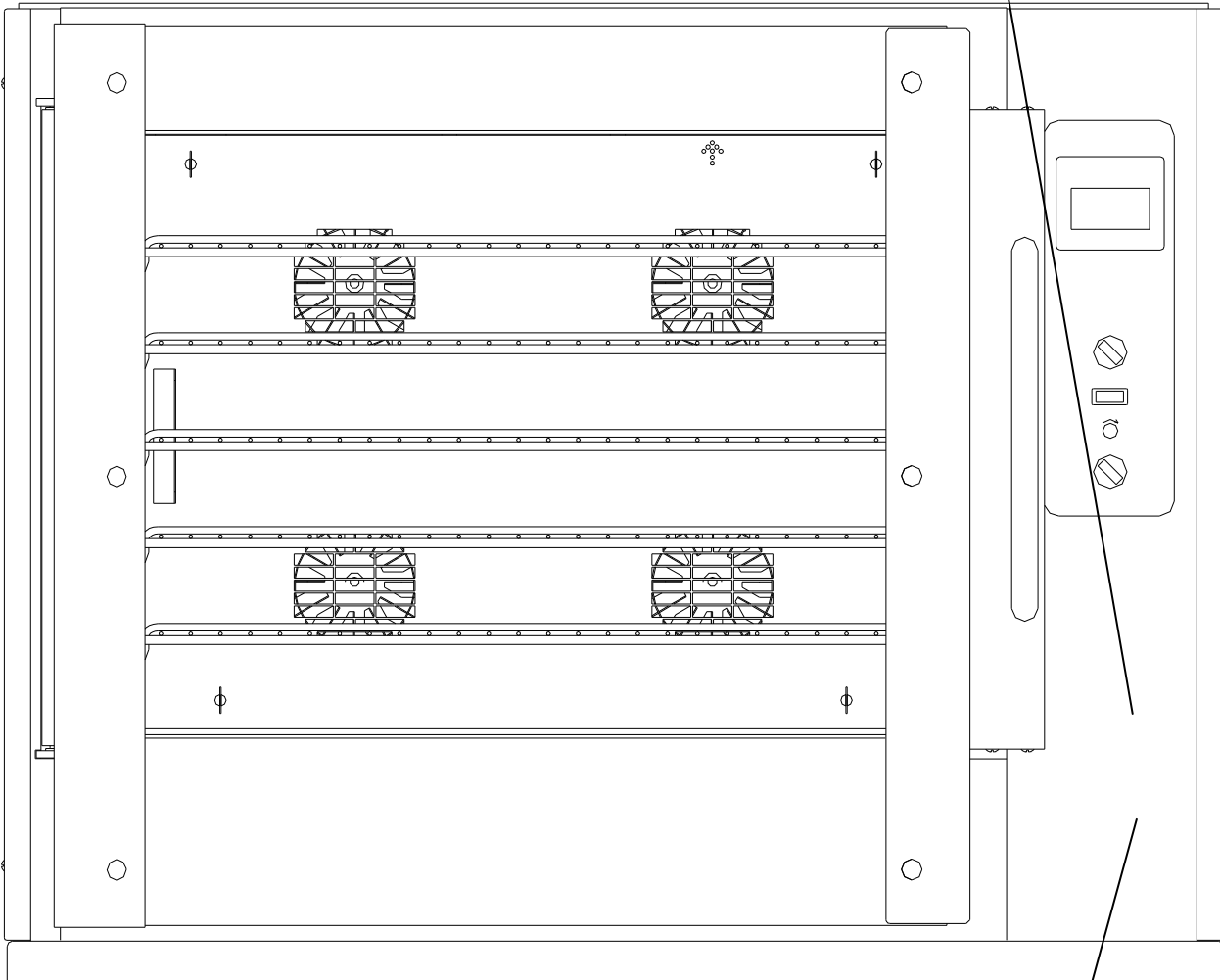

N0202



OPERATOR'S SIDE

Health And Sanitation Practices

BKI ovens are manufactured to comply with health regulations and are tested and certified to UL[®], CUL[®], and NSF[®] standards. You must operate the equipment properly using only quality products and use meat thermometers to insure meats are thoroughly cooked.

Food Handling

- Wash hands thoroughly in warm, soapy water after handling raw poultry or meats.
- Clean and sanitize all utensils and surfaces that have been in contact with raw products.
- **Never** place cooked meats on the same surfaces used to prepare raw meats, unless the area has been thoroughly cleaned and sanitized.

Storage Of Raw Meats

- Designate an area or shelf strictly for the storage of all raw meats to be used in the oven.
- Raw product must always be stored at temperatures below 38° F. (3° C.).
- **Never** store or mix raw foods above cooked foods, as this is a health hazard. The drippings from raw foods contaminate cooked or processed foods.
- All chicken and chicken parts to be stored overnight must be thoroughly iced down and refrigerated.

Coding Cooked Foods

All products cooked during the day should be sold the same day.

NOTE: It is not the intent of the cooking program to have unsold merchandise at the end of the cooking day. Follow your company's procedures for the handling of any leftover product.

Storage Of Prepared Foods

- Cold foods should be kept at or below 38° F. (3° C.).
- Hot foods must be maintained to meet local health codes, usually a minimum 145° F. (63° C.).

Operation

Controls and Indicators

Refer to the figure and table below for an explanation of controls and indicators.

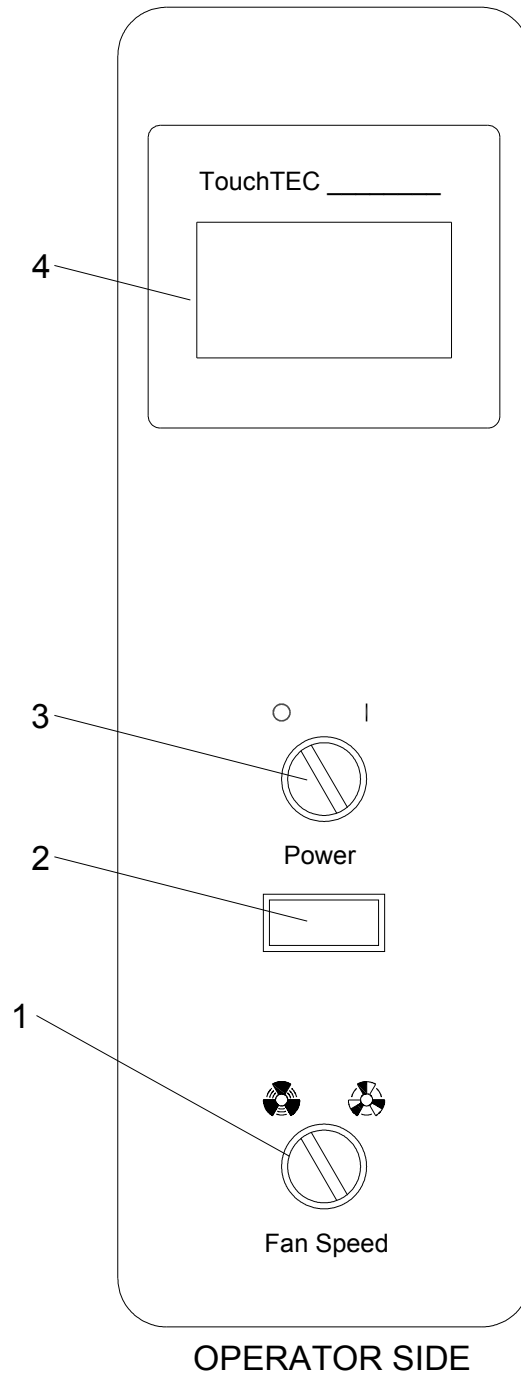

Item #	Description	Function
1	Fan Speed Switch	Changes the oven fan speed between high and low. Turn switch to the desired fan speed.
2	Main Power Isolator Light	This light illuminates to indicate that power is being applied to the oven from the Main Power Isolator (Circuit Breaker).
3	Main Power Switch	Turns power to the entire unit on or off. When placed in the on position, the Touchscreen controller is powered and the lights illuminate. When placed in the off position, power is removed from the entire unit.
4	Analog Touchscreen Controller	Used for operation and programming of the oven. A built-in beeper is used to indicate touchscreen presses and other oven functions. It has 15 programmable cooking recipes.

CP0046 Basic TOUCH Tec Controller Operation



Screen displays when oven main power switch is turned on.

Touch anywhere on screen to activate controller.

All functions of the controller are accessed from this screen.

Following are instructions for -
Basic Setup Editing,
Cook Recipe Editing &
Cooking

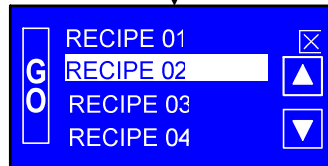

Touching **X** for 3 seconds turns controller Off.

Use **▲** (up) and **▼** (down) arrows to highlight desired Recipe.

Basic Setup Editing

Start the controller and follow the procedure below to Edit the Basic Setup.

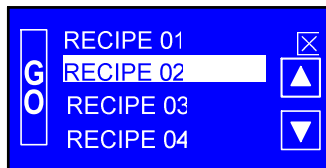

Touch any highlighted Recipe for 3 seconds.

COMMON SCREEN FUNCTIONS

Touch **X** to return to previous screen.

Touch **SAVE** in any screen displayed to save edited value & return to previous screen.



Use **◀** and **▶** arrows to move cursor under digit to be edited.

Use **▲** and **▼** arrows to set digit value.

Touch **GO** to enter code.

(The Default Code is 0000.)

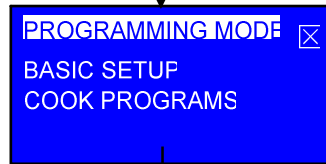

Touch **BASIC SETUP**

Touch to toggle **TEMP UNITS** between **F** and **C**

Touch to toggle **SIGNAL MODE** between **S**hort and **L**ong beeps.

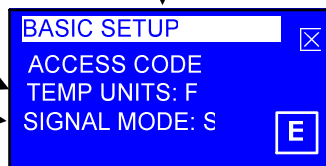

Touch **ACCESS CODE** to edit the user Access Code. (only if you want to set code to lock programming)

Touch to toggle language between **E**nglish and **S**panish.

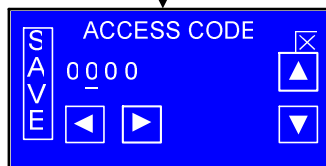

Use **◀** and **▶** arrows to move cursor under digit to be edited.

Use **▲** and **▼** arrows to set digit value.

(only if you want to set code to lock programming. The Default Code is 0000.)

Cook Recipe Editing

Start the controller and follow the procedure below to Edit a Cook Recipe.

COMMON SCREEN FUNCTIONS
 Touch  to return to previous screen.
 Touch **SAVE** in any screen displayed to save edited value & return to previous screen.

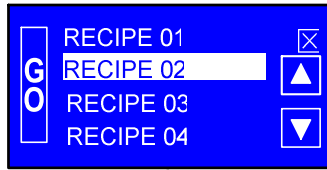

Touch highlighted Recipe for 3 seconds.

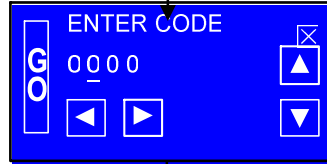

Use ◀ and ▶ arrows to move cursor under digit to be edited.

Use ▲ and ▼ arrows to set digit value.

Touch **GO** to enter code.

(The Default Code is 0000.)

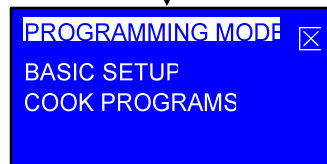

Touch **COOK PROGRAMS**.

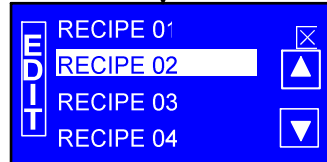

Use ▲ and ▼ arrows to highlight desired Recipe.

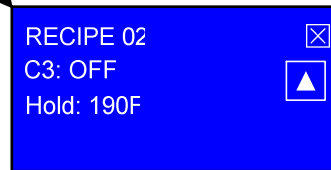
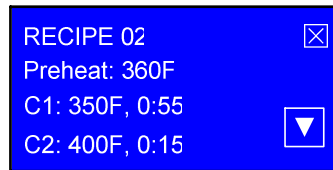

Touch **EDIT** to select highlighted Recipe.

Use ▲ and ▼ arrows to toggle between screens.

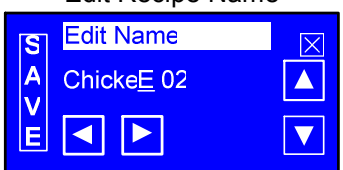

Touch any parameter to edit its value.

Touching a cook segment displays the Edit Cook Segment screen below.

<p>Edit Recipe Name</p>  <p>Use ◀ and ▶ arrows to move cursor under digit to be edited. Use ▲ and ▼ arrows to set digit value. Recipe names can be maximum of 13 digits including spaces. Values available in order of display - upper case alphabet, lower case alphabet, numbers 0 thru 9 & blank space.</p>	<p>Edit Preheat & Hold Temps</p>  <p>Use ◀ and ▶ arrows to move cursor under digit to be edited. Use ▲ and ▼ arrows to set digit value. To turn Preheat or Hold OFF – set temperature below 150F.</p>	<p>Edit Cook Segment</p>  <p>Touch any parameter on this screen to edit its value. Ck Temp is the segment oven temp. Time is for the individual segment. Ct Temp is cook to temp when core temp probe used. Cook segment parameter values are edited as shown for the Preheat Temp at left. To turn a cook segment OFF, set its Ck Temp below 150 F. To turn cook to temp OFF, set the Ct Temp below 150 F.</p>
---	---	--

Cooking

Start the controller and follow the procedure below to Cook with a programmed Recipe.

COMMON SCREEN FUNCTIONS



Touching  for 3 seconds on any screen cancels the cook cycle & returns to the Recipe List.

Touching  on any screen displays the actual oven temperature for 3 seconds.

The small inverse **H** to the right of the temperature is displayed when the heating elements are energized.

Touching **Extra** in any screen displayed activates the Extra Cook screen to add extra time to the programmed cook time.



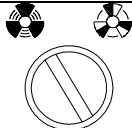

Use  and  arrows to adjust Extra Cook value in 5 minute increments.

Touch **GO** to add Extra time & return to previous Recipe screen.



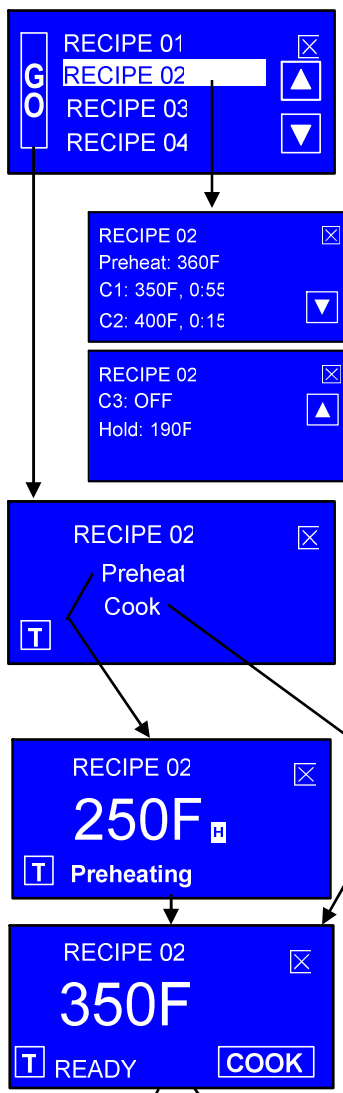

Fan Speed is manually controlled with a switch on control panel below touch screen controller.



Use  and  arrows to highlight desired Recipe.

Touch highlighted Recipe to preview its setting.

Touch **GO** to start highlighted Recipe.

Use  and  arrows to toggle between screens.

Touch  in either screen to return to Recipe List.

Touch **Preheat** to start heating the oven to the programmed temperature.

Touch **Cook** to go directly to the Cook Start screen.

(Preheating the oven before cooking is highly recommended.)

While oven is Preheating - screen displays programmed Preheat temperature.

Screen displays when the oven is preheated. Load product in the oven, close the door and touch **COOK** to start cooking.

Single Segment Recipe

Multi-Segment Recipe

Progress bar displays percentage of total Recipe time completed. Time displayed is total remaining Recipe time.



Progress bar is divided into number of Recipe segments & displays percentage of total Recipe time completed. Time displayed is total remaining Recipe time.

End of Cook Cycle without Hold

The controller will beep and the screen will flash until the screen is touched. The display shows the Time elapsed since the end of the Cook Cycle (no temperature is displayed).

Add Extra Cook time if required or touch  for 3 seconds to return to the Recipe List.

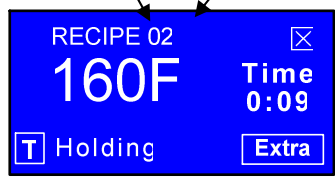

End of Cook Cycle with Hold

The controller will emit three 2 second beeps. The display shows programmed Hold Temperature and the Time elapsed since the end of the Cook Cycle.

Add Extra Cook time if required or touch  for 3 seconds to return to the Recipe List.

CP0058 Color TOUCH Tec Controller Operation

Features

The Color TOUCH Tec Controller has the following configurable features that will need to be properly set when installing a replacement controller. These settings can be entered individually through the configuration screens on the controller or downloaded from a USB drive.

Temperature Display Units are configurable for Fahrenheit or Celsius.

Operation Language is configurable for English or Spanish.

Audible Alarm Pattern is configurable for Short or Long patterns. This function is helpful to distinguish between controllers when two controllers are used on the same appliance.

View Recipe is configurable ON or OFF. When ON, a button is displayed on the Cook Recipe screen that will allow the user to view the settings of the highlighted Recipe.

Power Monitor calculates the energy consumption of the appliance over the elapsed time displayed. This function can be reset to zero by the user. The energy consumption values for this appliance's components must be entered into the controller.

USB Drive can be used to upload or download controller configurations and recipes.

Intuitive Cook Factor is configurable for OFF or values 5-15 in 0.5 increments. If Intuitive Cook is enabled the Factor determines the amount of cook time compensation.

Control Hysteresis is configurable from 1°F to 10°F by 1°F increments. Hysteresis is the differential between the temperature the controller turns the heaters off and the temperature it turns the heaters on again.

Extra Time increment value is configurable to 1 minute or 5 minutes.

Cook Temperature Offset is configurable between -50°F and +50°F in 1°F increments. The actual oven cavity temperature will vary from the programmed temperature by this offset amount.

Door Open Alarm is configurable ON or OFF. When ON, the controller alarms if the oven cavity temperature drops 25°F indicating the door has been left open.

Adjustable Idle Shutdown is configurable for OFF or 10, 20 or 30 minute delay. When enabled, this function will shut the oven off if it has been preheated and cook is not initiated before the preset time interval has elapsed.

(2) RTD Temperature Probe Inputs configurable to OFF or to monitor oven Cook Temperature or internal Product Temperature. One input must be configured to monitor oven Cook Temperature. Use of the internal Product Temperature probe is optional.

(2) Remote Switch Inputs configurable to OFF or to End cycle or add Extra Time when a momentary switch input is received. Both inputs can be configured OFF.

(2) Relay & (1) Solid State Outputs configurable to OFF or for Heat, Fan Power, Lamp or Fan Speed control.

Basic Setup Editing

Turn appliance power on and follow the procedure below to Edit the Basic Setup.

Press the three regions shown in green on the Cook recipe screen in sequence -

Lower left, lower right, and then upper left.

Maximum of two seconds between touches, valid touches emit a beep.

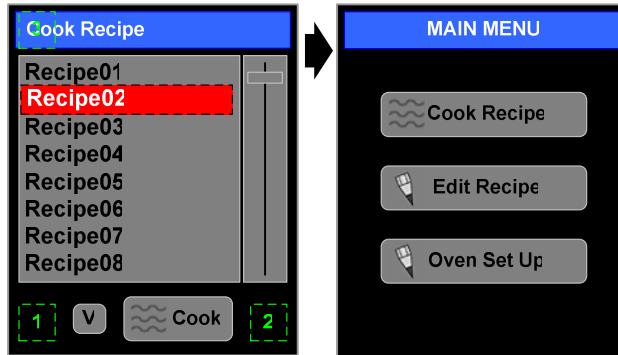

Touch **Oven Set Up**.

Touch **X** in any screen displayed to return to the previous screen.

Change Code – (to change current access code) opens numeric keypad window. Enter new access code and touch **OK**.

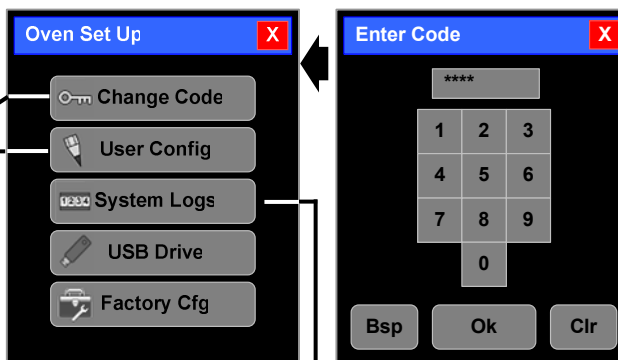

Use numeric pad to enter 4 digit access code. Touch **OK** to enter code.

Touch **Bsp** to backspace over last digit on entry line.

Touch **Clr** to clear entry line. (The Default Code is 9999.)

USB Drive & Factory Cfg on following pages.

Touch **T** beside parameter.

Beep: toggles between **Short** & **Long** beep patterns for end of cook cycle.

Units: toggles temperature between **deg Fahrenheit** & **deg Celsius**.

Lang: toggles language between **English** & **Spanish**.

View: toggles View Recipe button on Cook Recipe screen **ON** or **OFF**.

Touch to **SAVE** settings.

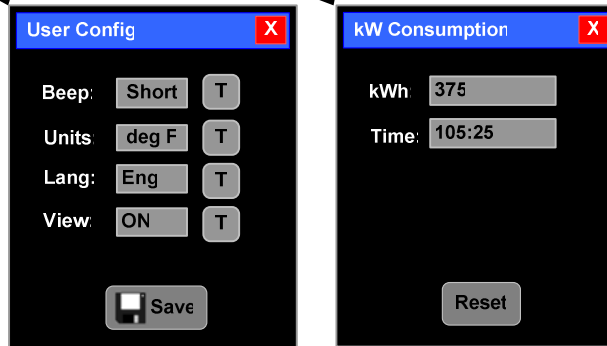

Displays kiloWatt hours of energy consumed by the appliance over elapsed Time displayed.

Touch to **RESET** display to zero.

USB Drive Usage

Remove the appliance side panel & insert USB Drive into the port on the bottom of the Controller.

Enter Oven Set Up screen as described on previous page.

Touch **X** in any screen displayed to return to the previous screen.

Touch **USB Drive**.

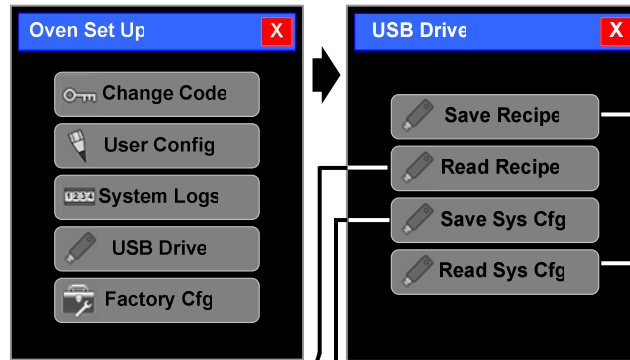

Read a Recipe from the USB Drive:

Highlight the Recipe to be read from the USB Drive to the controller and touch **READ**.

When the download is complete and the screen displays Data Read!, touch **Ok**.



Save a Recipe to the USB Drive:

Highlight the Recipe to be saved to the USB Drive and touch **SAVE**.

When the upload is complete and the screen displays Data Saved!, touch **Ok**.



Highlight the existing Recipe to be replaced by the Recipe saved from the USB Drive and touch **SAVE**.

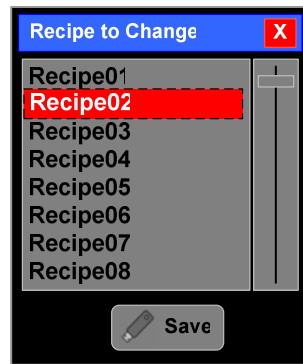

Read a Factory Controller Configuration from the USB Drive:

Highlight the Configuration to be read from the USB Drive to the controller and touch **READ**.

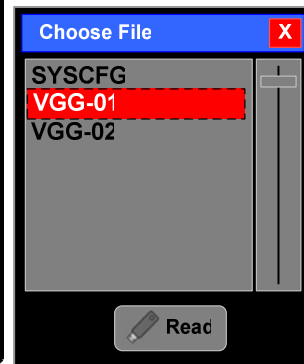

Save the Factory Controller Configuration to the USB Drive:

File name will be SYSCFG.BCF. *Do Not change file extension.*

When the upload is complete and the screen displays Data Saved!, touch **Ok**.



When the download is complete and the screen displays Data Read!, touch **Ok**.

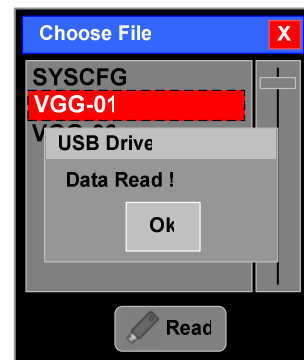

Controller Configuration

Configure the Controller inputs and outputs for this appliance.

Enter Oven Set Up screen as described previously.

Touch **X** in any screen displayed to return to the previous screen.

Touch **Factory Cfg.**

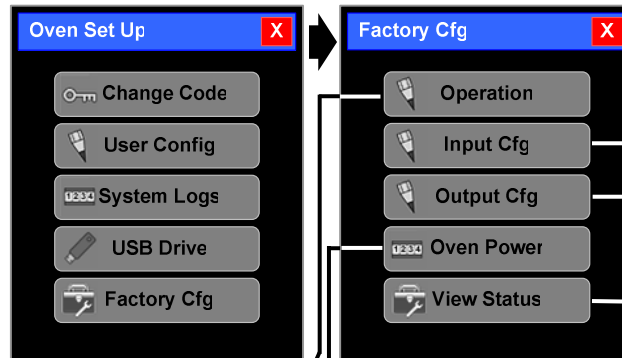

Hyst: change control hysteresis from 1F to 10F in 1F increments.

Ex T: toggles extra time increments between 1 min. and 5 min.

T Off: adjusts cook temperature offset between -50F & +50F in 1F increments.

D Alm: toggles 25F door alarm ON or OFF.

Pre T: adjust idle shutdown time from OFF to 10, 20 or 30 min.

SmCk: adjust intuitive cook factor from OFF to values 5-15 in 0.5 increments.

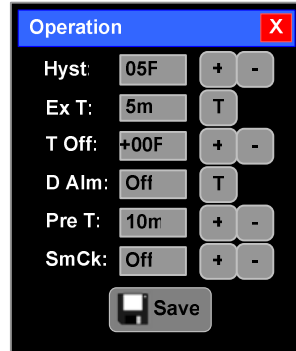

Touch **T** beside parameter.

P1 & P2 toggle between OFF, Cook & Product temperature.

S1 & S2 toggle between OFF, End & Extra Time.

Touch to **SAVE** settings.

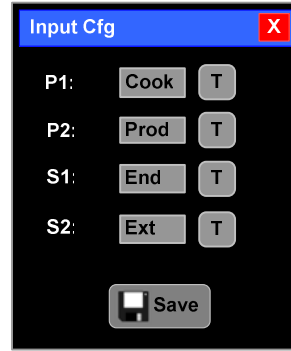

Touch **T** beside parameter.

R1, R2 & D1 toggle between OFF, Heat, Fan Power, Lamp & Fan Speed.

V1 toggles between OFF & Fan Speed.

Touch to **SAVE** settings.

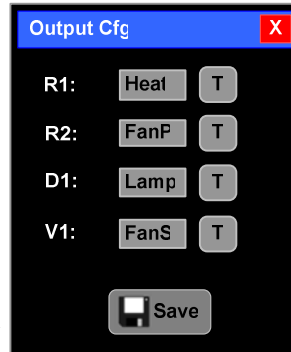

Touch **E** beside parameter to open a numeric window to enter parameter value.

Idle: idle power consumption.

Heat: heater power consumption.

Fan: fan power consumption.

Touch to **SAVE** settings.

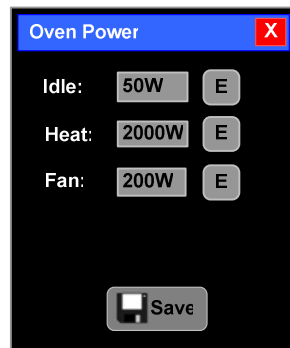

CK: measured Cook probe temperature.

PR: measured Product probe temperature.

End: state of End switch.

Ext: state of Extra switch. (OP=open, CL=closed)

Heat: toggles Heat output ON & OFF.

Lmp: toggles Lamp output ON & OFF.

FanP: toggles Fan output ON & OFF.

V1.10: software version (value may differ).

FanS: toggles Fan Speed between HI & LO.

Time: elapsed running time of controller.

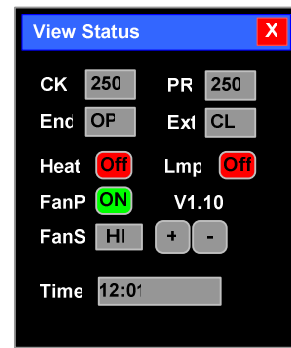

Recipe Editing

Follow the procedure below to Edit the Cook Recipes.

Enter the Main Menu screen as described on previously.

Touch **X** in any screen displayed to return to the previous screen.

Touch **Edit Recipe**.

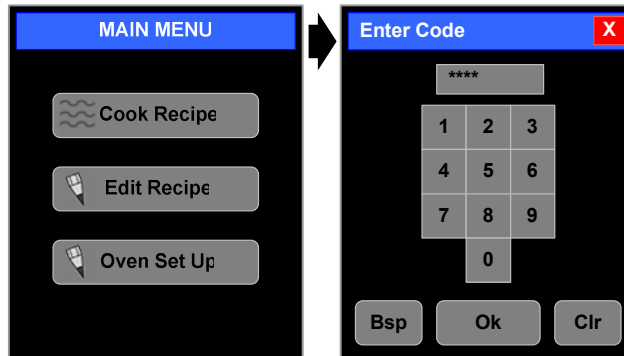

Use numeric pad to enter 4 digit access code. Touch **OK** to enter code.

Touch **Bsp** to backspace over last digit on entry line. Touch **Clr** to clear entry line.

(The Default Code is 9999.)

Touch Recipe line to edit.

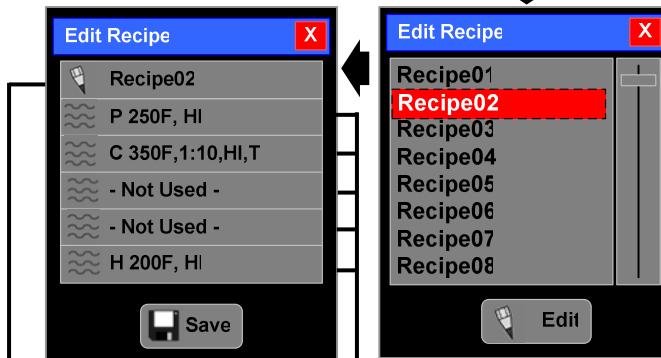

Select a Recipe by touching the Recipe name or moving the slider bar up and down.

When desired Recipe is highlighted, touch **Edit**.

Use keypad to enter Recipe name.

Sh toggles between upper & lower case.

Touch **Bsp** to backspace over last digit on entry line.

Touch **Clr** to clear entry line.

Touch to **SAVE** settings.

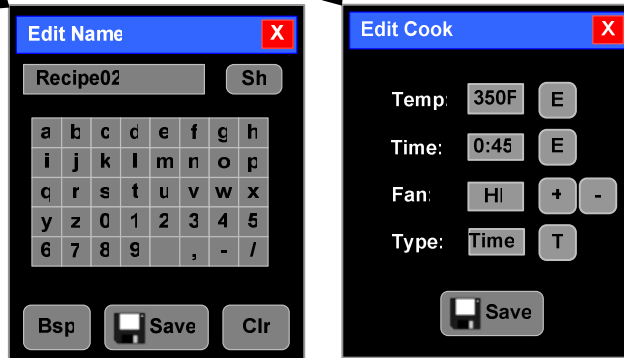

Temp: opens numeric keypad to set segment temperature. Set Hold Temp to 0 for no heat in Hold.

Time: opens numeric keypad to set segment time in format X:XX. Set to 0:00 to disable a Cook segment. (Available in cook segments only.)

Fan: toggles Fan Speed between HI & LO.

Type: toggles between Time and Smrt (intuitive cooking). All cook segments are changed to selected type. (Not available in Preheat & Hold segments.)

Cooking

Follow the procedure below to Cook with a programmed Recipe.

Touch **X** in any screen displayed to return to the previous screen.

Select a Recipe by touching the Recipe name or moving the slider bar up and down.

When desired Recipe is highlighted - touch **Cook** to start cook or touch **V** to View Recipe (if View Recipe is enabled).

View Recipe

Preheat @ 250F, HI fan speed.

Cook @ 350F for 1 hour 10 minutes, HI fan speed, by Temperature (T changes to S with intuitive cook enabled).

Hold @ 250F, HI fan speed.

Display Temperature

Displays actual oven cavity temperature.

If Cook to Internal Temperature is enabled, touch **Cook Temp** title bar to change display to actual product core temperature.

Touch **X** to return to the Recipe screen.

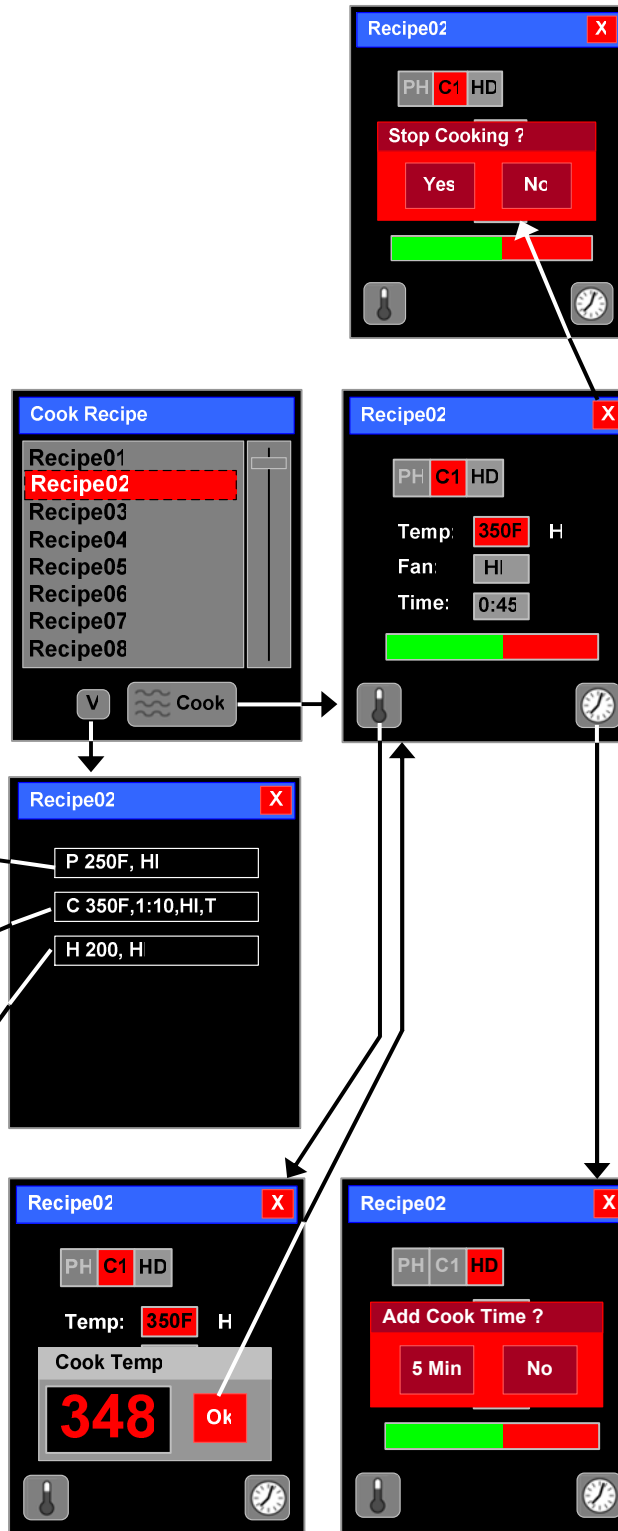

Touch **X** in Recipe screen to cancel Cooking Recipe.
 Touch **Yes** to confirm cancellation and return to The Cook Recipe Screen
 Touch **No** to continue Cooking Recipe.

Recipe Segments & Status - Completed, Current, Future
 PH=Preheat; C1,C2 & C3= Cook Segment; HD = Hold (C2 & C3 only shown when enabled.)

Temp: programmed segment temperature.

H displayed when heaters are energized. If Hold temperature is 0, **Off** is displayed in Hold mode.

Fan: segment fan speed setting.

Time: remaining in segment.

Progress Bar – green displays the percentage of segment time elapsed. In Preheat, displays approach to set point from room temperature.

Add Cook Time

Only available in Hold mode.

Touch **No** to cancel Add Cook Time function.

Each touch of **5 Min** adds one 5 minute increment of Cook Time.

When Cook Time is added, **No** changes to **Done**. Touch **Done** to start extra time cook.

Cooking Suggestions

Most recipes can be adjusted for convection oven use by decreasing the temperature by 25° F and decreasing cooking time about 25%. Dishes with cooking times over 45 minutes and that might dry out too much (like lasagna, or meatloaf) should be covered for the first half of the cooking time.

Installation

⚠ WARNING

Serious injury, equipment damage or death could result if attempting to install this oven yourself. Ensure that an authorized BKI service agent install the oven.

Unpacking and Handling

It is the owners' responsibility to file all freight claims with the delivering truck line. Inspect all cartons and crates for damage as soon as they arrive. If damage to cartons or crates is found, or if a shortage is found, note this on the bill of lading (all copies) prior to signing.

If damage is found when the equipment is opened, immediately call the delivering truck line and follow up the call with a written report indicating concealed damage to your shipment. Ask for an immediate inspection of your concealed damage item. Packaging material **MUST** be retained to show the inspector from the truck line.

Remove all packing from the interior and exterior of the oven.

Location and Clearance

The oven must be mounted on a level surface capable of supporting the fully loaded oven. Refer to Chart 1 for oven weight.

Adequate clearance must be provided around the oven for safety, proper operation and ventilation. Refer to Chart 1 for required minimum clearances. Note that these are minimum clearances. If the oven is to be permanently mounted near other immovable objects additional clearance must be provided for connection and service of the oven on both sides.

All ventilation slots must be kept free from obstruction.

Extraction

Extraction is not a specific requirement for this type of appliance. Certain conditions, e.g./ installation in a confined space, temperature controlled environment, continuous use or high volume production cooking may require the need for extra ventilation or extraction. Consult your local ventilation/extraction air conditioning company.

Wiring

⚠ WARNING

Electrocution, equipment failure or property damage could result if an unlicensed electrician performs the electrical installation. Ensure that a licensed electrician perform the electrical installation.

⚠ DANGER

Failure to restrain the oven when permanently connected could allow it to move, possibly resulting in electrical shock.

Attach an ANSI Z21.69A compliant restraining device (such as BKI part number [FT0279](#)) according to the instructions provided by the restraining device manufacturer in the location shown at right.

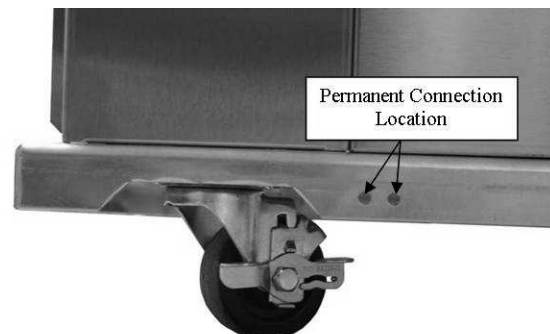
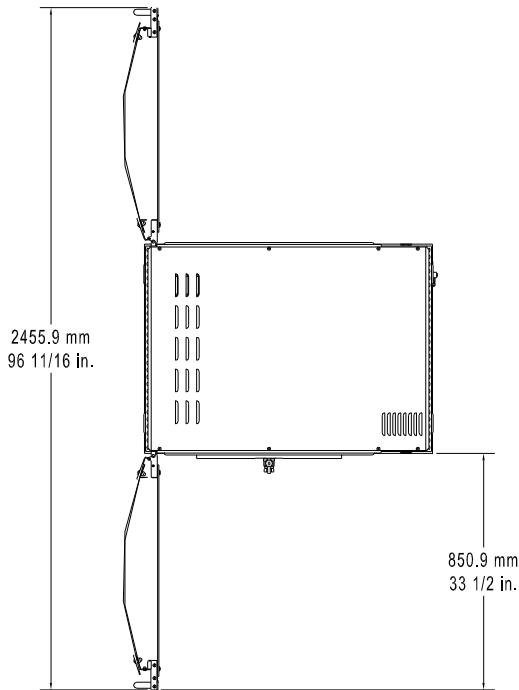

Chart 1. Location and Clearance



Electrical Specifications (North America)

3Ph + Gnd, 60Hz

Volts	Amps	KW	Breaker
208	28.5*	10.2*	40*
220	24.8*	9.3*	35*
240	27.0*	11.1*	35*

* Ratings COq oven cavity. VGG/COq requires a separate power supply for each oven cavity.

Electrical Specifications (Europe)

230/400 Volts, 3Ph + Gnd + E, 50Hz

Model	Amps	Watts
L1	15.1	3482
L2	14.7	3400
L3	14.3	3300

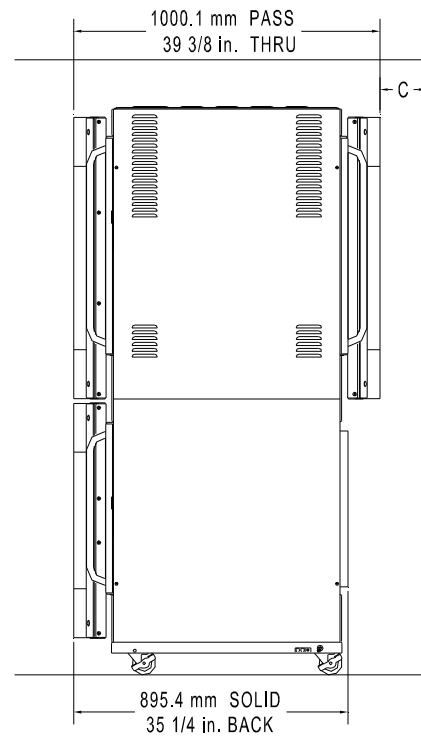
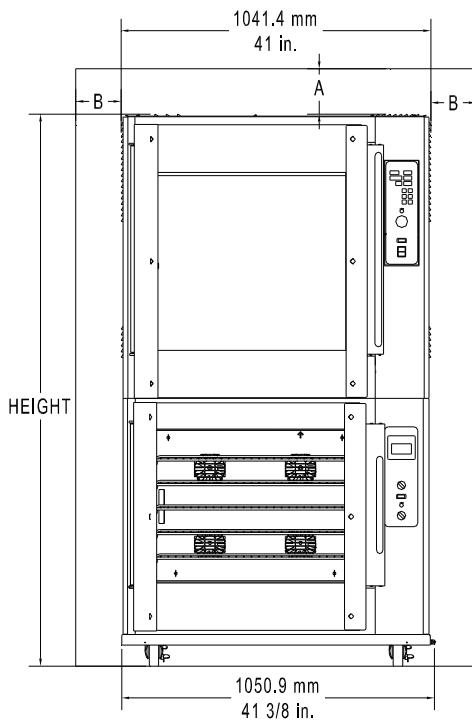

Model	Height	Shipping Weight	Minimum Clearance					
			Combustible Surface			Non-Combustible Surface		
			A	B	C	A	B	C
COq	850.9 mm	259 KG	152.5 mm	152.5 mm	152.5 mm	51.0 mm	51.0 mm	51.0 mm
	33 1/2 in.	570 lb.	6 in.	6 in.	6 in.	2 in.	2 in.	2 in.
VGG/COq	1855.8 mm	453 KG	152.5 mm	152.5 mm	152.5 mm	51.0 mm	51.0 mm	51.0 mm
	73 1/16 in.	1000 lb.	6 in.	6 in.	6 in.	2 in.	2 in.	2 in.

General Guidelines

- In the absence of local codes refer to the latest edition of one of the following:
 - National Electrical Code, ANSI/NFPA 70-20XX (USA) which can be obtained from:

The National Fire Protection Association
Batterymarch Park
Quincy, MA 02269

- I.E.E. Wiring Regulations (Europe)
- Verify that the power supply conforms to the electrical rating listed on the oven data plate.
- Ensure that the appliance is grounded (earthed).

Guidelines for European Appliances

Note: - A method of disconnection from the main supply having a contact separation of least 3mm in all poles must be incorporated in the fixed wiring.

- It is recommended that an **R.C.D.** with a 30ma trip and contact rating to suit the appliance current be installed adjacent to the appliance.
- Type C/ 3 circuit breakers or appropriate rated fuses are recommended for installation at the supply end.

Note: - surge currents are present when this appliance is switched on from cold.

- Industrial plugs and sockets must comply with BS 4343/EN60309 (IEC309.2/CEE17).

Supply Cable Connection

- It is recommended that the power supply cable shall be an oil resistance sheathed flexible cable to BS 6007 (code designation HO7 RN-F).
- It is required that the power supply cable connection to the appliance terminal block, the earth conductor is to be made at least 50mm longer than the length of the live (L) and neutral (N) conductors so that if the supply cable is strained the earth conductor is the last to become disconnected.
- To gain access to the control panel and mains block connection, remove the 4-side panel securing screws on the drive side of the oven.
- The mains block is sited toward the bottom right hand side of the control box. Cable entry is provided through the base of the oven.
- Refer to the mains wiring diagram for correct connection.

Operating

Please read the operating instructions thoroughly and ensure all packaging has been removed before switching main power 'On'.

IMPORTANT: Ensure that whoever is operating this appliance is fully conversant with its working and is made aware of the dangers of incorrect operation.

Safety Cut-Out

For added safety all COq ovens have a built in thermal cut-out to protect against over-heating through component failure or incorrect use. If for any reason the thermal cut-out operates, the oven will automatically shut down and should be switched 'Off', disconnected from the mains and allowed to cool.

NOTE: - The thermal cut-out will not re-set automatically.
The oven must not be re-used until a qualified electrician or BKI service agent has checked it.

Maintenance

⚠ CAUTION

Failure to comply with the maintenance below could result in a serious accident or equipment damage.

⚠ DANGER

Failure to remove power from this unit before performing maintenance may cause severe electrical shock. This unit may have more than one disconnect switch.

Scheduled Maintenance

Oven Cleaning (Daily)

Cleaning is not only necessary for sanitary reasons, but will increase sales appeal and maximize operating efficiency.

⚠ DANGER

Failure to remove power from this unit may cause severe electrical shock. This unit may have more than one disconnect switch.

⚠ CAUTION

Using abrasive cleaners may damage the oven finish. Use only a mild soap and water solution.

Never steam clean or get excess water in the interior of the oven as this can damage unit. This appliance is not designed for use with a water jet.

DO NOT USE OVEN CLEANER on this machine. Caustic cleaners can cause damage to the machine.

Always wear appropriate personal protection equipment during the cleaning process to guard against possible injury from hot cleaning solution.

1. Allow oven to cool below **50° C (120° F)**.
2. Turn the Main Power Switch off and disconnect from the Main Power Isolator (Circuit Breaker).
3. On oven so equipped, empty the grease drawer using the drain valve or fat pump.
4. Remove all food products from the unit.
5. Remove oven racks by lifting up on the front and pulling the racks out of the oven. Remove the rack side supports by lifting them up and away from the sides of the oven cavity. Remove drip tray (if so equipped).
6. Remove the fan cover in the back of the oven cavity by
 - a. removing the (2) retaining nut in the center of the fan cover
 - or
 - b. Unlatch the ¼ turn fasteners on each corner of the cover by turning them counterclockwise then pull the fan cover straight out of the oven cavity.

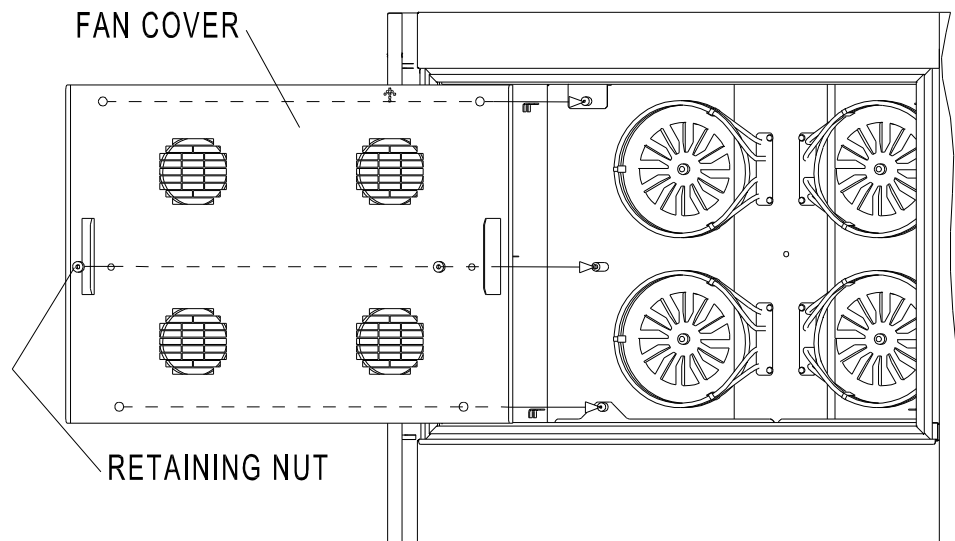

7. Place all of the components removed in a large sink to soak in hot cleaning solution. Then clean the components with warm water, a sponge and **BKI** Cleaner. Wipe dry with a clean cloth.
8. Clean the inside of the oven cavity with warm water, a sponge and **BKI** Cleaner. Wipe dry with a clean cloth.
9. Carefully clean the fan blades in the back of the oven with warm water, a sponge and **BKI** Cleaner. Be careful not to bend the blades.
10. Clean the outside of the oven with warm water, a sponge and **BKI** Cleaner. Wipe the unit dry with a soft cloth.
11. Reassemble the oven.

Troubleshooting

Refer to the table below for troubleshooting information.

Problem	Indication	Cause	Possible Solution
Main Power Switch On does not start oven, the control screen does not energize.	Main Power Indicator Light is not lit.	Appliance circuit breaker (isolator) is turned off or tripped.	Call qualified electrician. Verify power supply to panel & reset breaker (isolator).
	Main Power Indicator Light is not lit.	Controller Fuse is blown.	Call BKI service technician. Identify & resolve cause of blown fuse, replace fuse.
		High Limit Thermostat tripped or defective.	Call BKI service technician. Tripped - identify & resolve cause. Defective - replace thermostat.
		Defective R1 Relay.	Call BKI service technician. Replace relay.
None of the lights illuminate when controller screen is touched to activate oven.		Light circuit Fuse is blown.	Call BKI service technician. Identify & resolve cause of blown fuse, replace fuse.
Not all lights illuminate when controller screen is touched to activate oven.		Failed Light Bulb(s).	Call BKI service technician. Replace light bulb(s).
Fans & Heating Elements do not start when Preheat is touched on controller screen.		Inner Door not (completely) closed.	Close door, make certain magnetic latch on handle side of door contacts face of oven.
	Inner Door completely closed.	Failed Inner Door Magnetic Sensor.	Call BKI service technician. Replace magnetic sensor.
	With Optional Dripping Drawer & Fan Cover Switches.	Dripping Drawer not (completely) installed, Fan Cover not (properly) installed.	Push dripping drawer fully into oven, verify Fan Cover retainers are fully tightened.
	Inner Door is closed and Dripping Drawer & Fan Cover properly installed.	Failed Inner Door Magnetic Sensor.	Call BKI service technician. Troubleshoot switches & sensor, replace failed component.
Failed Dripping Drawer Switch.			
Failed Fan Cover Switch.			
Fans start but Heating Elements do not heat when Preheat is touched on screen.		Failed R2 relay.	Call BKI service technician. Troubleshoot cause & replace defective component.
		Defective Controller output.	

Problem	Indication	Cause	Possible Solution
Heating Elements heat but Fans do not start when Preheat is touched on screen.	High Limit Thermostat will trip if condition goes undetected.	Failed R5 relay.	Call BKI service technician. Troubleshoot cause & replace defective component.
		Defective Controller output.	
Oven Preheats slowly or does not achieve preheat temperature		Failed Heating Element.	Call BKI service technician. Troubleshoot cause & replace defective component.
		Failed Fan Motor(s).	
		Blocked air ports in Temperature Probe.	
Fans & Heating Elements do not restart after oven is loaded & Cook is touched on screen.		Inner Door not (completely) closed.	Close door, make certain magnetic latch on handle side of door contacts face of oven.
	Inner Door completely closed.	Failed Inner Door Magnetic Sensor.	Call BKI service technician. Replace magnetic sensor.
Oven shuts down during Preheat or Cook cycle, Main Power Indicator is lit.		High Limit Thermostat(s) tripped.	Call BKI service technician. Identify & resolve cause of trip (failed fan motor), reset thermostat(s)
Product not done at end of cook cycle, poor product color.		Failed Heating Element.	Call BKI service technician. Troubleshoot cause & replace defective component.
		Failed Fan Motor(s).	
		Failed Relay (R2, R4 or R5).	
Product overcooked at end of cook cycle, dark product color.		Blocked air ports in Temperature Probe.	Call BKI service technician. Replace defective component.
Fan Motor(s) stop during Preheat or Cook cycles.		Ventilation slots in back obstructed.	Clear obstruction(s).
		Cooling Fan(s) failed.	Call BKI service technician. Replace cooling fan(s).

Component Replacement

Light Bulb

1. Disconnect the oven power supply by turning OFF the circuit breaker in the power supply service panel.
2. Remove appropriate side panel from oven.
3. Identify lampholder with failed light bulb.
4. Loosen but do not remove the lampholder mounting screw closest to the center frame of the oven. While holding the lampholder remove the other mounting screw.
5. Move the lampholder to the side away from the remaining mounting screw then pull the lampholder away from the oven.
6. Unscrew the failed light bulb from inside of the lampholder and replace with a new bulb.
7. Reinstall the lampholder on oven then replace side panel.
8. Turn the power supply to the oven ON.

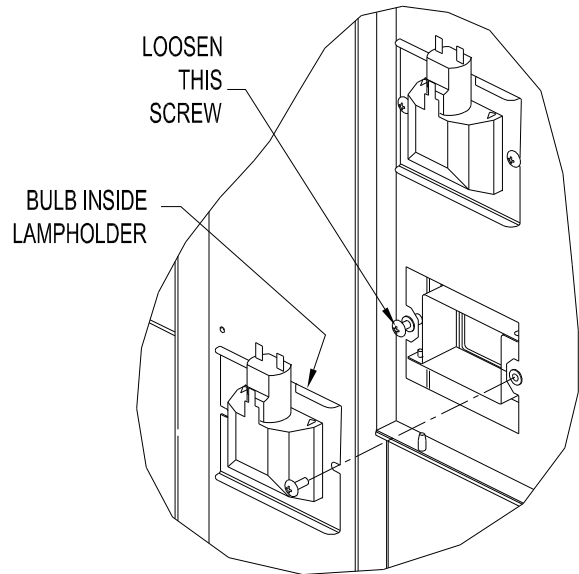

Fuse Replacement

1. Disconnect the oven power supply by turning OFF the circuit breaker in the power supply service panel.
2. Remove the side panel from the control side of the oven.
3. Remove the fuse from the fuseholder by inserting a 1/8" [3 mm] flat screwdriver into the slot in the fuseholder cap. While pushing in turn the screwdriver approximately 1/4 turn counterclockwise. Remove the screwdriver. The fuse and cap can be pulled out of the fuseholder.
4. Check the fuse for continuity with an Ohm meter.
5. If the fuse is blown, locate and correct the cause of the fuse failure before replacing the fuse.
6. Replace blown fuse with the factory specified fuse only. Contact the BKI Technical Service Department for the correct fuse.
7. Reinstall the fuse in the fuseholder by reversing the procedure in step 2.
8. Reattach the side panel to the oven and turn the power supply to the oven ON.

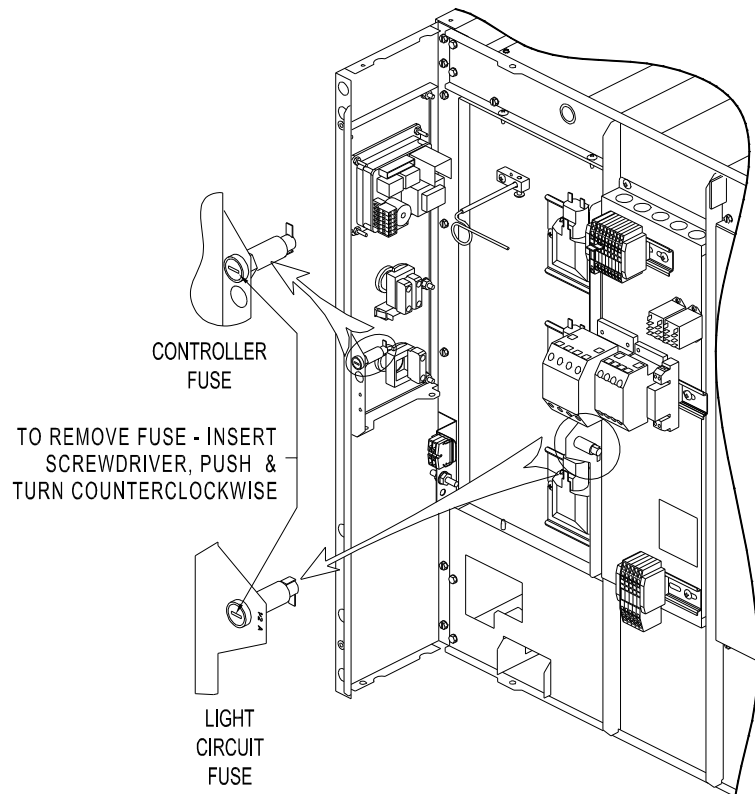

Temperature Probe

1. Disconnect the oven power supply by turning OFF the circuit breaker in the power supply service panel.
2. Remove the side panel from the control side of the oven.
3. Loosen probe clamp retaining screw and slide probe out of clamp.
4. Remove probe wires from the connector by inserting a 1/8" [3 mm] flat screwdriver into the release slots as shown. Insert wires from the replacement probe into the connector in the same manner. Probe is not polarized so it does not matter which color wire is inserted into the connector sections.
5. Insert the replacement probe into the clamp. The replacement probe must protrude into the cavity 5/8" [16 mm] as shown. Tighten the retaining screw. Neatly coil the excess lead length from the probe and tie wrap it so it does not contact other oven components.
6. Reattach the side panel to the oven and turn the power supply to the oven ON.

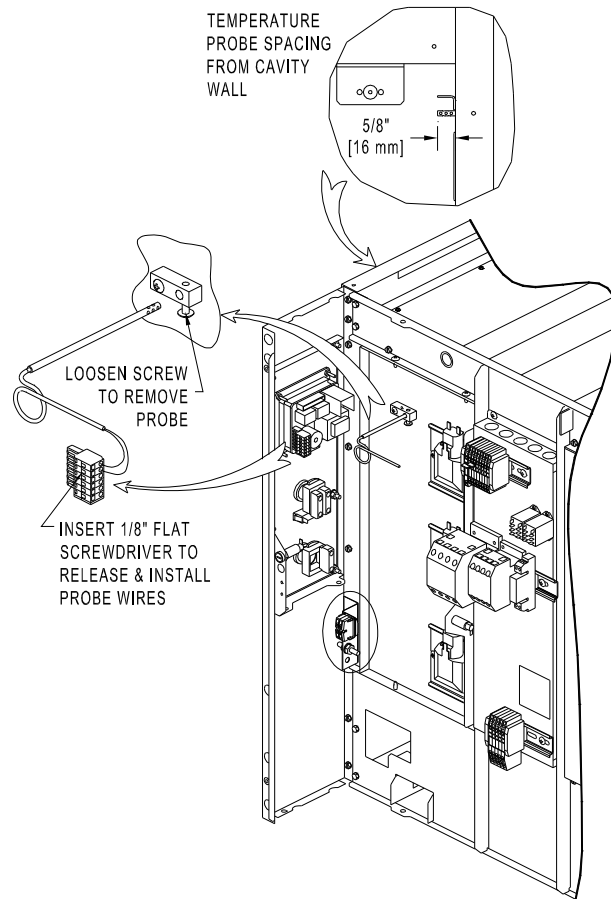

Pushbutton Switch Contact Blocks

1. Disconnect the oven power supply by turning OFF the circuit breaker in the power supply service panel.
2. Remove the side panel from the control side of the oven.
3. Release the contact block mount from the pushbutton operator by depressing the release cam.
4. Move the contact block(s) and mount to an accessible position. Loosen the terminal retaining screws and remove the wires from the contact block.
5. Remove contact block from mount by inserting a flat screwdriver into the retaining clip on one side of the contact block and prying up.
6. Snap replacement contact block into place on the mount. Connect wires to replacement contact block.
7. Slide contact block mount back into position on the pushbutton operator. Push the contact block mount in until it snaps into place.
8. Reattach the side panel to the oven and turn the power supply to the oven ON.

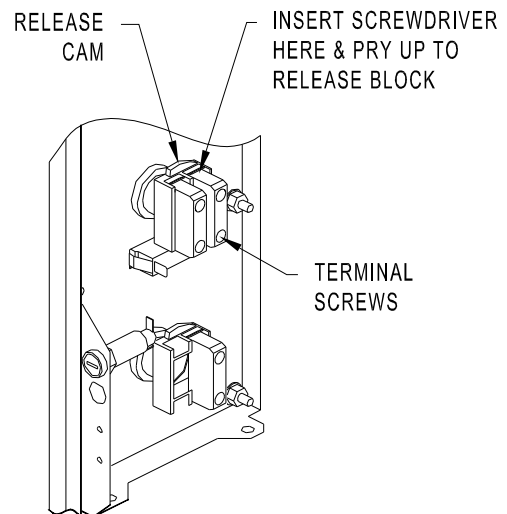

Contactors

1. Disconnect the oven power supply by turning OFF the circuit breaker in the power supply service panel.
2. Remove the side panel from the control side of the oven.
3. Loosen Contactor terminal screws and remove wires from Contactor. Record the Contactor wiring connections before removing the wires.
4. The Contactor is mounted on a rail attached to the control panel. A release tab is located on the bottom of the Contactor base. To remove the Contactor, insert a flat screwdriver into the release tab and pull the tab away from the Contactor. While the release is pulled out rock that side of the Contactor up then move it toward the control board and lift it out of the control panel.
5. Install the replacement Contactor in the same orientation as the original. Tilt the side of the Contactor with the release tab up slightly and position the Contactor over the mounting rail. Engage the low side of the Contactor base on the mounting rail then rock the high side down until the release tab snaps in place on the rail.
6. Attach the wires to the replacement Contactor. Be sure to tighten the terminal screws as specified on the Contactor.
7. Reattach the side panel to the oven and turn the power supply to the oven ON.

Controller

1. Disconnect the oven power supply by turning OFF the circuit breaker in the power supply service panel.
2. Remove the side panel from the control side of the oven.
3. Unplug connectors from the Controller by pulling straight out on the connector.
4. Remove the (4) retaining nuts using a 5/16" nut driver and remove the failed Controller.
5. Install the replacement Controller over mounting studs in the same orientation as the original. Reinstall and tighten the (4) retaining nuts.
6. **CP0046** CONTROLLER - Set dip switch on replacement Controller as shown at right.
7. Plug all connectors into replacement Controller.
8. Reattach the side panel to the oven and turn the power supply to the oven ON.
9. Turn oven On and configure replacement controller as required. Refer to the Operation section of this manual for instructions.

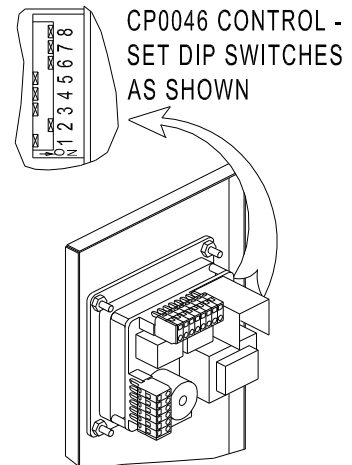

High Limit Thermostat

1. Disconnect the oven power supply by turning OFF the circuit breaker in the power supply service panel.
2. Remove the Back Panel and Fan Cover from the oven.
3. Remove the Clamp securing the excess capillary of the failed Thermostat on the back of the oven. Then remove the Nut from the Thermostat stem with a 12 mm wrench.
4. Loosen the Nut on the capillary retaining Screw from the outside of the oven. Place a piece of tape over the head of the capillary retaining Screw on the inside of the oven then remove the Nut from the outside. Remove the tape and capillary retaining Screw from inside of the oven.

5. Remove the (2) Screws securing the thermostat capillary bulb Mounts.
6. Carefully slide the capillary bulb out of the holes in the Mounts. Feed the Thermostat capillary and bulb through the large portion of the capillary keyhole in the back of the oven.
7. Mount the replacement Thermostat on the back of the oven with the nut provided. Orient replacement Thermostat in the same orientation as the original. Secure nut on Thermostat stem with 12 mm wrench.

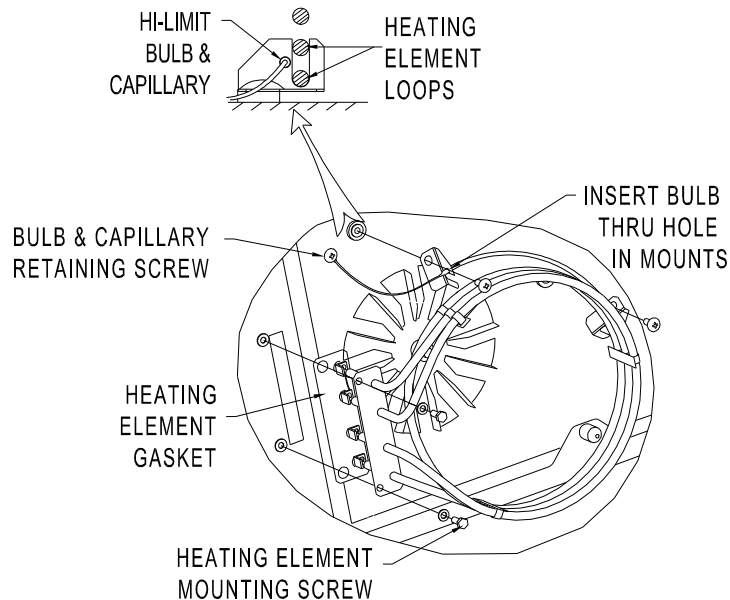

INSIDE OVEN CAVITY

8. Insert the bulb and capillary of the replacement Thermostat into the oven from the back through the large portion of the capillary keyhole in the oven back.
9. Insert the Thermostat bulb and capillary into the Mounts on the Heating Element. Be careful not to kink or pinch the capillary tube.
10. Secure the thermostat bulb Mounts to their standoffs with the two phillips Screws.

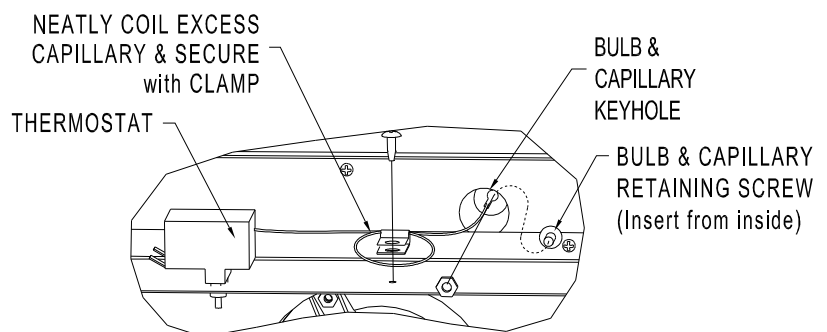

BACK of OVEN

11. Carefully slide the excess Thermostat capillary through the keyhole in the oven back. Move the capillary into the smaller portion of the keyhole and insert the retaining Screw into the larger portion.
12. Place a piece of tape over the head of the capillary retaining Screw inside of the oven. Thread the Nut onto the capillary retaining Screw from the back of the oven. Remove the tape from the head of the capillary retaining screw and tighten the Screw.
13. Carefully coil the excess capillary on the back of the oven and secure it with the Clamp and Screw. Do not bend the capillary in a radius smaller than 1/2" [12 mm].
14. Reattach the back panel and fan cover to the oven and turn the power supply to the oven ON.

Fan Blade

1. Disconnect the oven power supply by turning OFF the circuit breaker in the power supply service panel.
2. Remove the fan cover from the oven.
3. Loosen the set screw on the Fan Blade hub with a 1/8" hex wrench and pull Fan Blade off of Motor shaft.
4. Slide new Fan Blade onto Motor shaft. Space the back of the Fan Blade 1/4"-3/8" [6-9 mm] from back wall of cavity.
5. Orient set screw in Fan Blade hub over the flat on the Motor shaft and tighten set screw with 1/8" hex wrench.
6. Spin the Fan Blade by hand to make sure it is properly balanced on Motor shaft.
7. Reattach Fan Cover and turn the power supply to the oven ON.

Fan Motor

1. Disconnect the oven power supply by turning OFF the circuit breaker in the power supply service panel.
2. Remove the back panel and fan cover from the oven.
3. Remove the Fan Blade from the Motor as described above.
4. From the back of the oven, unplug the wiring connections to the Motor. Remove the (3) retaining nuts with an 11/32" hex driver. Pull Motor straight out from the back to remove it.
5. Install replacement Motor on back of oven over the mounting studs and secure with the (3) nuts.
6. Connect the wiring to the Motor as detailed in the diagram on the next page.
7. The orientation of the yellow and orange wires in the Motor connector establishes the direction of shaft rotation. Note orientation of yellow and orange wires in the Motor connector. Compare this orientation to the diagram on the next page. If necessary, unplug connector, rotate one side 180 degrees and plug the halves back together to achieve proper orientation.
8. Reattach the Fan Blade as described above.
9. Reattach the back panel and fan cover to the oven and turn the power supply to the oven ON.

Fan Cover Micro Switch

1. Disconnect the oven power supply by turning OFF the circuit breaker in the power supply service panel.
2. Remove the back panel from the oven.
3. Disconnect the wires from the Switch and remove Switch using a Phillips screwdriver and 1/4" wrench.
4. Install replacement Switch in the same orientation as the Switch that was removed.
5. Connect the wires to the COM and NO terminals of the Switch.
6. Verify that the Switch contacts change state when the Fan Cover is removed and installed. If necessary, bend the Switch actuator arm as required for proper operation.
7. Reattach the back panel to the oven and turn the power supply to the oven ON.

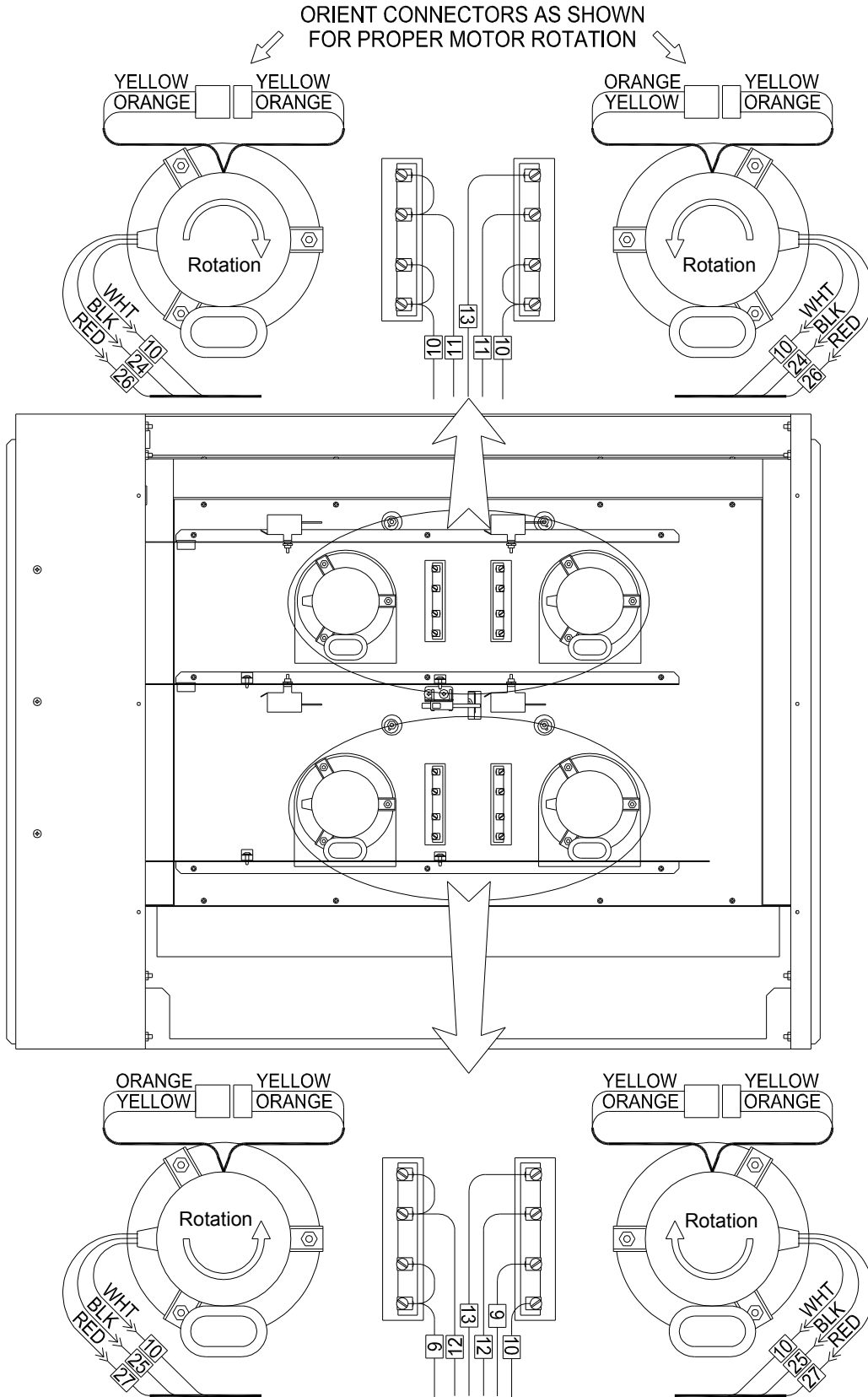

MOTOR & HEATING ELEMENT CONNECTION DIGRAM

Heating Elements

1. Disconnect the oven power supply by turning OFF the circuit breaker in the power supply service panel.
2. Remove the back panel and fan cover from the oven.
3. Disconnect the wires on the failed Heating Element from the back of the oven. Remove the (2) screws mounting the failed Heating Element from inside the oven.
4. Carefully pull the failed Heating Element away from the back of the oven.
5. Slide a new Gasket over the terminal ends of the Heating Element and set the replacement Heating Element in position in the oven.
6. Secure the Heating Element to the back of the oven with the two mounting screws.
7. Connect the wires to the replacement Heating Element from the back of the oven. Refer to the diagram on the previous page for proper connection.
8. Reattach the back panel and fan cover to the oven and turn the power supply to the oven ON.

Parts List

Use the information in this section to identify parts. To order parts, call your **BKI** sales and service representative. **Before calling, please note the model and serial numbers on the rating tag affixed to the unit.**

Description	Assembly #	Figure #	Table #
COq		Figure 1	Table 1
BASE PLATE - COq BASE PLATE - VGG/COq	AB55129800 AB55129700	Figure 2	Table 2
CONTROL PANEL – MANUAL FAN SPEED CONTROL PROGRAMMABLE FAN SPEED	AB30121000 AB30125700	Figure 3	Table 4
CONTROL PLATE - CP0046 CONTROLLER	AB30115200	Figure 4	Table 4
CONTROL PLATE - CP0058 CONTROLLER	AB30122300	Figure 5	Table 5
DRIPPING DRAWER w/ DRAIN DRIPPING DRAWER w/o DRAIN	AB55130300 WB30126200	Figure 6	Table 6
INNER DOOR	AB30115500	Figure 7	Table 7
OUTER DOOR (FLAT)	AB30127400	Figure 8	Table 8
OUTER DOOR – STANDARD HGHT. CURVED GLASS VGG-8 CURVED GLASS	AB30115600 AB30121500	Figure 9	Table 9

Figure 1. COq Parts

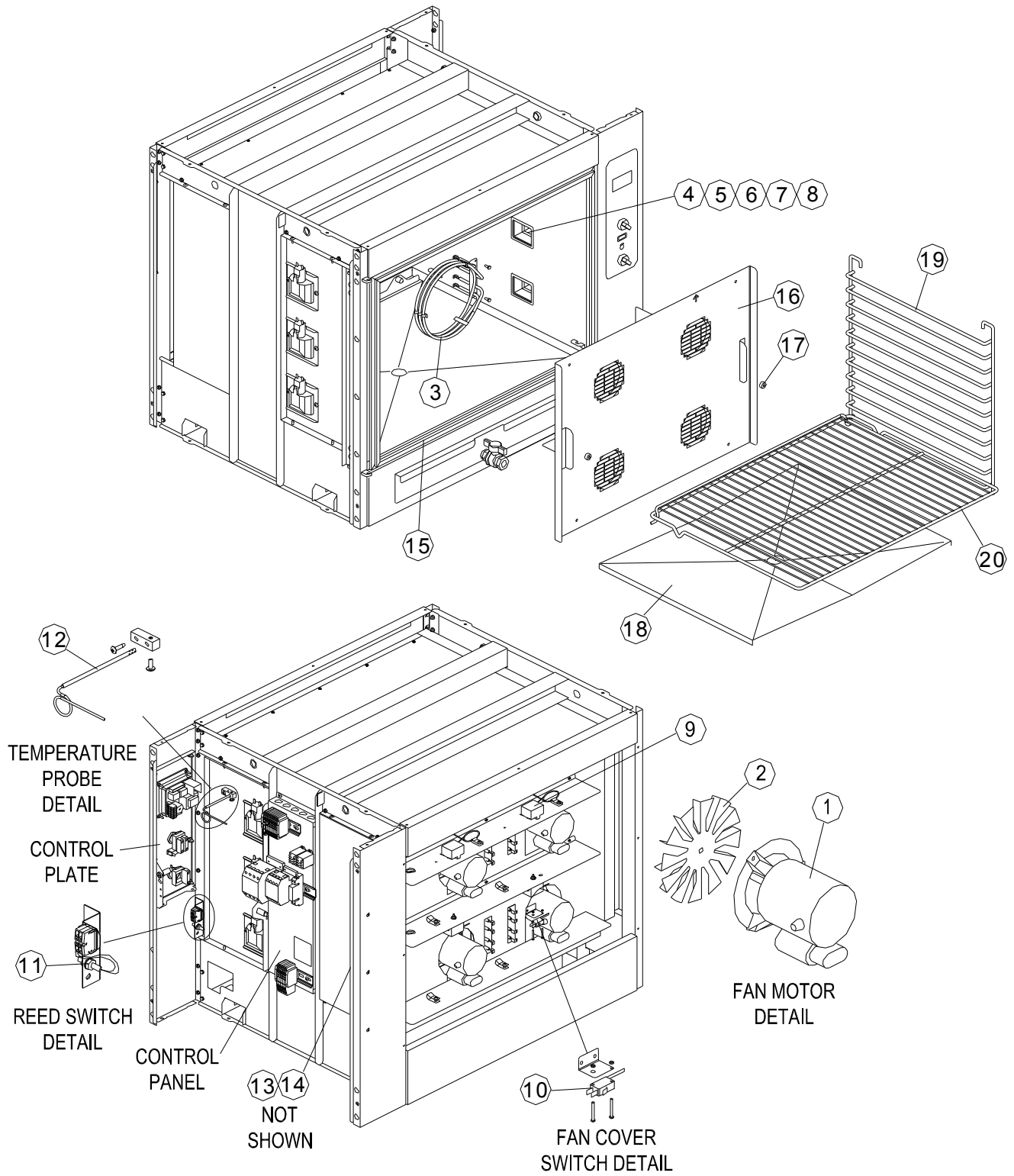

Table 1. COq Parts

ITEM #	PART #	QTY	DESCRIPTION
1	M0104 M0105 CP0010	4	BLOWER MOTOR, 230 V BLOWER MOTOR, 208 V CAPACITOR, 2 mfd
2	FN0037	4	FAN IMPELLER
3	C0156 C0154	4	HEATING ELEMENT, 208 V HEATING ELEMENT, 230 V
4	LI033UK	6	LAMPHOLDER BODY
5	LI034UK	6	GASKET, LENS
6	LI035UK	6	FRAME, LENS
7	LI038UK	6	LENS, LAMPHOLDER
8	LI037UK	6	REPLACEMENT BULB, 25 W, 230 V
9	T0105	4	THERMOSTAT, HIGH LIMIT
10	S0355	1	SWITCH, MICRO
11	S0363	1	SWITCH, MAGNETIC REED
12	T0170	1	TEMPERATURE PROBE, AIR
13	FN0012 CS0022	2	COOLING FAN CORDSET
14	SCR315	8	SCREW, #6-32 X 2"
15	G0119	1	GASKET, INNER DOOR SEAL
16	WB30126000 WB30120900	1	FAN COVER (AMERICA) FAN COVER (EUROPE)
17	L0116 & L0118 NU059UK	4 2	QTR. TURN LATCH (AMERICAS) NUT, M6 KNURLED (EUROPE)
18	FB30128203	2	DRIP TRAY (OVENS w/ DRAWERS ONLY)
19	R0031	2	SIDE SUPPORT, RACK
20	R0032	5	OVEN RACK, FULL SIZE

Figure 2. Base Plate

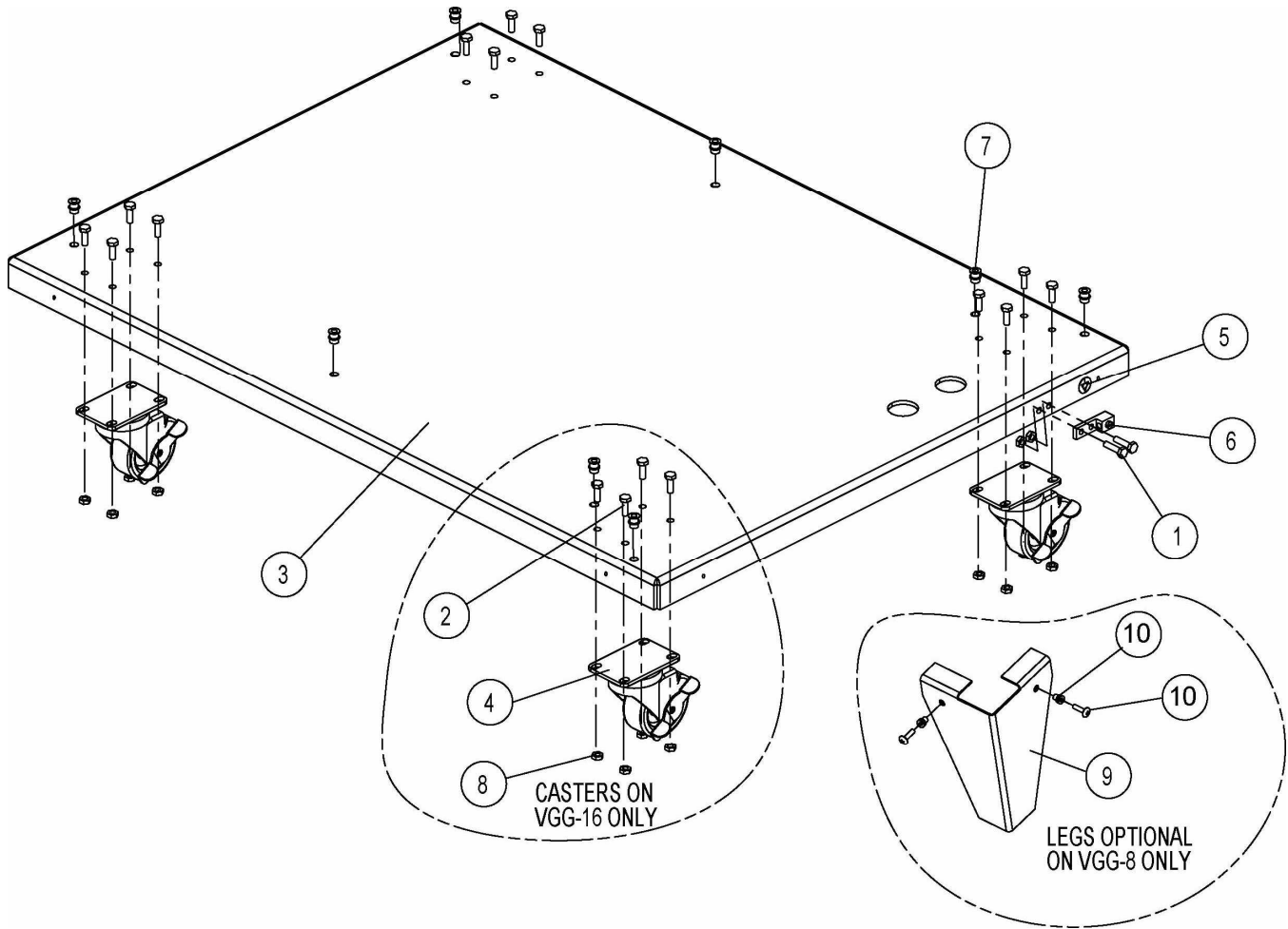

Table 2. Base Plate

ITEM #	PART #	QTY	DESCRIPTION
1	SCR060	2	SCREW, 1/4-20 X 1 HEX CAP
2	SCR059	16	SCREW, 1/4-20 X 3/4 HEX CAP
3	FB55158610 FB55163403	1	BASE PLATE, MOBILE (VGG-16) BASE PLATE, FIXED (VGG-8)
4	C0415	4	CASTER, 3"SWIVEL W/BREAK
5	N0543	1	DECAL, EQUIPOTENTIAL GROUND
6	F0191	1	GROUND LUG, TWO HOLE STREIGHT
7	F0082	8	THREAD INSERT 1/4-20 STEEL
8	WSH248	18	WASHERED LOCKNUT, 1/4-20 ZINC
9	PB55175000	4	LEG, BASE
10	F0083	8	THREADED INSERT, #10-32 (.08-.13)
11	SCR383	8	#10-32 x 1/2" SCREW

Figure 3. Control Panel Assembly

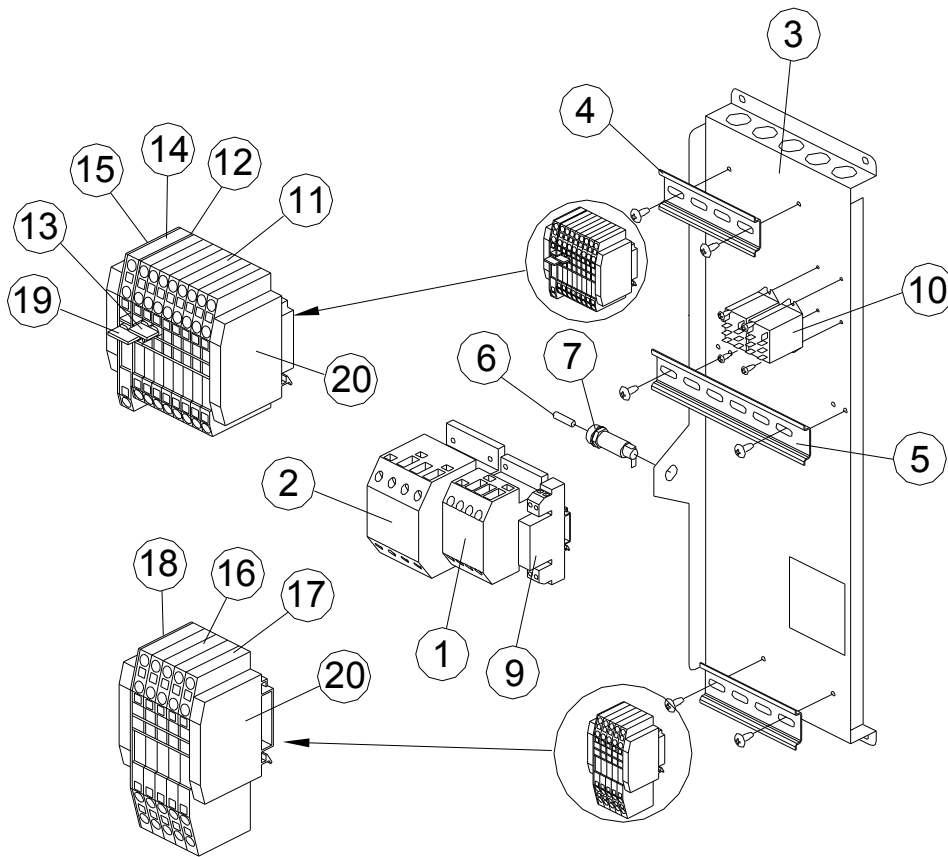

Table 3. Control Panel Assembly Parts

ITEM #	PART #	QTY	DESCRIPTION
1	R0127	1	CONTACTOR, 4 P, 25 A
2	R0172	1	CONTACTOR, 4 P, 45 A
3	FB30118909	1	CONTROL MOUNTING PLATE
4	MB55146600	2	DIN RAIL x 4 1/16"
5	MB55150900	1	DIN RAIL x 6 1/2"
6	F0394	1	FUSE, 8 A
7	FU004UK	1	FUSEHOLDER
8	WH0043	1	WIRING HARNESS, CONTROL PANEL *
9	R0176	1	RELAY, 5 A SOLID STATE
10	R0171	2	RELAY, SPDT, 230 V
11	TB0096	8	TERMINAL SECTION, 3 POLE, 12 AWG
12	TB0097	1	END PLATE, 3 POLE, 12 AWG
13	TB0098	1	TERMINAL JUMPER, 2 POLE, 12 AWG
14	TB0100	1	TERMINAL SECTION, 3 POLE, 10 AWG
15	TB0102	2	END PLATE, 3 POLE, 10 AWG
16	TB0103	4	TERMINAL SECTION, 4 POLE, 10 AWG
17	TB0104	1	TERMINAL GROUND, 4 POLE, 10 AWG
18	TB0105	1	END PLATE, 4 POLE, 10AWG
19	TB0106	1	TERMINAL JUMPER, 2 POLE, 10 AWG
20	TB0109	4	END STOP, TERMINALS

* - not shown

Figure 4. Control Plate, Standard Touch Tec

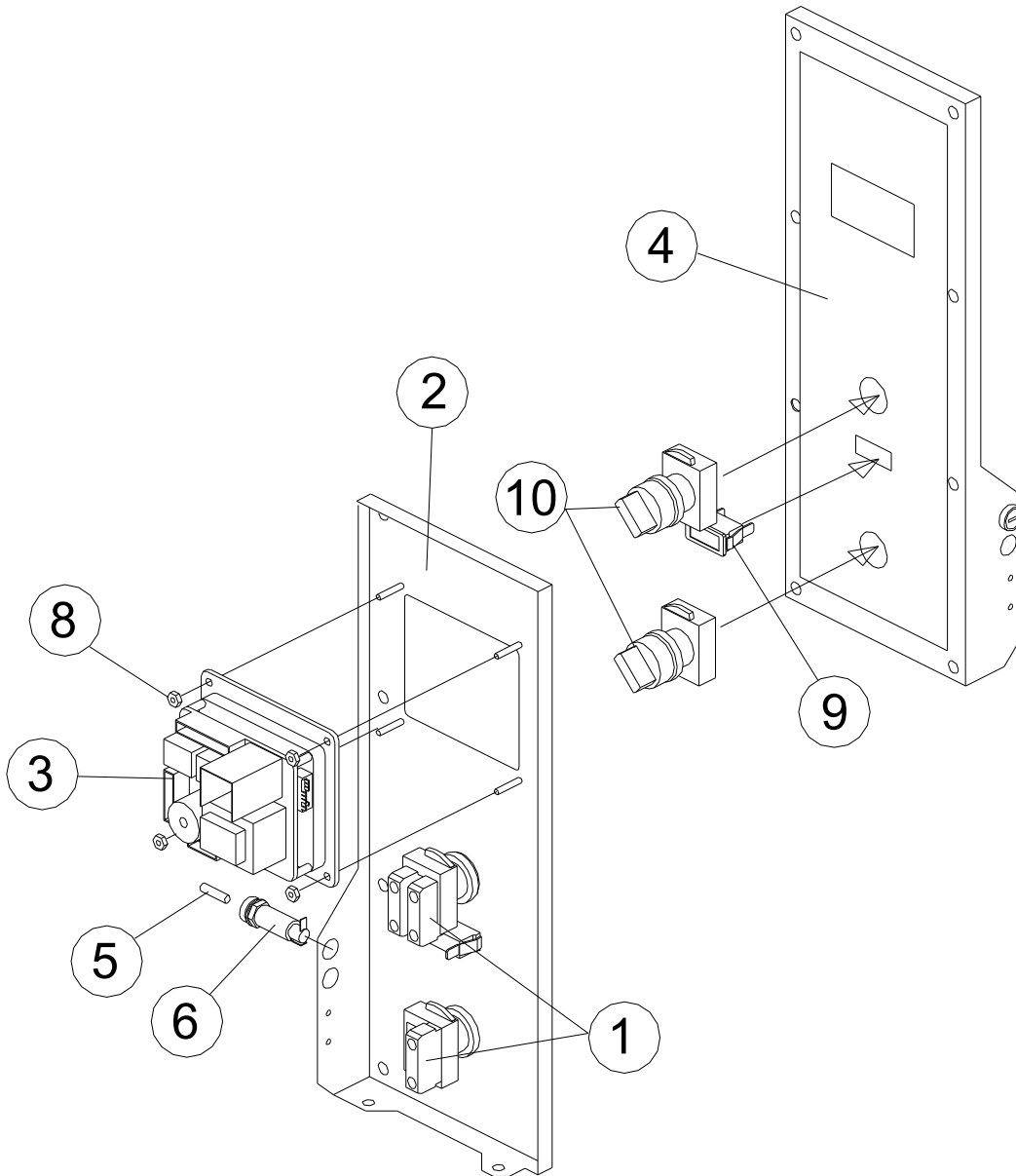

Table 4. Control Plate, Standard Touch Tec

ITEM #	PART #	QTY	DESCRIPTION
1	S0307	3	CONTACT BLOCK, 1 N.O.
2	FB55164310	1	CONTROL PLATE – TOUCH TEC
3	CP0046	1	CONTROLLER, OVEN
4	N0580	1	DECAL, TOUCH SCREEN
5	FU010UK	1	FUSE, 1/2 A - 5 x 20 mm
6	FU004UK	1	FUSEHOLDER - 5 x 20 mm
7	WH0023 *	1	HARNESS, CONTROL PLATE
8	NUT276	4	NUT, #8-32 KEPS
9	LI016UK	1	PILOT LIGHT, CLEAR - 250V
10	S0304	2	SWITCH OPERATOR, 2 POSITION

* - not shown

Figure 5. Control Plate, Color Touch Tec

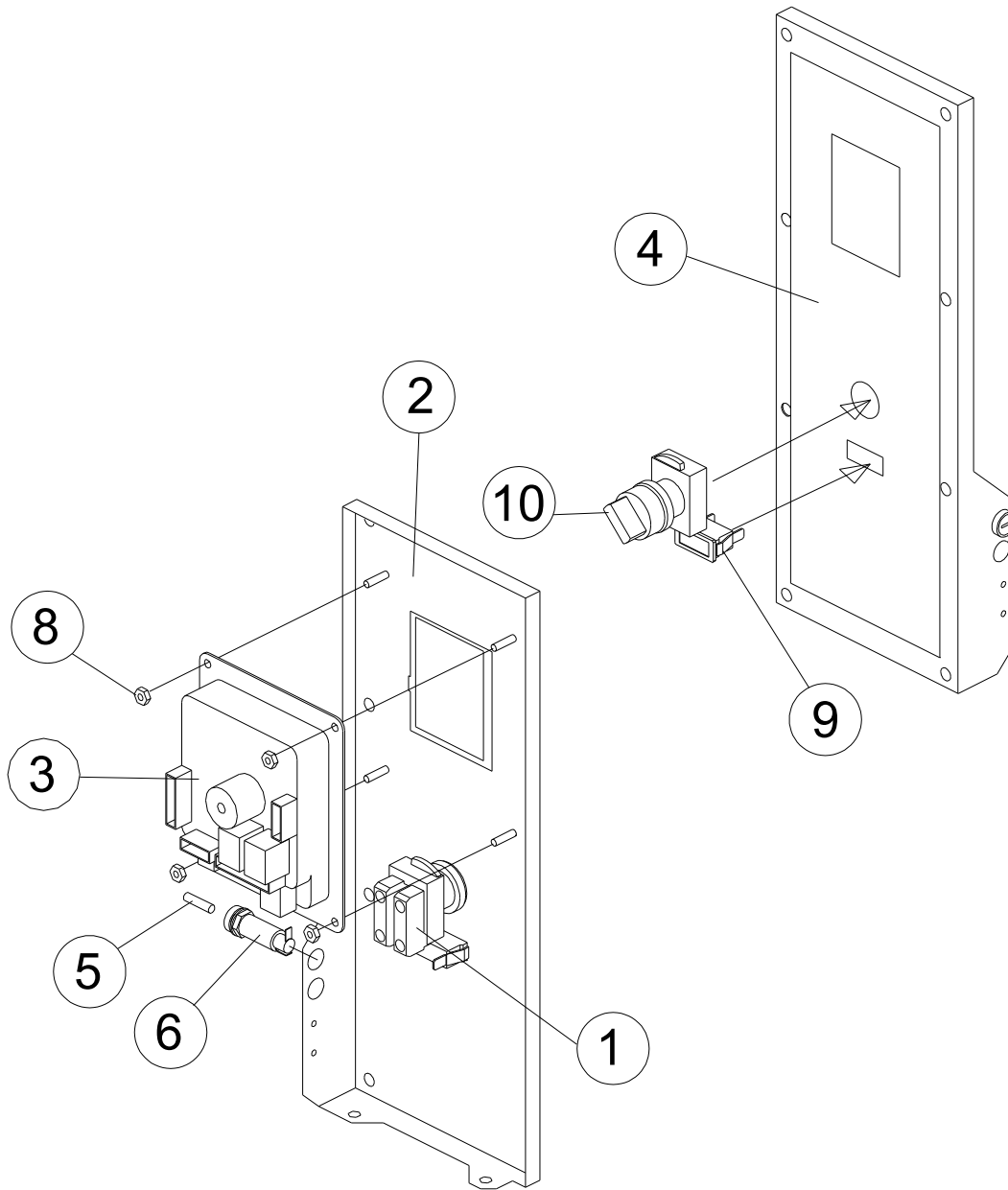

Table 5. Control Plate, Color Touch Tec

ITEM #	PART #	QTY	DESCRIPTION
1	S0307	2	CONTACT BLOCK, 1 N.O.
2	FB55163810	1	CONTROL PLATE – COLOR TOUCH TEC
3	CP0048	1	CONTROLLER, COLOR TOUCH TEC
4	N0575	1	DECAL, COLOR TOUCH SCREEN
5	FU010UK	1	FUSE, 1/2 A - 5 x 20 mm
6	FU004UK	1	FUSEHOLDER - 5 x 20 mm
7	WH0023 *	1	HARNESS, CONTROL PLATE
8	NUT276	4	NUT, #8-32 KEPS
9	LI016UK	1	PILOT LIGHT, CLEAR - 250V
10	S0304	1	SWITCH OPERATOR, 2 POSITION

* - not shown

Figure 6. Dripping Drawer

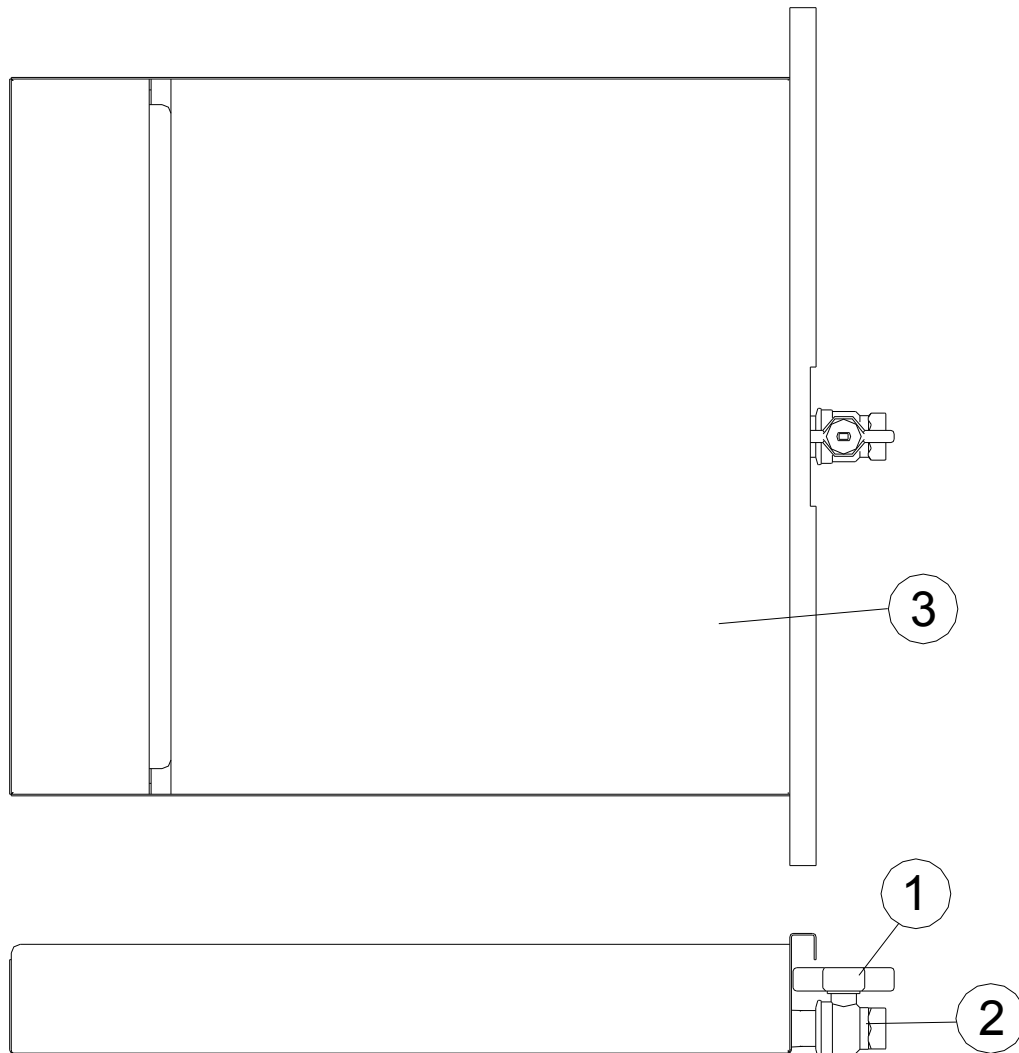

Table 6. Dripping Drawer

ITEM #	PART #	QTY	DESCRIPTION
1	V0020H	1	HANDLE FOR V0020 BALL VALVE
2	V0020	1	VALVE, BALL 3/4" FULL PORT
3	WB30123800 WB30126200	1	DRIPPING DRAWER w/ /DRAIN, COq DRIPPING DRAWER w/o DRAIN, COq

Figure 7. Inner Door

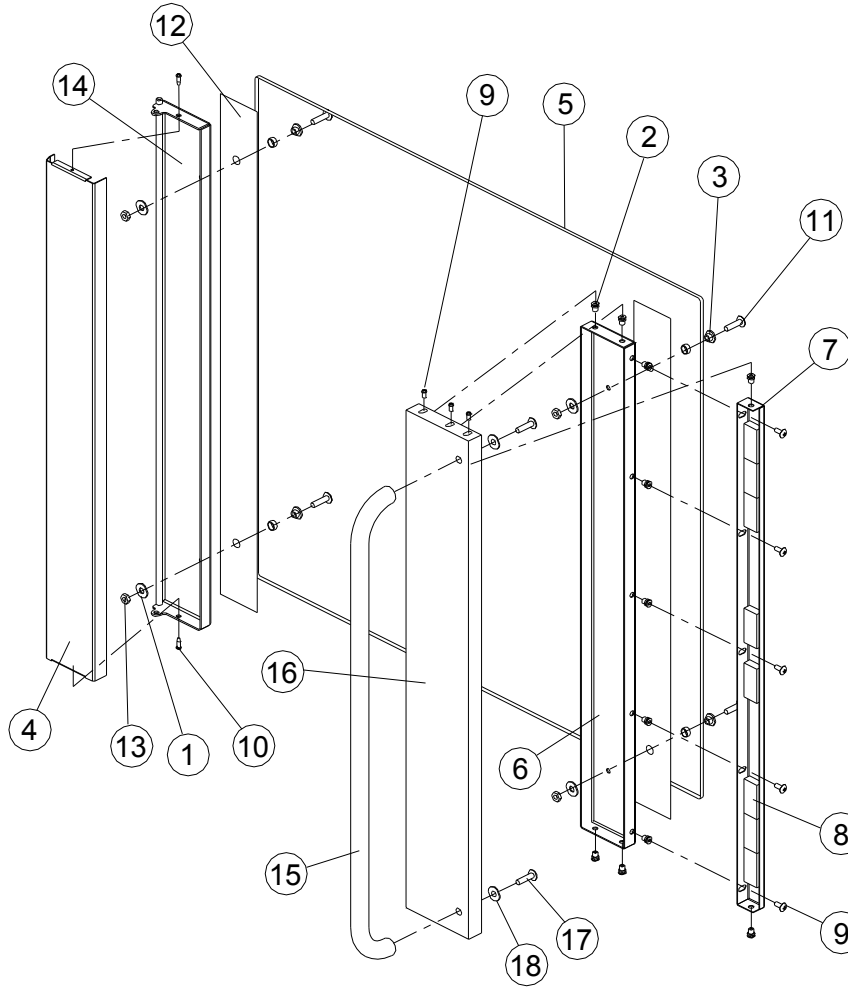

Table 7. Inner Door

ITEM #	PART #	QTY	DESCRIPTION
1	WSH266	4	1/4" FLAT WASHER
2	F0139	11	AVK HEX INSERT, #8-32 (.02-.08)
3	BU020UK	4	BUSHING - INNER DOOR GLASS
4	FB55140351	1	COVER - HINGE, VGG-5
5	GL0390	1	GLASS - INNER DOOR, COq
6	FB55157902	1	HANDLE BRKT-INNER DOOR, VGG-5
7	FB55158003	1	MAGNET MOUNT - INNER DOOR, VGG-5
8	MC0005	8	MAGNET, 1 7/8 x 7/8
9	SCR439	5	SCREW, #8-32X1/2" PHIL HD BLK
10	SCR007	2	SCREW, #8X3/4" PHIL HD-TYPE B
11	SCR418	4	SCREW, 1/4"-20X1 SLTD TRUSS HD
12	SP0045	2	SPACER - INNER DOOR, VGG-5
13	WSH248	4	WASHERED LOCKNUT, 1/4"-20
14	WB55157800	1	WELDMENT - HINGE, VGG-5
15	H0131	1	HANDLE, INNER DOOR
16	FB55153751	1	HANDLE COVER
17	SCR060	2	SCREW, 1/4"-20 X 1" HEX HEAD
18	FA55153002	2	WASHER, INNER DOOR HANDLE

Figure 8. Outer Door - Flat

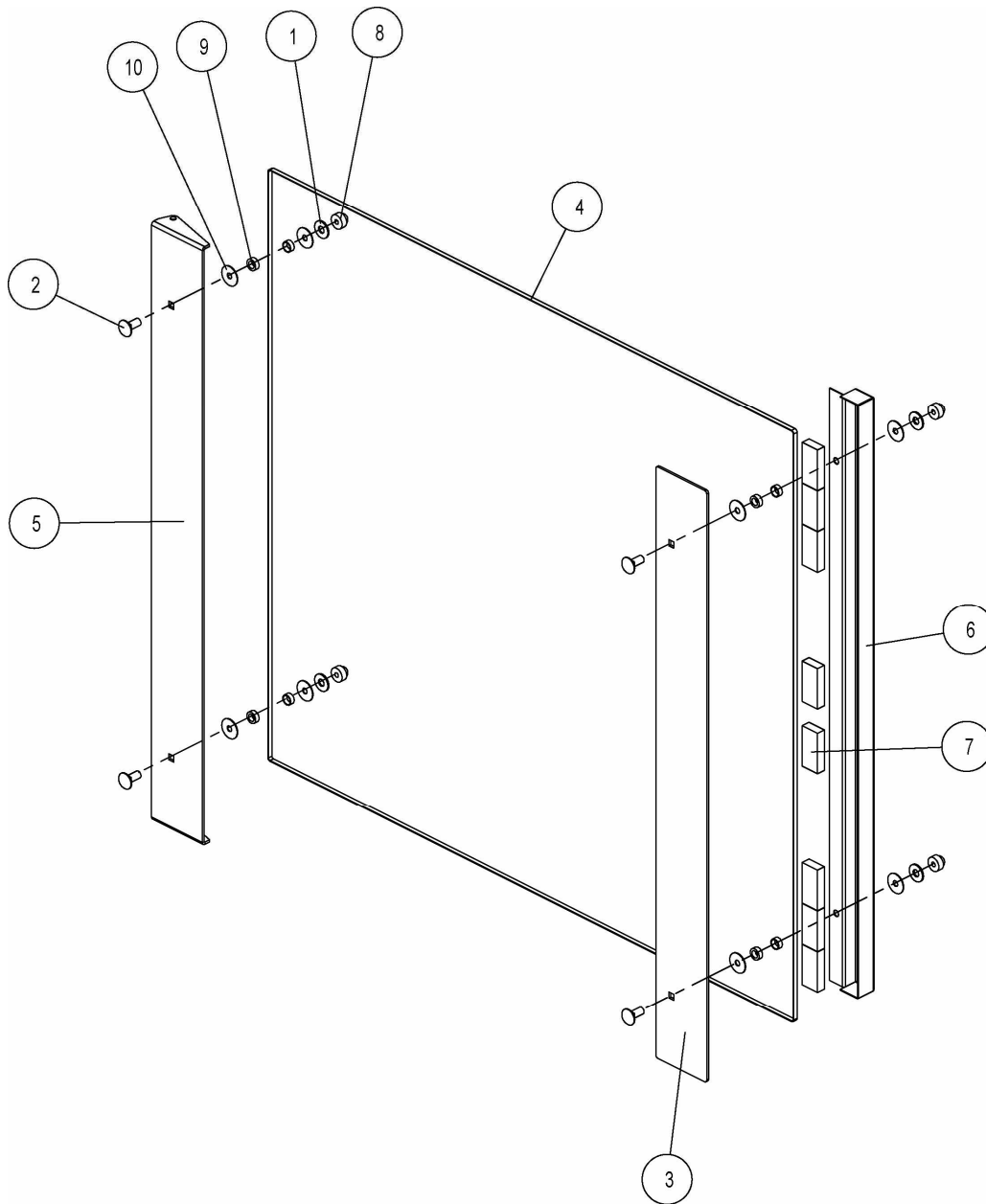

Table 8. Outer Door - Flat

ITEM #	PART #	QTY	DESCRIPTION
1	WSH266	4	WASHER, 1/4" FLAT S/S
2	BLT257	4	BOLT, 1/4-20 X 5/8 CARRIAGE
3	FB55148103	1	DOOR LATCH, FLAT DOOR, VGG-5
4	GL0390	1	GLASS, INNER DOOR - COq
5	FB55147903	1	HINGE, FLAT DOOR, VGG-5
6	FB55148003	1	MAGNET MOUNT, FLAT OUTER DOOR, VGG-5
7	MC0005	8	MAGNET, 1 7/8 X 7/8
8	NUT097	4	NUT, 1/4-20 SS 18-8 CAP
9	SP0031	4	SPACER, TEFLON-DOOR GLASS
10	WSH268	8	WASHER, TEFLON VG

Figure 9. Outer Door – Curved

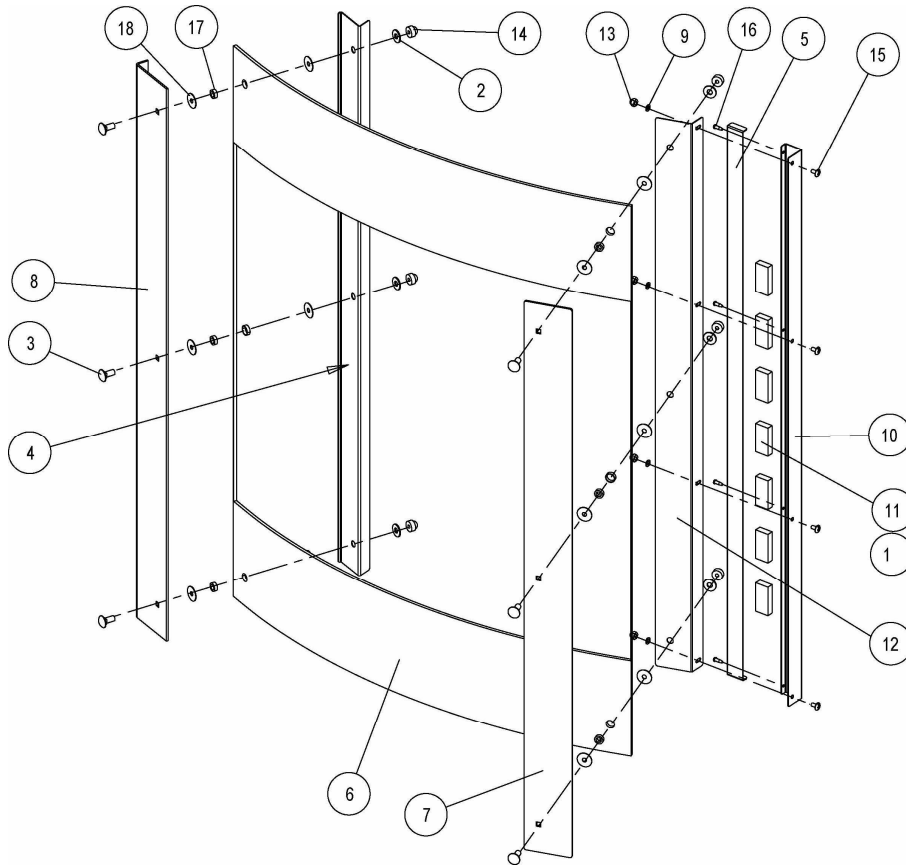
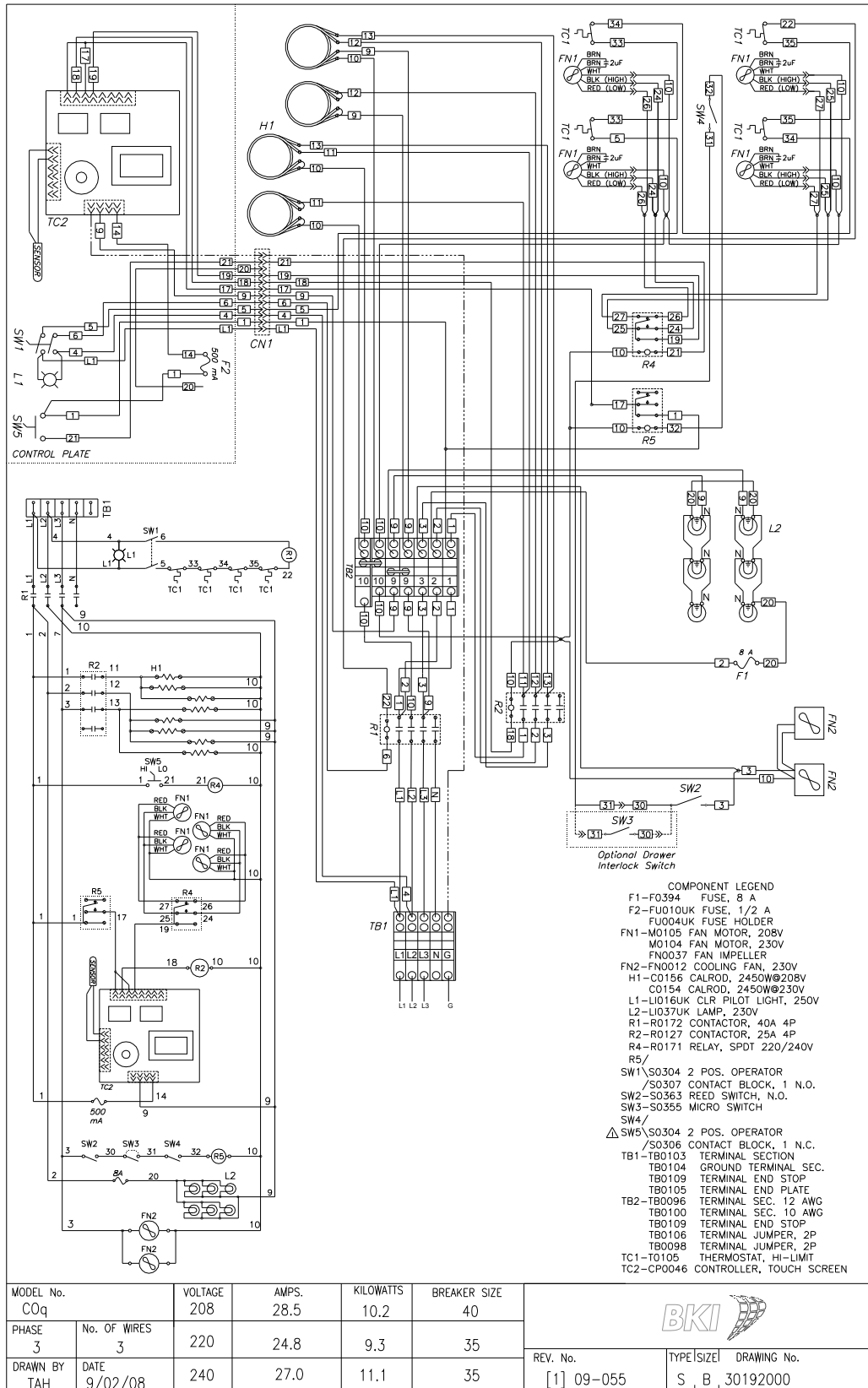
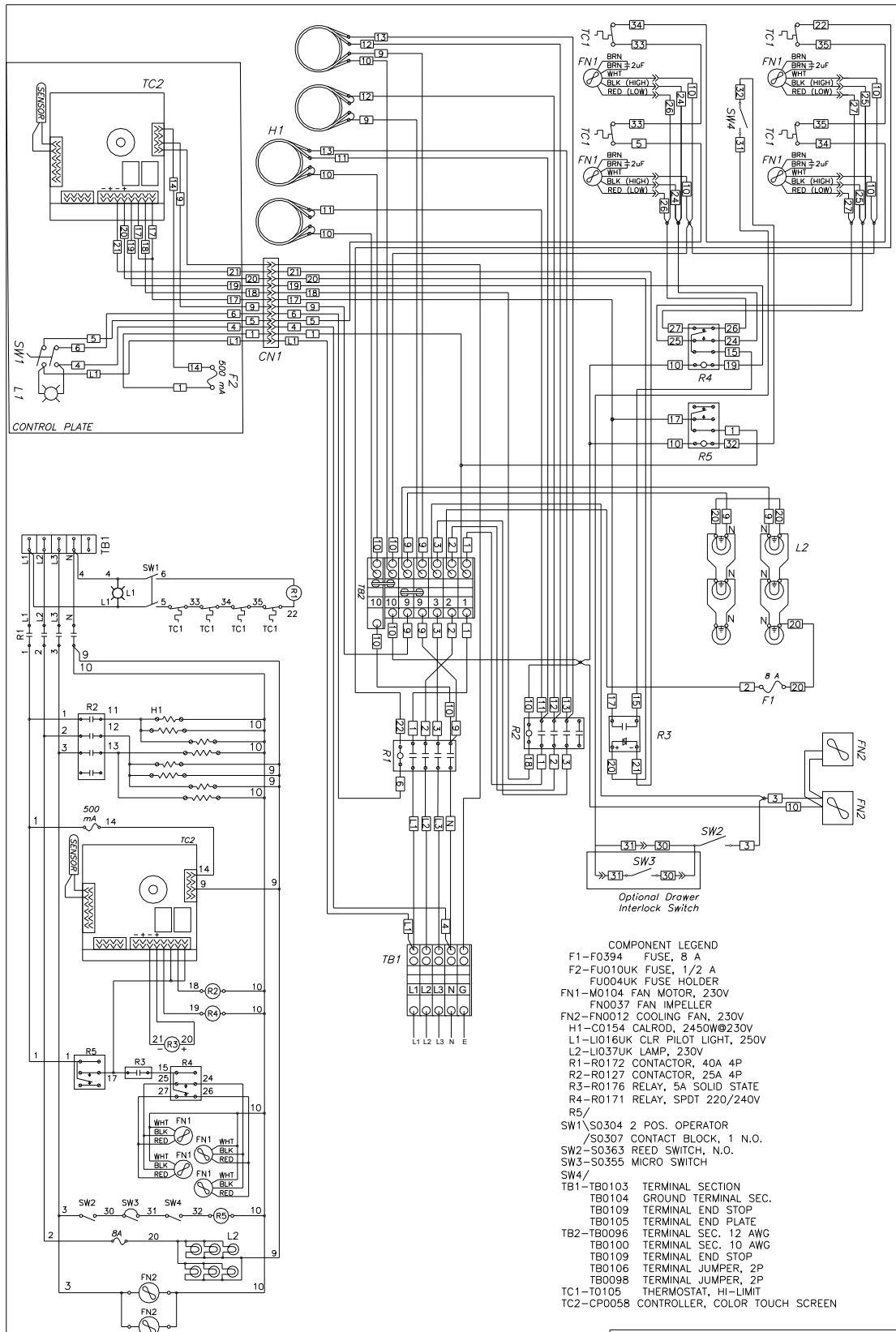

Table 9. Outer Door - Curved

ITEM #	PART #	QTY	DESCRIPTION
1	TP0037	1' 4"	TAPE, 7/8 DBL SIDE 3M6381 WHITE
2	WSH266	6	WASHER, 1/4" FLAT S/S
3	BLT257	6	BOLT, 1/4-20 X 5/8 CARRIAGE
4	FB55140703 or FB45443403	1	BUMPER BRKT OUTER DOOR, VGG-5 BUMPER BRKT OUTER DOOR, VGG-8
5	FB55141103 or FB45443503	1	COVER, MAGNET, VGG-5 COVER, MAGNET, VGG-8
6	GL0391M or GL0300M	1	OUTER DOOR GLASS, COq OUTER DOOR GLASS, VGG-8
7	FB55140803 or FB45443203	1	LATCH PLATE, OUTER DOOR, VGG-5 LATCH PLATE, OUTER DOOR, VGG-8
8	FB55140503 or FB30121403	1	HINGE PLATE, OUTER DOOR, VGG-5 HINGE PLATE, OUTER DOOR, COq w/ VGG GLASS
9	WSH246	4	WASHER, #10 INT TOOTH S/S
10	FB55141003 FB45455703	1	MAGNET MOUNT, OUTER DOOR, VGG-5 MAGNET MOUNT, OUTER DOOR, VGG-8
11	MC0005	7	MAGNET, 1 7/8 X 7/8
12	FB55140903 FB55126503	1	MAGNETIC CATCH BRKT, OUTER DOOR VGG-5 MAGNETIC CATCH BRKT, OUTER DOOR VGG-8
13	NUT132	4	NUT, 10-24 SS 18-8 HEX CAP
14	NUT097	6	NUT, 1/4-20 SS 18-8 CAP
15	SCR136	4	SCREW, 10-24 X 3/8 SLTD TRUSS
16	SCR006	4	SCREW, 8 X 1/2 PHIL PAN
17	SP0031	6	SPACER, TEFLON-DOOR GLASS
18	WSH268	12	WASHER, TEFLON VG

Wiring Diagrams





VOLTAGE			CURRENT (A)			POWER (W)			
220/380-230/400-240/415 V			L1	14.5	15.1	15.8	3186	3482	3792
50Hz, 3 Ph + N + E			L2	14.2	14.7	15.5	3112	3400	3702
MODEL No. COq			L3	13.8	14.3	15.0	3021	3300	3596
DRAWN BY	DATE	REV. No.	TYPE/SIZE/ DRAWING No.						
TAH	10/24/08		S B 30192100						





P.O. Box 80400, Simpsonville, S.C. 29680-0400, USA
<http://www.bkideas.com>

Made and printed in the U.S.A
LI0216/0204