



# ***TECHNICAL TRAINING COURSE***



<b>INDEX</b>		<b>Page</b>
<b>1.0</b>	<b>OVEN INSTALLATION</b>	<b>4</b>
1.1	POSITIONING	4
1.2	Water connection	4
1.3	Drain connection	5
1.4.1	Electric connection	5
1.4.2	Electric connection	6
1.5	Gas connection (gas ovens only)	6
1.6	Fumes exhaust	7
1.7	Adjust trolley of 20 1/1 and 20 2/1 ovens	8
<b>2.0</b>	<b>OVEN START-UP</b>	<b>8</b>
<b>3.0</b>	<b>ELECTRICAL COMPONENTS IDENTIFICATION</b>	<b>9</b>
3.1	Water electrovalves and injector codification (EU,EV,EL,ES,EA,ESH)	9
3.2	Transformers	10
3.3	Door micro-switch - SP	10
3.4	Resistance Elements contactor - KR	10
3.5	Motor thermal protection	11
3.6	Motor Inverter - power supply relay	11
3.7	Fuses	11
3.8	Automatic security thermostat of the boiler	11
3.9	Cavity security thermostat - F1	12
3.10	Water pressostat - PA (direct steam oven with washing system)	12
3.11	Meteo System probes	12
3.12	EMC filters - PFC, FLC	12
3.13	Air pressostat - P1 (gas ovens)	13
3.14	Gas blower - MB, control board PWM	13
3.15	Burner control - IGN	13
3.16	Gas valve - EVG	13
3.17	Motorized discharging valve - MS	14
3.18	Washing pump - PL	14
3.19	Detergent pump - PD	14
3.20	Flowmeter - HALL	14
3.21	Butterfly valve - MV	15
<b>4.0</b>	<b>GAS OVEN - SETUP</b>	<b>15</b>
4.1	Combustion analysys	15
4.2	Gas reference table	18
4.3	Setting ignition probes and detecting flame probe	18
4.4	Gas change procedure	19
4.5.1	Fixing the burner to the exchanger : GASKET SEQUENCE	21
4.5.2	Fixing the burner to the exchanger : NOTES	22
<b>5.0</b>	<b>ELECTRONIC BOARDS and configurations</b>	<b>23</b>
5.1	Configuration of electronic boards serial connections	24

<b>INDEX</b>		<b>Page</b>
5.2	I-O Check	26
5.2.1	I-O Check - Probes	26
5.2.2	I-O Check - Digital inputs	27
5.2.3	I-O Check - Digital outputs	28
5.3	HACCP recording (touch board)	29
5.3.1	Cooking log memorisation	29
5.3.2	Print-out example	29
5.3.3	HACCP parameters	29
5.3.4	Download HACCP log ---> USB pen drive	30
5.4	Wash log - download - erase	30
5.5	Upload-download recipes	31
5.5.1	Upload recipes	31
5.5.2	Download recipes	31
5.6	Wash log - download - erase	32
5.7	ALARMS DESCRIPTION	33
5.8	Alarm log - download - erase	34
5.9	System info menu	35
5.10	Inverter alarm signal diagnostic	35
5.11	Technical parameters	36
5.12	Firmware upgrade	37
5.13.1	Upload new parameters	38
5.13.2	Download parameters file from the oven	38
5.13.3	Upload new parameters	39
5.13.4	Download parameters from the oven	40
<b>6.0</b>	<b>MAINTENANCE</b>	<b>41</b>
6.1	Boiler descaling	41
6.2	Cleaning oven cavity	43
6.3	Cleaning panel air filter	44
6.4	Adjustment of the hinges and the closing pivot of the door	44
6.5	Changing door lights and glass cleaning	45
6.6	Washing sprinkler cleaning	45
<b>7.0</b>	<b>SPECIAL MAINTENANCE</b>	<b>46</b>
7.1	Boiler opening and check	46
7.2	Fans replacement	47
7.3	Door gasket replacement	51
7.4	Complete door handle replacement	52
<b>8.0</b>	<b>ELECTRICAL DRAWINGS</b>	<b>54</b>
<b>9.0</b>	<b>SPARE PARTS EXPLODED VIEW</b>	<b>62</b>

## 1 INSTALLATION

### 1.1 POSITIONING

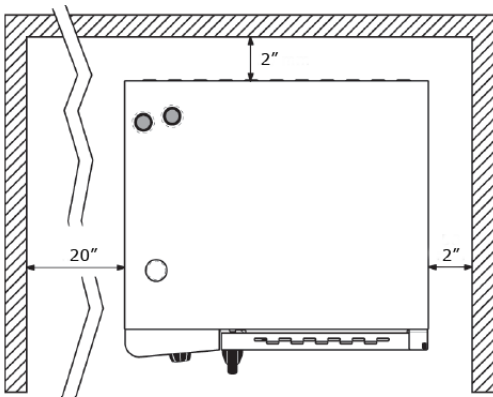

The appliances have been designed for installation in closed premises, they cannot be used in the open air and cannot be exposed to rain.

The place of installation of the oven must have a solid, flat and horizontal surface able to safely support both the mass weight of the appliance/support and that of maximum load capacity.

The appliance must be placed in adequately ventilated premises.

The oven must only be installed on a stable support. The appliance must be removed from its packaging, its integrity checked and arranged in the place of use, being careful not to position it above or against walls, sides, partition walls, kitchen cabinets or covers in flammable material.

We recommend scrupulously complying with the fireproof Standard in force.



There must be a **minimum distance of 2"** on all sides between the oven and the walls or other equipment. We recommend **leaving 20"** of space between the left side of the oven and the corresponding room wall, for easy oven installation and its subsequent maintenance.

All materials used for packaging are compatible with the environment; they must be safely kept and disposed of according to the Standard in force.

The oven must be levelled: to regulate the height of the adjustable feet act, using as reference a spirit level. Significant unevenness or inclinations can negatively influence the functioning of the oven. Slowly remove all protective film from the appliance external panels, being careful not to leave traces of adhesive. Check that the heat disposal or inlet slots and openings are not obstructed.

### 1.2 WATER CONNECTION

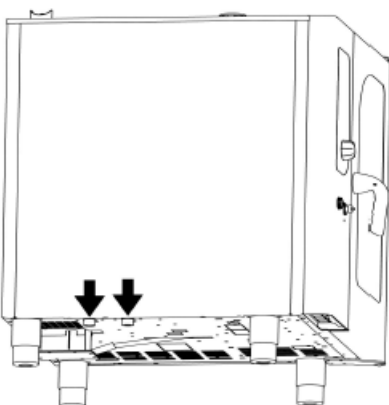

The water pressure must be max. 6 bar. Should the water pressure from the mains be higher than such value, install a pressure reducer upstream of the oven. The minimum water temperature for the correct functioning of the oven must be higher than 0.5 bar. The oven has a softened water inlet. Always install a water softener to bring the hardness of the water at appliance inlet within the values of between 5 TH and 10 TH. If the oven is equipped with automatic washing system and the water hardness is greater than 10 TH it recommended to use softened water for the second water inlet. Connect the

"Water" duct to the specific cold water mains, and interpose a shut-off cock and filter. Before connecting, let sufficient amount of water flow to clean the duct from any iron residues. Ensure the shut-off cock is located in a place and in a manner to be easily activated at any moment by the operator.

Attention: in case of water drain pipe fault, it must be replaced with a new one and the old and faulty one must never be re-used.

**1.3 DRAIN CONNECTION**

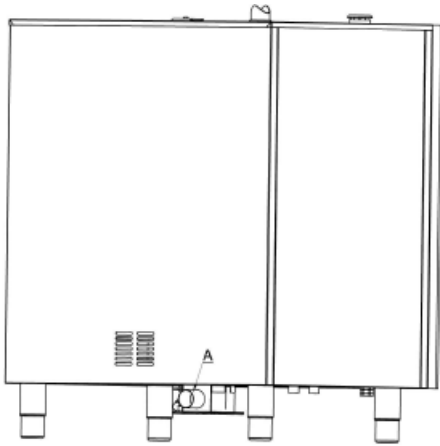

The oven is equipped with a water draining device; such device is located at the bottom in the rear part of the appliance and has a tube with a 2" diameter. Connect the tube that protrudes from the draining device. The draining device is a siphon; we recommend connecting the tube on an open funnel. Check that the internal siphon is full of water and, if not, fill it by introducing water through the drain in the cooking compartment.

**1.4.1 ELECTRIC CONNECTION**

The electric system, as prescribed and specified by the Standard in force, must be equipped with an efficient ground. It is possible to guarantee the electric safety of the appliance only in the presence of Standard electric system.

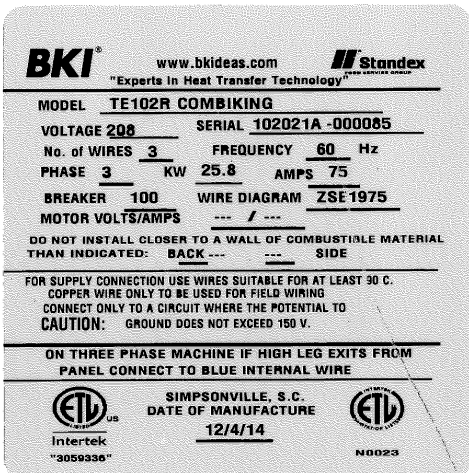

For direct connection to the mains it is necessary to interpose a device between the equipment and the same mains, dimensioned depending on the load, that ensures its disconnection and which contacts have an opening distance enabling the full disconnection, in compliance with the installation regulations; this device also must be located in a place and in a manner to be easily accessible at any moment by the operator.

Bring the main switch, to which the power supply cable plug will be collected, in position 0 (zero).

Have professionally qualified staff check that the plug cables section is adequate to the power absorbed by the appliance.

Loosen the screws fixing the left side of the oven and extract it.

Place the power supply cable inside the cable gland hole in the lower part, on the left of the oven. Connect the cable to the terminal board following the indications on "tab 1".

Lock the cable with the cable gland.

ELECTRIC OVENS	GAS OVENS
L1 L2 L3 $\perp$	L N $\perp$

**tab 1**

The power supply voltage with machine functioning, must not be different from the nominal voltage value of  $\pm 10\%$ .

## 1.4.2 ELECTRIC CONNECTION

When a high current flows through a conductor, differences in potential appear between the conductor and nearby metallic surfaces near the appliance. As a result, sparks may be produced between the appliance and surrounding metal surfaces. These sparks could cause serious injury, damage, or fire.

BKI provides an Equipotential ground terminal for the connection of a bonding conductor after the installation of the appliance per IEC60417-1. This terminal is located on the inside of the Power Entry Supply box near the Earth connection and is marked with this symbol:

For gas ovens, complete gas connection to the appliance before assembling the oven side again; for electric ovens assemble the oven side.



## 1.5 GAS CONNECTION (GAS OVENS ONLY)

The oven is originally calibrated for functioning with the gas type specified during ordering. The type of gas for which the oven is adjusted is reported on the technical plate on the appliance. During testing, ascertain the factory calibrations carried out on the burners are appropriate for the specific installation type, by means of analysis of the gases produced by combustion (CO<sub>2</sub> and CO) and check of the thermal capacity.

Specifically, with oven functioning at full capacity, the values of the undiluted CO present during draining, must be within 300 ppm (normally a well calibrated pre-mix system does not produce CO which mean the value should be 0).

If the presence of undiluted CO over such limit is detected, the adjustment of the burners must be checked by a technician authorised by the manufacturer, who will make all due amendments

to the devices governing combustion and to the relative parameters. The detected data must be recorded and become integrating part of the technical documentation of that appliance.

GK		CAT	G30	G31	G20	G25	COUNTRY
CE 0051	51803800	II 2H3+	P mbar 20-30	37	20	/	IT-ES-IE-PT-GB-GR-CH
TYPE	A <sub>1</sub>	II 2H3RP	P mbar 30	30	20	/	IT-DE-FR-IE-NO-UK-CZ-SK-HI-SE
MOD	AMMG102	II 2E+3+	P mbar 20-30	37	20	25	FR-BE
NR	009701/09/14	II 2H3RP	P mbar 50	50	20	/	AT-CH
		II 2ELL3RP	P mbar 50	50	20	20	DE
		II 2L3RP	P mbar 30	30	/	25	NL
Σ Qn	19,0 kW	II 2E3+	P mbar 20-30	37	20	/	LU
G30	G20	G25	II 3RP	P mbar 30	30	/	MT-IS-NO-CY
1,49	2,01	2,33	II 3+	P mbar 20-30	37	/	CY
kg/h	m <sup>3</sup> /h	m <sup>3</sup> /h	II 2E	P mbar /	/	20	PL
PREDISPOSTO A GAS - PREVU AU GAZ PRESET FOR GAS - EINGESTELLT AUF GAS PREDISPOSTO A GAS - PREDISPOSTO A GAS		G20 20		mbar			
120V	60 Hz	0.60 kW	IPX3	EN 203-1	MADE IN ITALY		

### Installation prescriptions

The oven installation and commissioning operations must be carried out only by qualified staff according to regulations and standards in force.

The gas systems, the electric connections and the installation premises of the appliances must be compliant with regulations and Standards in force.

Bear in mind that the air necessary for combustion of the burners is of 2 m<sup>3</sup>/h per kW of installed power.

In activities open to the public, the Standards for the safety prevention of accidents and fire and panic must be complied with.

The connection to the gas supply fitting can be carried out using flexible metal piping, interposing an approved shut-off cock in an easily accessible point.

Ensure that the flexible metal connection tube to the gas inlet fitting does not touch overheated parts of the oven and that it is not submitted to torsion or extension stresses.

Use securing clips compliant with installation Standards.

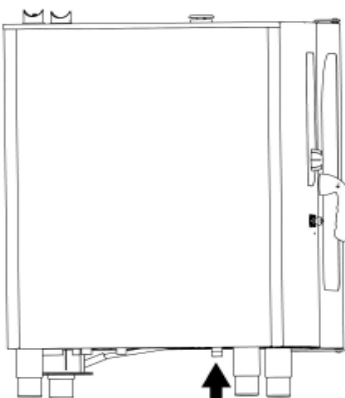

### Checks to be carried out before installation

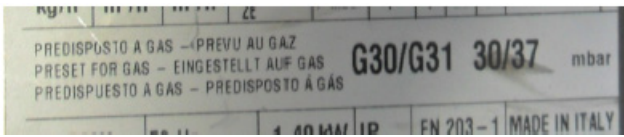

On the technical plate located on the left side of the oven check that the appliance has been tested for the type of gas available with the user.

Check the data on the technical plate that the pressure reducer capacity is sufficient for powering the equipment.

Avoid interposing section reductions between the reducer and the appliance.

We recommend mounting a gas filter upstream of the pressure regulator to guarantee optimal oven functioning.

Connect the oven to the gas supply system by means of special 1/2" NPG tube.

After gas connection, check there are no leaks on the joints and fittings. For this purpose, use soapy water or a specific foamy product to detect leaks.

It is opportune for the routine maintenance of the gas ovens to be carried out yearly, in compliance with specific Standards, by an authorised technician; during which the fuel gas will be analysed and the thermal power checked.

## 1.6

## FUMES EXHAUST

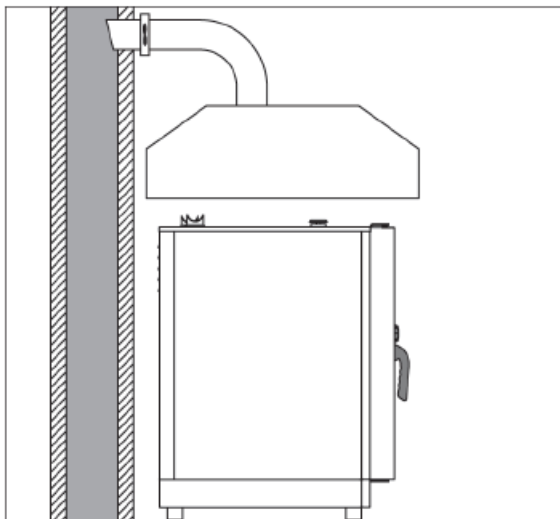

In compliance with installation Standards, the ovens must be started in premises suitable for evacuation of the combustion products.

It is possible to connect the flue passage by means of a forced evacuation system, like a hood equipped with mechanical extractor fan. In this case, the gas supply to the appliance must be directly controlled by such system and must interrupt should capacity drop below the prescribed values. When the appliance is installed underneath the extractor hood, check that the following indications are complied with:

- the extracted volume must be above that of the generated fuel gas (see Standard in force);
- the material with which the hood filter is made must resist the fuel gas temperature that, at conveyor outlet, can reach 572°F;
- the end of the evacuation duct of the appliance must be positioned inside the projection of the hood base perimeter;
- the re-admission of the gas to the appliance must only be possible manually.

## 1.7 ADJUST TROLLEY OF 20 1/1 AND 20 2/1 OVENS

A correct adjustment of the coupling between trolley and oven allows to prevent steam or water leakage, when the trolley is inserted inside the oven with the door closed.

1. The oven must be levelled to allow the edge of the sheet metal seal of the trolley to remain about 3 mm under the glass limit of the oven door.
2. Then screw spacers must be adjusted between the front and the stop of the trolley, at 13 - 15 mm height.

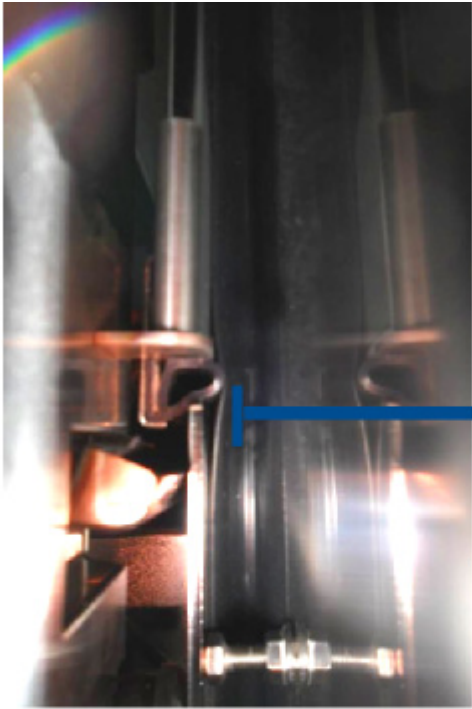

# NO

In this picture the gasket placed under the glass is too compressed and so the front gasket crushes until drawing.



# YES

In this picture the distance between the trolley and the door glass has been reduced, the gasket is less compressed and it does not overhang. In this way the front gasket does not deform itself.

## 2.0 OVEN START-UP

Before commissioning the oven, scrupulously carry out the necessary checks to ensure the compliance of the systems and installation of the appliance with the legal Standards and technical and safety indications in the user manual.

**The following points must also be satisfied:**

- The ambient temperature of the place of installation of the oven must be higher than 4°F.
- The cooking compartment must be empty.
- All packaging must be fully removed, including the protective film applied on the oven walls.
- The air vents and louvers must be open and not obstructed.
- The eventually dismantled oven pieces must be, for installation purposes, re-mounted.
- The main electric switch must be closed and the water and gas shut-off cocks upstream of the appliance must be open.

**3.0 ELECTRICAL COMPONENT IDENTIFICATIONS**

**3.1 WATER ELECTRO-VALVES AND INJECTOR CODIFICATION (EU, EV, EL, ES, EA, ESH)**

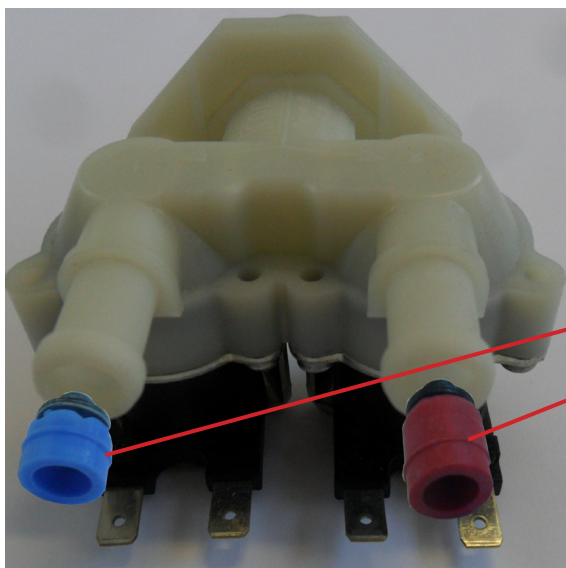

The solenoid valve is the device that supplies water in the pre-established times and methods.

At the electro-valve outlet a injector (nozzle) is normally applied.

**STEAMBOX VALVE, NOZZLE:**

	HUMIDIFIER	BOILER (VER. 'H' ONLY)	WASHING SYSTEM
ABHE061	<b>BROWN</b> 0,07 ÷ 0,14 L/min	RED 0,2 ÷ 0,3 L/min	NO WASH. SYS.
ABHE062-101	RED 0,2 ÷ 0,3 L/min	RED 0,2 ÷ 0,3 L/min	NO WASH. SYS.
ABTE061-062-101	RED 0,2 ÷ 0,3 L/min	NO BOILER	NO WASH. SYS.
ABTE102-ABHE102	YELLOW 0,32 ÷ 0,42 L/min	YELLOW 0,32 ÷ 0,42 L/min	NO WASH. SYS.
ABTE201-ABHE201	2 X RED 0,2 ÷ 0,3 L/min	YELLOW 0,32 ÷ 0,42 L/min	NO WASH. SYS.
ABTE202-ABHE202	2 XYELLOW 0,32 ÷ 0,42 L/min	YELLOW 0,32 ÷ 0,42 L/min	NO WASH. SYS.
ABHE061R	<b>BROWN</b> 0,07 ÷ 0,14 L/min	RED 0,2 ÷ 0,3 L/min	BLU 4,5 ÷ 6 L/min
ABHE062R-ABHE101R	RED 0,2 ÷ 0,3 L/min	RED 0,2 ÷ 0,3 L/min	BLU 4,5 ÷ 6 L/min
ABTE061R-ABTE061R-062R-101R	RED 0,2 ÷ 0,3 L/min	NO BOILER	BLU 4,5 ÷ 6 L/min
ABHE102R	YELLOW 0,32 ÷ 0,42 L/min	YELLOW 0,32 ÷ 0,42 L/min	BLU 4,5 ÷ 6 L/min
ABTE201R-ABHE201R	2 X RED 0,2 ÷ 0,3 L/min	YELLOW 0,32 ÷ 0,42 L/min	BLU 4,5 ÷ 6 L/min + 2 NERO 1,9 ÷ 3,5 L/min
ABTE202R-ABHE202R	2 XYELLOW 0,32 ÷ 0,42 L/min	YELLOW 0,32 ÷ 0,42 L/min	BLU 4,5 ÷ 6 L/min + 2 NERO 1,9 ÷ 3,5 L/min
ABHG061-062-101	RED 0,2 ÷ 0,3 L/min	RED 0,2 ÷ 0,3 L/min	NO WASH. SYS.
ABHG102	YELLOW 0,32 ÷ 0,42 L/min	YELLOW 0,32 ÷ 0,42 L/min	NO WASH. SYS.
ABHG201	2 X RED 0,2 ÷ 0,3 L/min	YELLOW 0,32 ÷ 0,42 L/min	NO WASH. SYS.
ABHG202	2 XYELLOW 0,32 ÷ 0,42 L/min	YELLOW 0,32 ÷ 0,42 L/min	NO WASH. SYS.
ABHG061R-062R-101R	RED 0,2 ÷ 0,3 L/min	RED 0,2 ÷ 0,3 L/min	BLU 4,5 ÷ 6 L/min
ABHG102R	YELLOW 0,32 ÷ 0,42 L/min	YELLOW 0,32 ÷ 0,42 L/min	BLU 4,5 ÷ 6 L/min
ABHG201R	2 X RED 0,2 ÷ 0,3 L/min	YELLOW 0,32 ÷ 0,42 L/min	BLU 4,5 ÷ 6 L/min + 2 NERO 1,9 ÷ 3,5 L/min
ABHG202R	2 XYELLOW 0,32 ÷ 0,42 L/min	YELLOW 0,32 ÷ 0,42 L/min	BLU 4,5 ÷ 6 L/min + 2 NERO 1,9 ÷ 3,5 L/min

### 3.2 TRANSFORMERS



**TR1**

**TR1** – Electronic board transformer (for main card and power cards): power 17 VA, PRY 230 Volts - SEC 2 x 12Volt (12VA + 5VA)

**TR2-TR3** – PWM card and fan blower transformer: power 60 VA, PRY 230 Volts - SEC 24Volt.

**TRAL** - Halogen light transformer: power 60 VA , PRY 230 Volts - SEC 12 Volt

**TRAF (ELE ovens)** - Main power supply transformer: power 250 VA , PRY 208 Volts - SEC 230 Volt

**TRAF (GAS ovens)** - Main power supply transformer: power 1500 VA , PRY 120 Volts - SEC 230 Volt

**TR2**



**TRAL**

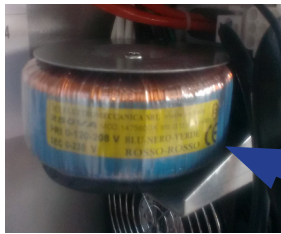

**TRAF**

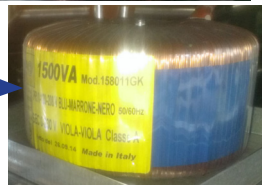

### 3.3 DOOR MICRO-SWITCH - SP

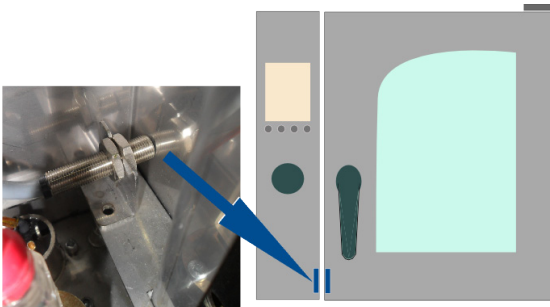

The door micro-switch is a magnetic type. The magnet is applied inside the door. The sensor is fixed inside the main control panel.

### 3.4 RESISTANCE ELEMENTS CONTACTOR - KR

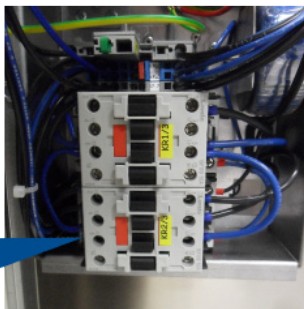

**KR 1/3** = 1 elements of the resistance

**KR 2/3** = 2 elements of the resistance

FULL POWER = KR 1/3 + KR 2/3

or

**KR 1/2** = 1/2 elements of the resistance

**KR 2/2** = all elements of the resistance

FULL POWER = KR 1/2 + KR 2/2

**3.5 MOTOR THERMAL PROTECTION**

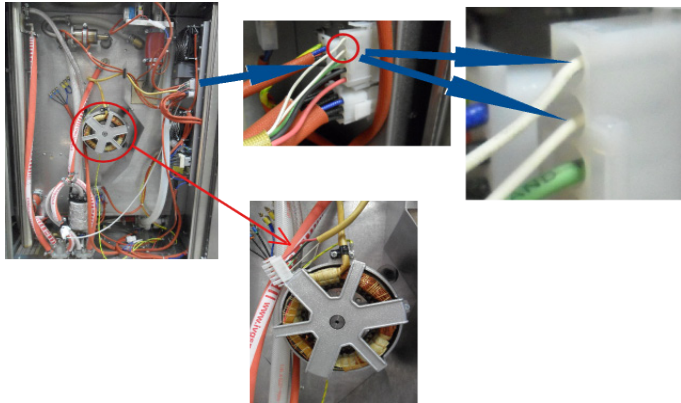

The white wires are connected to a temperature sensor inside the motor (klikson)

**3.6 MOTOR INVERTER - POWER SUPPLY RELAY - FUSE**

The Inverter CARD **INV** control the fonctionament of the oven motor/s.  
The Relay **K0** switch on/off the main power supply of the Inverter.

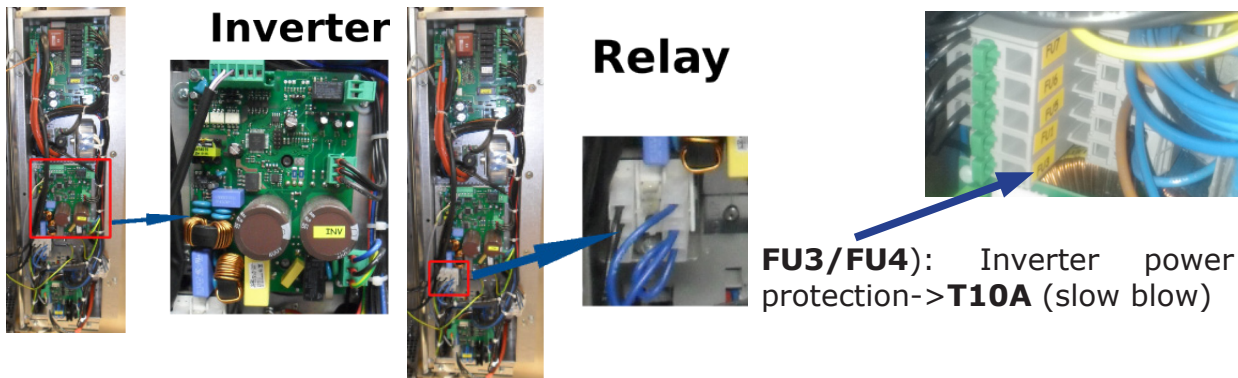

**FU3/FU4):** Inverter power supply protection->**T10A** (slow blow)

**3.7 FUSES**

- FU0** : Power supply transformer protection  
TRAF 208/230 250VA -> **T2A** (slow blow)  
TRAF 120/230 1500VA -> **T15A** (slow blow)
- FU1** or **FU2**: gas burner control protection ->**F2A** (fast)
- FU5** : Main board transformer protection (TR1)->**T200mA** (slow blow)
- FU6** : Light transformer protection (TRAL)->**T315mA** (slow blow)
- FU7** : Pwm board transformer protection (TR2)->**T315mA** (slow blow)

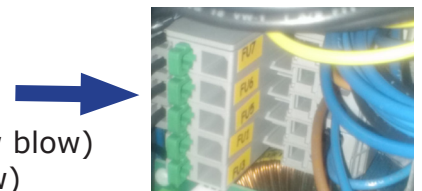

**3.8 AUTOMATIC SECURITY THERMOSTAT OF THE BOILER**

The automatic security thermostat prevent functioning of the boiler without water. It reset itself.



- 1** BOILER ELEMENTS PHASE CONNECTION
- P(L)** ELECTRONIC BOARD RELAY

**3.9 CAVITY SECURITY THERMOSTAT - F1**

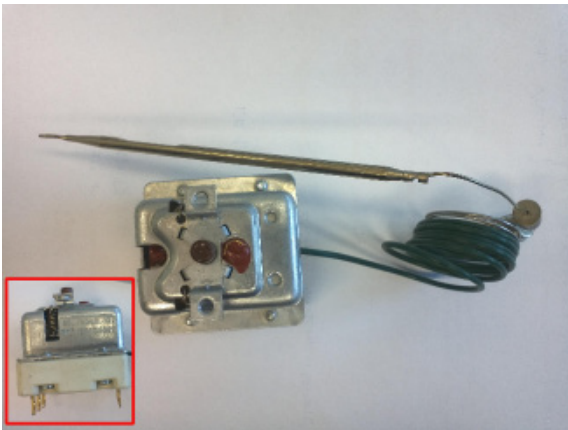

If the temperature inside the cooking compartment reaches 662°F, the safety thermostat interrupts supply to the oven's heating elements.

To reset it push the red (or brown) button.

**3.10 WATER PRESSOSTAT - PA (DIRECT STEAM OVEN WITH WASHING SYSTEM)**

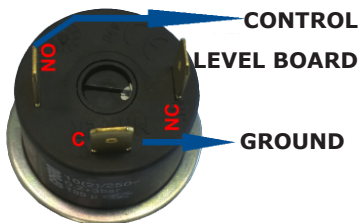

Connect 'C' plug to the ground cable and 'NO' plug to main board control level.

**3.11 METEO SYSTEM PROBES**

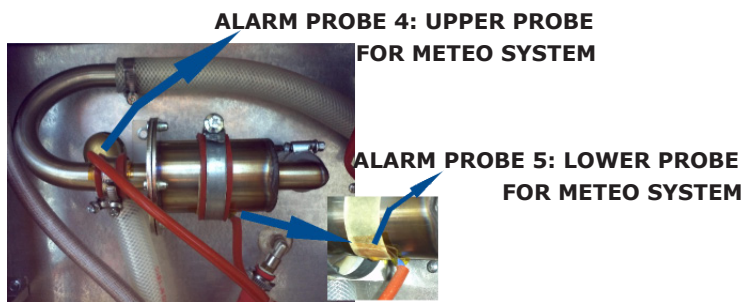

**3.12 EMC FILTERS - PFC, FLC**

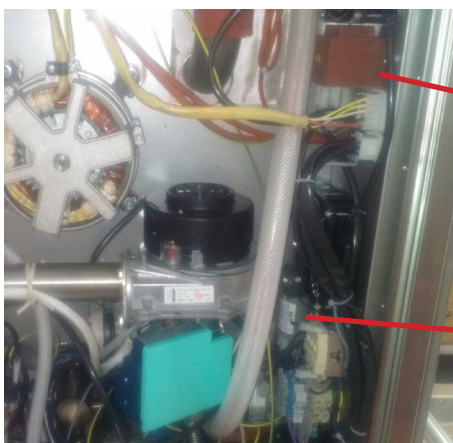

**PFC** = Inductance for Harmonic noise of Inverter



**FLC** = Line filter

**3.13 AIR PRESSOSTAT - P1 (gas ovens)**

The air pressostat control the correct chimney evacuation



**3.14 GAS BLOWER - MB / CONTROL BOARD - PWM**



**3.15 BURNER CONTROL - IGN**

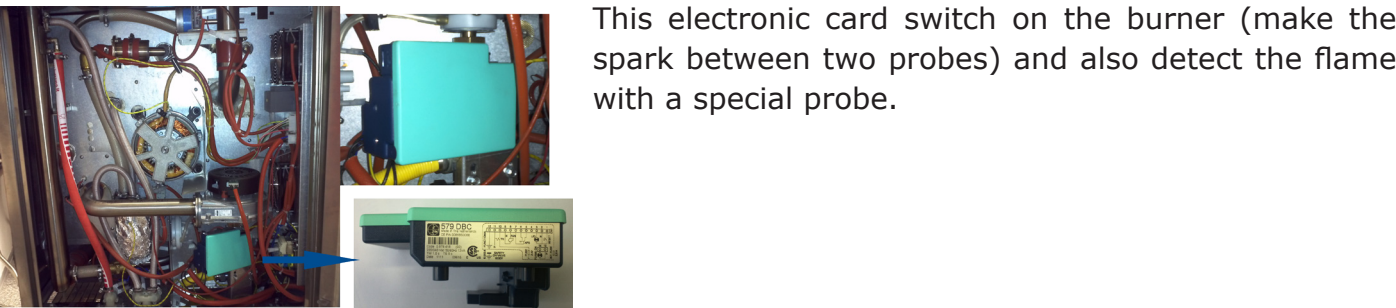

**3.16 GAS VALVE - EVG**

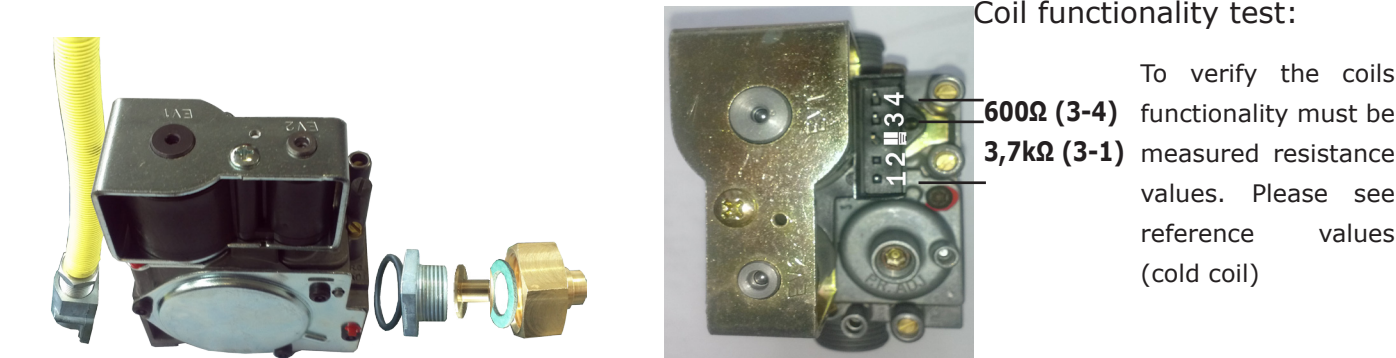

### 3.17 MOTORIZED DISCHARGING VALVE - MS



#### Automatic operations:

Cooking mode : valve open

Automatic washing mode : valve close

### 3.18 WASHING PUMP - PL



The washing pump working when the water discharge is closed and a fill of water is charged in the cavity. It's thermally protected and the reset is automatic when the temperature of the pump cool down.

### 3.19 DETERGENT PUMP - PD

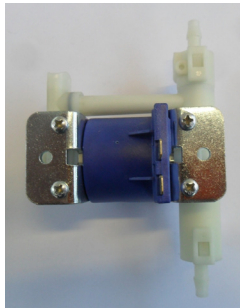

Detergent pump for the automatic washing system.

### 3.20 FLOWMETER WASHING SYSTEM



The flowmeter control the quantity of water is load during a washing cycle.

**3.21 BUTTERFLY VALVE - MV**

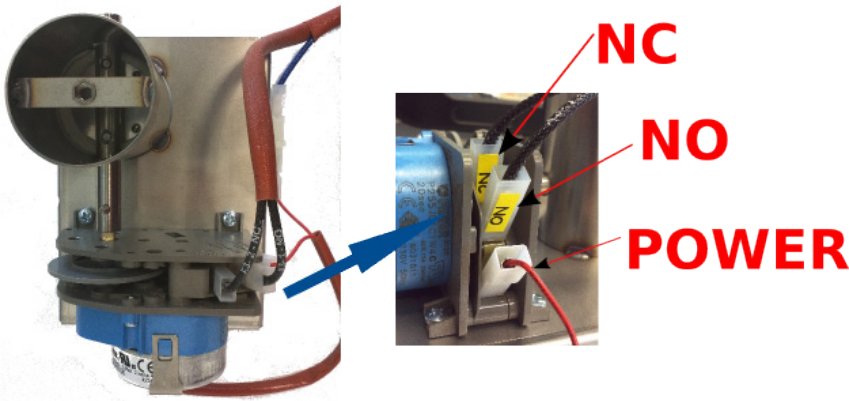

The butterfly valve open or close the air inlet to regulate the humidity in the cavity. It's normally closed when the oven is switch on in STOP mode. To correct CLOSE position is showed in the picture.

**4.0 GAS OVEN SETUP**

The oven is originally calibrated for functioning with the gas type specified during ordering. The type of gas for which the oven is adjusted is reported on the technical place on the appliance.

During testing, ascertain the factory calibrations carried out on the burners are appropriate for the specific installation type, by means of analysis of the gases produced by combustion (CO<sub>2</sub> and CO) and check of the thermal capacity.

The detected data must be recorded and become integrating part of the technical documentation of that appliance.

**4.1 COMBUSTION ANALISYS**

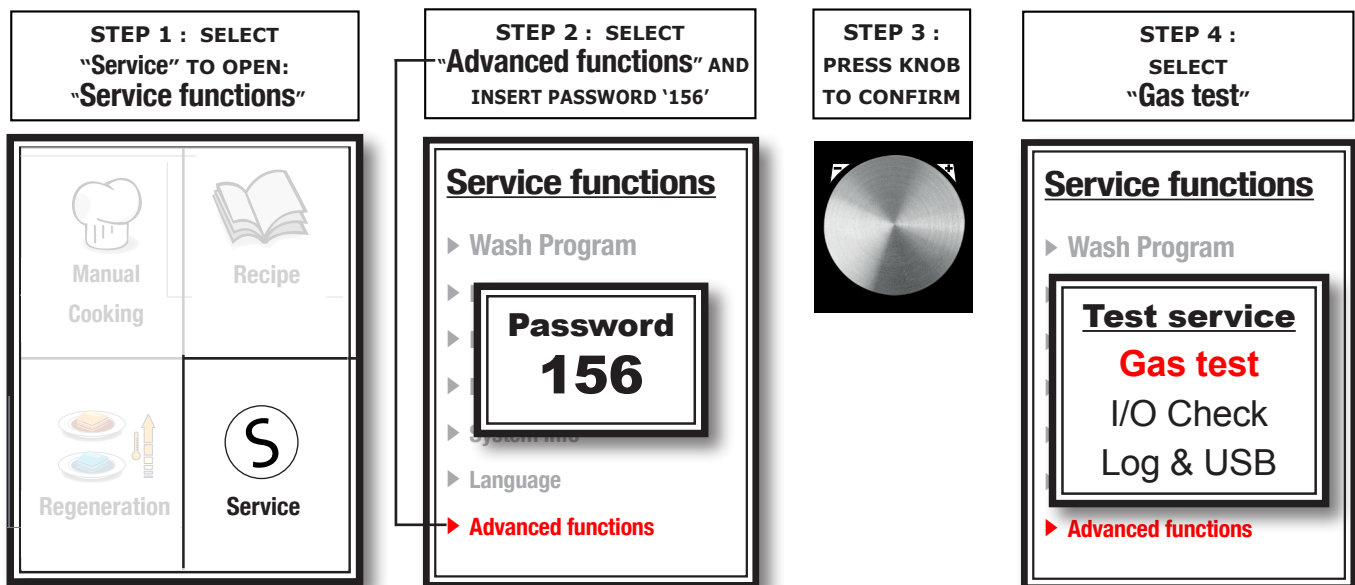

## 1. The gas test must be carried out with the door open.

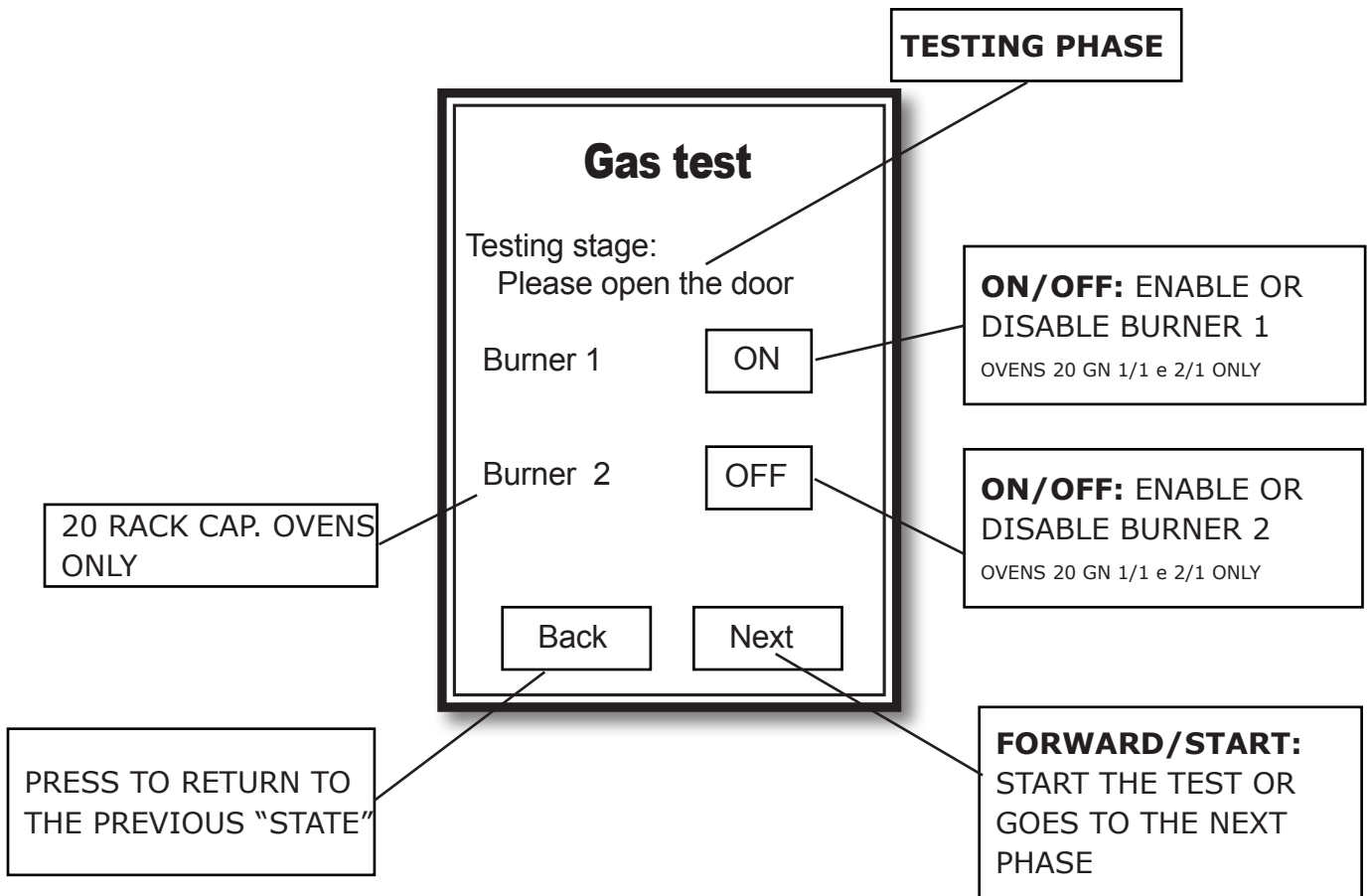

## 2. Starting gas test procedure:

After opening the oven door the testing procedure can be started by pressing the "NEXT" key.

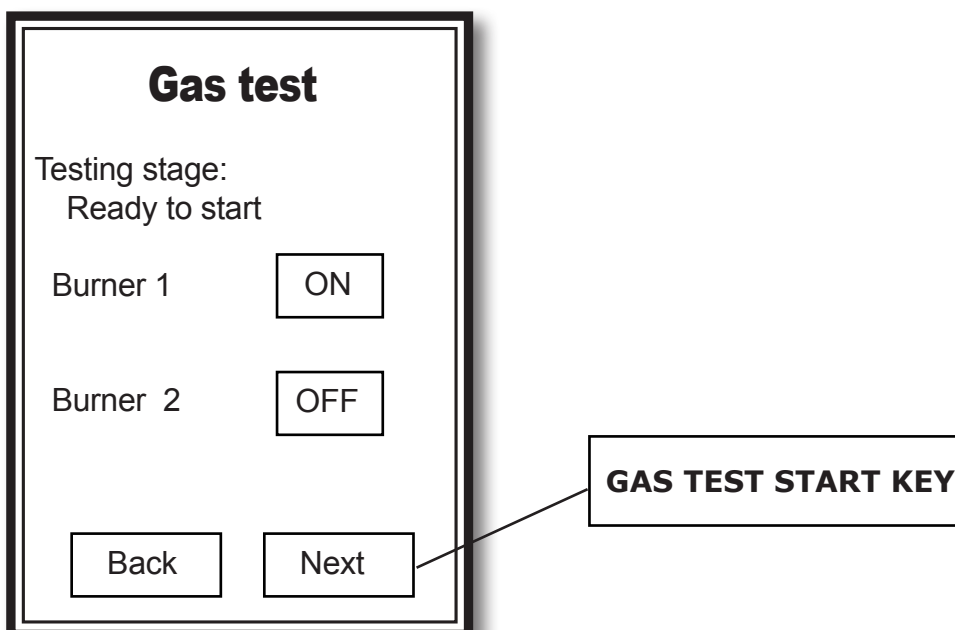

**3. Adjustment of burners to minimum and maximum power:**

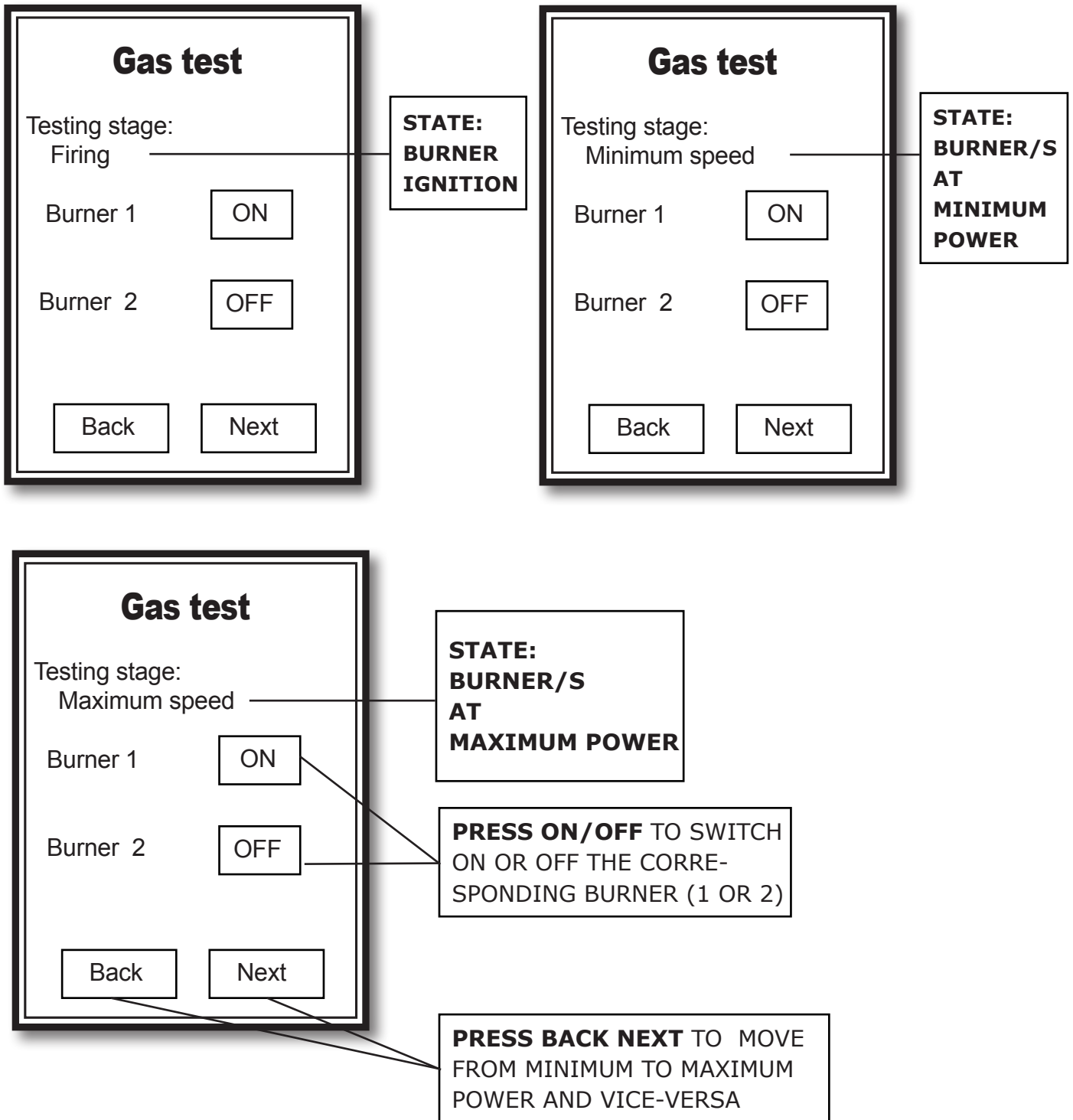

**To end the GAS test procedure press NEXT until exiting the main menu screen**

## 4.2 GAS REFERENCE TABLE

OVEN MODEL	ADJUSTEMENT						COMBUSTION VALUES		# BURNERS
	TYPE OF GAS	TYPE OF GAS TO MAKE REFERENCE FOR THERMAL CAPACIT	 NOZZLE 1/10 mm	ALTERNATIVE NOZZLES	POWER MAX	POWER MAX	CO2 REFERENCE MIN	CO2 REFERENCE MAX	
6 GN 1/1	NATURAL	G20	43	44	8	12	9,5 %	9,2 %	1
	LPG	G30 G31	35	34 - 36	8,5	12	11%-11,8% G31 - G30	10,7 %-11,3% G31 - G30	
6 GN 2/1	NATURAL	G20	43	44	16,5	20	9,6 %	9,6 %	1
	LPG	G30 G31	35	34 - 36	16,5	20	11,2%-11,5% G31 - G30	11,2%-11,5% G31 - G30	
10 GN 1/1	NATURAL	G20	44	45	13	19	9,8%	9,4%	1
	LPG	G30 G31	35	34 - 36	13,5	19	11,5%-11,8% G31 - G30	10,9%-11,5% G31 - G30	
10 GN 2/1	NATURAL	G20	44	45	22	27	9,8	10,2	1
	LPG	G30 G31	35	34 - 36	22	27	11,4%-11,7% G31 - G30	11,6%-11,9% G30 - G31	

## 4.3 SETTING IGNITION PROBES AND DETECTING FLAME PROBE

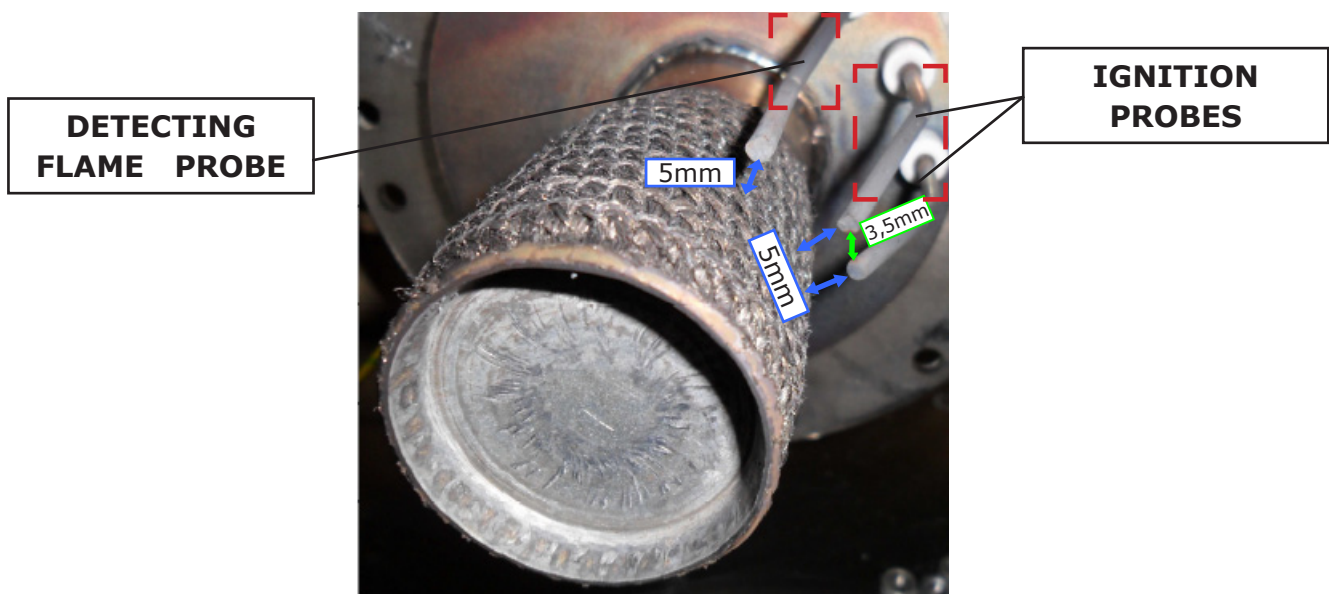

**4.4 GAS CHANGE PROCEDURE**

1. Replace nozzle (injector) on gas valve



2. Insert the USB drive in the oven USB port (the PARAMETERS FILE loaded is specific for each oven model and gas setting: FILE "PARXXX.CSV").



**3.1.a UPLOAD GAS PARAMETERS** Ver 250 : OLD BOARD

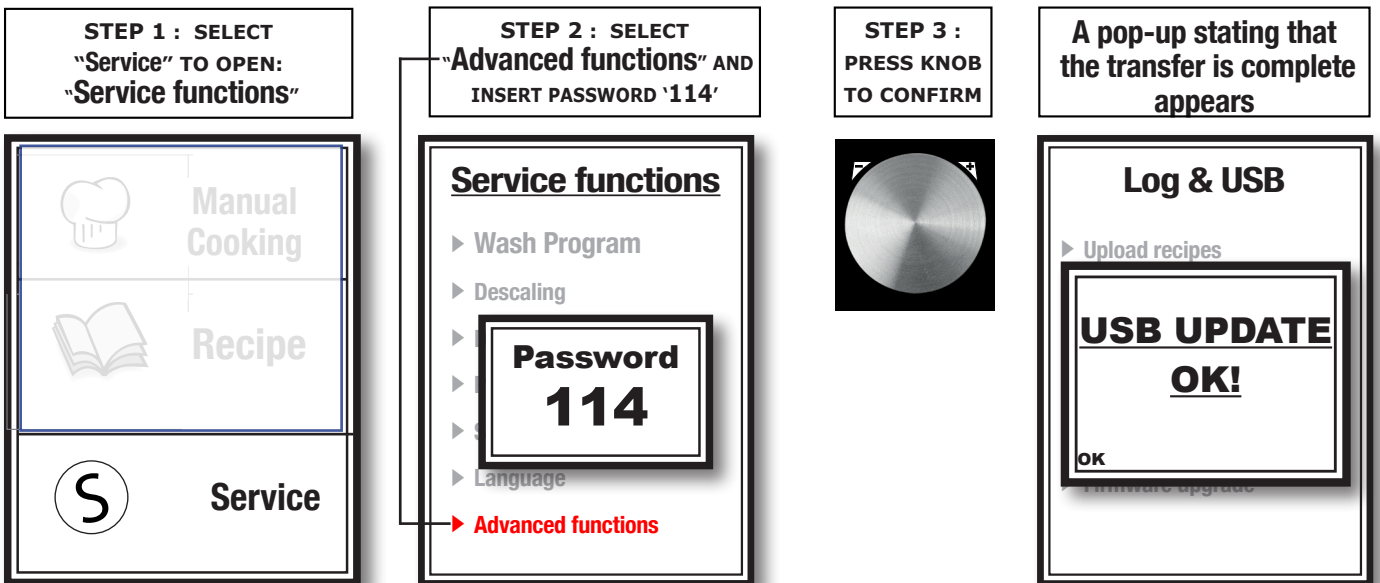

**3.1.b UPLOAD GAS PARAMETERS** **Ver 344 : NEW BOARD**

**STEP 1 : SELECT "Service" TO OPEN: "Service functions"**

**STEP 2 : SELECT "Advanced functions" AND INSERT PASSWORD '156'**

**STEP 3 : PRESS KNOB TO CONFIRM**



**Service functions**

- ▶ Wash Program
- ▶ **Password 156**
- ▶ System info
- ▶ Language
- ▶ **Advanced functions**

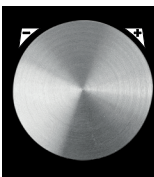

**STEP 4 : SELECT "Log & USB"**

**STEP 5 : SELECT "Upload parameters"**

**A pop-up stating that the transfer is complete appears**

**ERROR pop-up appears if no file or wrong file**

**Service functions**

- ▶ Wash Program
- ▶ **Test service**
- Gas test
- I/O Check
- Log & USB**
- ▶ Advanced functions

**Log & USB**

- ▶ Upload recipes
- ▶ Download recipes
- ▶ Download HACCP log
- ▶ Download parameters
- ▶ **Upload parameters**
- ▶ Firmware upgrade

**Log & USB**

**USB UPDATE OK!**

**Log & USB**

**ERROR!**

**4.1 ACTIVATE GAS TEST PROCEDURE**

**STEP 1 : SELECT "Service" TO OPEN: "Service functions"**

**STEP 2 : SELECT "Advanced functions" AND INSERT PASSWORD '156'**

**STEP 3 : PRESS KNOB TO CONFIRM**

**STEP 4 : SELECT "Gas test"**



**Service functions**

- ▶ Wash Program
- ▶ **Password 156**
- ▶ System info
- ▶ Language
- ▶ **Advanced functions**

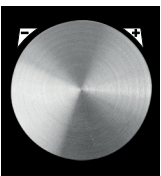

**Service functions**

- ▶ Wash Program
- ▶ **Test service**
- Gas test**
- I/O Check
- Log & USB
- ▶ Advanced functions

5. Check the combustion and, if necessary, change the nozzle.



4.5.1

FIXING THE BURNER TO THE EXCHANGER: GASKET SEQUENCE

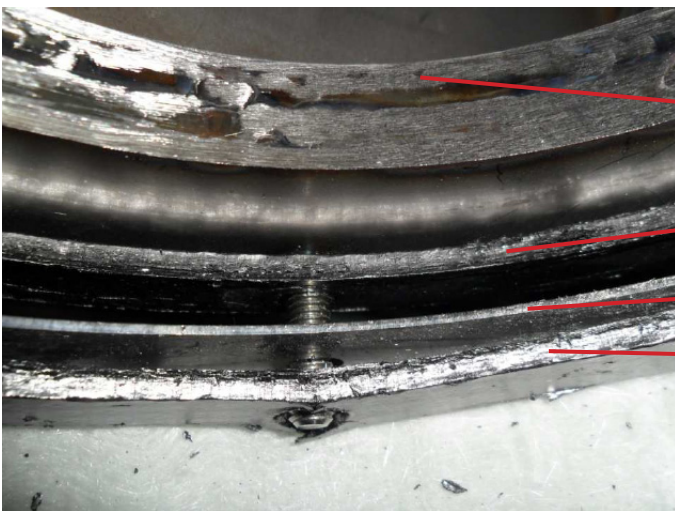
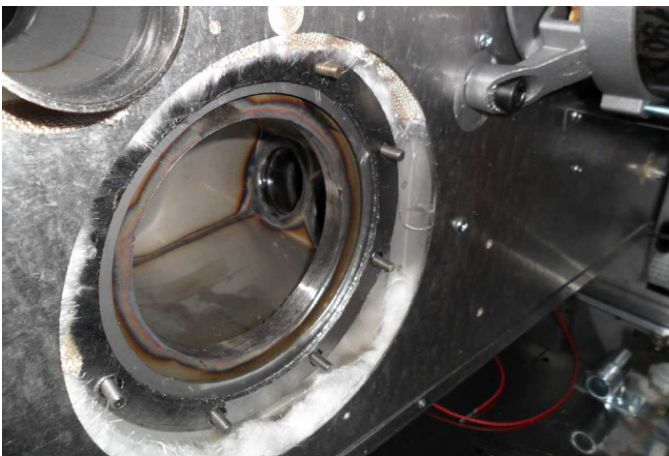

EXCHANGER  
 GRAPHITE GASKET  
 OVEN CHAMBER  
 GRAPHITE GASKET

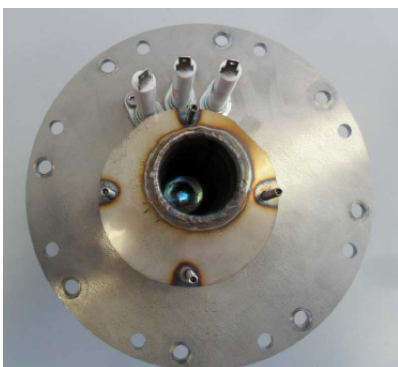

## 4.5.2

## FIXING THE BURNER TO THE EXCHANGER: NOTES

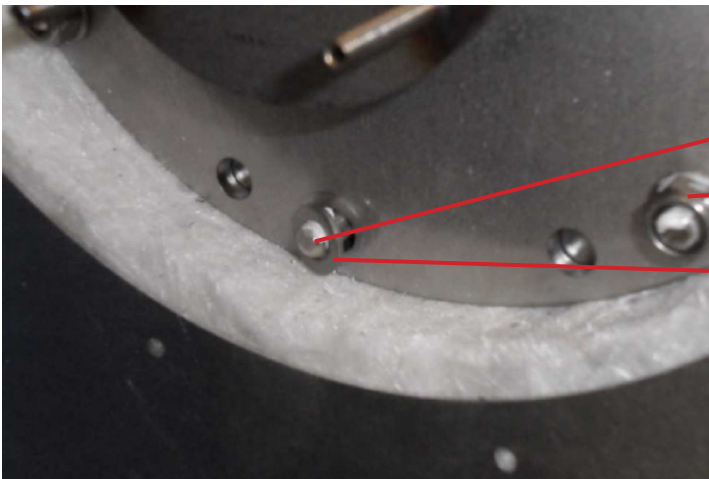
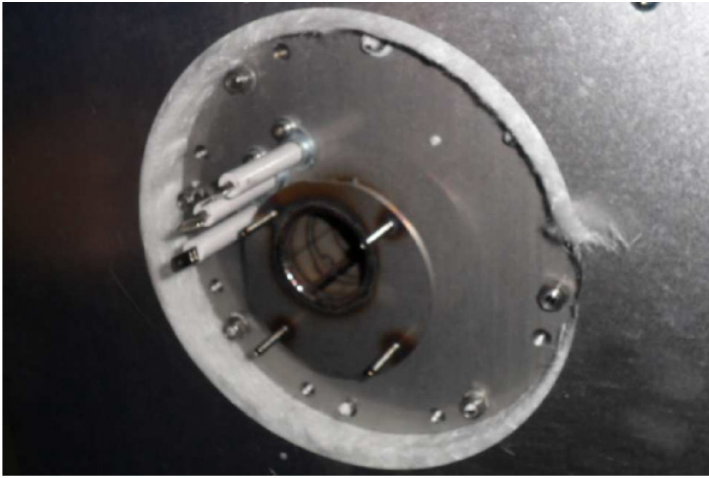

SPECIAL GREASE

SELF BLOCKING NUT M6

WASHER



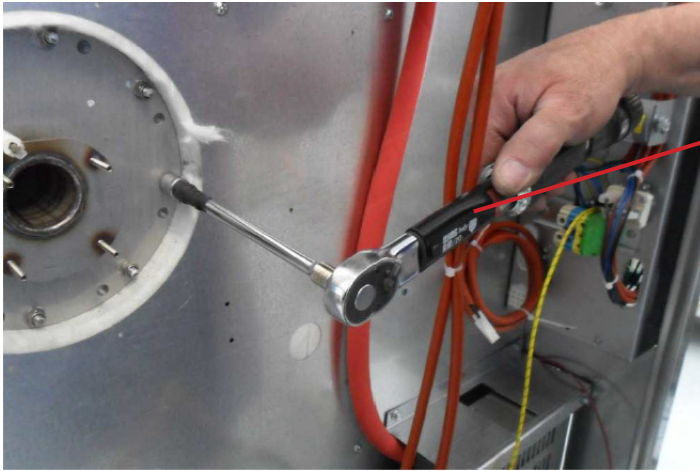

NUTS M6 MUST BE CLOSED BY USING A TORQUE WRENCH



SET TORQUE AT 6 N/m

**5.0 ELECTRONIC BOARDS AND CONFIGURATION**



**MAIN POWER BOARD**



**TOUCH BOARD**



**EXPANSION CARD**

## 5.1

## CONFIGURATION OF ELECTRONIC BOARDS SERIAL CONNECTION

## RULES OF SERIAL CONNECTION

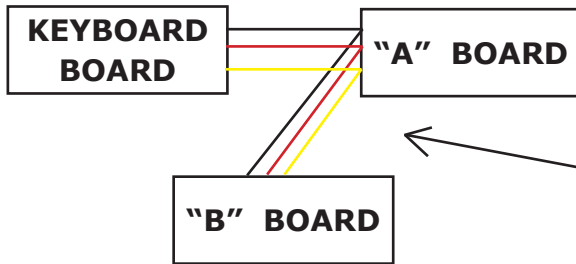

1. All electronic boards of the SteamBox ovens 'component panel' area communicate with the keyboard motherboard (touch or programmable) via **RS485 serial connection**

2. 'Keyboard' board is the main board and the operation configuration of other boards connected in serial depends on it.

3. The beginning and the end of the serial connection must always be **completed** by means of **dip-switch** activation

4. In case that more than one board of the same type are present in the system, these must be addressed in a **different** way, by using another **dip-switch**



## 485 SERIAL CONNECTION

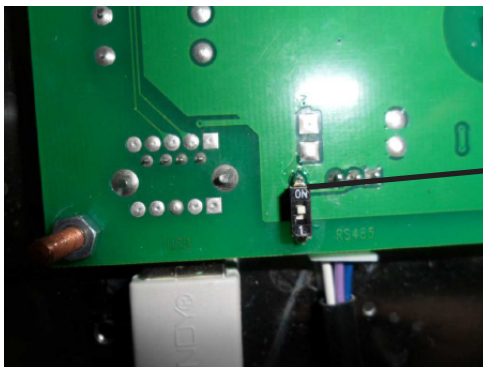

Keyboard board is always at the BEGINNING of the serial connection and so they must be **completed** by activating the corresponding DIP-SWITCH in **ON**

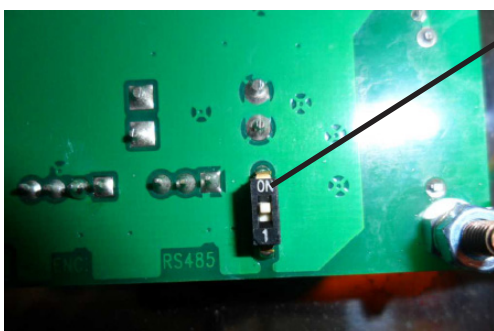

The type of serial connection termination must be **start:ON -OFF - OFF .....OFF - ON:end**. Therefore, the board at the end of the serial connection 'chain' **must be completed**.

PWM "8" BOARD TERMINATOR

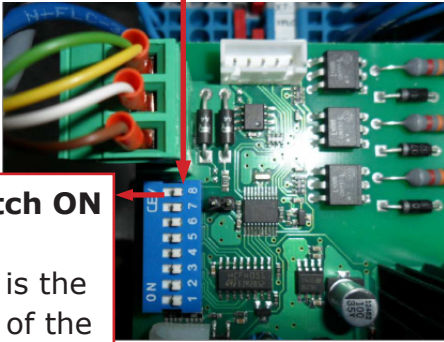

**Switch ON**  
if it is the end of the serial line

INVERTER BOARD TERMINATOR

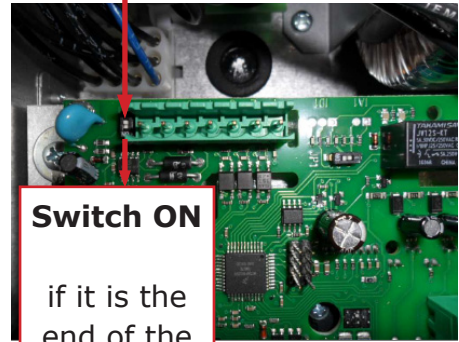

**Switch ON**  
if it is the end of the serial line

Address in different way in case there are more than one board of the same type:

PWM "6" BOARD ADDRESS

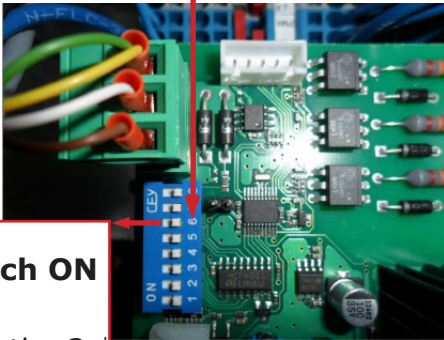

**Switch ON**  
if it is the 2<sup>nd</sup> board of the serial line of this type

INVERTER BOARD ADDRESS

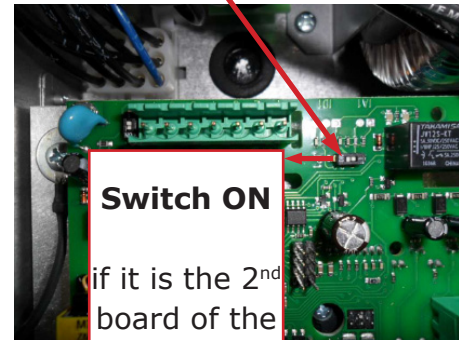

**Switch ON**  
if it is the 2<sup>nd</sup> board of the serial line of this type

## 5.2

## I/O CHECK

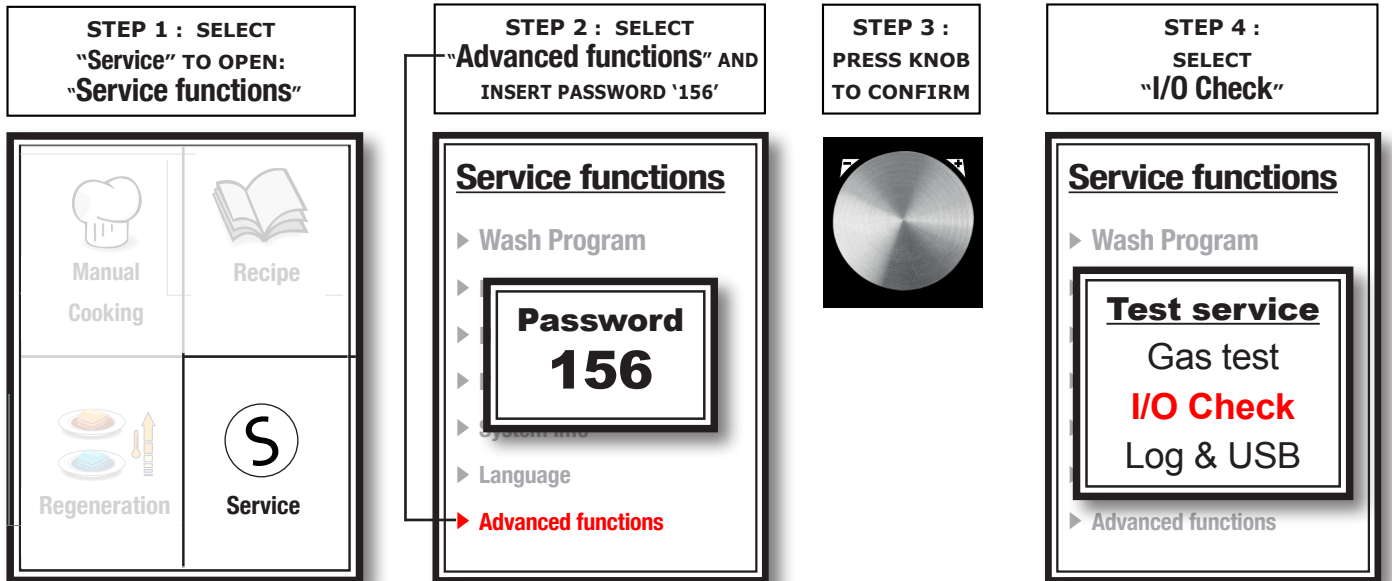

## 5.2.1

## I/O CHECK - PROBES

Identification	Probe	Clamp
<b>S1 – probe 1</b>	NTC on board - power card temperature (ALARM: Hi-Temp)	---
S2 – probe 2	//	//
<b>S3 – probe 3</b>	CORE thermocouple J	14 – 15
S4 – probe 4	FREE	12 – 13
<b>S5 – probe 5</b>	cavity thermocouple J	10 – 11
S6 – probe 6	FREE	20 – 21
<b>S7 – probe 7</b>	Humidity probe 2 thermocouple J (ALARM: PROBE 5)	18 – 19
<b>S8 – probe 8</b>	Humidity probe thermocouple J (ALARM : PROBE 4 )	16 – 17
S9 – probe 9	//	//
S10 – probe 10	//	//
S11 – probe 11	//	//
S12 – probe 12	//	//

## 5.2.2 I/O CHECK - DIGITAL INPUTS

Identification	Input	Clamp
<b>I1 – Motor safety 1</b>	Motor 1 thermal protection (230Vac) <b>0= open/faulty</b> <b>1= close/active</b>	40 – 41
<b>I2 – Motor safety 2 (2 motors ovens only)</b>	Motor 2 thermal protection (230Vac) <b>0= open/faulty</b> <b>1= close/active</b>	39 – 41
<b>I3 – Safety thermost</b>	Chamber safety (230Vac)	38 – 41
<b>I4 – Alarm burner 1</b>	Burner 1 block (230Vac)	36 – 37
<b>I5 – Alarm burner 2</b>	Burner 2 block (230Vac)	35 – 37
<b>I7 – Door switch</b>	Door input <b>1 = door open</b> <b>0 = door closed</b>	6 – 9
<b>I8 – Air safety 1</b>	Air flow inlet 1 <b>1 = contact open</b> <b>0 = close if vacuum</b>	7 – 9
<b>I9 – Air safety 2</b>	Air flow inlet 2 <b>1 = contact open</b> <b>0 = close if vacuum</b>	8 – 9
<b>I10 – Boiler level</b>	Level 1 input <b>1 = boiler empty</b> <b>0 = boiler full</b>	44 – 45
I11 – L2	not used	43 – 45
I12 – L3	not used	42 – 45
I13	not used	60 – 61

### example: BOILER TEST

- 1)** Make sure that boiler is empty verifying I10 = 1 or activate R17 for almost 15 seconds to drain water from the boiler
- 2)** Activate R18 to load boiler water
- 3)** Check I10: in almost 60 second boiler level will change to ---> =0 boiler full. Boiler level must be '0' and has not to change itself, otherwise there is a leakage into boiler or solenoid valve.  
If the level does not change please verify water loading system (water inlet , lime,obstructions..etc ) and check the functionality of level control system (probe cleaning, control board `ok`)
- 4)** Activate R20 and verify Amperage with a clamp meter (boiler 6/10 gn1/1, 6 gn2/1 = 4,3A ; boiler 20 gn1/1, 10/20 gn2/1 = 10.8A)

### 5.2.3 I/O CHECK - DIGITAL OUTPUTS

In this section one can pilot some utilities manually by positioning the cursor on the desired utility and pressing the encoder key. By pressing the encoder key again the utility is deactivated.

Identification	Relay	Notes	Clamp
<b>R1: Resist 1</b>	Chamber 1	Electric oven actionable only re- mains active for max. 10s. The fan is activated as well.	33 – 34
<b>R2: Resist 1+2</b>	Chamber 2	Electric oven actionable only remains active for max. 10s. The fan is activat- ed as well.	32 – 34
<b>R4: Humidity disch.</b>	Butterfly valve	Commands opening and closing. Command active only with discharge stopped. Positioning change occurred display.	29 – 31
<b>R5: Hand shower</b>	Shower electrovalve	door open : active door closed : inactive (to protect hand shower hose from over pressure)	28 - 31
<b>R9: Steam kill</b>	Quencing electrovalve		23 – 26
<b>R10: Humidif</b>	Humidifier		22 – 26
<b>R11: Discharge</b>	Chamber discharge motorised valve		46-47-50
<b>R12: Washing water</b>	Load solenoid valve washing water		48 – 50
<b>R13: Washing pump</b>	Washing pump		49 – 50
<b>R17: Boiler discharg</b>	Boiler Discharge solenoid valve		54 – 57
<b>R18: Boiler water</b>	Boiler Load solenoid valve		55 – 57
<b>R19: Detergent</b>	Pump Detergent load	0.85 fl oz/sec (0.025 liter/sec)	56 – 57
<b>R20: Boiler resist.</b>	Boiler resistances		58 – 59
<b>H1: Pulse counter 600 Pulses = 2.1 pt lqd (1liter)</b>	Washing water liter counter	Increases its value if water from the R12 solenoid valve is loaded	JST – J5

**5.3 HACCP RECORDING (TOUCH BOARD)**



If printouts are enabled through the **EnHACCP** parameter when "start" is pressed on the oven, it begins recording the cooking. The cooking data are: time, chamber temperature and, if present, core probe temperature. Recording is done at the following times:

- At start. At automatic pre-heating as indicated.
- Switching from pre-heating to cooking (when the door is opened and closed at the end of pre-heating).
- At every phase change.
- After the number of minutes since the last recording, as set in the **TimeStHACCP** parameter.
- In cooking mode with core probe: when the core temperature since the last recording differs by the number of degrees set in the parameter **DeltaTHACCP**.
- In "timed" cooking when the chamber temperature since the last recording differs by the number of degrees set in the parameter **DeltaTHACCP**.
- When the oven stops or at the end of the cooking program.

**5.3.1 COOKING LOG MEMORISATION**

The printout data are logged in a different file for each day. All of the cooking cycles performed in the same day (taking into consideration the start time) are saved progressively in the same file. The name of the file will be "yy\_mm\_dd.log where yy = year, mm = month and dd = day. The file is in text format.

**5.3.2 PRINTOUT EXAMPLE**

\*\*\*\*\* Separator

```
Start Log 10/09/2010 15:23 Start
Roast Program name
Core Chamber Time Column Name
Phase 1 Phase no.
15:23:32 084 --- Date
15:23:35 084 ---
End Log End
```

**5.3.3 HACCP PARAMETERS**

**P500 - HACCP enabling:**

- 0 = disabled (default)
- 1 = enabled only for probe cooking (**WITH** USB pen-drive connected)
- 2 = enabled for all cooking (**WITH** USB pen-drive connected)

ONLY: **Ver 344 : NEW BOARD**

- 3 = enabled only for probe cooking (**WITHOUT** USB pen-drive connected,download after)
- 4 = enabled for all cooking (**WITHOUT** USB pen-drive connected,download after)

**P501** = Maximum time between HACCP data (1-20 minutes): default '5'

**P502** = Maximum temperature difference (at core if cooking with probe or chamber if timed cooking between HACCP data saves (1-20° C): default '5'

**5.3.4** DOWNLOAD HACCP LOG--->USB **Ver 344 : NEW BOARD**

**STEP 1 :**  
INSERT A EMPTY  
USB PENDRIVE



**STEP 2 : SELECT**  
"Service" TO OPEN:  
"Service functions"

 Manual Cooking	 Recipe
 Regeneration	 Service

**STEP 3 :**  
SELECT  
"USB"

**Service functions**

- ▶ Date and Time
- ▶ Parameters
- ▶ System info
- ▶ Language
- ▶ Advanced functions
- ▶ Wash log - Download
- ▶ **USB**

**STEP 4 :**  
SELECT  
"Download log HACCP"

**USB**

- ▶ **Download log HACCP**
- ▶ Upload recipes
- ▶ Download recipes
- ▶ Firmware upgrade

A pop-up stating that the transfer is complete appears

**USB**

**USB UPDATE  
OK!**

**5.4** WASH LOG - DOWNLOAD - ERASE **Ver 344 : NEW BOARD**

**STEP 1 :**  
INSERT A EMPTY  
USB PENDRIVE



**STEP 2 : SELECT**  
"Service" TO OPEN:  
"Service functions"

 Manual Cooking	 Recipe
 Regeneration	 Service

**STEP 3 :**  
SELECT  
"Wash log - Download"

**Service functions**

- ▶ Date and Time
- ▶ Parameters
- ▶ System info
- ▶ Language
- ▶ Advanced functions
- ▶ **Wash log - Download**
- ▶ USB

**Wash log**

Soft - 18/07/14 - 11:11  
Hard - 20/07/14 - 19:15

AVAILABLE ONLY IF THE  
PASSWORD '156'  
WAS INSERTED BEFORE





**Wash log**

**USB UPDATE  
OK!**

**Wash log**

Soft - 18/07/14 - 11:11  
Hard - 20/07/14 - 19:15

**Erase LOG?**

Yes No

**5.5** UPLOAD - DOWNLOAD RECIPES

**5.5.1** UPLOAD RECIPES

**STEP 1 : INSERT USB PENDRIVE WITH RECIPES FILE "GRECIPE.CSV"**



**STEP 2 : SELECT "Service" TO OPEN: "Service functions"**



**STEP 3 : SELECT "USB"**

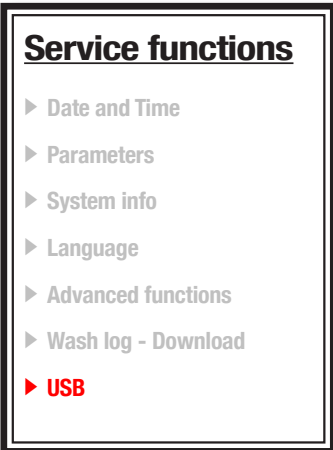

**STEP 4 : SELECT "Upload recipes"**

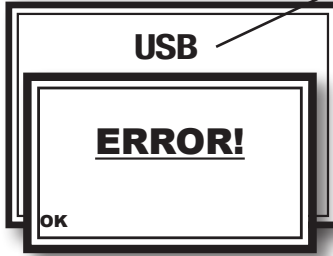
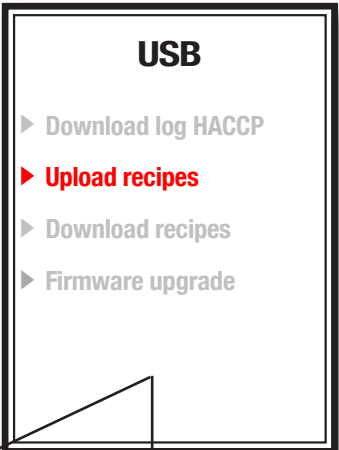

**ERROR pop-up appears if no file or wrong file**

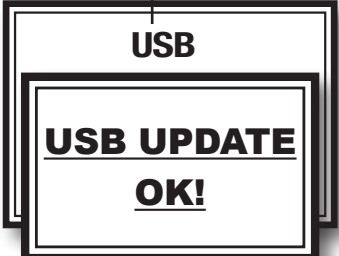

**A pop-up stating that the transfer is complete appears**

**5.5.2** DOWNLOAD RECIPES

**STEP 1 : INSERT A EMPTY USB PENDRIVE**



**STEP 2 : SELECT "Service" TO OPEN: "Service functions"**



**STEP 3 : SELECT "USB"**

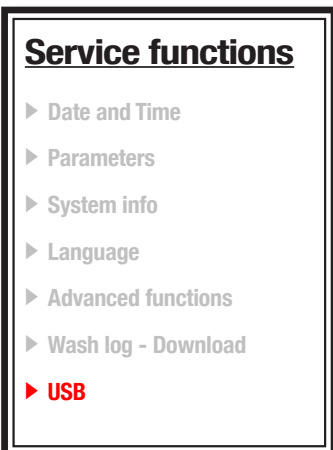

**STEP 4 : SELECT "Download recipes"**



5.6

WASH LOG - DOWNLOAD/ERASE

**Ver 344 : NEW BOARD**

**STEP 1 : INSERT  
A EMPTY USB  
PENDRIVE**



**STEP 2 : SELECT  
"Service" TO OPEN:  
"Service functions"**



**STEP 3 : SELECT  
"Advanced functions" AND  
INSERT PASSWORD '156'**



**STEP 4 :  
PRESS KNOB  
TO CONFIRM**

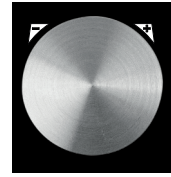

**STEP 5 :  
SELECT  
"Log & USB"**

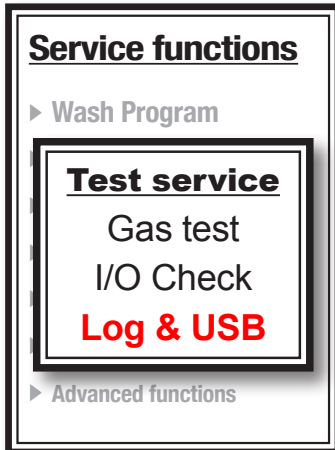

**STEP 6 :  
SELECT  
"Wash log - Download"**

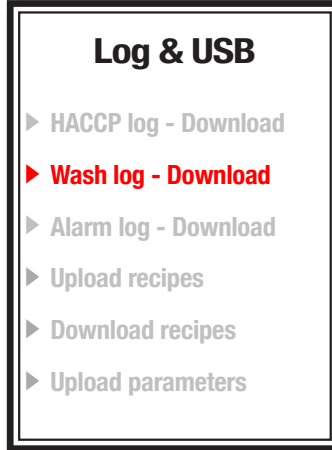

**STEP 7 :  
SELECT  
"Wash log - Download"**

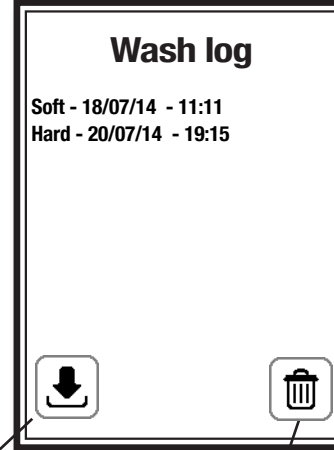

**USB**

**USB UPDATE  
OK!**

**A pop-up stating that  
the transfer is complete  
appears**

**Wash log**

Soft - 18/07/14 - 11:11  
Hard - 20/07/14 - 19:15

**Erase LOG?  
Yes No**

**STEP 8 :  
SELECT AND CONFIRM  
PRESSING KNOB**

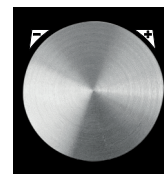

## 5.7

## ALARMS DESCRIPTION

In case of alarm the identifying name of the alarm in progress appears on temperature display and on time display. The following alarms are managed:

Name	Description	Actions	SOLUTION
<b>Chamber probe</b>	Chamber probe error	Cooking block, automatic restore.	Replace chamber probe.
<b>Core probe</b>	Core probe error	Manual restore.	Replace core probe.
<b>GAS</b>	Gas burner block	Cooking block, manual restore.	Press manual restore. (encoder button for 1 Second)
<b>GAS 2</b>	Gas second burner block.	Cooking block, manual restore.	Press manual restore. (encoder button for 1 Second)
<b>Motor safety</b>	Motor Alarm	Cooking block, automatic re-arm	If continuous, contact after-sales assistance.
<b>Inverter code:</b>	Motor Inverter Alarm	Cooking block, automatic re-arm	Check the inverter error table at page 36.
<b>Chamber safety</b>	Chamber safety thermal.	Cooking block, manual re-arm.	Check the safety thermostat (par. 3.8 page 12).
<b>PWM</b>	PWM board error (communication timeout or problems on fan speed)	Cooking block.	Check 24 volt power supply,pwm, connection cables and fan blower
<b>PWM 2</b>	PWM second board error (communication timeout or problems on fan speed)	Cooking block.	Check 24 volt power supply,pwm, connection cables and fan blower
<b>Air Flow</b>	Air capacity on gas burner alarm	Cooking block, manual restore.	Check obstructions to combustion fumes exhaust flue, check pressostat at the end of the gas blower.
<b>Air Flow 2</b>	Air capacity on second gas burner alarm	Cooking block, manual restore.	Check obstructions to combustion fumes exhaust flue, otherwise contact after-sales assistance.
<b>Hi temp</b>	Technical compartment temperature too high.	Cooking is blocked, automatic restore.	Check oven's perimeter ventilation, the lower air filter (pag. 46) and the correct functioning of the cooling fans of the components.
<b>No water</b>	No water for the production of steam.	Cooking is blocked, automatic restore.	Check connection to water duct, the boiler and water presostat. Check opening of the shut-off cook.
<b>No water flowmeter</b>	Washing flowmeter alarm	Washing is blocked.	Check connection to water duct and opening of the shut-off cook Check the flowmeter.
<b>Com PWM</b>	PWM board communication error	Cooking block.	Check cleanliness of the upper fan blower and fan power connection. Remove power and give back.
<b>Com PWM2</b>	PWM2 board communication error	Cooking block.	Check cleanliness of the lower fan blower and fan power connection. Remove power and give back.
<b>Communi-cation</b>	Main board communication error	Cooking block.	Remove power and then give back. If continuous, contact after-sales assistance.
<b>No drain</b>	Boiler water did not drain correctly	Cooking block.	Remove power and then give back. Check cleanliness and operation of the boiler diascharge valve.Check te boiler.
<b>Power fail</b>	Electrical power failure	Cooking block.	Press encoder button for 1 Second.
<b>Probe 4</b>	Humidity control probe 4 alarm	Cooking block.	Replace humidity probe 4
<b>Probe 5</b>	Humidity control probe 5 alarm	Cooking block.	Replace humidity probe 5

5.8

ALARM LOG - DOWNLOAD/ERASE

**Ver 344 : NEW BOARD**

**STEP 1 : INSERT  
A EMPTY USB  
PENDRIVE**



**STEP 2 : SELECT  
"Service" TO OPEN:  
"Service functions"**



**STEP 3 : SELECT  
"Advanced functions" AND  
INSERT PASSWORD '156'**

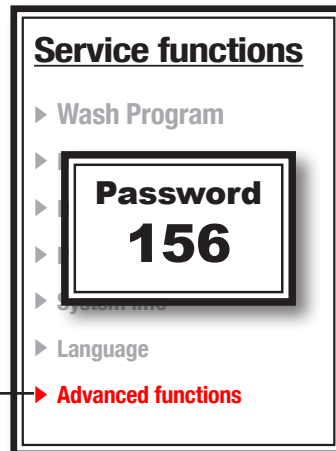

**STEP 4 :  
PRESS KNOB  
TO CONFIRM**

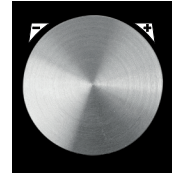

**STEP 5 :  
SELECT  
"Log & USB"**

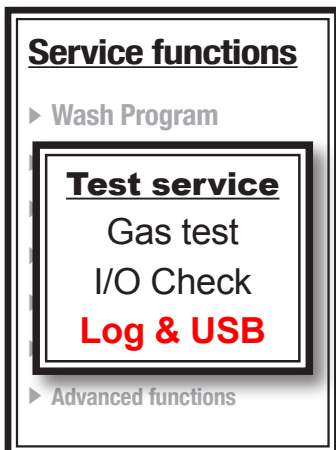

**STEP 6 :  
SELECT  
"Wash log - Download"**

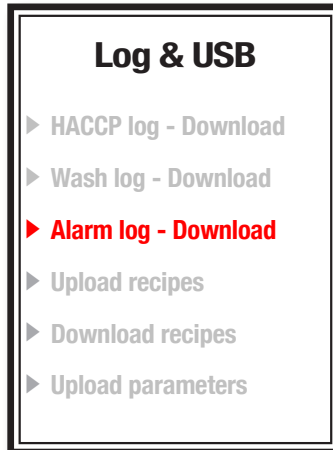

**STEP 7 :  
SELECT  
"Alarm log - Download"**



**USB**

**USB UPDATE  
OK!**

**A pop-up stating that  
the transfer is complete  
appears**

**Alarm log**

18/07/14 11:11  
E03 Inverter code: 08

**Erase LOG?  
Yes No**

**STEP 8 :  
SELECT AND CONFIRM  
PRESSING KNOB**

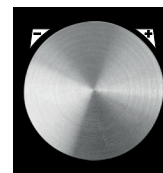

**5.9 SYSTEM INFO MENU**

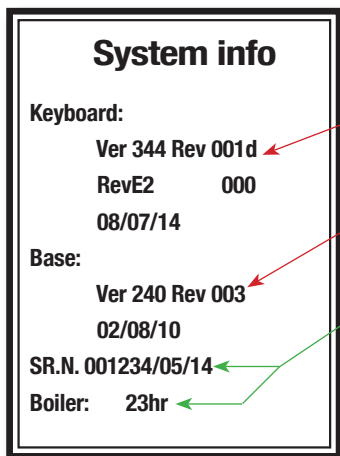

A page appears showing:
   
Keyboard firmware version: **Ver 344 : NEW BOARD**
  
**Ver 250 : OLD BOARD**
  
Base firmware version.

The oven serial number and the boiler operating hours (after the last descaling) are also given.
   
If the advanced services menu has been previously accessed by introducing the line end inspection password "956", by pressing the touch screen, access the oven serial number setting menu, otherwise go back to the service menu.

**5.10 INVERTER ALARM SIGNAL DIAGNOSTIC**

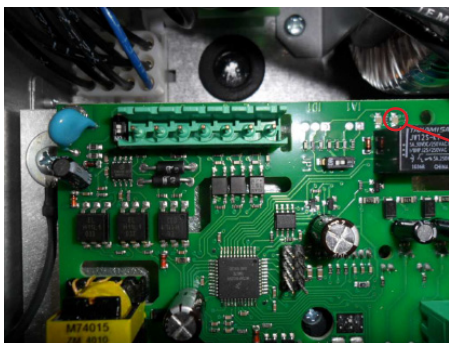



In case the oven main board signals an **INVERTER** alarm (or **Inv** on programmable version) can open the panel compartment to detect the number of 'flashes' indicated by the **RED LED**,
   
**(code error appear on display)**

The type of flashes sequence is: 1.5s pause followed by 0.5s flash 0,5s pause.
   
**ERROR CODIFICATION (code number = number of flashes):**

- code 1:** Error inside the Inverter. Disconnect the power supply of the oven and power it again, if the inverter must be replaced.
- code 2:** Failure on the motor (short), overcharged, or blocked motor. Perhaps the motor has some internal problems or something has blocked it.
- code 3:** The dissipator temperature of the inverter is too high: verify the ventilation of the technical compartment.
- code 4:** Error inside the Inverter. Disconnect the power supply of the oven and power it again, if the inverter must be replaced.
- code 5:** Inverter parameterization error. Disconnect the power supply of the oven and power it again, if the inverter must be replaced.
- code 6:** The motor is overcharged or blocked: ensure if it can be rotated in vain.
- code 7:** The motor presents little connection with the burnt or removed inverter. A failure could have occurred inside the winding
- code 8 :** Inverter communication error: verify the serial connection and RS485 connection configuration (also verify the inverter power supply : green led ON)

## 5.11

## TECHNICAL PARAMETERS

<b>STEP 1 : SELECT "Service" TO OPEN: "Service functions"</b>	<b>STEP 2 : SELECT "Parameters"</b>	<b>STEP 3 : INSERT PASSWORD '156'</b>	<b>STEP 4 : PRESS KNOB TO CONFIRM</b>
	<p><b>Service functions</b></p> <ul style="list-style-type: none"> <li>▶ Wash Program</li> <li>▶ Descaling</li> <li>▶ Date and Time</li> <li>▶ <b>Parameters</b></li> <li>▶ System info</li> <li>▶ Language</li> <li>▶ Advanced functions</li> </ul>	<p><b>Service functions</b></p> <ul style="list-style-type: none"> <li>▶ Wash Program</li> <li>▶ <b>Password</b></li> <li>▶ <b>156</b></li> <li>▶ System info</li> <li>▶ Language</li> <li>▶ Advanced functions</li> </ul>	

**P5 = Activation time cooking chamber lighting (0 – 255 seconds):**

- default '45'. 254 = light ON during cooking

**P14 = External buzzer activation:**

- 0 = deactivated (the buzzer on the keyboard works, in this case the external buzzer MUST be removed physically)
- 1-2 = activated

**P15 = Screen saver:**

- 0 = screen saver deactivated
- 1-120 = delay time to activate (seconds)
- 121 - 240 = delay time to activate (0-120 seconds) but the touch screen shows the total remaining time to finish cooking cycle

**P18 = Date Type:**

- 0 = EU date
- 1 = US date

**P70 = Steam condensation enabling (Quencing):**

- 0 = deactivated
- 1 = activated (default)

**P75 = Condensation activation time (0 – 10) : default '6' (=60%)**

- 0% - 100% (0-10)

**P400 = Boiler descaling product reaction time (0 – 600 minutes) : default is '360'.**

- The default time is set for **vinegar**. If other faster descaling products are used you can, for example, decrease the value of this parameter.

**P404 = Stand-by time for "boiler descaling" warning (0 – 2000 hours) : default '250'**

- The default time is set for softened water.(approximately 5 TH). If water hardness is greater than 5-10 TH it is recommended to lower the value by **P404**. (For example: 20-25 hours for 20°f). **WATER SOFTENER IS ALWAYS RECOMMENDED**

**P500 - HACCP enabling:**

0 = disabled (default)

1 = enabled only for probe cooking (**WITH** USB pen-drive connected)

2 = enabled for all cooking (**WITH** USB pen-drive connected)

ONLY: **Ver 344 : NEW BOARD**

3 = enabled only for probe cooking (**WITHOUT** USB pen-drive connected,download after)

4 = enabled for all cooking (**WITHOUT** USB pen-drive connected,download after)

**P501** = Maximum time between HACCP data (1-20 minutes): default '5'

**P502** = Maximum temperature difference (at core if cooking with probe or chamber if timed cooking between HACCP data saves (1-20° C): default '5'

**P980** = DEMO Mode

0 = normal operation (oven)

1 = DEMO mode (showroom)

2 = DEMO mode (demo unit - demonstration panel)

3 = DEMO WASH mode (showroom/fair)

**To change the value of a parameter:**

1. Select the parameter by rotating the encoder knob.
2. Press the knob button to enter "parameter change" mode.
3. Rotate the encoder knob to change the value of the parameter.
4. Press the knob button to enter confirm the change.
5. Press the "esc" key to exit the "parameters" menu.

**5.12**

**FIRMWARE UPGRADE**

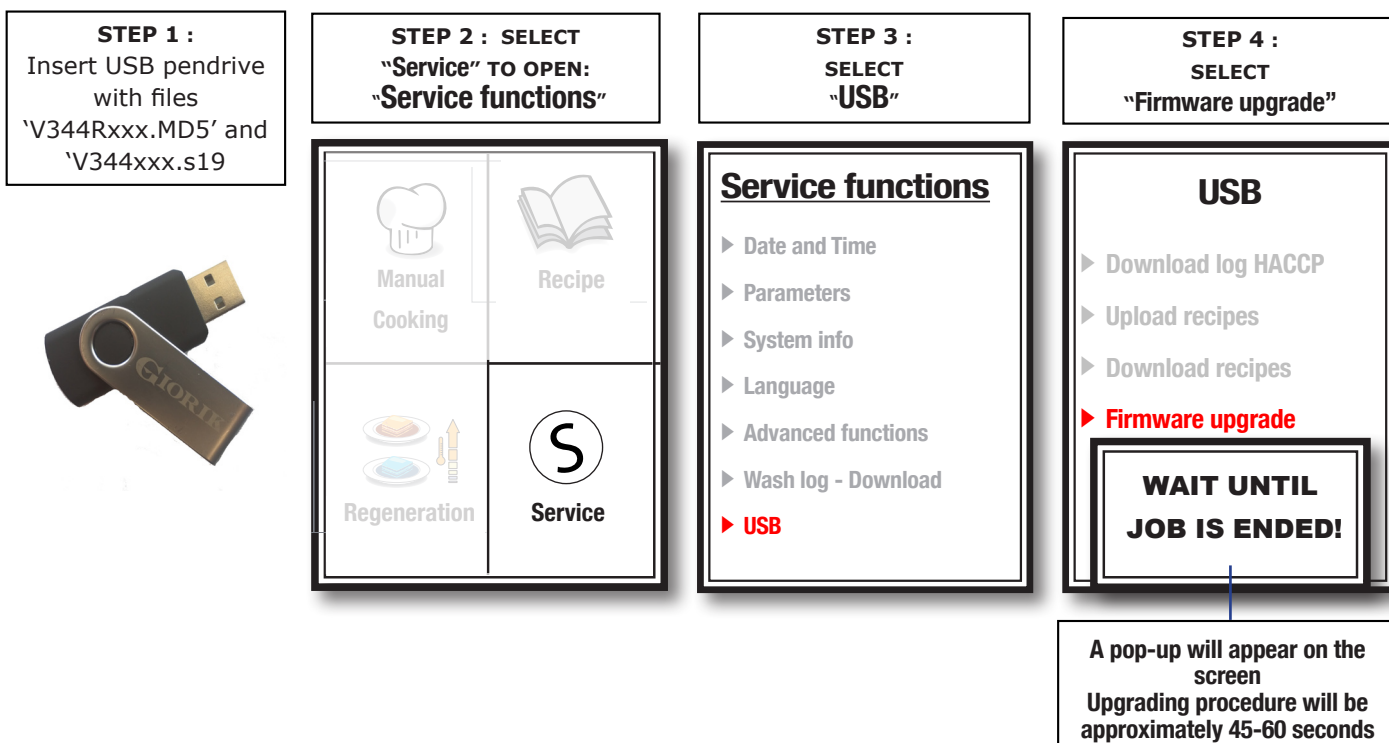

**5.13.1 UPLOAD NEW PARAMETERS**

**Ver 250 : OLD BOARD**

**STEP 1 : SELECT "Service" TO OPEN: "Service functions"**



**STEP 2 : SELECT "Advanced functions" AND INSERT PASSWORD '114'**

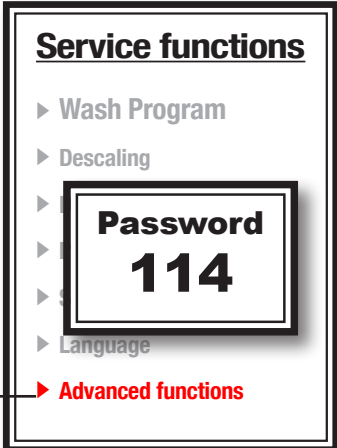

**STEP 3 : PRESS KNOB TO CONFIRM**

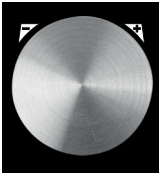

**A pop-up stating that the transfer is complete appears**



**5.13.2 DOWNLOAD PARAMETERS FROM THE OVEN**

**Ver 250 : OLD BOARD**

**STEP 1 : INSERT A EMPTY USB PENDRIVE**



**STEP 2 : SELECT "Service" TO OPEN: "Service functions"**



**STEP 3 : SELECT "Advanced functions" AND INSERT PASSWORD '12'**

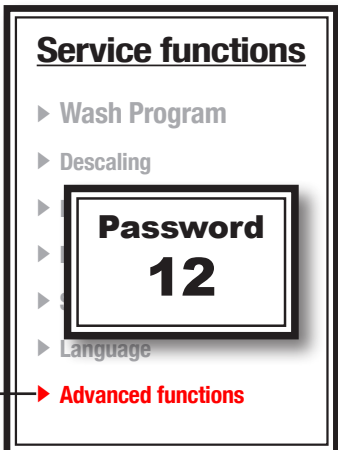

**STEP 4 : PRESS KNOB TO CONFIRM**

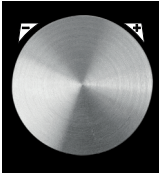

**STEP 5 : SELECT "Download recipes"**

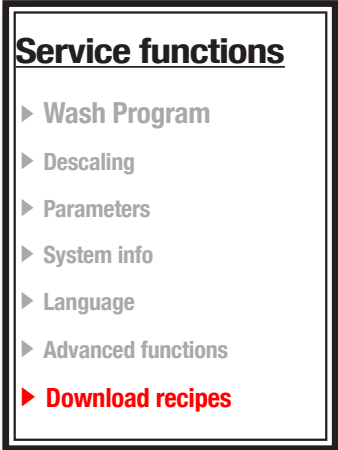

**STEP 6 : PRESS KNOB TO CONFIRM**

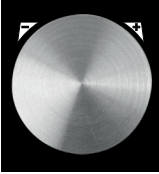

**A pop-up stating that the transfer is complete appears**



**5.13.3** **UPLOAD NEW PARAMETERS** **Ver 344 : NEW BOARD**

**Touch version**

**STEP 1 :**  
Insert USB pendrive  
with parameters file  
'parxxxx.csv'



**STEP 2 : SELECT**  
"Service" TO OPEN:  
"Service functions"



**STEP 3 : SELECT**  
"Advanced functions" AND  
INSERT PASSWORD '156'

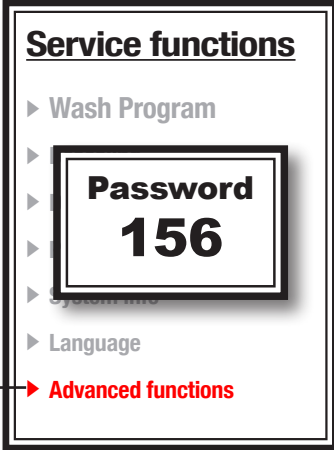

**STEP 4 :**  
PRESS KNOB  
TO CONFIRM

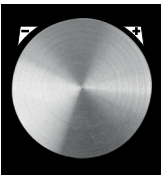

**STEP 5 :**  
SELECT  
"Log & USB"

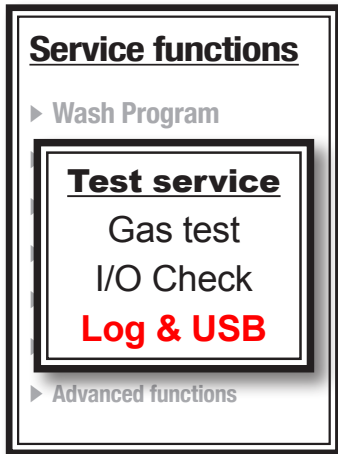

**STEP 6 :**  
SELECT  
"Upload parameters"

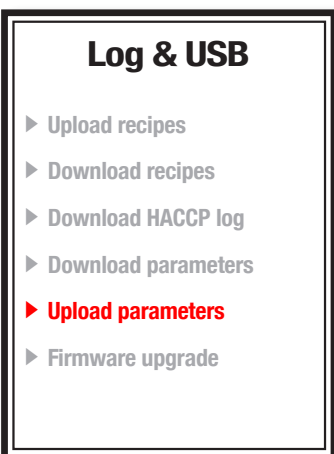

A pop-up stating that  
the transfer is complete  
appears



**ERROR**  
pop-up appears  
if no file or wrong file

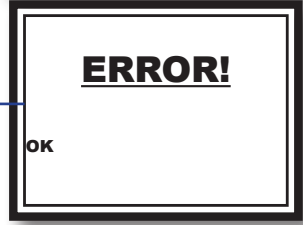

**5.13.4** DOWNLOAD PARAMETERS FROM THE OVEN **Ver 344 : NEW BOARD**

**STEP 1 :**  
Insert a EMPTY  
USB pendrive



**STEP 2 : SELECT**  
"Service" TO OPEN:  
"Service functions"



**STEP 3 : SELECT**  
"Advanced functions" AND  
INSERT PASSWORD '156'

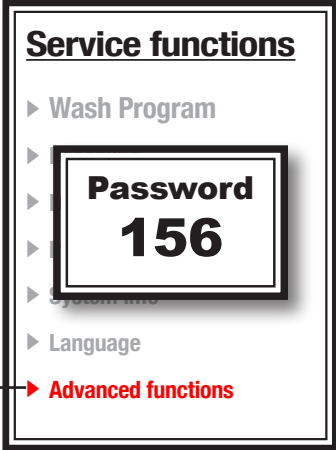

**STEP 4 :**  
PRESS KNOB  
TO CONFIRM

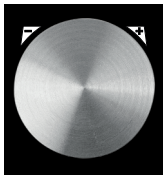

**STEP 5 :**  
SELECT  
"Log & USB"

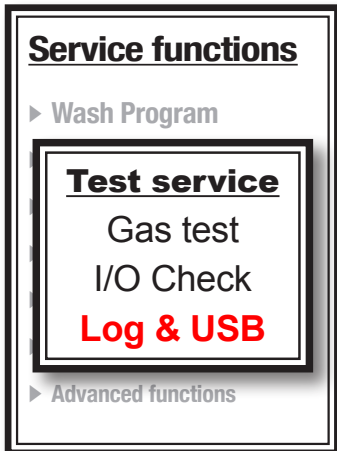

**STEP 6 :**  
SELECT  
"Download parameters"

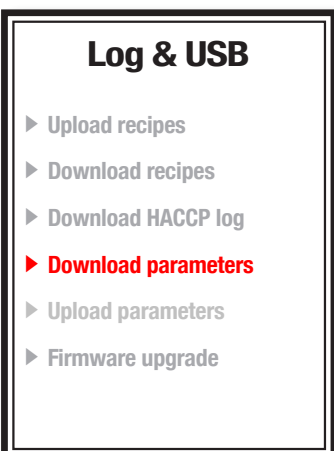

A pop-up stating that  
the transfer is complete  
appears



## 6.0 MAINTENANCE

### 6.1 BOILER DESCALING

Boiler descaling is activated by choosing the appropriate entry from the service menu:  
(Service – descaling) (insert part of the instructions manual)

At this point a sequence of pop-ups will appear that will guide the user until the end of the procedure. The procedure consists in the following phases:

#### 1 **Stand-by phase to confirm you want to carry out descaling:**

To start Boiler  
descaling press  
start

Press Esc to exit and return to the service menu

#### 2 **Boiler discharge phase:**

Descaling  
Wait for Boiler to  
empty

You must wait for the boiler to drain completely

Descaling  
Introduce 0.4 l of  
vinegar through  
the opening  
provided

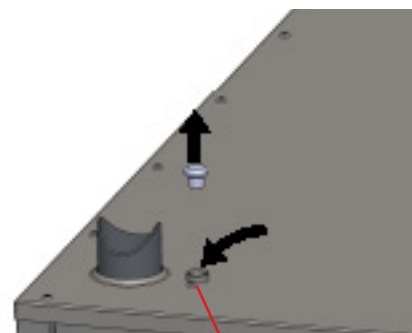

#### 3 **Reactant loading phase:**

As per instructions, insert the reactant in the boiler via the appropriate inlet

Descaling  
Continue waiting  
for:  
5:30 hours

#### 4 **Reactant working phase:**

There is an indication of how much is left to the end of the phase.

The duration of this phase depends on the value of parameter **P400** with default value: 360 minutes (6 Hours).

If you wish to use a different type of reactant you can change the value of this parameter. With the ON/OFF key you can interrupt the "stand-by with reactant" phase to go directly to the rinsing phase. In the event of no line power, upon reactivation the timer will restart counting from the residual time left.

## 5 **Rinsing phase:**

**Descaling**  
Rinsing under way.  
Wait a few more  
minutes.

In this phase, after having drained the reactant, **3** rinsing cycles are carried out in this manner:

- a) Water loading with discharge open for **60** seconds.
- b) Water loading for **20** seconds past the level.
- c) Water discharge for 10 seconds below the level.

During the rinsing phase a lack of water may be diagnosed; in this case the procedure is suspended and the following message appears:

**Descaling**  
No water! To start  
rinsing again press  
button

By pressing the encoder button the procedure restarts from phase c) and if the lack of water persists the water missing signal returns.

## 6 **End of procedure**

**Descaling**  
Descaling  
completed.

To exit and return to normal operation, press on the pop-up area of the touch screen, or press Esc or the encoder key.

### **Decalcification request**

To prevent the boiler being ruined because the user forgets to descale, there is a warning signal every time the oven is switched on if over **P404** hours of operation of the boiler have gone by since the last descaling (default 250 hours). The following pop-up appears that can be removed via key confirmation or touch screen:

We advise carrying  
out a boiler  
descaling cycle

 OK

## 6.2

**CLEANING OVEN CAVITY**

At the end of a working day, clean the equipment, both for hygienic reasons and to avoid malfunctionings.

The oven must never be cleaned using direct or high pressure water jets. In the same manner, to clean the appliance do not use pan-scrubbers, steel brushes or scrapers; it is eventually possible to use stainless steel wool, rubbing it in the direction of the sheets satin finish.

**Manual cleaning**

Wait for the cooking compartment to cool down.

Remove the side tray racks.

Remove the manually removable residues and place the removable parts inside dishwashers.

To clean the cooking compartment use soapy warm water. Subsequently, all interested surfaces must be thoroughly rinsed, being careful to ensure no detergent residues remain.

To clean the oven external parts, use a damp cloth and a non-aggressive detergent.

**Automatic Washing System**

In ovens equipped with Automatic washing function, the above described phases happen automatically.

With this type of ovens, to perform washing, connect the pump float to a detergent tank and select Washing (See the instructions manual). The 4 automatic washing levels for the touch screen version (Hard, Intense, Normal, Soft) are selected according to the cleaning necessary to remove the cooking residue in the compartment (Hard=deep clean, for very resistant dirt, Soft=light wash).

Washing can be interrupted at any moment, by pressing the button Start/Stop until loading the detergent. After loading, one must wait for the washing cycle to finish.

To perform best results in automatic whashing system is recommended to use:

**BKI OVEN CLEANER AND RINSE AGENT**

**TECHNICIAN CAN INTERRUPT THE WASHING CYCLE BY PRESSING THE KNOB FOR 10 SECONDS AND INSERT PASSWORD 222**

## 6.3

## CLEANING PANEL AIR FILTER

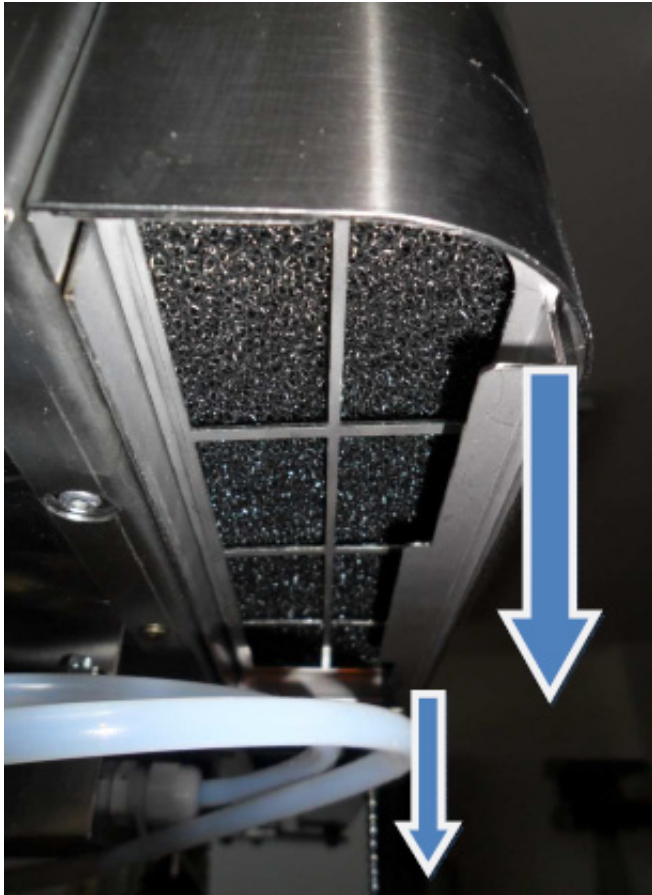

The filter is located under the panel.  
Pull it downward to remove it, so the two clips unhook.



Separate the filter from the filter holder and wash it with water and soap. Then reassemble the filter in the holder and install it under the oven panel.

**Hi temp**

*see page 33*

## 6.4

## ADJUSTMENT OF THE HINGES AND THE CLOSING PIVOT OF THE DOOR

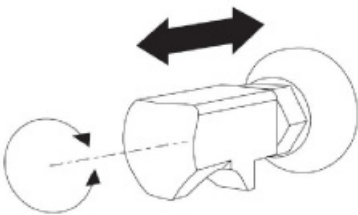
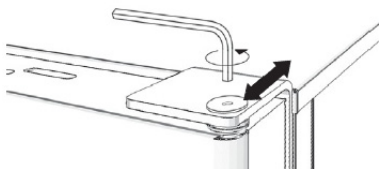

The door hinges must be adjusted to assure maximum seal of the oven door during its functioning. It is possible to adjust both the upper and lower hinges.

If required, to adjust the door seal, loosen the bolt and move the door in wanted position. Once adjusted, fasten the bolt again.

The door's closing pin can be adjusted in depth to eliminate any steam emissions during cooking.

It is possible to adjust pressure applied by the door on the gasket by tightening the pin to increase or loosening the pin to decrease it.

Once adjusted, fasten the bolt again ensuring to have positioned the lock closing anchoring downwards.

The standard distance between door and front part of the oven is more or less 13-14 mm with a new gasket.

6.5

CHANGING DOOR LIGHTS AND GLASS CLEANING



The door glass can be cleaned externally and internally.

For this purpose, turn the stop holding the internal glass in position clockwise and, once the glass is opened, clean it with suitable detergent. Never use abrasive materials. The glass must be correctly closed and locked in position by turning the stop anti-clockwise.

To replace the bulbs remove the protective glass and replace the defective bulb with same type (Halogen 12 Volt).

6.6

WASHING SPRINKLER CLEANING



**7.0****SPECIAL MAINTENANCE****7.1****BOILER OPENING AND CHECK****STEP 1:**

turn the boiler bottom part to left and the upper part to the right.

**STEP 2:**

Pull down the bottom part of the boiler

**STEP 3:**

Verify the probe status and clean the boiler with a special product if needed.

## 7.2

## FANS REPLACEMENT

## TOOLS SET





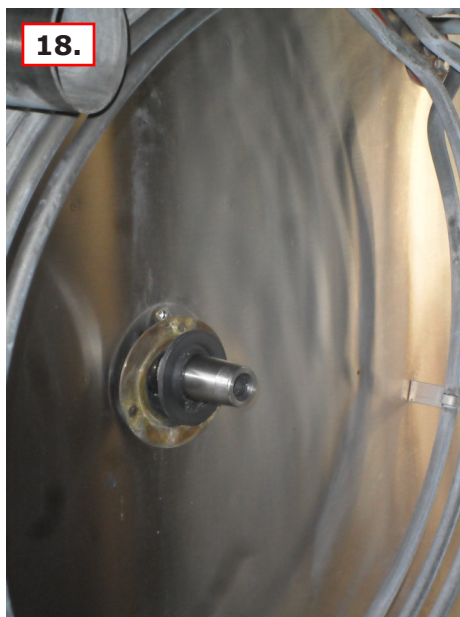

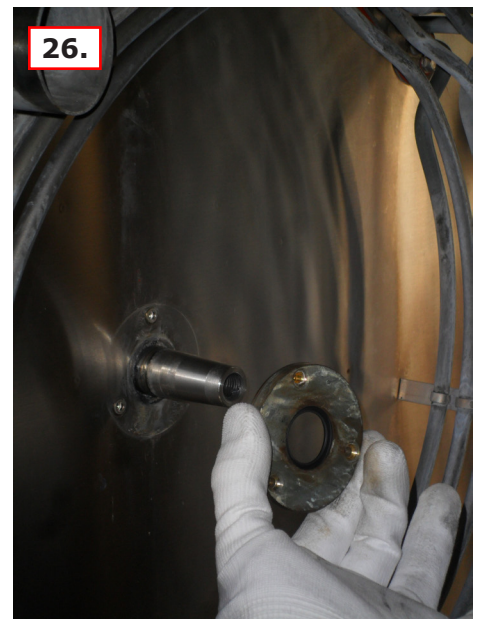
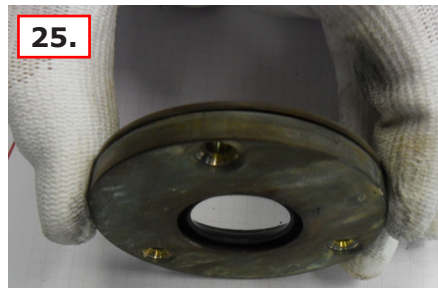
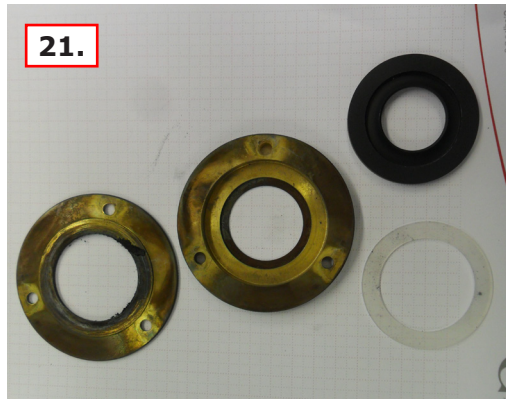
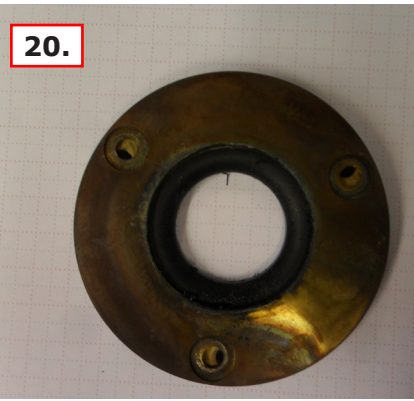

7.3

DOOR GASKET REPLACEMENT

**NECESSARY: SILICONE, CUTTER AND 1 NEW GASKET**



**1. REMOVE THE OLD GASKET**



**2. CAREFULLY CLEAN THE SEAT OF THE GASKET**



**3. PREPARE THE SEAT WITH SILICONE ALL ALONG THE PERIMETER, IN ALL RIVETS AND IN THE CORNERS**



**4. FIX THE NEW GASKET. FIRST ON TOP**

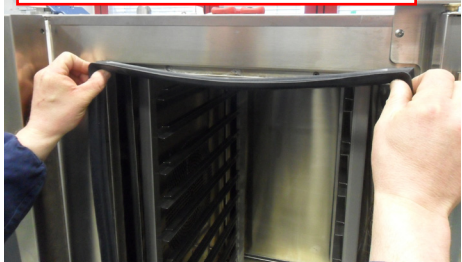

**5. THEN ON THE BOTTOM**



**6. PUSH THE GASKET IN SEAT ALL ALONG THE PERIMETER**



**7. PULL THE GASKET IN ITS SEAT OF ABOUT 2 mm. LOWER SIDE ONLY**



**8. CAREFULLY COVER THE LOWER FESSURE WITH SILICONE**

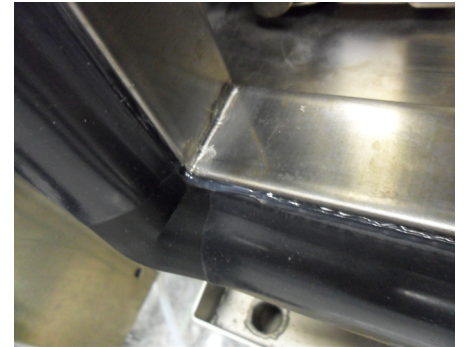
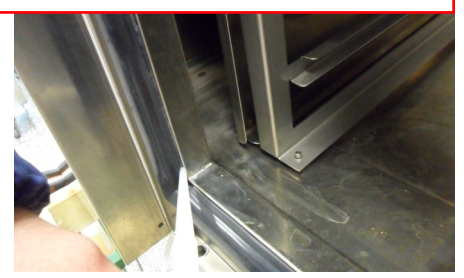
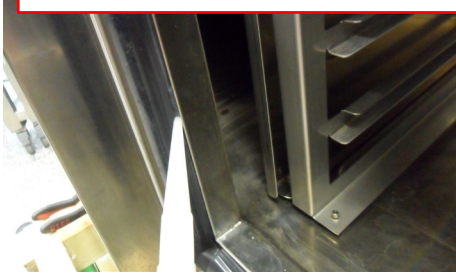

**9. CAREFULLY PUSH THE GASKET BACK IN SEAT**



**10. CLEAN THE EXCEEDING SILICONE**



**11. WAIT 8 HOURS WITH DOOR OPENED**

## 7.4

## COMPLETE DOOR HANDLE REPLACEMENT

### TOOLS NEEDED



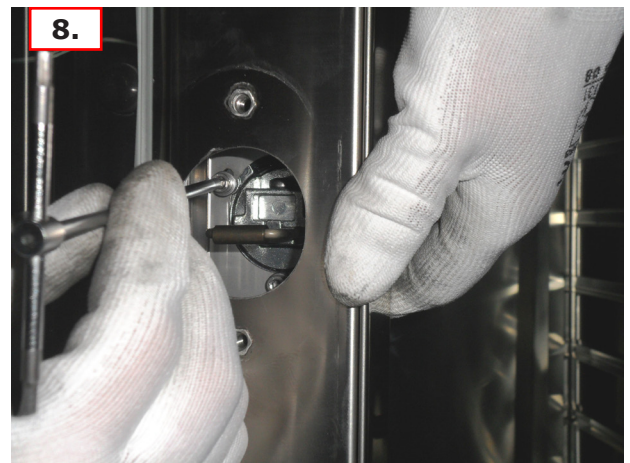
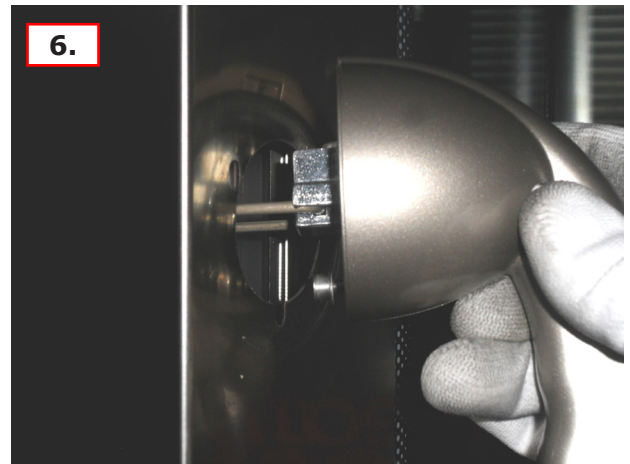
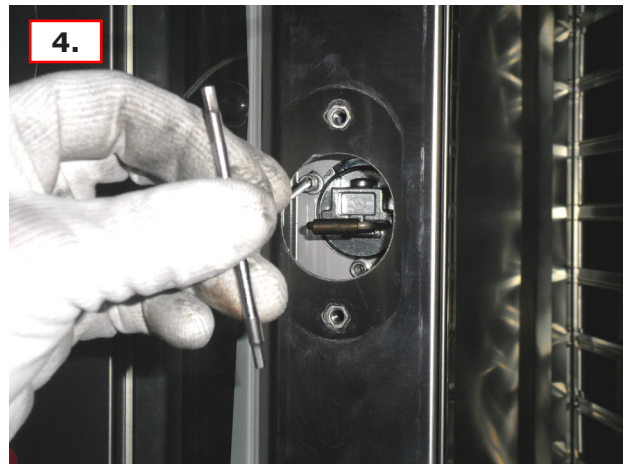
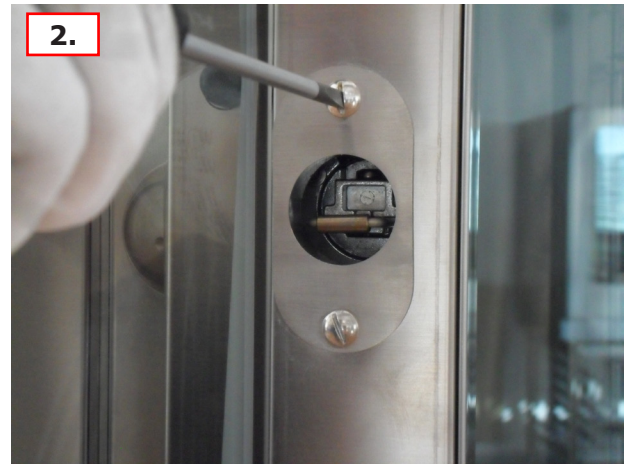

**8.0****ELECTRICAL DRAWINGS****LEGEND**

<b>C,C1,,,</b>	Capacitor
<b>EU,EU1,EU2</b>	Electrovalve for humidifier
<b>EA</b>	Steam kill solenoid valve
<b>EL</b>	Washing electrovalve
<b>ES</b>	Boiler discharge electrovalve
<b>ESH</b>	Hand shower electrovalve
<b>EV</b>	Boiler load electrovalve
<b>EVG</b>	Gas solenoid valve
<b>FM1,FM2</b>	Motor thermic protection (incor.)
<b>FU1,FU2...</b>	Fuse
<b>FLC</b>	Filter E.M.C.
<b>FR1,FR2...</b>	Cooling fan
<b>FS1</b>	Chamber safety thermostat
<b>FS2</b>	Bolier safety thermostat
<b>IGN,IGN1,IGN2</b>	Burner control
<b>INV,INV1,INV2</b>	Motor inverter
<b>K0</b>	Inverter line relay
<b>KØA,KØB</b>	Auxiliary power line contactor
<b>Keyboard</b>	Keyboard electronic card
<b>KR1/3,....</b>	Chamber resistance contactor
<b>L1, L2</b>	Chamber lighting lamp
<b>M1, M2..</b>	Motor
<b>MB1,MB2..</b>	Gas Blower
<b>MS</b>	Discharge valve motorized
<b>MV</b>	Humidity discharge valve
<b>P1,P2..</b>	Burner air pressure switch
<b>PA</b>	Water pressure switch
<b>PB</b>	Rinsing agent pump
<b>PFC</b>	PFC
<b>PD</b>	Detergent pump
<b>PL</b>	Washing pump
<b>PWM</b>	Gas blower speed control board
<b>R1,R2....</b>	Resistance
<b>S0</b>	Main switch
<b>SC</b>	Chamber probe
<b>SCHF</b>	Oven control electronic card
<b>SP</b>	Door microswitch
<b>SS</b>	Core Probe
<b>SU1, SU2</b>	Umidity probe
<b>TR1</b>	Trasformer 230V/12V, 12VA - 5VA
<b>TR2,TR3</b>	Trasformer 230V/24V AC
<b>TRAL</b>	Chamber light trasformer 230V/12V AC
<b>X./..</b>	Power plug
<b>Z1</b>	Boiler level control probe

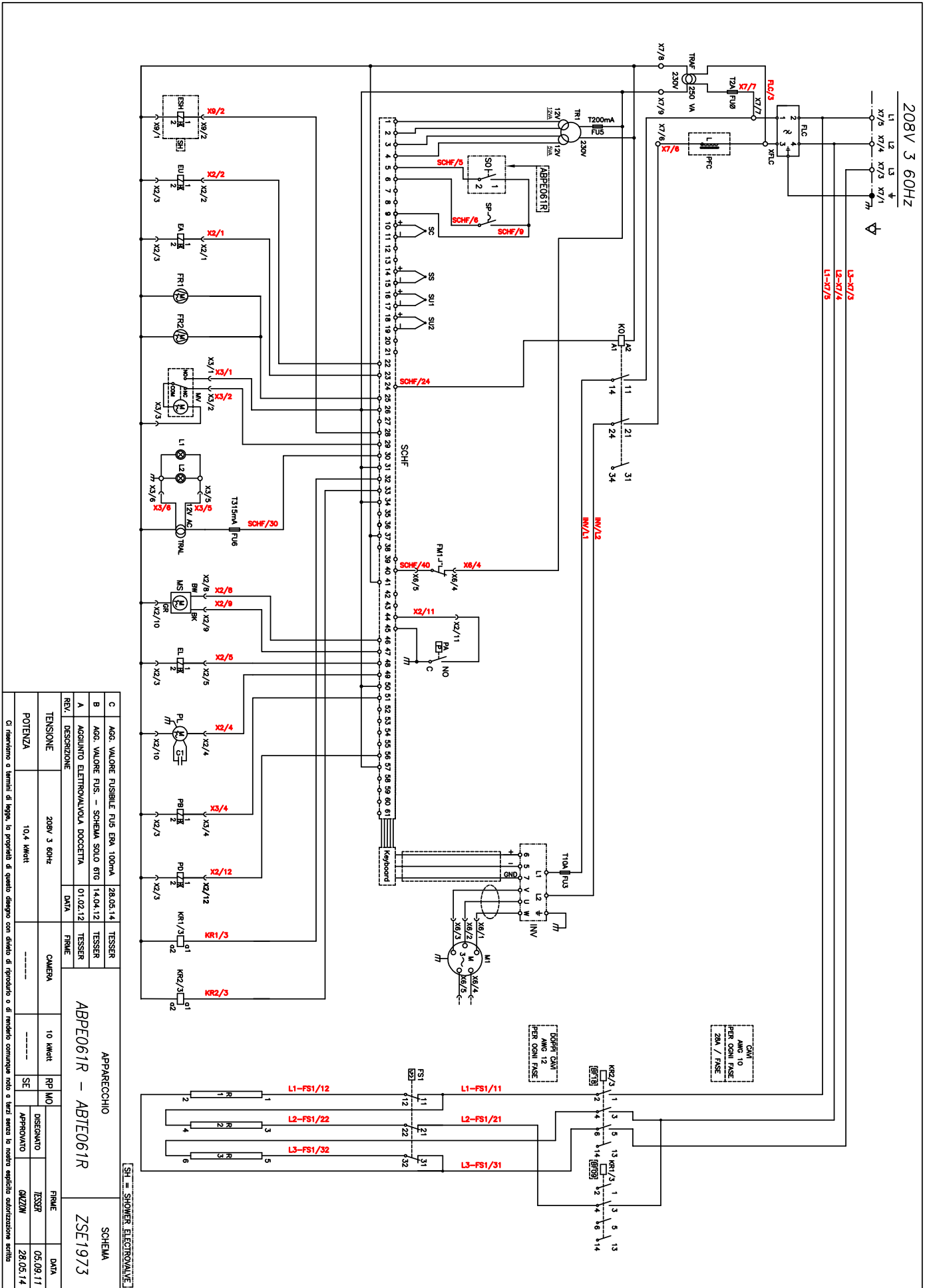

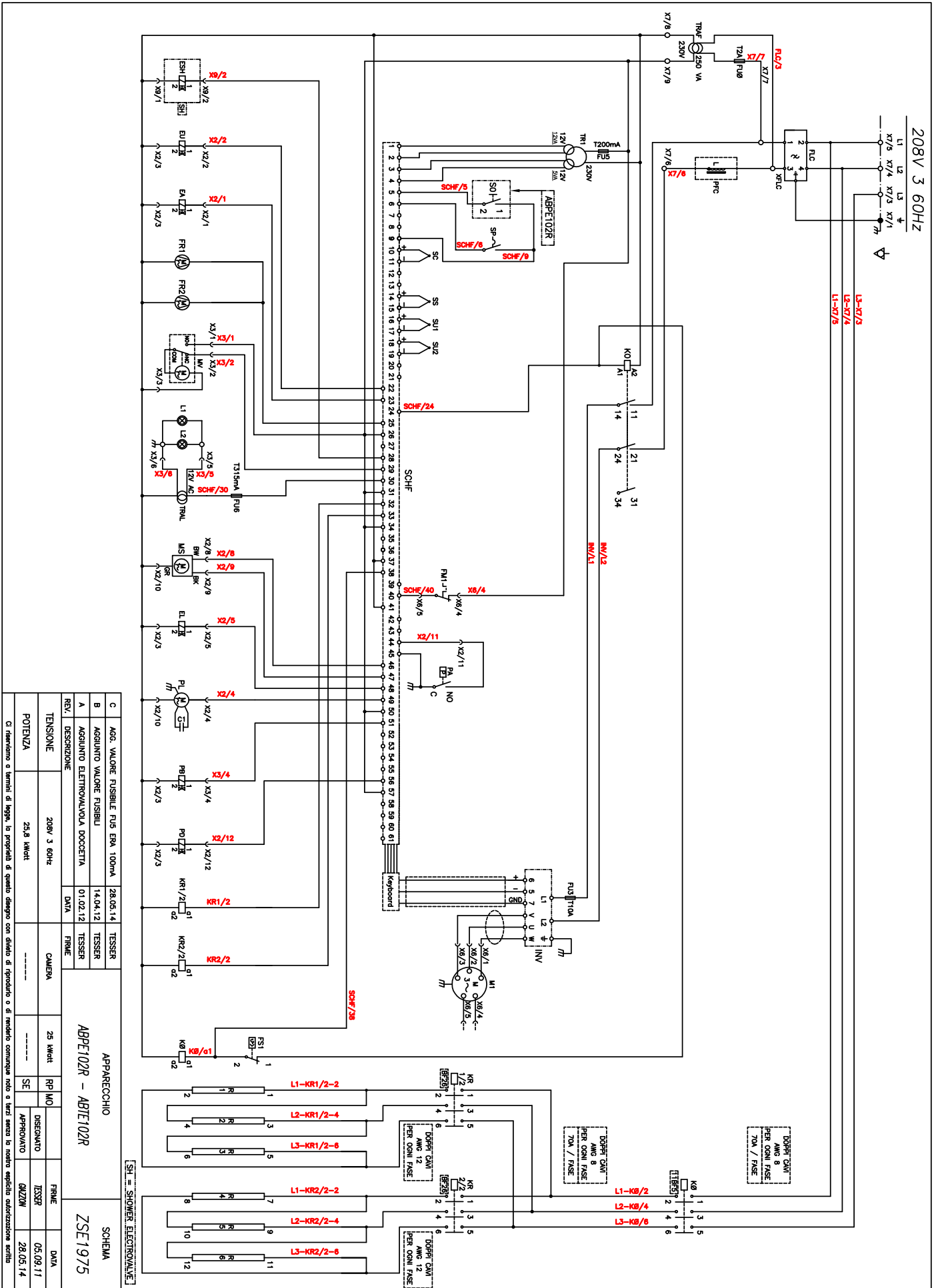

AGG. VALORE FUSIBILE FUS ERA 100mA		28.05.14	TESSER
AGGIUNTO VALORE FUSIBILI		14.04.12	TESSER
AGGIUNTO ELETTROVALVOLTA DOCCETTA		01.02.12	TESSER
REV.	DESCRIZIONE	DATA	FIRME
TENSIONE		208V 3 60Hz	CAMERA
POTENZA		25.8 kWatt	RP/MO
DISEGNATO		TESSER	05.09.11
APPROVATO		DAZZINI	28.05.14
FIRME		DATA	

APPARECCHIO: ABPE102R - ABTE102R

SCHEMA: ZSE1975

SH = SHOWER ELETTRICALE

CI riserviamo a termini di legge, la proprietà di questo disegno con diritto di riproduzione o di rinvio con qualsiasi modo e senza senza la nostra esplicita autorizzazione scritta

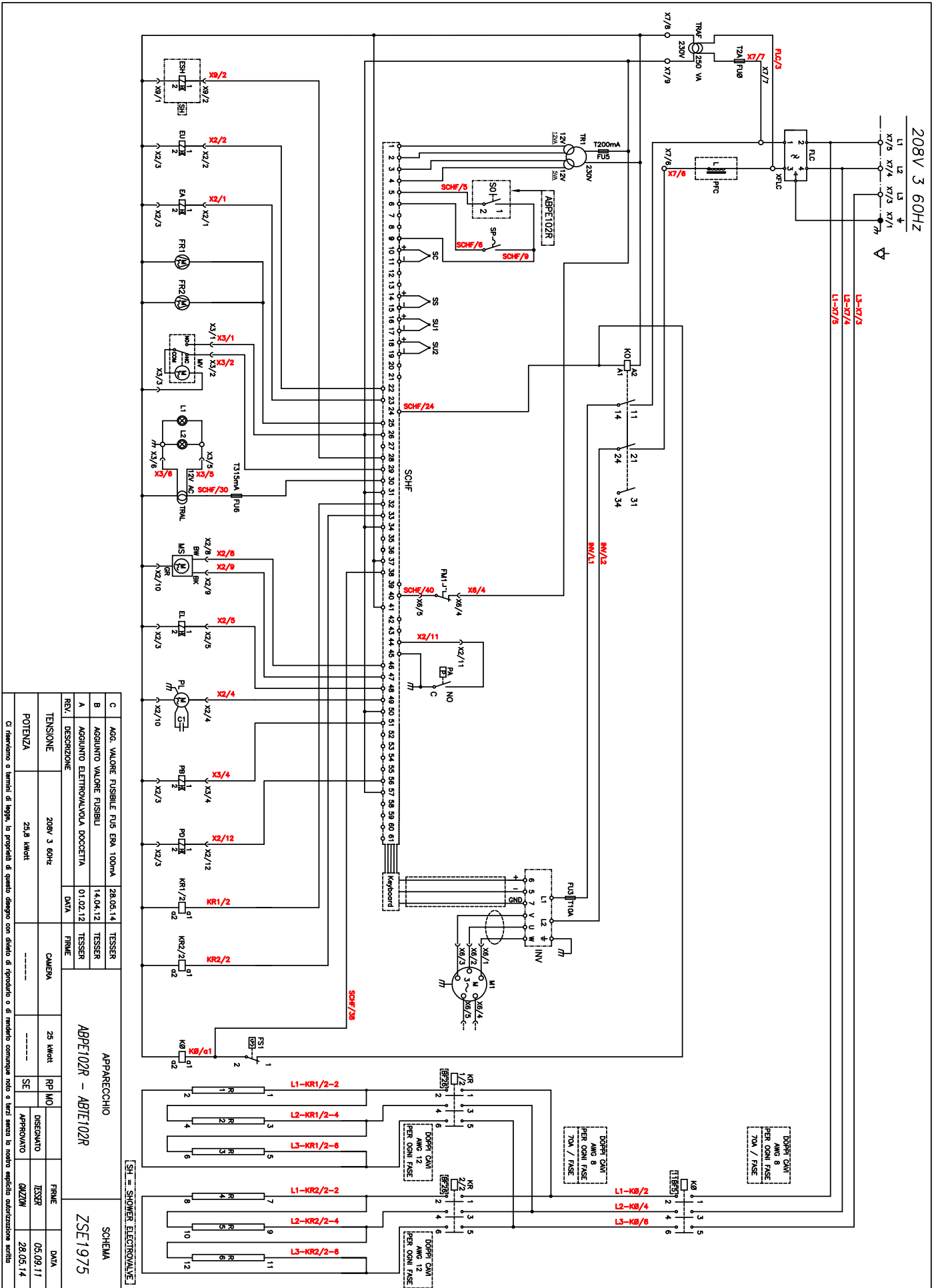

AGG. VALORE FUSIBILE FUS ERA 100mA		28.05.14	TESSER
AGGIUNTO VALORE FUSIBILI		14.04.12	TESSER
AGGIUNTO ELETTROVALVOLTA DOCCETTA		01.02.12	TESSER
REV.	DESCRIZIONE	DATA	FIRME
TENSIONE		208V 3 60Hz	CAMERA
POTENZA		25,8 kWatt	RP/MO
DISEGNATO		TESSER	05.09.11
APPROVATO		DAZZINI	28.05.14
FIRME		DATA	

APPARECCHIO: ABPE102R - ABTE102R

SCHEMA: ZSE1975

SH = SHOWER ELETTRICAMENTE

CI riserviamo a termini di legge, la proprietà di questo disegno con diritto di riproduzione o di ristampa comunque noto e senza senza la nostra esplicita autorizzazione scritta





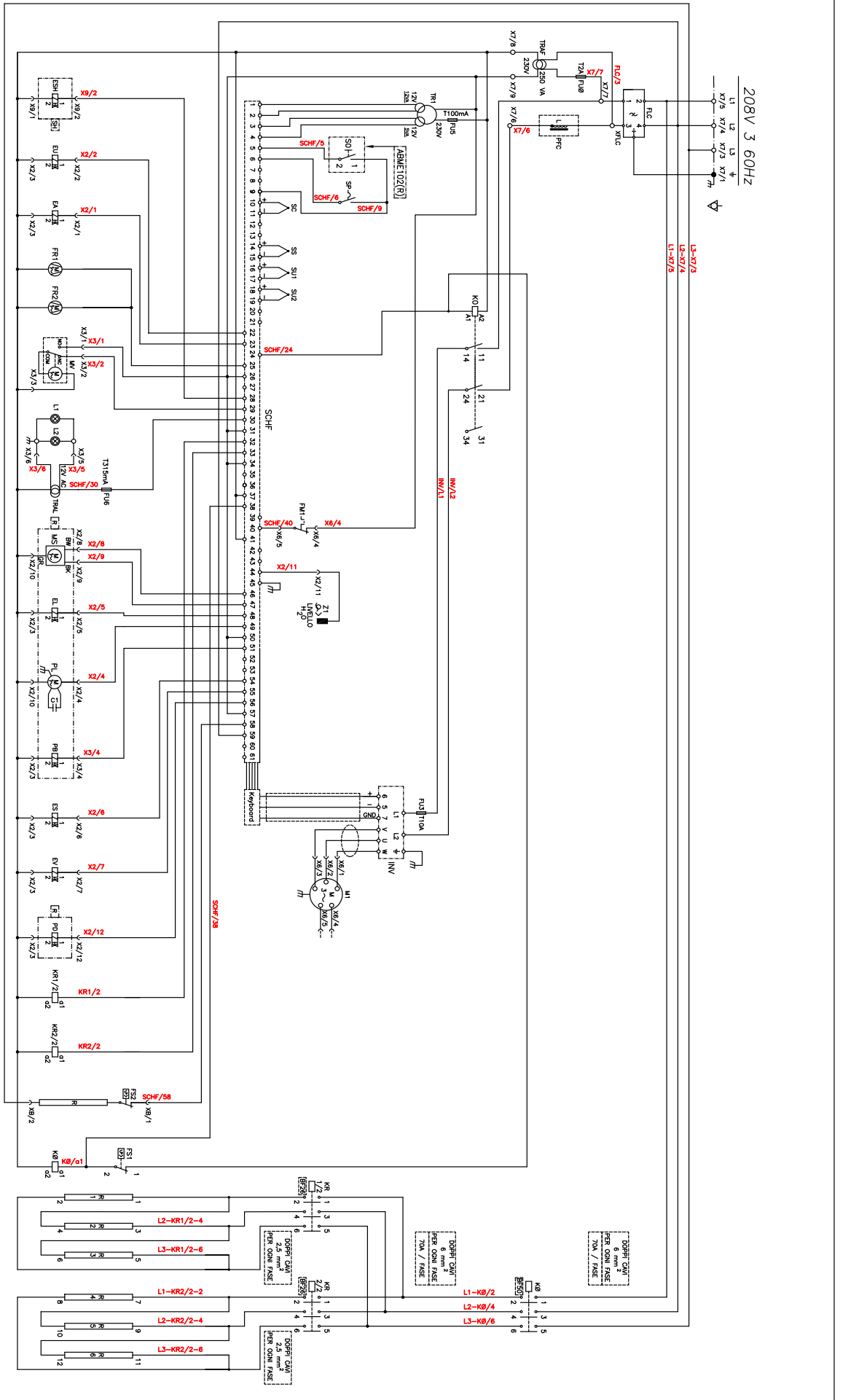

[S] = SHOWER ELECTROVALVE

[R] = WASHING+RINSE SYSTEM (OPTIONAL)

APPARECCHIO		SCHEMA	
ABHE102(R) - ABME102(R)		ZSE1985	
REV.	DESCRIZIONE	DATA	TESSER
A	AGGIUNTO VALORE FUSIBILI + SHOWER ELECT.	14.04.12	
TENSIONE		208V 3 60Hz	
POTENZA		27,8 kWatt	
REV.	DESCRIZIONE	DATA	TESSER
	CAMERA	25 kWatt	
	BOLLER	2 kW	
DISIGNATO	TESSER	05.09.11	
APPROVATO	QUZZINI	14.04.12	

Ci riserviamo a termini di legge, la proprietà di questo disegno con diritto di riproduzione o di renderlo comunque noto a terzi senza il nostro esplicito autorizzazione scritto

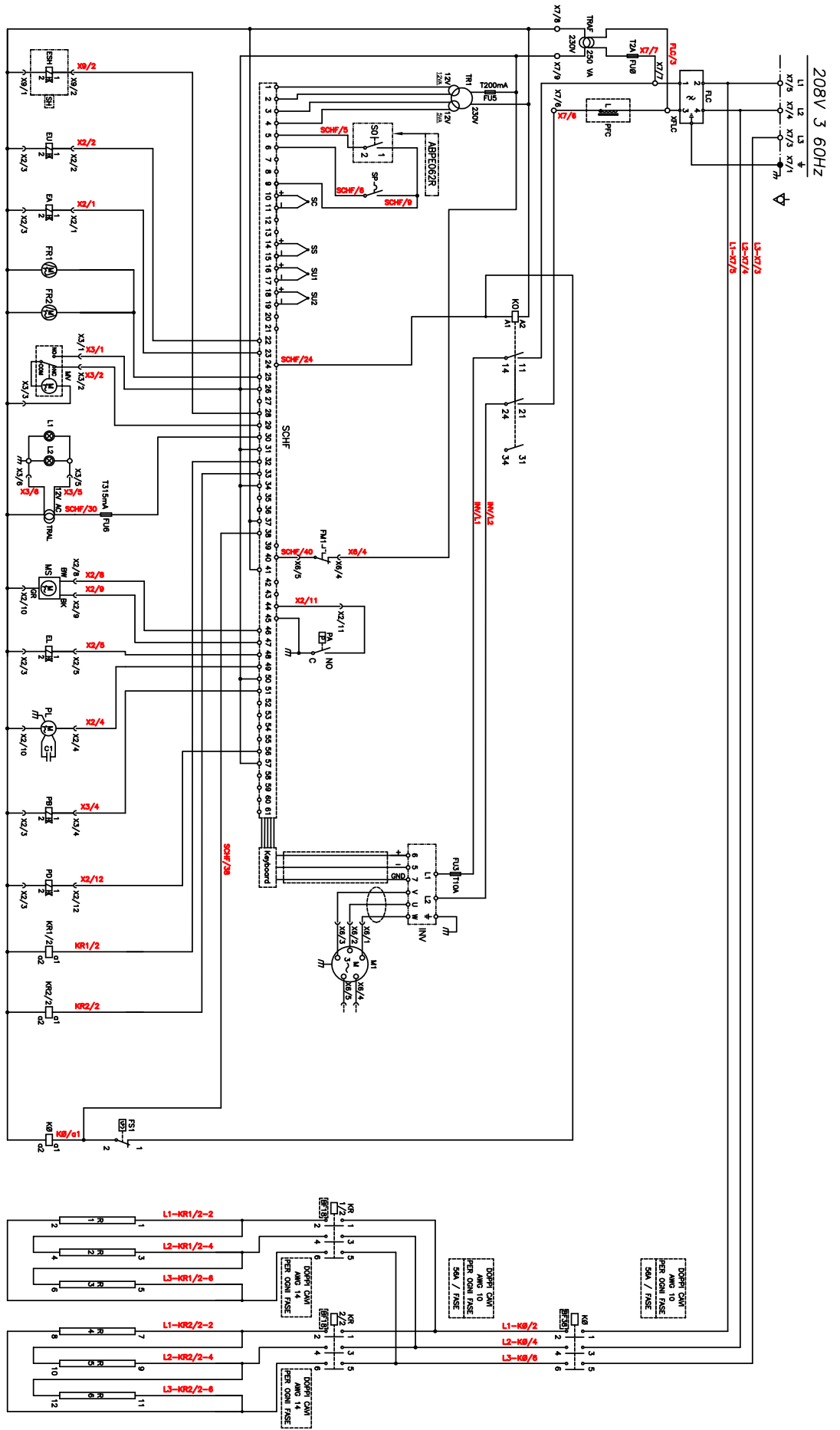

SCH = SHOWER ELECTROVALVE

APPARECCHIO		SCHEMA	
ABPE062R - ABTE062R		ZSE1995	
REV. DESCRIZIONE	DATA	FINIRE	DATA
A	AGG. VALORE FUSIBILE FUS ERA 100mA	28.05.14	TESSER
TENSIONE		208V 3 60Hz	
POTENZA		20.4 kWht	
DESIGNATO	TESSER	12.02.13	
APPROVATO	QUZZI	28.05.14	

CI riserviamo a termini di legge, la proprietà di questo disegno con diritto di riproduzione o di materiale comunque noto o fuori senza la nostra esplicita autorizzazione scritta

9.0

SPARE PARTS EXPLODED VIEW

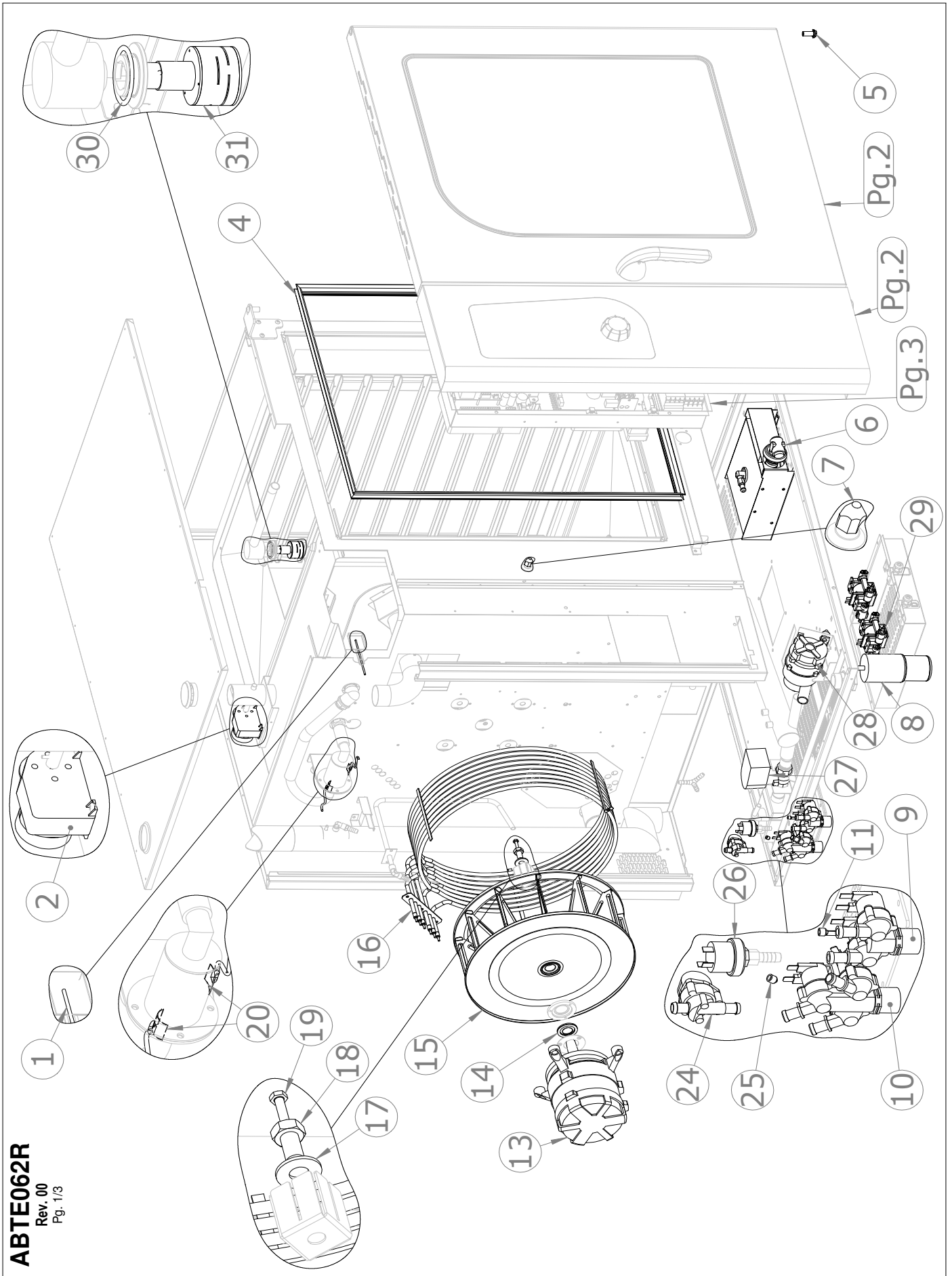

**ABTE062R**  
Rev. 00  
Pg. 1/3

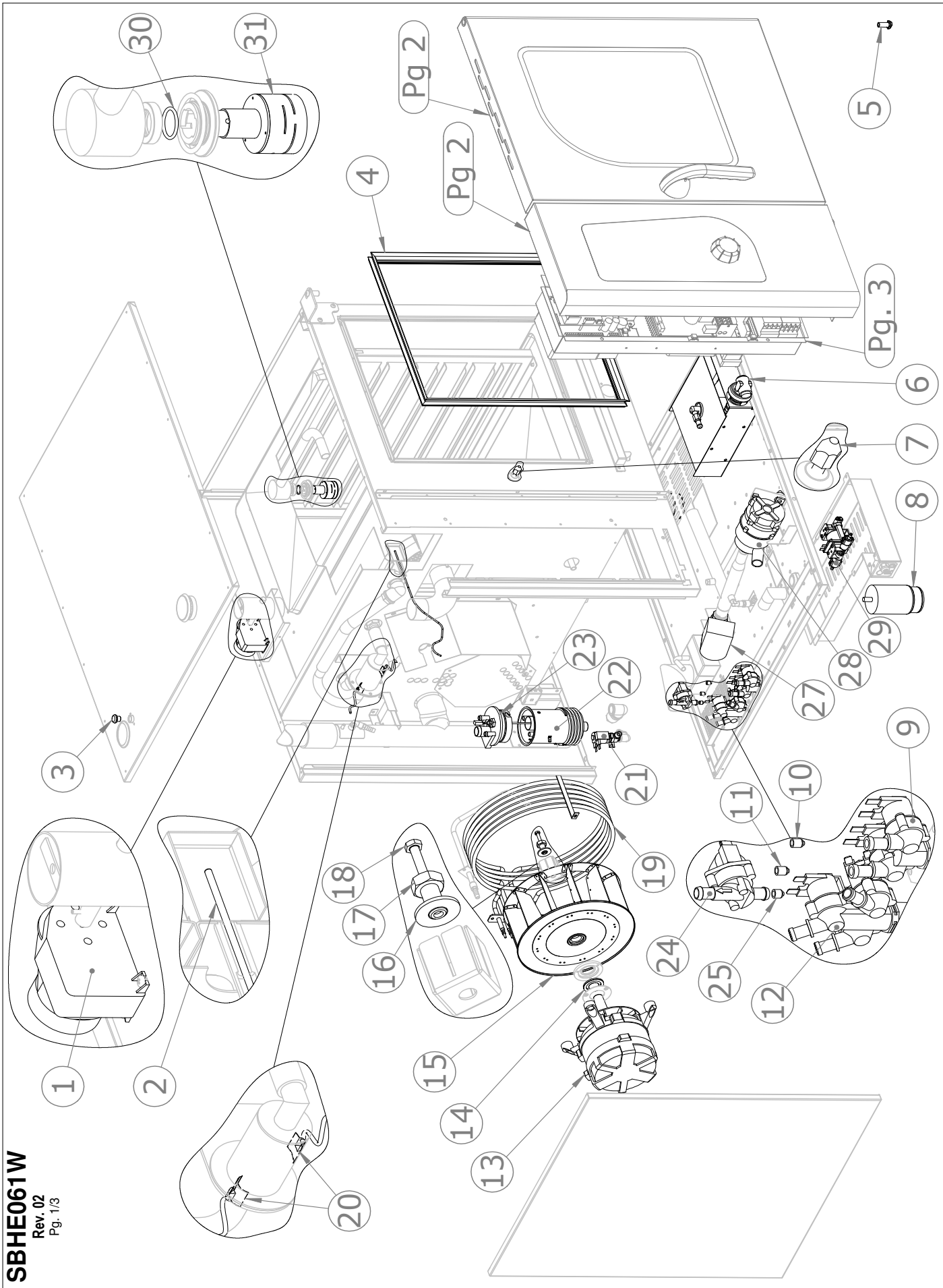

**SBHE061W**  
Rev. 02  
Pg. 1/3

# ABTE062R

Rev. 00  
Pg. 3/3

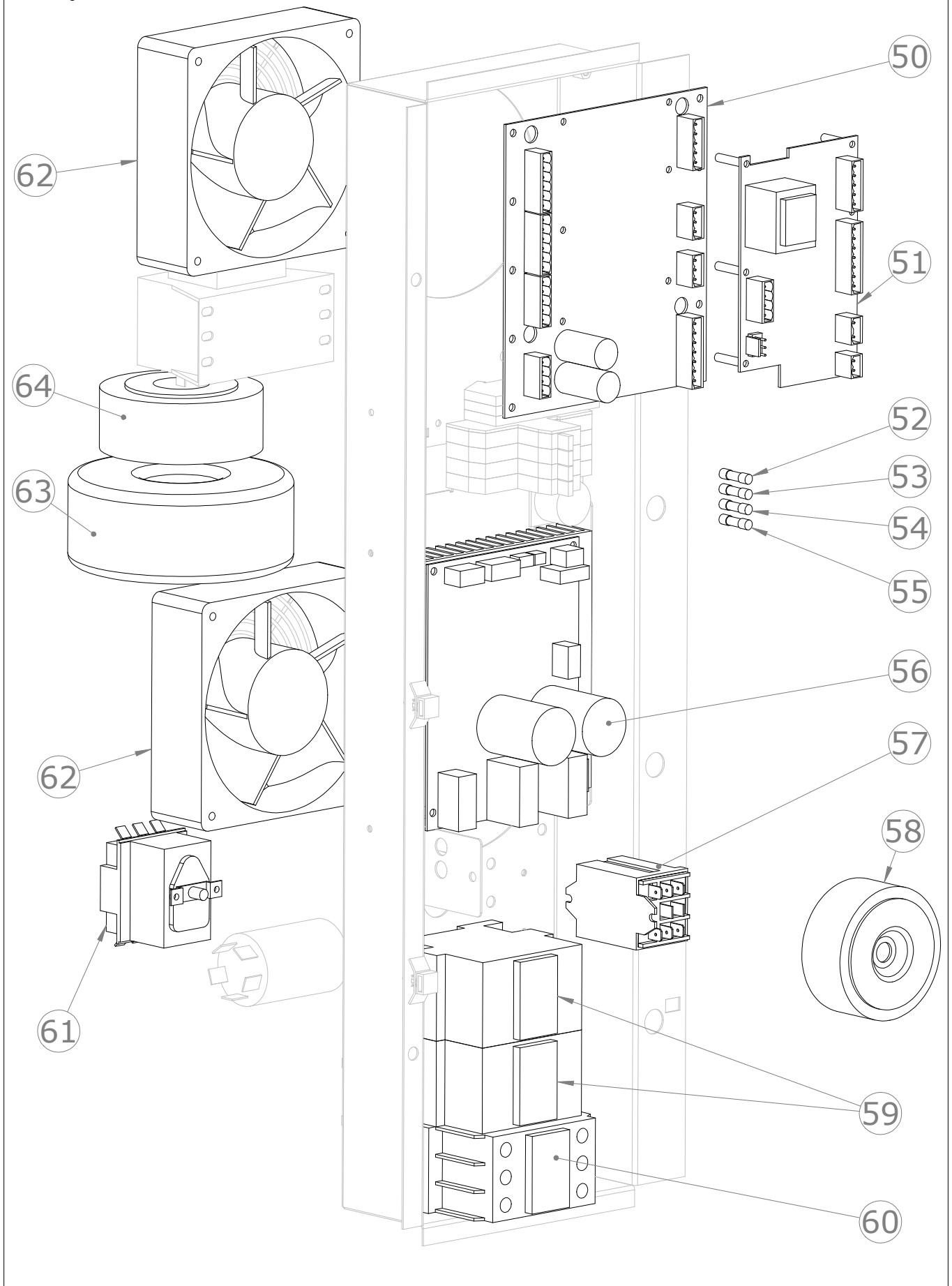

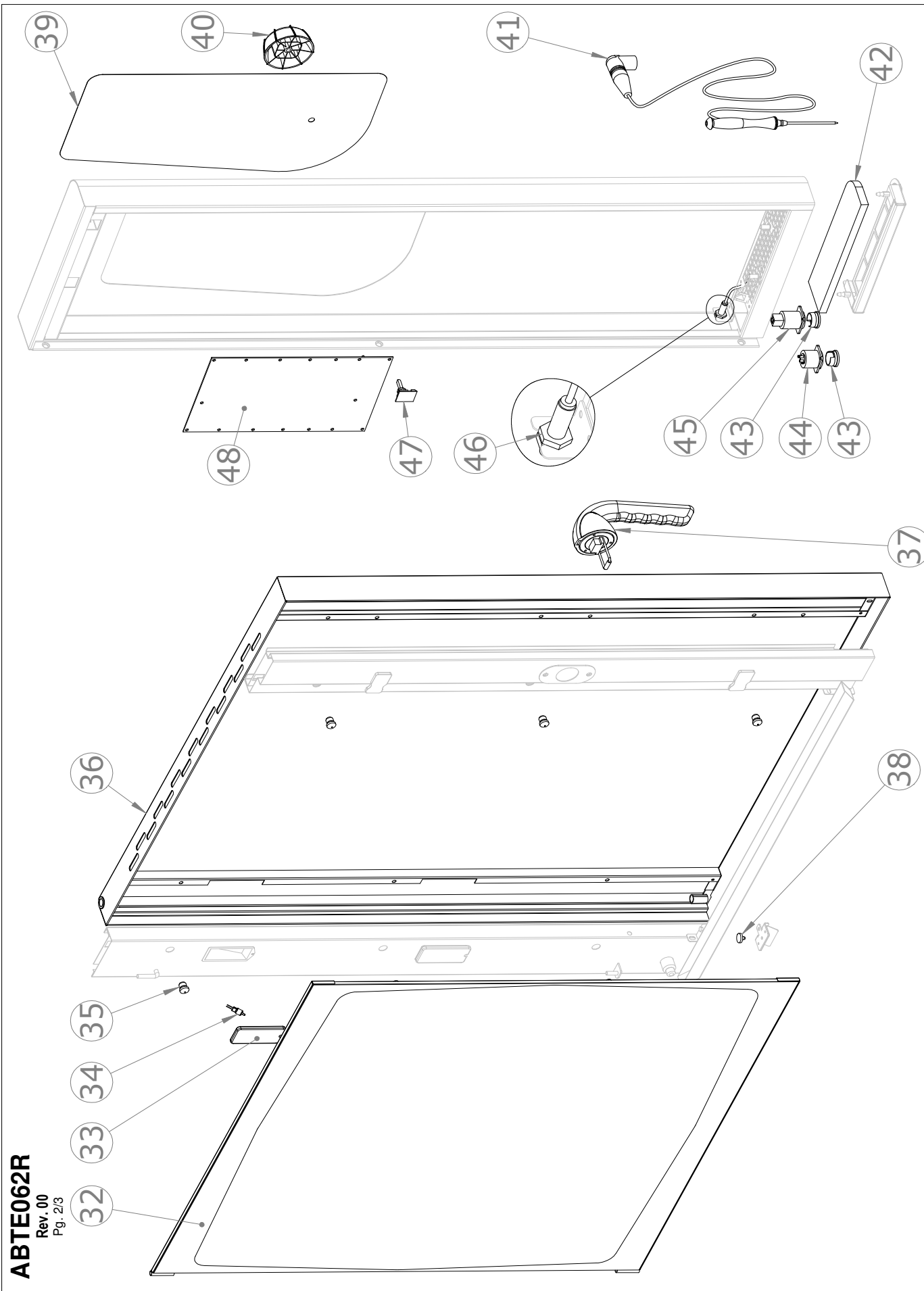

**ABTE062R**  
Rev. 00  
Pg. 2/3

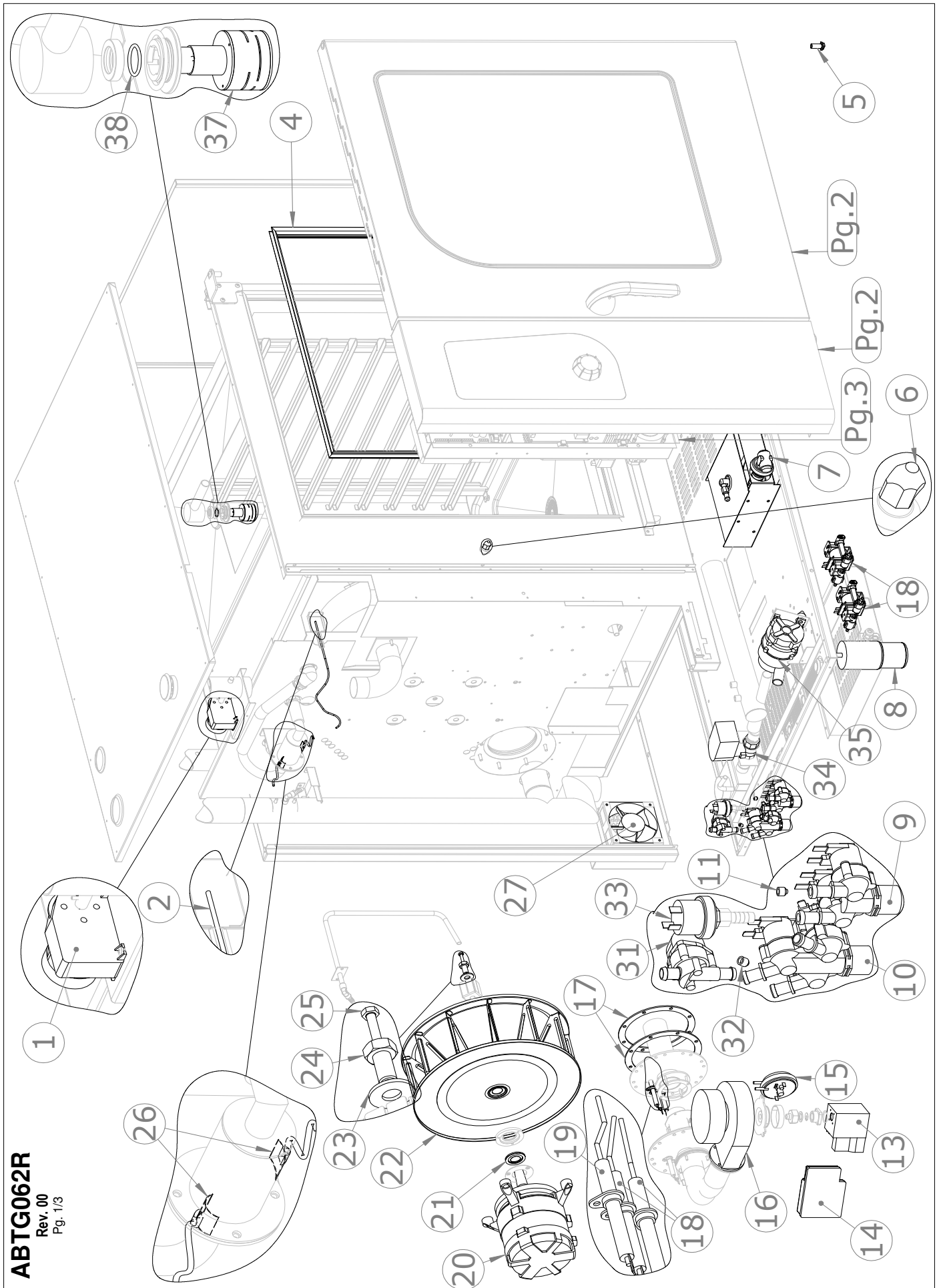

**ABTG062R**  
Rev. 00  
Pg. 1/3

# ABTG062R

Rev. 00

Pg. 3/3

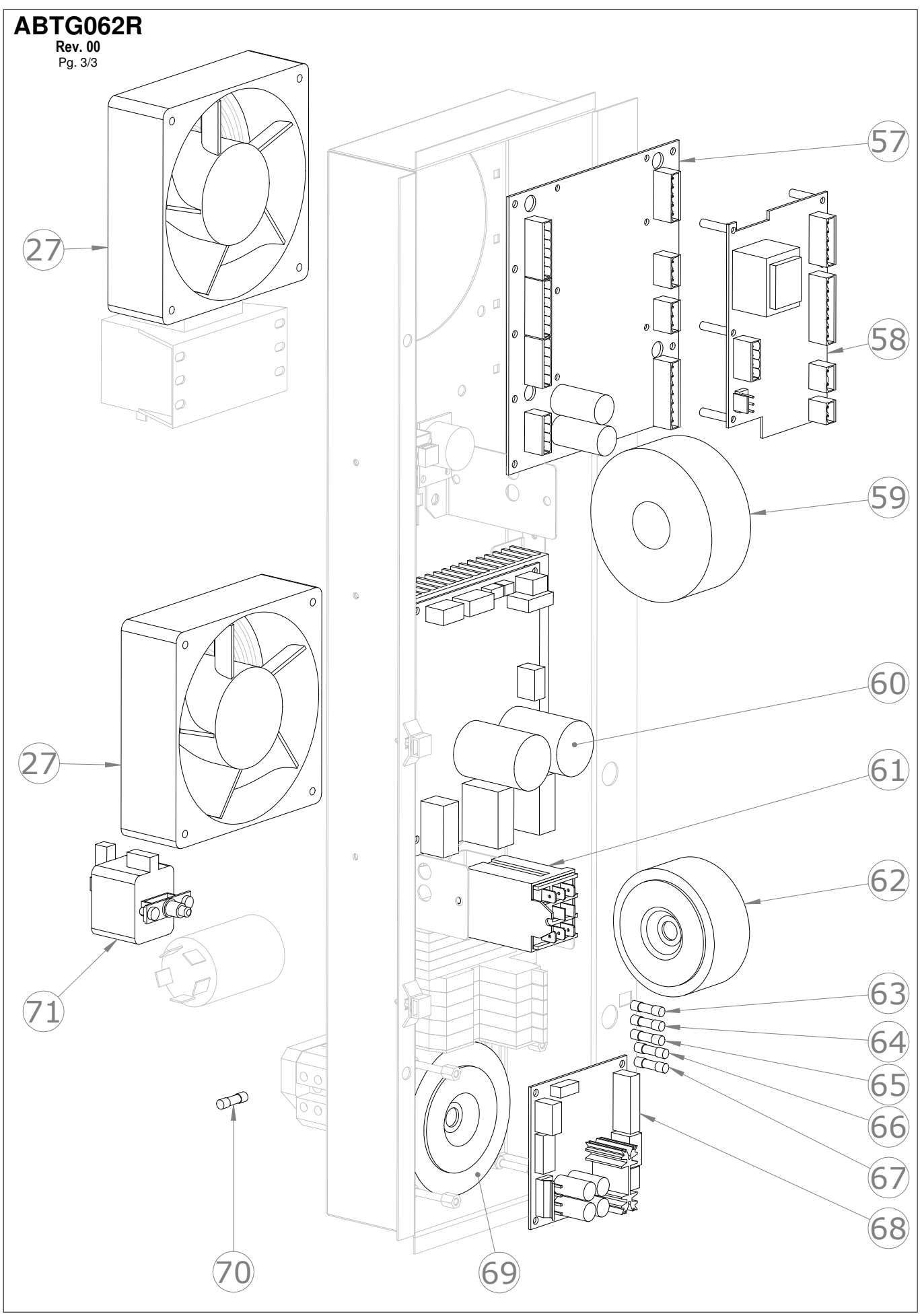

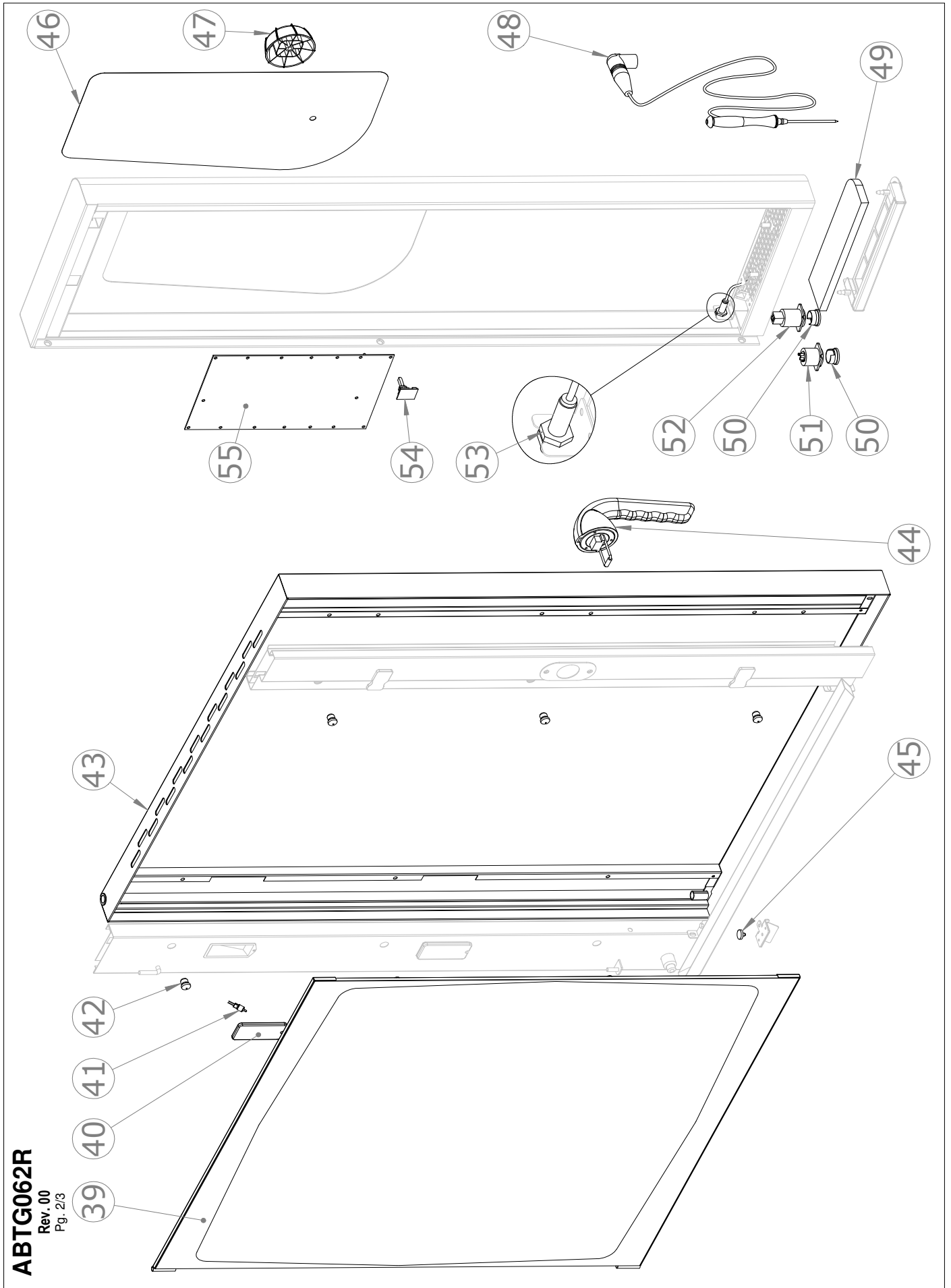

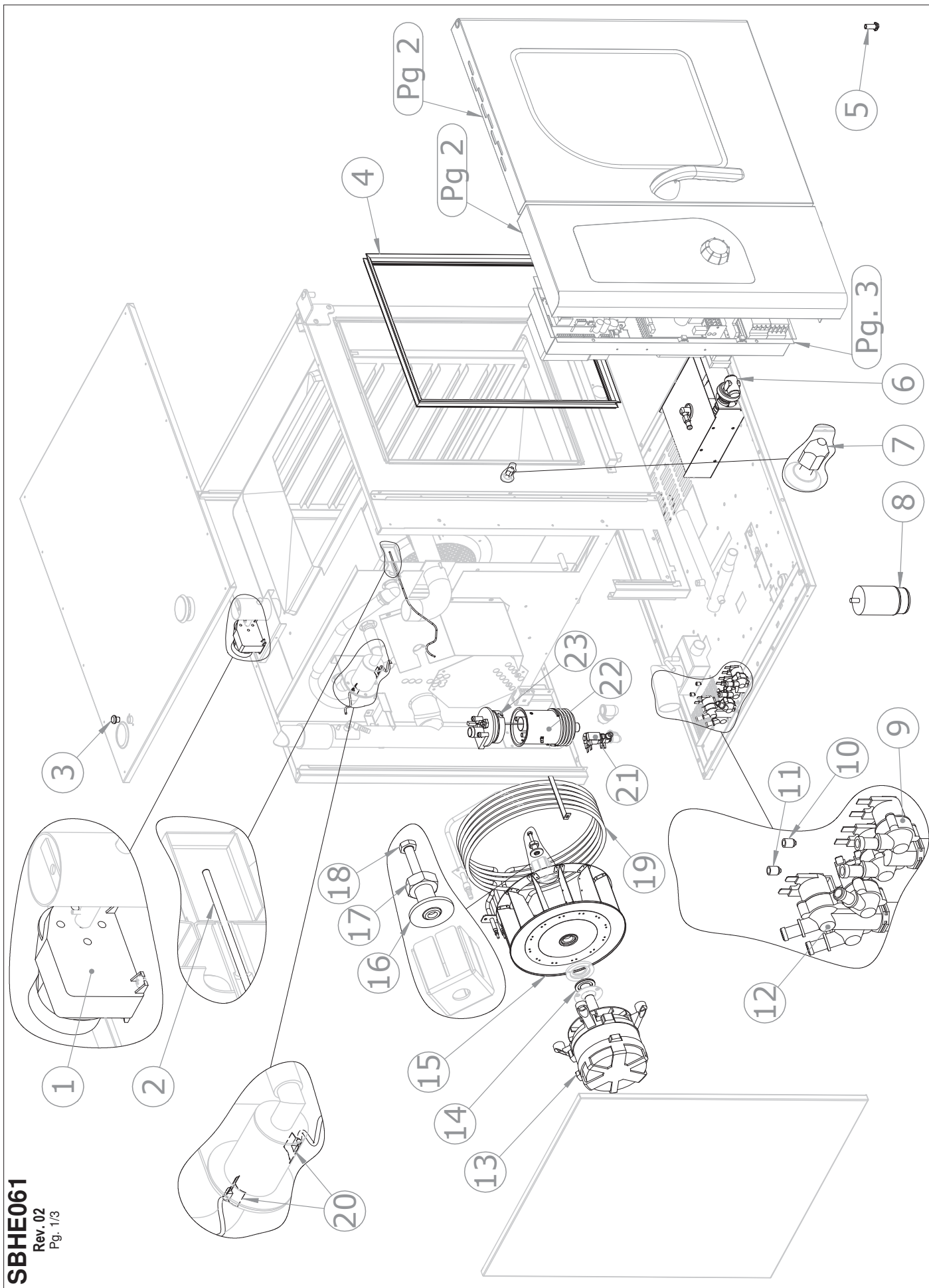

**SBHE061**  
Rev. 02  
Pg. 1/3







by

**GIORIK**  
INNOVATIVE COOKING EQUIPMENT SINCE 1963