

Holding Cabinet

Models HHC, HHC-T

Service Manual

Serial Numbers 123317 and Higher



Fresh ideas in foodservice equipment

Warranty Information

LIMITED ONE YEAR WARRANTY

BKI (The "Company") warrants to the original purchaser/user, that at time of shipment from the Company factory, this equipment will be free from defect in materials and workmanship. Written notice of a claim under this Warranty must be given within **ONE YEAR AND THREE MONTHS** from date of shipment from the factory. Defective conditions caused by abnormal use or misuse, lack of maintenance, damage by third parties, alterations by unauthorized personnel, acts of God, failure to follow installation instructions or any other events beyond the control of the company will **NOT** be covered under Warranty. The obligation of the Company under this Warranty shall be limited to repairing or replacing (at the option of the company) any part which is defective in reasonable opinion of the Company. The user will have the responsibility and expense of removing and returning the defective part to the Company as well as the cost of reinstalling the replacement or repaired part.

IN NO EVENT SHALL THE COMPANY BE LIABLE FOR LOSS OF USE, LOSS OF REVENUE OR LOSS OF PRODUCT OR PROFIT OR FOR INDIRECT OR CONSEQUENTIAL DAMAGES INCLUDING BUT NOT LIMITED TO, FOOD SPOILAGE OR PRODUCT LOSS. WARRANTY DOES NOT COVER GLASS BREAKAGE. THE ABOVE WARRANTY IS EXCLUSIVE AND ALL OTHER WARRANTIES, EXPRESS OR IMPLIED, ARE EXCLUDED INCLUDING THE IMPLIED WARRANTIES OF MERCHANTABILITY AND FITNESS FOR A PARTICULAR PURPOSE. THIS WARRANTY SHALL APPLY ONLY WITHIN THE CONTINENTAL UNITED STATES, ITS TERRITORIES, AND POSSESSIONS AND IN CANADA.

LIMITED NINETY DAY LABOR WARRANTY

All labor necessary to repair or replace factory defective parts will be performed, without charge, to the end user, by service personnel of a **BKI** Authorized Distributor during the first ninety days after the date of installation of the new equipment.

Replacement parts: Any appliance replacement part, except lamps and fuses, which proves to be defective in material or workmanship within 90 days from date of original installation will be repaired or replaced without charge F.O.B. Factory, Simpsonville, S.C. or F.O.B. authorized distributor.

Table of Contents

Table of Contents	1
Introduction.....	2
Safety Precautions	2
Safety Signs and Messages	2
Safe Work Practices	3
Safety Labels	4
Installation.....	5
Instructions For Shipping Damage	5
Floor Placement	5
Countertop Placement.....	5
Electrical Information.....	5
Replacement Parts	6
Assemblies & Components	6
Wiring Diagrams	10

Introduction

Congratulations! You have chosen a **Holding Cabinet** that will give you many years of fine service from the original manufacturer, **BKI**.

The **BKI** name and trademark on this unit assures you of the finest in design and engineering — that it has been built with care and dedication — using the best materials available. Attention to the operating instructions regarding proper installation, operation, and maintenance will result in long lasting dependability to insure the highest profitable return on your investment.

NOTICE

PLEASE READ THIS ENTIRE MANUAL BEFORE OPERATING THE UNIT. If you have any questions, please contact your **BKI** Distributor. If they are unable to answer your questions, contact the **BKI** Technical Service Department, toll free: 1-800-927-6887. Outside the U.S., call 1-864-963-3471.

Safety Precautions

Always follow recommended safety precautions listed in this manual. Below is the safety alert symbol. When you see this symbol on your equipment, be alert to the potential for personal injury or property damage.



Safety Signs and Messages

The following Safety signs and messages are placed in this manual to provide instructions and identify specific areas where potential hazards exist and special precautions should be taken. Know and understand the meaning of these instructions, signs, and messages. Damage to the equipment, death or serious injury to you or other persons may result if these messages are not followed.

⚠ DANGER

This message indicates an imminently hazardous situation that, if not avoided, will result in death or serious injury.

⚠ WARNING

This message indicates a potentially hazardous situation, which, if not avoided, could result in death or serious injury.

⚠ CAUTION

This message indicates a potentially hazardous situation, which, if not avoided, may result in minor or moderate injury. It may also be used to alert against unsafe practices.

NOTICE

This message is used when special information, instructions or identification are required relating to procedures, equipment, tools, capacities and other special data.

Safe Work Practices



Beware of High Voltage

This equipment uses high voltage. Serious injury can occur if you or any untrained or unauthorized person installs, services, or repairs this equipment. Always Use an Authorized Service agent to Service Your Equipment.

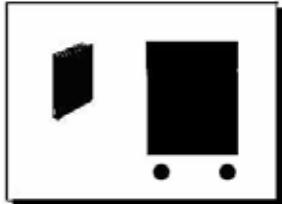

Keep this manual with the Equipment

This manual is an important part of your equipment. Always keep it near for easy access. If you need to replace this manual, contact:

BKI

Technical Services Department
 P.O. Box 80400
 Simpsonville, S.C. 29680-0400
 Or call toll free: 1-800-927-6887
 Outside the U.S., call 864-963-3471



Protect Children

Keep children away from this equipment. Children may not understand that this equipment is dangerous for them and others.

NEVER allow children to play near or operate your equipment.



Keep Safety Labels Clean and in Good Condition

Do not remove or cover any safety labels on your equipment. Keep all safety labels clean and in good condition. Replace any damaged or missing safety labels. Refer to the Safety Labels section for illustration and location of safety labels on this unit. If you need a new safety label, obtain the number of the specific label illustrated on page 4, then contact:

BKI

Technical Services Department
 P.O. Box 80400
 Simpsonville, S.C. 29680-0400
 Or call toll free: 1-800-927-6887
 Outside the U.S., call 864-963-3471

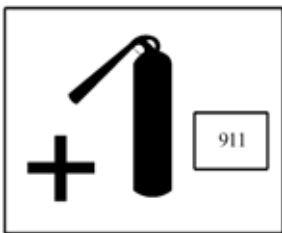

Be Prepared for Emergencies

Be prepared for fires, injuries, or other emergencies.

Keep a first aid kit and a fire extinguisher near the equipment. You must use a 40-pound Type BC fire extinguisher and keep it within 25 feet of your equipment.

Keep emergency numbers for doctors, ambulance services, hospitals, and the fire department near your telephone.

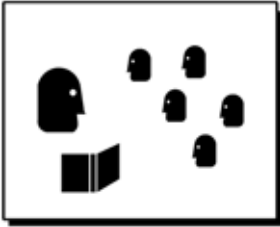

Know your responsibilities as an Employer

- Make certain your employees know how to operate the equipment.
- Make certain your employees are aware of the safety precautions on the equipment and in this manual.
- Make certain that you have thoroughly trained your employees about operating the equipment safely.
- Make certain the equipment is in proper working condition. If you make unauthorized modifications to the equipment, you will reduce the function and safety of the equipment.

Safety Labels

N0158

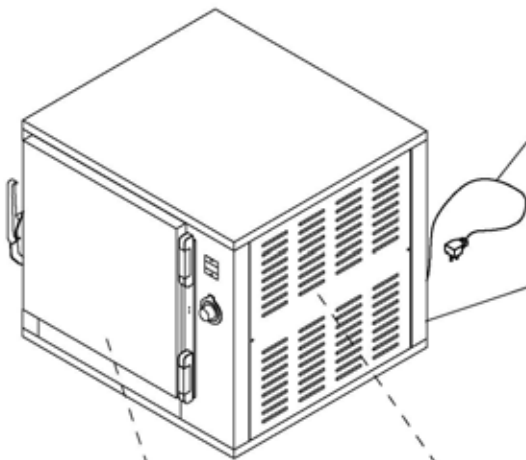

N0202



N0200



N0034



Installation

⚠ WARNING

Serious injury, equipment damage or death could result if attempting to install this unit yourself. Ensure that an authorized BKI service agent installs the unit.

Instructions For Shipping Damage

You are responsible for filing all freight claims with the delivering truck line. Inspect all cartons and crates for damage when they arrive. If there is damage noted to shipping crates or cartons, or, if a shortage is found, note this on the bill of lading (all copies) before signing.

If damage is detected when the equipment is uncrated, immediately call the delivering truck line and follow up the call with a written report indicating concealed damage to your equipment. Ask for an immediate inspection of your concealed damage item. Crating material **MUST** be retained to show the inspector from the truck line.

Floor Placement

If you plan to use the HHC with mounted casters, follow the steps below.

1. Move the unit to a permanent location allowing 2 inches of clearance on the louvered cover side of machine for air circulation.
2. Lock the swivel casters before using.

Countertop Placement

If you plan to mount the HHC on a countertop, follow the steps below.

1. Remove the casters.
2. Place the HHC on a stainless steel shelf allowing 2 inches of clearance on the louvered cover side of machine for air circulation.
3. Wipe any shipping dust from the machine, using a stainless steel cleaner.
4. Seal the cabinet edges to the shelf using an FDA approved silicone sealant.

Electrical Information

⚠ WARNING

Electrocution, equipment failure or property damage could result if an unlicensed electrician performs the electrical installation. Ensure that a licensed electrician perform the electrical installation in accordance with local codes, or in the absence of local codes, with the National Electrical Code, ANSI NFPA 70-20XX.

This unit, when installed by an authorized BKI service agent, must be wired for use in accordance with all applicable local, state, and federal codes. For specific electrical requirements and connections refer to the wiring diagram attached to the unit or provided in the Service Manual.

Replacement Parts

Use the information in this section to identify replacement parts. To order replacement parts, call your local BKI sales and service representative. Before calling, please note the serial number on the rating tag affixed to the unit.

Assemblies & Components

Figure 1. HHC/HHC-T Assemblies & Components

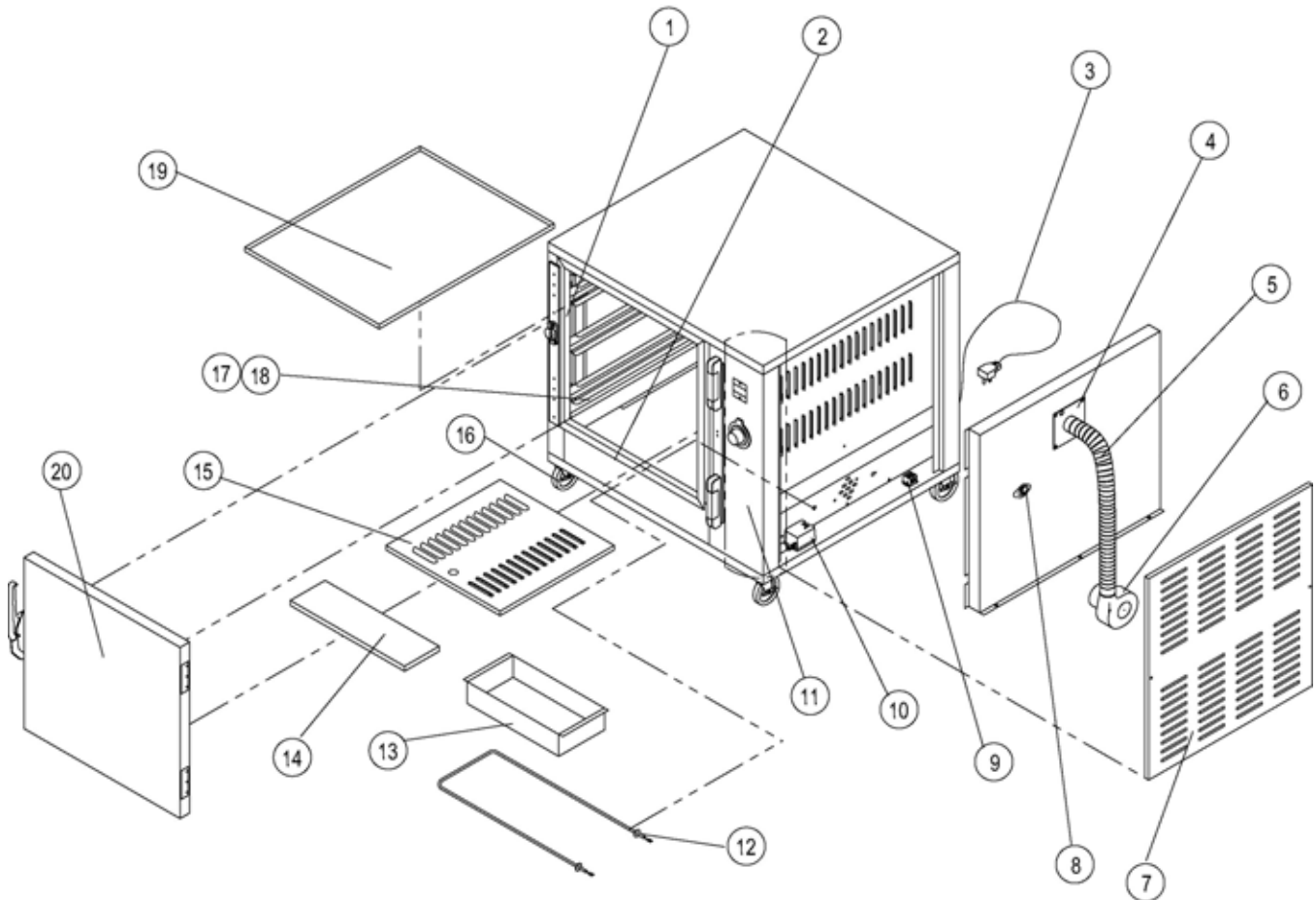

Table 1. HHC/HHC-T Assemblies & Components List

PART #	QTY	DESCRIPTION	FIGURE (ITEM #)	TABLE
DF0154	2	EXTRUSION, DOOR FRAME HHC	Figure 1 (1)	Table 1
DF0155	2	EXTRUSION, DOOR FRAME HHC	Figure 1 (2)	Table 1
CS0032	1	CORD SET, 120V 8' 15A PLUG	Figure 1 (3)	Table 1
SB5407	1	BLOWER HOSE BRKT WELD, LW2 HHC	Figure 1 (4)	Table 1
TU0003 or TU0008	1	TUBING, FLEX 1 1/2 CWY (HHC) or TUBING, FLEX 1 1/2 CWY (HHC-T)	Figure 1 (5)	Table 1
M0030	1	MOTOR, DAYTON 2C782	Figure 1 (6)	Table 1
HHCA004 or FB38003803	1	MOTOR COVER, LOUVERED HHC or LOUVERED END COVER HHC-T	Figure 1 (7)	Table 1
T0057	1	THERMOSTAT, HI LIMIT 2E253B	Figure 1 (8)	Table 1
TB0025-2	1	TERM BLOCK, 202SPSE	Figure 1 (9)	Table 1
TF0035	1	TRANSFORMER, 230V 50/60HZ (HHC only)	Figure 1 (10)	Table 1
	1	CONTROL PANEL ASSY	Figure 1 (11) Figure 2	Table 1 Table 2
C0275 or C0316	1	CALROD, 120V 1700W (HHC or HHC-T) or CALROD, 240V 1700W (HHC only)	Figure 1 (12)	Table 1
FB38001902 or WHHCA002	1	WATER PAN HHC-2D (HHC-T only) or WATER PAN CORNERS WELDED (HHC or HHC-T)	Figure 1 (13)	Table 1
HHCA001	2	LID, HHC	Figure 1 (14)	Table 1
DPCA059	1	LOUVER LID, R INSIDE CAB DPC	Figure 1 (15)	Table 1
C0415	4	CASTER, 3"SWIVEL W/BREAK	Figure 1 (16)	Table 1
SB3853	1	RACK WELD ASSY LH, HHC	Figure 1 (17)	Table 1
SB3854	1	RACK WELD ASSY RH, HHC (Not Shown)	Figure 1 (18)	Table 1
WHHCA003	3	WELD CORNERS HHC ROAST PAN	Figure 1 (19)	Table 1
SB3850 or AN38004000	1	DOOR ASSY, HHC or DOOR ASSY, HHCT	Figure 1 (20) Figure 3	Table 1 Table 3

Figure 2. Control Panel

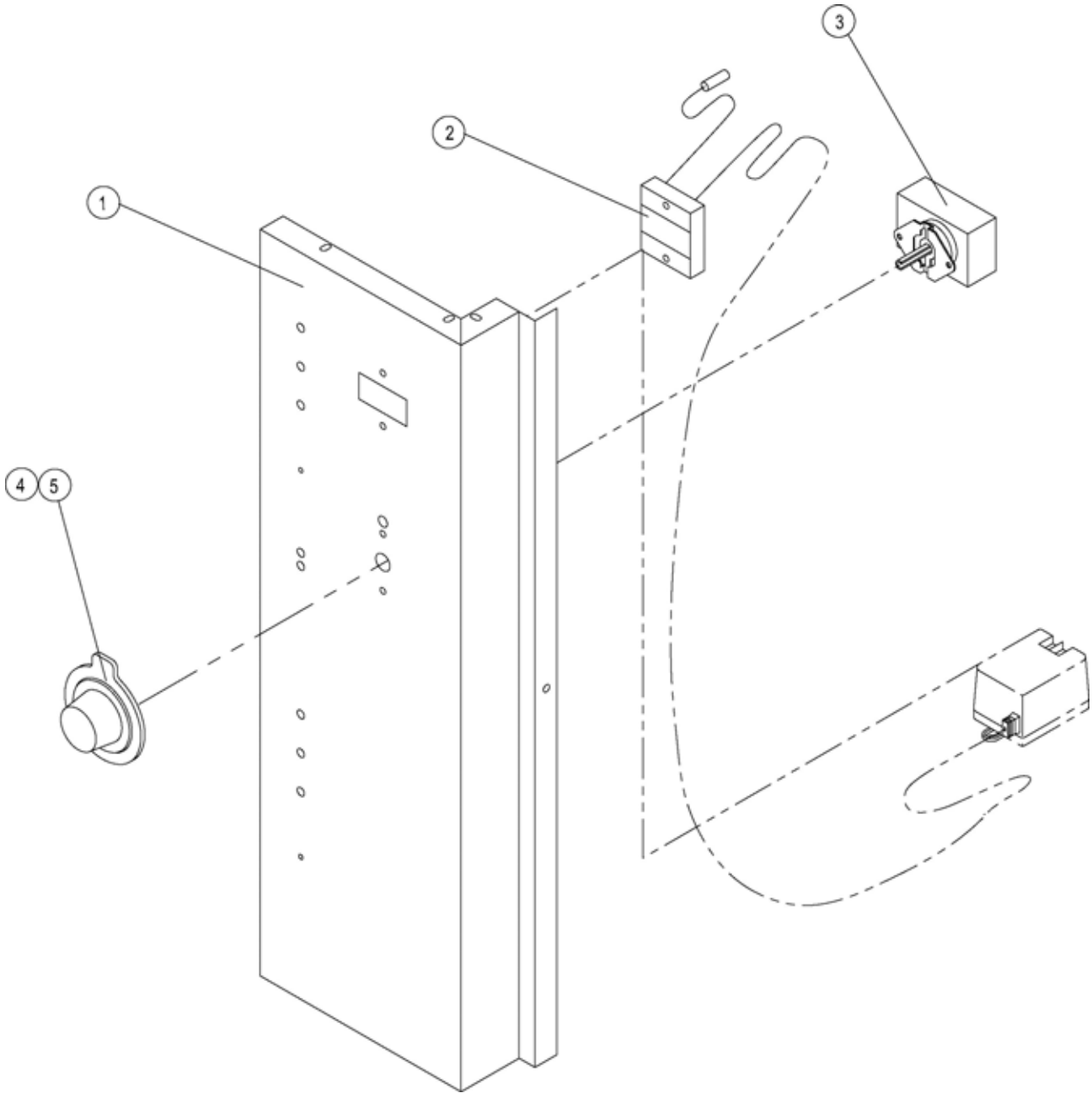

Table 2. Control Panel Parts

ITEM #	PART #	QTY	DESCRIPTION
1	HHCA017 or FB38003303	1	CONTROL PANEL, HHC or CONTROL PANEL, HHC-T
2	TG0026 or TG0014	1	THERMO METER, DIGITAL W/TRANS 220V (HHC) or THERMOMETER, DIGITAL W/TRANSF. (HHC or HHC-T)
3	T0031	1	THERMOSTAT, 60-250 DEG SGL POLE (HHC or HHC-T)
4	K0019	1	KNOB, T-STAT BLK 1-10
5	B1050	1	BEZEL, ROBERTSHAW THERMOSTAT

Figure 3. Door Assembly

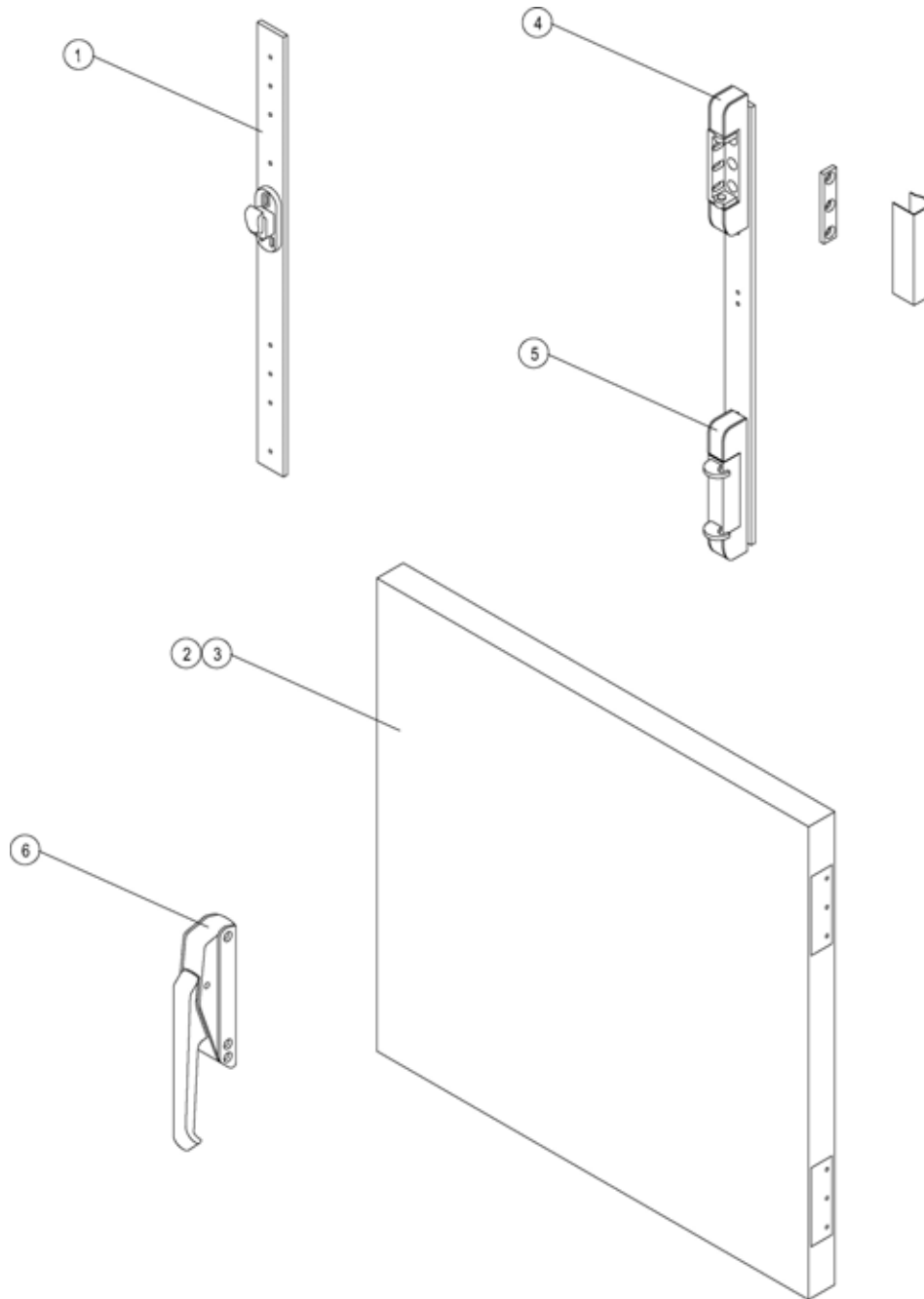

Table 3. Door Assembly Parts

ITEM #	PART #	QTY	DESCRIPTION
1	HHCA022	1	DOOR LATCH BLOCK
2	SB3856 or AN38004500	1	DOOR WELD HHC or DOOR WELD HHCT
3	HHCA014	1	DOOR, INSIDE
4	H0058	1	HINGE, DOOR HHC NO STOP
5	H0057	1	HINGE, DOOR W/STOP
6	L0035	1	LATCH, #174-B CHROME HHC

Wiring Diagrams

Refer to the table below to find the wiring diagram associated with your unit.

Wiring Diagram	Part #	Figure #
HHC 240V/1 Phase	HHCE1003	Figure 4
HHC 120V/1 Phase	HHCE1001	Figure 5
HHC-T 120V/1 Phase	SA38090000	Figure 6

Figure 4. HHC 240V/1 Phase

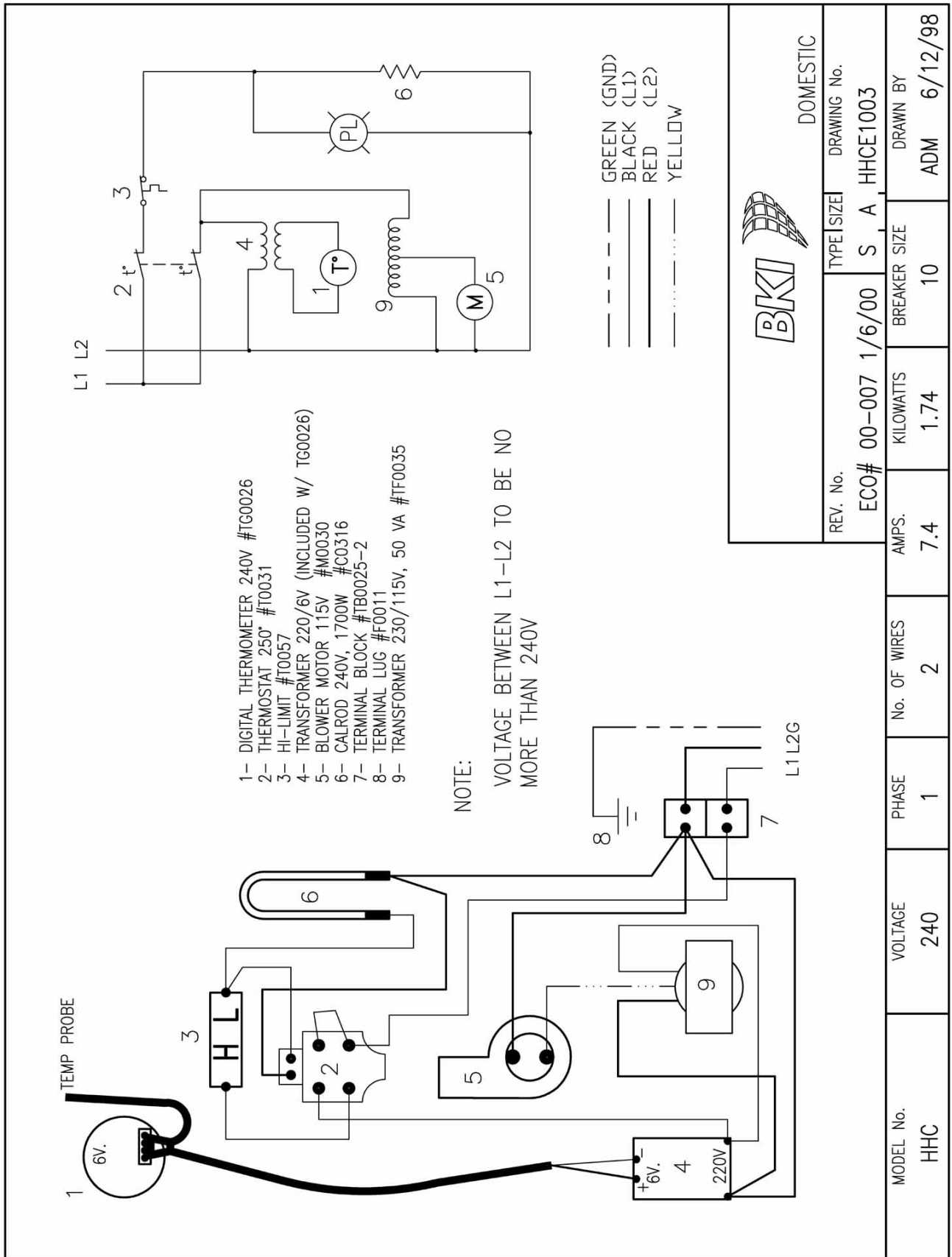

Figure 5. HHC 120V/1 Phase

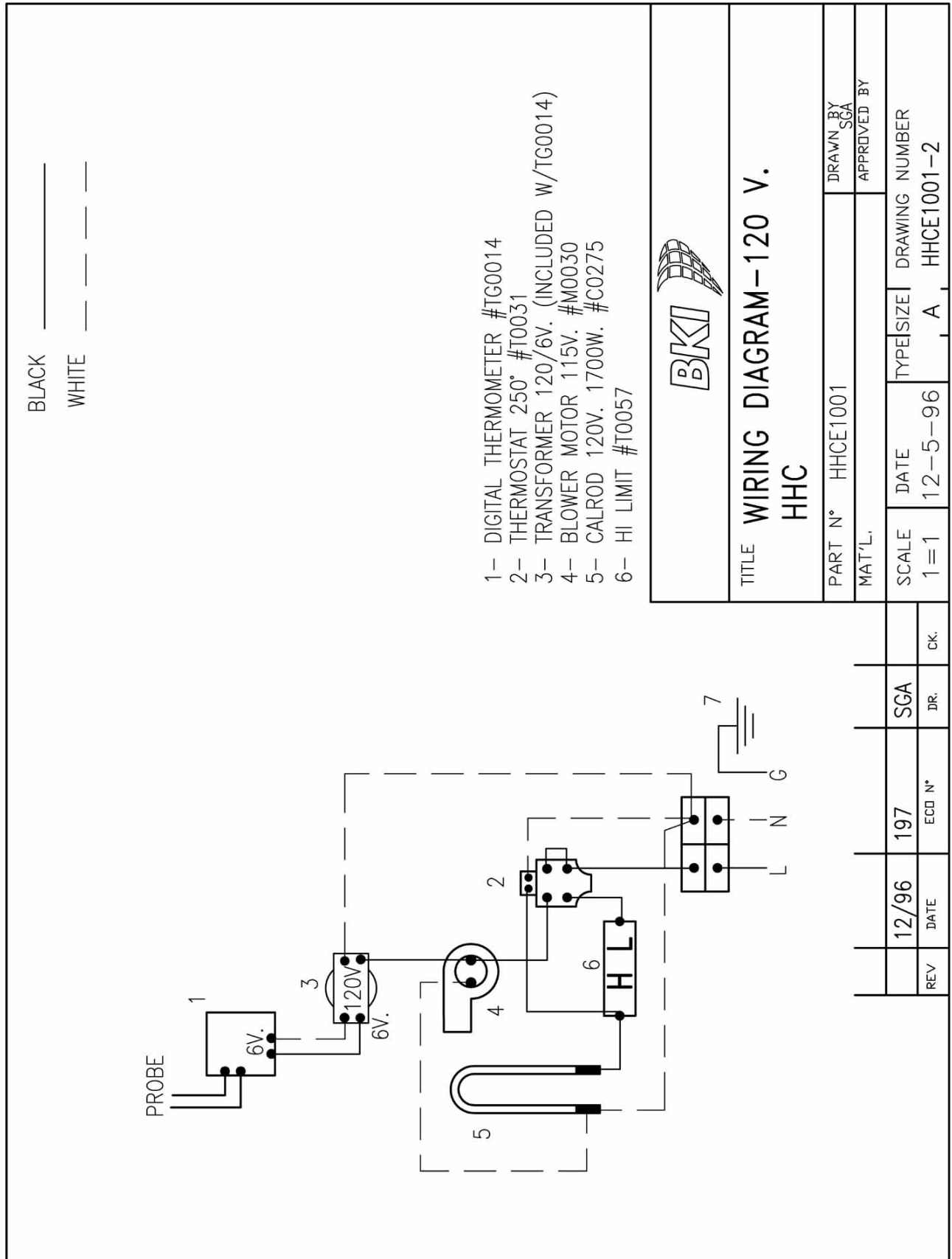
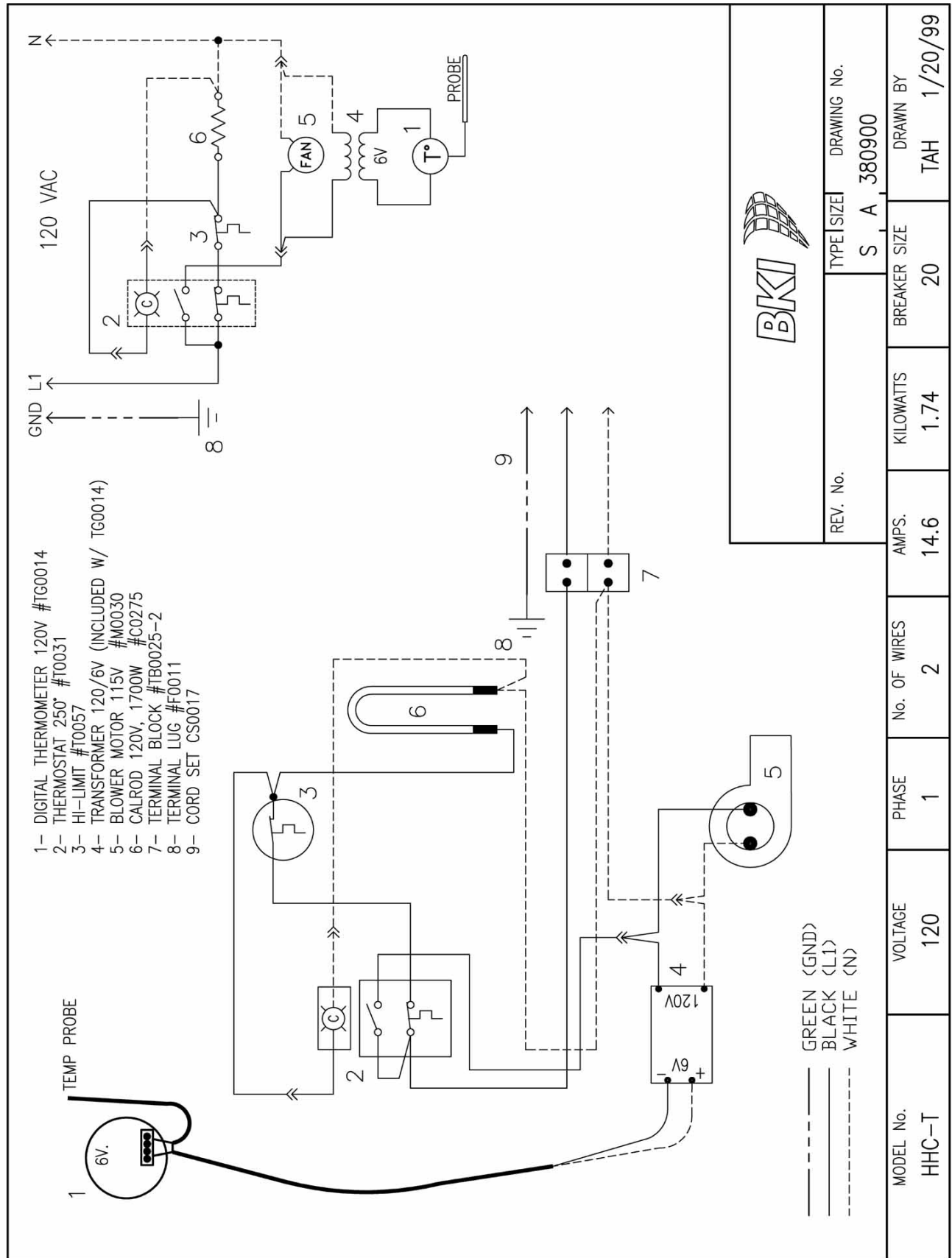

Figure 6. HHC-T 120V/1 Phase





P.O. Box 80400, Simpsonville, S.C. 29680-0400, USA
<http://www.bkideas.com>

Made and printed in the U.S.A
LI0265/1104