



Countertop Sandwich and Fried Food Warmer Series

Series: SFW

Operation Manual



BKI LIMITED WARRANTY

2812 Grandview Dr. • Simpsonville, SC 29680 • USA
(864) 963-3471 • Toll Free: (800) 927-6887 • Fax: (864) 963-5316

WHAT IS COVERED

This warranty covers defects in material and workmanship under normal use, and applies only to the original purchaser providing that:

- The equipment has not been accidentally or intentionally damaged, altered or misused;
- The equipment is properly installed, adjusted, operated and maintained in accordance with national and local codes, and in accordance with the installation and operating instructions provided with this product.
- The serial number rating plate affixed to the equipment has not been defaced or removed.

WHO IS COVERED

This warranty is extended to the original purchaser and applies only to equipment purchased for use in the U.S.A.

COVERAGE PERIOD

- Warranty claims must be received in writing by BKI within one (1) year from date of installation or within one (1) year and three (3) months from data of shipment from the factory, whichever comes first.
- COB Models: One (1) Year limited parts and labor.
- COM Models: Two (2) Year limited parts and labor. COM convection ovens also have a two (2) year door warranty.
- CO1 Models: Two (2) Year limited parts and labor. Five (5) Year limited door warranty.
- BevLes Products: Two (2) Year limited parts and labor.
- Warranty period begins the date of dealer invoice to customer or ninety (90) days after shipment date from BKI, whichever comes first.

WARRANTY COVERAGE

This warranty covers on-site labor, parts and reasonable travel time and travel expenses of the authorized service representative up to (100) miles round trip and (2) hours travel time and performed during regular, weekday business hours.

EXCEPTIONS

Any exceptions must be pre-approved in advance and in writing by BKI. The extended door warranty on convection ovens years 3 through 5 is a parts only warranty and does not include labor, travel, mileage or any other charges.

EXCLUSIONS

- Negligence or acts of God,
- Thermostat calibrations after (30) days from equipment installation date,
- Air and gas adjustments,
- Light bulbs,
- Glass doors and door adjustments,
- Fuses,
- Adjustments to burner flames and cleaning of pilot burners,
- Tightening of screws or fasteners,
- Failures caused by erratic voltages or gas suppliers,
- Unauthorized repair by anyone other than a BKI Factory Authorized Service Center,
- Damage in shipment,
- Alteration, misuse or improper installation,
- Thermostats and safety valves with broken capillary tubes,
- Freight - other than normal UPS charges,
- Ordinary wear and tear,
- Failure to follow installation and/or operating instructions,
- Events beyond control of the company.

INSTALLATION

Leveling, as well as proper installation and check out of all new equipment - per appropriate installation and use materials - is the responsibility of the dealer or installer, not the manufacturer.

REPLACEMENT PARTS

BKI genuine Factory OEM parts receive a (90) day materials warranty effective from the date of installation by a BKI Factory Authorized Service Center.

Table of Contents

Table of Contents	1
Introduction	2
Safety Precautions	2
Safety Signs and Messages	2
Safe Work Practices	3
Safety Labels	5
Installation	6
Instructions For Shipping Damage	6
Electrical Information And Grounding	6
Installation Instructions	7
Right-Sided SFW	7
Left-Sided SFW	8
Left-Sided SFW-72	9
FW-15L	10
Operation	12
Controls and Indicators	12
Unit Startup and Preheating	13
SFW	13
FW-15L	14
Sandwich Warmer Temperature Adjustment	14
Operational Guidelines	14
Unit Shutdown	14
SFW	14
FW-15L	14
Maintenance	15
Scheduled Maintenance	15
SFW Cleaning	15
FW-15L Cleaning	15
Troubleshooting	16
Repair	17
Lamp Replacement	17
Notes	18

BKI Worldwide is a wholly owned subsidiary of Standex International Corporation.

Introduction

Congratulations! You have chosen a **Sandwich/Fry Warmer** that will give you many years of fine service from the original manufacturer, **BKI**.

The **BKI** name and trademark on this unit assures you of the finest in design and engineering — that it has been built with care and dedication — using the best materials available. Attention to the operating instructions regarding proper installation, operation, and maintenance will result in long lasting dependability to insure the highest profitable return on your investment.

NOTICE

PLEASE READ THIS ENTIRE MANUAL BEFORE OPERATING THE UNIT. If you have any questions, please contact your **BKI** Distributor. If they are unable to answer your questions, contact the **BKI** Technical Service Department, toll free: 1-800-927-6887. Outside the U.S., call 1-864-963-3471.

Safety Precautions

Always follow recommended safety precautions listed in this manual. Below is the safety alert symbol. When you see this symbol on your equipment, be alert to the potential for personal injury or property damage.

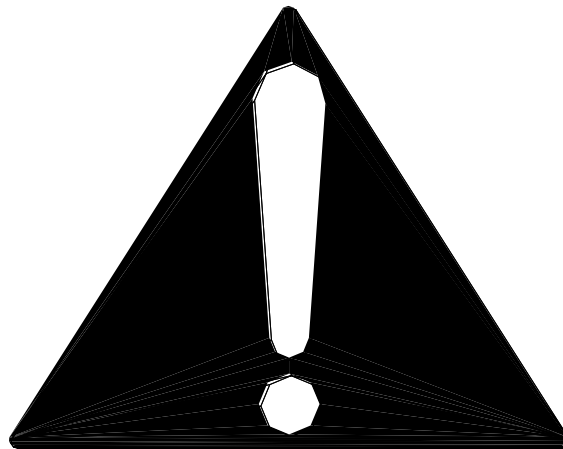

Safety Signs and Messages

The following Safety signs and messages are placed in this manual to provide instructions and identify specific areas where potential hazards exist and special precautions should be taken. Know and understand the meaning of these instructions, signs, and messages. Damage to the equipment, death or serious injury to you or other persons may result if these messages are not followed.

⚠ DANGER

This message indicates an imminently hazardous situation that, if not avoided, will result in death or serious injury.

⚠ WARNING

This message indicates a potentially hazardous situation, which, if not avoided, could result in death or serious injury.

⚠ CAUTION

This message indicates a potentially hazardous situation, which, if not avoided, may result in minor or moderate injury. It may also be used to alert against unsafe practices.

NOTICE

This message is used when special information, instructions or identification are required relating to procedures, equipment, tools, capacities and other special data.

Safe Work Practices

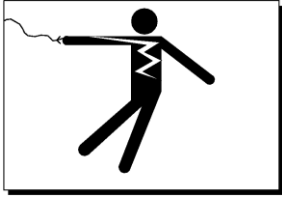

Beware of High Voltage

This equipment uses high voltage. Serious injury can occur if you or any untrained or unauthorized person installs, services, or repairs this equipment. Always Use an Authorized Service agent to Service Your Equipment.

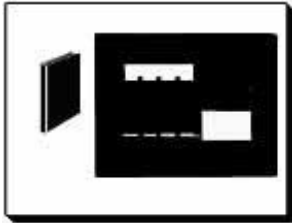

Keep this manual with the Equipment

This manual is an important part of your equipment. Always keep it near for easy access. If you need to replace this manual, contact:

BKI

Technical Services Department
2812 Grandview Drive
Simpsonville, S.C. 29680
Or call toll free: 1-800-927-6887
Outside the U.S., call 864-963-3471



Protect Children

Keep children away from this equipment. Children may not understand that this equipment is dangerous for them and others.

NEVER allow children to play near or operate your equipment.

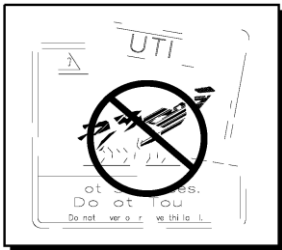

Keep Safety Labels Clean and in Good Condition

Do not remove or cover any safety labels on your equipment. Keep all safety labels clean and in good condition. Replace any damaged or missing safety labels. Refer to the Safety Labels section for illustration and location of safety labels on this unit. If you need a new safety label, obtain the number of the specific label illustrated on page 4, then contact:

BKI

Technical Services Department
2812 Grandview Drive
Simpsonville, S.C. 29680
Or call toll free: 1-800-927-6887
Outside the U.S., call 864-963-3471

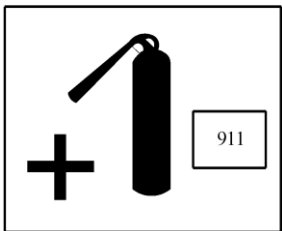

Be Prepared for Emergencies

Be prepared for fires, injuries, or other emergencies.

Keep a first aid kit and a fire extinguisher near the equipment. You must use a 40-pound Type BC fire extinguisher and keep it within 25 feet of your equipment.

Keep emergency numbers for doctors, ambulance services, hospitals, and the fire department near your telephone.

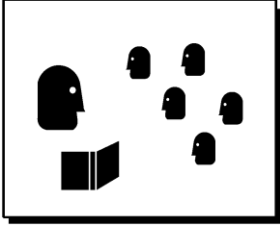
**Know your responsibilities as an Employer**

- Make certain your employees know how to operate the equipment.
- Make certain your employees are aware of the safety precautions on the equipment and in this manual.
- Make certain that you have thoroughly trained your employees about operating the equipment safely.
- Make certain the equipment is in proper working condition. If you make unauthorized modifications to the equipment, you will reduce the function and safety of the equipment.



California Residents Only. This product can expose you to chemicals including chromium, and lead which are known to the State of California to cause cancer and birth defects or other reproductive harm. For more information go to www.P65Warnings.ca.gov.

Safety Labels

CAUTION

This product has two power supply cords. Connect each plug to a receptacle that is connected to an individual branch circuit. Unplug both cords before moving or servicing this appliance.

N0660

N0444

This lamp has been treated to resist breakage and must be replaced with a similarly treated lamp in order to maintain compliance with NSF standards.

N0444

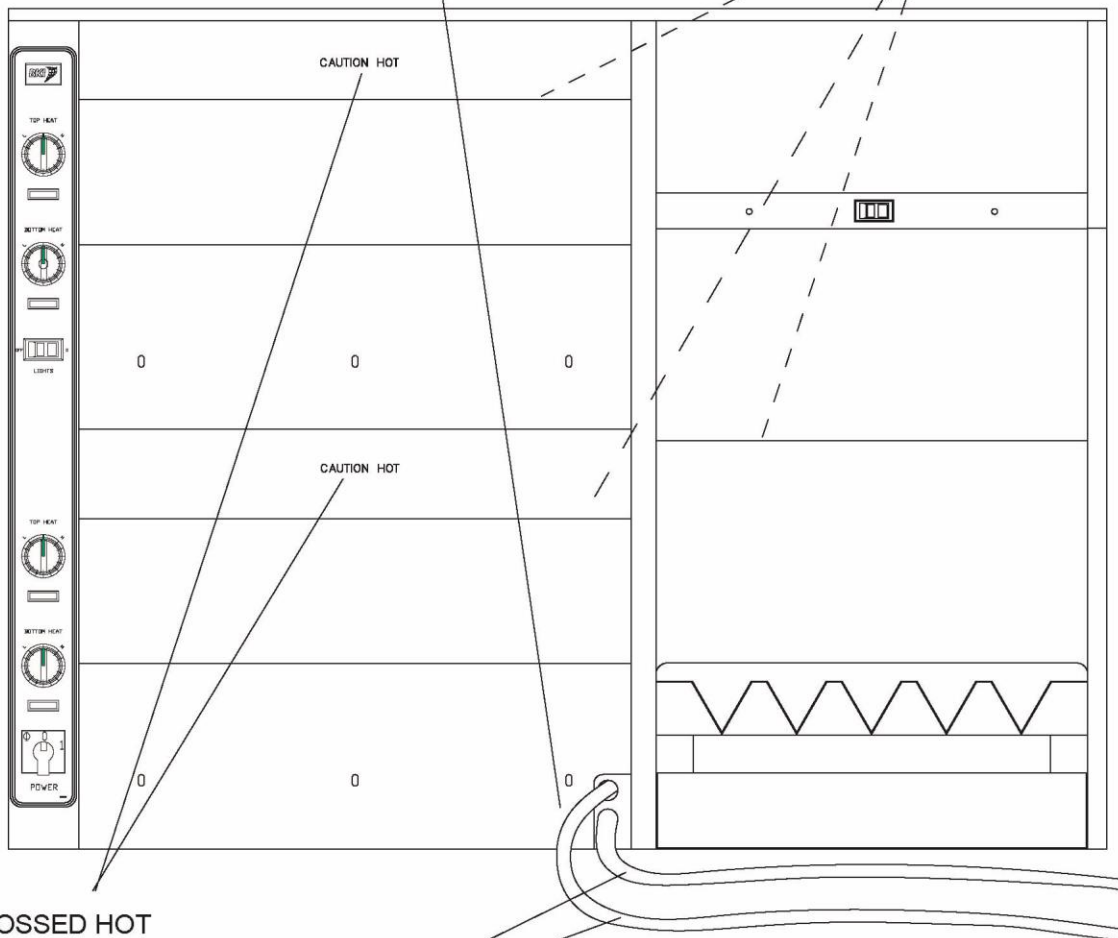

EMBOSSED HOT SURFACE CAUTION

N0158

WARNING
CONNECT ONLY TO APPROVED 3 PRONG GROUNDED CIRCUIT. FAILURE TO DO SO COULD RESULT IN SERIOUS INJURY.

WARNING
CONNECT ONLY TO APPROVED 3 PRONG GROUNDED CIRCUIT. FAILURE TO DO SO COULD RESULT IN SERIOUS INJURY.

DO NOT COVER OR REMOVE THIS LABEL

N0158

Installation

⚠ WARNING

Serious injury, equipment damage or death could result if attempting to install this unit yourself. Ensure that an authorized BKI service agent installs the unit.

Instructions For Shipping Damage

You are responsible for filing all freight claims with the delivering truck line. Inspect all cartons and crates for damage when they arrive. If there is damage noted to shipping crates or cartons, or, if a shortage is found, note this on the bill of lading (all copies) before signing.

If damage is detected when the equipment is uncrated, immediately call the delivering truck line and follow up the call with a written report indicating concealed damage to your equipment. Ask for an immediate inspection of your concealed damage item. Crating material **MUST** be retained to show the inspector from the truck line.

Electrical Information And Grounding

⚠ WARNING

Electrocution, equipment failure or property damage could result if an unlicensed electrician performs the electrical installation. Ensure that a licensed electrician perform the electrical installation in accordance with local codes, or in the absence of local codes, with the National Electrical Code, ANSI NFPA 70-20XX.

This unit, when installed by an authorized BKI service agent, must be wired for use in accordance with all applicable local, state, and federal codes. For specific electrical requirements and connections refer to the wiring diagram attached to the unit or provided in the Service Manual.

The SFW has two power supply cords. Unplug both cords before moving, testing, or servicing.

Individual branch circuits are to be used to supply power. Each power supply cord needs a separate 20A circuit breaker.

Installation Instructions

Right-Sided SFW

1. Obtain a suitable countertop location and place the entire unit in position.
2. Measure, mark and cut a hole in the countertop for the Fry Warmer blower pan to fit in according to the following drawing.

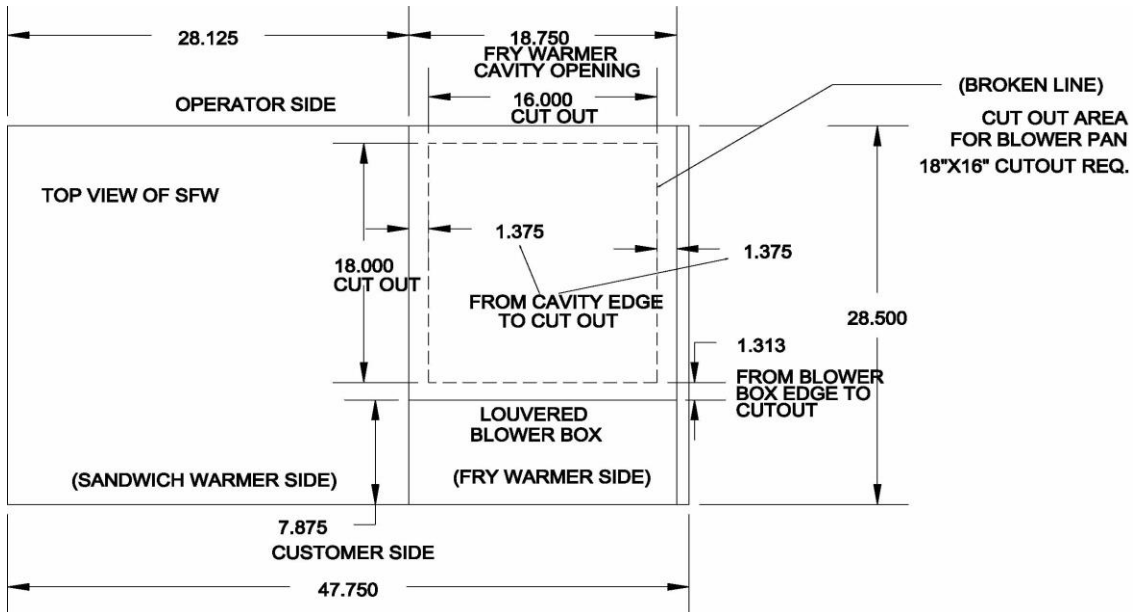

3. Place the blower pan into the hole making sure that open side of the pan fits over the two tabs on the louvered blower box.
4. Place the perforated pan insert into the blower pan.

Left-Sided SFW

1. Obtain a suitable countertop location and place the entire unit in position.
2. Measure, mark and cut a hole in the countertop for the Fry Warmer blower pan to fit in according to the following drawing.

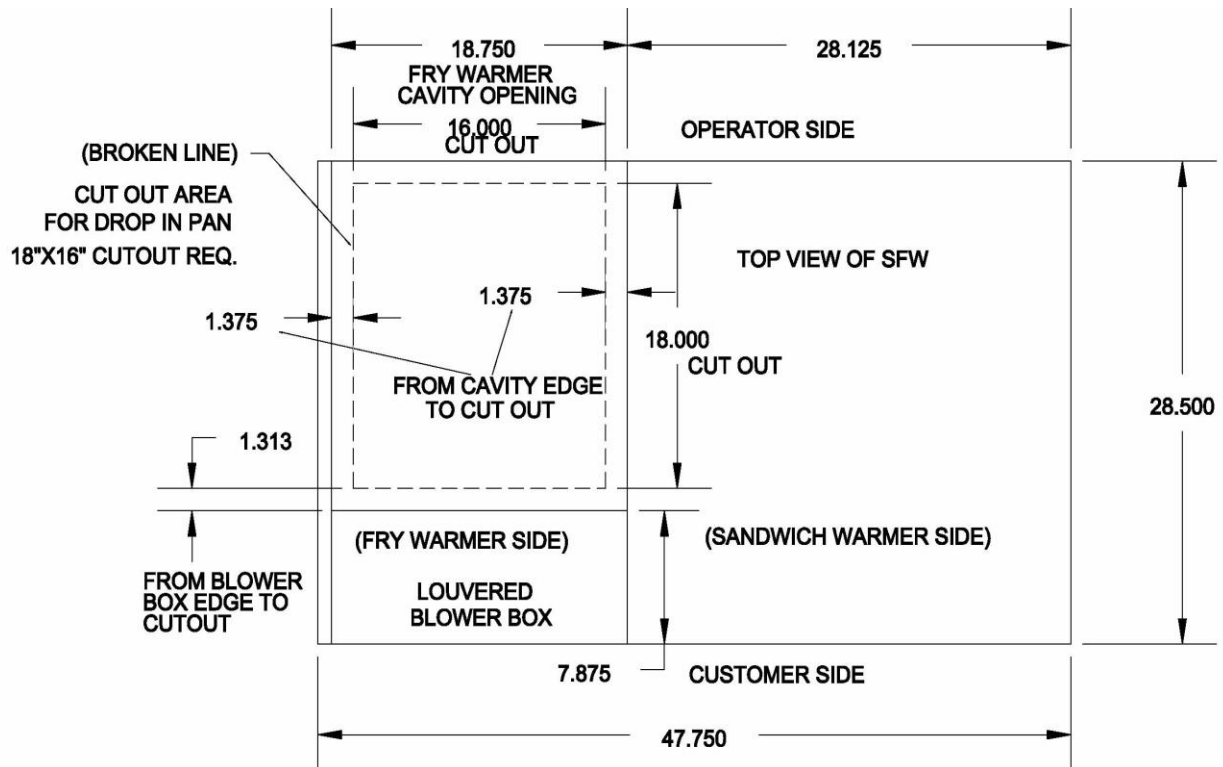

3. Place the blower pan into the hole making sure that open side of the pan fits over the two tabs on the louvered blower box.
4. Place the perforated pan insert into the blower pan.

Left-Sided SFW-72

1. Obtain a suitable countertop location and place the entire unit in position.
2. Measure, mark and cut a hole in the countertop for the Fry Warmer blower pan to fit in according to the following drawing.

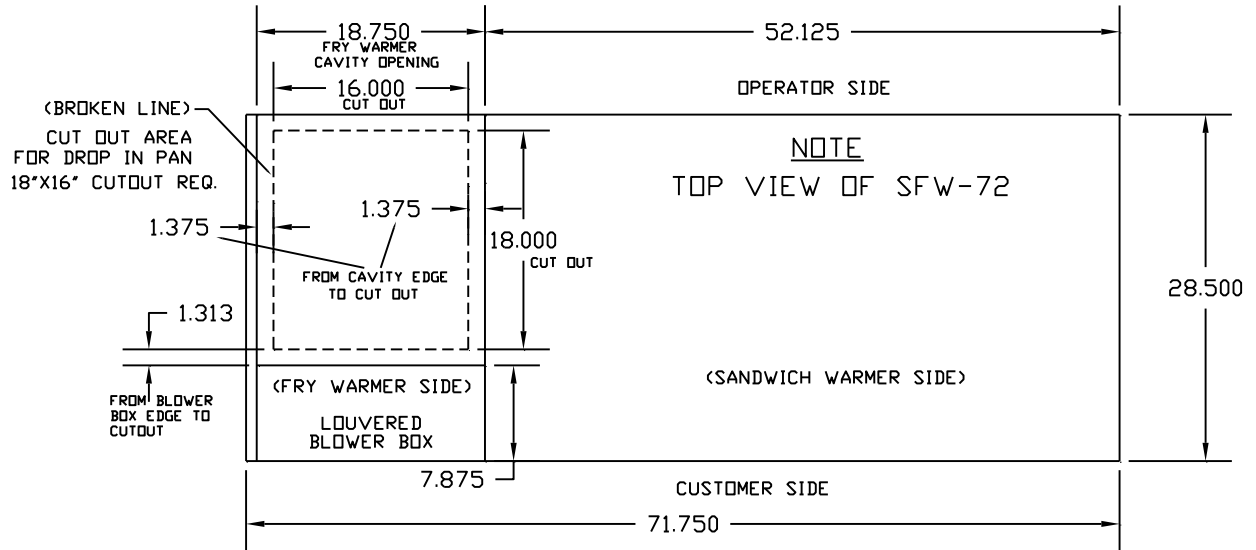

3. Place the blower pan into the hole making sure that open side of the pan fits over the two tabs on the louvered blower box.
4. Place the perforated pan insert into the blower pan.

FW-15L

1. Obtain a suitable countertop location for the unit that will provide a clearance of 4" from the side louvers.
2. Cut a hole in the countertop to fit the collar weldment according to the drawing below.

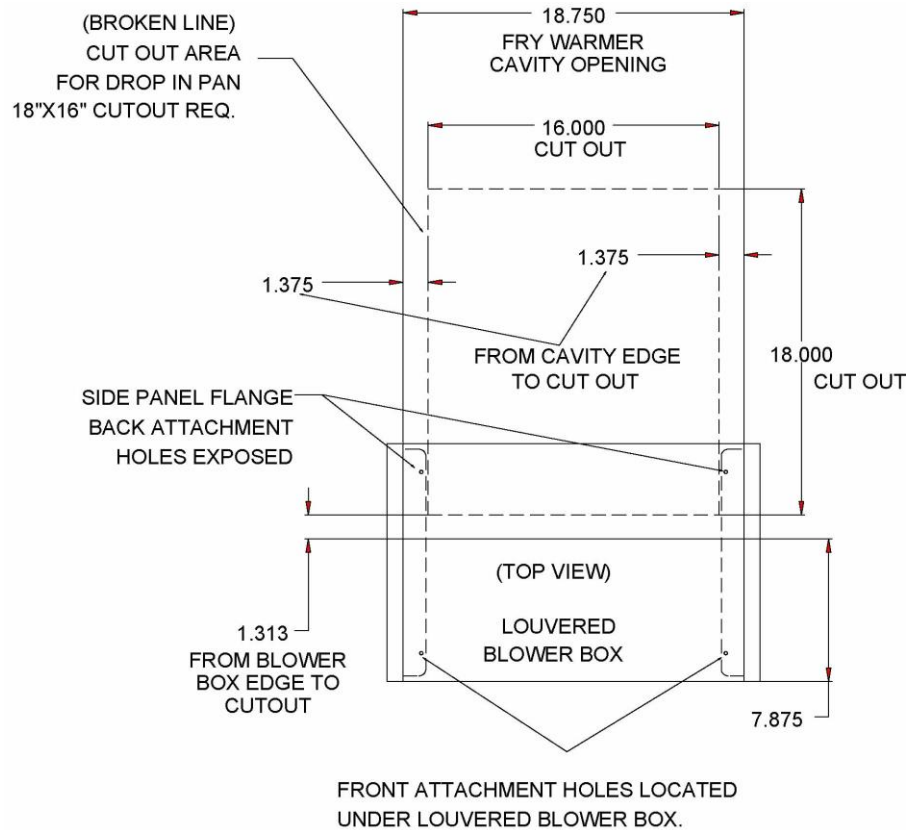

3. Using a 2" hole saw, drill a hole in the countertop (under where the louvered blower box will be positioned) for the power cord to pass through.
4. Position collar weldment into the cutout area with slotted holes toward the main unit.
5. Position the main unit as shown above ensuring that the side panel flanges are under the flanges of the collar weldment.
6. Line up the back attachment holes on the flanges of the main unit with the slotted holes in the flanges of the collar weldment.
7. Remove the louvered blower box to access the front attachment holes by unscrewing 7 screws shown below.

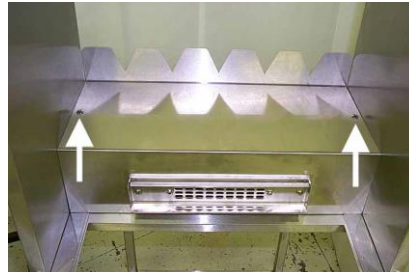

8. Using a 1/8" drill bit, drill holes in countertop through existing holes in the main unit and collar weldment flanges.
9. Secure main unit and collar weldment to countertop using #8 sheet metal screws.
10. Feed power cord (supplied), down through hole in countertop.
11. Reattach louvered blower box to main unit.
12. Seal main unit to the countertop to conform to NSF Standard 4, Item 4.28. (Dow Corning RTV #732 Multi purpose Sealant.)
13. Place the blower pan into the hole making sure that open side of the pan fits over the two tabs on the louvered blower box.
14. Place the perforated pan insert into the blower pan.

Operation

Controls and Indicators

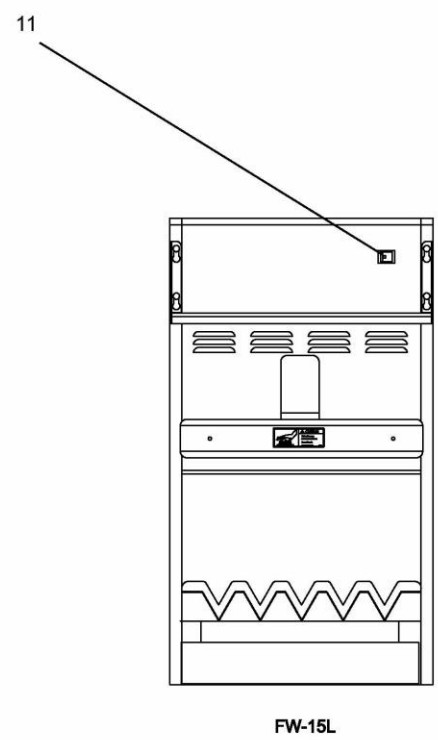
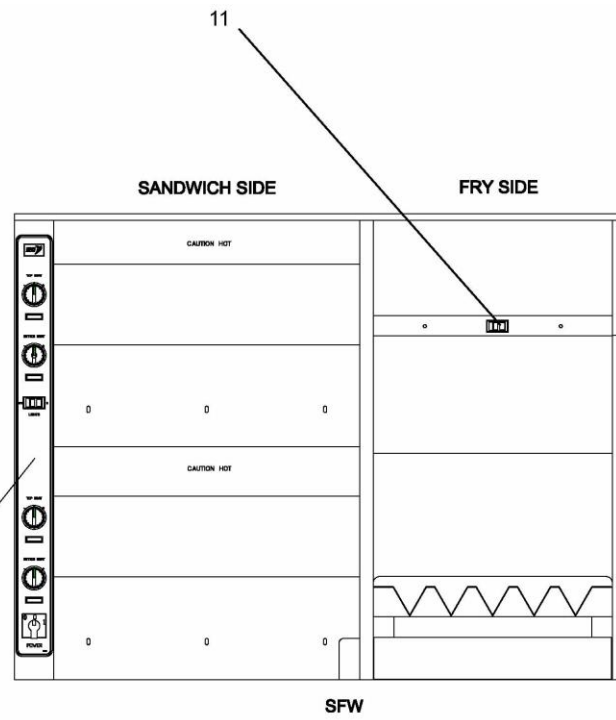
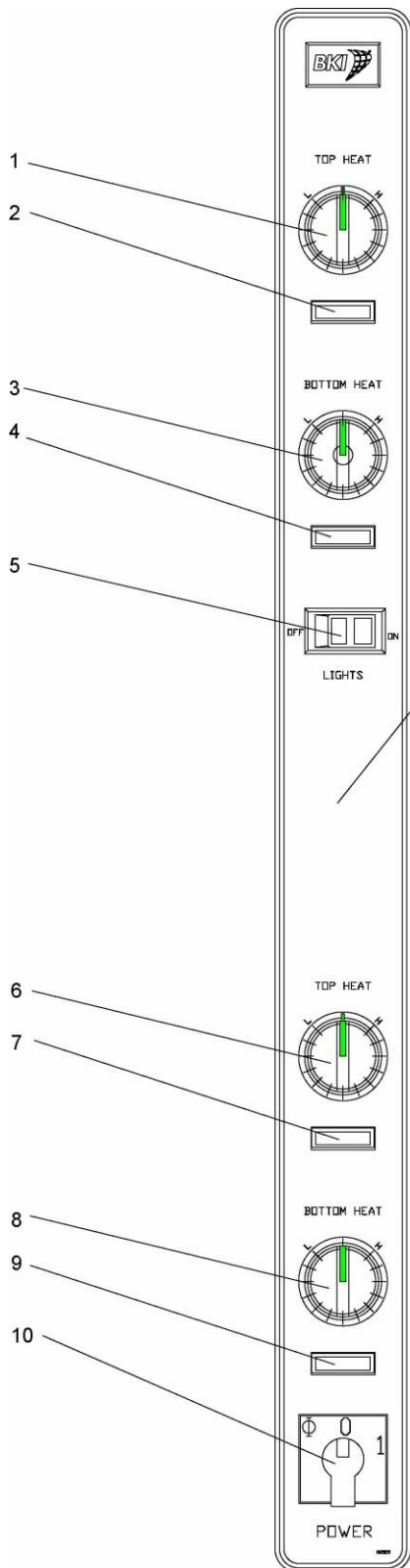

Item #	Description	Function
1	Upper Sandwich Warmer TOP HEAT temperature control	Controls the temperature of the Upper Sandwich Warmer ceramic heaters.
2	Upper Sandwich Warmer TOP HEAT pilot light	Cycles on and off to indicate when the Upper Sandwich Warmer ceramic heaters turn on and off.
3	Upper Sandwich Warmer BOTTOM HEAT temperature control	Controls the temperature of the Upper Sandwich Warmer heating element.
4	Upper Sandwich Warmer BOTTOM HEAT pilot light	Cycles on and off to indicate when the Upper Sandwich Warmer heating element turns on and off.
5	LIGHTS ON/OFF Switch for Upper and Lower Sandwich Warmer	Controls power to the Sandwich Warmer lights.
6	Lower Sandwich Warmer TOP HEAT temperature control	Controls the temperature of the Lower Sandwich Warmer ceramic heaters.
7	Lower Sandwich Warmer TOP HEAT pilot light	Cycles on and off to indicate when the Lower Sandwich Warmer ceramic heaters turn on and off.
8	Lower Sandwich Warmer BOTTOM HEAT temperature control	Controls the temperature of the Lower Sandwich Warmer heating element.
9	Lower Sandwich Warmer BOTTOM HEAT pilot light	Cycles on and off to indicate when the Lower Sandwich Warmer heating element turns on and off.
10	Sandwich Warmer POWER ON/OFF Switch	Controls power to the upper and lower Sandwich Warmers.
11	Fry Warmer ON/OFF Switch	Controls power to the entire Fry Warmer.

Unit Startup and Preheating

SFW

1. Connect the plugs of the power cords into receptacles that match the power rating specified on the rating tag.
2. Place the Fry Warmer ON/OFF switch to the ON (1) position. The switch should illuminate red, the bulb should light and the chute and perforated pan should begin to heat up.
3. Place the Sandwich Warmer **POWER ON/OFF** switch to the ON (1) position.
4. Place the **TOP HEAT** and **BOTTOM HEAT** temperature control knobs on each sandwich warmer (upper and lower) to the number 5 position. The pilot lights will cycle on and off to maintain proper sandwich warmer temperature.
5. Place the Sandwich Warmer **LIGHTS ON/OFF** switch to the **ON** (1) position. The switch should illuminate red.
6. Allow the equipment to preheat for 30 minutes before loading it with product.

FW-15L

1. Connect the plug of the power cord into a receptacle that matches the power rating specified on the rating tag.
2. Place the Fry Warmer ON/OFF switch to the ON (1) position. The switch should illuminate red, the bulb should light and the chute and perforated pan should begin to heat up.
3. Allow the equipment to preheat for 30 minutes before loading it with product.

Sandwich Warmer Temperature Adjustment

After loading the unit with product, it may be necessary to adjust the temperature control knobs in order to maintain the proper internal temperature for the product on display. The temperature control knobs should be set to the lowest possible number that will maintain the proper product temperature.

Operational Guidelines

- Foods should be a minimum of 160° F. before being placed in the warmer.
- Foods loaded in first should be served first as much as is practical.
- Check Federal and State Health and Sanitation Regulations for internal temperature required for holding cooked foods for sale. Maintaining these temperatures often tends to continue to cook certain products. Therefore, smaller amounts of bulk foods should be displayed at non-peak periods and the warmer refilled as needed.

NOTICE

This equipment is designed to hold foods for a short period of time only.

Unit Shutdown**SFW**

1. Remove all food from the equipment.
2. Place the Fry Warmer ON/OFF switch to the OFF (0) position.
3. Place the Sandwich Warmer **POWER** ON/OFF switch to the OFF (0) position.
4. Allow the equipment to cool to room temperature.
5. Remove any residue and clean the equipment thoroughly.

FW-15L

1. Remove all food from the equipment.
2. Place the Fry Warmer ON/OFF switch to the OFF (0) position.
3. Allow the equipment to cool to room temperature.
4. Remove any residue and clean the equipment thoroughly.

Maintenance

⚠ CAUTION

Failure to comply with the maintenance below could result in a serious accident.

⚠ WARNING

Electrocution, equipment failure or property damage could result if an unlicensed electrician performs electrical repair. Ensure that a licensed electrician perform electrical repair.

Scheduled Maintenance

This unit should be cleaned at the end of each working day. Use the following procedure:

⚠ DANGER

Failure to remove power from this unit may cause severe electrical shock. This unit may have more than one disconnect switch.

⚠ CAUTION

Never use abrasive cleaners that may damage the finish.

Never steam clean the interior.

Avoid getting excess water in the interior of the unit.

Do not clean the heater/blower assembly by applying compressed air.

Do not leave this unit on and unattended after business hours.

SFW Cleaning

1. Remove all food from the unit.
2. Place the Fry Warmer ON/OFF switch to the OFF (0) position.
3. Place the Sandwich Warmer **POWER** ON/OFF switch to the OFF (0) position.
4. Unplug both power cords.
5. Allow the equipment to cool to room temperature.
6. Remove and clean the Fry Warmer blower pan and pan insert.
7. Clean around the slotted holes at the air discharge on the blower box.
8. Clean the air intakes using a mild soap and water solution.
9. Sponge the inside and outside of the unit with a mild soap and water solution, being sure to clean all areas. Avoid getting water in the interior of the unit.
10. Wipe the parts and unit dry with a soft, clean cloth and replace the blower pan and pan insert.

FW-15L Cleaning

1. Remove all food from the unit.
2. Place the Fry Warmer ON/OFF switch to the OFF (0) position.
3. Unplug the power cord.

4. Allow the equipment to cool to room temperature.
5. Remove and clean the Fry Warmer blower pan and pan insert.
6. Clean around the slotted holes at the air discharge on the blower box.
7. Clean the air intakes using a mild soap and water solution.
8. Sponge the inside and outside of the unit with a mild soap and water solution, being sure to clean all areas. Avoid getting water in the interior of the unit.
9. Wipe the parts and unit dry with a soft, clean cloth and replace the blower pan and pan insert.

Troubleshooting

Problem	Cause	Possible Solution
Sandwich Warmer and/or Fry Warmer will not turn on.	Power cords not connected or circuit breaker supplying power to the unit has tripped.	Make sure power cords are connected and circuit breaker is on. If problem persists contact a licensed electrician.
Product is not holding it's temperature	Product temperature is too low when loaded. Or Faulty component in heating circuit	Make sure product is above 160° F when loaded. Contact an authorized BKI service agent for corrective action.
Fry Warmer		
Warmer chute is not heating and perforated pan is not heating	No power to unit.	Make sure that the circuit breaker at the power supply is on and the Fry Warmer main power switch is on. If problem persists, contact licensed electrician.
Warmer chute is heating and the perforated pan is not heating	Fan has overheated and cut off Or Heating coil has failed	Wipe the dust from the air intake louvers to allow proper airflow and prevent fan overheating. Turn the power switch off. Wait 60 seconds. Turn the power switch back on. Contact an authorized BKI service agent for corrective action.
Noisy fan	Fan blade is dirty or fan bearings are failing	Contact an authorized BKI service agent for corrective action.
Warmer chute is not holding heat	Ceramic heating element failure	Contact an authorized BKI service agent for corrective action.
Sandwich Warmer		
Warmer is not heating	No power to unit Or Faulty component in top or bottom heating circuit.	Make sure that the circuit breaker at the power supply is on and the Sandwich Warmer main power switch is on. If problem persists, contact licensed electrician. Contact an authorized BKI service agent for corrective action.

Repair

NOTICE

Before replacing any parts, make sure the power has been turned off and the unit has cooled down.

Lamp Replacement

NOTICE

Only use PTFE-coated lamp to prevent glass contamination.

1. Make sure power to the unit is OFF and the unit has cooled down.
2. Carefully remove the faulty lamp.
3. Replace with the new lamp.

Notes

Notes



2812 Grandview Dr., Simpsonville, S.C. 29680, USA
<http://www.bkideas.com>

Made and printed in the U.S.A