



High Capacity Rotisserie Oven Series

SERIES: VGG

Operation Manual



BKI LIMITED WARRANTY

**2812 Grandview Dr. • Simpsonville, SC 29680 • USA
(864) 963-3471 • Toll Free: (800) 927-6887 • Fax: (864) 963-5316**

WHAT IS COVERED	<p>This warranty covers defects in material and workmanship under normal use, and applies only to the original purchaser providing that:</p> <ul style="list-style-type: none"> <input type="checkbox"/> The equipment has not been accidentally or intentionally damaged, altered or misused; <input type="checkbox"/> The equipment is properly installed, adjusted, operated and maintained in accordance with national and local codes, and in accordance with the installation and operating instructions provided with this product. <input type="checkbox"/> The serial number rating plate affixed to the equipment has not been defaced or removed.
WHO IS COVERED	<p>This warranty is extended to the original purchaser and applies only to equipment purchased for use in the U.S.A.</p>
COVERAGE PERIOD	<ul style="list-style-type: none"> <input type="checkbox"/> Warranty claims must be received in writing by BKI within one (1) year from date of installation or within one (1) year and three (3) months from data of shipment from the factory, whichever comes first. <input type="checkbox"/> COB Models: One (1) Year limited parts and labor. <input type="checkbox"/> COM Models: Two (2) Year limited parts and labor. COM convection ovens also have a two (2) year door warranty. <input type="checkbox"/> CO1 Models: Two (2) Year limited parts and labor. Five (5) Year limited door warranty. <input type="checkbox"/> Warranty period begins the date of dealer invoice to customer or ninety (90) days after shipment date from BKI, whichever comes first.
WARRANTY COVERAGE	<p>This warranty covers on-site labor, parts and reasonable travel time and travel expenses of the authorized service representative up to (100) miles round trip and (2) hours travel time and performed during regular, weekday business hours.</p>
EXCEPTIONS	<p>Any exceptions must be pre-approved in advance and in writing by BKI. The extended door warranty on convection ovens years 3 through 5 is a parts only warranty and does not include labor, travel, mileage or any other charges.</p>
EXCLUSIONS	<ul style="list-style-type: none"> <input type="checkbox"/> Negligence or acts of God, <input type="checkbox"/> Thermostat calibrations after (30) days from equipment installation date, <input type="checkbox"/> Air and gas adjustments, <input type="checkbox"/> Light bulbs, <input type="checkbox"/> Glass doors and door adjustments, <input type="checkbox"/> Fuses, <input type="checkbox"/> Adjustments to burner flames and cleaning of pilot burners, <input type="checkbox"/> Tightening of screws or fasteners, <input type="checkbox"/> Failures caused by erratic voltages or gas suppliers, <input type="checkbox"/> Unauthorized repair by anyone other than a BKI Factory Authorized Service Center, <input type="checkbox"/> Damage in shipment, <input type="checkbox"/> Alteration, misuse or improper installation, <input type="checkbox"/> Thermostats and safety valves with broken capillary tubes, <input type="checkbox"/> Freight - other than normal UPS charges, <input type="checkbox"/> Ordinary wear and tear, <input type="checkbox"/> Failure to follow installation and/or operating instructions, <input type="checkbox"/> Events beyond control of the company.
INSTALLATION	<p>Leveling, as well as proper installation and check out of all new equipment - per appropriate installation and use materials – is the responsibility of the dealer or installer, not the manufacturer.</p>
REPLACEMENT PARTS	<p>BKI genuine Factory OEM parts receive a (90) day materials warranty effective from the date of installation by a BKI Factory Authorized Service Center.</p>

Table of Contents

Table of Contents	1
Introduction	2
Safety Precautions	2
Safety Signs and Messages	2
Specific Precautions	3
Safe Work Practices	3
Safety Labels	5
Health and Sanitation Practices	5
Food Handling	5
Storage of Raw Meats	5
Coding Cooked Foods	5
Storage of Prepared Foods	5
Operation	6
Controls and Indicators	6
Hardware Controls	6
Configuring the CTS Oven Controller	7
Changing Access Code	9
Importing Recipe & Configuration Files	9
Exporting Recipe, Configuration and History Files	9
Exporting Recipe, Configuration and History Files (continued)	10
Setting the Clock	10
Viewing the Error and Event History File	10
Cooking with the CTS Oven Controller	11
Configuring the CTS Controller for use in the VGG Oven	13
Controller Errors, Warnings and Events	15
Errors	15
Warnings and Alarms	15
Events	16
Accessory Use	17
Trussing Chickens	17
V-Spits	18
Standard Meat forks	18
Baskets	18
Installation	19
Unpacking and Handling	19
Location and Clearance	19
Extraction	19
Wiring	19
General Guidelines	19
Guidelines for European Appliances	22
Operating	22
Safety Cut-Out	22
Maintenance	23
Scheduled Maintenance	23
Oven Cleaning (Daily)	23
Troubleshooting	26
Accessories	28
Wiring Diagrams	29
NOTES	36

BKI Worldwide is a wholly owned subsidiary of Standex International Corporation.

Introduction

Your **BKI** VGG is a computer controlled rotisserie oven. It utilizes a revolving mechanism and heating elements that ensure even product cooking. A touchscreen control and switches are provided to allow for quick setup and operation. Removable components allow for easy maintenance and cleaning.

The **BKI** name and trademark on this unit assures you of the finest in design and engineering -- that it has been built with care and dedication -- using the best materials available. Attention to the operating instructions regarding proper installation, operation, and maintenance will result in long lasting dependability to ensure the highest profitable return on your investment.

NOTICE

PLEASE READ THIS ENTIRE MANUAL BEFORE OPERATING THE UNIT. If you have any questions, please contact your BKI Distributor. If they are unable to answer your questions, phone the applicable BKI Technical Services Department:

BKI

Technical Services Department
2812 Grandview Drive
Simpsonville, S.C. 29680
Or call toll free: 1-800-927-6887
Outside the U.S., call 864-963-3471

Safety Precautions

Always follow recommended safety precautions listed in this manual. Below is the safety alert symbol. When you see this symbol on your equipment, be alert to the potential for personal injury or property damage.



Safety Signs and Messages

The following Safety signs and messages are placed in this manual to provide instructions and identify specific areas where potential hazards exist and special precautions should be taken. Know and understand the meaning of these instructions, signs, and messages. Damage to the equipment, death or serious injury to you or other persons may result if these messages are not followed.

⚠ DANGER

This message indicates an imminently hazardous situation which, if not avoided, will result in death or serious injury.

⚠ WARNING

This message indicates a potentially hazardous situation, which, if not avoided, could result in death or serious injury.

⚠ CAUTION

This message indicates a potentially hazardous situation, which, if not avoided, may result in minor or moderate injury. It may also be used to alert against unsafe practices.

NOTICE

This message is used when special information, instructions or identification are required relating to procedures, equipment, tools, capacities and other special data.

Specific Precautions

CAUTION

Equipotential Ground Plane

When a high current flows through a conductor, differences in potential appear between the conductor and nearby metallic surfaces near the appliance. As a result, sparks may be produced between the appliance and surrounding metal surfaces. These sparks could cause serious injury, damage, or fire.

BKI provides an Equipotential ground terminal for the connection of a bonding conductor after the installation of the appliance per IEC60417-1. This terminal is located on the drive side of the oven base and is marked with this symbol.



NOTICE

Full Disconnection for IEC / CE Regulations

In accordance with Local and/or National wiring codes, the installer must provide a means of full disconnection for overvoltage Category III conditions. An IEC approved cord and plug combination will meet this requirement.

Units not provided with a cord and plug do not meet this requirement. In accordance with Local and/or National wiring codes, the installer must provide the means of full disconnection.

WARNING

California Residents Only. This product can expose you to chemicals including chromium, and lead which are known to the State of California to cause cancer and birth defects or other reproductive harm. For more information go to www.P65Warnings.ca.gov.

Safe Work Practices

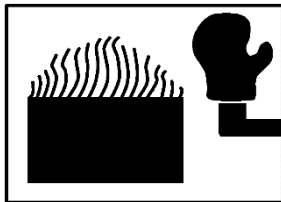

Wear Safe Clothing Appropriate To Your Job

Always wear your insulated mitts when handling hot oven parts or touch any hot metal surface. If you lose or damage your mitts, you can buy new ones at your local restaurant equipment supply store or from your local **BKI** Distributor.

Always wear non-skid shoes when working around the oven or any other equipment.

Never wear loose clothing such as neckties or scarves while operating this equipment. Keep loose hair tied back or in a hair net while operating this equipment.

Always wear appropriate personal protection equipment during the cleaning process to guard against possible injury.

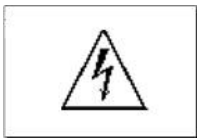

WARNING – DANGEROUS VOLTAGE

This equipment uses high voltage. Serious injury can occur if you or any untrained or unauthorized person installs, services, or repairs this equipment. Always Use an Authorized Service agent to Service Your Equipment.

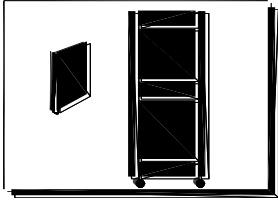

Keep this manual with the Equipment

This manual is an important part of your equipment. Always keep it near for easy access. If you need to replace this manual, phone the applicable BKI Technical Services Department:

BKI
 Technical Services Department
 2812 Grandview Drive
 Simpsonville, S.C. 29680
 Or call toll free: 1-800-927-6887
 Outside the U.S., call 864-963-3471



Protect Children

Keep children away from this equipment. Children may not understand that this equipment is dangerous for them and others.

NEVER allow children to play near or operate your equipment.

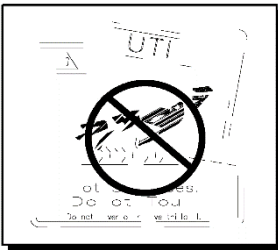

Keep Safety Labels Clean and in Good Condition

Do not remove or cover any safety labels on your equipment. Keep all safety labels clean and in good condition. Replace any damaged or missing safety labels. Refer to the Safety Labels section for illustration and location of safety labels on this unit. If you need a new safety label, obtain the number of the specific label illustrated on page 5, then phone the applicable BKI Technical Services Department:

BKI
 Technical Services Department
 2812 Grandview Drive
 Simpsonville, S.C. 29680
 Or call toll free: 1-800-927-6887
 Outside the U.S., call 864-963-3471

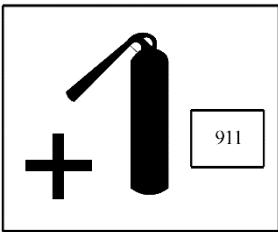

Be Prepared for Emergencies

Be prepared for fires, injuries, or other emergencies.

Keep a first aid kit and a fire extinguisher near the equipment. You must use a 40-pound Type BC fire extinguisher and keep it within 25 feet of your equipment.

Keep emergency numbers for doctors, ambulance services, hospitals, and the fire department near your telephone.

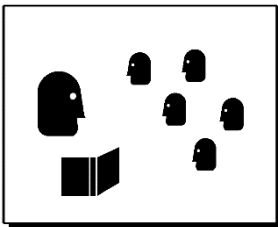

Know your responsibilities as an Employer

- Make certain your employees know how to operate the equipment.
- Make certain your employees are aware of the safety precautions on the equipment and in this manual.
- Make certain that you have thoroughly trained your employees about operating the equipment safely.
- Make certain the equipment is in proper working condition. If you make unauthorized modifications to the equipment, you will reduce the function and safety of the equipment.

Safety Labels

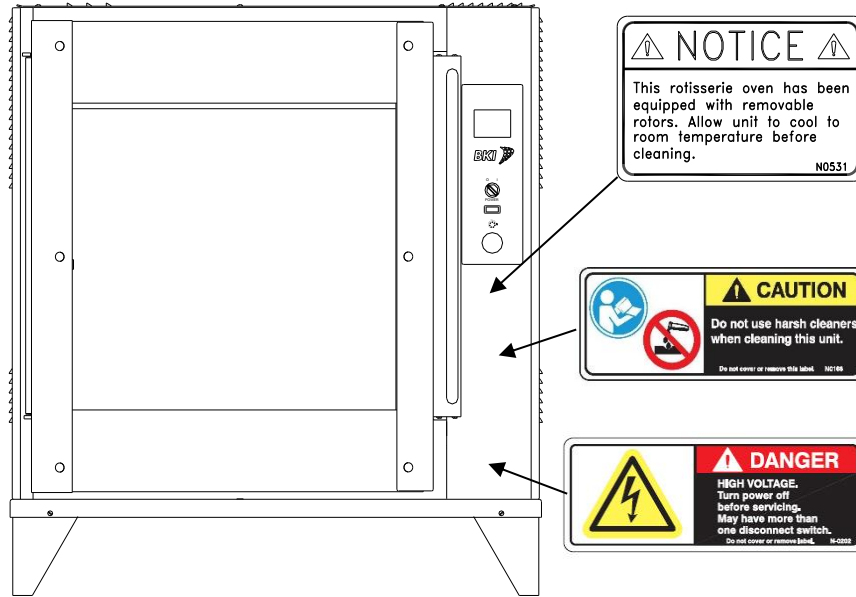

Health and Sanitation Practices

BKI Rotisserie Ovens are manufactured to comply with health regulations and are tested and certified to NSF standards. You must operate the equipment properly, using only quality products and use meat thermometers to insure meats are thoroughly cooked.

Food Handling

- Wash hands thoroughly in warm, soapy water after handling raw poultry or meats.
- Clean and sanitize all utensils and surfaces that have been in contact with raw products. Clean and sanitize the meat forks or baskets between cooking.
- **Never** place cooked meats on the same surfaces used to prepare raw meats, unless the area has been thoroughly cleaned and sanitized.

Storage of Raw Meats

- Designate an area or shelf strictly for the storage of all raw meats to be used in the rotisserie.
- Raw product must always be stored at temperatures below 38° F. (3° C.).
- Never store or mix raw foods above cooked foods, as this is a health hazard. The drippings from raw foods contaminate cooked or processed foods.
- All chicken and chicken parts to be stored overnight must be thoroughly iced down and refrigerated.
- Never put raw foods into the oven with cooked or partially cooked foods, as this is a health hazard. The drippings from raw foods contaminate cooked foods.

Coding Cooked Foods

All products cooked during the day should be sold the same day.

NOTE: It is not the intent of the rotisserie program to have unsold merchandise at the end of the cooking day. Follow your company's procedures for the handling of any leftover product.

Storage of Prepared Foods

- Cold foods should be kept at or below 38° F. (3° C.).
- Hot foods must be maintained to meet local health codes, usually a minimum 145° F. (63° C.).

Operation



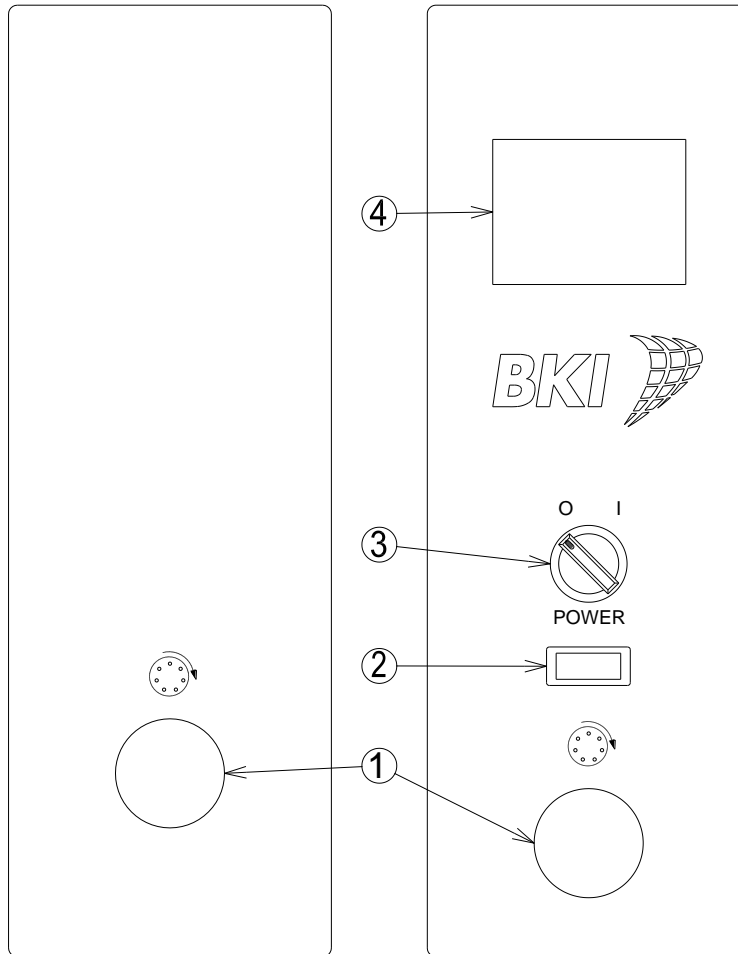

Controls and Indicators





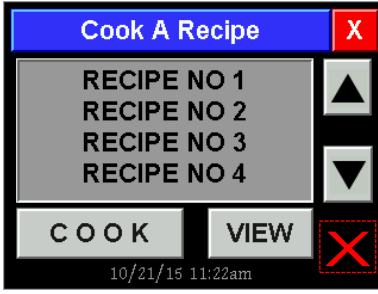

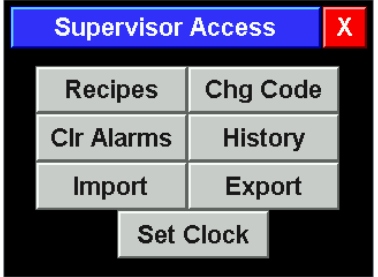

Hardware Controls

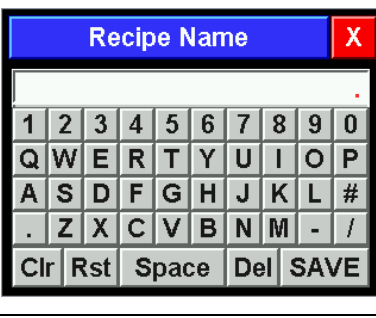
Item #	Description	Function
1	Rotor Switch	Depressing the switch allows the operator to “jog” the rotor position when the door is open. Releasing the switch stops the rotor.
2	Main Power Isolator Light	This light illuminates to indicate that power is being applied to the oven from the Main Power Isolator (Circuit Breaker).
3	Main Power Switch	Turns power to the entire unit on or off. When placed in the on position, the Touchscreen controller is powered, lights illuminate and the rotor motor engages (if both doors are closed). When placed in the off position, power is removed from the entire unit.
4	Color Touchscreen Controller	Used for operation and programming of the oven. A built-in beeper is used to indicate touchscreen presses and other oven functions. It has 15 programmable cooking recipes.

Configuring the CTS Oven Controller

Configuration Access		
<p>Touch and hold the lower right portion of the screen until the control chirps twice.</p>		<p>The area on the control screen is black. The red graphic in this diagrams indicates the area to touch and hold.</p>
<p>Enter your access code. Touch [X] to exit and return to Main Recipe screen.</p>	 <p>[Delete] clears the last character. [Clear] clears all characters.</p>	<p>The default Supervisor access code is 1234. Use the default code the first time the Configuration is accessed. The access code can be changed after initial access to configuration (recommended). Write the new access code below and keep this manual where only supervisors have access to it.</p> <p>Access Code _____</p> <p>Use the screen keypad to enter the access code then touch [ENTER].</p>
<p>Supervisor level configuration screen is displayed. Touch [X] to exit and return to Main Recipe screen.</p>		<p>The supervisor has access to change Recipes, change the Access Code, Set the Clock, Import or Export recipes and configurations or view the control History. Touch the desired function button and follow the configuration instructions below.</p>
Recipe Editing		
<p>Touch and highlight the desired recipe. Touch [EDIT]. Touch [X] to exit and return to Supervisor Access screen.</p>		<p>There are 15 programmable recipes in the control. Touch [▲] or [▼] to scroll through the list. Touch and highlight the recipe name in the selection window. Touch [EDIT].</p>
<p>Touch and highlight the desired Recipe Item. Touch [EDIT]. Touch [X] to exit and return to Select Recipe screen.</p>		<p>Touch and highlight the Recipe Item to be edited in the selection window. Touch [EDIT]. Once all changes have been made you must touch [SAVE] to store the recipe revisions.</p>

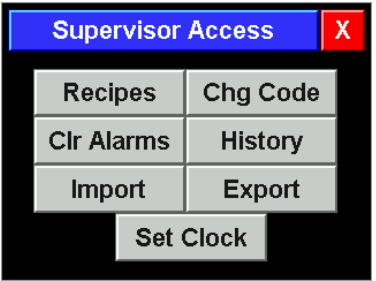
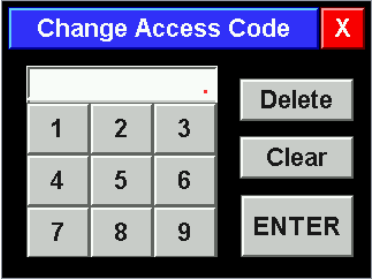
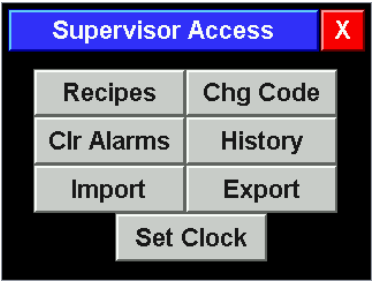
Recipe Editing (continued)		
<p>Edit Recipe Name. Touch [SAVE]. Touch [X] to exit and return to Select Item screen.</p>		<p>Edit the Recipe Name using the alpha-numeric keyboard. Recipe Names are limited to a maximum of 14 characters. Touch [SAVE] to save the new Recipe Name and return to the Select Item screen. [Clr] – Clears the editing box of all characters. [Rst] – Restores the original recipe name. [Space] – Adds a space character at the end. [Del] – Deletes the last character.</p>
<p>Edit Recipe Items. Touch [SAVE]. Touch [X] to exit and return to Select Item screen.</p>		<p>All Recipe Items (Preheat, Cook and Hold) are edited in this screen. Touch [<<] and [>>] to move between the Recipe Items. The value field active for editing has a red background. Touch the inactive field to make it active for editing. The Preheat and Hold items only have a temperature value. The time field for these items is greyed out and not selectable. Use the dial on the right of the screen or the [+] and [-] buttons to change the value. To turn the Cook Cycle 2, Cook Cycle 3 or Hold segments Off, set the temperature value below 150F. Touch [SAVE] to save the new values before moving to the next Recipe Item.</p>
<p>Return to the Select Item screen. Touch [SAVE] to save Recipe. Touch [X] to exit and return to Select Recipe screen.</p>		<p>After Recipe editing is complete, touch [X] on the Recipe Item screen above to return to the Select Item screen. You must touch [SAVE] to store the recipe revisions.</p>
<p>Touch and highlight another Recipe. Touch [EDIT]. or Touch [X] to exit and return to Supervisor Access screen.</p>		<p>Touch and highlight another Recipe name in the selection window. Touch [EDIT]. or Touch [X] to return to the Supervisor Access screen if you are done editing Recipes.</p>

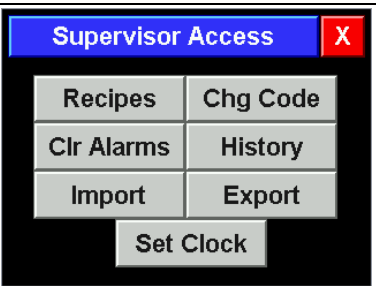
Changing Access Code		
<p>Supervisor level configuration screen is displayed. Touch [X] to exit and return to Main Recipe screen.</p>		<p>Touch [Chg Code].</p>
<p>Enter new Access Code. Touch [ENTER]. Touch [X] to exit and return to Supervisor Access screen.</p>	 <p>[Delete] clears the last character. [Clear] clears all characters.</p>	<p>Use the screen keypad to enter the new 4 digit Access Code. Touch [ENTER]. Record the new Access Code in the area provided in the Configuration Access section of this manual. Once the new Access Code is entered the old code will not provide configuration access.</p>
Importing Recipe & Configuration Files		
<p>Supervisor level configuration screen is displayed. Touch [X] to exit and return to Main Recipe screen.</p>		<p>Supervisor Access gives the ability to Import Recipe and Configuration files from a USB flash drive. Touch [Import].</p>
<p>Insert USB Drive. Touch [Read Recipes] and/or [Read Config]. Touch [X] to exit and return to Supervisor Access screen.</p>		<p>Insert the USB flash drive into the USB port located on the control side of the oven. The message line will change to read "Drive Inserted" and the [Read Recipes] and [Read Config] buttons will become active. Touch [Read Recipes] and/or [Read Config] to upload the files to the control. Remove the USB drive when finished and the control will return to the Supervisor Access screen.</p>
Exporting Recipe, Configuration and History Files		
<p>Supervisor level configuration screen is displayed. Touch [X] to exit and return to Main Recipe screen.</p>		<p>Supervisor Access gives the ability to Export Recipe, Configuration and History files to a USB flash drive. Touch [Export].</p>

Exporting Recipe, Configuration and History Files (continued)

<p>Supervisor level configuration screen is displayed. Touch [X] to exit and return to Main Recipe screen.</p>		<p>Insert the USB flash drive into the USB port located on the control side of the oven. The message line will change to read "Drive Inserted" and the [Save Recipes], [Save Config] [Save History] buttons will become active. Touch [Save Recipes], [Save Config] and/or [Save History] to download the files to the USB drive. Remove the USB drive when finished and the control will return to the Supervisor Access screen.</p>
--	---	---

Setting the Clock

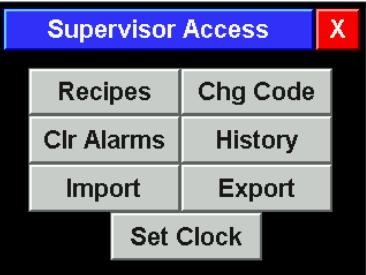
<p>Supervisor level configuration screen is displayed. Touch [X] to exit and return to Main Recipe screen.</p>		<p>The control has a real time clock that will maintain the current date and time for up to 7 days with no power. This information is used for the error and event history log. Touch [Set Clock].</p>
--	---	--

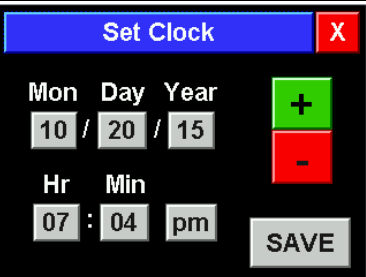

<p>Touch value and change using [+] and [-] buttons. Touch [SAVE] to save and return to Supervisor Access screen.</p>		<p>Touch and highlight the value below the item to be changed. Use the [+] and [-] buttons to change the item to the desired value. To change the am/pm setting simply touch that value to toggle between am and pm. Touch [SAVE] to save the changes. The control will return to the Supervisor Access screen.</p>
---	--	---

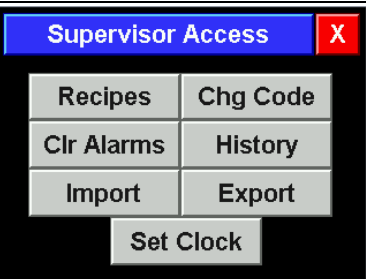

Viewing the Error and Event History File

<p>Supervisor level configuration screen is displayed. Touch [X] to exit and return to Main Recipe screen.</p>		<p>Supervisor Access gives the ability to view the controls History log. The log includes the total numbers of operating hours, the total number of cooking hours and all event and error messages. Touch [History].</p>
--	---	--

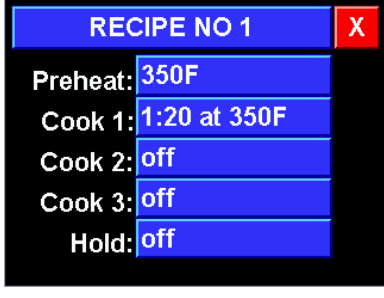
<p>Controller History screen is displayed. Touch [SAVE] to save and return to Supervisor Access screen.</p>		<p>Total: the total number of hours the control has been turned on. Cook: the total number of hours the control has been cooking (includes preheat). Touch [▲] or [▼] to scroll through the list of trackable events and errors. The date, time and a descriptive string are displayed for each event. A list of the errors and events follows in this manual.</p>
---	---	--

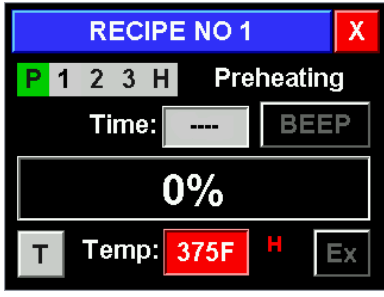

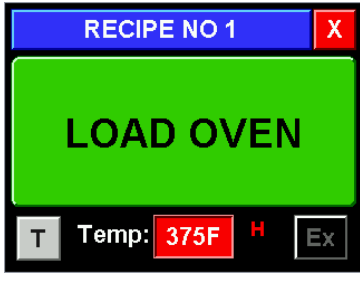
Cooking with the CTS Oven Controller

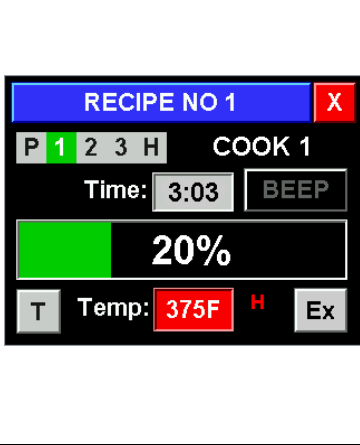
View a Recipe		
<p>Touch and highlight desired recipe. Touch [VIEW].</p>		<p>There are up to 15 recipes programmed in the control. Touch [▲] or [▼] to scroll through the list. Touch and highlight the recipe name in the selection window. Touch [VIEW].</p>
<p>Touch [X] to return to the Main Recipe screen.</p>		<p>The summary screen for the recipe selected is displayed. The screen displays the Preheat temperature setting, the Cook time and temperature for each cook segment and the Hold temperature. Any stage labeled "off" is disabled in the recipe.</p>
Cooking a Recipe		
<p>Touch and highlight the desired recipe. Touch [COOK].</p>		<p>There are up to 15 recipes programmed in the control. Touch [▲] or [▼] to scroll through the list. Touch and highlight the recipe name in the selection window. Touch [COOK].</p>
<p>Touch [PREHEAT] or [COOK].</p>		<p>Touch [PREHEAT] to heat the oven to the programmed preheat temperature. Touch [COOK] to begin the first cook segment without preheating the oven. It is recommended to always preheat the oven before starting to cook. Touch [T] at any point to view the actual oven cavity temperature. The temperature will be displayed for 10 seconds.</p>
<p>Preheating screen is displayed. To exit the cook recipe touch and hold [X] until the control chirps twice.</p>		<p>The preheating screen for the recipe is displayed. The programmed preheat temperature is displayed at the bottom of the screen. Touch [T] at any point to view the actual oven cavity temperature. The oven cavity temperature will be displayed for 10 seconds.</p>

Cooking a Recipe (continued)		
<p>LOAD OVEN screen is displayed. To exit the cook recipe touch and hold [X] until the control chirps twice.</p>		<p>When the oven reaches the programmed preheat temperature the LOAD OVEN screen is displayed. The control will emit an audible alarm for 5 seconds and the screen background will alternate between green and blue until the oven is loaded or the large button is touched.</p>
<p>Load the oven. Touch the large [START COOK] button to begin cooking.</p>		<p>After loading the oven (opening and closing the door once) the START COOK screen is displayed. The screen background will alternate between green and blue until the large button is touched. To beginning cooking, close the oven door and touch the large [START COOK] button.</p>
<p>Main cooking screen is displayed. To exit the cook recipe touch and hold [X] until the control chirps twice.</p>		<p>The main cooking screen is displayed while the cook is in progress. The Time displayed is the time remaining in the active cook segment. The progress bar shows the progress through the sum of all of the programmed cook segment times. The Temperature display is the programmed temperature for the active cook segment. Touch [T] at any point to view the actual oven cavity temperature. The oven cavity temperature will be displayed for 10 seconds. Touching [Ex] will add the preset extra time (typically 5 minutes) to the active cook segment.</p>
<p>End of Cooking</p>	<p>End of Cooking without Hold On completion of the last cook segment the [BEEP] button will flash red and the control will emit a continuous audible alarm. To cancel the audible alarm, touch [BEEP]. If additional cooking is required, touch [Ex]. This will cook for the preset extra time (typically 5 minutes) at the temperature programmed for the last cook segment. If no additional cooking is required, remove all cooked product from the oven then touch and hold [X] until the control chirps and returns to the main recipe screen.</p>	<p>End of Cooking with Hold On completion of the last cook segment the [BEEP] button will flash red and the control will emit a continuous audible alarm. The control will automatically go into Hold and maintain the oven cavity at the programmed temperature. To cancel the audible alarm, touch [BEEP]. The control will stay in Hold. Measure the internal temperature of the cooked product. If additional cooking is required, touch [Ex]. This will cook for the preset extra time (typically 5 minutes) at the temperature programmed for the last cook segment. Once all cooked product has been removed from the oven, touch and hold [X] until the control chirps and returns to the main recipe screen.</p>

Configuring the CTS Controller for use in the VGG Oven

The Controller configuration must be verified as described below after installing a CP0065 Controller in the VGG oven.

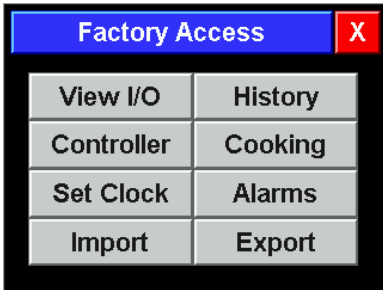
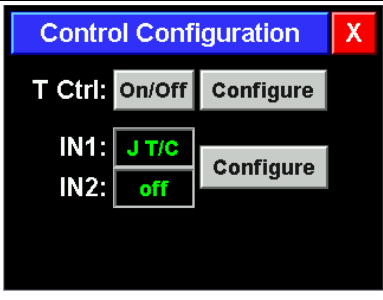
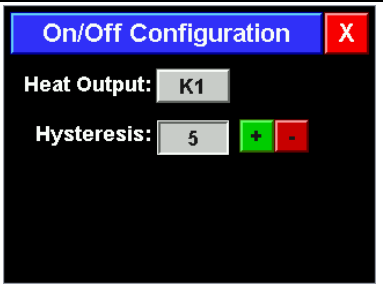
<p>Touch and hold the lower right portion of the screen until the control chirps twice.</p>		<p>The area on the control screen is black. The red graphic in this diagrams indicates the area to touch and hold.</p>
<p>Enter your access code. Touch [X] to exit and return to Main Recipe screen. [Delete] clears the last character. [Clear] clears all characters.</p>		<p>The configuration access code is 9999.</p>
<p>Factory access screen is displayed. Touch [X] to exit and return to Main Recipe screen.</p>		<p>Touch the [Controller] button and follow the configuration instructions below.</p>
<p>Touch [X] to exit and return to Factory Access screen.</p>		<p>Touch the T Ctrl: [Configure] button.</p>
<p>Touch [X] twice to return to the Factory Access screen.</p>		<p>Touch the Hysteresis: [+] and [-] buttons to set the hysteresis to 5. Touch [X] twice to return to the Factory Access screen.</p>

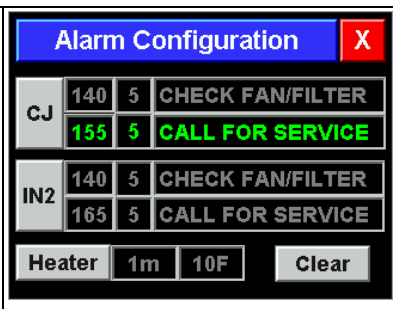
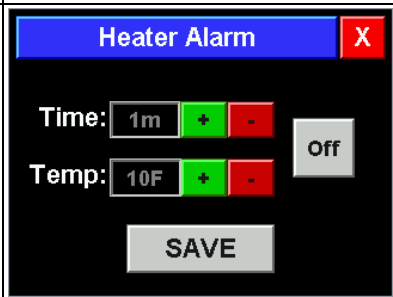
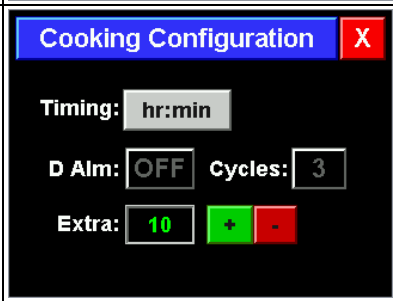
<p>Alarm Configuration screen is displayed.</p>		<p>Touch the [Alarms] button on the Factory Access Screen.</p> <p>Touch the [Heater] button at the bottom of the Alarm Configuration screen.</p>
<p>Heater Alarm screen is displayed.</p>		<p>Use the [+] and [-] buttons to set Time: to 3m and Temp: to 50F.</p> <p>Touch [X] twice to return to the Factory Access screen.</p>
<p>Cooking Configuration screen is displayed.</p>		<p>Touch the [Cooking] button on the Factory Access Screen.</p> <p>Use the [+] and [-] buttons to Extra: to 5.</p> <p>Touch [X] three times to return to the main Cook screen. The Controller is now properly configured.</p>

Controller Errors, Warnings and Events

Errors

These events cause the controller to halt operation and display the fault in the System Error screen shown at right. The faults are not recoverable. The System Error screen does allow the controller to be rebooted in an attempt rectify the fault but this may not work.

An additional line of text will be displayed above "CALL FOR SERVICE" to provide more detailed information about the type of error. In addition, an error event will be recorded in the controller's history.

Here is a list of errors with their descriptive text in the System Error and History screens:



System Error text	History text	Error Description
TEMPERATURE PROBE ERROR	Probe Error	The temperature probe reading is out of range indicating a probe failure.
TOUCHSCREEN ERROR	Tch Scr Error	The touch screen is cracked or contaminated.
ERROR SAVING TO MEMORY STORAGE	NVM-W Error	AN error was detected writing to the controller's internal memory.
ERROR READING FROM MEMORY STORAGE	NVM-R Error	AN error was detected reading from the controller's internal memory.
GP FAULT:nnnnnn AT ADDR:aaaaaa	GP Fault	A general protection fault has occurred when reading or writing to an invalid memory address.

Warnings and Alarms

The CTS Rotisserie Oven Controller has multiple alarms to warn the operator in the case of certain problems within the oven. These alarms are informational only and will not stop the controller from functioning. A warning message formatted as shown at the right will flash on the screen every 30 seconds.



The alarms can be cleared using in [Clr Alarm] on the Supervisor Access screen. Refer to the *Configuring the CTS Oven Controller* section of this manual. If the alarms conditions are still present after clearing the alarms, the alarm will reappear.

Here is a list of the Warning messages and a description of the potential cause

**OVEN NOT HEATING
CALL FOR SERVICE**

If the oven does not begin to heat when Preheat is initiated this warning message is displayed. At this point the gas spark ignition controller has locked out. Turn the power to the oven off, then back on to reset the gas spark ignition controller.

If the warning message is displayed again after the gas spark ignition controller has been reset call the authorized BKI service agency to service the oven.

**CTRL TEMP WARNING
CHECK COOLING FAN**

This warning message indicates the temperature in the oven's control compartment has risen to a temperature that would indicate a problem with the cooling fan on the back of the control side of the oven. Verify that the fan's grill is not blocked and that the fan is operating when the oven is on.

If the fan is not operating, call the authorized BKI service agency to service the oven.

**CTRL TEMP WARNING
CALL FOR SERVICE**

This message is displayed when the temperature in the oven's control compartment rises to a temperature that will harm the oven's components. Use of the oven should be discontinued at the completion of the current cooking recipe. Call the authorized BKI service agency to service the oven.

Events

Here is a list of controller system events which cause an entry in the History log:

Factory Rst	Factory Reset is performed as the controller is being tested at the factory. This resets the recipes and controller configuration to defaults and performs a touchscreen calibration.
Tch Scr Cal	Touch screen calibration during the factory reset or performed by the user.
Config Chg	This indicates that the controller configuration has been changed which includes Supervisory or Factory level changes but not PID configuration changes.
PID Cfg Chg	The PID configuration was changed.
Access Err	An invalid password was entered.
Access Chg	The Supervisor password was changed.
Recipe Imp	The recipes were imported from a USB flash drive.
Recipe Exp	The recipes were exported to a USB flash drive.
Config Import	The controller configuration was imported from a USB flash drive.
Config Export	The controller configuration was exported to a USB flash drive.
USB Error	The controller was unable to create or find the proper file on the flash drive.
CJ Warning	The lower level cold junction time and temperature alarm was exceeded.
CJ Alarm	The higher level cold junction time and temperature alarm was exceeded.
IN2 Warning	The lower level IN2 probe time and temperature alarm was exceeded.
IN2 Alarm	The higher level IN2 probe time and temperature alarm was exceeded.
Heat Alarm	The oven temperature did not rise fast enough when the preheat was started.
Alarm Chg	The warning / alarming configuration was changed.

Accessory Use

Trussing Chickens

It is recommended that whole chickens be trussed before cooking. Trussing holds the wings and legs of the chicken tightly against the body. This improves the visual appeal of the chickens while they are cooking. In addition trussing keeps the chicken moist by retaining more of the natural juices and helps prevent the wing tips from burning.

Using 6 ½" – 7" elastic ties, follow these simple steps to truss the chickens.



1. Fold wing tips back under the chicken.



2. With the back of the chicken up slip the tie under the wings and pull back.



3. Pull and twist the tie over the back of the chicken to form an "X". Make sure wing tips are under tie.



4. Turn the chicken over and pull the tie over the ends of the legs.

V-Spits

Up to four (4) whole chickens can be placed on a VGG-8 V-spit and up to four (3) whole chickens can be placed on a VGG-5 V-spit. Insert the tapered end of the V-spit under the legs and through the cavity of the trussed chicken as shown below. Orient the spit with the “V” toward the breast side of the chicken. The legs and thighs of the chicken should be on the same side of the V-spit as the breast.



Make sure the chickens are evenly spaced on the v-spit. Do not place more than the recommended number of chickens on a V-spit. Chickens that are pushed tightly together on the V-spit will not brown properly during cooking leaving “blonde” areas where the two chickens were touching.

The VGG-8 will hold up to 8 V-spits and the VGG-5 will hold up to 5 V-spits. When loading fewer V-spits, space the V-spits as evenly as possible on the rotors. Balancing the load on the rotors will extend the life of the rotor drive system. When loading only 2 or 3 spits **DO NOT** place them in adjacent mounting locations on the rotors.

Standard Meat forks

The standard meat forks are ideal for chicken and poultry. Use the following procedure to prepare the bird for loading in the oven.

1. Fold wings to back, place on back with cavity away from you.
2. Run pointed ends of meat fork through sides of chicken under wings and through thighs (breast up and legs down). Ensure that legs of adjacent birds **DO NOT PRESS TIGHTLY TOGETHER**, this will cause the area of contact to be under-cooked!
3. Load the meat-forks by holding the meat-fork with the handle to the right-hand side, facing up.
4. Open the oven door.
5. Press Rotor Switch to rotate rotor to open position if required.
6. Place the pointed ends of the meat-fork into the left-hand disc holes.
7. From the control side, push the meat-fork into the disc to allow the right-hand (handle end) pins locate into the right-hand disc.
8. Be sure to adjust the meat-fork position so that the handle end locates firmly in the spit groove.

Baskets

Baskets can be used for large chickens or other meats. After loading with product, simply locate pins in the holes on the discs.

Installation

⚠ WARNING

Serious injury, equipment damage or death could result if attempting to install this oven yourself. Ensure that an authorized **BKI** service agent install the oven.

Unpacking and Handling

It is the owners' responsibility to file all freight claims with the delivering truck line. Inspect all cartons and crates for damage as soon as they arrive. If damage to cartons or crates is found, or if a shortage is found, note this on the bill of lading (all copies) prior to signing.

If damage is found when the equipment is opened, immediately call the delivering truck line and follow up the call with a written report indicating concealed damage to your shipment. Ask for an immediate inspection of your concealed damage item. Packaging material **MUST** be retained to show the inspector from the truck line.

Remove all packing from the interior and exterior of the oven.

Location and Clearance

The oven must be mounted on a level surface capable of supporting the fully loaded oven. Refer to Chart 1 for oven weight.

Adequate clearance must be provided around the oven for safety, proper operation and ventilation. Refer to Chart 1 for required minimum clearances. Note that these are minimum clearances. If the oven is to be permanently mounted near other immovable objects additional clearance must be provided for connection and service of the oven on both sides.

All ventilation slots must be kept free from obstruction.

Extraction

Extraction is not a specific requirement for this type of appliance. Certain conditions, e.g./ installation in a confined space, temperature controlled environment, continuous use or high volume production cooking may require the need for extra ventilation or extraction. Consult your local ventilation/extraction air conditioning company or contact the technical services department at BKI.

Wiring

⚠ WARNING

Electrocution, equipment failure or property damage could result if an unlicensed electrician performs the electrical installation. Ensure that a licensed electrician perform the electrical installation in accordance with applicable local and national codes.

General Guidelines

- In the absence of local codes refer to the latest edition of one of the following:
 - National Electrical Code, ANSI/NFPA 70-20XX (USA) which can be obtained from:

The National Fire Protection Association
Batterymarch Park
Quincy, MA 02269

- I.E.E. Wiring Regulations (Europe)
- Verify that the power supply conforms to the electrical rating listed on the oven data plate.
- Ensure that the appliance is grounded (earthed).

Chart 1. Location and Clearance

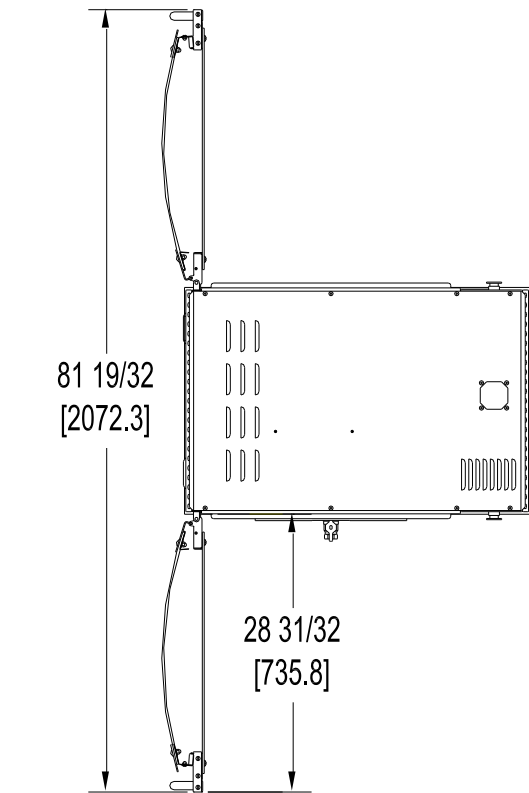

Electrical Specifications (North America)

1Ph + Gnd, 60Hz

Volts	Amps	KW	Breaker
208	29.3	6.1	40
220	23.5	5.2	30
240	27.8	6.7	40

Electrical Specifications (North America)

3Ph + Gnd, 60Hz

Volts	Amps	KW	Breaker
208	17.2	6.1	25
220	13.8	5.2	20
240	16.3	6.7	25

Electrical Specifications (Europe)

230/400 Volts, 3Ph + Gnd + E, 50Hz

	Amps	Watts	Breaker
L1	9.3	2182	10
L2	9.3	2130	
L3	9.2	2120	

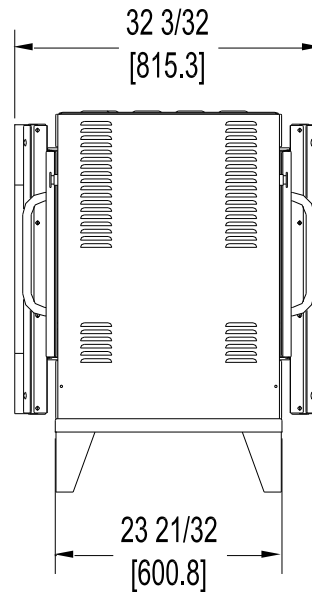
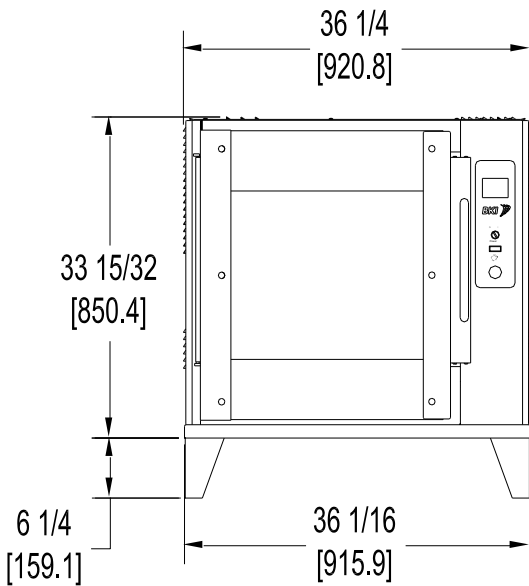

Model	Height	Shipping Weight	Minimum Clearance	
			Combustible Surface	Non-Combustible Surface
VGG-5	1009.5 mm	195 KG	152.5 mm	152.5 mm
	39.7 in.	430 lb.	6 in.	6 in.

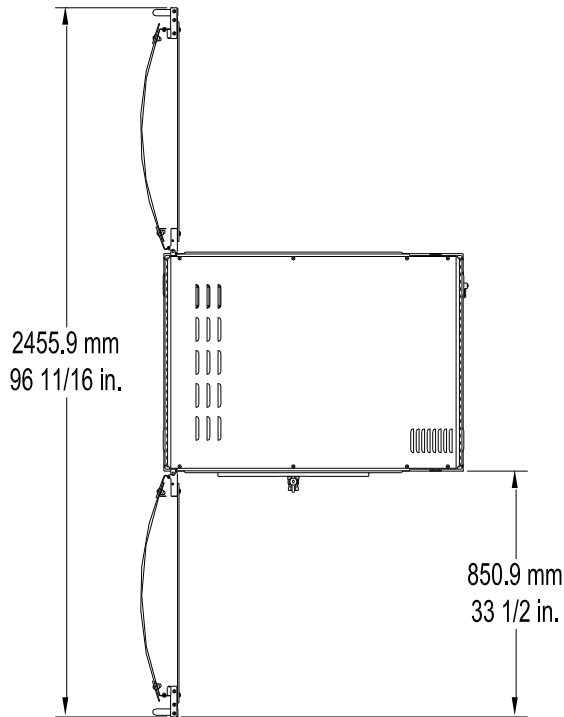

Electrical Specifications (North America)

3Ph + Gnd, 60Hz

Volts	Amps	KW	Breaker
208	29.7*	10.6*	40*
220	26.4*	9.9*	35*
240	28.7*	11.8*	40*

* Ratings per oven cavity. VGG-16 requires a separate power supply for each oven cavity.

Electrical Specifications (Europe)

230/400 Volts, 3Ph + Gnd + E, 50Hz

Model	Amps	KW	Breaker
VGG-8	16.3	10.9	25
VGG-16	32.2	21.8	32

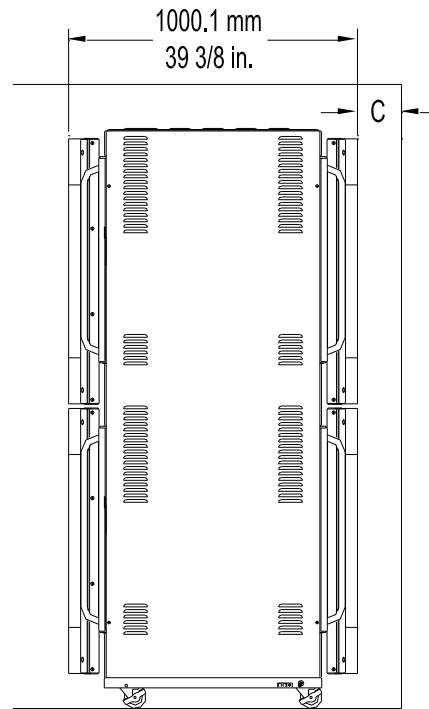
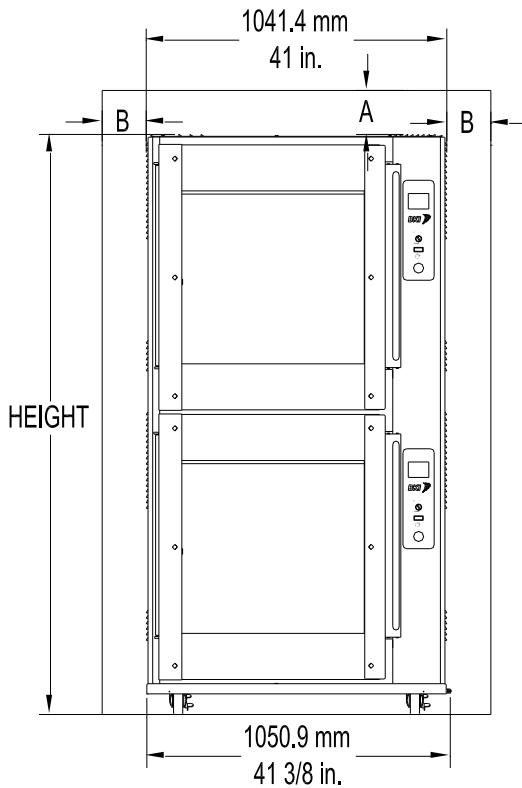

Model	Height	Shipping Weight	Minimum Clearance					
			Combustible Surface			Non-Combustible Surface		
			A	B	C	A	B	C
VGG-8	1003.3 mm	259 KG	152.5 mm	152.5 mm	152.5 mm	51.0 mm	51.0 mm	51.0 mm
	39.5 in.	570 lb.	6 in.	6 in.	6 in.	2 in.	2 in.	2 in.
VGG-16	2008.2 mm	453 KG	152.5 mm	152.5 mm	152.5 mm	51.0 mm	51.0 mm	51.0 mm
	79 1/16 in.	1000 lb.	6 in.	6 in.	6 in.	2 in.	2 in.	2 in.

Guidelines for European Appliances

Note: - A method of disconnection from the main supply having a contact separation of least 3mm in all poles must be incorporated in the fixed wiring.

- It is recommended that an **R.C.D.** with a 30ma trip and contact rating to suit the appliance current be installed adjacent to the appliance.
- Type C/ 3 circuit breakers or appropriate rated fuses are recommended for installation at the supply end.

Note: - surge currents are present when this appliance is switched on from cold.

- Industrial plugs and sockets must comply with BS 4343/EN60309 (IEC309.2/CEE17).

Supply Cable Connection

- It is recommended that the power supply cable shall be an oil resistance sheathed flexible cable to BS 6007 (code designation HO7 RN-F).
- It is required that the power supply cable connection to the appliance terminal block, the earth conductor is to be made at least 50mm longer than the length of the live (L) and neutral (N) conductors so that if the supply cable is strained the earth conductor is the last to become disconnected.
- To gain access to the control panel and mains block connection, remove the 4-side panel securing screws on the drive side of the oven.
- The mains block is sited toward the bottom right hand side of the control box. Cable entry is provided through the base of the oven.
- Refer to the mains wiring diagram for correct connection.

Operating

Please read the operating instructions thoroughly and ensure all packaging has been removed before switching main power 'On'.

IMPORTANT: Ensure that whoever is operating this appliance is fully conversant with its working and is made aware of the dangers of incorrect operation.

Safety Cut-Out

For added safety all VGG ovens have a built in thermal cut-out to protect against over-heating through component failure or incorrect use. If for any reason the thermal cut-out operates, the oven will automatically shut down and should be switched 'Off', disconnected from the mains and allowed to cool.

NOTE: - The thermal cut-out will not re-set automatically.

The oven must not be re-used until a qualified electrician or BKI service agent has checked it.

Maintenance



Failure to comply with the maintenance below could result in a serious accident or equipment damage.



Failure to remove power from this unit before performing maintenance may cause severe electrical shock. This unit may have more than one disconnect switch.

Scheduled Maintenance

Use the following table to help manage scheduled maintenance activities.

Frequency	Performed By	Part	Activity
Daily	User	Entire Oven	Perform oven-cleaning procedure.
6 months	User	Fan Blade	Remove and replace.

Oven Cleaning (Daily)

Cleaning is not only necessary for sanitary reasons, but will increase sales appeal and maximize operating efficiency.



Failure to remove power from this unit may cause severe electrical shock. This unit may have more than one disconnect switch.



Always wear appropriate personal protection equipment (goggles, rubber glove & long sleeved garments) when cleaning the oven to guard against possible injury.

Using abrasive cleaners will damage the cabinet finish. Use only a mild soap and water solution or approved cleaner.

DO NOT USE OVEN CLEANER on this machine. Caustic cleaners will cause damage to the machine.

NEVER USE A WATER HOSE OR A STEAM CLEANER TO WASH THIS UNIT. Excess water can get into the interior of the cabinet and cause damage.

BKI Approved Cleaning Solutions

ECOLAB Greasestrip Plus
 Proctor & Gamble DCT Oven Cleaner
 J. Wilson Marketing Combi Brite Cleaner

1. Turn the Main Power Switch off and disconnect from the Main Power Isolator (Circuit Breaker).
2. Allow oven to cool below **50° C (120° F)**.
3. Empty the grease drawer using the drain valve or fat pump.
4. Remove all food products from the unit.
5. Remove V-spits, meat forks, hanging baskets and drip trays from the unit and place them in a large sink to soak in hot cleaning solution. Clean the components with warm water, a sponge and **BKI Cleaner**. Wipe dry with a clean cloth.

6. Remove the Rotor System as described below:
 - a. Lift the washer from the groove and slide down the shaft.
 - b. Slide each rotor cup down the shaft.
 - c. Remove the inner shaft.

NOTE: The welded bead in the center of shaft denotes the shaft removal direction.
 - d. Remove rotors.
7. Place the Rotor System components in a large sink to soak in hot cleaning solution. Clean the components with warm water, a sponge and **BKI** Cleaner. Wipe dry with a clean cloth.
8. Remove the Fan Cover as described below:
 - a. Grasp the Fan Cover Hand Grip with both hands. Lift up on the Fan Cover then pull out approximately 1/2" [12 mm].
 - b. Lower the front of the Fan Cover until the Switch Actuator clears slot in the top of the oven cavity (see detail view).
 - c. Support the back of the Fan Cover with one hand and pull the Fan Cover out of the support pins in the oven cavity sides with the other hand.
 - d. Remove the Fan Guard from the Circulation Bottom by pulling the Fan Guard handle out then up.

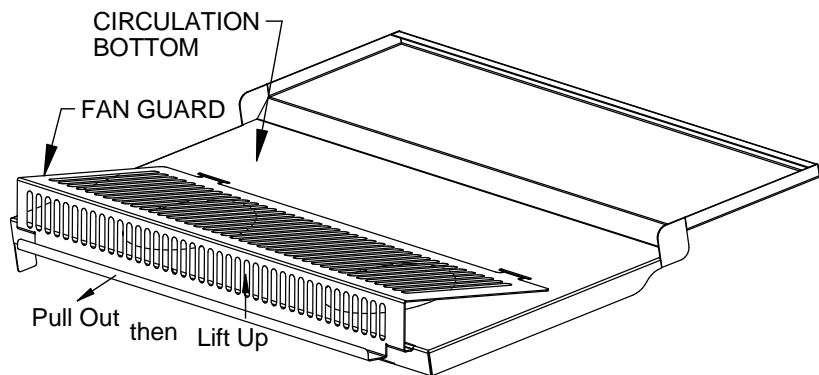
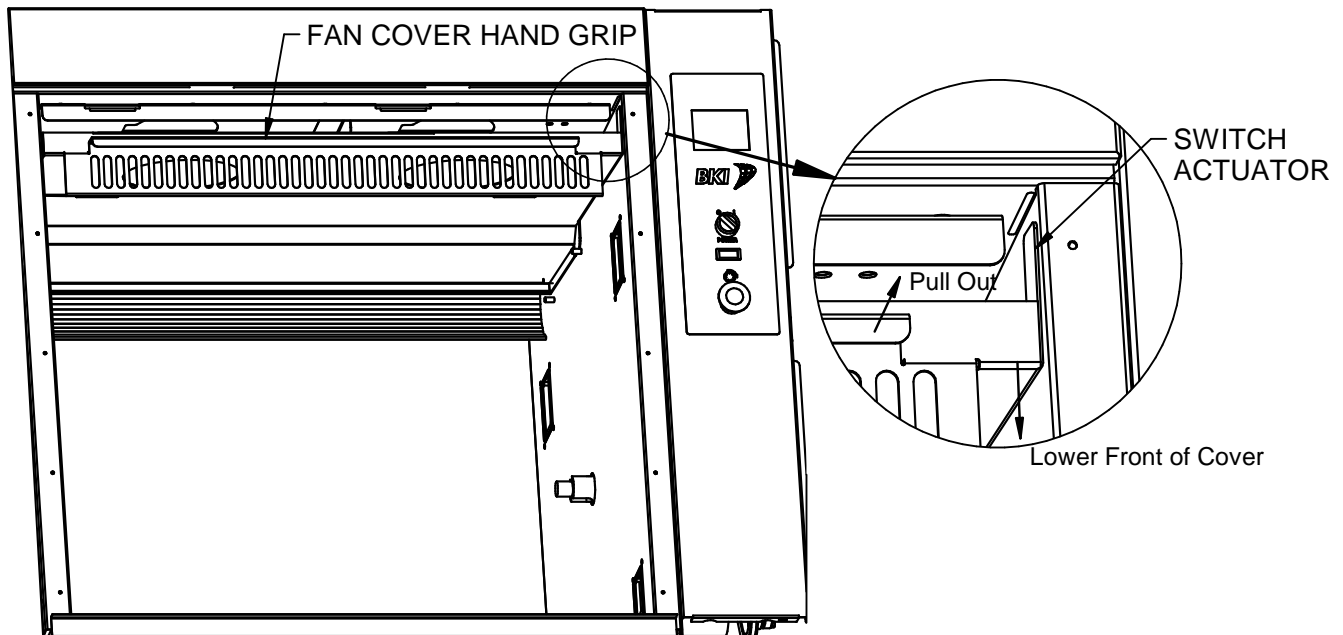

9. Place the Fan Guard and Circulation Bottom in a large sink to soak in hot cleaning solution. Clean the components with warm water, a sponge and **BKI** Cleaner. Wipe dry with a clean cloth.
10. Carefully clean the fan blades using a scrub brush and hot cleaning solution. Do not bend or disfigure the fan blades.
11. Clean the top of oven. Carefully clean around fan and surrounding areas.
12. Replace the Fan Guard onto the Circulation Bottom. Then install this Fan Cover assembly back into the oven cavity.
13. Clean grease drawer and tray area with hot soapy water.
14. Replace the grease drawer.
15. Clean the outside and inside of the rotisserie oven with warm water, a sponge and an approved cleaner which is authorized for use on food surface areas.
16. Reassemble the rotor system in the oven.

Troubleshooting

Problem	Cause	Possible Solution
Unit will not turn on. Main Power Isolator Light is not lit.	Unit power plug disconnected (where applicable).	Plug unit into mating receptacle.
	Problem with building power supply	Check circuit breaker at building power panel. If problem persists, contact BKI service agent for corrective action.
Unit will not turn on. Main Power Isolator Light is lit.	Blown Fuse	Contact BKI service agent for corrective action.
	Safety cut out thermostat tripped or defective.	Contact BKI service agent for corrective action.
	Defective contactor.	Contact BKI service agent for corrective action.
Rotor not rotating.	Door not completely closed.	Check that both doors are completely closed
	Defective door switch.	Contact BKI service agent for corrective action.
	Blown Fuse	Contact BKI service agent for corrective action.
	Defective contactor.	Contact BKI service agent for corrective action.
	Defective motor or capacitor.	Contact BKI service agent for corrective action.
Rotor will not rotate while depressing Rotor switch with door open but operates with doors closed.	Defective rotor switch.	Contact BKI service agent for corrective action.
Oven does not heat at all.	Improper program settings.	Check program settings.
	Improper parameter settings.	Contact BKI service agent for corrective action.
	Fan cover & circulation bottom not installed or improperly installed.	Check that components are properly installed.
	Fan cover switch defective.	Contact BKI service agent for corrective action.
	Defective controller or contactor.	Contact BKI service agent for corrective action.
	Heating elements not functioning.	Contact BKI service agent for corrective action.
Oven heats up slowly	Improper line voltage.	Contact BKI service agent for corrective action.

Problem	Cause	Possible Solution
	Defective blower fan motor.	Contact BKI service agent for corrective action.
	Defective heating element.	Contact BKI service agent for corrective action.
Control displays "999" under the temperature display.	Temperature probe connection loose or defective probe.	Contact BKI service agent for corrective action.
Cavity lights do not illuminate when unit is on.	Faulty power supply.	Contact BKI service agent for corrective action.
Individual cavity lamp does not illuminate.	Defective lamp.	Contact BKI service agent for corrective action.

Accessories

Description	Part No.	Item
MEAT BASKET w/ 4 GOOSERS, VGG-8 (Not available for VGG-5)	MB0037	1
MEAT BASKET, VGG-5 MEAT BASKET, VGG-8	MB0040 MB0038	2
MEAT FORK, VGG-5 MEAT FORK, VGG-8	MF0044 MF0032	3
VEE SPIT, VGG-5 VEE SPIT, VGG-8	MF0045 MF0038	4
BKI RUBBER GLOVE	G0089	5

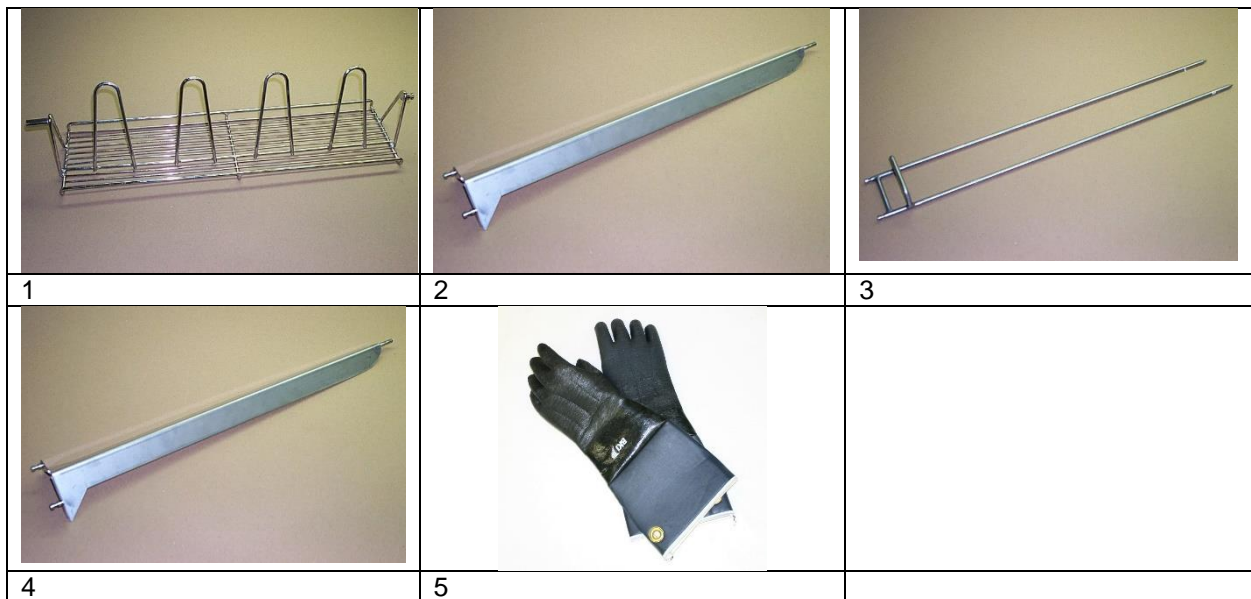

Wiring Diagrams

Refer to the table below to find the wiring diagram associated with your unit.

Wiring Diagram	Part #	Figure #
VGG-8 10.2kW, 208V-240V, 3 Phase Delta	SB55090000	Figure 11
VGG-8 12.0kW, 208V-240V, 3 Phase Delta	SB55090100	Figure 12
VGG-8 10.2kW, 230/400V, 3 Phase Wye	SB55090200	Figure 13
VGG-8 12.0kW, 230/400V, 3 Phase Wye	SB55090300	Figure 14
VGG-5 208-240V, 3 Phase Delta	SB55092000	Figure 15
VGG-5 230/400V, 3 Phase Wye	SB55092100	Figure 16

Figure 11. VGG-8 10.2kW, 208V-240V, 3 Phase (SB5509000)

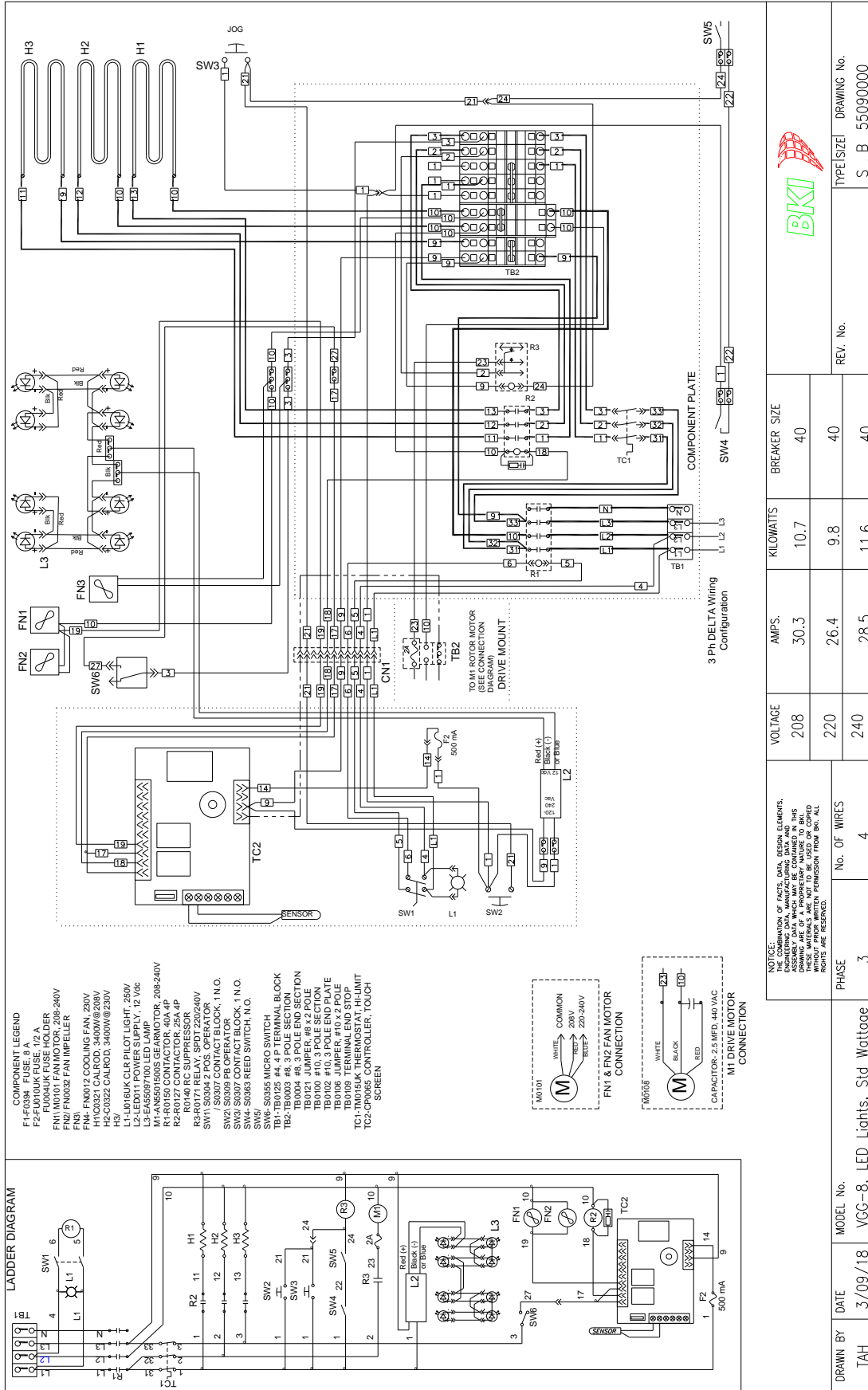

REV. No.	TYPE/SIZE	DRAWING No.
40	S	B 55090000

KILOWATTS	BREAKER SIZE
10.7	40

AMPS.	VOLTAGE
30.3	208

AMPS.	VOLTAGE
26.4	220

AMPS.	VOLTAGE
28.5	240

PHASE	No. OF WIRES
3	4

MODEL No.	DATE
VGG-8, LED Lights, Std Wattage	3/09/18

DRAWN BY	TAH
----------	-----

Figure 12. VGG-8 12.0kW, 208V-240V, 3 Phase (SB55090100)

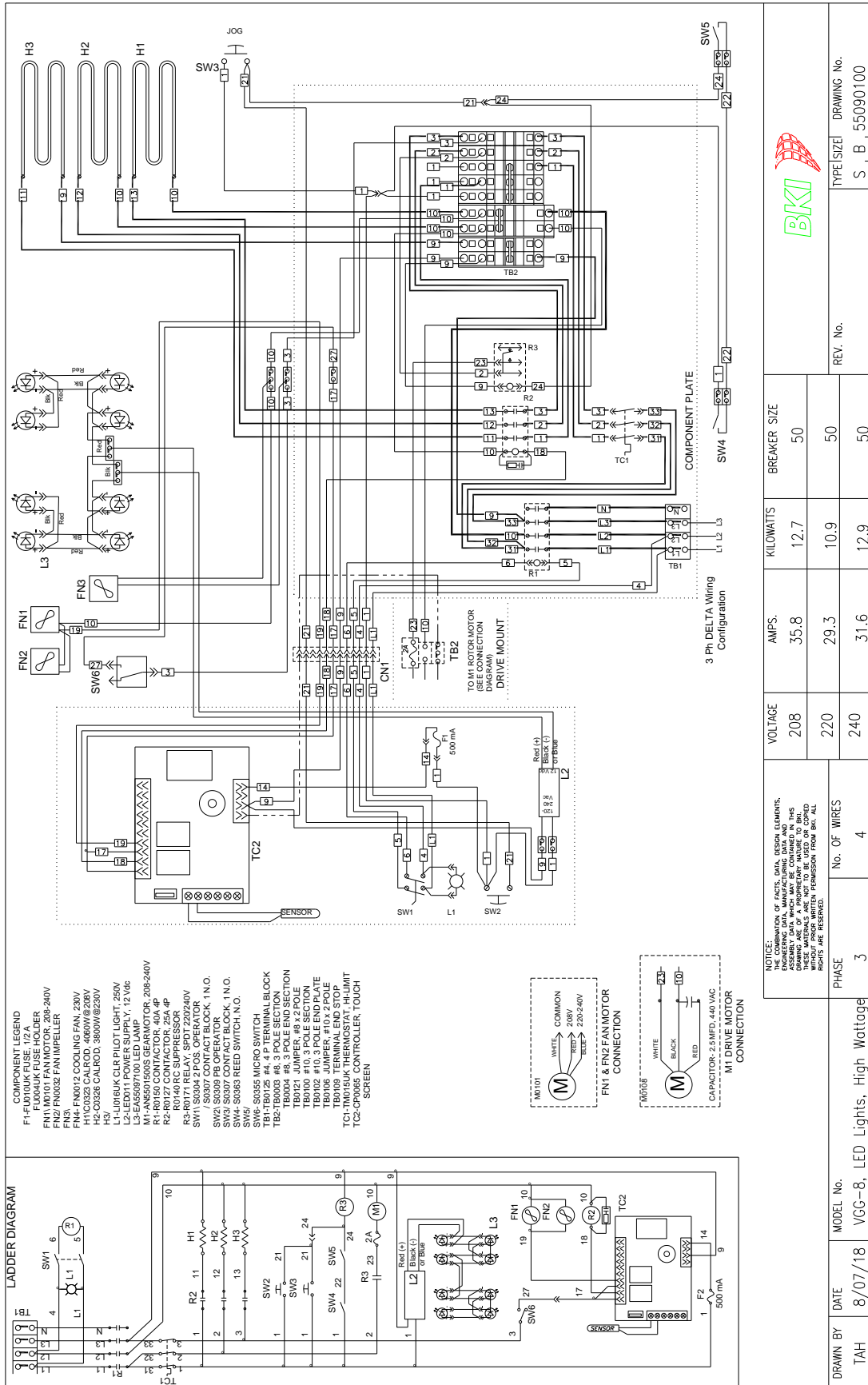

DRAWN BY TAH	DATE 8/07/18	MODEL No. VGG-8, LED Lights, High Wattage	PHASE	3	No. OF WIRES	4	VOLTAGE	208	KILOWATTS	12.7	BREAKER SIZE	50	REV. No.	50	TYPE/SIZE	S B	DRAWING No. 55090100
			220	29.3	50												
			240	31.6	50												

Figure 13. VGG-8 10.2kW, 230/400, 50Hz, 3 Phase (SB55090200)

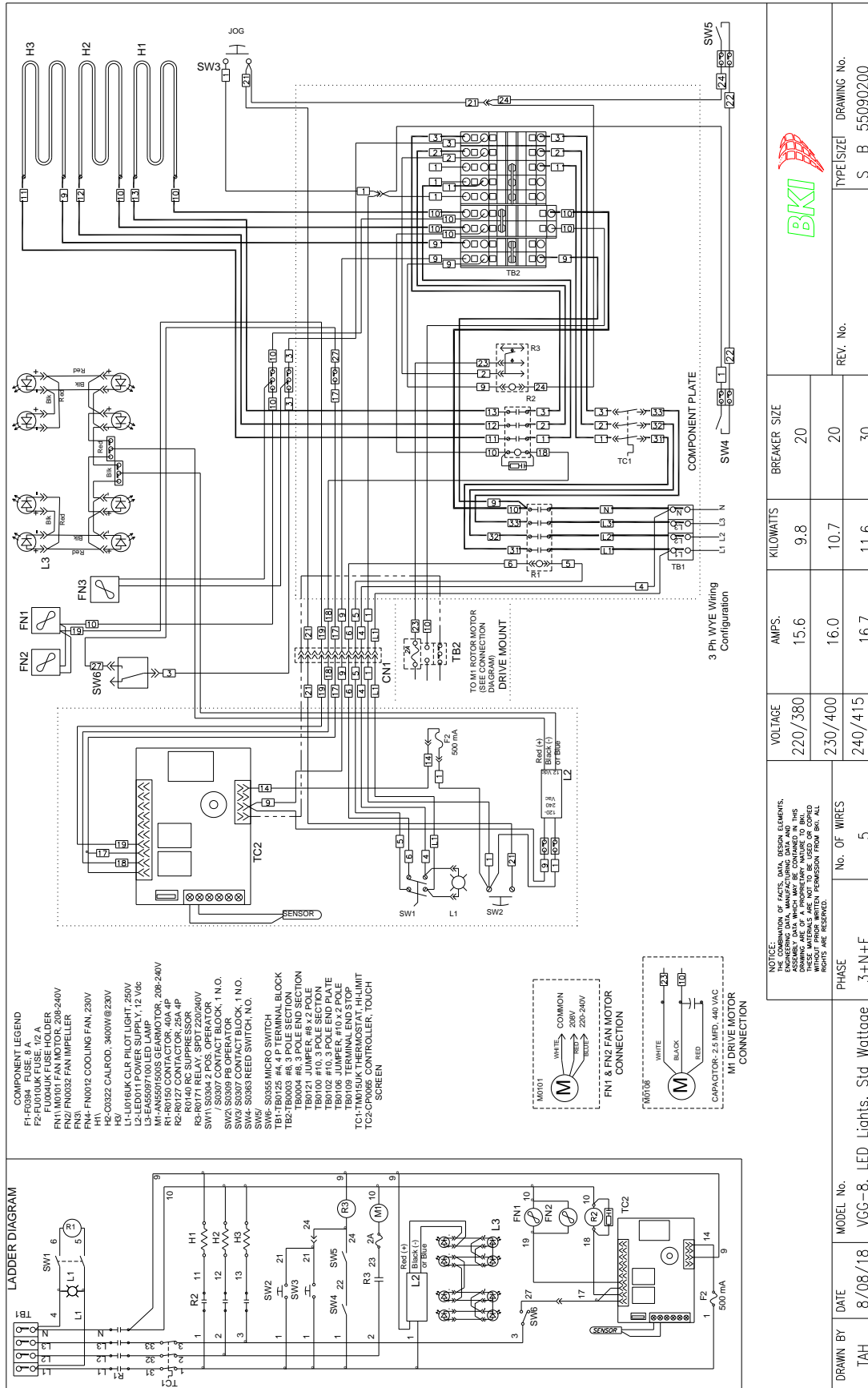

Figure 15. VGG-5, 208-240V, 3 Phase (SB55092000)

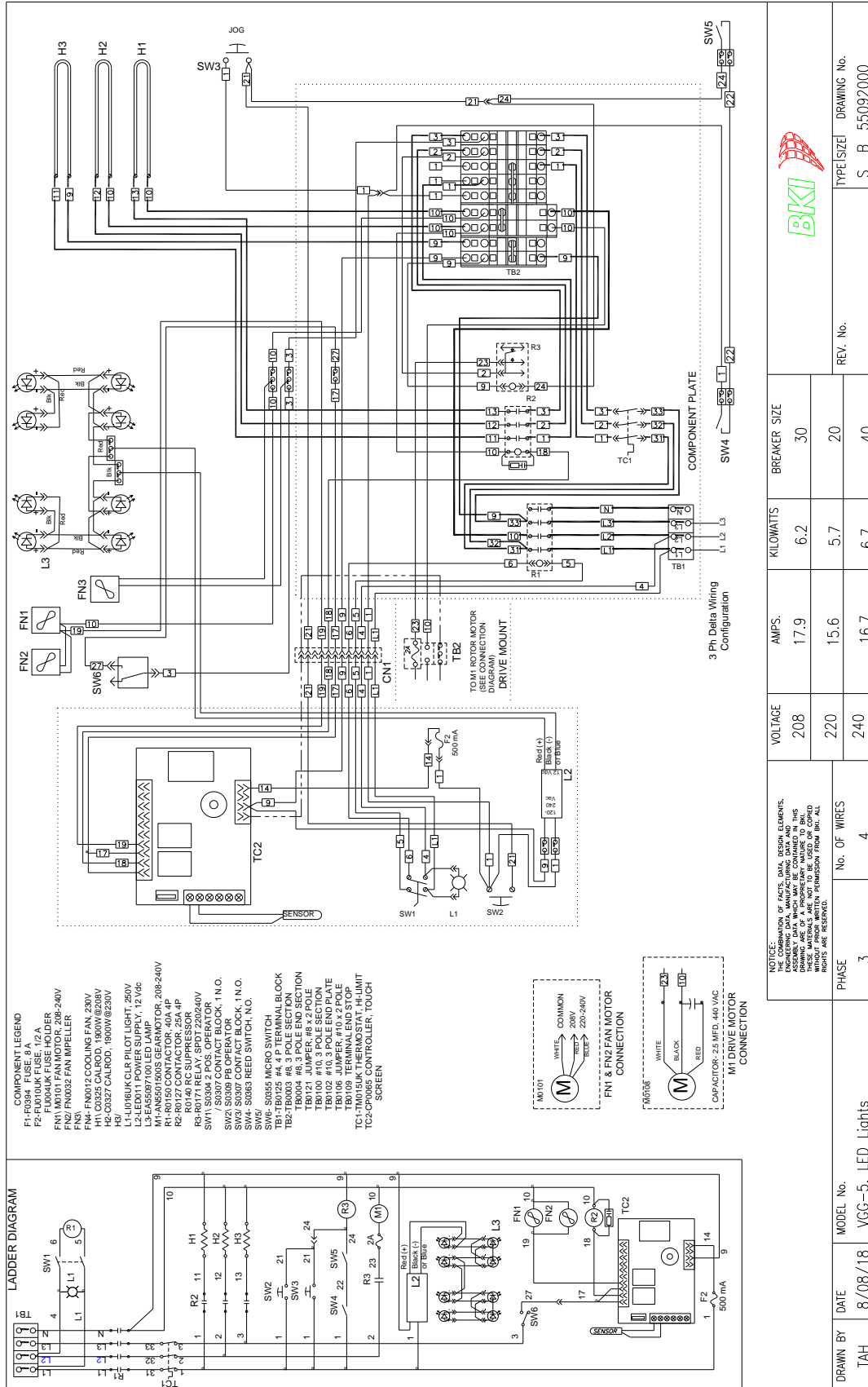
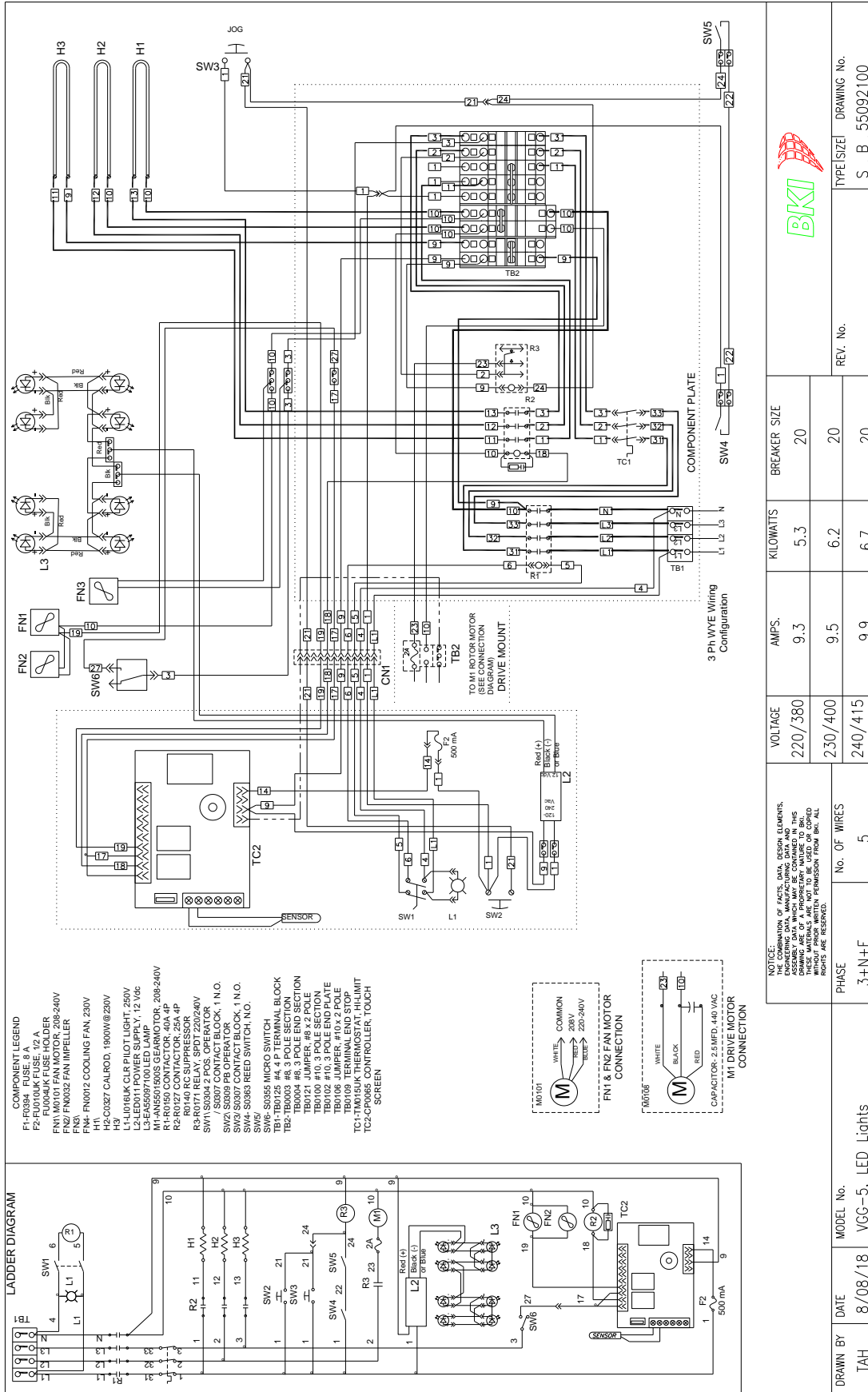

Figure 16. VGG-5, 230/400V, 3 Phase (SB55092100)



NOTES



2812 Grandview Drive, Simpsonville, S.C. 29680, USA
<http://www.bkideas.com>

Made and printed in the U.S.A