

BLODGETT® **BLODGETT**® **BLODGETT**® **BLODGETT**®

BLODGETT® **BLODGETT**® **BLODGETT**®

BLODGETT® **BLODGETT**® **BLODGETT**® **BLODGETT**®

BLODGETT®

XR8-G AND XR8-E
MINI RACK OVEN
INSTALLATION - OPERATION - MAINTENANCE



BLODGETT OVEN COMPANY

www.blodgett.com

42 Allen Martin Drive, Essex Junction, Vermont 05452 USA Telephone: (802) 658-6600 Fax: (802)864-0183

PN 38480 Rev V (1/24)

© 2019 - G.S. Blodgett Corporation

Your Service Agency's Address:

Model

Serial number

Oven installed by

Installation checked by

IMPORTANT

WARNING: Improper installation, adjustment, alternation, service or maintenance can cause property damage, injury or death. Read the installation, operation and maintenance instructions thoroughly before installing or servicing this equipment.

INSTRUCTIONS TO BE FOLLOWED IN THE EVENT THE USER SMELLS GAS MUST BE POSTED IN A PROMINENT LOCATION. This information may be obtained by contacting your local gas supplier.

FOR YOUR SAFETY

Do not store or use gasoline or other flammable vapors or liquids in the vicinity of this or any other appliance.

The information contained in this manual is important for the proper installation, use, and maintenance of this oven. Adherence to these procedures and instructions will result in satisfactory baking results and long, trouble free service. Please read this manual carefully and retain it for future reference.

ERRORS: Descriptive, typographic or pictorial errors are subject to correction. Specifications are subject to change without notice.

TABLE OF CONTENTS

INSTALLATION

| | |
|---|----|
| Oven Description and Specifications | 2 |
| Delivery and Location | 3 |
| Oven Assembly | 4 |
| Ventilation (XR8-G only) | 5 |
| Utility Connections - Standards and Codes | 7 |
| Gas Connection (XR8-G only) | 8 |
| Gas Piping | 8 |
| Pressure Regulation and Testing | 9 |
| Gas Hose Restraint | 10 |
| Plumbing and Electrical Connections | 11 |
| Initial Startup | 12 |

OPERATION

| | |
|--|----|
| Safety Information | 13 |
| Standard Control | 14 |
| MenuSelect™ Control | 16 |
| General Guidelines for Operating Personnel | 20 |

MAINTENANCE

| | |
|---|----|
| Cleaning and Preventative Maintenance | 21 |
| Troubleshooting Guide | 22 |



Installation

Oven Description and Specifications

The Blodgett Mini-Rack oven features a continuously rotating eight pan rack and unique airflow system that moves large amounts of air at low velocity to ensure a consistently even bake. The Blodgett rack slide system allows the operator to quickly adjust slide spacing from 1 to 4 inches in any configuration. In addition, the Mini-Rack oven is capable of producing large volumes of steam for bagels or similar products.

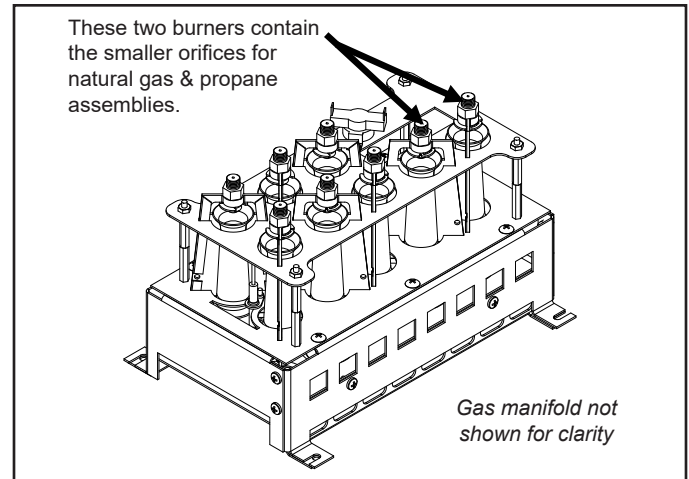

Figure 1

| GAS RATINGS - XR8-G/AB | | | | |
|----------------------------|------------------|------------------------|------------------|------------------------|
| | Natural Gas | | Propane | |
| | US Units | SI Units | US Units | SI Units |
| Heating Value | 1000 BTU/cu. ft. | 37.3 MJ/m ³ | 2550 BTU/cu. ft. | 95.0 MJ/m ³ |
| Specific Gravity (air=1.0) | 0.63 | 0.63 | 1.53 | 1.53 |
| Gas Manifold Pressure | 3.5" W.C. | .87 kPa | 10" W.C. | 2.5 kPa |
| Oven Input | 110,000 BTU/hr | 32 kW 116 MJ/hr | 110,000 BTU/hr | 32 kW 116 MJ/hr |
| Main Burner Orifice Size | | | | |
| Six burners are | 50 MTD* | 1.7 mm | 57 MTD* | 1.0 mm |
| Two burners are | 1/16" | 1.5 mm | 62 MTD* | 0.96 mm |

NOTE: * - Multiple Twist Drill

| PLUMBING SPECIFICATIONS - XR8-G/AB AND XR8-E/AA | |
|---|--|
| WATER | |
| Water pressure | 30 PSI (207 kPa) minimum 75 PSI (517 kPa) maximum |
| Water connection | 3/4" MGHT |
| Flow rate | 27 GPH (102 LPH) |
| DRAINAGE | |
| Drain connection | 3/4" rear drain to air gap drain |

| ELECTRICAL RATINGS- XR8-E/AA | | | | | | | | |
|------------------------------|----|----|-------|-----------------|----|----|------------------|------------------------------|
| VOLTAGE | HZ | KW | PHASE | MAX LOAD (AMPS) | | | CORD SET | MOTOR |
| | | | | L1 | L2 | L2 | | |
| 208 VAC | 60 | 15 | 3 | 44 | 44 | 44 | 15-60P / 4 AWG | 1/4 HP, 115V, 50/60 Hz, 1 ph |
| 240 VAC | 60 | 15 | 3 | 38 | 38 | 38 | 15-60P / 4 AWG | 1/4 HP, 115V, 50/60 Hz, 1 ph |
| 480 VAC | 60 | 15 | 3 | 19 | 19 | 19 | L16-30 P / 8 AWG | 1/4 HP, 115V, 50/60 Hz, 1 ph |

Delivery and Location

DELIVERY AND INSPECTION

All Blodgett ovens are shipped in containers to prevent damage. Upon delivery of your new oven:

- Inspect the shipping container for external damage. Any evidence of damage should be noted on the delivery receipt which must be signed by the driver.
- Uncrate the oven and check for internal damage. Carriers will accept claims for concealed damage if notified within fifteen days of delivery and the shipping container is retained for inspection.

The Blodgett Oven Company cannot assume responsibility for loss or damage suffered in transit. The carrier assumed full responsibility for delivery in good order when the shipment was accepted. We are, however, prepared to assist you if filing a claim is necessary.

OVEN LOCATION

The well planned and proper placement of your oven will result in long term operator convenience and satisfactory performance.

The following clearances must be maintained between the oven and any combustible or non-combustible construction.

- Oven body right side - 0" (0 cm)
- Oven body left side - 0" (0 cm)
- Oven body back - 0" (0 cm)
- Oven top - 12" (30.5 cm)

The following clearances must be available for servicing.

- Oven body sides - 12" (30 cm)
- Oven body back - 12" (30 cm)
- Oven top - 12" (30.5 cm)

NOTE: On gas models, routine servicing can usually be accomplished within the limited movement provided by the gas hose restraint. If the oven needs to be moved further from the wall, the gas must first be turned off and disconnected from the oven before removing the restraint. Reconnect the restraint after the oven has been returned to its normal position.

It is essential that an adequate air supply to the oven be maintained to provide a sufficient flow of combustion and ventilation air.

- Place the oven in an area that is free of drafts.
- Keep the oven area free and clear of all combustibles such as paper, cardboard, and flammable liquids and solvents.
- Do not place the oven on a curb base or seal to a wall. This will restrict the flow of air and prevent proper ventilation. Tripping of the blower motor's thermal overload device is caused by an excessive ambient temperature on the right side of the oven. This condition must be corrected to prevent permanent damage to the oven.
- The location must provide adequate clearance for the air opening into the burners.

Before making any utility connections to this oven, check the rating plate to be sure the oven specifications are compatible with the gas and electrical services supplied for the oven.

1. The rating plate is located on the right side of the oven.
- Do not place strong sources of heat such as open flame ranges, griddles, or charbroilers near the oven. If such an instance exists, it is highly recommended to purchase a heat shield, available from Blodgett.
 - Note that if temperatures are too high, a safety shutdown may occur.
 - Failure to comply may invalidate the oven warranty.



Installation

Oven Assembly

ASSEMBLY TO STAND

1. Center the oven frame on top of the stand so that the oven overhangs at both the front and back.
2. Remove the three screws at the top of the left and right side panels of the oven. Remove the side panels.
3. Align the two bolt holes on each side of the stand with the two threaded holes on each side of the oven.
4. Insert a bolt from the bottom up through each of the two holes and tighten securely.
5. Reinstall the side panels.

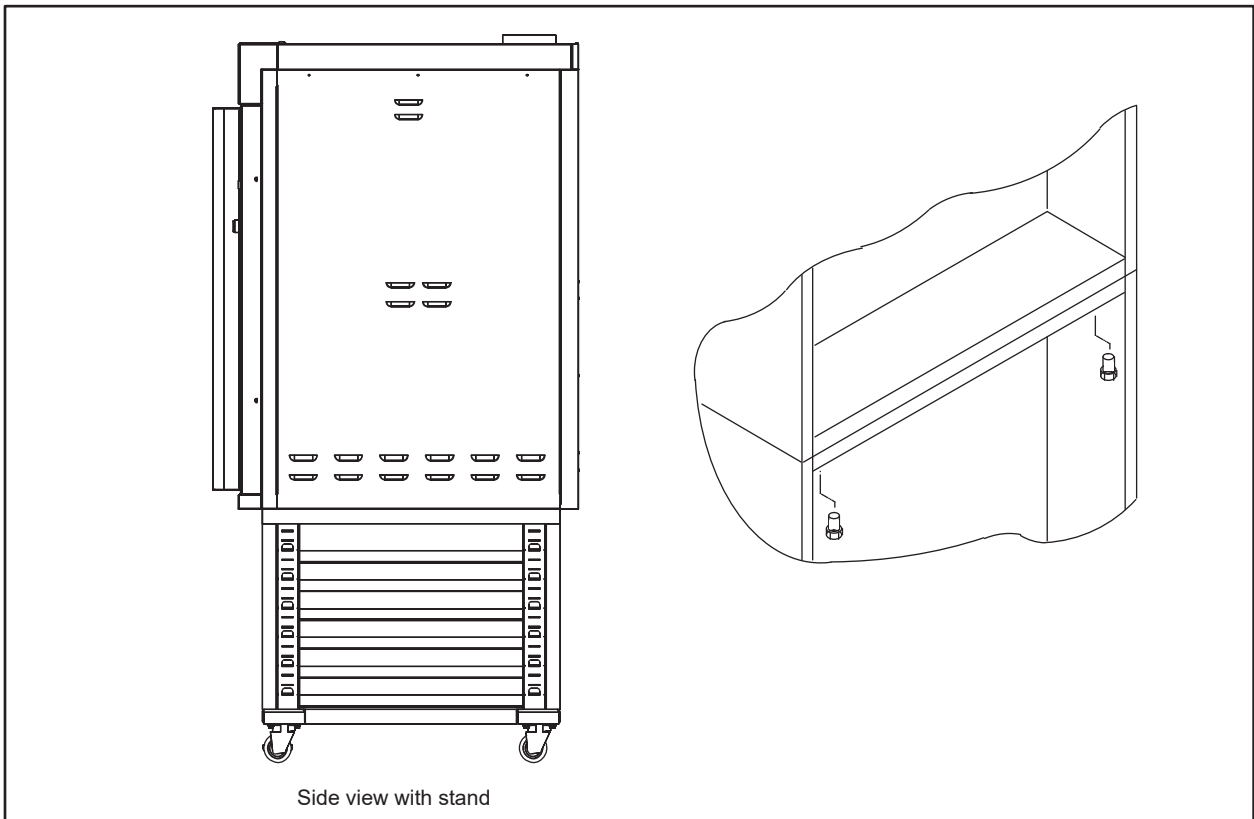

Figure 2

Ventilation (XR8-G only)

On gas models the installation of a proper ventilation system cannot be over emphasized. This system removes unwanted vapors and products of combustion from the operating area.

U.S. and Canadian installations

Refer to your local ventilation codes. In the absence of local codes, refer to the National ventilation code titled, "Standard for the Installation of Equipment for the Removal of Smoke and Grease Laden Vapors from Commercial Cooking Equipment", NFPA-96-Latest Edition.

General export installations

Installation must conform with Local and National installation standards. Local installation codes and/or requirements may vary. If you have any questions regarding the proper installation and/or operation of your Blodgett oven, please contact your local distributor. If you do not have a local distributor, please call the Blodgett Oven Company at 0011-802-658-6600.



WARNING:

Failure to properly vent the oven can be hazardous to the health of the operator and may result in operational problems, unsatisfactory baking and possible damage to the equipment.

Damage sustained as a direct result of improper ventilation will not be covered by the manufacturer's warranty.

When installed in the Commonwealth of Massachusetts, this appliance must be interlocked with the hood exhaust system so that the appliance may be operated only when the hood exhaust system is running.

Canopy Type Exhaust Hood

A mechanically driven, canopy type exhaust hood is the preferred method of ventilation. The exhaust fan should have an interlock switch with the oven to prevent the oven from operating when the exhaust fan is not running.

The hood should be sized to completely cover the equipment plus an overhang of at least 6" (15 cm) on all sides not adjacent to a wall. The distance from the floor to the lower edge of the hood should not exceed 7' (2.1m).

The total makeup and exhaust air requirements for hood capacity should be approximately 35 CFM (.99 m³/min).



Installation

Ventilation (XR8-G only)

Direct Flue Arrangement

When the installation of a mechanically driven exhaust hood is impractical the oven may be vented by a direct flue arrangement.

⚠ WARNING!!

It is essential that the direct flue be installed as follows. Incorrect installation will result in unsatisfactory baking and oven damage.

The flue must be 6" (15 cm) diameter, class B or better. The height of the flue should be compliant with the current revision of NFPA 54, Ansi Z223.1. Never direct vent the oven into a hood. The flue should be capped with a UL Listed type vent cap to isolate the unit from external environmental conditions.

The direct vent cannot replace air consumed and vented by the oven. Provisions must be made to supply the room with sufficient make-up air. Total make-up air requirements for each oven section should be approximately 35 CFM (.99 m³/min). To increase the supply air entering the room, a ventilation expert should be consulted.

Installing the draft hood

Ovens ordered for direct venting are supplied with a draft hood. Install the draft hood as follows:

1. Disconnect power to the oven.
2. Remove the two screws holding the exhaust guard. See Figure 2.
3. Install the draft hood using the screws removed in step 2. See Figure 3.
4. Reconnect power to the oven.



Figure 3



Figure 4

Utility Connections - Standards and Codes

THE INSTALLATION INSTRUCTIONS CONTAINED HEREIN ARE FOR THE USE OF QUALIFIED INSTALLATION AND SERVICE PERSONNEL ONLY. INSTALLATION OR SERVICE BY OTHER THAN QUALIFIED PERSONNEL MAY RESULT IN DAMAGE TO THE OVEN AND/OR INJURY TO THE OPERATOR.

Qualified installation personnel are individuals, a firm, a corporation, or a company which either in person or through a representative are engaged in, and responsible for:

- the installation or replacement of gas piping and the connection, installation, repair or servicing of equipment.
- the installation of electrical wiring from the electric meter, main control box or service outlet to the electric appliance.

Qualified installation personnel must be experienced in such work, familiar with all precautions required, and have complied with all requirements of state or local authorities having jurisdiction.

U.S. and Canadian installations

The installation must conform with local codes, or in the absence of local codes, with the National Fuel Gas Code, ANSI Z223.1/NFPA 54, or the Natural Gas and Propane Installation Code, CSA B149.1, as applicable.

Installation must conform with local codes, or in the absence of local codes, with the National Electrical Code, ANSI/NFPA 70-Latest Edition and/or Canadian National Electric Code C22.1 as applicable.

Appliance is to be installed with backflow prevention in accordance with applicable federal, province and local codes.

For Canada: XR8E oven must be permanently-connected per CSA C22.2#109.

Australia and general export installations

Installation must conform with Local and National installation standards. Local installation codes and/or requirements may vary. If you have any questions regarding the proper installation and/or operation of your Blodgett oven, please contact your local distributor. If you do not have a local distributor, please call the Blodgett Oven Company at 0011-802-658-6600.

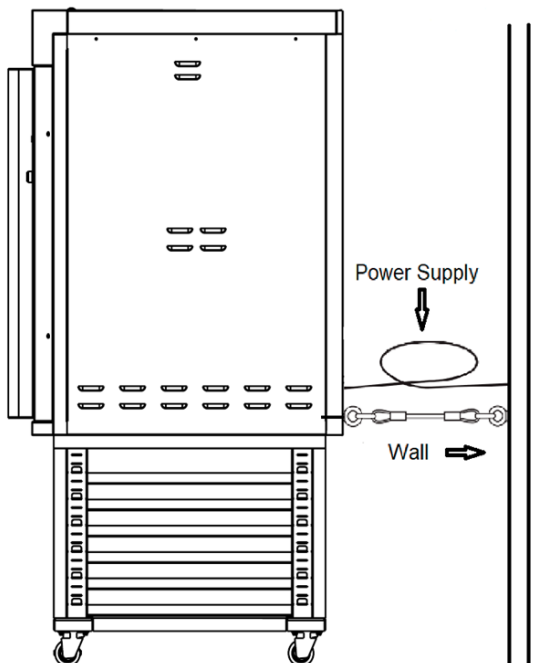

Attention

The unit must be secured against slipping by a chain or cable in order to prevent damage to the electricity supply line.

To avoid damages on the supply line, the restraint cable must be shorter than electrical connection line.



Installation

Gas Connection (XR8-G only)

GAS PIPING

A properly sized gas supply system is essential for maximum oven performance. Piping should be sized to provide a supply of gas sufficient to meet the maximum demand of all appliances on the line without loss of pressure at the equipment.

Example:

NOTE: BTU values in the following example are for natural gas.

You purchase a XR8-G rack oven to add to your existing cook line.

1. Add the BTU rating of your current appliances.

| | |
|----------------|-------------|
| Pitco Fryer | 120,000 BTU |
| 6 Burner Range | 60,000 BTU |
| Deck Oven | 50,000 BTU |
| Total | 230,000 BTU |

2. Add the BTU rating of the new oven to the total.

| | |
|----------------|-------------|
| Previous Total | 230,000 BTU |
| XR8-G | 110,000 BTU |
| New Total | 340,000 BTU |

3. Measure the distance from the gas meter to the cook line. This is the pipe length. Let's say the pipe length is 40' (12.2 m) and the pipe size is 1" (2.54 cm).

4. Use the appropriate table to determine the total capacity of your current gas piping.

The total capacity for this example is 375,000 BTU. Since the total required gas pressure, 340,000 BTU is less than 375,000 BTU, the current gas piping will not have to be increased.

NOTE: The BTU capacities given in the tables are for straight pipe lengths only. Any elbows or other fittings will decrease pipe capacities. Contact your local gas supplier if you have any questions.

Maximum Capacity of Iron Pipe in Cubic Feet of Natural Gas Per Hour

(Pressure drop of 0.5 Inch W.C.)

| PIPE LENGTH (FT) | NOMINAL SIZE, INCHES | | | | |
|------------------|----------------------|-----|--------|--------|------|
| | 3/4" | 1" | 1-1/4" | 1-1/2" | 2" |
| 10 | 360 | 680 | 1400 | 2100 | 3950 |
| 20 | 250 | 465 | 950 | 1460 | 2750 |
| 30 | 200 | 375 | 770 | 1180 | 2200 |
| 40 | 170 | 320 | 660 | 990 | 1900 |
| 50 | 151 | 285 | 580 | 900 | 1680 |
| 60 | 138 | 260 | 530 | 810 | 1520 |
| 70 | 125 | 240 | 490 | 750 | 1400 |
| 80 | 118 | 220 | 460 | 690 | 1300 |
| 90 | 110 | 205 | 430 | 650 | 1220 |
| 100 | 103 | 195 | 400 | 620 | 1150 |

From the National Fuel Gas Code Part 10 Table 10-2

Maximum Capacity of Pipe in Thousands of BTU/hr of Undiluted L.P. Gas at 11" W.C.

(Pressure drop of 0.5 Inch W.C.)

| PIPE LENGTH (FT) | OUTSIDE DIAMETER, INCHES | | |
|------------------|--------------------------|------|--------|
| | 3/4" | 1" | 1-1/2" |
| 10 | 608 | 1146 | 3525 |
| 20 | 418 | 788 | 2423 |
| 30 | 336 | 632 | 1946 |
| 40 | 287 | 541 | 1665 |
| 50 | 255 | 480 | 1476 |
| 60 | 231 | 435 | 1337 |
| 70 | 215 | 404 | 1241 |
| 80 | 198 | 372 | 1144 |
| 90 | 187 | 351 | 1079 |
| 100 | 175 | 330 | 1014 |

From the National Fuel Gas Code Part 10 Table 10-15

Gas Connection (XR8-G only)

PRESSURE REGULATION AND TESTING

XR8-G ovens are rated at 110,000 BTU/Hr. (32 kW) (116 MJ/hr). Each oven has been adjusted at the factory to operate with the type of gas specified on the rating plate.

| INLET PRESSURE | | | | |
|-------------------|---------|------|---------|------|
| | Natural | | Propane | |
| | Min | Max | Min | Max |
| W.C. | 6.0 | 14.0 | 11.0 | 14.0 |
| kPa | 1.2 | 3.5 | 2.7 | 3.5 |
| MANIFOLD PRESSURE | | | | |
| | Natural | | Propane | |
| | W.C. | | 10.0 | |
| kPa | | 2.5 | | |

- Inlet Pressure - the pressure of the gas before it reaches the oven.
- Manifold Pressure - the pressure of the gas as it enters the main burner(s).
- Min - the minimum pressure recommended to operate the oven.
- Max - the maximum pressure at which the manufacturer warrants the oven's operation.

Each oven is supplied with a regulator to maintain the proper gas pressure. The regulator is essential to the proper operation of the oven and should not be removed. It is preset to provide the oven with 3.5" W.C. (.87 kPa) for natural gas and 10.0" W.C. (2.5 kPa) for Propane at the manifold.

DO NOT INSTALL AN ADDITIONAL REGULATOR WHERE THE OVEN CONNECTS TO THE GAS SUPPLY UNLESS THE INLET PRESSURE IS ABOVE MAXIMUM.

Prior to connecting the oven, gas lines should be thoroughly purged of all metal filings, shavings, pipe dope, and other debris. After connection, the oven should be checked for correct gas pressure.

The oven and its individual shutoff valve must be disconnected from the gas supply piping system during any pressure testing of that system at test pressures in excess of 1/2 psig (3.45kPa).

The oven must be isolated from the gas supply piping system by closing its individual manual shutoff valve during any pressure testing of the gas piping system at test pressures equal or less than 1/2 psig (3.45kPa).

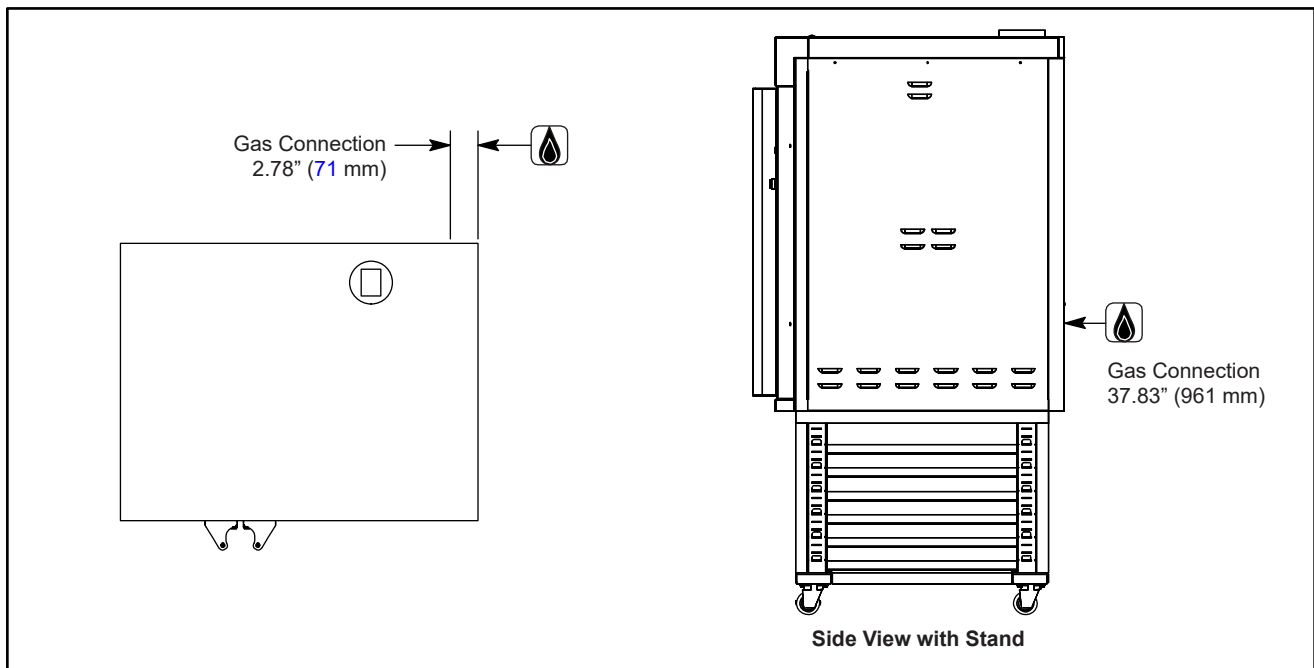

Figure 5



Installation

Gas Connection (XR8-G only)

GAS HOSE RESTRAINT

If the oven is mounted on casters, a commercial flexible connector with a minimum of 3/4" (1.9 cm) inside diameter must be used along with a quick connect device.

The restraint, supplied with the oven, must be used to limit the movement of the unit so that no strain is placed upon the flexible connector. With the restraint fully stretched the connector should be easy to install and quick connect.

The restraint (ie: heavy gauge cable) should be 1,000 lb. (453 kg) test load and should be attached without damaging the building. **DO NOT** use the gas piping or electrical conduit for the attachment of the permanent end of the restraint! Use anchor bolts in concrete or cement block. On wooden walls, drive hi test wood lag screws into the studs of the wall.

1. Mount the supplied bracket to the leg bolt below the gas inlet.
2. Attach the clip on restraining cable to the mounting bracket.

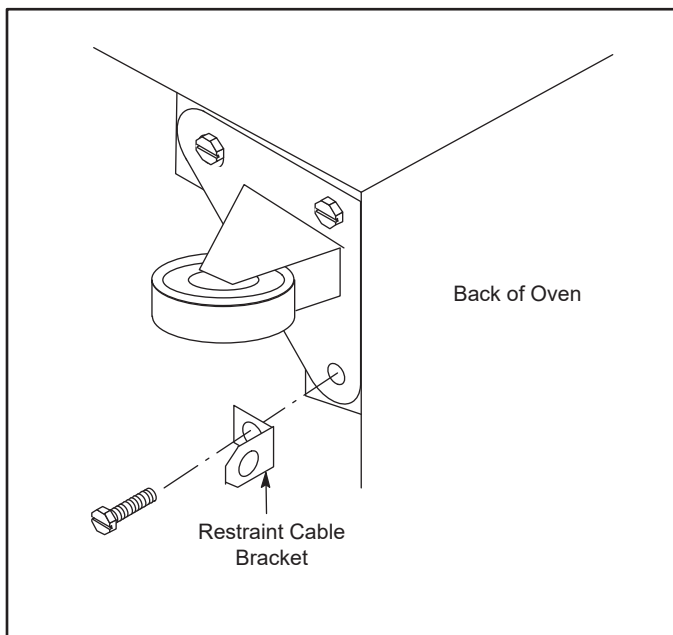

Figure 6



WARNING!!

If the restraint is disconnected for any reason it must be reconnected when the oven is returned to its original position.

U.S. and Canadian installations

The connector must comply with the Standard for Connectors for Movable Gas Appliances, ANSI Z21.69S CSA 6.16 and a quick disconnect device that complies with the Standard for Quick-Disconnect Devices for Use With Gas Fuel, ANSI Z21.41S CSA 6.9. Adequate means must be provided to limit the movement of the appliance without depending on the connection and the quick disconnect device or its associated piping.

General export installations

The restraint and quick connect must conform with Local and National installation standards. Local installation codes and/or requirements may vary. If you have any questions regarding the proper installation and/or operation of your Blodgett oven, please contact your local distributor. If you do not have a local distributor, please call the Blodgett Oven Company at 0011-802-658-6600.

Plumbing and Electrical Connections

PLUMBING CONNECTIONS

WARNING!!

Plumbing connections must comply with applicable sanitary, safety and plumbing codes.

Water Connections

Water supply should meet the following conditions. Consult your local water company before installing the oven.

- Hardness of 4-6 grains per gallon (100ppm max)
 - PH of 6.5 to 8.0
 - Chlorides less than 30 PPM
1. Connect the cold water supply to the 3/4" MGHT connection on the back of the oven with the water line provided. Supply pressure should be 40 to 75 psi (76 to 517 kPa) when the steam solenoid is open. The water regulator on the oven itself has been preset at the factory. Adjust if necessary to obtain 27 GPH (gallons per hour) from the flow meter.

WARNING!!

Connection must be carried out by a licensed plumber, to an open or closed drain. The drain must never end directly beneath the equipment. The drain should not be located on the same side the equipment controls are located.

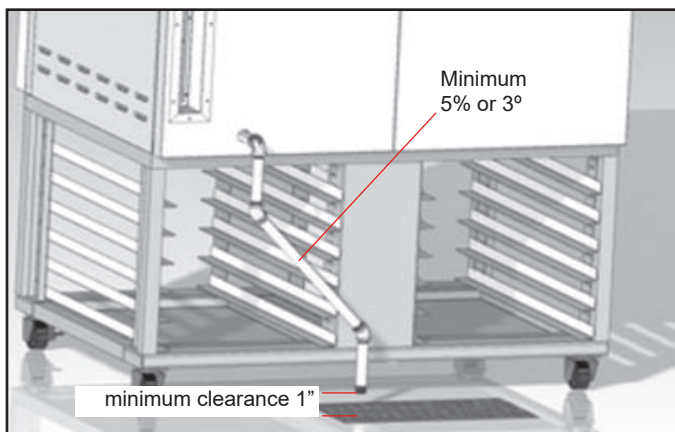

Figure 7

This product must be installed by a licensed Plumber or Gas Fitter when installed within the Commonwealth of Massachusetts.

Drain Connections

- Use pipes capable of withstanding steam temperature, don't use hoses.
- Drain pipe needs to have constant gradient (min. 5% or 3°)
- Do not reduce the diameter of the pipe (needs to be 3/4" minimum)
- Free air venting requires minimum 1" clearance between the end of drain and the floor.

ELECTRICAL CONNECTIONS

All Models

NOTE: Electrical connections must be performed by a qualified installer only.

Before making any electrical connections to these appliances, check that the power supply is adequate for the voltage, amperage, and phase requirements stated on the rating name plate mounted on the appliance.

The circuit breaker that is used to provide power to this appliance must have a minimum of .076" (3mm) contact spacing. The circuit breaker must meet all Local and National installation standards.

All appliances must be installed in accordance with Local or National Electrical codes.

A wiring schematic is located on the inside of the removable side panel.

NOTE: Disconnect the power supply to the appliance before servicing.

WARNING!!

Improper installation may invalidate your warranty.

Electric Models

The installer must supply a cord that meets all Local and National installation standards.

Gas Models

U.S. and Canadian Installations

A power cord (115V units only) is supplied with a plug attached. Plug the power cord into the desired receptacle.

WARNING!!

If the supply cord is damaged, it must be replaced by a special cord or assembly available from the manufacturer or its service agent.



Installation

Initial Startup

The following is a check-list to be completed by **qualified technician** prior to turning on the appliance for the first time.

- Verify there are no gas leaks, by checking all gas connections with a soapy water solution. Repair leaks if necessary. (XR8-G only)
- Verify there are no water leaks to the oven. Repair leaks if necessary.
- Verify rack rotation as follows: Open oven doors and turn the power switch to ON. Close the doors and enter bake time of two minutes. Press start. Verify the rack rotates smoothly. Open the doors. Verify the rack stops square to the door opening. If rack does not rotate and fan does not circulate, door switch may be out of adjustment.

With the main burner on, check the following:

- Set the oven temperature to 300°F. Verify that the oven comes up to set temperature.
- Set a steam time of 20 seconds. Verify that the flowmeter has enough water to produce 27 GPH (gallons per hour) when the water solenoid valve is open. Adjust the oven pressure regulator if needed. The water pressure gauge, regulator and flowmeter are located behind the right side panel of the oven. Panel must be removed.
- Verify that the gas inlet pressure is correct. The inlet pressure can be checked at the pressure tap located on the gas valve. (XR8-G only)
- Verify that the manifold pressure is correct. The manifold pressure can be checked at the outlet pressure tap located on the burner gas manifold elbow located on top of the oven. (XR8-G only)
- If the above pressure readings are set to the recommended pressure requirements, allow the oven to burn-off for two hours with oven vent opened. If the pressure readings are not set correctly, turn off the oven and readjust accordingly. Then recheck pressure readings.



WARNING

The break in procedure burns off excess oils present in the metals during fabrication. Smoke may be produced. Proper ventilation is required.

ADJUSTMENTS ASSOCIATED WITH INITIAL INSTALLATION

Each oven, and its component parts, have been thoroughly tested and inspected prior to shipment. However, it is often necessary to further test or adjust the oven as part of a normal and proper installation. These adjustments are the responsibility of the installer, or dealer. Since these adjustments are not considered defects in material or workmanship, they are not covered by the Original Equipment Warranty. They include, but are not limited to:

- calibration of the thermostat
- adjustment of the doors
- burner adjustments (XR8-G only)
- leveling
- testing of gas pressure (XR8-G only)
- tightening of fasteners
- rack rotation stop position

No installation should be considered complete without proper inspection, and if necessary, adjustment by qualified installation or service personnel.

The information contained in this section is provided for the use of qualified operating personnel. Qualified operating personnel are those who have carefully read the information contained in this manual, are familiar with the functions of the oven and/or have had previous experience with the operation of the equipment described. Adherence to the procedures recommended herein will assure the achievement of optimum performance and long, trouble-free service.

Please take the time to read the following safety and operating instructions. They are the key to the successful operation of your Blodgett oven.



SAFETY TIPS

For your safety read before operating

What to do if you smell gas (XR8-G only):

- DO NOT try to light any appliance.
- DO NOT touch any electrical switches.
- Use an exterior phone to call your gas supplier immediately.
- If you cannot reach your gas supplier, call the fire department.

What to do in the event of a power failure:

- Turn all switches to off.
- DO NOT attempt to operate the oven until the power is restored.

NOTE: In the event of a shut-down of any kind, allow a five (5) minute shut off period before attempting to restart the oven.

General safety tips:

- DO NOT use tools to turn off the gas control. If the gas cannot be turned off manually do not try to repair it. Call a qualified service technician. (XR8-G only)
- If the oven needs to be moved for any reason, the gas must be turned off and disconnected from the unit before removing the restraint cable. Reconnect the restraint after the oven has been returned to its original location.
- DO NOT remove the control panel cover unless the oven is unplugged.



Operation

Standard Control

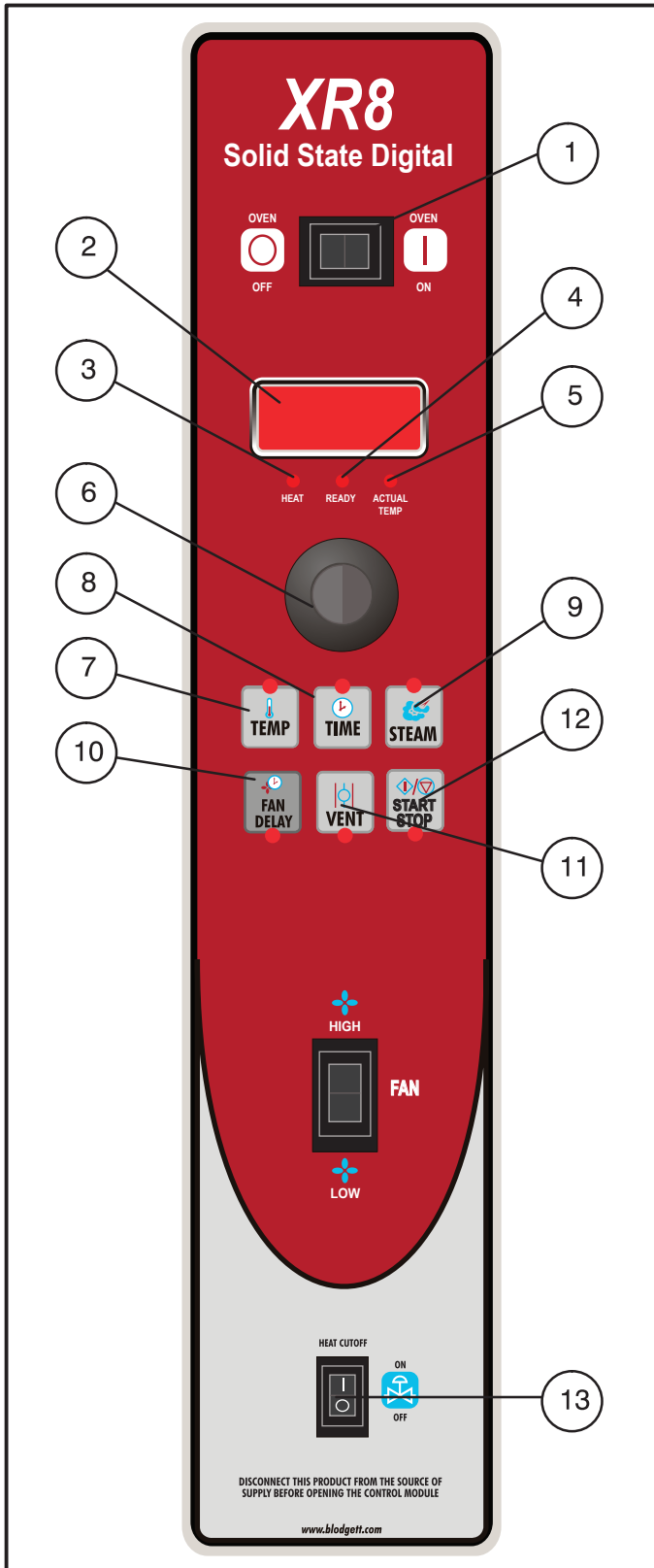

Figure 8

CONTROL DESCRIPTION

1. POWER SWITCH - controls power to the oven
2. DISPLAY - displays time, temperature and programming information
3. HEAT LED - lights when the burners are on
4. READY LED - lights when oven has reached the pre-set temperature
5. ACTUAL TEMP LED - lights when temp key is pressed, actual temp is displayed
6. SELECTION DIAL - use to enter time, temperature and programmable settings. Turn clockwise to increase or counter-clockwise to decrease values in display.
7. TEMP KEY - press to program the bake temperature or display the actual oven temperature
8. TIME KEY - press to program the bake time or display the time during a bake cycle
9. STEAM KEY - press to program steam time to inject a burst of steam
10. FAN DELAY KEY - press to program a time delay for fan and heat during and after steaming
11. VENT KEY - press to manually open and close the oven vent
12. START/STOP KEY - press to start, stop or pause the bake
13. GAS SHUTOFF SWITCH - controls gasy flow to the oven

OPERATION

Oven Startup

1. Be sure the GAS SHUTOFF SWITCH (13) is in the on position.
2. Turn the POWER SWITCH (1) to the on position. The HEAT LED (3) lights and the oven preheats to the last used set temperature.

Programming a Bake Cycle

1. Press the TEMP KEY (7). Turn the DIAL (6) to the desired bake temperature.
2. Press the TIME KEY (8). Turn the DIAL (6) to the desired bake time.
3. If steam is desired, press the STEAM KEY (9). Turn the DIAL (6) to the desired steam time. Steam may be programmed for the beginning of the bake cycle for up to two minutes.
4. If you wish to delay the rotation of the convection fan at the beginning of the bake cycle, press the FAN DELAY (10) key. Turn the DIAL (6) to the desired fan delay time.
5. Press the START/STOP KEY (12) to begin the bake cycle. The oven rack rotates.

During the Bake Cycle

1. To view the remaining bake time, press the TIME KEY (8).
2. To view the actual oven temperature, press the TEMP KEY (7).
3. To inject up to two minutes of steam during the bake cycle, press the STEAM KEY (9).
4. To vent moisture from the oven cavity, press the VENT KEY (11). This manually opens the oven vent until the key is pressed again to close it.
5. To pause a bake cycle at any point, press the START/STOP KEY (12). The cycle will pause until the key is pressed again.

At the End of the Bake Cycle

1. At the end of the bake cycle, an alarm sounds, the display reads DONE and the rack continues to rotate until the door is opened. Press the START/STOP KEY (12) to silence the alarm.
2. Open the door to remove the product.

Cool Down

1. Press the TEMP KEY (7). Turn the DIAL (6) to below 150°F.

NOTE: The doors may be opened to speed the cooling process.

Oven Shutdown

1. Turn the POWER SWITCH (1) to the off position.



Operation

MenuSelect™ Control

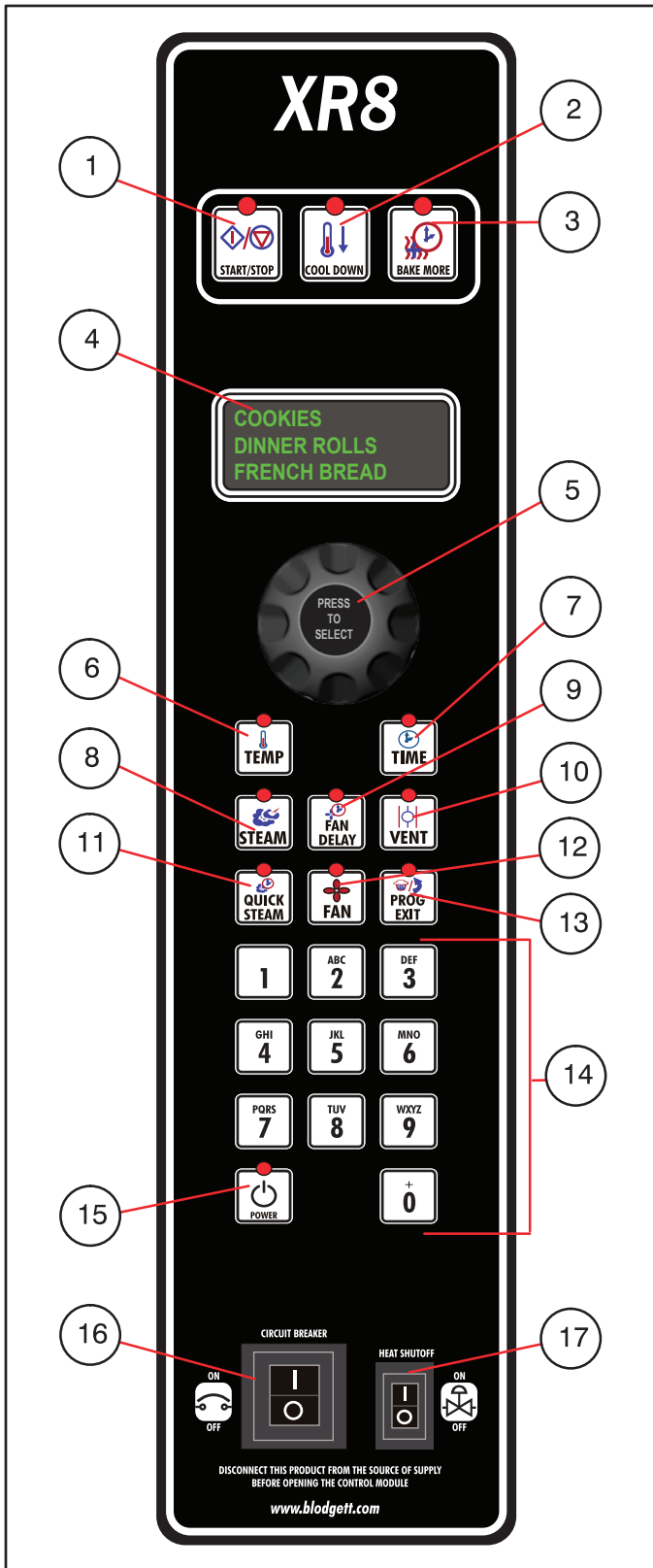

Figure 9

CONTROL DESCRIPTION

1. START/STOP KEY - press to start, cancel or pause the bake
2. COOL DOWN KEY - initiates oven cool down cycle
3. BAKE MORE KEY - press at the end of a bake cycle to add additional bake time in one minute increments.
4. DISPLAY - displays time or temperature and other information related to oven function and/or programming.
5. DIAL - used to enter set points, time, and programmable settings. Also used to select the programmed product.
6. TEMP KEY - used to set or change the bake temperature
7. TIME KEY - used to set or change the bake time.
8. STEAM KEY - used to inject steam at the start of the bake cycle or to override the steam time in a recipe.
9. FAN DELAY KEY - press to program a time delay for the convection fan
10. VENT KEY - press to manually open and close the oven vent
11. QUICK STEAM KEY - press to inject a burst of steam on demand during a bake cycle.
12. FAN KEY - press to select fan speed.
13. PROG/EXIT KEY - press to enter programming mode and save programmed settings.
14. ALPHA/NUMERIC KEYPAD - used to program recipes.
15. POWER KEY - used to place control in and out of standby mode.
16. CIRCUIT BREAKER - controls power to the oven.
17. HEAT SHUTOFF SWITCH - press to shut off gas to the oven.

OPERATION

Oven Startup

1. Be sure the GAS SHUTOFF SWITCH (17) and CIRCUIT BREAKER (16) are in the on position. The display flashes OFF PRESS POWER KEY TO START.

NOTE: If the real time clock and auto wake up functions are enabled the display reads PRESS POWER KEY TO START AUTO START.

2. Press the POWER KEY (15). The display reads PREHEAT and the oven heats to the last manual set temperature. The display flashes READY / IDLE and the alarm beeps 5 times when the oven is at temperature and ready to bake.

Manual Baking Mode

1. Turn the DIAL (5) until the display reads MANUAL.
2. Press the TIME KEY (7). Rotate the dial, or use the alpha/numeric keypad to enter the desired bake time. Press the center of the dial to set the bake time.
3. Press the TEMP KEY (6). Rotate the dial, or use the alpha/numeric keypad to enter the desired bake temperature. Press the center of the dial to set the bake temperature. The oven preheats to the new temperature.
4. To inject steam at the beginning of the bake cycle, press the STEAM KEY (8). Rotate the dial, or use the alpha/numeric keypad to enter up to two minutes of steam. Press the center of the dial to set the steam time.

NOTE: The convection fan will not run during a steam cycle. It is not necessary to set a fan delay while steaming.

5. For additional fan delay time, press the FAN DELAY KEY (9). Rotate the dial, or use the alpha/numeric keypad to enter up to 1 hour and 39 minutes. Press the center of the dial to set the fan delay.
6. When the display flashes READY / IDLE, open the doors. The rack rotates to the load/unload position. Load the product.
7. Press the START/STOP KEY (1) to begin the bake cycle. The timer counts down and the display alternates between the set and actual temperature and the name of the product.

Programmed Baking Mode

1. Turn the DIAL (5) until the name of the product is highlighted. Press the center of the dial to select. The oven preheats to the programmed temperature. The display flashes READY / IDLE and the alarm beeps 5 times when the oven is at temperature and ready to bake.
2. Open the doors. The rack rotates to the load/unload position. Load the product.
3. Press the START/STOP KEY (1) to begin the bake cycle. The timer counts down and the display alternates between the set and actual temperature and the name of the product.

During Any Bake Cycle

1. To inject up to two minutes of steam during the bake cycle, press the QUICK STEAM KEY (11).
2. To vent moisture from the oven cavity, press the VENT KEY (10). This manually opens the vent until the key is pressed again to close it.
3. To pause a bake cycle at any point, press the START/STOP KEY (1). The LED on the start/stop key flashes. The bake cycle will pause until the key is pressed again.
4. To cancel the bake cycle, press and hold the START/STOP KEY (1).

At the End of Any Bake Cycle

1. An alarm sounds, the display reads BAKE DONE.
2. If more bake time is desired, press the BAKE MORE KEY (3). This will add an additional one minute of time for each press of the key.
3. When you are satisfied with the bake, press the START/STOP KEY (1) to silence the alarm. Open the door to remove the product. The rack will rotate to the load/unload position.

Oven Shutdown

1. Press the COOL DOWN KEY (2). The display reads AUTO COOL DOWN ACTUAL TEMP. To speed up the cool down process, open the doors and press the VENT KEY (10) to open the vent.
2. When the oven has cooled down, the display reads OFF PRESS POWER KEY TO START.

NOTE: The lights shut off and the vent closes automatically at the end of the cool down cycle.



Operation

MenuSelect™ Control

USING THE USB PORT

1. Remove the cover to the USB port and insert the USB drive.
2. To turn the oven on press the POWER KEY. The display toggles between set and actual temperature.
3. Simultaneously press and hold the PROGRAM/EXIT KEY and the FAN DELAY KEY.
4. Turn the dial to highlight either COPY RECIPE FROM USB or COPY RECIPE TO USB, then press the center of the dial to select.
5. When the transfer is complete the display returns to the previous screen.
6. Press the PROGRAM/EXIT KEY.
7. Turn the dial to highlight YES. Press the center of the dial to select.
8. Remove USB drive. Replace the cover to the USB port.

PROGRAMMING

Entering the Program Mode

1. Press the PROGRAM KEY (12). If the control is password protected, the display reads ENTER CODE. Use the alpha/numeric keypad to enter the manager passcode 3124, then press the center of the dial to enter the program mode.

Naming a Product Recipe

NOTE: Use the following procedure to name a new product or edit the name of an existing product.

1. For a new recipe, turn the dial to the first open product. Press the center of the dial to select.

To edit an existing name, rotate the dial to the name to be changed. Press the center of the dial to select.
2. Use the dial to scroll down to Edit Name. Press the center of the dial to enter the edit name menu.
3. Turn the dial or use the alpha/numeric keypad to select the first character. Press the center of the dial to advance to the next character. Repeat for all remaining characters.

NOTE: Product names may be up to 10 characters long and can contain spaces. Use the #1 key to insert spaces in a recipe name.

NOTE: To select letters using the keypad, press the appropriate key once if you need the first letter on the key, twice for the second and three times for the third. For example to enter the letter L press the #5 key three times.

4. Press the PROG KEY (12) to save the name and advance to product stage programming.

Programming a Product Recipe

NOTE: The control can hold 100 recipes. Each recipe may have up to 6 cooking stages.

1. Turn the dial to highlight the name of the product to be programmed. Press the center of the dial to select the product.
2. The display reads PRODUCT NAME: STAGE 1. Press the center of the dial to select the stage.
3. Rotate the dial, or use the alpha/numeric keypad to enter the desired bake time. Press the center of the dial to set the bake time.
4. Rotate the dial, or use the alpha/numeric keypad to enter the desired bake temperature. Press the center of the dial to set the bake temperature.
5. Rotate the dial, or use the alpha/numeric keypad to enter up to two minutes of steam. Press the center of the dial to set the steam time.

NOTE: The convection fan will not run during a steam cycle. It is not necessary to set a fan delay while steaming.

6. Rotate the dial to select the desired fan speed. Choose from low or high. Press the center of the dial to set the fan speed.
7. Rotate the dial, or use the alpha/numeric keypad to enter up to 1 hour and 39 minutes of fan delay. Press the center of the dial to set the fan delay.

8. Rotate the dial, or use the alpha/numeric keypad to set the vent position. The vent may be opened from 0% to 100%. Press the center of the dial to set the vent position.
9. Rotate the dial, or use the alpha/numeric keypad to set the vent delay time. Entering a value of 0 means the vent will open at the beginning of the bake cycle. Press the center of the dial to set the vent delay time.
10. Use the dial to scroll down to PRODUCT NAME: STAGE 2. Press the center of the dial to select stage 2.
11. Repeat steps 2-10 for all remaining stages.
12. When all stages have been programmed, press the PROG KEY (12). Use the dial to scroll to SAVE. Press the center of the dial to save the program.



Operation

General Guidelines for Operating Personnel

COOK TIMES AND TEMPERATURES

Preheating the oven

Always preheat the oven before baking or roasting. We recommend preheating 50°F (28°C) above the bake temperature to offset the drop in temperature when the doors are opened and cold product is loaded into the oven. Set the thermostat to the bake temperature after the product is loaded.

Bake Time

Check the product in about half the time recommended for deck or range oven recipes. Record times and temperatures which provide best results for future reference.

NOTE: Bake time will vary with the amount of product loaded, the type of pan and the temperature.

OPERATING TIPS

Pans and Racks

Product or pan height determines how many racks are used. The oven holds up to eight 18" x 26" (45.7 x 66 cm) bun pans with 4" rackspacing.

Load the oven from the bottom, centering the pans on the rack.

Roasting

To reduce shrinkage when roasting, place meat directly on the racks. Place a sheet pan one-half full of water in the bottom rack position. The water evaporates, increasing humidity in the oven chamber. The pan catches grease from the meat, making oven cleaning easier.

Fans

The fan must be operating for the oven to heat. To avoid rippling of batter product use the following procedure.

1. Preheat the oven 25_F (14_C) above the baking temperature.
2. Load the oven with product. Close the doors.
3. Set the thermostat to the baking temperature.
4. Set the blower delay for two minutes.

Cool Down Mode

To facilitate cooling the oven to a lower temperature, press the TEMP KEY (7) and turn the DIAL (6) to the left until the display reads COOL.



Cleaning and Preventative Maintenance

CLEANING THE OVEN

Stainless steel ovens may be kept clean and in good condition with a light oil. Deposits of baked on splatter, heat tint and heavy discoloration may be removed with any non-toxic industrial stainless steel cleaner.

1. Apply cleaners when the oven is cold. Always rub with the grain of the metal.
2. Dry the oven with a clean cloth.

Clean interior parts as follows:

1. Pull up on the spring loaded pin on the bottom of the oven rack.
2. Slide the rack out of the oven and wash in your dishwasher.
3. Clean the interior of the oven cavity.
4. Reinstall the oven rack. Be sure the alignment plate on the top of the rack slides into the bracket on the top of the oven.
5. Realign the spring loaded pin.

NOTE: If the oven is moved the restraint must be reconnected after the unit is returned to it's regular position.

Weekly Cleaning

In addition to the daily cleaning it is necessary to clean the air intakes on a weekly basis. Air intakes provide necessary cooling air to the internal components. They are generally located on the rear and sides of the equipment.

PREVENTATIVE MAINTENANCE

The best preventative maintenance measures are, the proper installation of the equipment and a program for routinely cleaning the ovens.

Annual Maintenance

This oven requires no lubrication. Maintenance should be based on hours of usage. Refer to OSHA specifications for maintenance intervals.

If maintenance or repairs are required, contact your local Blodgett service company, a factory representative or the Blodgett Oven company.

NOTE: All service functions can be reached from the top of the oven or by removing the right side body panel.



WARNING!!

Always disconnect the appliance from the power supply before ser



Maintenance

Troubleshooting Guide

| POSSIBLE CAUSE(S) | SUGGESTED REMEDY |
|---|--|
| SYMPTOM: Oven will not fire. | |
| <ul style="list-style-type: none"> • Gas turned off (XR8-G only). • Oven not plugged in. • Power switch on the control panel is off. • Control set below ambient temperature. • Doors are open. • No draft on the burner (XR8-G only). | <ul style="list-style-type: none"> • Turn the gas valve to ON. • Plug in electrical supply cord. • Set the control panel to ON. • Set to desired cook temperature. • Close doors. • Check draft inducer opening. |
| SYMPTOM: Oven does not come to ready. | |
| <ul style="list-style-type: none"> • The oven has not reached preheat temperature (XR8-G only). • Gas valve not turned on completely. • The quick disconnect is not connected (XR8-G only). • Gas pressure to oven is too low (XR8-G only). • Internal problem with main temperature control. | <ul style="list-style-type: none"> • Wait for oven to reach preheat temperature. • Check the gas valve, turn on fully if necessary. • Reconnect the quick connect. Check all gas connections. • Call your local gas representative. • * |
| SYMPTOM: Convection fan does not run. | |
| <ul style="list-style-type: none"> • Oven is not plugged in. • Circuit breaker tripped. • Doors are open • Blower delay was set. | <ul style="list-style-type: none"> • Plug in electrical supply cord. • Reset the breaker. • Close doors. • Reset blower delay time. |
| SYMPTOM: General baking problems. | |
| <ul style="list-style-type: none"> • Thermostat out of calibration. • Improper oven venting. | <ul style="list-style-type: none"> • * • * |
| SYMPTOM: Rack does not stop rotating after doors are opened or rack stops in wrong position. | |
| <ul style="list-style-type: none"> • Rack rotator switch out of position | <ul style="list-style-type: none"> • Reposition rack rotator switch |
| <p><i>*Denotes remedy is a difficult operation and should be performed by qualified personnel only. It is recommended, however, that All repairs and/or adjustments be done by your local Blodgett service agency and not by the owner/operator. Blodgett cannot assume responsibility for damage as a result of servicing done by unqualified personnel.</i></p> | |

WARNING!!

Always disconnect the power supply before cleaning or servicing the oven.