

CIRCUIT DIAGRAM

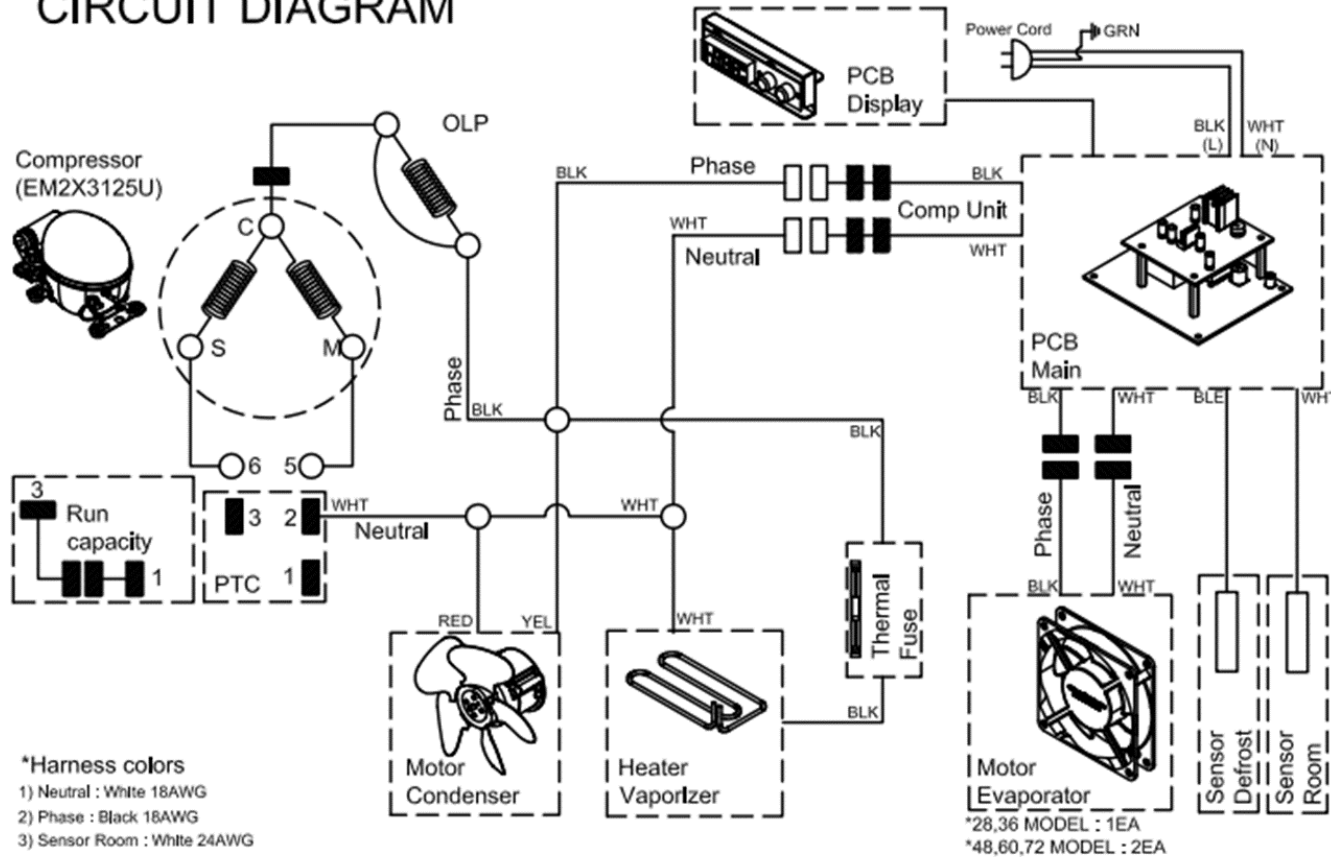

*Harness colors

- 1) Neutral : White 18AWG
- 2) Phase : Black 18AWG
- 3) Sensor Room : White 24AWG
- 4) Sensor Defrost : Blue 24AWG

WHT - WHITE BLE - BLUE
 BLK - BLACK GRN - GREEN
 RED - RED YEL - YELLOW

(115V/60Hz)

*28R,36R,48R,60R,72R-HC
 *28S,36S,48S,60S,72S-HC
 *28M,36M,48M,60M,72M-HC
 *28R-D2-HC,48R-D4-HC,
 60R-D4-HC,72R-D6-HC

*28,36 MODEL : 1EA
 *48,60,72 MODEL : 2EA

*28S-D2-HC,48S-D4-HC,
 60S-D4-HC,72S-D6-HC
 *28M-D2-HC,48M-D4-HC,
 60M-D4-HC,72M-D6-HC

PCB LAYOUT

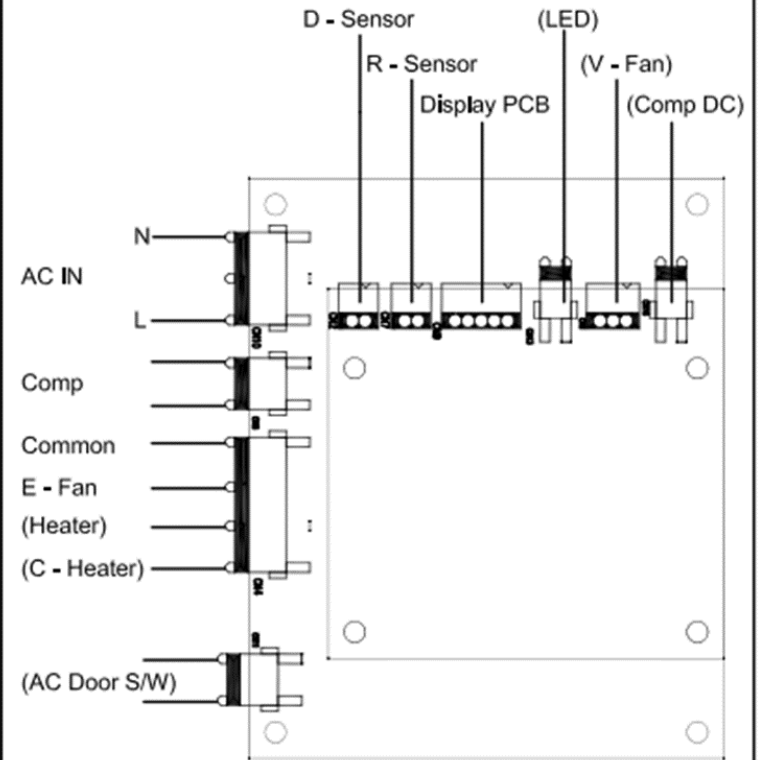

R510D-820