

BM (49RG)

CIRCUIT DIAGRAM

□□□□

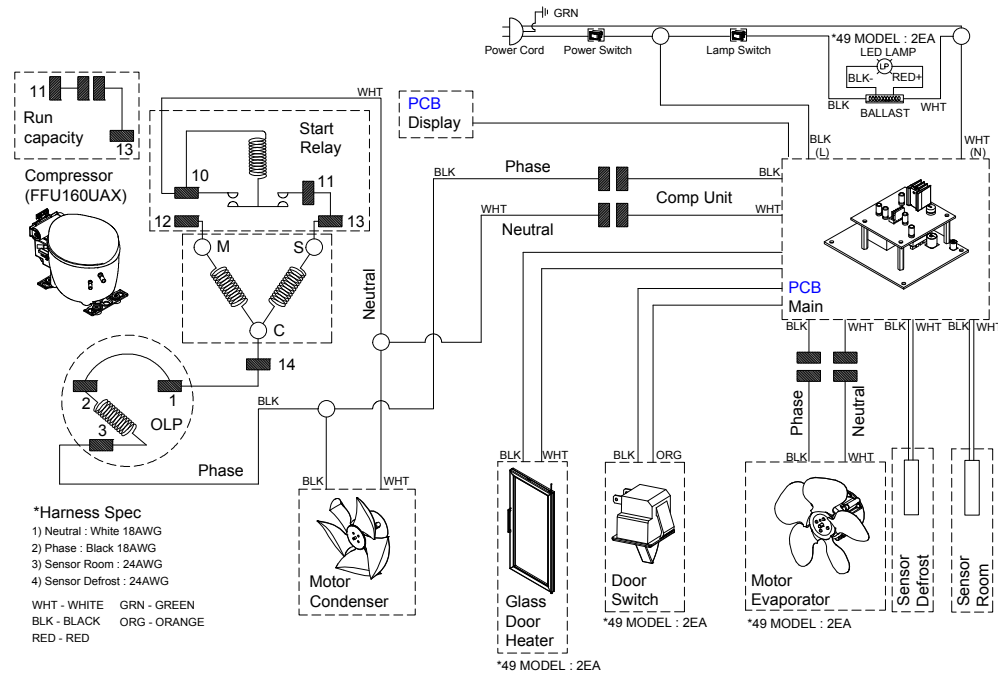

(115V/60Hz)

* 49RG-HC

PCB LAYOUT

