



CARRIER COMMERCIAL REFRIGERATION, INC.

Providing BEVERAGE-AIR • FRIGIDAIRE • KELVINATOR • UNIVERSAL NOLIN Products/Services

SERVICE & INSTALLATION MANUAL



MEDIUM TEMPERATURE VERTICAL REFRIGERATORS



01/03

51-1337-02

If additional information is necessary, call the factory.

Our toll free number is **1-800-684-1199**. Technical assistance engineers are willing to assist you in any way possible. Office hours are from 8:00 a.m. to 5:30 p.m., Eastern Standard Time.

Important information is contained in this manual which should be retained in a convenient location for future reference.

All data and information in this manual is subject to change without notice.

MODEL DESIGNATION INFORMATION

PART NO.	MODELS	STYLE	CONDENSER	SPECIAL USE
52-1923-01	BT30RF- EXPR	SOLID ONE DOOR	TOP MOUNT	EXPLOSION PROOF
52-1958-02	BT30RF-FMS	SOLID ONE DOOR	TOP MOUNT	FLAMMABLE MAT'L STORAGE
52-1993-33	BT30RG-4.1	GLASS ONE DOOR	TOP MOUNT	SCIENTIFIC GENERAL PURPOSE
52-1993-34	BT30RGCH-4.1	GLASS ONE DOOR	TOP MOUNT	CHROMATOGRAPHY
52-1993-35	BT30RS-4.1	SOLID ONE DOOR	TOP MOUNT	SCIENTIFIC GENERAL PURPOSE
52-1993-29	BT30RSFMS-4.1	SOLID ONE DOOR	TOP MOUNT	FLAMMABLE MAT'L STORAGE
52-1993-36	BT50RG-4.1	GLASS TWO DOOR	TOP MOUNT	SCIENTIFIC GENERAL PURPOSE
52-1993-37	BT50RGCH-4.1	GLASS TWO DOOR	TOP MOUNT	CHROMATOGRAPHY
52-1993-38	BT50RS-4.1	SOLID TWO DOOR	TOP MOUNT	SCIENTIFIC GENERAL PURPOSE
52-1993-30	BT50RSFMS-4.1	SOLID TWO DOOR	TOP MOUNT	FLAMMABLE MAT'L STORAGE
52-1993-39	BT80RG-4.1	GLASS THREE DOOR	TOP MOUNT	SCIENTIFIC GENERAL PURPOSE
52-1993-32	ST260RIR-4.1	SOLID ONE DOOR	TOP MOUNT	INCUBATOR
52-1993-41	ST30RGG-4.1	GLASS ONE DOOR	TOP MOUNT	BLOOD STORAGE
52-1993-42	ST50RGG-4.1	GLASS TWO DOOR	TOP MOUNT	BLOOD STORAGE
52-1991-64	T30MGP-4.1	GLASS ONE DOOR	TOP MOUNT	
52-1991-65	T30MSP-4.1	SOLID ONE DOOR	TOP MOUNT	
52-1991-66	T50MGP-4.1	GLASS TWO DOOR	TOP MOUNT	
52-1997-36	T50MGPR-4.1	GLASS TWO DOOR	TOP MOUNT	
52-1991-67	T50MSP-4.1	SOLID TWO DOOR	TOP MOUNT	
52-1991-68	T80MGP-4.1	GLASS THREE DOOR	TOP MOUNT	
52-1997-37	T80MGPR-4.1	GLASS THREE DOOR	TOP MOUNT	
52-1992-32	UMG30BS-4.1	GLASS ONE DOOR	BOTTOM MOUNT	
52-1992-33	UMG50BS-4.1	GLASS TWO DOOR	BOTTOM MOUNT	
52-1997-34	UMG50RS-4.1	GLASS TWO DOOR	BOTTOM MOUNT	
52-1992-34	UMG80BS-4.1	GLASS THREE DOOR	BOTTOM MOUNT	
52-1997-35	UMG80RS-4.1	GLASS THREE DOOR	BOTTOM MOUNT	
52-1992-35	UMH30BS-4.1	GLASS ONE DOOR	BOTTOM MOUNT	HEATED DOORS
52-1992-36	UMH50BS-4.1	GLASS TWO DOOR	BOTTOM MOUNT	HEATED DOORS
52-1992-37	UMH80BS-4.1	GLASS THREE DOOR	BOTTOM MOUNT	HEATED DOORS

Manual effective for models produced January, 2003.
Starting serial number _____.

TABLE OF CONTENTS-MED. TEMP. VERTICAL

MODEL CODES EXAMPLES	2	ELECTRICAL & REFRIGERATION INFORMATION	
HANDLING & INSTALLATION	4	BT30RF-FMS	
TOP MOUNT, GLASS PULL DOOR (1-,2-, & 3-DR MODELS)		Medium Temperature Solid 1 Door	65
Dimensional Drawings	6	ELECTRICAL & REFRIGERATION INFORMATION	
Refrigerator Specifications.....	7	BT30RF-EXPR	
BOTTOM MOUNT, GLASS PULL DOOR (1-, 2-, 3-DR MODELS)		Medium Temperature Solid 1 Door Refrigerator/Freezer	69
Dimensional Drawings	8	ELECTRICAL & REFRIGERATION INFORMATION	
Refrigerator Specifications.....	9	ST260RI, ST260RIR	
TOP MOUNT, SOLID PULL DOOR (1 & 2-DR MODELS)		Incubator	81
Dimensional Drawings & Specifications	10	TROUBLESHOOTING	93
MAINTENANCE & REPAIR	37	COMPONENT IDENTIFICATION	100
ELECTRICAL & REFRIGERATION INFORMATION		PARTS LIST	109
Medium Temperature Glass & Solid 1 Door	15		
Medium Temperature Glass & Solid 2 Door	16		
Medium Temperature Glass 3 Door	17		
Medium Temperature Solid 1 & 2 Door FMS.....	17		

Medium Temperature Vertical Refrigerators

Introduction

These refrigerators have been designed to maintain a medium temperature environment. These multi-purpose refrigerators are available in one, two, and three-door solid or glass door models.

Except for routine cleaning, these medium temperature cabinets will require little maintenance. In the unusual event that repair should be necessary, this manual presents information that is helpful in maintaining, diagnosing, and repairing these cabinets.

MODEL CODES

Kelvinator Model Example: T30LGPR-4

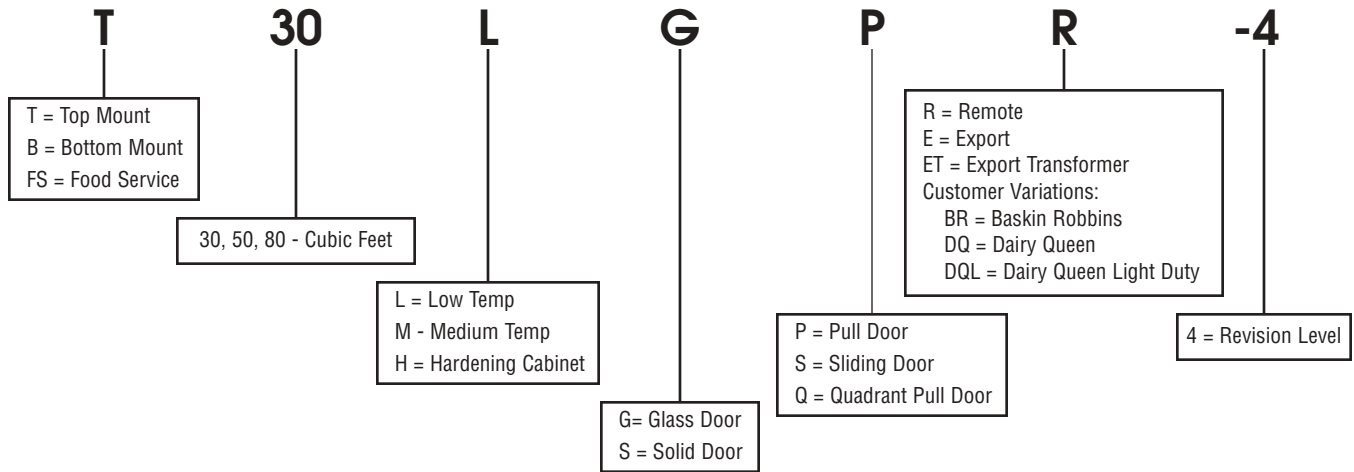

Kelvinator Scientific Model Example: ESTL50RSFMS-4



MODEL CODES

Universal Nolin Model Example: UMG50BS-4



SECTION I – HANDLING & INSTALLATION

FREIGHT DAMAGES & SHORTAGES

IMPORTANT: The cabinet was inspected and packaged at the factory, and should arrive in excellent condition. The transportation company or other parties involved in the shipment are responsible for loss and/or damage. Always make an inspection before and after uncrating. Inspect the crated unit(s) before locating (preferably at the point of unloading by the transportation company).

INSPECTING FOR DAMAGES

NOTE: Always use care when removing shipping tape, blocks, pads, hardware or other material until you are satisfied that the unit is completely operational. Contact the factory if technical assistance is required.

Check the cartons or containers. If these are damaged in any way, open them and inspect the contents in the driver's presence. If damage is detected:

1. Have the driver note the nature and extent of the damage on the freight bill.
2. Notify the transportation company at once to request an inspection. Carrier claim policies usually require inspections to be made within 15 days of delivery.
3. If damage is noticed, file a claim with the transportation company.

FILING A CLAIM

File a claim for loss at once with the transportation company for:

A. A cash adjustment; B. Repairs; or C. Replacement.

When filing your claim, retain all packaging materials and receipts.

HANDLING THE CABINET

NOTE: The refrigeration system of the cabinet is designed to operate with the cabinet located on a level surface. **Do not tilt the cabinet more than 10° to any side.** If the cabinet must be tilted on an angle for handling or moving purposes, allow it to sit in an upright position 30 minutes prior to starting.

CHOOSING A LOCATION

This model cabinet should be situated to allow proper air circulation. These cabinets require a 2" minimum clearance behind for proper air circulation.

The cabinet must be installed on sturdy, solid, level floor.

The cabinet must be located so it can be plugged into a properly grounded three-prong electrical outlet of 115 volt, 60 hz. The electrical outlet should not be controlled by a wall switch which might be turned off accidentally.

UNCRATING THE CABINET

The cabinet should be moved as close as possible to the operating location before removing crate base. Be sure to follow the steps in the "INSPECTING FOR DAMAGES" instructions.

INSTALLING THE CABINET

(Models with Top Mounted Compressor)

Whenever possible leave the crate base on the cabinet until it is moved close to the final position. When it is necessary to move the cabinet through a doorway, it may be necessary to remove the crate base.

Wood runners are provided on the underside of the cabinet for ease in sliding. These runners should be left attached to the cabinet when the crate base is removed and should remain attached until after the legs are installed. The cabinet can then be pushed around more easily without scratching the floor. The runners also prevent damage to the electrical receptacle and condensate pan hardware on the cabinet bottom.

After the cabinet has been moved to the approximate final location, remove the package containing the legs from the cabinet interior. Tape the doors to prevent accidental opening when handling. Raise the sides of the cabinet high enough to mount the legs at the locations provided on the bottom of the cabinet.

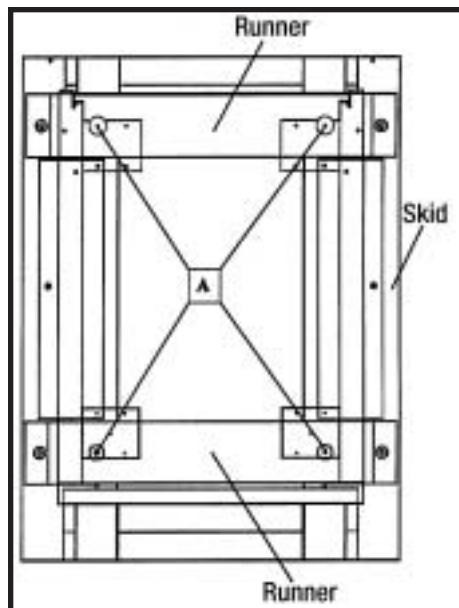

IMPORTANT:

AFTER REMOVAL OF WOOD RUNNER, REPLACE BOLT "A" INTO LEG MOUNTING BRACKETS. THIS IS EXTREMELY IMPORTANT TO THE SECURE ATTACHMENT OF THE CABINET LEG. THERE MUST BE FOUR (4) BOLTS SECURING EACH LEG.

Level the cabinet by means of the leg adjustments. Cabinet doors are self-closing, and the cabinet must be level to operate properly.

CONDENSATE PAN INSTALLATION INSTRUCTIONS

MAKE SURE THE CABINET IS DISCONNECTED
FROM ITS POWER SOURCE

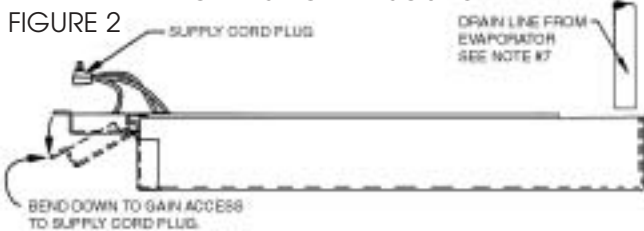

1. Remove and discard protective cover over electrical receptacle on bottom of cabinet
2. Bend down front part of housing. (See above.)
3. Insert condensate evaporator pan assembly into the slide supports on the underside of the cabinet by pushing toward back of cabinet until it stops.
4. Plug supply cord into receptacle in underside of cabinet.
5. Bend up front part of housing. Line up slot with rivnut in cabinet bottom and insert thumbscrew through slot onto rivnut in cabinet bottom. Insert thumb screw through slot onto rivnut and tighten.
6. The assembly will now operate when power is supplied to the cabinet.
7. Inspect rear of cabinet to ensure that the drain line from the evaporator is properly positioned over the condensate pan.

On top mount models, allow a minimum of twelve (12) inches between the top of the cabinet and ceiling and two (2) inches from the back of the cabinet to the wall.

(Models with Bottom Mounted Compressor)

Remove the crate base mounting clips located behind the front grill. Slide the cabinet forward on the crate base to clear the rear mounting clips.

After removing the crate base, move the cabinet into location. Make sure the cabinet is level to ensure operation of the "self-closing" doors.

Allow a minimum of two (2) inches between the back of the cabinet and the wall for proper air circulation through the condensing unit.

CABINET STARTUP

Once the cabinet has been located in its permanent location and the proper power and grounding have been provided, the following items must be checked or completed:

1. Cut and remove the compressor hold-down band (if applicable) so the compressor "floats" freely.
2. Check for traces of oil on the compressor pan which could mean a broken or leaking refrigeration line.

UNDER NO CIRCUMSTANCE SHOULD THE COMPRESSOR BE STARTED WHEN OIL IS PRESENT UNTIL INSPECTED BY A SERVICE TECHNICIAN.

3. **INSPECT THE FACTORY WIRING FOR TERMINALS THAT MIGHT HAVE VIBRATED LOOSE IN SHIPPING. TIGHTEN ALL SCREW-TYPE TERMINALS.**

4. Check the refrigeration lines to see that they are "free" and no damage was done during shipping.
5. Check fan blade(s) for "free" operation.
6. Turn on the main power switch. Once the compressor starts, the voltage should be checked at the compressor terminals to determine if there is proper voltage to the compressor. The voltage should not exceed 10% above or below the rated compressor voltage.

EXAMPLE: If the voltage reads 115 volts with no load and it drops below 103 volts when the compressor starts, it may indicate that the supply wiring is too small or that the wire run is too long.

7. Make sure that the drain line has not been dislodged or broken during shipping and that the drain trap terminates properly in the condensate pan or floor drain. (See **Condensate Pan** on top mounted compressor.)
8. Listen for any unusual noise such as lines vibrating, etc. Correct problem by tightening screws, slightly bending tubing, etc.
9. Check proper tension on doors. (See **Door Torque Adjustment**.)
10. Cabinet should not be loaded with product until cabinet has operated for 24 hours and reached desirable storage temperature.

THERMOSTAT SETTINGS

The refrigerator is shipped from the factory with a thermostat setting of approximately the mid-point of the operating range. Final thermostat setting must be made in the field.

Allow the cabinet to operate until the compressor cycles on the thermostat. The normal operating temperature range for the refrigerator is:

32°F to 55°F (0°C to 13°C)

NOTE: DO NOT OPERATE THE CABINET WITH THERMOSTAT SETTINGS BELOW 32°F (0°C).

The thermostat is easily adjusted with a standard screwdriver. The thermostat has settings 1 through 7, turn the thermostat to a higher number to lower the cabinet temperature.

The thermostat is located behind the evaporator front grill and can be adjusted through the grill. On some models the thermostat is located in the electrical box at the top of the cabinet.

SCIENTIFIC CONTROL AND ANNUNCIATOR PANELS

Cabinets for Scientific use may be equipped with a variety of optional control, alarm, and recorder devices. Each cabinet is shipped with the appropriate operators manual for the device installed on the cabinet. These operator manuals pertain to the set-up and basic operation of the control panel devices. For more comprehensive operation, repair, and maintenance information refer to the control panel service manual part number 51-0170-01.

GROUNDING INSTRUCTIONS

This appliance is equipped with a three-prong (grounding) plug for your protection against shock hazards. The appliance should be plugged directly into a properly grounded three-prong receptacle.

Where a two-prong wall receptacle is encountered, it must be replaced with a properly grounded three prong receptacle in accordance with the National Electrical Code and local codes and ordinances. The work must be done by a licensed electrician.

IMPORTANT

Do not under any circumstances cut or remove the round grounding prong from the equipment plug.

WARNING

Consult a licensed electrician if you have any doubt about the grounding of your wall receptacle. Only a licensed electrician can determine the polarization of your wall receptacle. Only a properly installed three-pronged wall receptacle assures the proper polarization with the equipment plug.

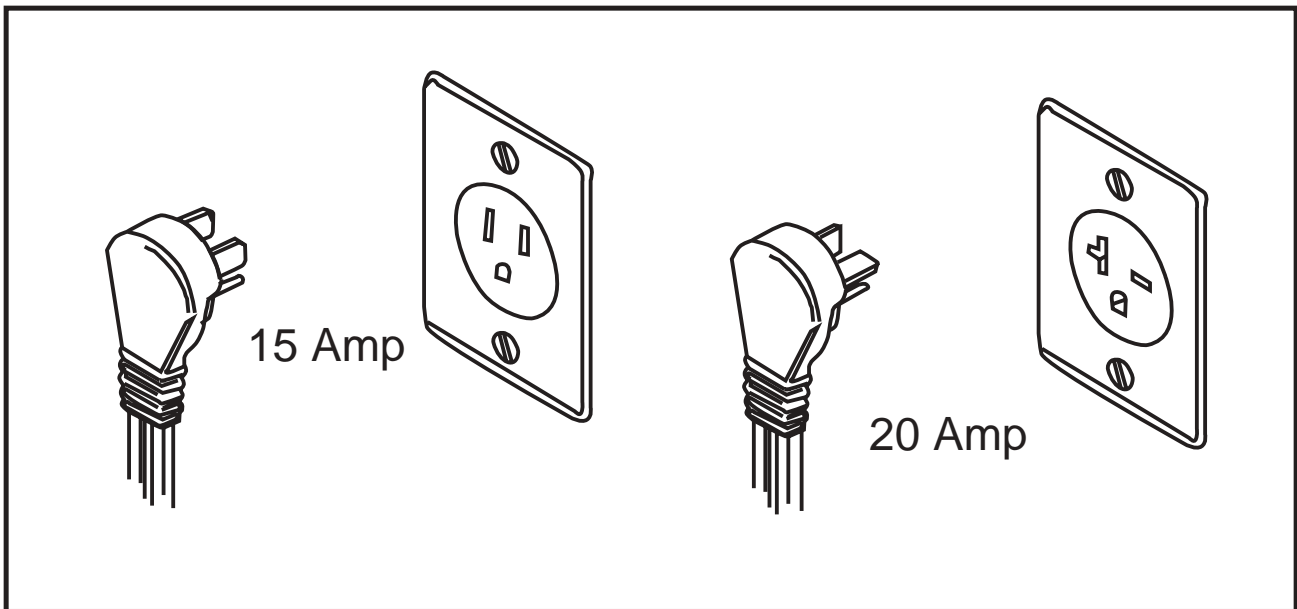

SERIAL RATING PLATES

Serial Number Rating Plates on each vertical cabinet are located on the inside upper left hand corner. This plate contains all technical data necessary to the oper-

ation of the cabinet. Warranty administration is based on the serial number as printed on the rating plate.

Medium Temperature, Top Mount, Glass Pull Door Refrigerators Dimensional Drawings

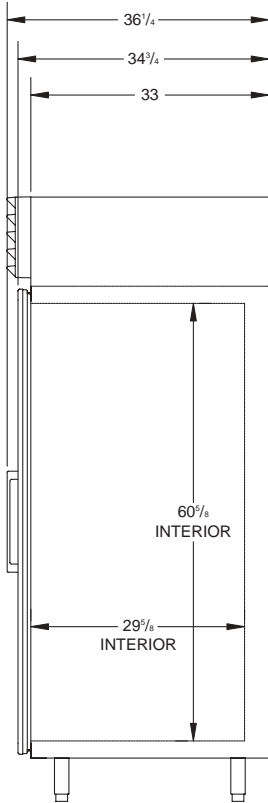
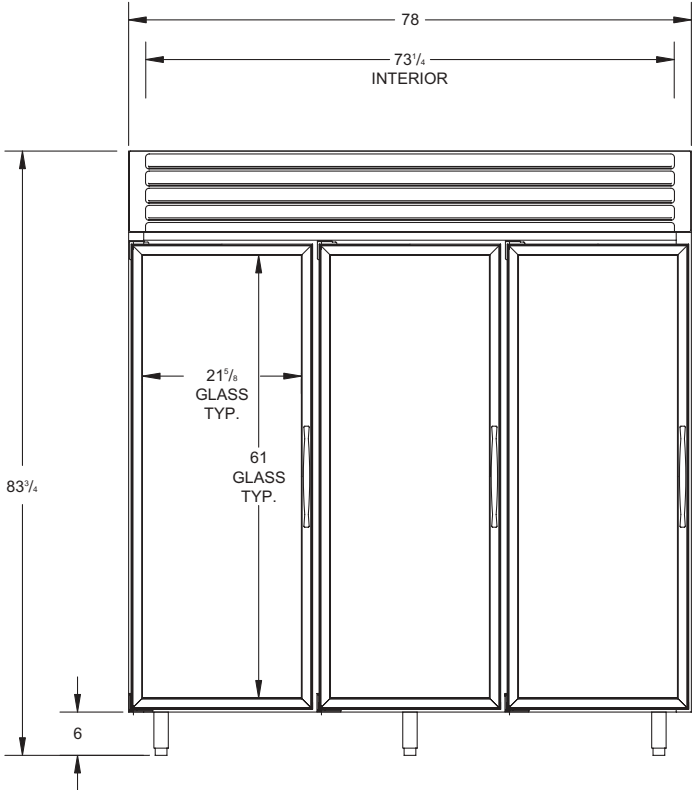
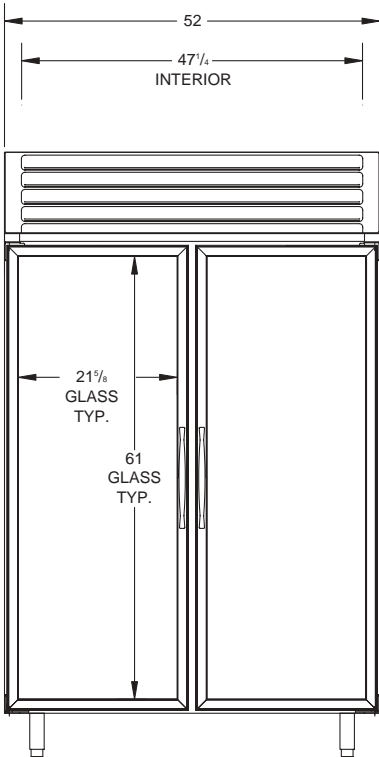
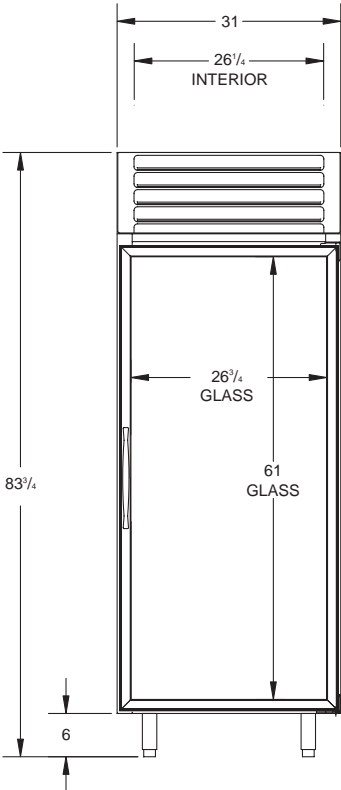

SIDE VIEW

Medium Temperature, Top Mount, Glass Pull Door Refrigerators Specifications

Specification	1-Door	2-Door	3-Door
Compressor Mount	Top	Top	Top
Temperature Range	32° to 55° (0° to 13°C)	32° to 55° (0° to 13°C)	32° to 55° (0° to 13°C)
Number of Doors	1	2	3
Door Construction	Double Pane	Double Pane	Double Pane
Hinge Type	Torsion Bar	Torsion Bar	Torsion Bar
Insulation - CFC-Free	Foam-in-Place Urethane	Foam-in-Place Urethane	Foam-in-Place Urethane
Wall Thickness	2 3/8"	2 3/8"	2 3/8"
Capacity - Gross	27.3 ft. ³	49.1 ft. ³	76.2 ft. ³
Shipping Weight (Approx.)	470 lbs.	640 lbs.	870 lbs.
Compressor BTUH/-10°F Evap.	2400	5400	5400
Condenser Type	Fin & Tube Forced Air	Fin & Tube Forced Air	Fin & Tube Forced Air
Evaporator Type	Fin & Tube Forced Air	Fin & Tube Forced Air	Fin & Tube Forced Air
Refrigerant Type	R-404A	R-404A	R-404A
Refrigerant Control	Expansion Valve	Expansion Valve	Expansion Valve
Amp Rating	9.5	12.1	14.5
	11.2 BT30RG & ST30RGG	13.8 BT50RG & ST50RGG	16.0 BG80RG
	13.2 BT30RGCH	15.8 BT50RGCH	
Electrical Specs. (V / Hz / Ph)	115 / 60 / 1	115 / 60 / 1	115 / 60 / 1
NSF	NSF7	NSF7	NSF7
UL & CSA Listed	Yes	Yes	Yes
Interior Finish	Baked Enamel, Coved Corners	Baked Enamel, Coved Corners	Baked Enamel, Coved Corners
Exterior Finish	Baked Enamel	Baked Enamel	Baked Enamel
Lighting	2 Insul. 1500 Milliamp Fluor. Lamps	3 Insul. 1500 Milliamp Fluor. Lamps	4 Insul. 1500 Milliamp Fluor. Lamps
Electrical Information	15 Amp Service Cord w/NEMA 5-15P Plug	20 Amp Service Cord w/NEMA 5-20 Plug	20 Amp Service Cord w/NEMA 5-20P Plug
	20 Amp Cord BT30RGCH w/NEMA 5-20P Plug		

Medium Temperature, Bottom Mount, Glass Pull Door Refrigerators Dimensional Drawings

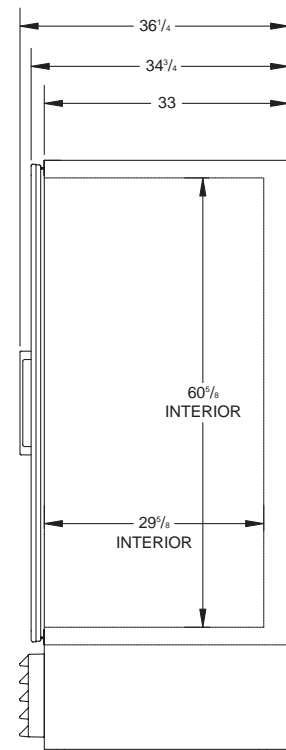
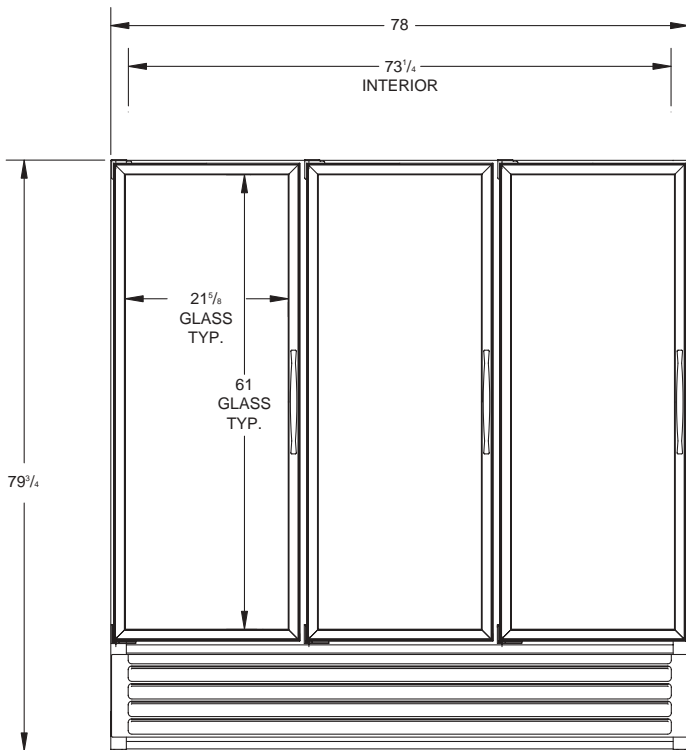
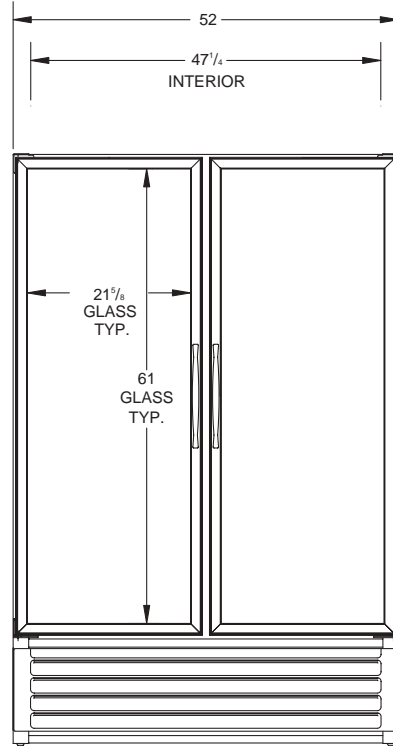
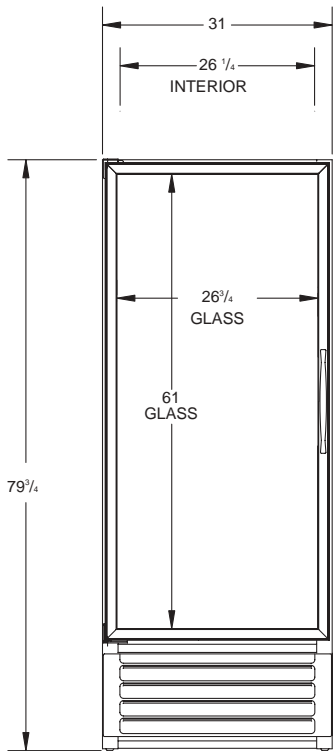

SIDE VIEW

Medium Temperature, Bottom Mount, Glass Pull Door Refrigerators Specifications

Specification	1-Door	2-Door	3-Door
Compressor Mount	Bottom	Bottom	Bottom
Temperature Range	32° to 55° (0° to 13°C)	32° to 55° (0° to 13°C)	32° to 55° (0° to 13°C)
Number of Doors	1	2	3
Door Construction	Double Pane	Double Pane	Double Pane
Hinge Type	Torsion Bar	Torsion Bar	Torsion Bar
Insulation - CFC-Free	Foam-in-Place Urethane	Foam-in-Place Urethane	Foam-in-Place Urethane
Wall Thickness	2 3/8"	2 3/8"	2 3/8"
Capacity - Gross	27.3 ft. ³	49.1 ft. ³	76.2 ft. ³
Shipping Weight (Approx.)	488 lbs.	640 lbs.	724 lbs.
Compressor BTUH/-10°F Evap.	2400	5400	5400
Condenser Type	Fin & Tube Forced Air	Fin & Tube Forced Air	Fin & Tube Forced Air
Evaporator Type	Fin & Tube Forced Air	Fin & Tube Forced Air	Fin & Tube Forced Air
Refrigerant Type	R-404A	R-404A	R-404A
Refrigerant Control	Expansion Valve	Expansion Valve	Expansion Valve
Amp Rating	9.5	12.1	14.5
Electrical Specs. (V / Hz / Ph)	115 / 60 / 1	115 / 60 / 1	115 / 60 / 1
NSF	NSF7	NSF7	NSF7
UL & CSA Listed	Yes	Yes	Yes
Interior Finish	Baked Enamel, Coved Corners	Baked Enamel, Coved Corners	Baked Enamel, Coved Corners
Exterior Finish	Baked Enamel	Baked Enamel	Baked Enamel
Lighting	2 Insul. 1500 Milliamp Fluor. Lamps	3 Insul. 1500 Milliamp Fluor. Lamps	4 Insul. 1500 Milliamp Fluor. Lamps
Electrical Information	15 Amp Service Cord w/NEMA 5-15P Plug	20 Amp Service Cord w/NEMA 5-20P Plug	20 Amp Service Cord w/NEMA 5-20P Plug

Medium Temperature, Top Mount, Solid Pull Door Dimensional Drawings

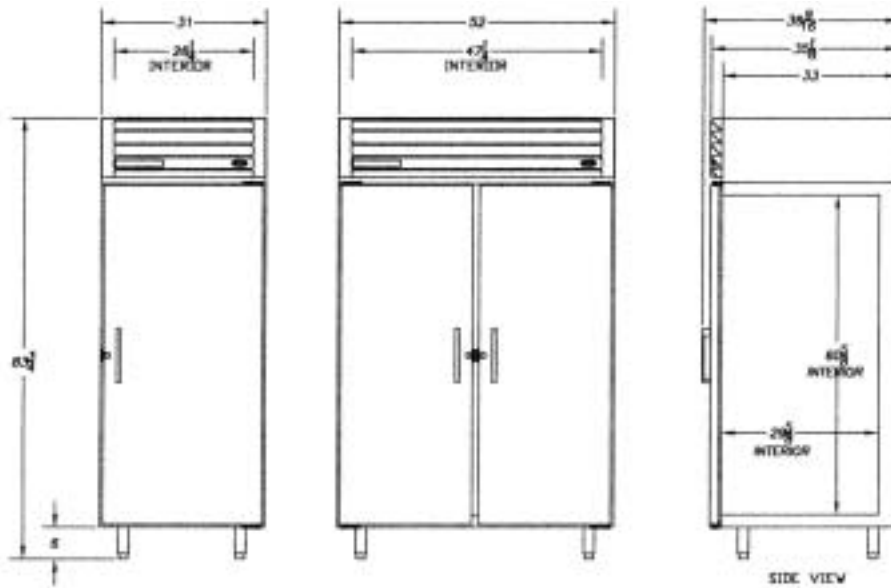

Refrigerator Specifications

Specification	1-Door	2-Door
Compressor Mount	Top	Top
Temperature Range	32° to 55° (0° to 13°C)	32° to 55° (0° to 13°C)
Number of Doors	1	2
Door Construction	Foam-In-Place	Foam-In-Place
Hinge Type	Camlift	Camlift
Insulation	Foam-in-Place Urethane	Foam-in-Place Urethane
Wall Thickness	2 3/8"	2 3/8"
Capacity - Gross	27.3 ft. ³	49.1 ft. ³
Shipping Weight (Approx.)	440 lbs.	604 lbs.
Compressor BTUH/-10°F Evap.	2126	2126
Condenser Type	Fin & Tube Forced Air	Fin & Tube Forced Air
Evaporator Type	Fin & Tube Forced Air	Fin & Tube Forced Air
Refrigerant Type	R-404A	R-404A
Refrigerant Control	Expansion Valve	Expansion Valvee
Amp Rating (80° Running)	8.7	8.7
	8.9 BT30RS	8.9 BT50RS
Electrical Specs. (V / Hz / Ph)	115 / 60 / 1	115 / 60 / 1
NSF	NSF7	NSF7
UL Listed	Yes	Yes
Interior Finish	Baked Enamel, Coved Corners	Baked Enamel, Coved Cornerss
Exterior Finish	Baked Enamel	Baked Enamel
Compressor Make	Tecumseh	Tecumseh
Electrical Information	15 Amp Service Cord w/NEMA 5-15P Plug	15 Amp Service Cord w/NEMA 5-15P Plug

SECTION II

ELECTRICAL & REFRIGERATION SPECIFICATIONS

Medium Temp., Glass, 1-Door Refrigerators

SYSTEM COMPONENTS

Compressor Model Number	Copeland ASE24C3E-IAA
Recommended Operating Temp. Range	32°F to 55°F (0°C to 13°C)
Cabinet Volts	115
Expansion Device	Sporlan FBS 1/4C BP40
Charge Refrig. Type / Oz. / Grams	R404A / 23 / 652.0

SYSTEM PERFORMANCE

AMBIENT	70°F / 21.1°C	80°F / 27°C	90°F / 32.5°C
Cavity Temp. (F/C)	40 / 4	40 / 4	41 / 5
Suction Pressure (PSIG / Kpa)	44 / 303	45 / 317	49 / 338
Discharge Pressure (PSIG / Kpa)	211 / 1455	237 / 1634	269 / 1855
Compressor Amps	6.3	6.3	6.5
Total Refrigeration Amps	8.7	8.8	9.0

Medium Temp., Solid, 1-Door Refrigerators

SYSTEM COMPONENTS

Compressor Model Number	Americold HP121-1-3087
Recommended Operating Temp. Range (F/C)	32°F to 55°F (0°C to 13°C)
Cabinet Volts	115
Expansion Device	Capillary .054 x 7"
Charge Refrig. Type / Oz. / Grams	R404A / 15 / 425.2

SYSTEM PERFORMANCE

AMBIENT	70°F / 21.1°C	80°F / 27°C	90°F / 32.5°C
Cavity Temp. (F/C)	38 / 3	38 / 3	37 / 3
Suction Pressure (PSIG / Kpa)	39 / 268	41 / 283	45 / 310
Discharge Pressure (PSIG / Kpa)	192 / 1324	217 / 1496	247 / 1703
Compressor Amps	3.9	4.0	4.2
Total Refrigeration Amps	5.7	5.8	6.0

ELECTRICAL & REFRIGERATION SPECIFICATIONS

Medium Temp., Glass, 2-Door Refrigerators

SYSTEM COMPONENTS

Compressor Model Number	Copeland AST54CIE-CAA
Recommended Operating Temp. Range	32°F to 55°F (0°C to 13°C)
Cabinet Volts	115
Expansion Device	Sporlan FBS 1/4C BP405
Charge Refrig. Type / Oz. / Grams	R404A / 23 / 652.0

SYSTEM PERFORMANCE

AMBIENT	70°F / 21.1°C	80°F / 27°C	90°F / 32.5°C
Cavity Temp. (F/C)	49 / 9	50 / 10	50 / 10
Suction Pressure (PSIG / Kpa)	48 / 331	49 / 332	50 / 345
Discharge Pressure (PSIG / Kpa)	238 / 1641	271 / 1868	306 / 2110
Compressor Amps	11.0	11.4	11.2
Total Refrigeration Amps	14.2	14.7	14.6

Medium Temp., Solid, 2-Door Refrigerators

SYSTEM COMPONENTS

Compressor Model Number	Americold HP121-1-3087
Recommended Operating Temp. Range (F/C)	32°F to 55°F (0°C to 13°C)
Cabinet Volts	115
Expansion Device	Capillary .054 x 7"
Charge Refrig. Type / Oz. / Grams	R404A / 15 / 425.2

SYSTEM PERFORMANCE

AMBIENT	70°F / 21.1°C	80°F / 27°C	90°F / 32.5°C
Cavity Temp. (F/C)	40 / 4	40 / 4	39 / 4
Suction Pressure (PSIG / Kpa)	38 / 262	42 / 289	45 / 310
Discharge Pressure (PSIG / Kpa)	196 / 1351	231 / 1593	264 / 1820
Compressor Amps	3.9	4.2	4.4
Total Refrigeration Amps	5.8	6.0	6.2
Center Mullion Heater	2.5 watt / foot	529 OHMS	115V

ELECTRICAL & REFRIGERATION SPECIFICATIONS

Medium Temp., Glass, 3-Door Refrigerators

SYSTEM COMPONENTS

Compressor Model Number	Copeland AST54CIE-CAA
Recommended Operating Temp. Range	32°F to 55°F (0°C to 13°C)
Cabinet Volts	115
Expansion Device	Sporlan FBS 1/2CP BP40
Charge Refrig. Type / Oz. / Grams	R404A / 24 / 680.4

SYSTEM PERFORMANCE

AMBIENT	70°F / 21.1°C	80°F / 27°C	90°F / 32.5°C
Cavity Temp. (F/C)	36 / 2	37 / 3	35 / 2
Suction Pressure (PSIG / Kpa)	43 / 296	42 / 289	43 / 296
Discharge Pressure (PSIG / Kpa)	205 / 1413	234 / 1648	271 / 1868
Compressor Amps	10.0	9.6	9.8
Total Refrigeration Amps	14.4	14.1	14.2

Medium Temp., Solid, 1 & 2 Door FMS

SYSTEM COMPONENTS

Compressor Model Number	Americold HP110-1-3083
Recommended Operating Temp. Range (F/C)	32°F to 55°F (0°C to 13°C)
Cabinet Volts	115
Expansion Device	Capillary .049 x 5"
Charge Refrig. Type / Oz. / Grams	R404A / 15 / 425.2

SYSTEM PERFORMANCE

AMBIENT	70°F / 21.1°C	80°F / 27°C	90°F / 32.5°C
Cavity Temp. (F/C)	41 / 5	40 / 4	38 / 3
Suction Pressure (PSIG / Kpa)	39 / 268	42 / 290	46 / 317
Discharge Pressure (PSIG / Kpa)	172 / 1186	196 / 1351	229 / 1579
Compressor Amps	1.8	1.9	2.1
Total Refrigeration Amps	3.3	3.4	3.5

WIRING DIAGRAM REFERENCE

WIRING DIAGRAM REFERENCE											
MODELS	LADDER	COMPRESSOR	ELECT BOX	DOOR SWITCH, RACEWAY	ANTI-SWEAT HTR, RACEWAY	INCAND LIGHT, RACEWAY	RECEPTACLE BOX / LIGHT	EVAPORATOR	LIGHTS, FLUORESCENT	SOLENOID	CONTROL PANEL
BT30RF-EXPR	26-0983-00										
BT30RF-FMS	00-0428-00										
BT30RG-4.1	00-0052-00	00-0137-00	00-0056-00					00-0050-01	00-0067-01		00-0058-01/02
BT30RGCH-4.1	00-0052-00	00-0137-00	00-0056-00				00-0059-00	00-0060-01	00-0067-01		00-0058-01/02
BT30RS-4.1	00-0052-00	00-0071-00	00-0056-00	00-0061-01		00-0061-05		00-0050-01			00-0058-01
BT30RSFMS-4.1	00-0055-00	00-0071-00	00-0057-00					00-0050-04			00-0058-01
BT50RG-4.1	00-0052-00	00-0084-00	00-0056-00		00-0061-04			00-0050-01	00-0067-02		00-0058-01/02
BT50RGCH-4.1	00-0052-00	00-0084-00	00-0056-00		00-0061-04		00-0059-00	00-0050-01	00-0067-02		00-0058-01/02
BT50RS-4.1	00-0052-00	00-0071-00	00-0056-00	00-0061-02	00-0061-04	00-0061-05		00-0060-01			00-0058-01
BT50RSFMS-4.1	00-0055-00	00-0071-00	00-0057-00					00-0050-04			00-0058-01
BT80RG-4.1	00-0052-00	00-0084-00	00-0056-00		00-0061-04			00-0050-01	00-0067-03		00-0058-01/02
ST260RIR-4.1	00-0053-00	00-0071-00	00-0064-00	00-0061-01	00-0061-04		00-0065-00	00-0050-03	00-0065-00		00-0017-12
ST30R-GBB-4.1	00-0052-00	00-0137-00	00-0056-00	00-0061-01				00-0050-01	00-0067-01		00-0017-10
ST50R-GBB-4.1	00-0052-00	00-0084-00	00-0056-00		00-0061-04			00-0060-01	00-0067-02		00-0017-10
T30MGP-4.1	00-0052-00	00-0137-00	00-0056-00					00-0050-01	00-0067-01		
T30MSP-4.1	00-0052-00	00-0071-00	00-0056-00					00-0050-01			
T50MGP-4.1	00-0052-00	00-0084-00	00-0056-00		00-0061-04			00-0050-01	00-0067-02		
T50MGP-4.1	00-0052-00	00-0084-00	00-0056-00		00-0061-04			00-0050-01	00-0067-02	00-0060-00	
T50MSP-4.1	00-0052-00	00-0071-00	00-0056-00		00-0061-04			00-0060-01			
T80MGP-4.1	00-0052-00	00-0084-00	00-0056-00		00-0061-04			00-0050-01	00-0067-03		
T80MGP-4.1	00-0052-00	00-0084-00	00-0056-00		00-0061-04			00-0050-01	00-0067-03	00-0060-00	
UMG30BS-4.1	00-0052-00	00-0137-00	00-0056-00		00-0061-04			00-0050-01	00-0067-01		
UMG50BS-4.1	00-0052-00	00-0084-00	00-0056-00		00-0061-04			00-0050-01	00-0067-02		
UMG50RS-4.1	00-0052-00	00-0084-00	00-0056-00		00-0061-04			00-0060-01	00-0067-02	00-0060-00	
UMG80BS-4.1	00-0052-00	00-0084-00	00-0056-00		00-0061-04			00-0050-01	00-0067-03		
UMG80RS-4.1	00-0052-00	00-0084-00	00-0056-00		00-0061-04			00-0050-01	00-0067-03	00-0060-00	
UMH30BS-4.1	00-0052-00	00-0137-00	00-0056-00		00-0061-04			00-0050-01	00-0067-01		
UMH50BS-4.1	00-0052-00	00-0084-00	00-0056-00		00-0061-04			00-0050-01	00-0067-02		
UMH80BS-4.1	00-0052-00	00-0084-00	00-0056-00		00-0061-04			00-0060-01	00-0067-03		

LADDER WIRING DIAGRAM - 00-0052-00

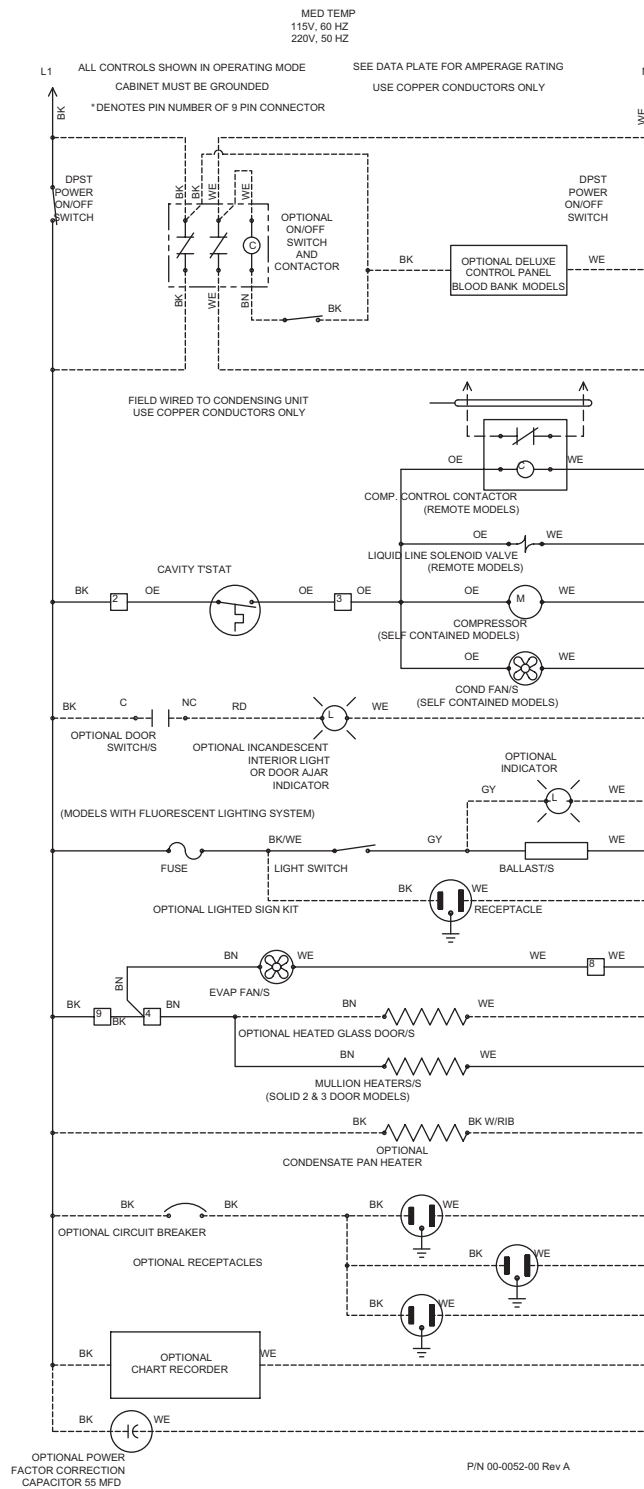

LADDER WIRING DIAGRAM - 00-0053-00

INCUBATOR
115V, 60 HZ
220V, 50 HZ

ALL CONTROLS SHOWN IN OPERATING MODE

SEE DATA PLATE FOR AMPERAGE RATING

CABINET MUST BE GROUNDED

USE COPPER CONDUCTORS ONLY

*DENOTES PIN NUMBER OF 9 PIN CONNECTOR

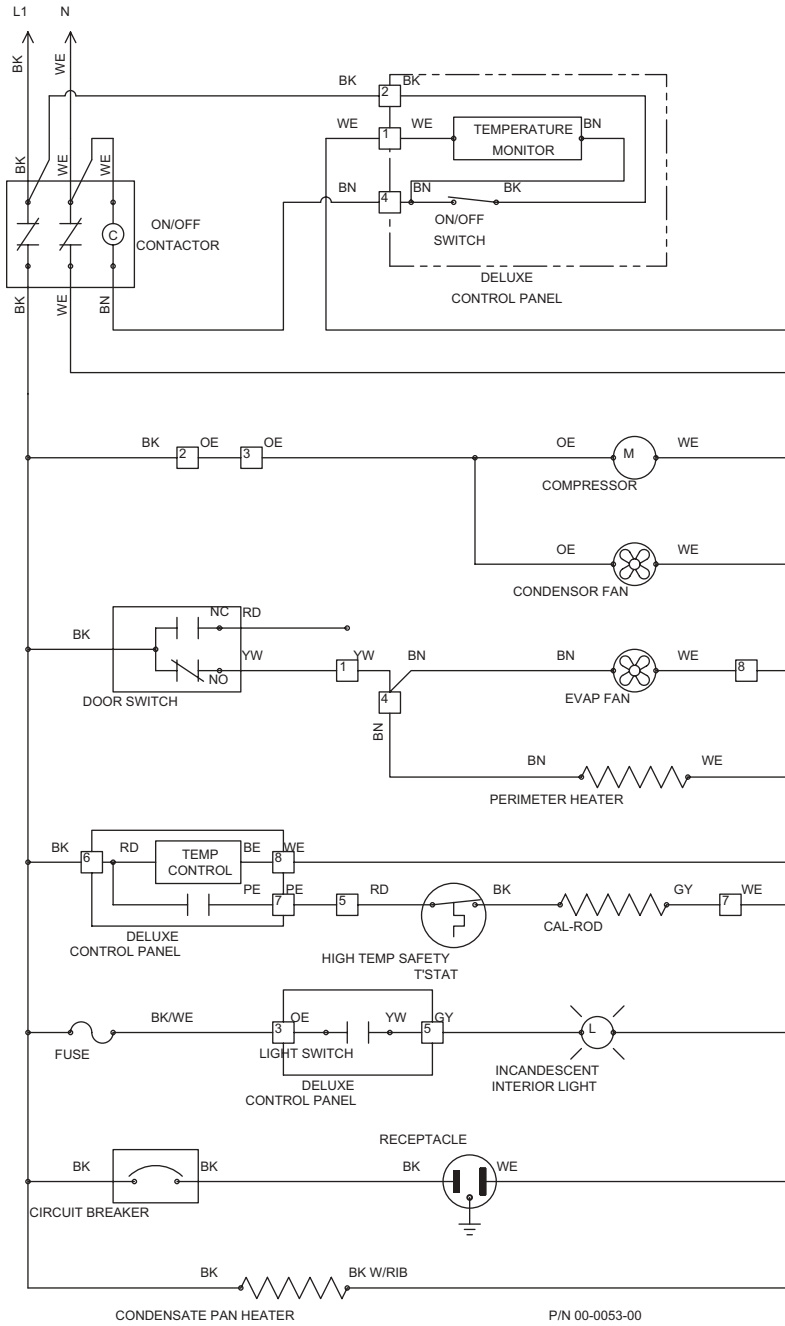

LADDER WIRING DIAGRAM - 00-0055-00

MEDIUM TEMP SCIENTIFIC
 115V, 60 HZ
 220V, 50 HZ

ALL CONTROLS SHOWN IN OPERATING MODE.

SEE DATA PLATE FOR AMPERAGE RATING

USE COPPER CONDUCTORS ONLY

CABINET MUST BE GROUNDED

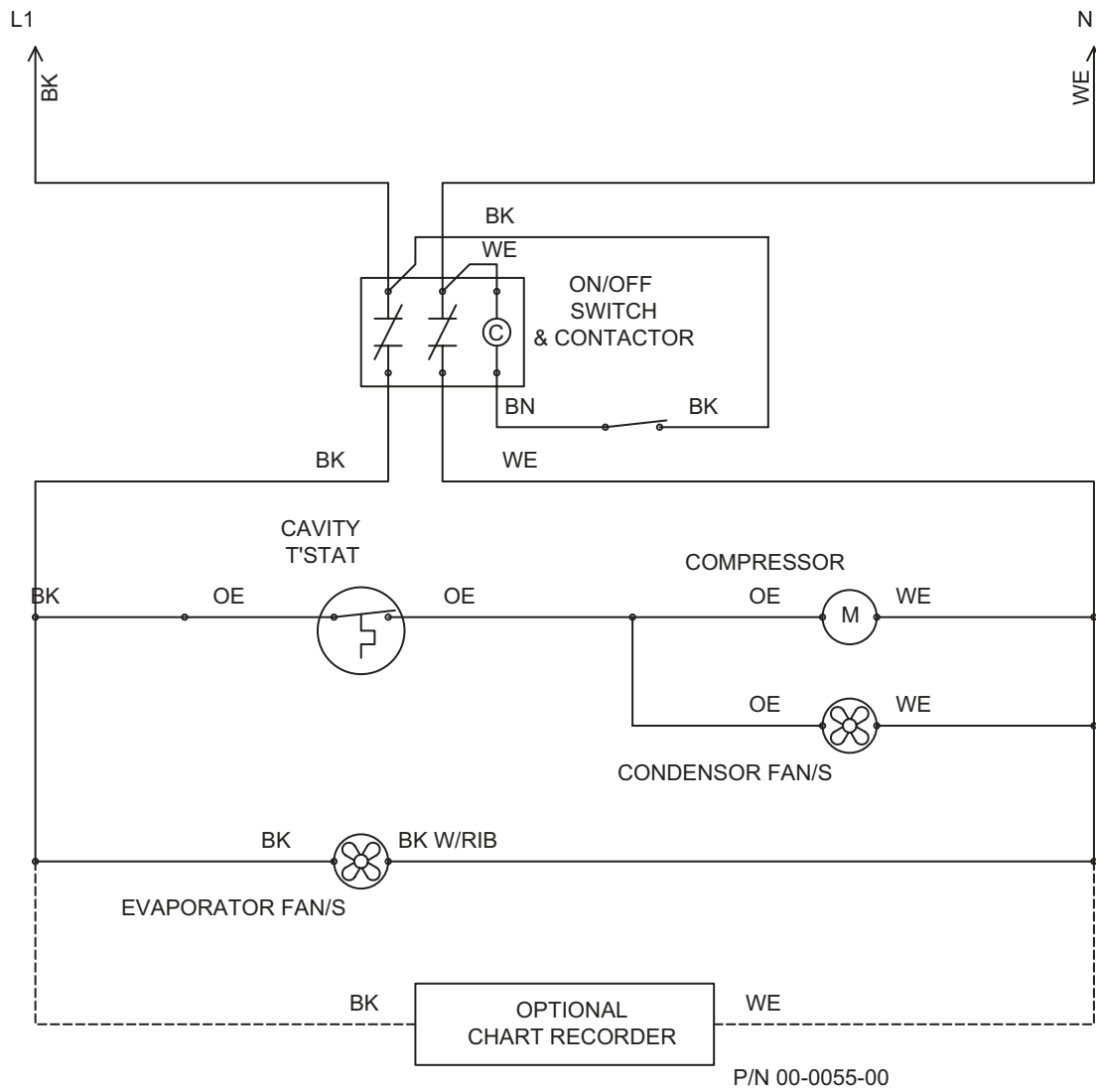

COMPRESSOR WIRING DIAGRAM - 00-0071-00

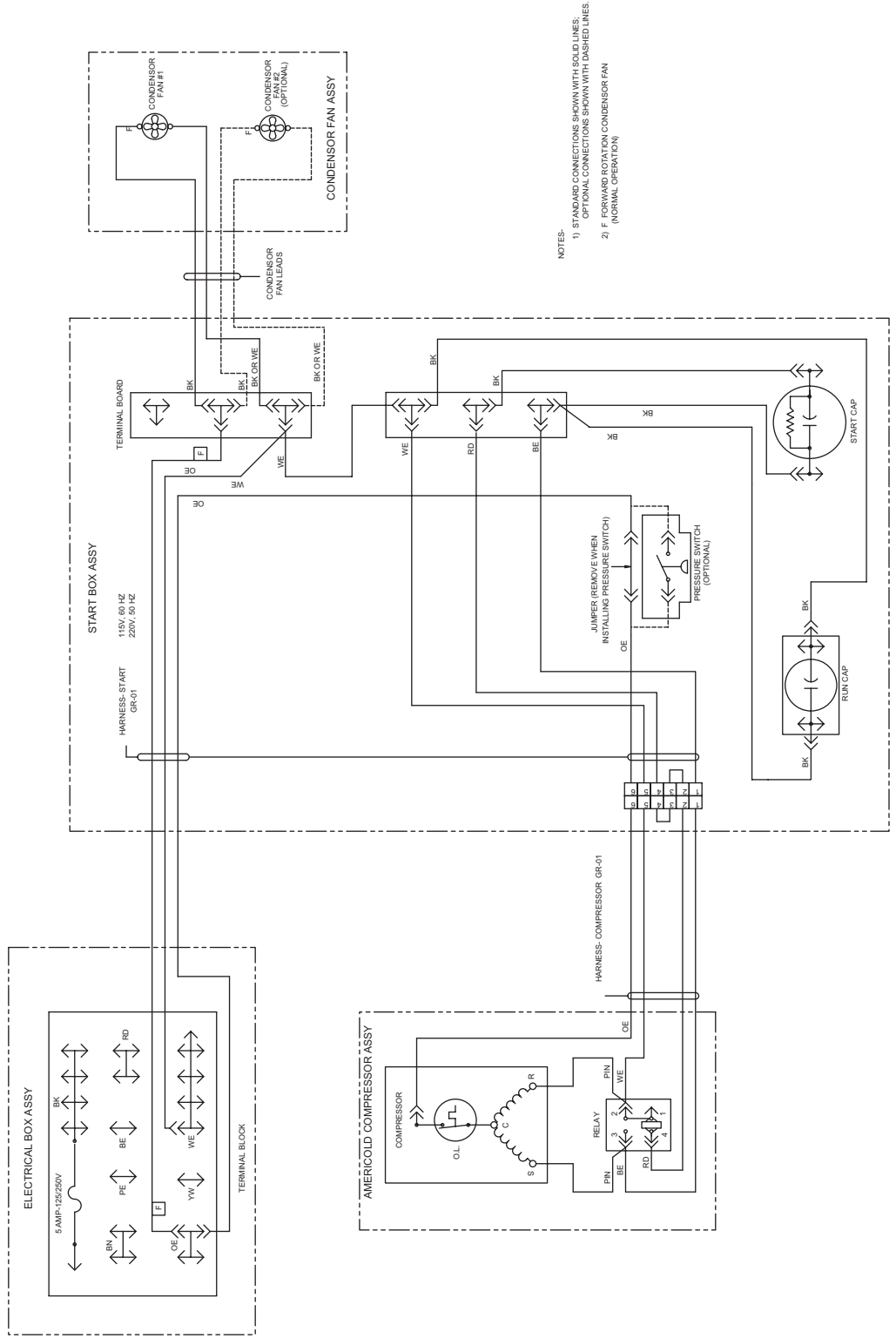

NOTES:
 1) STANDARD CONNECTIONS SHOWN WITH SOLID LINES.
 OPTIONAL CONNECTIONS SHOWN WITH DASHED LINES.
 2) F FORWARD ROTATION CONDENSOR FAN
 (NORMAL OPERATION)

COMPRESSOR WIRING DIAGRAM - 00-0084-00

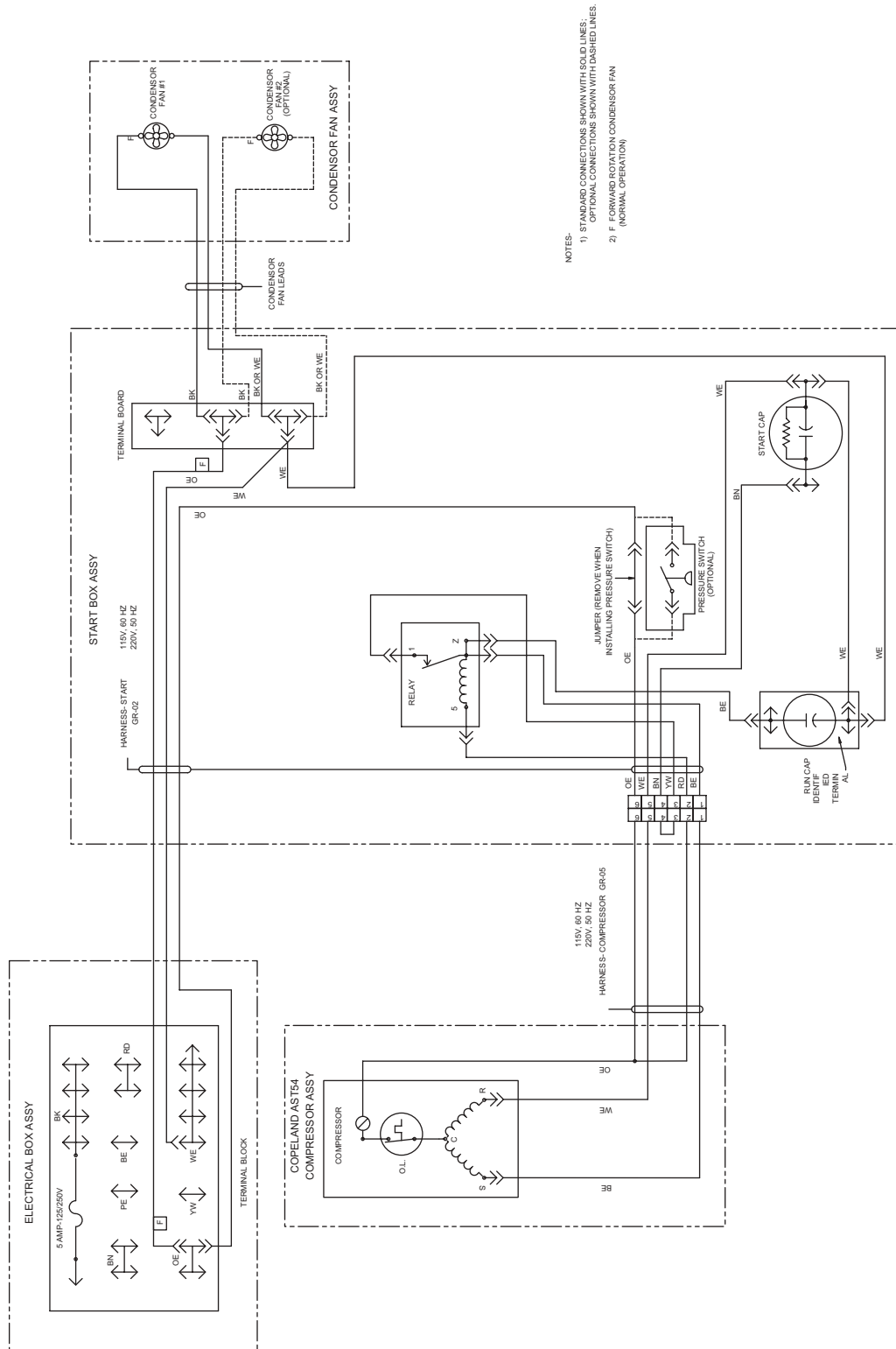

NOTES:
 1) STANDARD CONNECTIONS SHOWN WITH SOLID LINES.
 OPTIONAL CONNECTIONS SHOWN WITH DASHED LINES.
 2) F FORWARD ROTATION CONDENSOR FAN (NORMAL OPERATION)

COMPRESSOR WIRING DIAGRAM - 00-0137-00

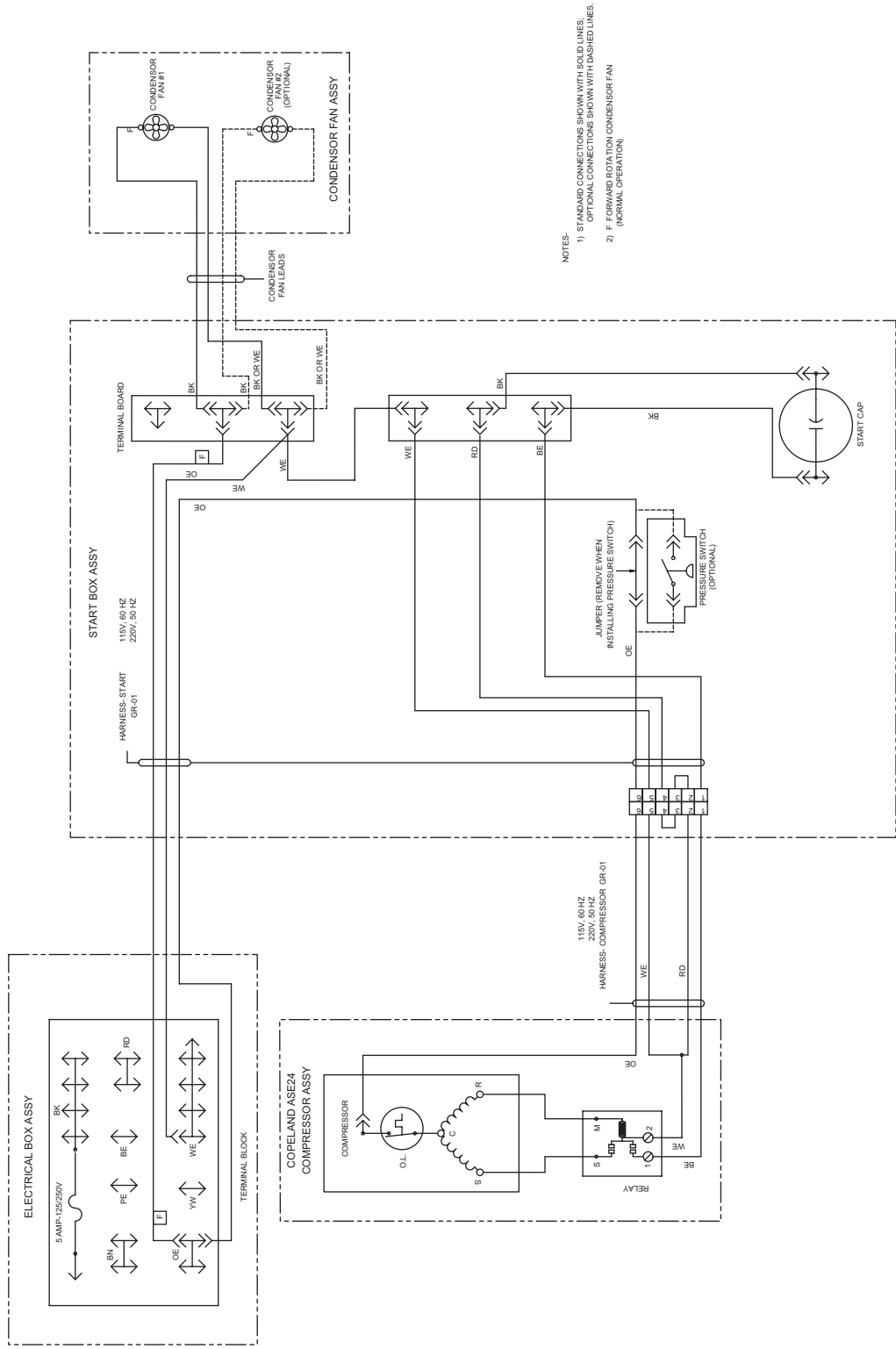

NOTES:
 1) STANDARD CONNECTIONS SHOWN WITH SOLID LINES.
 OPTIONAL CONNECTIONS SHOWN WITH DASHED LINES.
 2) F FORWARD ROTATION CONDENSOR FAN (NORMAL OPERATION)

ELECTRICAL BOX WIRING DIAGRAM - 00-0057-00

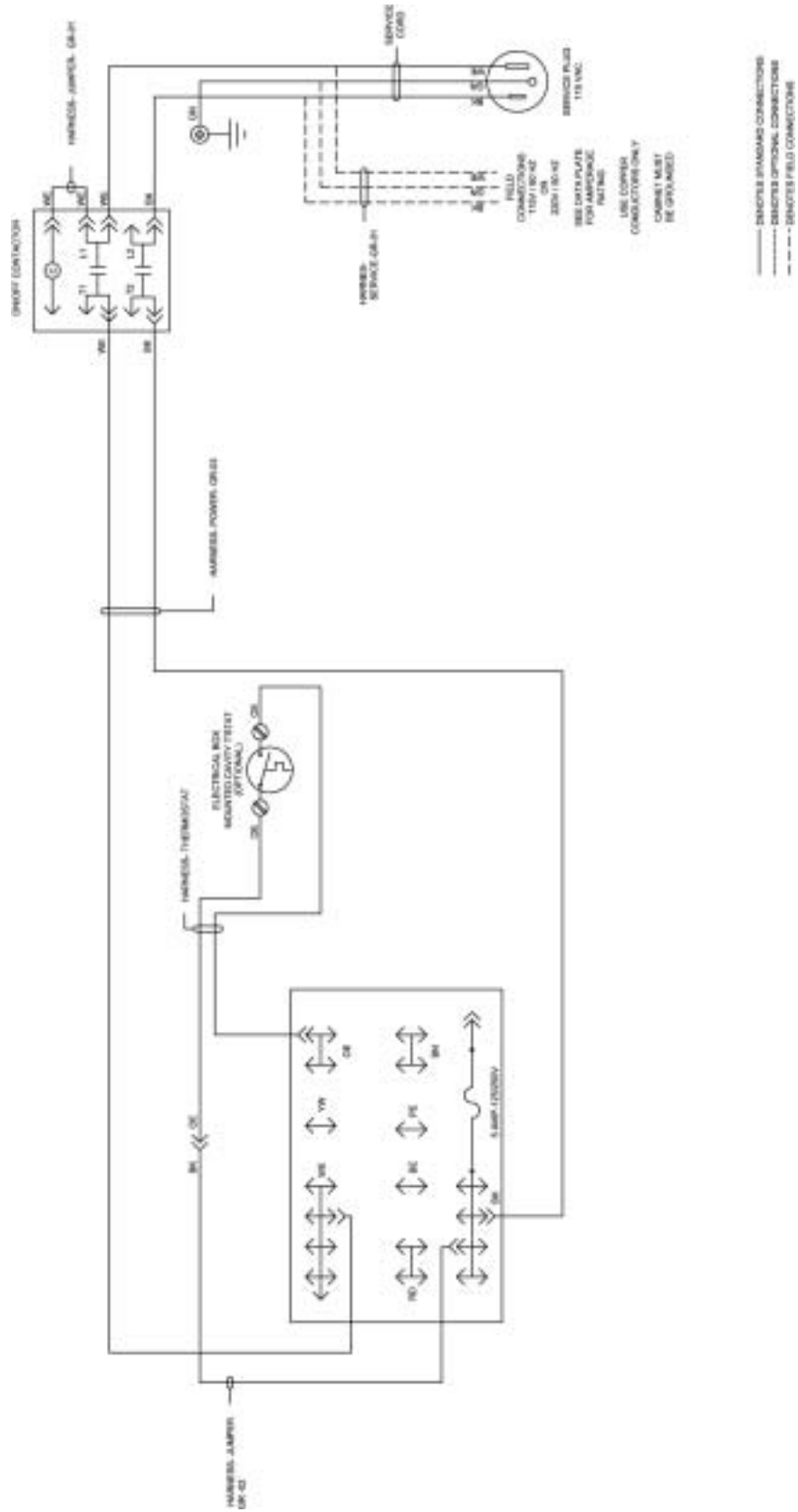

EVAPORATOR WIRING DIAGRAM - 00-0050-*

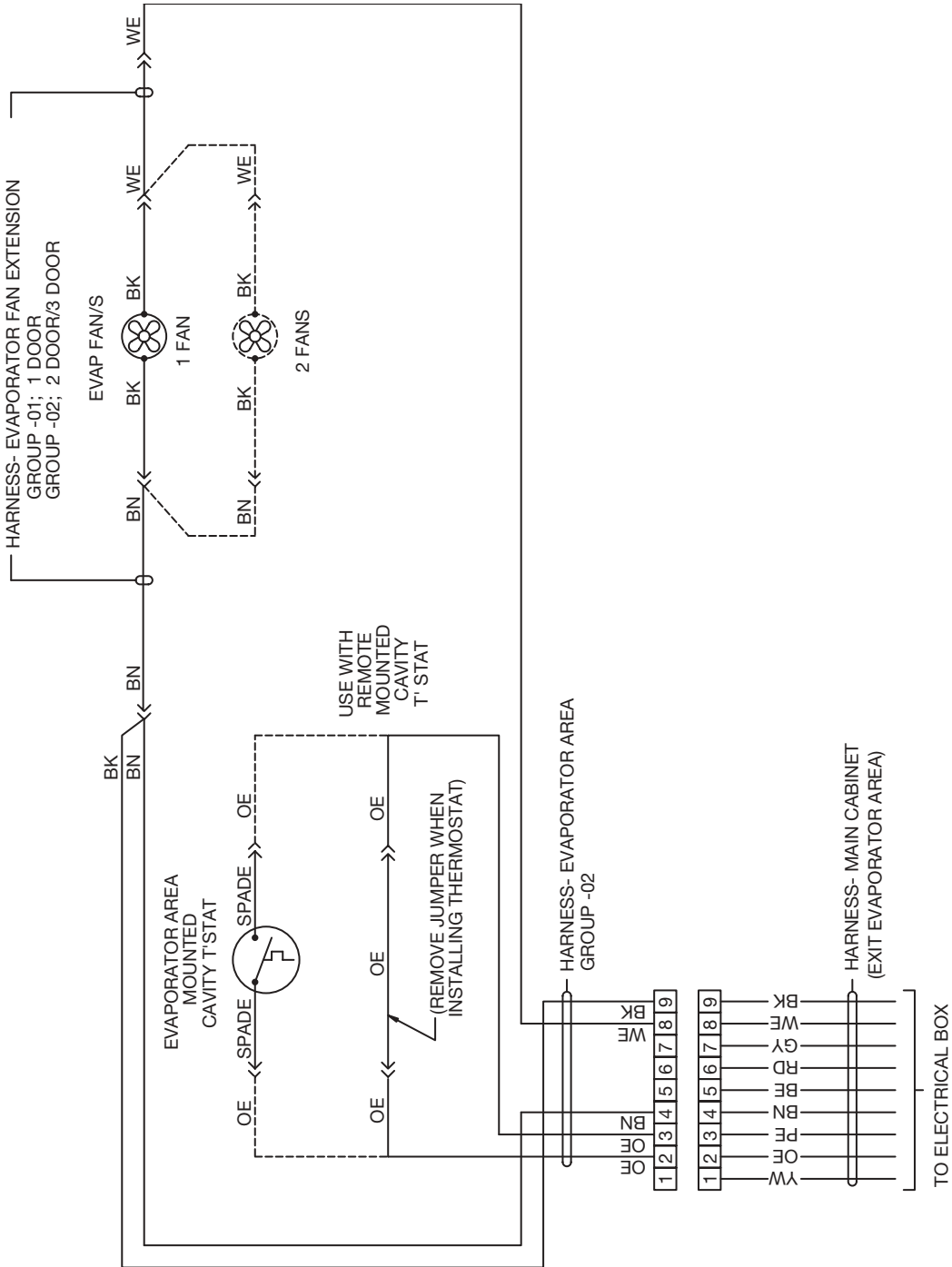

*GR.-01
MED. TEMP MODELS

FLUORESCENT LIGHT WIRING DIAGRAM - 00-0067-*

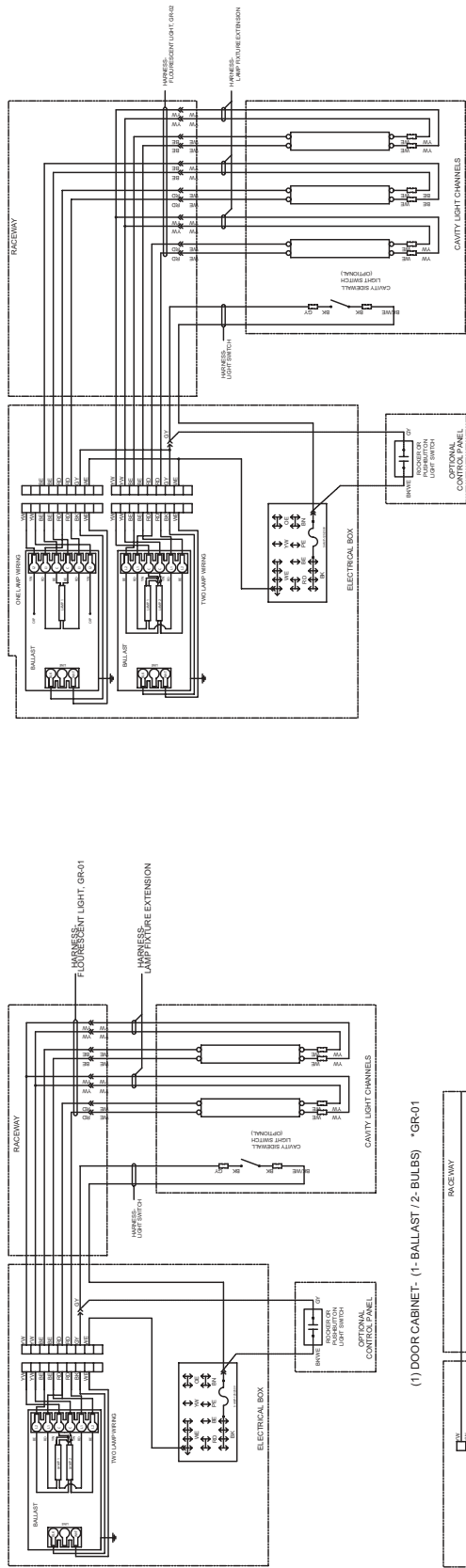

(1) DOOR CABINET - (1-BALLAST / 2-BULBS) *GR-01

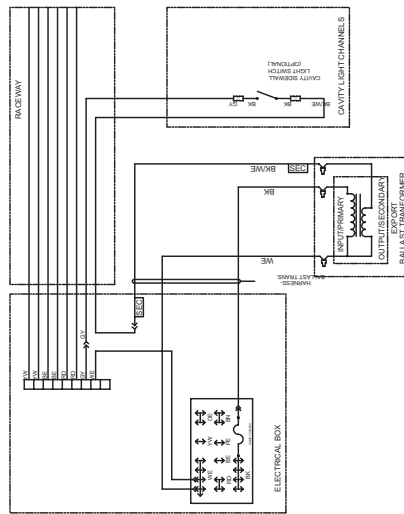

(2) DOOR CABINET - (2-BALLAST / 3-BULBS) *GR-02

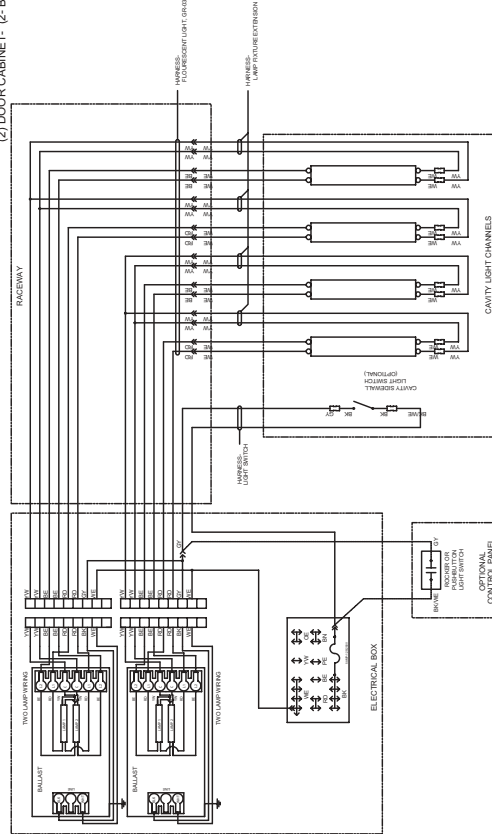

(3) DOOR CABINET - (2-BALLAST / 4-BULBS) *GR-03

TYPICAL EXPORT TRANSFORMER CONNECTIONS *GR-04

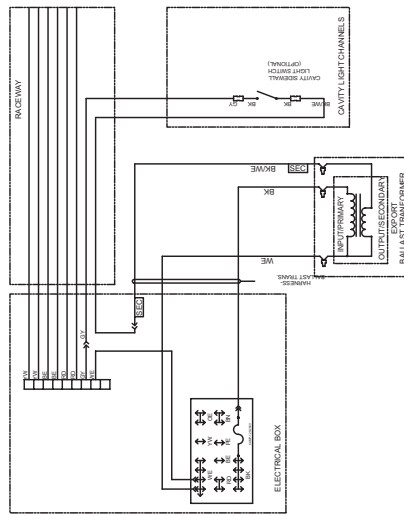

SOLENOID WIRING DIAGRAM - 00-0060-00

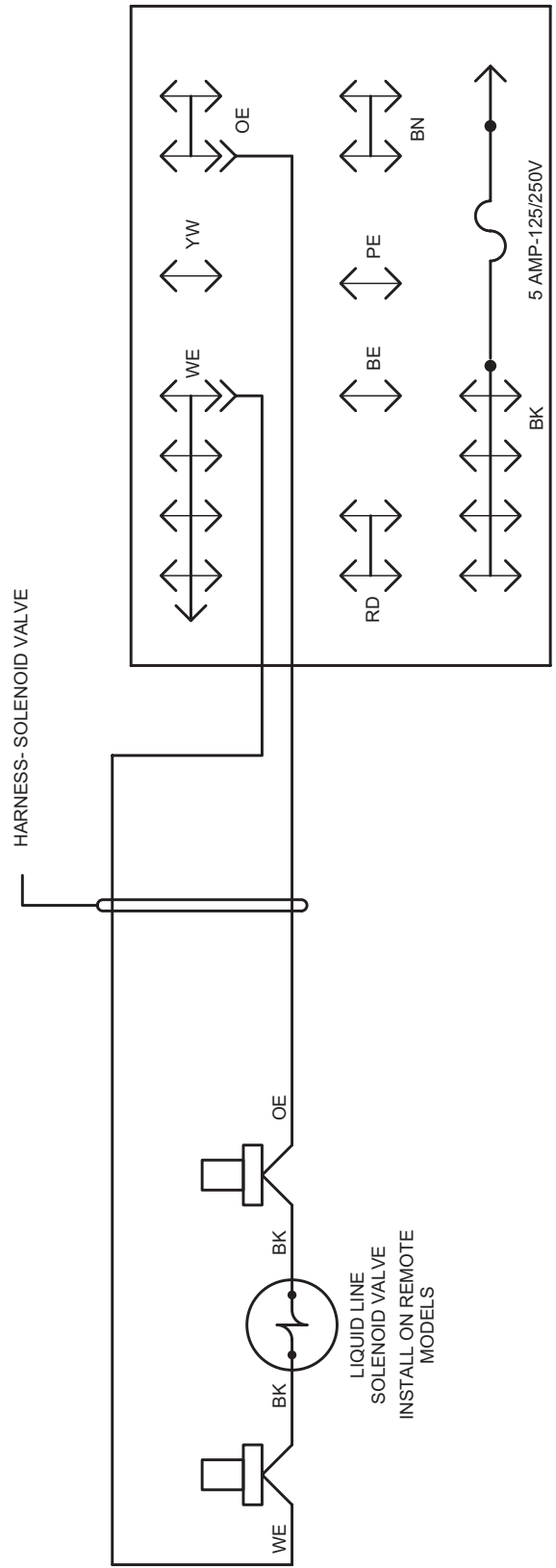

RECEPTACLE BOX/LIGHT WIRING DIAGRAM - 00-0059-00

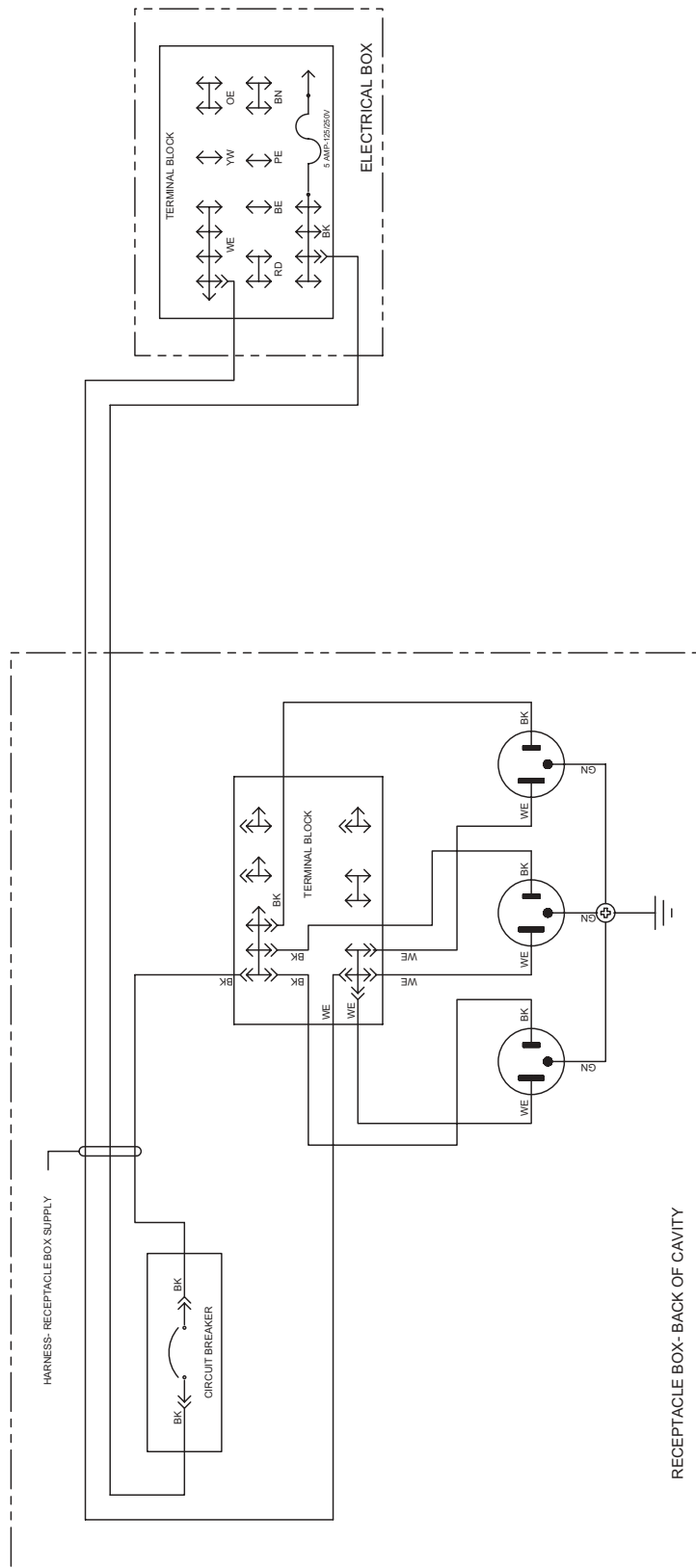

RECEPTACLE BOX/LIGHT WIRING DIAGRAM - 00-0065-00

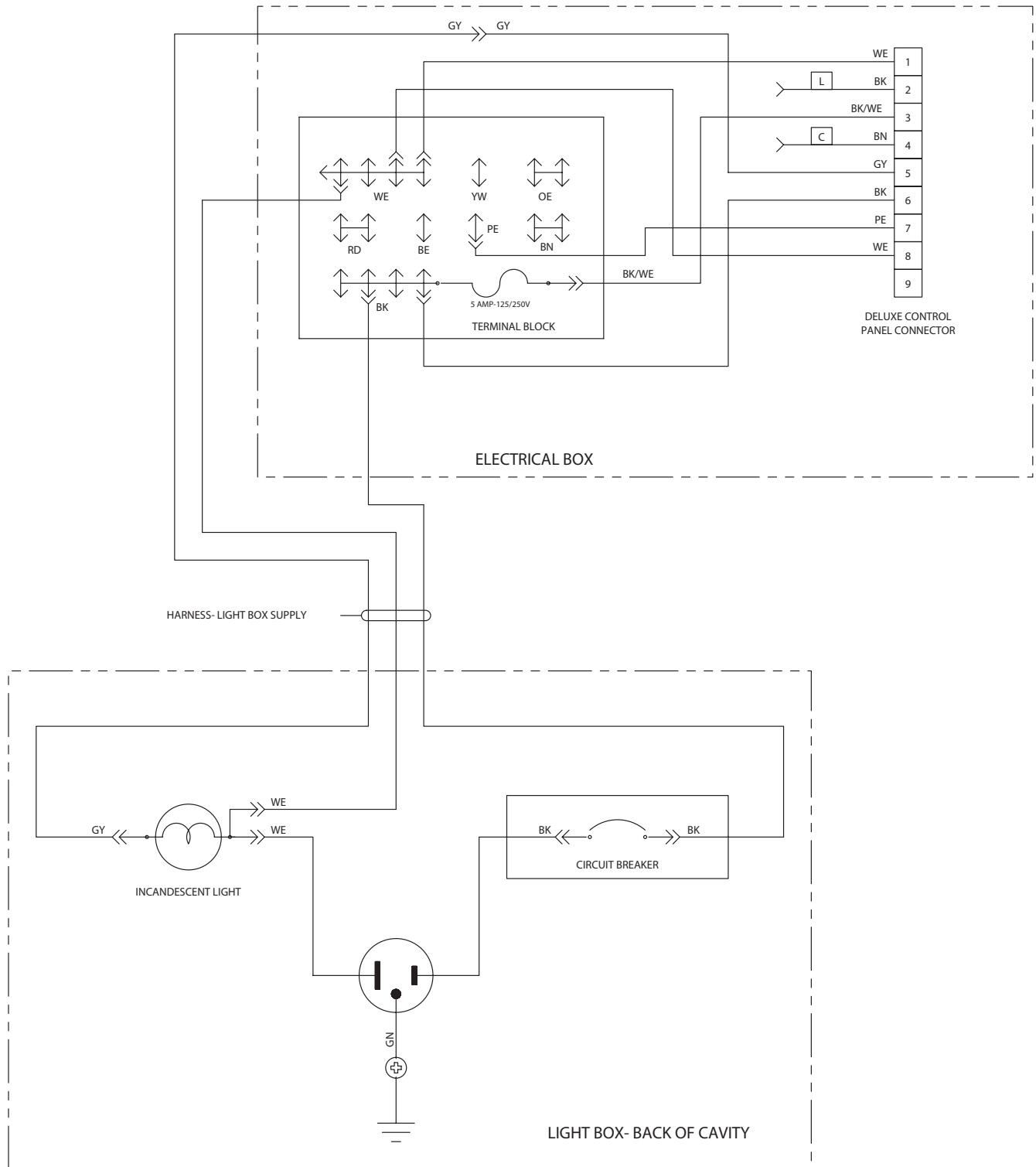

CONTROL PANEL WIRING DIAGRAM - 00-0017-10

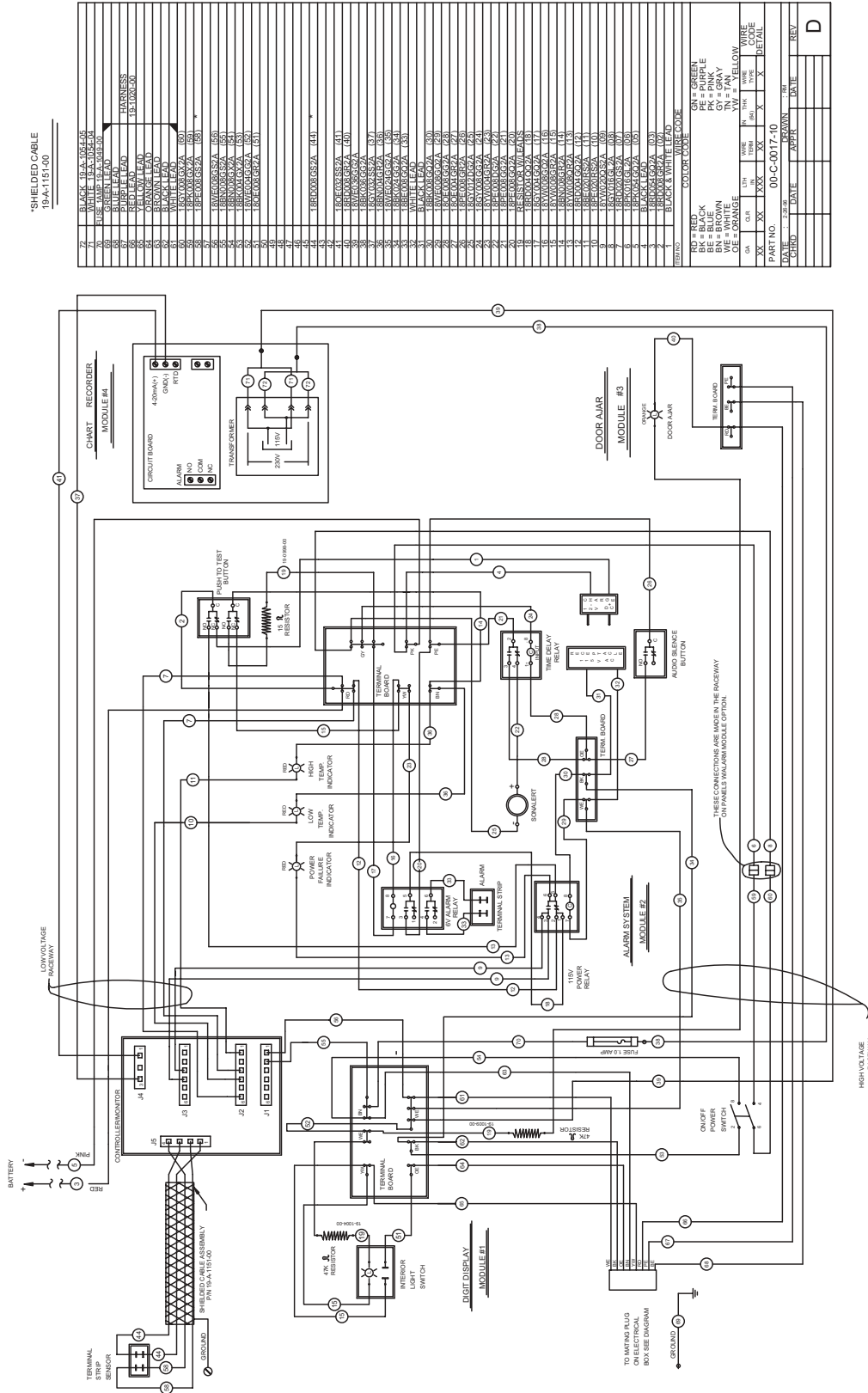

CONTROL PANEL WIRING DIAGRAM - 00-0058-*

OPTIONAL CONTROL PANEL MOUNTED ON/OFF POWER SWITCH

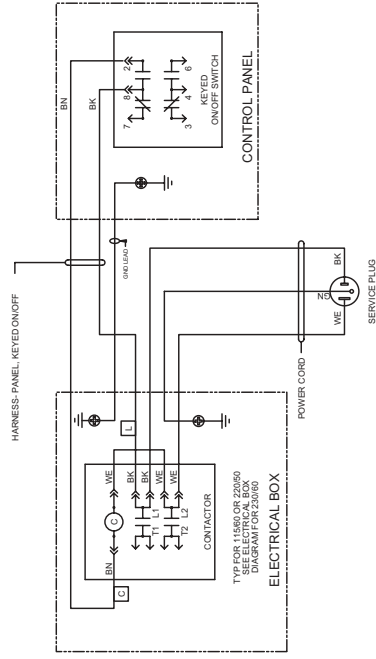

OPTION #1- KEYED ON/OFF SWITCH *GR-01

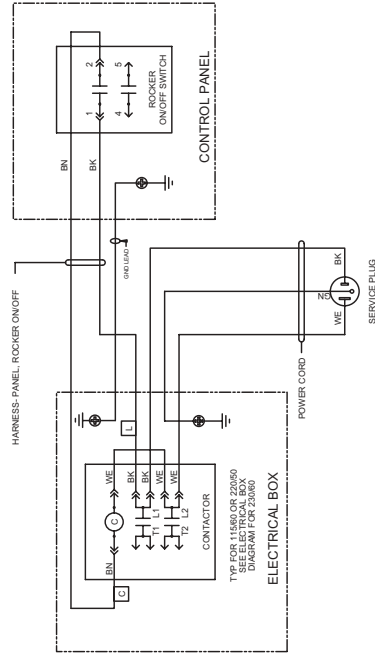

OPTION #2- ROCKER ON/OFF SWITCH *GR-03

OPTIONAL CONTROL PANEL MOUNTED LIGHT SWITCH

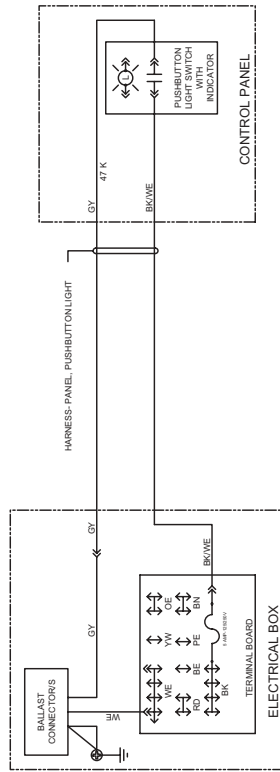

OPTION #1- PUSHBUTTON LIGHT SWITCH WITH INDICATOR *GR-02

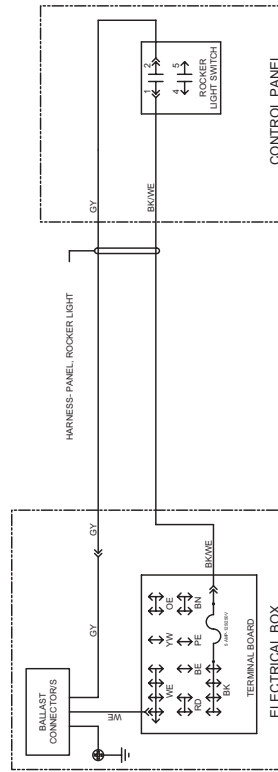

OPTION #2- ROCKER LIGHT SWITCH *GR-04

SECTION III

Maintenance

and

Repair

The manufacturer requires compliance to all CGC reclamation laws by saervice companies engaging in system processing.

WARNING

To avoid the possibility of an electrical shock, turn OFF the thermostat and unplug the power cord of the cabinet before cleaning or touching electrical connections or parts.

MAINTENANCE & REPAIR

PRE-SERVICE CHECK LIST

You may avoid the cost and inconvenience of an unnecessary product call by first reviewing this check list of the most frequently encountered situations that are not the result of defective workmanship or materials.

COMPRESSOR RUNS TOO MUCH

1. A refrigerated cabinet automatically compensates for product loading by running longer and more often. Before calling for service, check running time for at least one hour the first thing in the morning (before store traffic starts).
2. Be sure the doors seal. A faulty gasket seal will cause increased running time.
3. Check the room temperature. The warmer the room, the more the compressor will run.
4. Check the condenser to be sure the face is clean. Dirt and lint will raise pressures and increase running time. Use a brush or vacuum to clean the condenser.
5. Be sure condenser fan operates.
6. Check to see that evaporator fans are running.
7. If product is too hard (cold), try setting the Temperature Control (thermostat) warmer. This will result in warmer cabinet temperature and reduced running time.
8. Check insufficient ventilation to condenser.

CABINET DOES NOT OPERATE

1. Be sure cabinet is plugged in.
2. Check that breakers or fuses are good and all switches in the supply line are ON.
3. Be sure that cabinet Master Power Supply Switch is ON.
4. If you are in an area with voltage problems, try shutting off all non-essential electrical equipment.

LIGHT IS OFF

1. If the cabinet is operating, be sure the lamp is properly seated in sockets.
2. If cabinet is not running, check that Master Power Supply Switch and Light Switch are ON, fuses are okay, no switch in the supply is OFF, and that the cabinet is plugged in.

CUSTOMER COMPLAINT ON STORED PRODUCT

1. Check cleaning solutions used inside cabinet.
2. Check cleaning solutions, paint, or other contaminants used in store maintenance.
3. Sometimes the ingredients used in some products or containers will contaminate other products.
4. Be sure to follow a weekly schedule for cleaning cabinet interior.

SERVICE

In the event of a malfunction, damage to the cabinet, or if the cabinet requires service beyond the items in the "Pre-Service Checklist," contact your local service company or the dealer from whom the cabinet was purchased.

POWER FAILURE

Do not open the cabinet doors unnecessarily if power is cut off due to electrical failure. The cabinet will start up if the power supply returns, but will require sufficient time to reach maximum cold storage performance.

CABINET FAILURE

1. If the cabinet has stopped operating, check that the cabinet is securely plugged in and turned on. Contact a licensed electrician to locate and correct any power supply problems.
2. Do not open the cabinet doors unnecessarily.
3. Provisions for other storage of the product may be required to prevent spoilage.

If you call for service, describe your problem and give the following information to the service representative:

Cabinet Model No. _____

Part No. _____

Serial No. _____

(These numbers are located on a silver serial number rating plate in the upper left side of the cabinet interior.)

TOOLS:

To provide full service diagnostics and repairs on these cabinets, the following tools are needed:

A Multimeter

An Electronic Leak Detector

An Electronic Micron Gauge

A Vacuum Pump capable of pulling to 50 microns

Four Hand Valves

A Compound Gauge Set

A cylinder of nitrogen with a regulator capable of 10 to 400 pounds.

Standard refrigeration hand tools, e.g.: wrenches, tube cutter, swage and flare tools, wire strippers, wire crimpers, wire cutters, slot and phillips head screwdrivers.

PRODUCT HISTORY

The first rule in servicing a refrigeration system is to determine if the problem is an electrical or mechanical failure.

First, try to obtain the product's history of operation from the customer. This will help identify the source of the problem.

Good facts from the cabinet user can help identify whether the problem is electrical, within the refrigeration system, or a "misapplication by the user". Get the history of operation and failure by asking these questions:

- 1) Were there any brown-outs or power outages that they are aware of?
- 2) Is the cabinet on a dedicated circuit?
- 3) Has any other equipment in this area had operational problems?
- 4) When was the last time the cabinet's operation was confirmed as working properly?
- 5) When was a problem noticed?
- 6) How long has the equipment run without this problem? (Years? Weeks? Days? Hours?)
- 7) Was anything tried prior to your arrival?

The refrigeration system should only be entered if it is absolutely necessary. It is critical that a clean, uncontaminated system be maintained.

If a system is unable to reach the proper operating temperature, a test of the unit's mechanical refrigeration components is required.

COMPRESSOR EFFICIENCY TEST

To test the compressor, place compound gauge on the compressor's suction port.

While the compressor is running, close off the suction line so that only the port and valve are part of the compressor's low side.

When the valve is closed and vacuum has started, time how long it takes to pull the compressor's low side to its lowest possible vacuum.

Compressors used on these cabinets should be capable of pulling at least 20 to 22 inches of vacuum in less than 40 seconds.

Next, shut off the compressor and watch the gauge. A one or two inch rise in pressure is acceptable, since a small amount of freon may remain on the low side of the compressor, after which the reading should stabilize.

If the pressure continues to rise, the discharge reeds in the valve head have failed, allowing high pressure gas to return to the compressor.

If the compressor pulls less than 20 inches, the suction reeds have failed.

If the compressor takes longer than 40 seconds to pull to its ultimate low vacuum, one or both cylinders are not functioning as they should. Any reading less than these will require replacement of the compressor.

ENTERING THE SYSTEM

Entering the system should only be done as a last resort. Extreme care must be used no matter what the reason for entering the system. Of course there are times when it cannot be avoided, such as component or compressor replacement, or a leak within the system.

The system must also be entered any time you need to obtain the operating pressures. Again, use extreme caution to avoid any possible contamination.

Cabinets that use hermetic compressors typically do not have valve ports, so therefore process stubs for both suction and discharge sides of the system were added.

Line taps should only be used to obtain pressure readings, and not for the reprocessing of the system. The opening of a line tap is too restrictive for the pressure of vacuum procedures.

On a hermetic compressor system, once you have determined that reprocessing a system is required, recover refrigerant and remove the line taps.

Install hand valves at the process stub ends. Hand valves will be less restrictive to flow because of a larger opening. They will also be easier to use during repair procedures.

EVACUATION

Once the system has been cleaned and components have been replaced, you are ready to initiate the final servicing procedures necessary to achieve proper cabinet operation. Drier should be replaced prior to system processing.

Pull an evacuation to approximately 50 microns.

CHARGING

You should use a charging cylinder to measure in the correct amount of refrigerant. The charging methods are:

1. Add the refrigerant to the system until you reach a balanced pressure. This will give you an approximate static charge.

2. Weigh in the refrigerant using a scale calibrated in ounces.

The cabinet's operation is now ready to be tested. A final check of the refrigeration lines should be made before running the cabinet.

Be sure the refrigeration lines are not kinked or rubbing against each other.

Also check that the door seals properly. An air leak will affect proper operation, and the cabinet's ability to reach its coldest temperature.

Run the cabinet at both 100% run, and a cycling temperature for at least 24 hours. If the temperature and pressures are correct, the system can be considered repaired.

Hermetic systems should now have their process stubs pinched off, hand valves removed and the ends brazed shut.

COMPRESSOR INSTALLATION & MAINTENANCE

TO CHANGE THE COMPRESSOR:

1. Disconnect the power supply to the cabinet.
2. Disconnect the power supply leads at the compressor.
3. Disconnect wires to relay and capacitors.
4. Remove relay and starting capacitor and install on new compressor.
5. Remove defective compressor from condensing unit base.
6. Set new compressor in place.
7. Reconnect relay and capacitor wires.
8. Reconnect power supply lead.
9. Leak test, evacuate, and weigh in charge.

CHANGING DRIER

If flare connected, make sure flares and faces of fittings on new drier are clean and in good condition before installing new drier.

If sweat connected, clean tubing close to original drier before cutting tubing in clean area. Check that ends of the replacement drier are clean, then make brazed connection using as little heat as possible.

Cut tubing only with tube cutters, not hacksaws, to avoid metal filings from entering the system. Driers must be replaced any time you enter the system, except when you are obtaining pressures.

SERVICE VALVES

The compressors on some cabinets have service valves for measuring suction and discharge pressures. Two types are used. The first type is connected directly to the compressor body or shell and back seats to connect gauges to the access port. The second is on the end of a process tube and requires a gauge or charging line with a depressing pin to open valve when the connection is made.

CAUTION: This type valve should be tightly capped except when making the gauge connection.

TO CHECK FOR OPEN WINDINGS

Use a multimeter. Measure ohms between "C" and "R" and between "C" and "S."

If windings are O.K., multimeter will show a resistance reading between terminals.

If there is no reading, the compressor winding or windings are open and the compressor should be replaced.

TO CHECK FOR GROUNDED COMPRESSOR

Use multimeter. Touch probe from each terminal to an unpainted surface of compressor body. If there is no ground, there will be no change of the meter.

WARNING: Be Careful Not to Touch Uninsulated Parts of the Meter Probes

A reading indicates a ground and the compressor should be replaced.

If there is voltage at the compressor terminals and the compressor tries, but does not run, check voltage at the compressor terminals while attempting to start the compressor. If the voltage at the compressor terminals is below 90% of the nameplate voltage, it is possible the motor may not have developed sufficient torque to start. Check to determine if:

- A. Wire sizes are adequate.
- B. Electrical connections are tight.
- C. The circuit is not overloaded.
- D. The power supply is adequate.

A defective relay or capacitor may prevent the compressor starting.

TO CHECK OUT THE RELAY

1. Disconnect the cabinet from the power supply.
2. Remove the wires from the relay.
3. Touch probes to the contact terminals. Meter should show infinity if closed.
4. Touch probes to the terminals of coil. The meter should show a resistance reading.

If items 3 and 4 are O.K., the relay is good. If items 3 and 4 are not as indicated, change the relay.

TO CHECK CAPACITORS

1. Disconnect the cabinet from the power supply.
2. Make sure the capacitors are discharged before touching terminal. (Shunt across the terminal of capacitor with a heavy insulated wire.)
3. Remove the wires from the capacitors.
4. Any capacitor found to be bulging, leaking, or damaged should be replaced.
5. Use a multimeter to check the **run and start** capacitors for shorts or open circuits.

With a good capacitor, the indicator should first move to a reading and then gradually increase to infinity.

If there is no reading change, an open circuit is indicated.

If the multimeter remains on a low resistance reading, a short circuit is indicated.

On run capacitor, touch probes to metal case and each terminal. If meter show any reading, a ground is indicated. All defective capacitors should be replaced.

CLEANING & MAINTENANCE

CAUTION:

Make sure cabinet is disconnected from its power source prior to any cleaning or maintenance.

CLEANING THE CABINET EXTERIOR

Wipe the exterior occasionally with a cloth dampened in mild detergent water; rinse, and wipe dry with a soft, dry cloth. Do not use abrasive or caustic cleaners or scouring pads.

CLEANING THE CONDENSER - FIG. 1

1. Periodic cleaning of the condenser, located in the machinery compartment, can be easily accomplished by brushing the coils with a soft brush and/or using a vacuum cleaner with a brush attachment.
2. Be sure that dirt, dust, and collection of other debris do not build up to a point air circulation through the condenser is restricted.
3. Clean the condenser at least twice a year.

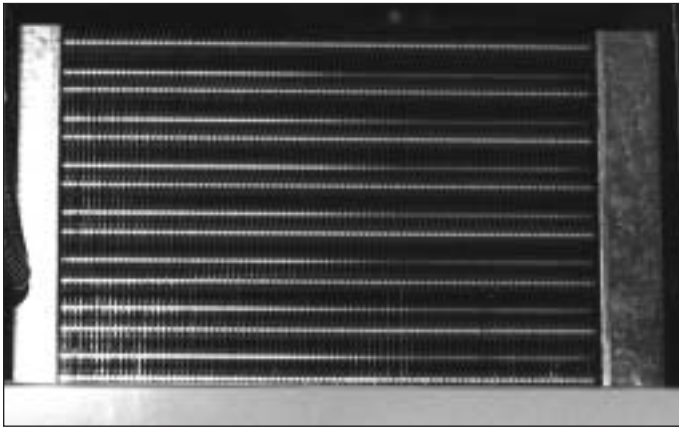

FIG. 1

CLEANING THE STORAGE COMPARTMENT

IMPORTANT: Do not use any objects or cleaners which may leave residues, odors, or particles. Avoid the use of strong chemicals or abrasive cleaners which may damage the interior surfaces and contaminate product within the storage area.

1. Remove product and store in another suitable cabinet, if possible. Be sure to prevent spoilage of the product which may occur if it is left at room temperature.
2. Turn OFF the Master Power Supply Switch.
3. Remove the shelving.
4. Wash the inside surface of the doors and the entire interior storage area with warm water and baking soda solution—about a tablespoon of baking soda per quart of water. Rinse thoroughly with clear water and wipe dry. This procedure can also be used for cleaning the door gaskets.
5. Wash, rinse, and dry the shelving while it is outside of the cabinet, using the same procedure as described for the storage area.
6. Be sure to correctly reinstall the shelving, turn ON the Master Power Supply Switch, check the setting of the Temperature Control, and allow time for cooling of the storage area before storing product.

WARNING

To avoid the possibility of an electrical shock, turn OFF thermostat and unplug the electric cord of the cabinet before cleaning or touching electrical connections or parts.

BALLAST REPLACEMENT

The ballast is located in the machinery compartment (A), attached to the back of the electrical control box (B).

1. Disconnect the power to the cabinet.
2. Remove the front panel.
3. Remove the cover panel on the electrical wiring box.
4. Disconnect the leads to the ballast.
5. Replace the ballast with correct part.
6. Replace the electrical wiring box cover panel.
7. Replace the front panel.
8. Reconnect the power to the cabinet.



Figure 1

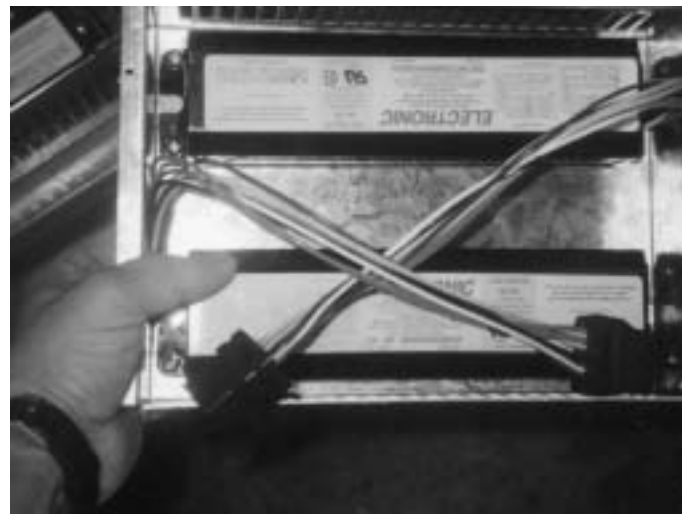
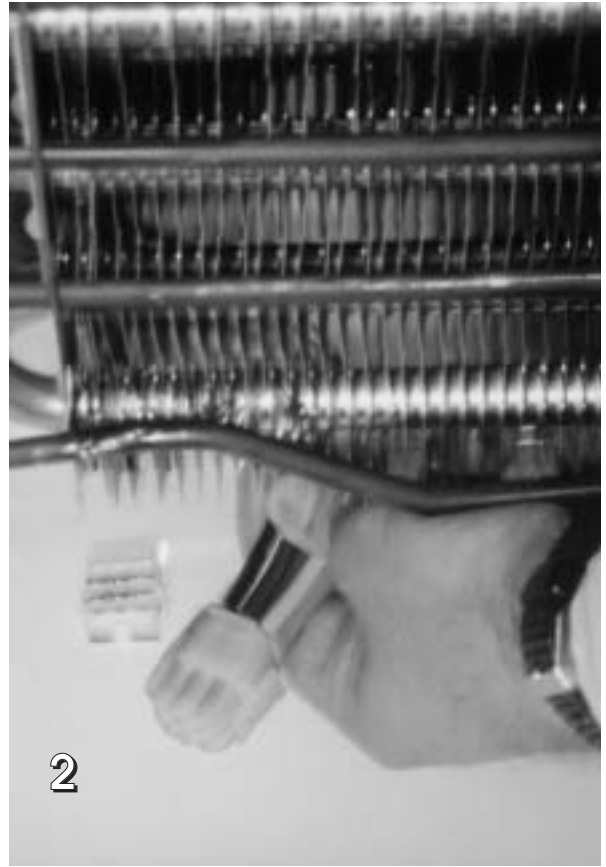
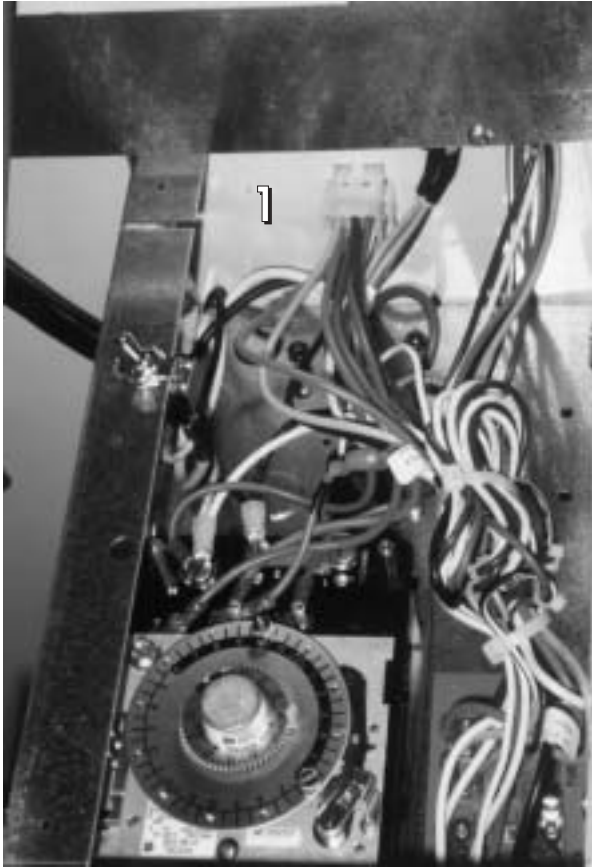

Figure 2

ELECTRICAL BOX / QUICK CONNECT

A nine pin wiring harness has been added to the upright models (med & low).

1. Electrical Box to cabinet
2. Main wiring harness to evaporator area.



CABINET RACEWAY / LOWER FRONT PANEL

Disconnect the power supply to the cabinet.

Access the raceway (top or bottom mount) by removing the front panels.

Remove the raceway cover.

1. Terminal board (power to mullion heater).
2. Heated door receptacle.
3. Door switch.
4. Fluorescent light harness.

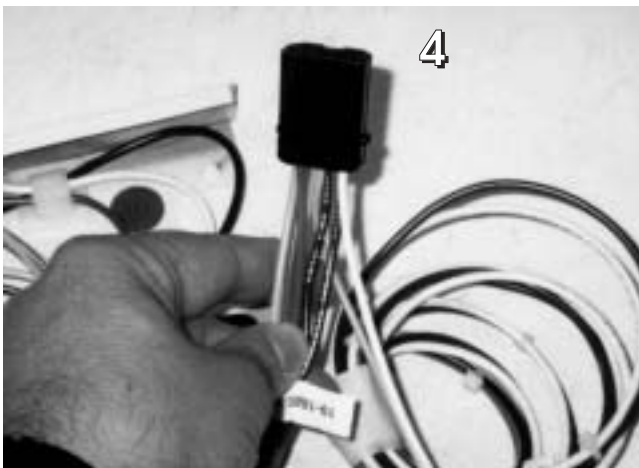
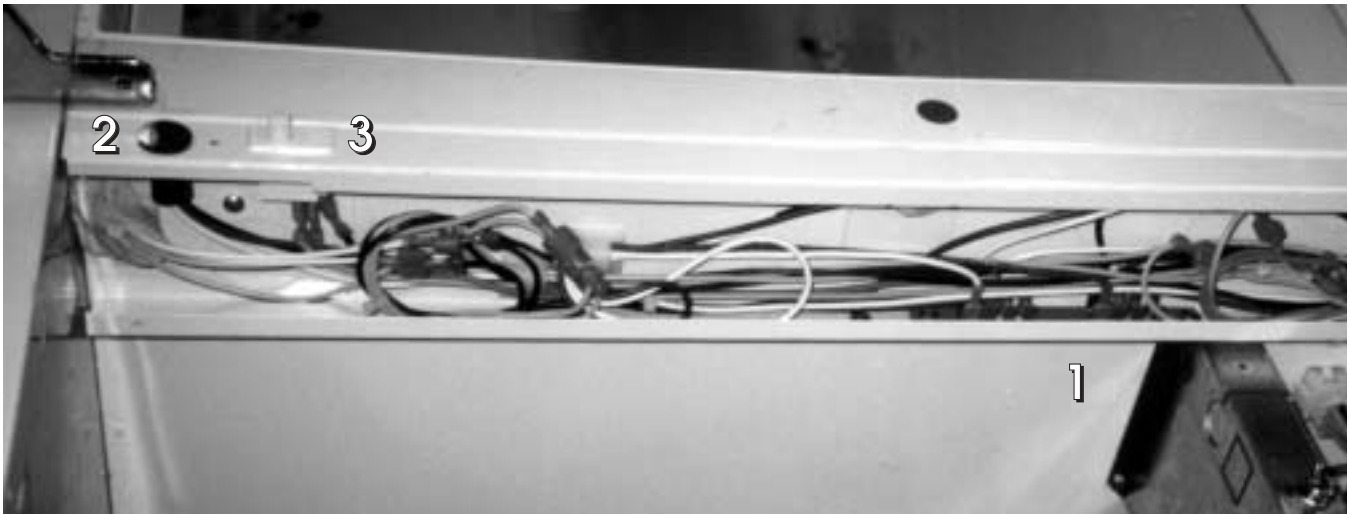

INSTRUCTIONS – SOLID DOOR REMOVAL, INSTALLATION & ADJUSTMENT

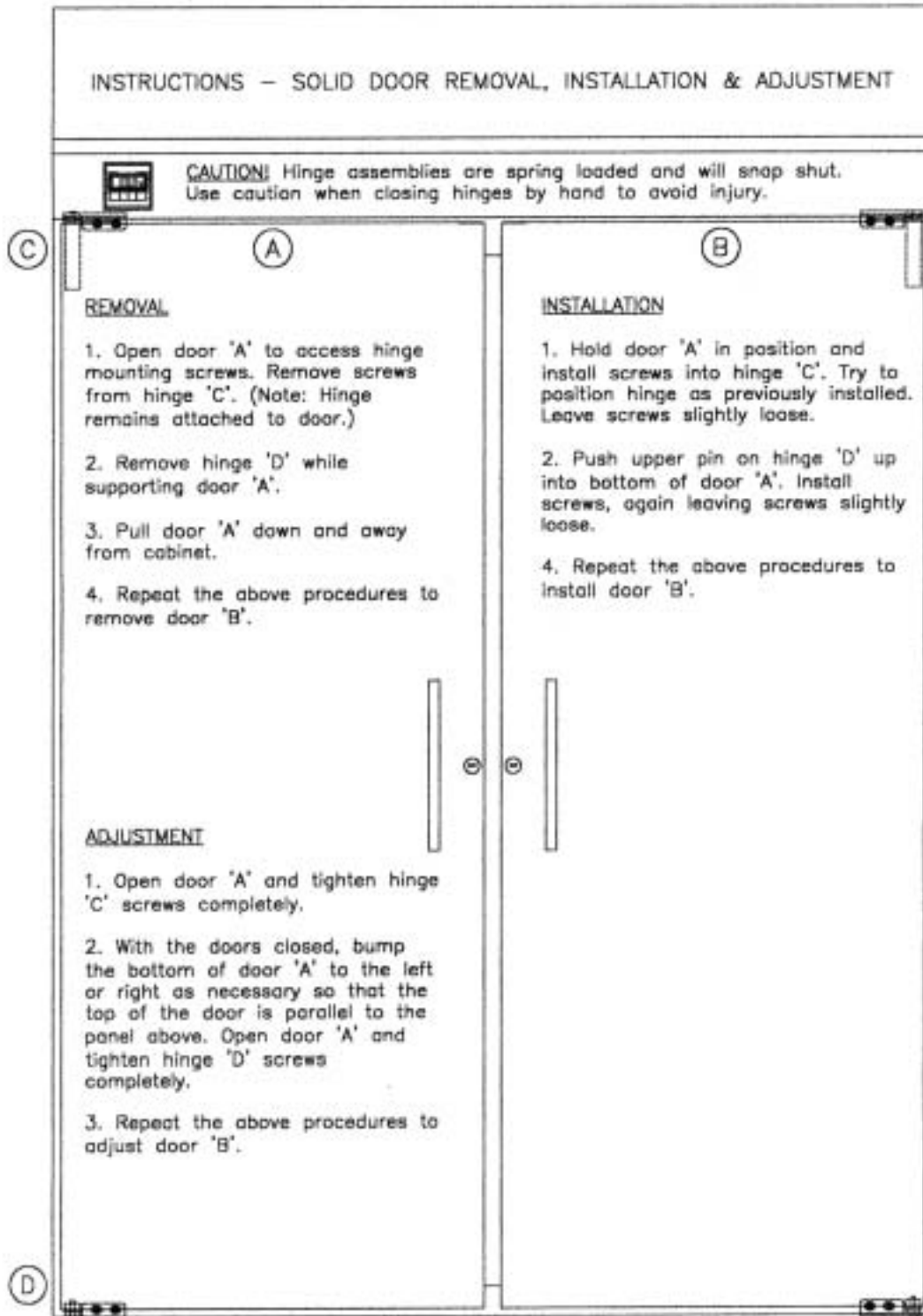

CAM HINGE DOORS – OPERATION & REMOVAL (Solid Door Cabinets Only)

HOLD-OPEN FEATURE

The doors can be opened up to a 95° angle and will maintain that position for loading or unloading the storage compartment. Refer to Fig. 1.

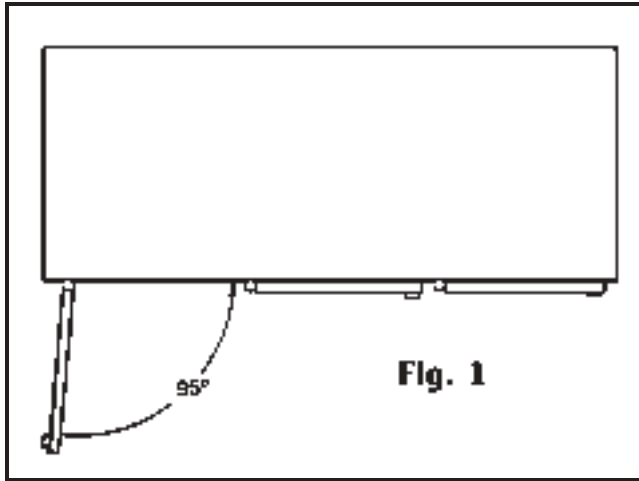

Door Removal

The door can be removed by opening door 180°. Grasp door with one hand. Remove two screws located in top bracket of door opening. Door can be lifted up and away from the BTM Bracket pin.

NOTE: Door closer cartridge is spring loaded.

ALIGNING THE DOORS

Proper alignment of the cabinet doors will eliminate hinge binding and provide correct gasket seal.

Top Bracket door opening slotted holes for up and down adjustment.

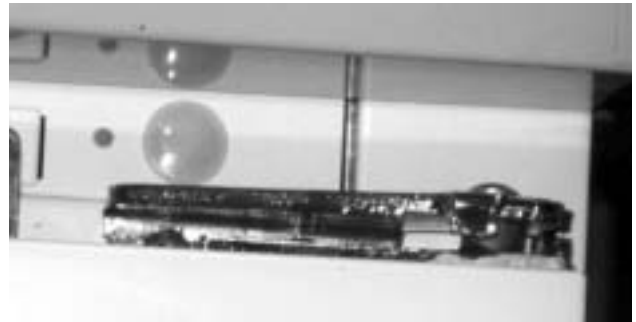

Spring Cartridge located in door, can be removed by two screws Top of Door.

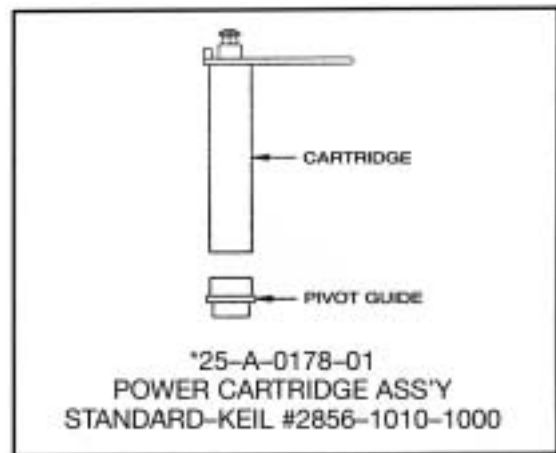

BTM Bracket Door opening slotted holes are for adjustment Left or Right



TORSION ROD HINGED DOORS - Maintenance & Removal

GLASS DOOR CABINETS ONLY

MAINTENANCE - ALIGNING DOORS

Proper alignment of the cabinet doors will eliminate hinge binding and provide correct gasket seal.

1. Check the level of the cabinet and door alignment by firmly closing each door. Observe the movement of the other doors. They should open slightly, then close and seal.
2. The hinge wings fastened to the cabinet door have slotted mounting holes for adjustment.
3. Additional adjustment can be made by adding shims between the hinge wing and either the door or the cabinet face.

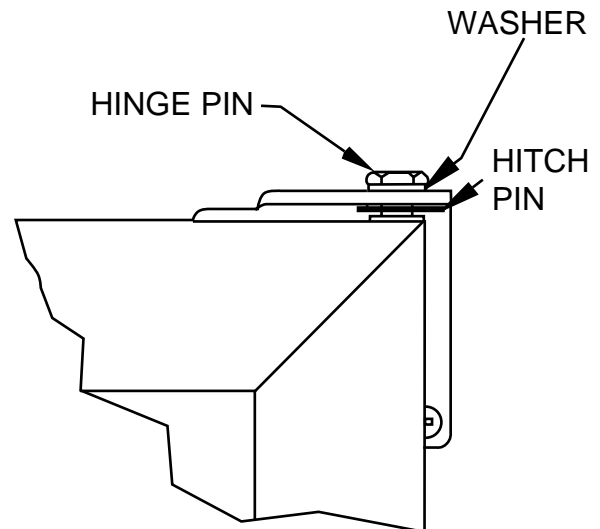

REMOVING DOORS:

1. Loosen lower hex nut (Nut "A") and release tension on the torsion rod.
2. Remove the hitch pin from the upper hinge pin.
3. Hold the door steady and unscrew the pin at top of the door. The door can now be lifted out of the lower hinge- bracket

REINSTALLING DOORS:

1. Set lower square shaft on door in lower hinge bracket
2. Insert top hinge pin and tighten to 12 ft./lbs. torque.

NOTE: Washer must be in place so top pin will not loosen and disconnect from door hinge.

3. Insert hitch pin through hole in upper hinge pin.
4. Run Nut "A" up snug. (You may have to loosen Nut "A" as you tighten tension as noted in Step 5.)
5. Set tension on door by turning square shaft in the direction the door closes. Set tension so that the door will self close when opened approximately 1". (Do not overtighten so door will slam.) Tighten Nut "A" so tension can be maintained.

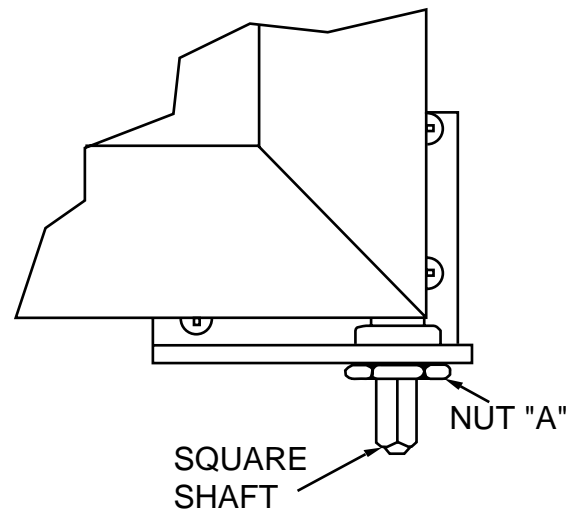

TORQUE ROD REMOVAL

1. Loosen nut "A" to remove door.
2. Attach vice grips to shaft.
3. Drive torque rod out of door.
4. Install new rod into keyway slot in door frame.
5. Reattach nut after installing door.
6. Turn shaft clockwise then lock nut "A".
7. Add torque until door will close by itself.

DOOR HANDLE & LOCK REPLACEMENT

SOLID DOOR

The door handle can be removed or replaced by removing the two chrome plug buttons in each end of the handle, "A".

The lock mechanism can be removed by drilling out the two pop rivets in the stainless steel cam cover – "B".

Access can be gained to the retainer clip which holds the lock barrel in place. The lock can now be removed.

GLASS DOOR

The door handle can be removed or replaced by pulling the door gasket out of its retaining groove just behind the door handle and inserting a philips head screwdriver into the recessed holes provided. Retainer screws hold the handle in place.

The lock mechanism is not replaceable on glass door models.

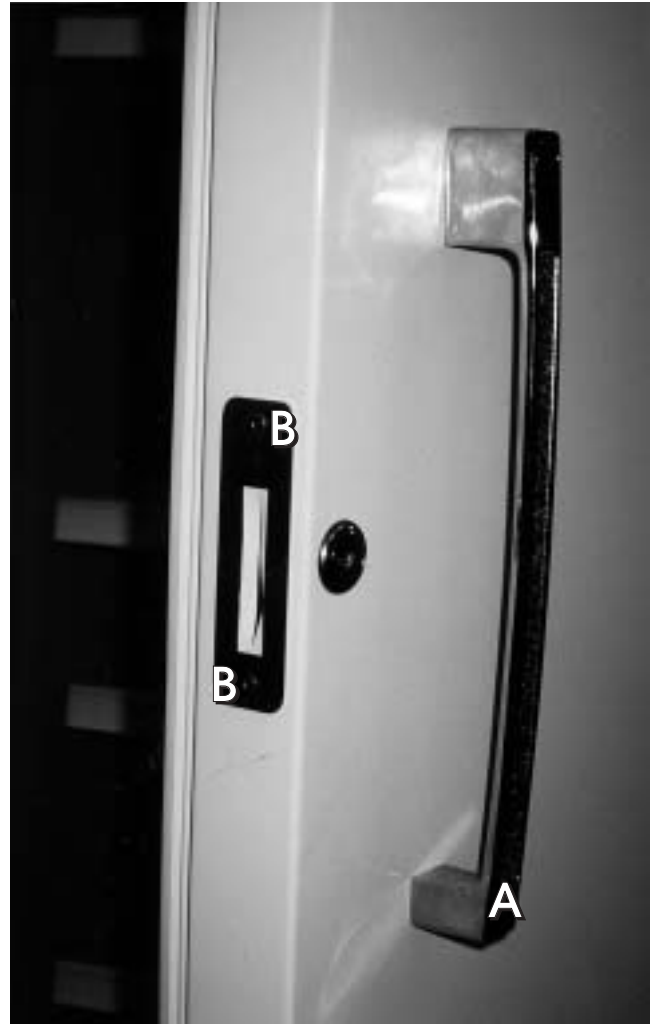

DOOR GASKET REPLACEMENT

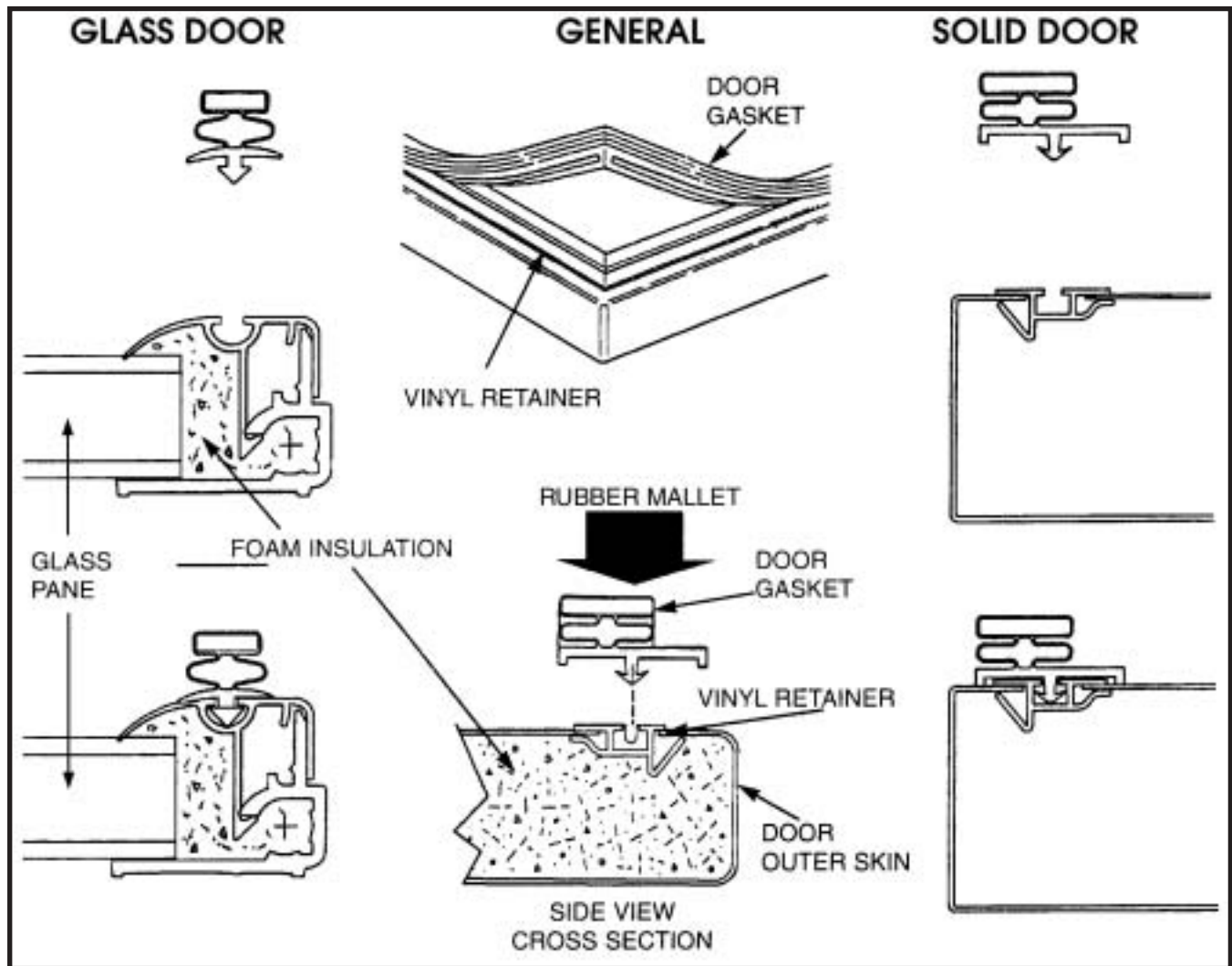

The gasket is replaceable on glass or solid door models. A retainer is molded into the door frame. The door gasket is then tapped into the retainer and secured for airtight door seal.

1. Remove door from cabinet.
2. Lay door front down on a flat, firm, nonscratch surface.
3. Pry up one corner of gasket with a putty knife or screwdriver. Pull gasket from perimeter of door retainer. Clean new gasket and straighten to insure proper fit.
4. Pull gasket from perimeter of door retainer.
5. Clean new gasket and straighten to insure proper fit.
6. Place gasket over retainer in door frame.
7. Using a rubber mallet, tap the gasket into the retainer. (NOTE: Gasket can be soaked in warm water to make pliable.)
8. Place door back onto cabinet.

CENTER MULLION HEATER REPLACEMENT

DISCONNECT POWER SUPPLY TO CABINET

Grip inner mullion cover panel at top while pulling on the inner mullion panel. Spread plastic extrusion apart at the top. Continue down the mullion assembly until mullion cover is free. Set aside.

Again spread plastic extrusion apart and carefully remove the insulation material. This will expose the mullion heater taped in place. Heater leads are routed either up or down (top mount or BTM mount) into an electrical raceway to a terminal board where they can be disconnected and replaced. Assemble in reverse order.

Note: reseal holes provided with a silicone sealant upon repair.



EVAPORATOR DRAIN PAN REPLACEMENT

The evaporator drain pan is located in the upper interior of the cabinet. It pivots down for ease of accessibility.

1. Disconnect the power to the cabinet
2. Release R.H. and L.H. Lock screws.
3. Drop the front of the pan and swing it back.
4. Disconnect the ground wire.
5. Raise the pan, unhook from back.
6. Remove the drain line from the drain hole.
7. Remove the pan from the cabinet.
8. Reconnect the power to the cabinet.

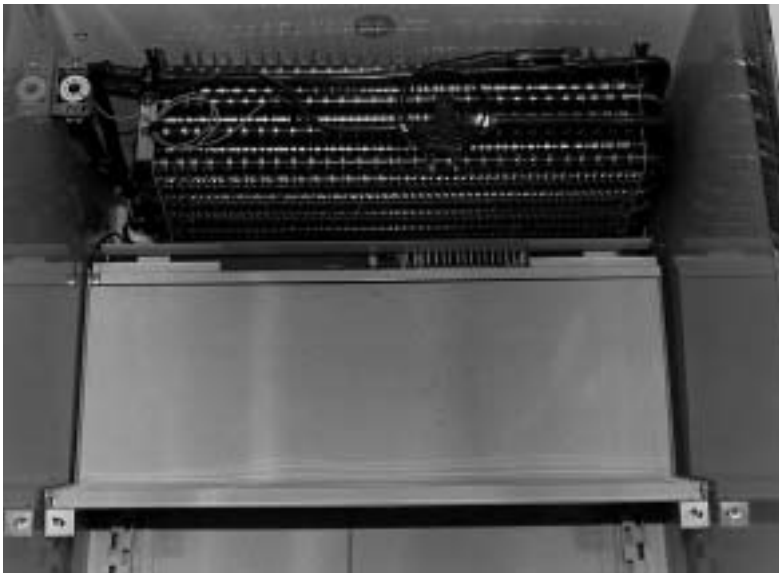

LIGHT SWITCH REPLACEMENT

On commercial models, the light switch is located inside the cabinet. It is on the light channel assembly.

On scientific cabinets, the light switch is located on the front control panel.

1. Disconnect the power to the cabinet.
2. Remove the plastic lamp shield. Remove the lamp bracket from the cabinet.
3. Remove the lock nut on the switch body.
4. Disconnect wire leads.
5. Connect new switch.
6. Replace the lock nut.
7. Replace the lamp shield.
8. Reconnect the power to the cabinet.



FLUORESCENT BULB REPLACEMENT



1. Remove the plastic outer lamp shield.
2. Grasp the bulb.
3. Raise the bulb up. Pull out of the socket.
4. Remove the lamp shields and the end caps.
5. Place a new bulb in the shield. Attach the end caps.
6. Insert the bulb into the cabinet, push up and snap into place.

TEMPERATURE CONTROL

The thermostat is located in the upper left hand corner of the drain pan area. It functions to control the temperature within the cavity of the cabinet. Rotate the thermostat clockwise for colder and counterclockwise for warmer.

NOTE: location of bulb well in coil.

1. Disconnect power to the cabinet.
2. Lower evaporator drain pan.
3. Remove screws on mounting bracket.
4. Slide thermal bulb assembly out of cabinet.
5. Replace thermostat into position as indicated in above photo.
6. Replace screws.
7. Replace evaporator drain pan.
8. Reconnect power to cabinet.

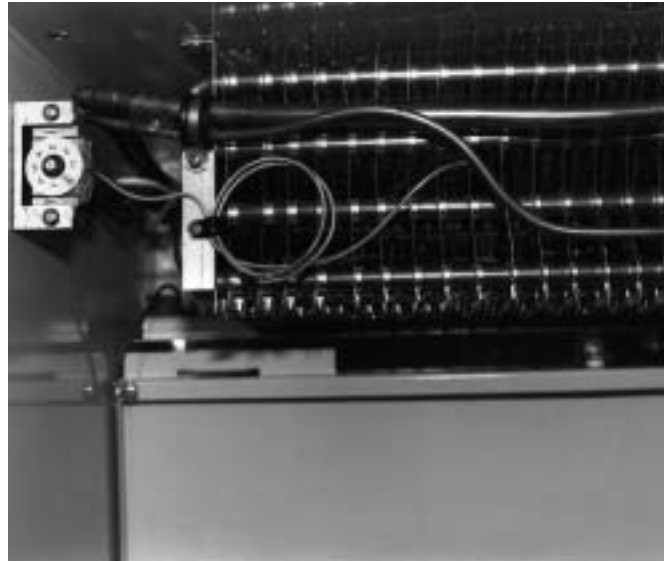

(Do not crimp capillary tube. This will affect thermostat's performance or make it inoperable.)

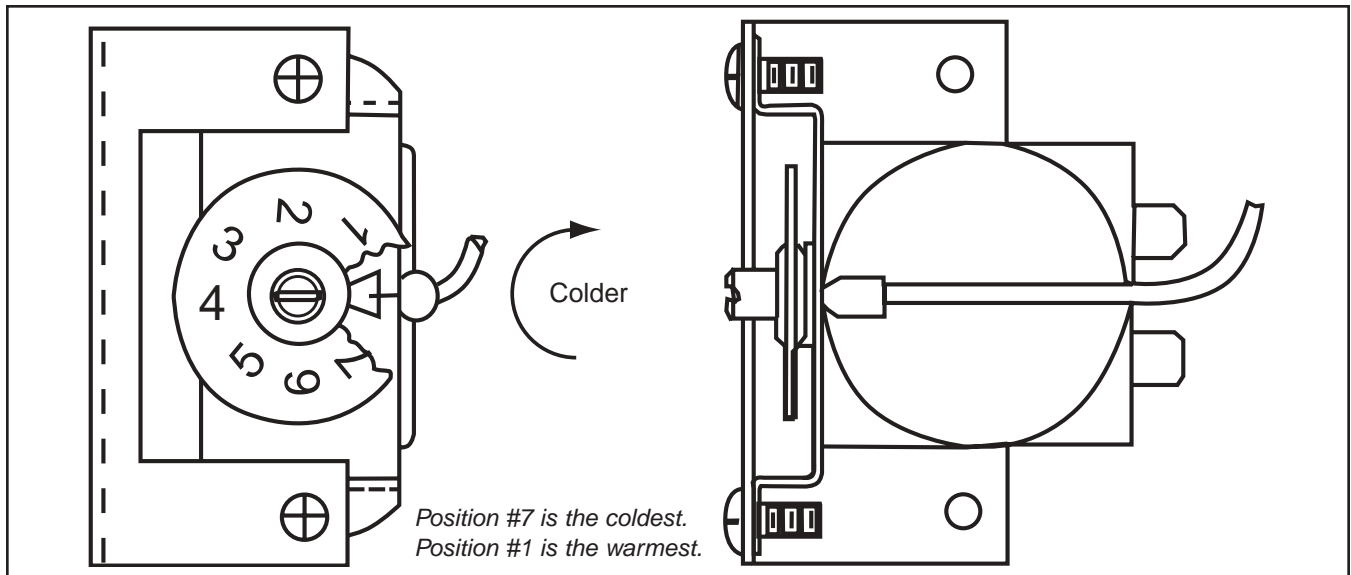

Temperature Range Adjustment

TEMPERATURE CONTROL

Flammable Material Storage & Chromatography Refrigerators

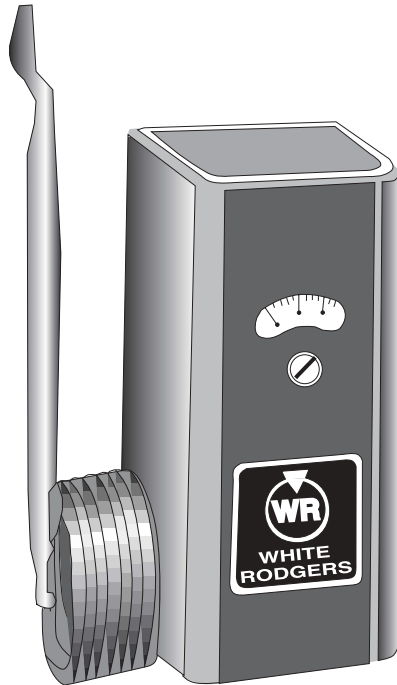

SPECIFICATIONS

FEATURES:

Temp. Range: -30°F / -34°C

Adjustable Differential

Type	Range °F (-34 to +32°C)	Diff. °F (2 to 22°C)	Capillary Length	Bulb Size	Switch Action	Full Elec. Rating	Motor Rating (Full Load)	
							120V AC	240V AC
1609-101	-30 to +90 (-34 to +32°C)	Adj. 3½ to 40 (2 to 22°C)	5 ft.	5¾" x 3/8"	Close on Rise	FGH	16A	8A

METERING DEVICE REPLACEMENT

The refrigerant metering device in this cabinet is expansion valve. It is a Sporlan FBV 1/4-C. It is located on the face of the evaporator coil behind the drain pan. (Super heat setting 6° to 8° valve is field adjustable.)

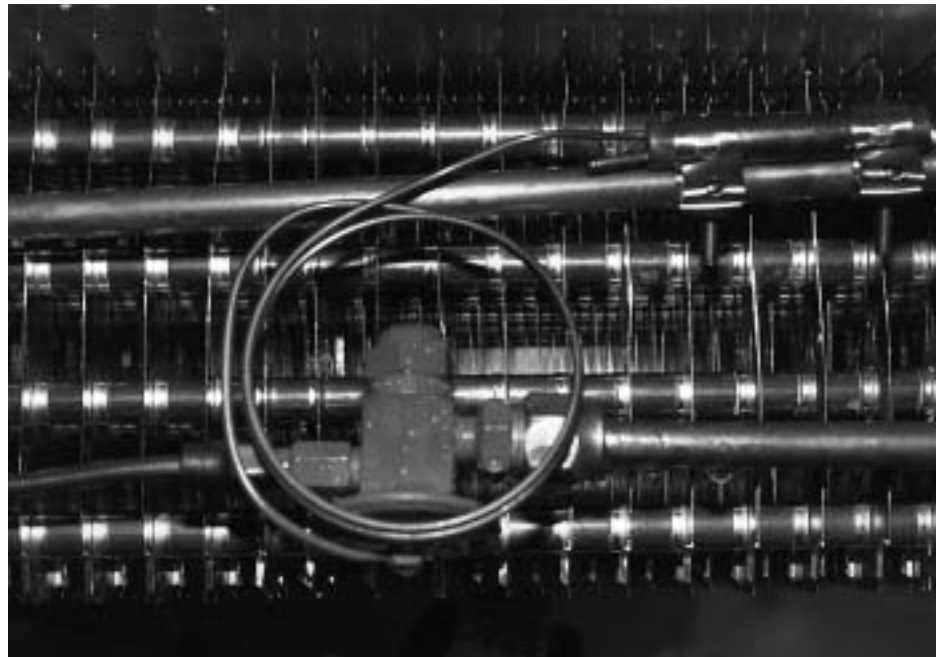
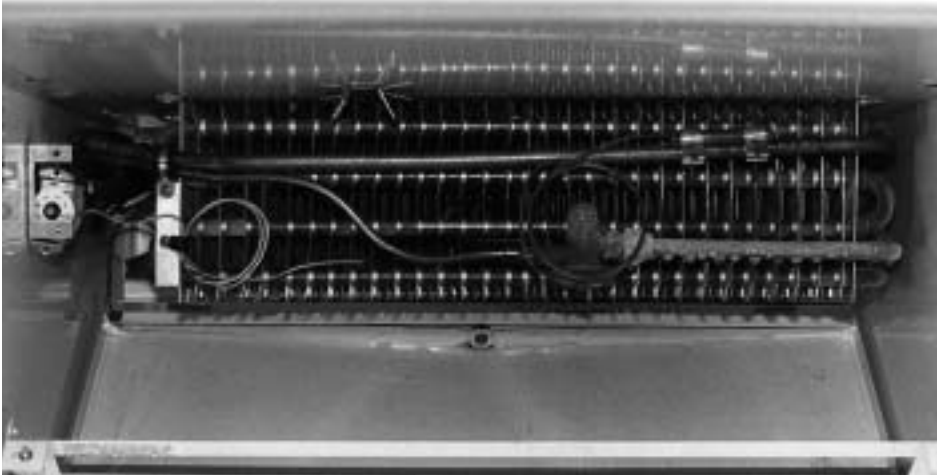

(Non-adjustable Shown)

1. Disconnect power to the cabinet.
2. Remove the evaporator drain pan.
3. Isolate the valve from the remainder of the system.
4. Remove the valve and replace with exact part number new valve.
5. Reposition the sensing bulb in original location.
6. Replace the drain pan.
7. Reconnect power to the cabinet.

EVAPORATOR FAN MOTOR REPLACEMENT (Rear Fan)



1. Disconnect the power to the cabinet and locate the evaporator fan in the cabinet interior behind the evaporator coil.
2. Remove the fan guard by rotating it counter clockwise to the position shown.
3. Remove the fan and bracket assembly by rotating it to the position shown.
4. Lower the fan assembly and remove the two screws that fasten the motor to the bracket.

Note: To assist the removal of the guard and bracket, press on the detent bumps to guide them out of the obround holes.

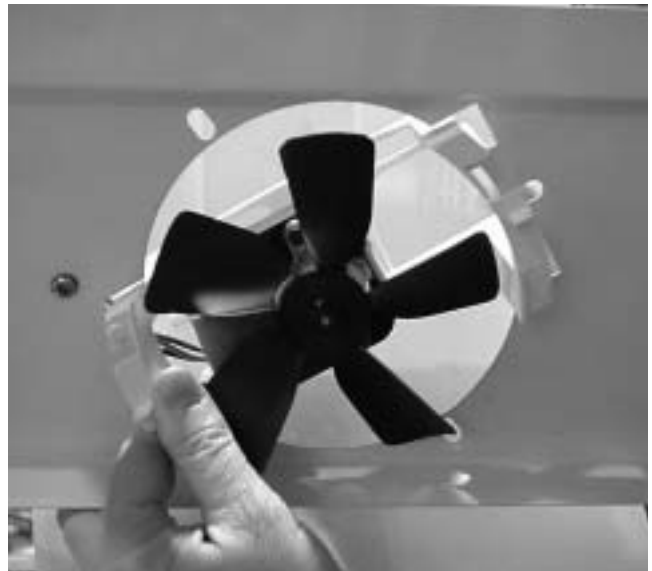
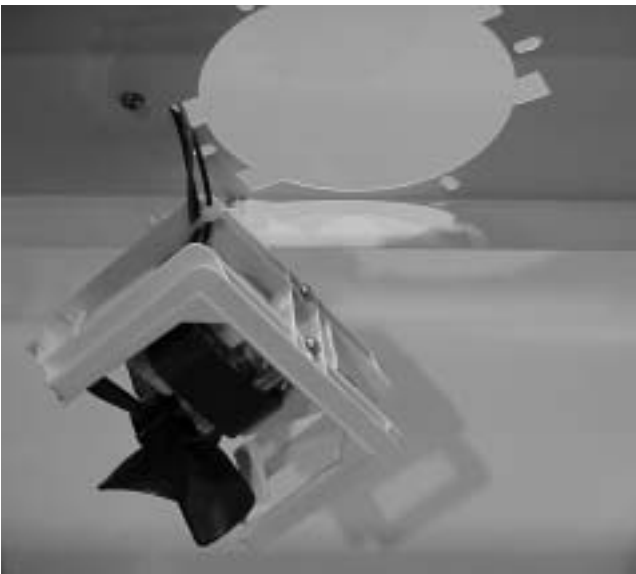

SHELVING / DRAWER Installation & Adjustment

To install shelves or drawers in a level position, insert the cantilever plate tabs into the rectangular holes in the desired position on the shelf standard. Lower the rear of the shelf so that the slots in the plate are completely down over the bottom of the holes.

NOTE: Supporting the front of the shelf with one hand while pushing down on the rear of the shelf will help ease installation.



To slope shelves, insert the cantilever plate tabs into the rectangular holes in the desired position on the shelf standard. Lift up on the rear of the shelf so that the top tab is locked behind the top of the rectangular hole. Hold the rear of the shelf up while lowering the front of the shelf until the bottom tab is inserted in the appropriate hole in the shelf standard.



CASTER INSTALLATION INSTRUCTIONS

ITEM	DESCRIPTION	QTY		
		1 DOOR 52-2022-00	2 DOOR 52-2023-00	3 DOOR 52-2024-00
5	CLAMP- SHORT	4	4	4
10	CLAMP- LONG	-	-	2
15	SKIRT	1	1	1
20	SCREW- #8 SELF TAP	2	2	2
25	CASTER CHANNEL ASSEMBLY (LH)	1	1	2
30	CASTER CHANNEL ASSEMBLY (RH)	1	1	1
45	SCREW- 5/16-18	4	4	6
55	NUT- 5/16-18	4	4	6
60	SCREW- #10 DRILL POINT	-	-	2

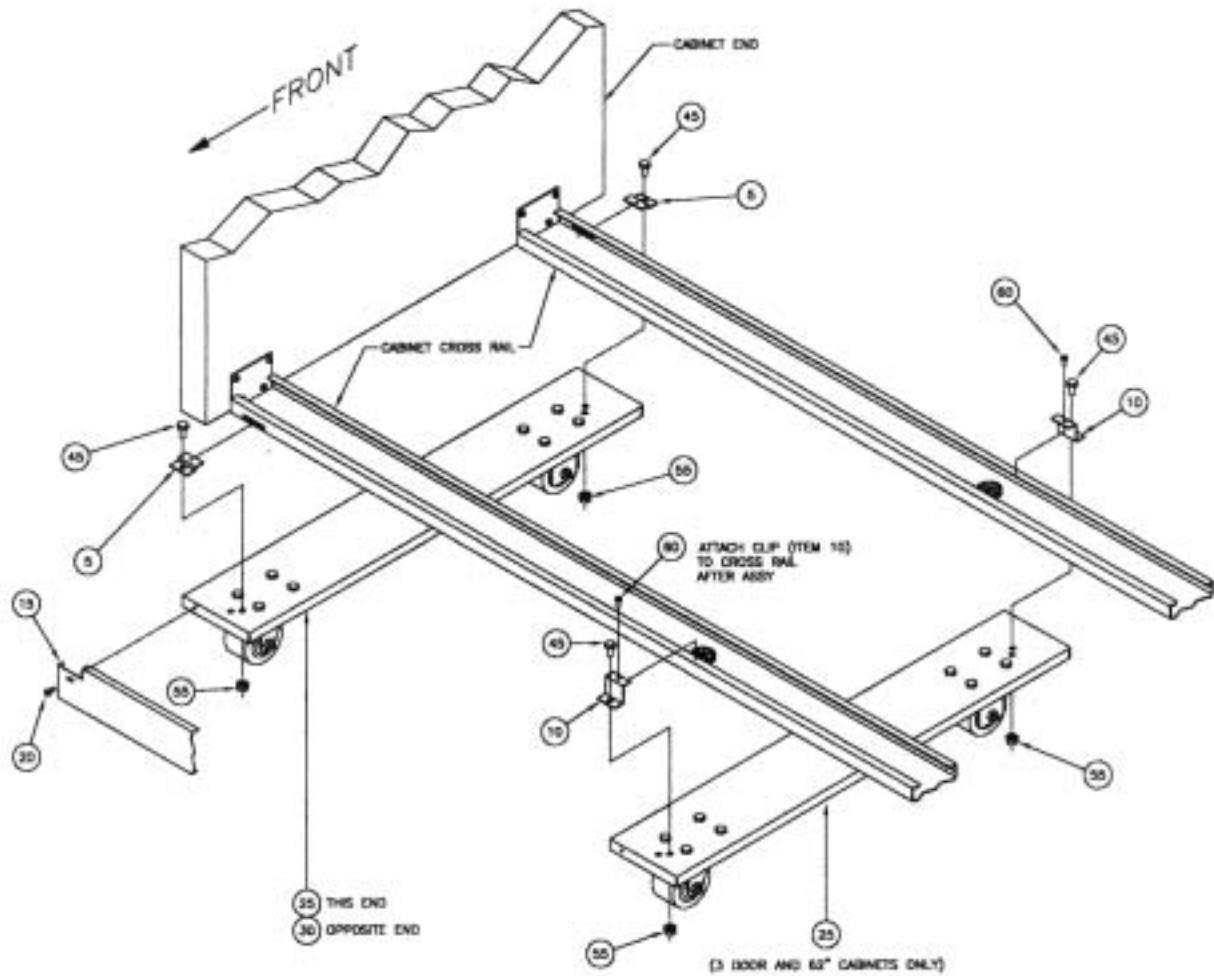

WARNING:

POWER SUPPLY CORD IS REQUIRED ON PERMANENTLY CONNECTED CABINETS WHEN CASTERS ARE INSTALLED. CONSULT THE NATIONAL ELECTRICAL CODE (NFPA 70) AS WELL AS STATE AND LOCAL REGULATIONS FOR FURTHER REQUIREMENTS.

ELECTRICAL & REFRIGERATION INFORMATION

BT30RF-FMS Flammable Material Storage Refrigerator/Freezer

To meet the requirements for storing flammable material, cabinet has no openings, other than the door, or any electrical components below the compressor compartment.

NOTE: Do not modify cabinet or remove label on the front which specifies storage limits.

PERFORMANCE CHARACTERISTICS: TEMPERATURE

Refrigerator: 4°C (38°F)

Freezer: -15°C (5°F)

ELECTRICAL & REFRIGERATION SPECS.

Medium Temp., Solid, 1-Door Refrigerators

BT30RF-FMS

SYSTEM COMPONENTS – R-404A

Compressor Model Number	Americold HP110-1-3083
Compressor BTUH / -10°F Evaporator	1013
Recommended Operating Temp. Range (F/C)	35°F to 50°F (2°C to 10°C)
Cabinet Volts	115
Expansion Device	Capillary .031 x 7"
Charge Refrig. Type / Oz. / Grams	R404A / 13 / 368.5

SYSTEM PERFORMANCE

AMBIENT	70°F / 21.1°C	80°F / 27°C	90°F / 32.5°C
Cavity Temp. (F/C)	37 / 2.7	42 / 5.5	44 / 6.6
Suction Pressure (PSIG / Kpa)	4.8 / 33	8.1 / 56	11.9 / 82
Discharge Pressure (PSIG / Kpa)	180 / 1241	227 / 1565	262 / 1806
Compressor Amps	1.2	1.2	1.3
Total Refrigeration Amps	1.2	1.3	1.4
Freezer Temp.	-3 / -19.5	-2 / -18.9	8 / -13

EVAPORATOR LAYOUT

This cabinet is of standard design with the exception of a freezer compartment located at the top interior of the cabinet - "A".

Depending on the application and number of door openings, this cabinet will need to be manually defrosted. A stainless steel pan has been provided to collect the water during a manual defrost.

TO DECONTAMINATE

Should more extensive cleaning and decontamination be necessary, the freezer door can be removed and the evaporator assembly pivoted down for complete access to the cabinet interior. The seam of silicone rubber sealant may also be removed and replaced if needed.



TO REMOVE FREEZER DOOR

1. Open freezer door and remove top thumbscrew securing hinge support bracket to the cabinet wall. Tilt bracket forward and lift door off hinge pin.
2. Remove second fastener and hinge support bracket.

TO TILT FREEZER EVAPORATOR ASSEMBLY DOWN

1. Pull tray and remove it from under freezer compartment.
2. Remove freezer door.
3. Remove thumbscrews, lower left and right front side of evaporator freezer interior.
4. Carefully swing down front edge of evaporator freezer assembly for full access to back of freezer and upper interior cabinet walls. Thermostat bulb may have to be disconnected.
5. Reverse process to reassemble.

NOTE: Door may be hard to open for a short period after closing. Wait a few seconds to allow interior air pressure to balance.

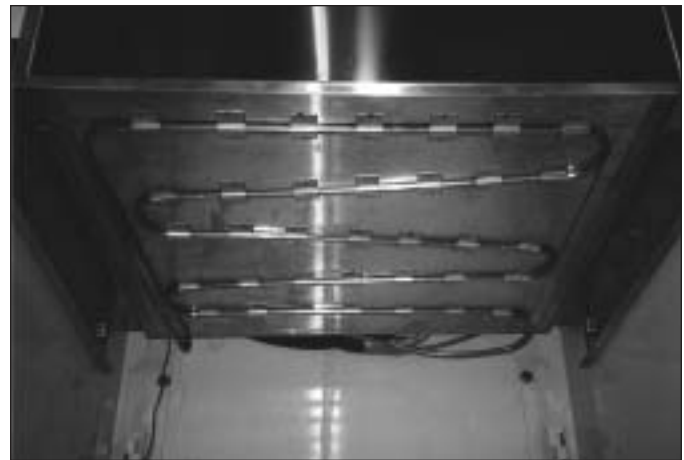

DEFROSTING AND CLEANING

To delay the need for a complete defrost, a plastic scraper may be used to scrape frost off of evaporator freezer surfaces.

However, a complete defrost will be required periodically. To defrost, perform the following:

1. Unload product from cabinet.
2. Turn master power supply switch to "OFF," and unplug power supply plug.
3. Collect defrost water in tray under evaporator freezer. A pan of warm water set in the freezer, or a fan blowing into it, will speed the process.
4. Wipe all freezer and drain tray surfaces clean. Let it dry.
5. Remove shelves and shelf standards if necessary to wipe down and dry refrigerator compartment.
6. Return all components; plug in power supply cord; turn master supply switch to "ON."
7. Once cabinet has attained desired temperature reload cabinet with product.

THERMOSTAT BULB LOCATION & SOLAR DIGITAL THERMOMETER OPT.

BT30RF-FMS

These bulbs are located at the rear left hand side of the freezer box.



The thermostat is mounted to the electrical box on the right hand side. The temperature is set in degrees Celsius (Figure 1).

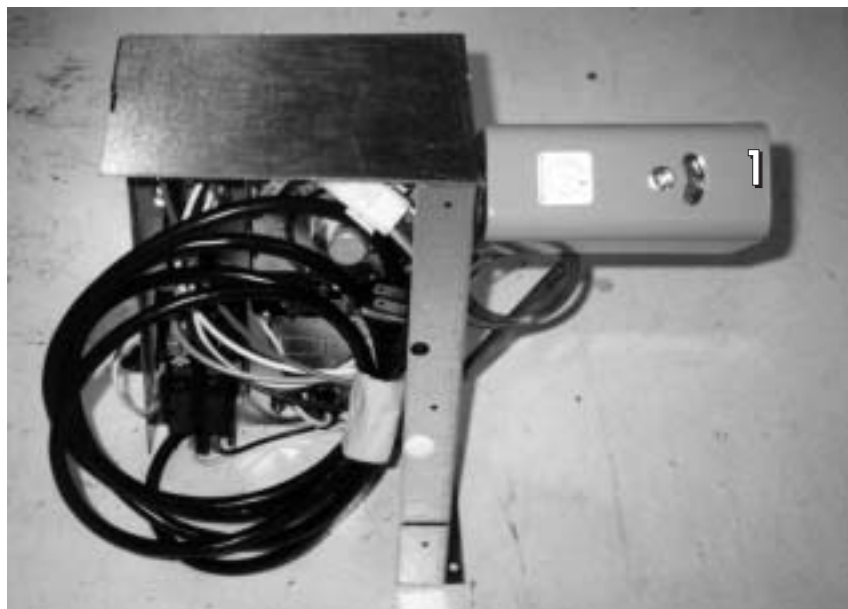

CONDENSING UNIT AREA

BT30RF-FMS

- 1. Compressor
- 2. Thermostat
- 3. Perimeter hot gas loop
- 4. Condenser coil
- 5. Strainer / Drier
- 6. Heat exchange



Rear View

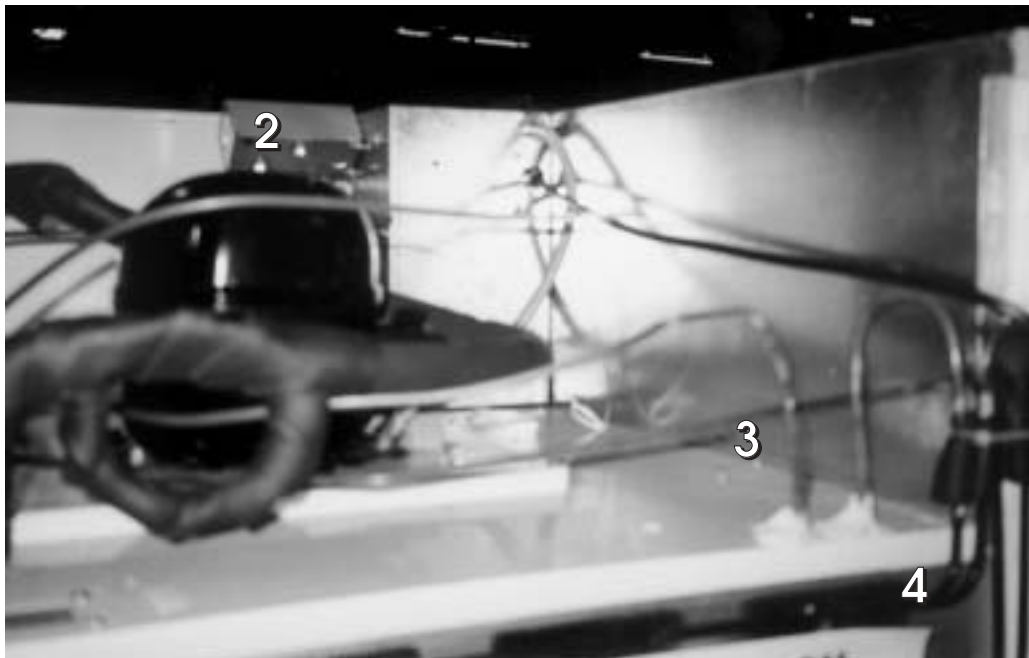

**ELECTRICAL &
REFRIGERATION
INFORMATION**

BT30RF-EXPR
Explosion Proof
Refrigerator/Freezer

EXPLOSION PROOF REFRIGERATOR/FREEZER BT30RF-EXPR

The model 525D is also UL listed for storing Flammable Materials. DO NOT MODIFY CABINET OR REMOVE LABEL ON THE FRONT WHICH SPECIFIES STORAGE LIMITS.

CONTAINER REQUIREMENTS

Refer to the latest edition of the following codes to determine correct container requirements and the definition of flammable or combustible liquids.

National Fire Protection Agency (NFPA) 45 Fire Protection for Laboratories using Chemicals.

National Fire Protection Agency (NFPA) 99 Health Care Facilities Chapter 7, Laboratories in Health-Related Institutions.

NFPA Address: Batterymarch Park
Quincy, MA 02269

You must follow these codes when storing flammable materials

The refrigerator/freezer complies with the following:

1. U.L. Listed, Commercial Refrigerator/Freezer for Hazardous Locations. Also Listed for Flammable Materials Storage. Control number 47R6.
2. For use in Class 1, Division 1, groups C and D Hazardous Locations. Operating Temperature Code, T4A.
3. Meets Requirements of OSHA 29CFR 1910.307.
4. Accepted for use: The City of New York
Department of Buildings
MEA 327-87-E

CAUTION: TO PREVENT IGNITION OF HAZARDOUS ATMOSPHERES, DISCONNECT THE PRODUCT FROM THE SUPPLY CIRCUIT BEFORE OPENING ELECTRICAL BOXES. KEEP ASSEMBLY TIGHTLY CLOSED WHEN IN OPERATION.

For Satisfactory Operation

1. The cabinet should be free standing with a minimum of 4" between the cabinet rear and the wall. To allow air flow over the compressor and machinery compartment, a minimum of 12" overhead clearance should be provided.
2. Level cabinet so door will slowly close when held open about 4" and released. This setting assures self closing if the door is closed hard enough to rebound open.

ELECTRICAL SUPPLY REQUIREMENTS

The electrical power supply must be installed according to the latest edition of the NATIONAL ELECTRICAL CODE – specifically Article 510 – Hazardous (Classified Locations - Specific). Appropriate materials and wiring methods must be used in order to comply with the current National Electrical Code for Class 1, Group I and D area installation. All local and other appropriate codes must be followed.

WARNING:

Be absolutely sure that the surrounding location has been checked for the absence of explosive concentrations before any electrical work is started.

Over current Protection: 15 amps. (If fuses are used use time delay type.)

GROUNDING

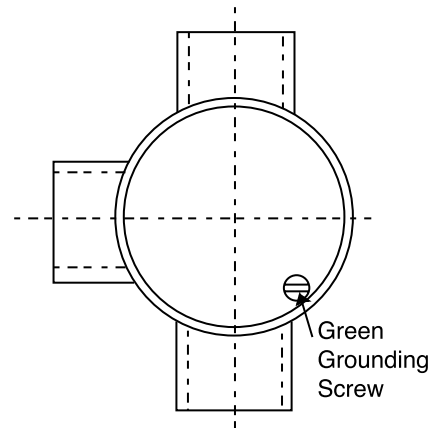

WARNING:

For personal safety, this cabinet must be properly GROUNDED. The ground wire to the cabinet must be installed on the green screw located in the conduit outlet box. (Refer to drawing.)

The conduit outlet box is where the incoming power wires are connected to the cabinet wires.

The incoming ground wire must be properly installed from the power supply. Consult a licensed electrician if you have any doubt about this wire being properly installed.

DEFROSTING & CLEANING

While scraping frost off of evaporator freezer surfaces with a plastic scraper will delay the need, a complete defrost will be required periodically. To defrost:

1. Unload cabinet of product.
2. Disconnect or turn off the power supply.
3. Collect defrost water in tray under evaporator freezer. Pans of warm water set in the freezer, or a fan blowing into it will speed the process.
4. Wipe all freezer and drain tray surfaces clean and dry.
5. Remove shelves and shelf standards if necessary, to wipe down and dry refrigerator compartment.
6. Return all components; connect power supply.
7. Once cabinet has attained desired temperature, reload cabinet with product. Intervals between defrosting will depend on product and number of door openings, humidity, ambient temperature, etc.

To Decontaminate

Should more extensive cleaning and decontamination be necessary, the freezer door can be removed and the evaporator assembly pivoted down for complete access to the cabinet interior. The seam of silicone rubber sealant may also be removed and replaced if needed.

To Remove Freezer Door

1. Open freezer door and remove top thumb screw securing hinge support bracket to cabinet wall. Tilt bracket forward and lift door off hinge pin.
2. Remove second fastener and hinge support bracket.

To Tilt Freezer Evaporator Assembly Down

1. Pull tray and remove it from under freezer compartment.
2. Remove freezer door.
3. Remove thumb screws, lower left and right front side of evaporator freezer interior.
4. Carefully, swing down front edge of evaporator freezer assembly, for full access to back of freezer and upper interior cabinet walls. Thermostat bulb may have to be disconnected.
5. Reverse process to reassemble.

ELECTRICAL/REFRIGERATION SPECS.

BT30RF-EXPR

Medium Temp., Solid, 1-Door Refrigerator/Freezer

SYSTEM COMPONENTS

Compressor	Tecumseh AE800AT-421-A4
Recommended Operating Temp. Range	35°F to 50°F (2°C to 10°C)
Cabinet Volts	115
Expansion Device	Capillary Tube - 8' x .036
Charge Refrig. Type / Oz. / Grams	R-134A / 10 / 283.5

SYSTEM PERFORMANCE

AMBIENT	70°F / 21.1°C	80°F / 27°C	90°F / 32.5°C
Cavity Temp. (F/C)	37 / 2.7	41 / 5°	40 / 4.5
Suction Pressure (PSIG / Kpa)	-3 / -21	3 / -21	1 / 7
Discharge Pressure (PSIG / Kpa)	107 / 738	126 / 869	144 / 993
Compressor Amps	2.1	2.2	2.4
Total Refrigeration Amps	2.4	2.4	2.4
Cabinet Pull Down	70° to 44° - Approx. 2 Hr.		

UNIT COMPARTMENT LAYOUT

BT30RF-EXPR

1. Compressor (Explosion Proof)
2. PTC Relay & Overload (sealed enclosure)
3. Thermostat
4. Thermostat Adjustment (enclosed)
5. Liquid Line Process Tube (high side)
6. Compressor Process Tube (high side)
7. Cold Wall Process Tube (low side)
8. Hot Gas Perimeter Loop
9. Condenser Inlet and Outlet
10. Capillary Tube Inlet

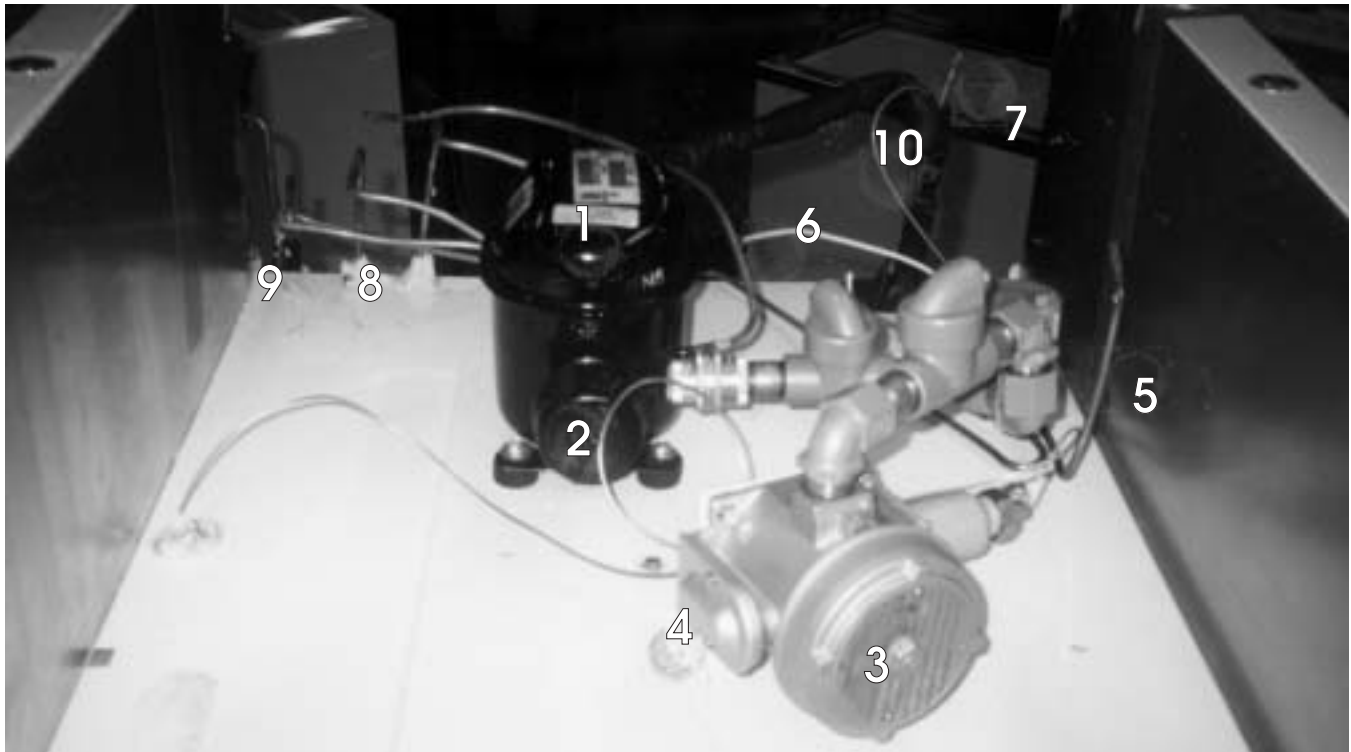

CABINET REAR VIEW

BT30RF-EXPR

The Condenser is attached to the rear of the cabinet via the hold down brackets as shown. The condenser consists of a 2-piece series circuit arrangement. It utilizes natural convection to dissipate heat generated by the refrigerant cycle. This condenser should be checked periodically and cleaned as necessary.



TEMPERATURE CONTROL

Located on the unit compartment, behind the front grill. The temperature setting may be changed by:

1. Remove the two screws that hold the cover in place;
2. Adjust the temperature control knob to desired cavity temperature. Replace cover.

The thermostat dial is calibrated in degrees Fahrenheit, but does not indicate temperatures inside the storage compartment. Typical performance for thermostat control settings is listed below. Cabinet thermostats are factory preset for 0°F.

Thermostat Setting	Freezer Temp.	Cavity Temp.
+20°	+11°F	51°
+10°	+12°F	41°
+5°	+10°F	41°

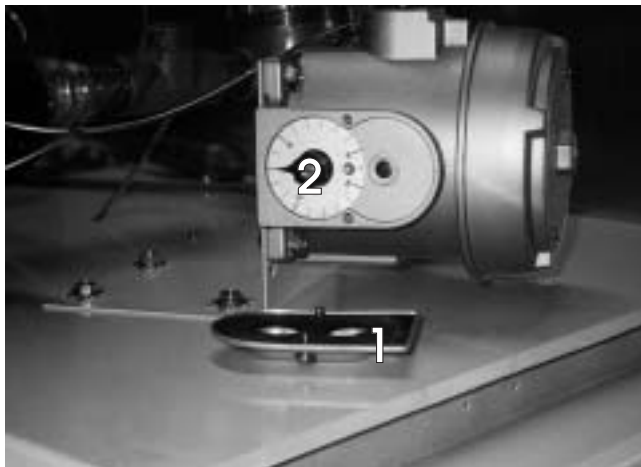

SWITCH HOUSING COVER REMOVED

IMPORTANT: Use only factory authorized replacement parts and procedures.

CAUTION: Always disconnect supply circuits before removing explosion proof cover.

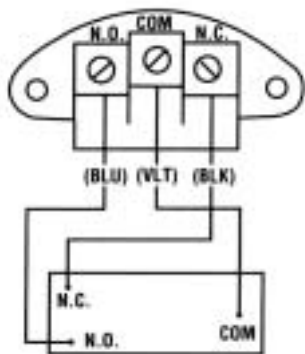

BT30RF-EXPR

REPLACEMENT OF SWITCHES

Types E121 & F120

1. Remove cover, (2) switch mounting screws, switch and insulator.
2. Disconnect (3) switch wires at switch terminal.
3. Install new switch and wire per **SET POINT ADJUSTMENTS**.
4. Mount switch and insulator inside enclosure and recalibrate per **SET POINT ADJUSTMENTS**.

SET POINT ADJUSTMENTS

NOTE: For set point adjustments and recalibration, connect control to a calibrated temperature source and stabilize unit.

TYPE E121

Adjust set point by turning external knob and pointer to desired setting on scale.

Recalibration—adjusting set point after replacing switch(es) and/or thermal assembly:

Slowly turn adjustment knob until switch transfers. Compare switch transfer point to actual temperature. If they do not agree, loosen set screws on adjustment knob and align pointer to indicate actual temperature.



THERMOSTAT BULB PLACEMENT

BT30RF-EXPR

The Thermostat Bulb is routed through a hole provided on the top, lefthand side of the unit compartment (1). The bulb is then inserted into a clamp located on

top of the stainless steel evaporator as shown in Figure 2.

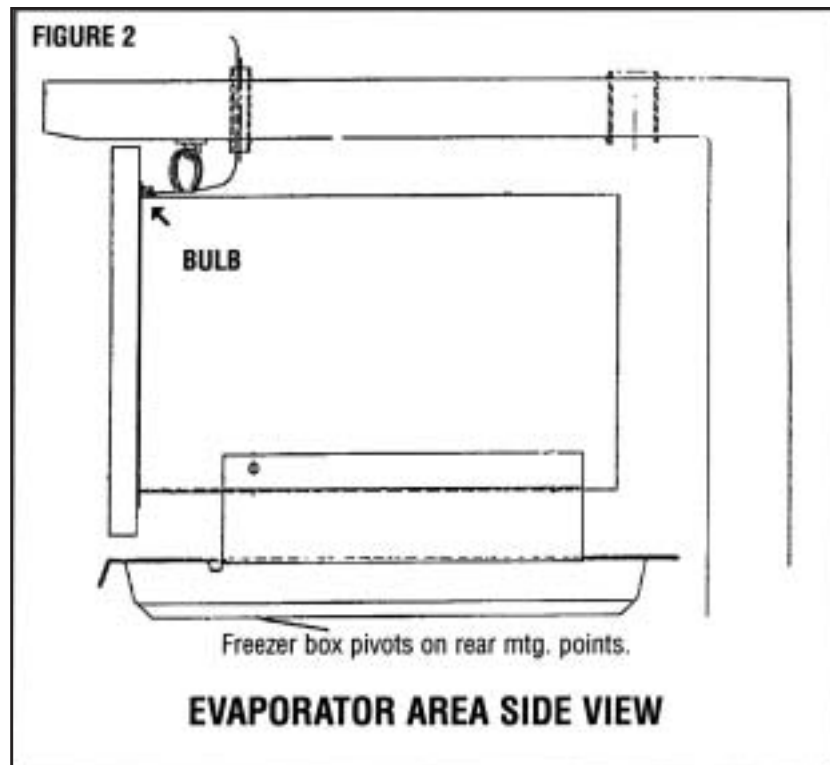
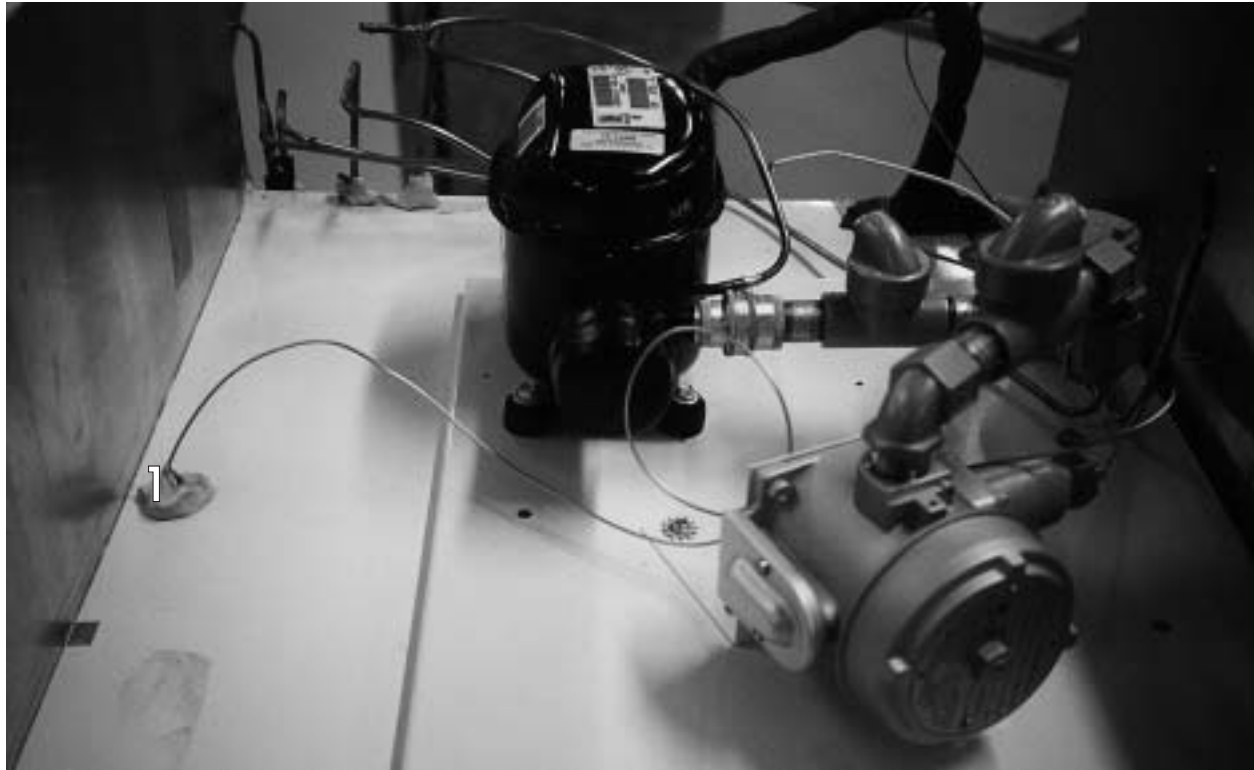

EVAPORATOR LAYOUT

BT30RF-EXPR

This cabinet is of standard design with the exception of a freezer compartment located at the top interior of the cabinet: "A". Refrigeration is accomplished by tubing being attached to the freezer compartment housing: "B".

Depending on the application and number of door openings, this cabinet will need to be manually defrosted. A stainless steel pan has been provided to collect the water during a manual defrost.

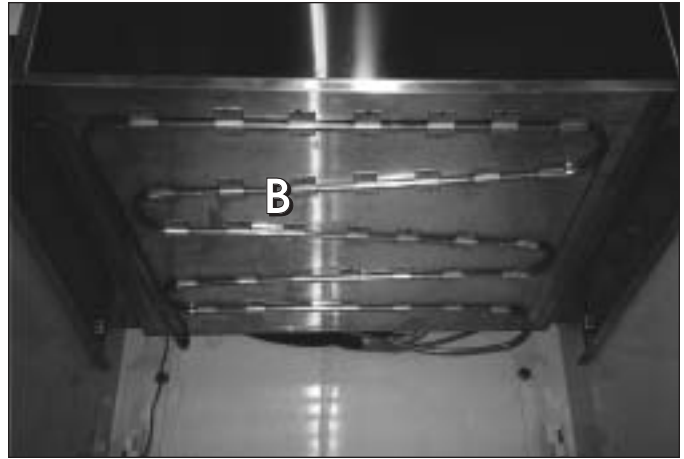

**USE COPPER CONDUCTORS ONLY
CABINET MUST BE GROUNDED**

**115V / 60 HZ. / 1PH
SUPPLY**

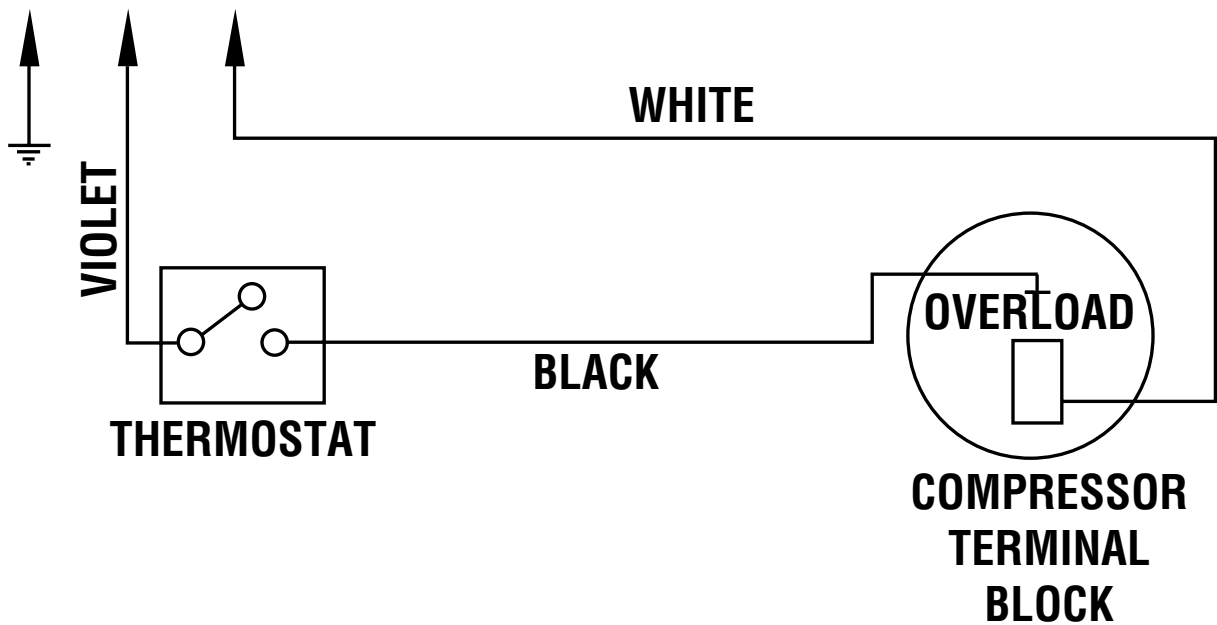

The electrical power supply must be installed according to the latest edition of the National Electrical Code - Article 510 - Hazardous (Classified) locations - specific appropriate materials and wiring methods must be used in order to comply with the current code for Class I, Group C and D area installation. All local and other appropriate codes must be followed. The installation must be made by a licensed professional electrician and contractor.

ELECTRICAL & REFRIGERATION INFORMATION

ST260RI

ST260RIR



MODULE #1 – DIGITAL DISPLAY

Blood Bank & Incubator Models

Vendor – Analogic Effective Through June, 2002

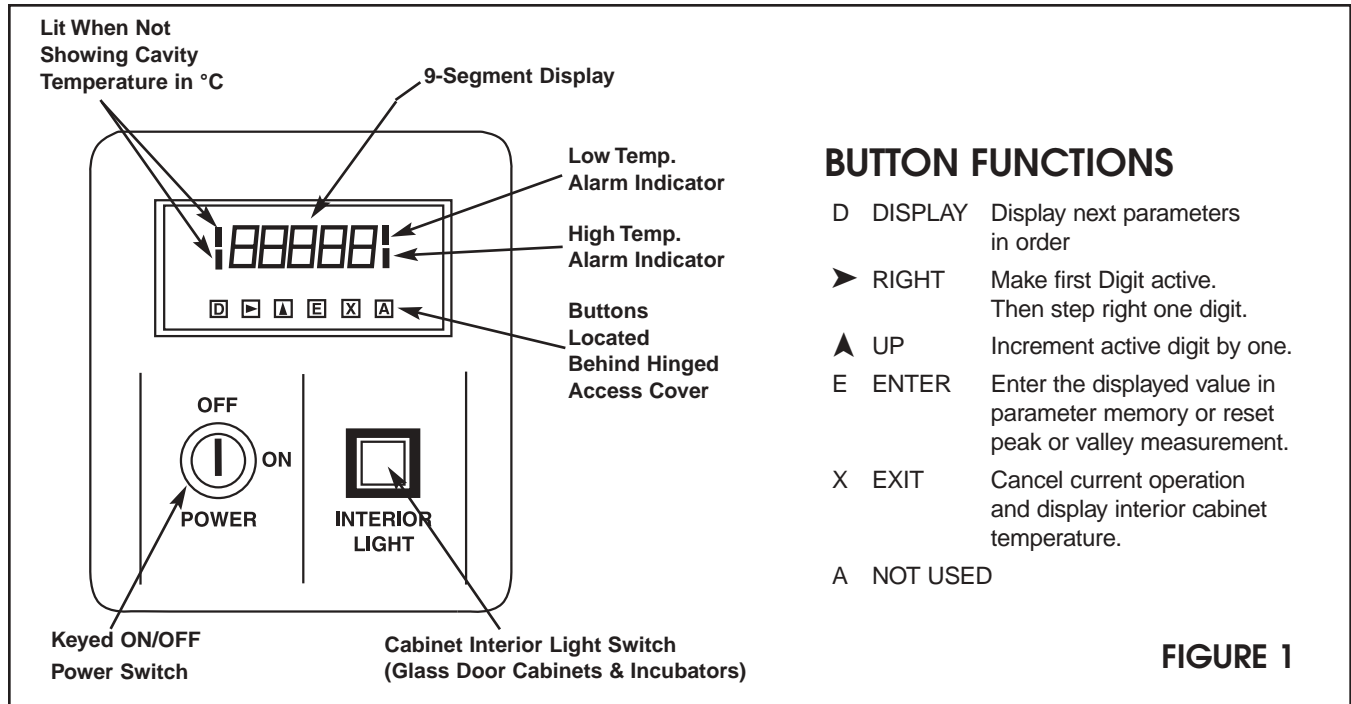

BUTTON FUNCTIONS

- D DISPLAY Display next parameters in order
- RIGHT Make first Digit active. Then step right one digit.
- ▲ UP Increment active digit by one.
- E ENTER Enter the displayed value in parameter memory or reset peak or valley measurement.
- X EXIT Cancel current operation and display interior cabinet temperature.
- A NOT USED

FIGURE 1

GENERAL

This module contains the ON/OFF power switch, interior cabinet light switch and digital meter displaying cavity temperature.

1. Cabinet power is controlled by a keyed ON/OFF switch. The key is removable in both positions. In the OFF position the battery charger and power failure relay in the optional Alarm System Module are still energized. **CAUTION - Risk of Electrical Shock. Disconnect Power Before Servicing.**
2. Interior cabinet light is controlled by a push button. In the recessed position, cabinet light is on and the switch will glow (on glass door cabinet and incubator only).
3. The digital process meter monitors cavity conditions. Cabinet temperature is displayed on a green vacuum fluorescent display in degrees centigrade (°C). Four red status indicators que the attendant of display mode and temperature alarm conditions. The maximum (peak) temperature and minimum (valley) temperature are saved for instant recall at a later time. The unit may be provided with alarm relay contacts for audio, visual and remote signaling from the optional Alarm System Module. Also a 420 mA process signal may be incorporated within the unit to drive an optional circular chart recorder.

SETTING & REVIEWING PARAMETERS

1. In normal mode of operation the instrument displays the current temperature reading. By pressing the 'D' key, other values and operating parameters may be sequentially reviewed. While the 'D' key is held down a code indicating the parameter is displayed; when the key is released, the parameter value is shown (See Table 1 for parameters). When these values are displayed, the two left side red indicator bars are lit, indicating a non-standard display (See Figure 1).
2. When the desired parameter value is displayed, press ➤ key to enter numeric entry mode. One digit will blink (for changing values only).
3. Press the ▲ key to adjust this digit to the desired value, then press ➤ to select the next digit.
4. When the right most digit is blinking and correct, press the 'E' key to store the value and return to normal meter operation.
5. If a mistake is made at any point before the 'E' key is pressed, press the 'X' key to cancel the operation and return to the default display.
6. The peak or valley values may be reset to the current display by pressing the 'E' key when the value is displayed.

MODULE #1 – ANALOGIC PARAMETERS

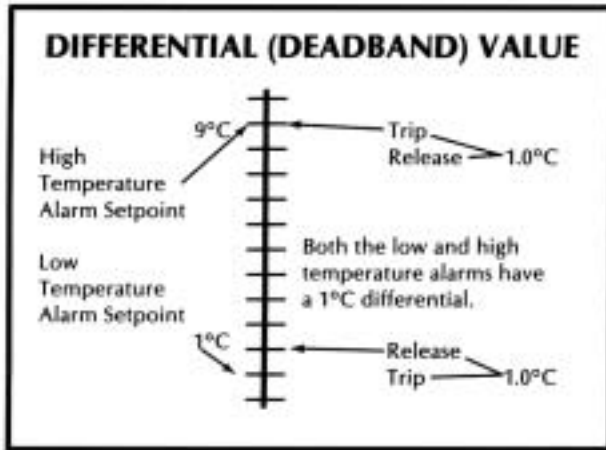

Factory Alarm Settings - TABLE 2

TYPE OF CABINET	LOW LIMIT ALARM	HIGH LIMIT ALARM
Lab Refrigerator	-1.0°C	9.0°C
Lab Freezer	-40.0°C	-10.0°C
Whole Blood Refrigerator	1.5°C	6.0°C
Plasma Freezer	-40.0°C	-19.0°C
Chromatography	-1.0°C	9.0°C
F.M.S. Refrigerator	-1.0°C	9.0°C
F.M.S. Freezer	-40.0°C	-10.0°C
Refrigerated Incubator	-15.0°C	50.0°C

Signal & Parameter List for Setting & Reviewing Values - TABLE 1

(Press & Hold 'D' Key) CODE	Two Left Side Red Indicator Bars	(Release 'D' Key) PARAMETER	Factory Setting	Parameter Value Range
I	ON	Cavity Temperature in Units of .1°F	—	For Viewing Only
P(Peak)	ON	Maximum Temperature Since Last Reset °C	—	Resetable Only
V(Valley)	ON	Minimum Temperature Since Last Reset °C	—	Resetable Only
S1	ON	Low Temperature Alarm Setpoint °C	*	-1999.9 to 7999.9
H1	ON	Differential (Deadband) for S1 °C	001.0	0 to 40.9
S2	ON	High Temperature Alarm Setpoint °C	*	-1999.9 to 7999.9
H2	ON	Differential (Deadband) for S2 °C	001.0	0 to 40.9
M	ON	DO NOT ADJUST	.5556	MUST BE AT
b	ON	DO NOT ADJUST	-017.7	FACTORY
AM	ON	DO NOT ADJUST	**	SETTING
Ab	ON	DO NOT ADJUST	**	ONLY
(none)	OFF	Standard Display (Normal Operation)	—	Current Temperature

* NOTE: See Table 2 for Factory Alarm Setting. ** NOTE: See Table 3 for Factory Parameter Setting.

Factory Parameter Settings - TABLE 3

CABINET TYPE	I	P	V	S1	H1	S2	H2	M	b	AM	Ab
LAB REFRIGERATOR	X	XX	XX	-1	1	9	1	0.5556	-17.7	29.63	-218.5
LAB FREEZER	X	XX	XX	-40	1	-10	1	0.5556	-17.7	19.75	1367.8
WHOLE BLOOD REF.	X	XX	XX	1.5	1	5.5	1	0.5556	-17.7	29.63	-281.5
PLASMA FREEZER	X	XX	XX	-40	1	-19C	1	0.5556	-17.7	19.75	1367.8
CHROMATOGRAPHY	X	XX	XX	-1	1	9	1	0.5556	-17.7	29.63	-281.5
F.M.S. REFRIGERATOR	X	XX	XX	-1	1	9	1	0.5556	-17.7	29.63	-281.5
F.M.S. FREEZER	X	XX	XX	-40	1	-10	1	0.5556	-17.7	19.75	1367.5
INCUBATOR	X	XX	XX	-15	1	50	1	0.5556	-17.7	13.68	331.5

DISPLAY INDICATIONS

Short or open in temperature sensor wiring



X-Exit key depressed; indicates cancellation of previous operation and return to standard display.

MODULE #1 – DIGITAL DISPLAY

Blood Bank & Incubator Models

Vendor – Daytronics Effective July, 2002 Through Present

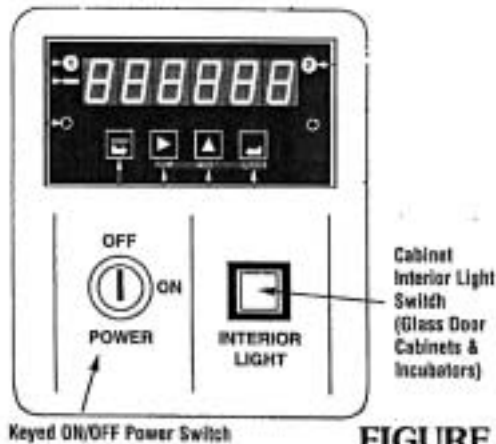

FIGURE 1

BUTTON FUNCTIONS

MENU

➤ **Menu:** This key changes the meter from **Operating Mode** to **Menu Mode** and steps through the various meter parameters that may be selected. These menu items may be “locked out” from front-panel selection by software and hardware.

▶ **Peak Display (Digit Select):** In the **Operating Mode**, pressing this key causes the peak value of the input signal to be displayed. Pressing the key again returns the display to the present “live” value.

In the **Menu Mode**, this key is used to select input type and decimal point, or to select one of the five display digits for programming. In the main menu, pressing the “PEAK” (Digit Select) Key causes the value or code that is stored for that menu item to be displayed, with the leftmost digit flashing. Each time the key is pressed, the next digit to the right will flash. The value of the currently flashing digit may be changed using the “RESET” (Value Select) Key.

In the **Alarm Mode**, pressing this key causes the most significant digit to the displayed *setpoint value* to flash. Digits are then selected for programming as in the Menu Mode.

▲ **Reset:** In the **Operating Mode**, holding this key depressed while pressing another front-panel key causes a specific “reset” to occur. Pressing the **MENU Key** while “RESET” is depressed resets all meter functions; pressing the **ALARMS Key** resets any alarm conditions; and pressing the **PEAK Key** resets the peak display to the present “live” data value.

In the **Menu Mode** or **Alarm Mode**, pressing the “RESET” (Value Select) Key sets the value of the currently flashing digit. Each time the key is pressed, the value increases by one. Holding the key down causes the digit to automatically step through the numbers.

↵ **Alarms (Reverse Menu):** In the **Operating Mode**, pressing this key displays the setpoint value of Alarm 1 and then Alarm 2. These values may be changed using the “PEAK” (Digit Select) and “RESET” (Value Select) Keys.

In the **Menu Mode**, pressing the “ALARMS” (Reverse Menu) Key steps the display backward through the parameter menu.

GENERAL

This module contains the ON/OFF power switch, interior cabinet light switch, and digital meter displaying cavity temperature.

1. Cabinet power is controlled by a keyed ON/OFF switch. The key is removable in both positions. In the OFF position the battery charger and power failure relay in the optional Alarm System Module are still energized. **CAUTION—Risk of Electrical Shock. Disconnect Power Before Servicing.**
2. Interior cabinet light is controlled by a push button. In the recessed position, cabinet light is on and the switch will glow (on glass door cabinet and incubator only).
3. The digital process meter monitors cavity conditions. Cabinet temperature is displayed on a red vacuum fluorescent display in degrees centigrade (°C). Four red status indicators queue the attendant of display mode and temperature alarm conditions. The maximum (peak) temperature and minimum (valley) temperature are saved for instant recall at a later time. The unit may be provided with alarm relay contacts for audio, visual, and remote signaling from the optional Alarm System Module. Also a 4-20 mA process signal may be incorporated within the unit to drive an optional circular chart recorder.

MODULE #1 – DAYTRONICS PARAMETERS

SETTING & REVIEWING PARAMETERS

1. In normal mode of operation the instrument displays the current temperature reading. By pressing the "→" key, other values and operating parameters may be sequentially reviewed. When the "→" key is held down, the code indicating the parameter is displayed. Next, by pressing the "▶" key once, the parameter value is displayed. (See Tables 1, 2, and 3 for parameters).
2. When the desired parameter value is displayed, press the "▶" key to enter numeric entry mode. One digit will blink (for changing values only).
3. Press the "▲" key to adjust this digit to the desired value. Then press the "▶" key to select the next digit.
4. When the right most digit is blinking and correct, press the "←" key to store the value and continue to the next parameter

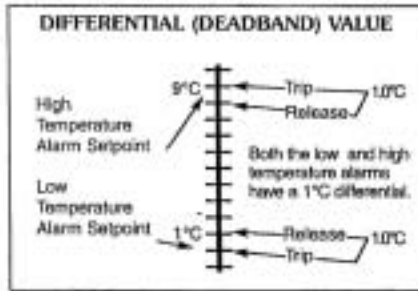

Factory Alarm Settings – TABLE 1

TYPE OF CABINET	High Limit Alarm (1)	Low Limit Alarm (2)
Lab Refrigerator	9.0°C	-1.0°C
Lab Freezer	-10.0°C	-40.0°C
Whole Blood Refrigerator	6.0°C	1.5°C
Plasma Freezer	-19.0°C	-40.0°C
Chromatography	9.0°C	-1.0°C
F.M.S. Refrigerator	9.0°C	-1.0°C
F.M.S. Freezer	-10.0°C	-40.0°C
Refrigerated Incubator	50.0°C	-15.0°C

TABLE 2	CHART RANGE	PARAMETERS	
		AN LO	AN HIGH
BASE MODEL REFRIGERATOR	-5°C to 25°C	-12.5°C	25°C
WHOLE BLOOD REFRIGERATOR	-5°C to 25°C	-12.5°C	25°C
BASE MODEL REFRIGERATOR	-45°C to 0°C	-56.3°C	0°C
BLOOD PLASMA FREEZER	-45°C to 0°C	-56.3°C	0°C
INCUBATOR	-15°C to 50°C	-31.3°C	50°C
ULTRA COLD	-0°C to 100°C	-25.0°C	100°C

TABLE 3

PARAMETER	VALUE
InPut	RTD (2d C)
SetuP	0000
ConFG	0000
FiLtr	1110
SCALE	1.000
OFFSt	0.0000
ALSet	00330
DeU1H	00000
DeU2H	00000
AnSEt	00
An Lo	See above
An Hi	See above

OPTIONAL ALARM SYSTEM

Visual Alarm Indicators

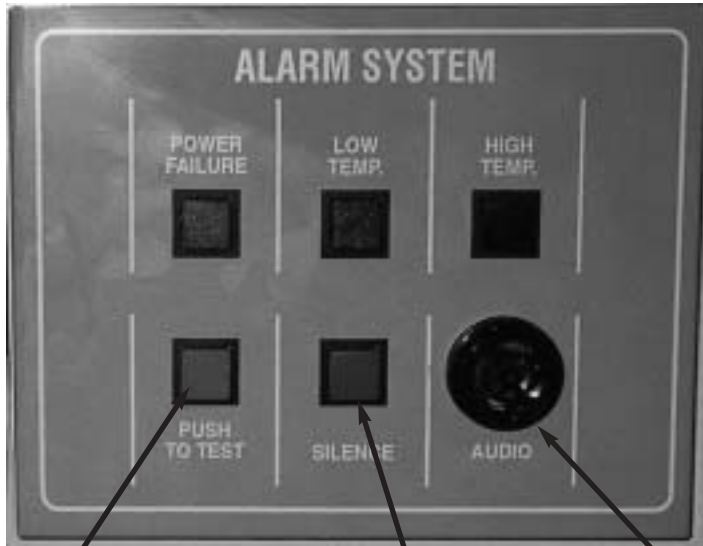

Alarm Circuit
Test Switch

Timed Audio
Silence Switch

Audio Alarm

FACTORY ALARM SETTINGS		
TYPE OF CABINET	LOW LIMIT ALARM	HIGH LIMIT ALARM
Lab Refrigerator	—	9°C
Lab Freezer	—	-10.0°C
Whole Blood Refrigerator	1.5°C	5.5°C
Plasma Freezer	-40.0°C	-19°C
Refrigerated Incubator	-15.0°C	50.0°C

TABLE 1

GENERAL

This module contains audio and visual alarm signals for power failure, low and high cavity temperature, plus a contact for remote alarm connection.

1. A power failure alarm is provided to que the attendant of interrupted electrical service. This alarm is only functional when the keyed ON/OFF power switch is in the ON position, and the battery is connected and properly charged. In a power failure condition all cabinet monitoring and operation ceases.
 - A. A rechargeable battery is provided external to the communicator panel, when the Alarm System Module is installed. Connect the red wire coded + to the positive battery terminal and the pink wire coded - to the negative. The battery is located in the compressor compartment.
 - B. Whenever the cabinet is plugged into an electrical supply the power failure relay and battery charger will be energized regardless of the keyed ON/OFF power switch position. This provides continuous charging of the battery. Caution should be used when servicing the cabinet.
CAUTION - Risk of Electrical Shock Disconnect Power Before Servicing Unit.
2. The temperature alarms indicate to the attendant that cavity conditions are in excess of either the predetermined low or high temperature limits. These cavity

temperature limit alarms are signalled from the Digital Display Module and set via the digital process meter. See Table 1 for factory settings. To adjust alarm points see "Setting and Reviewing Parameters" under MODULE # 1, DIGITAL DISPLAY.

3. A button is provided for testing proper alarm system signaling. When depressed the battery is exclusively used to power all visual alarm indicators, audio alarm circuit, and relay controlling the remote alarm contact. This test should be conducted daily to insure functionality and satisfactory battery charge. When testing alarms, visually check to see if lights from "Power Failure," "Low Temp.," and "High Temp." indicators come on when button is depressed. A burned out bulb in an indicator will disable that alarm function.
4. During an alarm situation, the audio portion of the alarm signal may be silenced by depressing the "SILENCE" button. If the alarm condition is not corrected within sixty minutes the audio signal will again be activated. This function has no effect on the visual signal or remote alarm contact.
5. A normally open alarm contact is provided on the reverse side of the communicator panel. It is intended for low voltage, N.E.C. Class II wiring only. Upon an alarm condition the contact closes until the problem, has been corrected.

ALARM SYSTEMS COMPONENTS

Rear Views of an Alarm Module

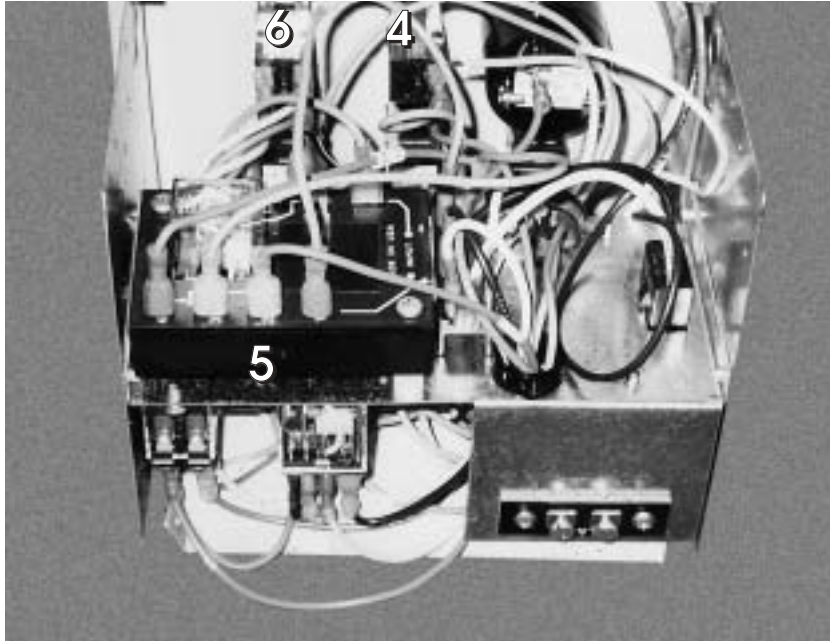

- 1 Battery Charger
- 2 6 Volt Relay
- 3 120 Volt Relay
- 4 Silence Indicator Light
- 5 Time Delay Relay
- 6 Test Switch
- 7 High Temp. Indicator
- 8 Low Temp Indicator
- 9 Power Failure
- 10 Remote Alarm Contacts

Emergency Procedure Planning:

Post adjacent to, or on the cabinet door, instructions to follow in the event of an alarm condition:

1. Persons to be notified and the telephone numbers of each;
2. The location of other refrigerator/freezers that might have the space for emergency storage;
3. The telephone numbers to call for electrical refrigeration system repair.

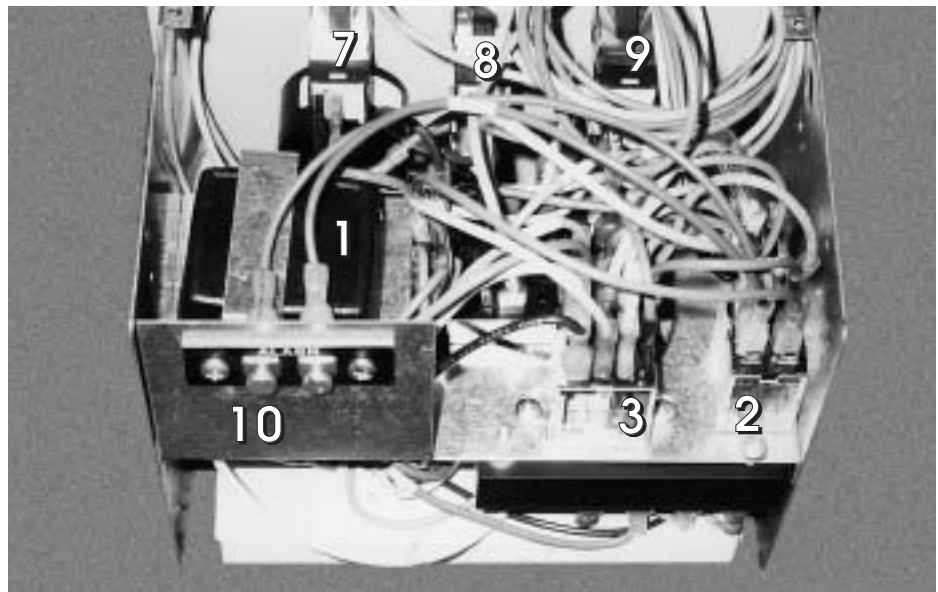

CAVITY TEMPERATURE CONTROL

Refrigerated Incubator

GENERAL

Incubator cabinets incorporate a proportional electronic temperature controller.



Cavity temperature is maintained by the electronic temperature controller located on the communicator panel. Set control knob pointer on desired cavity temperature. (See photo at left.)

Cavity temperature may fluctuate slightly with varying ambient temperature.

The photo below shows the rear view of the temperature control module. This module maintains cabinet temperature by pulsing voltage to a heater located under the evaporator coil. This module consists of a solid state controller, solid state relay and a potentiometer. When replacing the solid state relay, make sure the polarity between the controller and the relay coil are the same. When the cabinet has reached set point temperature, the load light indicator on the controller should be blinking on and off.



NOTE: If the cabinet temperature controller is set below 0°C manual defrost will be necessary.

MODULE #4 – DOOR AJAR/RECEPTACLE SWITCHES

Refrigerators

WHOLE BLOOD REFRIGERATORS – GENERAL

This type of refrigerator has a panel indicator to que the attendant of an open cabinet door. The temperature probe is located in a simulated product load within the cavity.

Whenever the cabinet door is open a panel indicator light is illuminated, when the door closes the light goes out.



FIGURE 1

INCUBATOR EVAPORATOR LAYOUT

- | | | | |
|---|--|---|--|
| 1 | Evaporator Coil | 4 | Heater Calrod
(800 Watts / 16.5 Ohms) |
| 2 | Cap Tube (14' x .042) | 5 | R.T.D. Temperature Probe |
| 3 | Thermodisc
(open 140°F / close 130°F) | | |

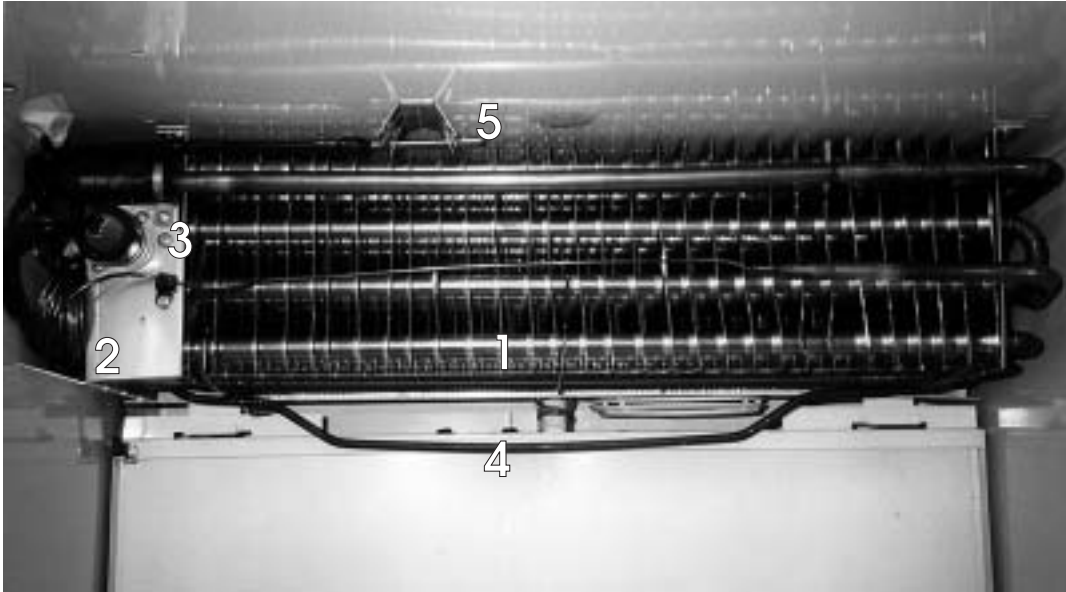

CABINET INTERIOR LAYOUT

- | | | | |
|---|----------------|---|--------------------|
| 1 | Receptacle Box | 3 | Electrical Outlet |
| 2 | 2 Amp Fuse | 4 | Incandescent Light |

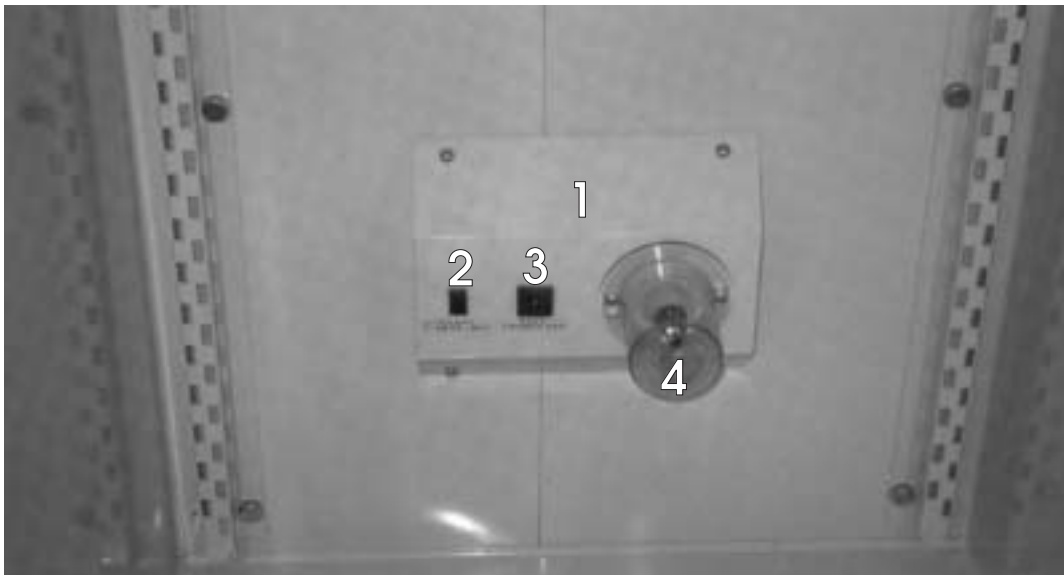

ELECTRICAL/REFRIGERATION SPECS.

Incubator

ST260RIR

SYSTEM COMPONENTS

Compressor	HP117-1-3085
Compressor BTUH / -10°F Evap	1777
Recommended Operating Temp. Range	5°F to 122°F (-15°C to 50°C)
Cabinet Volts	115
Expansion Device	Capillary .042 x 14'
Charge Refrig. Type / Oz. / Grams	R404A / 15 / 425.2

SYSTEM PERFORMANCE

AMBIENT	70°F / 21.1°C	80°F / 27°C	90°F / 32.5°C
Cavity Temp. (F / C)	31 / -2	30 / -2	30 / -2
Suction Pressure (PSIG / Kpa)	16 / 200	18 / 213	21 / 213
Discharge Pressure (PSIG / Kpa)	173 / 1068	198 / 1268	227 / 1358
Compressor Amps	2.4	2.6	2.8
Total Refrigeration Amps	10.8	6.1	10.1

TROUBLESHOOTING CHARTS

TROUBLE	COMMON CAUSE	REMEDY
UNIT WILL NOT RUN.	Blown Fuse.	Check power for "live" circuit. If outlet is "dead" but building has power, replace the fuse. Try to determine the cause of the overload or short circuit
	Low Voltage.	Check outlet with voltmeter. Should check 115V plus or minus 10%. If circuit is overloaded, either reduce load or have electrician install separate circuit. If unable to remedy any other way, install auto-transformer.
	Open motor or temperature control.	Jumper across terminals of control. If unit runs and connections are all tight, replace control. Power element may have lost charge or points may be dirty. Repair or replace thermostat.
	Open relay.	Check relay. Replace if necessary.
	Open overload.	Check overload. Replace if necessary
	Open compressor.	Check compressor. Replace if necessary.
	Open service cord.	Check with ohmmeter at unit. If no circuit and current is indicated at outlet, replace or repair.
	Broken lead to compressors or cold control.	Repair or replace broken leads.
	Service cord not plugged in.	Plug in cord.
CABINET TOO WARM.	Thermostat position set too warm, not allowing unit to operate often enough.	Turn knob to colder position.
	Fan motor not running.	Check and replace fan motor if necessary.
	Shortage of refrigerant	Check for leaks. Repair, evacuate and recharge system.
	Not enough air circulation around cabinet.	Relocate cabinet or provide clearance to allow sufficient circulation.
	Dirty condenser or obstructed condenser ducts.	Clean the condenser and the ducts.
	Thermostat control capillary not properly installed.	Refer back to removal/installation instructions detailed in this manual.

TROUBLE	COMMON CAUSE	REMEDY
CABINET RUNS CONTINUOUSLY.	Not enough air circulation around cabinet or circulation is restricted.	Relocate cabinet or provide proper clearances around cabinet. Remove restriction.
	Cooling large quantities of product or heavy loading.	Explain to customer that heavy loading causes long running time.
	Refrigerant charge undercharged or overcharged.	Check, evacuate and recharge with proper charge.
	Room temperature too warm.	Ventilate room as much as possible.
	Thermostat defective.	Check control. If it allows unit to operate all the time, replace control.
NOISY OPERATION.	Loose flooring or floor not firm.	Tighten flooring or brace floor.
	Tubing contacting cabinet or other tubing.	Move tubing gently!
	Cabinet not level.	Level cabinet.
	Compressor mechanically grounded.	Replace compressor mounts.
	Fan hitting drain pan or mechanically grounding.	Move fan.
	Shipping bands rubbing.	Make sure all shipping bands have been cut and removed.
	Loose fan blades or motor.	Tighten fan blades and/or motor.
	Loose parts or refrigeration or electrical lines out of place.	Tighten all loose fittings. Move misplaced lines.
UNIT CYCLES ON OVERLOAD.	Short relay.	Replace relay
	Weak overload protector.	Replace overload protector.
	Low voltage.	Check outlet with voltmeter. Underload voltage should be 115V plus or minus 10%. Check for several cabinets on same circuit or extremely long or underseed cord being used.
	Short compressor.	Check with meter and also ground before replacing.
CABINET LIGHTS WILL NOT WORK.	Light switch off or defective.	Try new bulb or bulbs. Inspect lampholders for signs of bad connections.
COMPRESSOR WILL NOT RUN.	Incorrect voltage.	Check voltage to compressor terminal board. Voltage must be plus or minus 10% of nameplate voltage.

TROUBLE	COMMON CAUSE	REMEDY
UNIT RUNS TOO MUCH.	Abnormally high, heavy use of cabinet.	Heavy usage requires more operation Check usage and correct or explain.
	Shortage of refrigerant. Unit must run longer and will operate at a lower than normal suction pressure.	Put in the normal charge and check for leaks.
	Overcharge of refrigerant. Excessively cold or frosted suction liner results in lost refrigeration effort.	Remove excess charge.
	Restricted air flow over condenser or air or non-condensable gases in system.	Correct the condition.
	High room temperature.	Check for temperature variance. Correct condition.
	Compressor inefficient.	Replace.
	Thermostat setting too cold.	Raise setting.
UNIT SHORT CYCLES.	Cycling on overload because of high/low line voltage with variance more or less than 10% from 115 volts. May also be caused by head pressures too high.	Check voltage, head pressure and air passages. Repair and correct condition.
PRODUCT TOO COLD.	Thermostat set too cold.	Set warmer. (Setting #1 is the warmest; #7 is the coldest.)
	Thermostat bulb contact bad.	If the bulb contact is bad, the bulb temperature will lag behind the sleeve temperature, causing the unit to run longer and make the cabinet too cold. Make sure bulb makes good contact with the bulb well.
	Room temperature abnormally low.	Correct conditions.
PRODUCT TOO WARM.	Thermostat set too warm.	Set colder. (setting #1 is the warmest; #7 the coldest.)
	Thermostat contact points dirty or burned.	Clean or replace thermostat.
	Thermostat out of adjustment.	Readjust or change thermostat.
	Excessive service load or abnormally high room temperature.	Educate customer about problems that are caused by improper loading and excessive room temperature fluctuations.
	Excessive frost accumulation.	Defrost the cabinet.

COMPRESSOR – TROUBLESHOOTING CHARTS

TROUBLE	COMMON CAUSE	REMEDY
WON'T START. NO HUM.	Open line circuit.	Check wiring, fuses, receptacle.
	Protector open.	Wait for reset—check current.
	Control contacts open.	Check control, check pressures.
	Open circuit in stator.	Replace stator or compressor.
WON'T START. HUMS INTERMITTENTLY. (cycling on protector)	Improperly wired.	Check wiring against diagram.
	Low line voltage.	Check main line voltage, determine location of voltage drop.
	Open starting capacitor.	Replace starting capacitor.
	Relay contacts not closing.	Check by operating manually. Replace relay if defective.
	Open circuit in start winding.	Check stator leads. If leads are all right, replace compressor.
	Stator winding grounded (normally will blow fuse.)	Check stator leads. If leads are all right replace compressor.
	High discharge pressure.	Eliminate cause of excessive pressure. Make sure discharge shut-off and receiver valves are open if applicable.
	Tight compressor.	Check oil level – correct binding condition, if possible. If not, replace compressor.
	Weak starting capacitor or one weak capacitor of a set.	Replace.
COMPRESSOR STARTS – MOTOR WON'T GET OFF STARTING WINDING.	Low line voltage.	Bring up voltage.
	Improperly wired.	Check wiring against diagram.
	Defective relay.	Check operation – replace relay if defective.
	Running capacitor shorted.	Check resistances. Replace capacitor if defective.
	Starting and running windings shorted.	Check capacitance – replace if defective.
	Starting capacitor weak or one of a set open.	Check capacitance. Replace if defective.
	High discharge pressure.	Check discharge shutoff valves. Check pressure.
	Tight compressor.	Check oil level. Check binding. Replace compressor if necessary.

TROUBLE	COMMON CAUSE	REMEDY
COMPRESSOR STARTS & RUNS BUT CYCLES ON PROTECTOR.	Low line voltage.	Bring up voltage.
	Additional current passing through protector.	Check for added fan motors and pumps connected to wrong side of protector.
	Suction pressure too high.	Check compressor for proper application.
	Discharge pressure too high.	Check ventilation, restrictions and overcharge.
	Protector weak.	Check current - replace protector if defective.
	Running capacitor defective.	Check capacitance. Replace if defective.
	Stator partially shorted or grounded.	Check resistances; check for ground. Replace if defective.
	Inadequate motor cooling.	Correct cooling system.
	Compressor tight.	Check oil level. Check for binding condition.
	Unbalanced line (three-phase).	Check voltage of each phase. If not equal, correct condition of unbalance.
	Discharge valve leaking or broken.	Replace valve plate.
STARTING CAPACITORS BURNT OUT.	Short cycling.	Reduce number of starts to 20 or less per hour.
	Prolonged operation on starting winding.	Reduce starting load (install crankcase pressure limit valve), increase voltage if low – replace relay if defective.
	Relay contacts sticking.	Clean contacts or replace relay.
	Improper relay or incorrect relay setting.	Replace relay.
	Improper capacitor.	Check parts list for proper capacitor rating: mfd. and voltage.
	Capacitor terminals shorted by water.	Install capacitors so terminals won't be wet.
RUNNING CAPACITORS BURNT OUT.	Excessive line voltage.	Reduce line voltage to not over 10% above rating of motor.
	High line voltage and light load.	Reduce voltage if over 10% excessive.
	Capacitor voltage rating too low.	Install capacitors with recommended voltage rating
	Capacitor terminals shorted by water	Install capacitors so terminals won't be wet.
RELAYS BURNT OUT.	Low line voltage.	Increase voltage to not less than 10% above motor rating.
	Excessive line voltage.	Reduce voltage to not more than 10% above motor rating.
	Incorrect running capacitor.	Replace with correct capacitor.
	Short cycling.	Reduce number of starts per hour.
	Relay vibrating.	Mount relay rigidly.
	Incorrect relay.	Use relay recommended for specific motor compressor.

FLUORESCENT LAMP – TROUBLESHOOTING CHARTS

The manufacturer uses standard fluorescent lamps in all of its applications. Standard one- and two-lamp ballast circuits are used.

Replacement lamps should be purchased over the counter from a local electrical wholesaler.

The table below indicates general problems that may be encountered with fluorescent lighting applications, possible causes, and corrective maintenance suggestions.

TROUBLE	COMMON CAUSE	REMEDY
NORMAL END OF LIFE. Lamp won't operate. Flashes momentarily and goes out or blinks on and off. Ends probably blackened.	Normal failure. Active material on cathodes exhausted.	Replace lamp promptly.
SHORT LIFE.	Wrong lamp type used.	Replace with lamp type marked in owner's manual.
	Wrong type of starter.	Replace with correct starter.
	Ballast not supplying the specified electrical values.	Replace with correct ballast for rating for lamp size.
	Wrong type of ballast used.	Replace ballast with proper type.
	Too low or too high voltage.	Check primary voltage with range specified on ballast name plate.
	Poor circuit contact (likely at lampholders).	Lampholders should be rigidly mounted and lamp securely seated.
	Ballast improperly or incompletely connected.	Study ballast label wiring diagram and check connections.
	Too many lamp starts.	Average life for most lamps is dependent on number of starts and hours of operation.
END BLACKENING. Dense blackening at one end or both, extending 2"-3" from base.	Normal end of life.	Replace lamp promptly.
	Mercury deposit – generally within 1" of lamp end.	Should evaporate as lamp is operated.
	Poor circuit contact likely at the lampholder.	Lampholders should be rigidly mounted and lamp securely seated.
	Ballast improperly or incompletely connected.	Study ballast wiring instructions and check connections.
	Wrong type lamp used.	Replace with correct lamp type.
	Wrong type of starter or defective starter causing on/off blinking or prolonged flashing at each start.	Replace with proper starter.
	Ballast installed not supplying the specified electrical values.	Replace with ballast of correct rating for lamp size.
	Line voltage too low or too high.	Check line voltage with range specified on ballast plate.
	Ballast improperly or incompletely connected.	Study ballast label wiring instructions and check connections.

TROUBLE	COMMON CAUSE	REMEDY
NO STARTING EFFORT OR SLOW STARTING.	Open lamp cathode circuit due to broken cathode, air leak, or by open weld.	If open, circuit is shown by continuity test or viewing end of bulb against a pinhole of light. Replace lamp.
	Wrong lamp type used.	Replace with lamp type indicated in owner's manual.
	Starter at end of life.	Replace starter.
	Starter sluggish.	Replace starter.
	Ballast installed not supplying the specified electrical values.	Replace with correct ballast of correct rating for lamp size.
	Temperature cold air contact to bulb.	Correct installation of lamp protection tubes, or shields to prevent cold air effects.
	Circuit voltage.	Check voltage and correct if possible.
DECREASED LIGHT OUTPUT. Full illumination of bulbs requires correct assembly of all components of lighting system.	Temperature operation, cold air affects lamp performance.	Properly install jacketed lamps where applicable.
	Circuit voltage.	Check voltage and correct if possible.
	Ballast improperly or incompletely connected.	Study ballast label wiring instructions and check connections.
	Dust or dirt on lamp or fixture.	Clean.
BLINKING ON/OFF: Accompanied by shimmering effect during "lighted" period.	Normal failure. Active material on cathodes exhausted.	Replace lamp promptly.
	Possible lamp fault in some lampholders.	Replace lamp. Investigate further if successive lamps blink or flicker during "lighted" period.
	Wrong type of starter or defective starter.	Replace with proper starter.
	Ballast installed not supplying the specified electrical circuit.	Replace with correct ballast with correct rating for lamp size.
	Circuit voltage.	Check voltage and correct if possible.
	Loose circuit contact.	Lampholders should be rigidly mounted and lamp securely seated.
OVERHEATED BALLAST.	Wrong lamp type used.	Replace with correct lamp number located in owner's manual.
	Wrong ballast used. Wrong voltage rating.	Replace ballast.
	Circuit voltage.	Check voltage and correct to design specifications.
	Ballast improperly or incompletely connected.	Study ballast label. Correct if installed wrong.

COMPRESSOR AREA MEDIUM TEMP. Component Identification

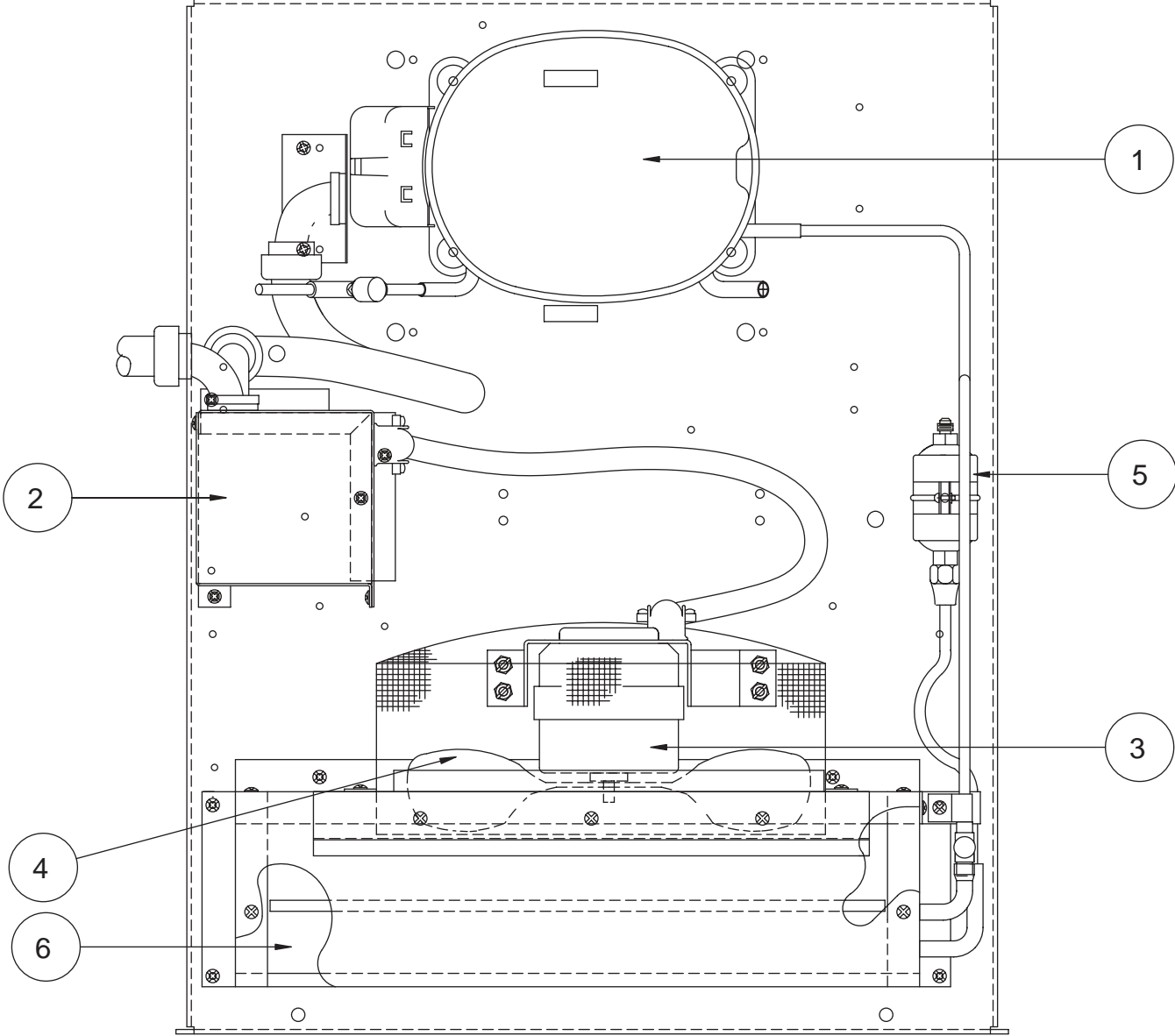

ITEM	DESCRIPTION
1	COMPRESSOR
2	START COMPONENT ASS'Y,
3	FAN MOTOR
4	FAN BLADE
5	FILTER/DRIER
6	CONDENSER COIL

ELECTRICAL BOX ASSEMBLY – (All components shown where applicable)

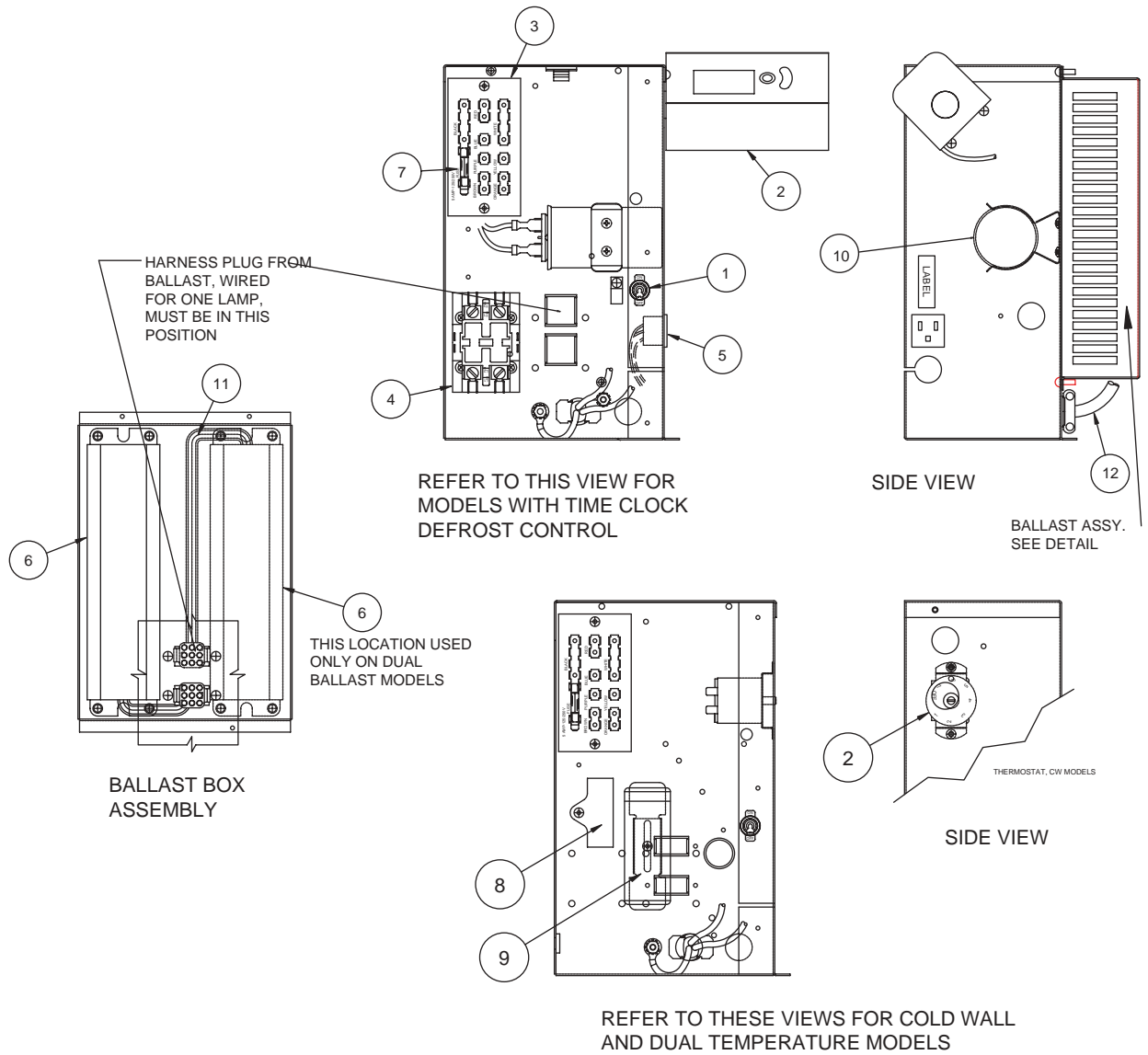

SEQ	DESCRIPTION
1	TOGGLE SWITCH, POWER
2	THERMOSTAT
3	TERMINAL BOARD
4	RELAY, POWER (SCIENTIFIC MODELS)
5	RECEPTACLE
6	BALLAST
7	FUSE
8	RUN CAPACITOR
9	START CAPACITOR
10	CAPACITOR, RUN 55 MFD/370 60
11	HARNESS, BALLAST
12	POWER CORD

START COMPONENT ASSEMBLY

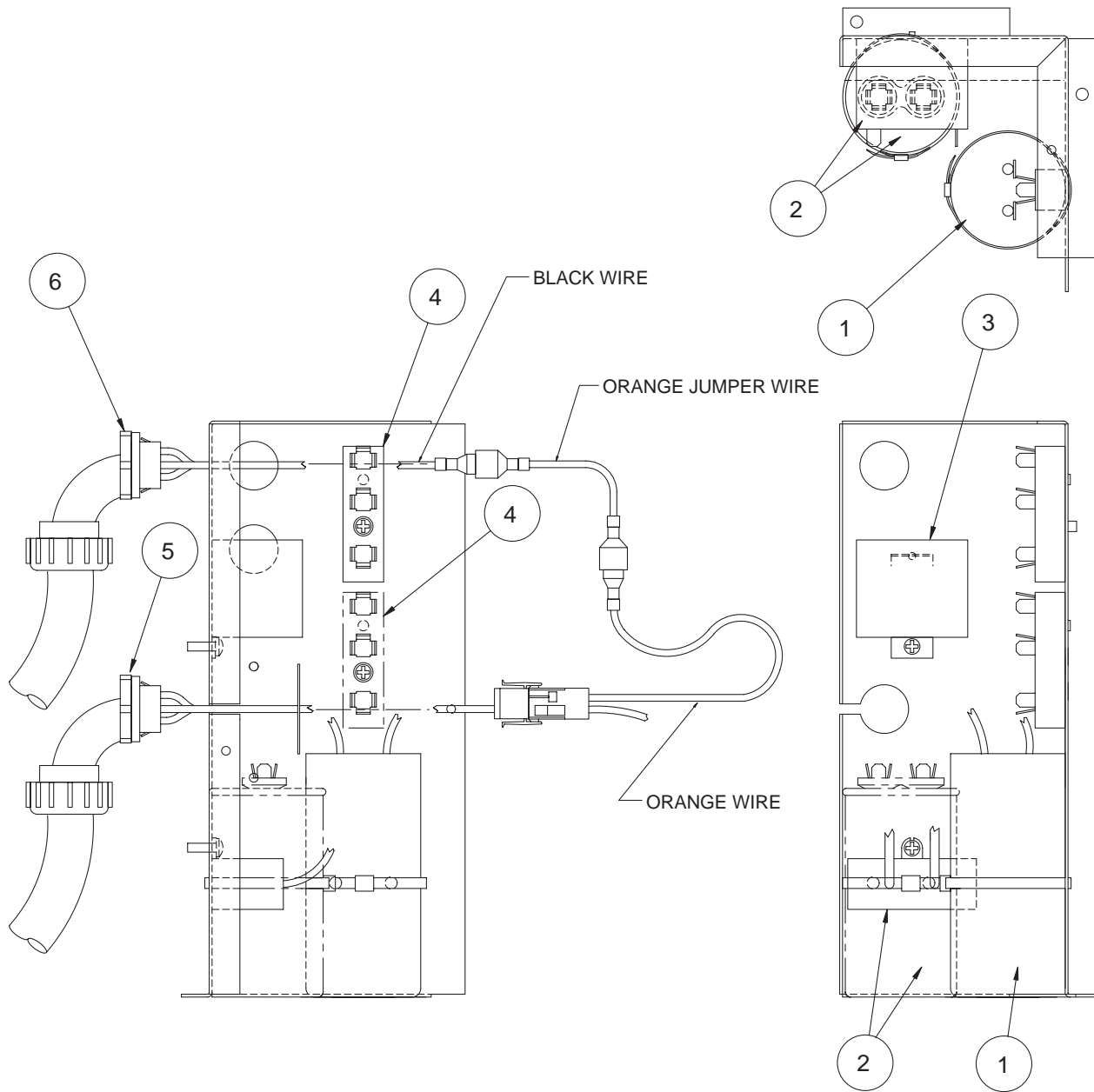

ITEM	DESCRIPTION
1	CAPACITOR, START
2	CAPACITOR, RUN
3	RELAY, START
4	TERMINAL BLOCK
5	HARNESS, COMPRESSOR
6	HARNESS, ELECTRICAL BOX

EVAPORATOR COIL ASSEMBLY

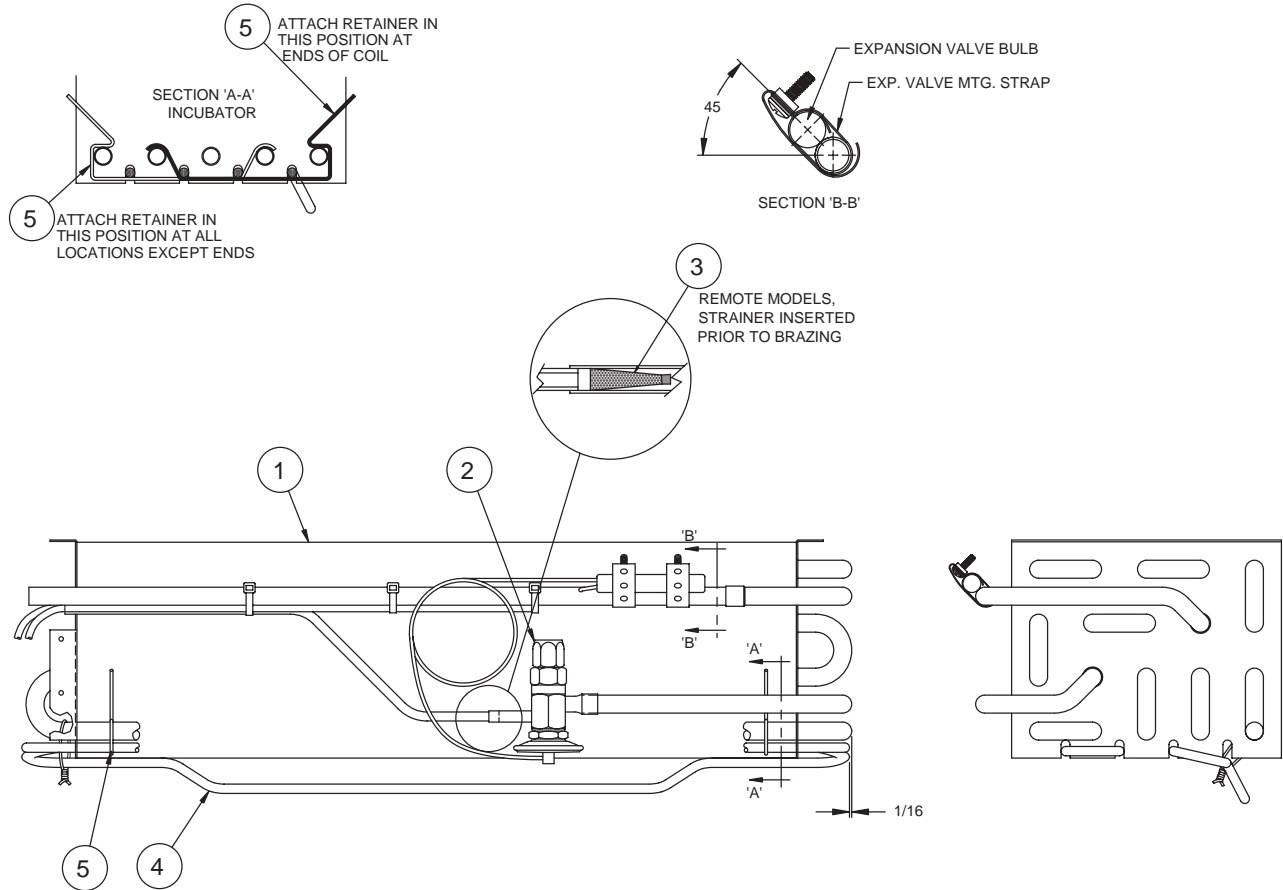

SEQ	DESCRIPTION
1	EVAPORATOR COIL
2	EXPANSION VALVE
3	STRAINER, INLET TXV
4	HEATER, DEFROST
5	RETAINER, HEATER

EVAPORATOR FAN SHROUD ASSEMBLY

NOTES:

1. WIRE LEADS MUST BE ROUTED TO PREVENT DAMAGE FROM FAN BLADE. TIE LEADS FROM ADJACENT MOTORS TO FAN GUARD TO PREVENT CONTACT.

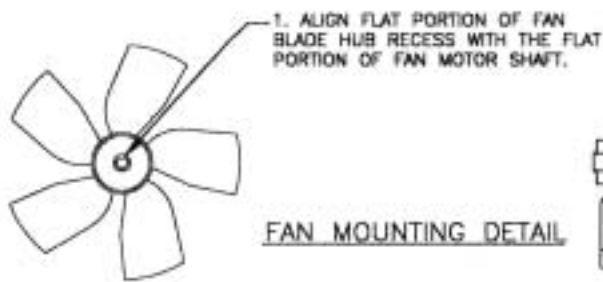
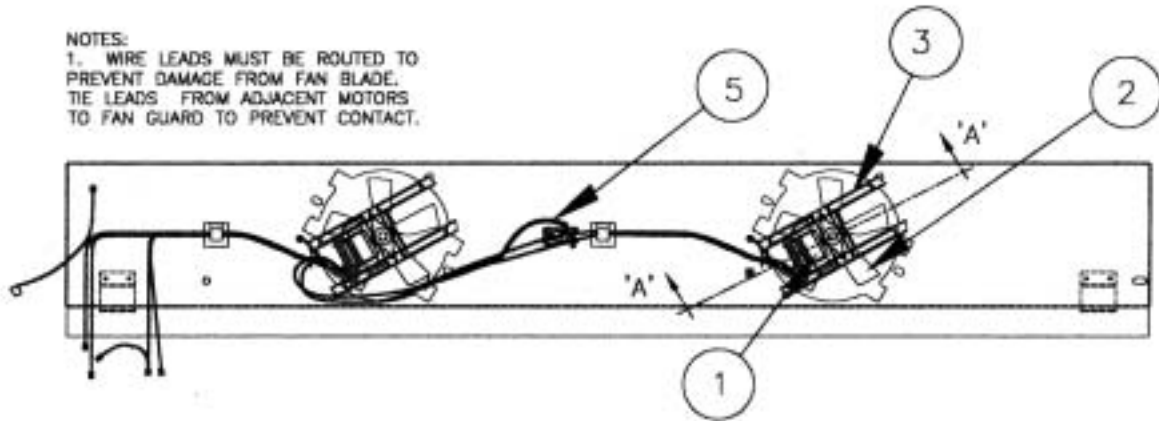

SECTION 'B-B'

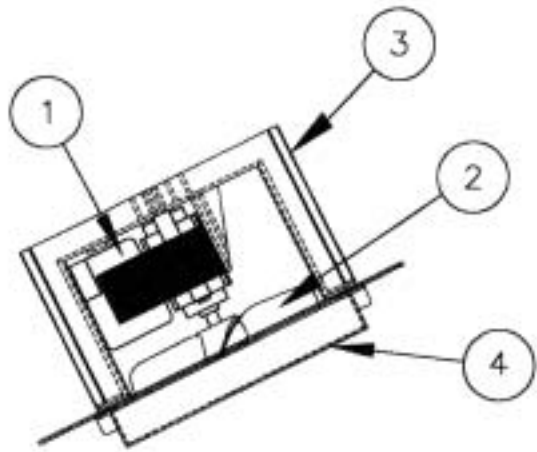
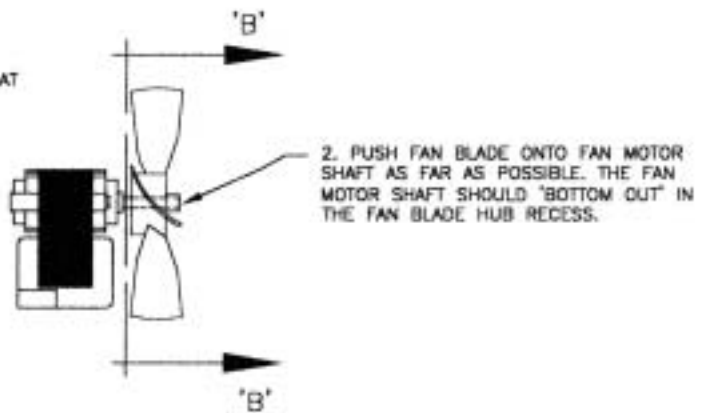

VIEW 'A' - 'A'

SEQ	DESCRIPTION
1	FAN MOTOR
2	FAN BLADE
3	MOTOR MOUNT
4	GRILL
5	HARNESS, DRAIN HEATER

SIDE LIGHT ASSEMBLY

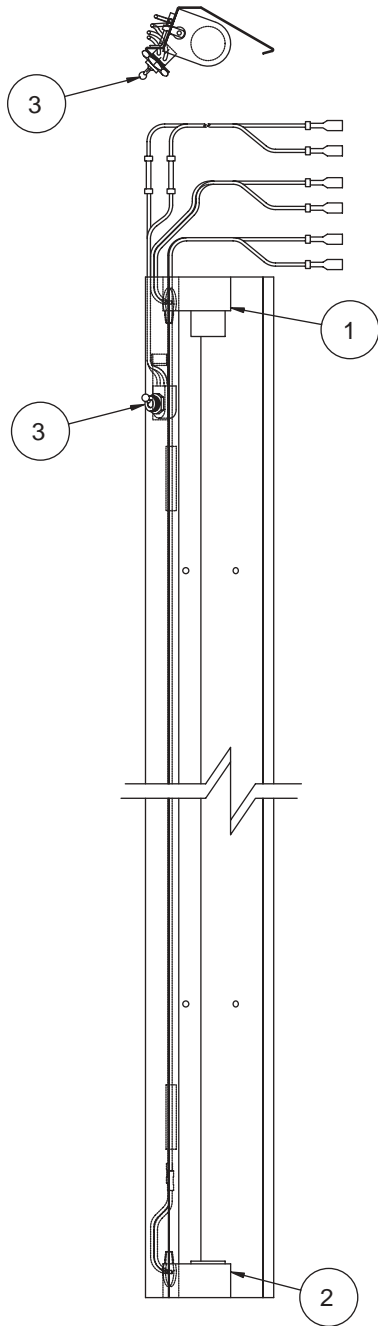

ASSEMBLY SHOWN IS LEFT SIDE FOR TOP MOUNT MODELS. ON BOTTOM MOUNT MODELS WIRES EXIT AT THE BOTTOM AND THE SWITCH IS MOUNTED IN THE RIGHT SIDE ASSEMBLY. ON SCIENTIFIC MODELS, SWITCH IS MOUNTED IN THE CONTROL PANEL.

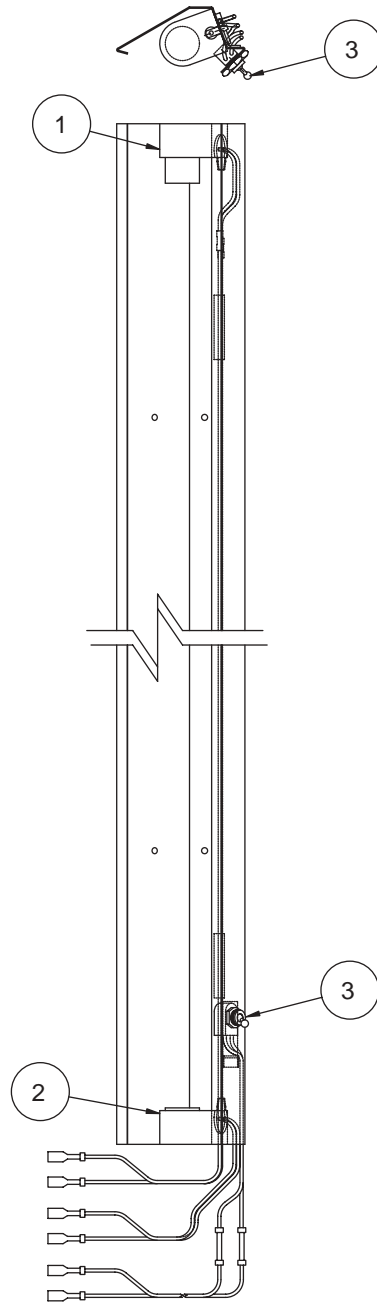

ASSEMBLY SHOWN IS RIGHT SIDE FOR BOTTOM MOUNT MODELS. ON TOP MOUNT MODELS WIRES EXIT AT THE TOP AND THE SWITCH IS MOUNTED IN THE LEFT SIDE ASSEMBLY. ON SCIENTIFIC MODELS, SWITCH IS MOUNTED IN THE CONTROL PANEL.

SEQ	DESCRIPTION
1	LAMPHOLDER, TOP (SPRING LOADED PLUNGER)
2	LAMPHOLDER, BOTTOM (STATIONARY)
3	SWITCH, TOGGLE

MULLION LAMP ASSEMBLY

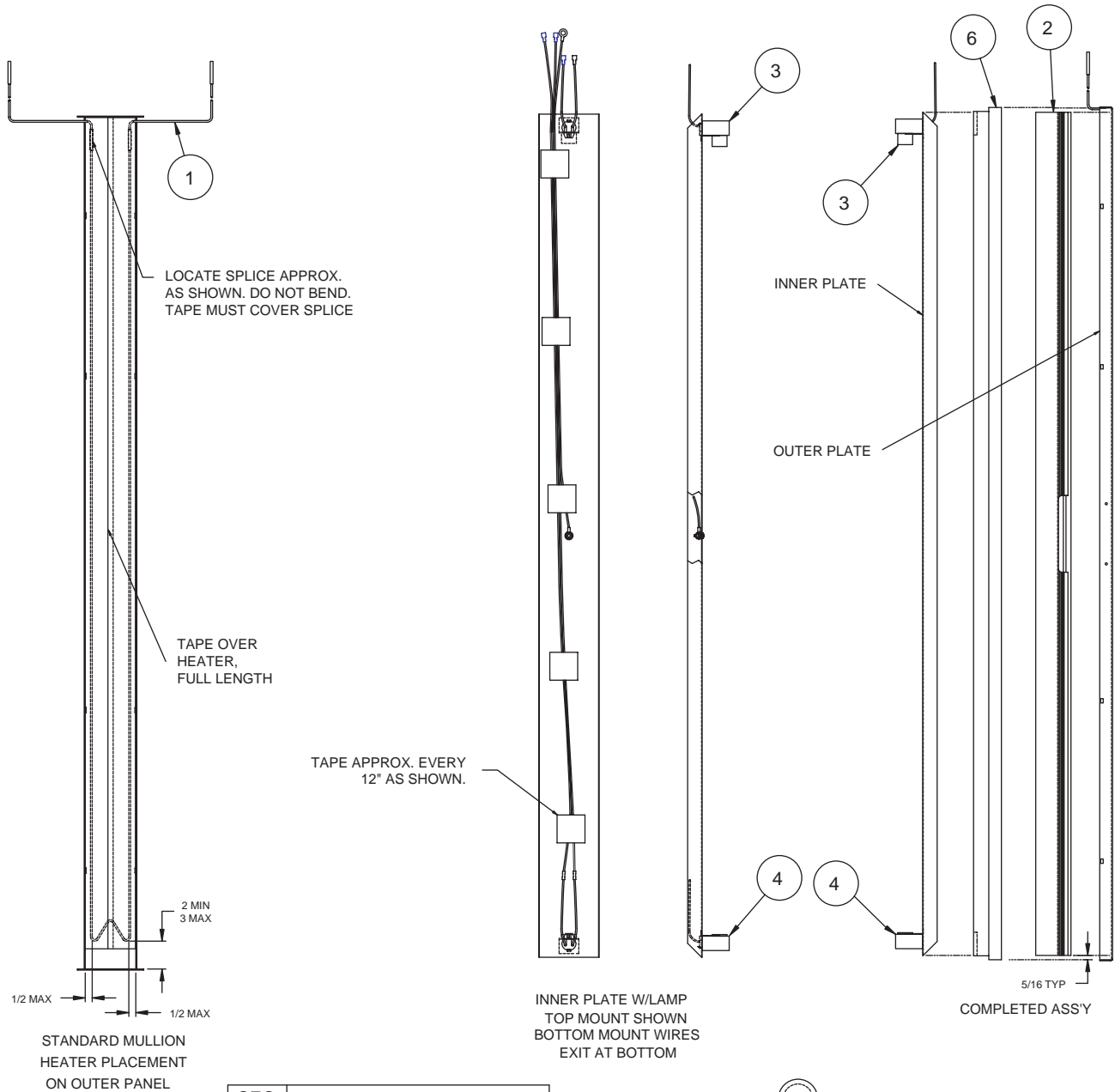

SEQ	DESCRIPTION
1	HEATER
2	BREAKER
3	TOP LAMPHOLDER
4	BOTTOM LAMPHOLDER
5	SUPPLY HARNESS
6	INSULATION

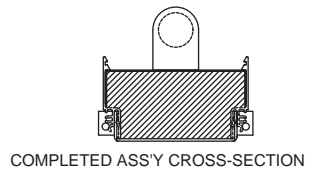

EVAPORATOR & FAN AREA

BT30RSFMS
BT50RSFMS

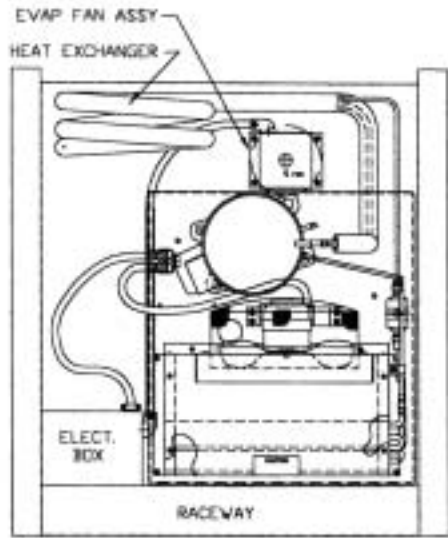

TOP VIEW
ONE DOOR F.M.S.

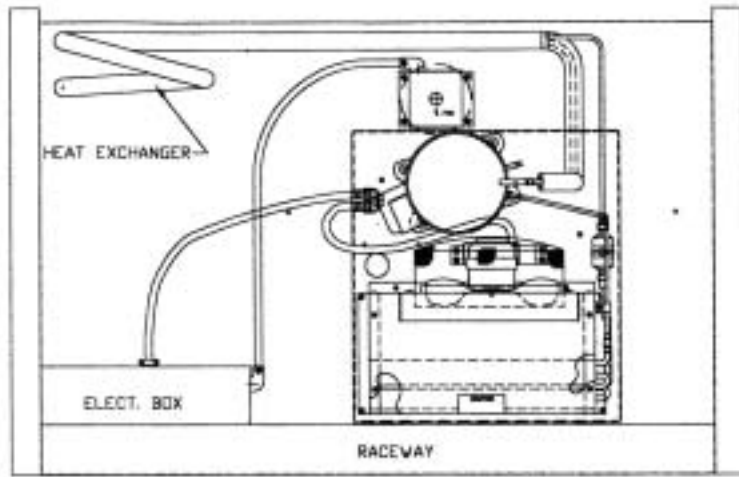

TOP VIEW
TWO DOOR F.M.S.

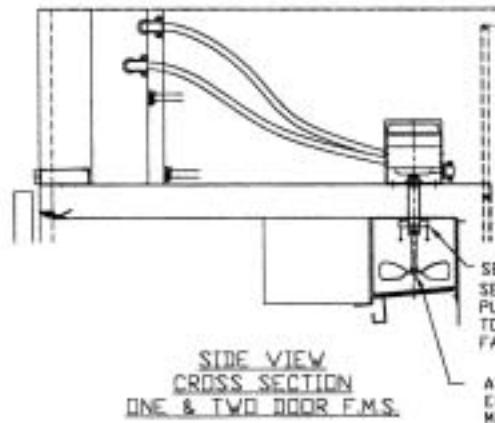
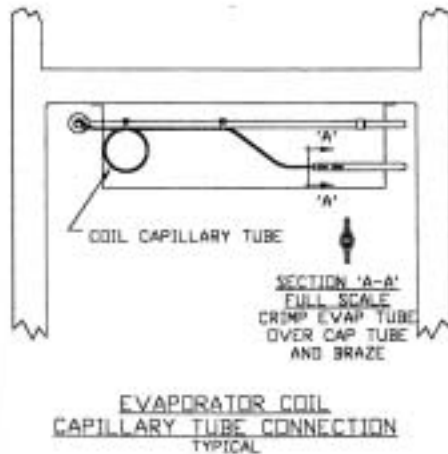

SECTION IV

PART LISTS

WHEN ORDERING PARTS FURNISH COMPLETE MODEL & SERIAL # INFORMATION.

Keep This Manual for Future Reference

Engineering and Technical Data are Subject to Change Without Notice.

PARTS LIST - One Door

PARTS LIST - ONE DOOR MEDIUM TEMPERATURE									
	T30MGP-4.1	UMG30BS-4.1	UMH30BS-4.1	BT30RG-4.1	BT30RGCH-4.1	ST30RGG-4.1	T30MSP-4.1	BT30RS-4.1	BT30RSFMS-4.1
Compressor	16-0221-00	16-0221-00	16-0221-00	16-0221-00	16-0221-00	16-0221-00	16-0310-00	16-0310-00	16-0308-00
Start Relay							17-0286-00	17-0286-00	17-0286-00
Start Capacitor	17-0143-00	17-0143-00	17-0143-00	17-0143-00	17-0143-00	17-0143-00	17-0291-00	17-0291-00	17-0291-00
Run Capacitor							17-0288-00	17-0288-00	17-0288-00
Motor Protector, Compr							17-0316-00	17-0316-00	17-0314-00
Condenser Coil	18-1211-01	18-1211-01	18-1211-01	18-1211-01	18-1211-01	18-1211-01	18-1211-01	18-1211-01	18-1211-01
Fan Motor, Cond	19-0933-00	19-0933-00	19-0933-00	19-0933-00	19-0933-00	19-0933-00	19-0933-00	19-0933-00	19-0933-00
Fan Blade, Cond	19-0101-00	19-0101-00	19-0101-00	19-0101-00	19-0101-00	19-0101-00	19-0101-00	19-0101-00	19-0101-00
Filter/Drier	18-1106-00	18-1106-00	18-1106-00	18-1106-00	18-1106-00	18-1106-00	18-1106-00	18-1106-00	18-1106-00
Heat Exchange	50-0219-01	50-3682-00	50-3682-00	50-0219-01	50-0219-01	50-0219-01	50-0222-01	50-0222-01	50-3783-02
Evaporator Coil	18-0713-00	18-0713-00	18-0713-00	18-0713-00	18-0713-00	18-0713-00	18-0713-00	18-0713-00	18-0713-00
Expansion Valve	18-0386-08	18-0386-08	18-0386-08	18-0386-08	18-0386-08	18-0386-08			
Capillary Tube							14-2403-00	14-2403-00	14-2408-00
Harness, Evap	19-1652-02	19-1652-02	19-1652-02	19-1652-02	19-1652-02	19-1652-02	19-1652-02	19-1652-02	
Fan Motor, Evap	19-1221-00	19-1221-00	19-1221-00	19-1221-00	19-1221-00	19-1221-00	19-1221-00	19-1221-00	24-0500
Fan Blade, Evap	19-1223-00	19-1223-00	19-1223-00	19-1223-00	19-1223-00	19-1223-00	19-1223-00	19-1223-00	19-1042-00
Motor Mount, Evap	10-1478-00	10-1478-00	10-1478-00	10-1478-00	10-1478-00	10-1478-00	10-1478-00	10-1478-00	
Grill, Evap Fan	10-1479-00	10-1479-00	10-1479-00	10-1479-00	10-1479-00	10-1479-00	10-1479-00	10-1479-00	15-0291-00
Switch, Power	19-0103-00	19-0103-00	19-0103-00	19-1006-00	19-1006-00	19-1006-00	19-0103-00	19-1006-00	19-1006-00
Relay, Power				19-1005-00	19-1005-00	19-1005-00		19-1005-00	19-1005-00
Thermostat, Cabinet	19-1030-02	19-1030-02	19-1030-02	19-1030-02	19-1030-02	19-1031-00	19-1030-02	19-1030-02	19-1031-00
Power Cord	19-0620-00	19-0620-00	19-0620-00	19-0620-00	19-0620-00	19-0967-00	19-0620-00	19-0620-00	19-0620-00
Harness, Ebox to Main	19-1675-02	19-1675-02	19-1675-02	19-1675-02	19-1675-02	19-1675-02	19-1675-02	19-1675-02	
Heater, Cond Pan	19-1688-00	19-1688-00	19-1688-00	19-1688-00	19-1688-00	19-1688-00	19-1688-00	19-1688-00	
Ballast	19-1725-00	19-1725-00	19-1725-00	19-1725-00	19-1725-00	19-1725-00			
Harness, Ballast	19-1730-00	19-1730-00	19-1730-00	19-1730-00	19-1730-00	19-1730-00			
Fuse, Lights	19-0970-00	19-0970-00	19-0970-00	19-0970-00	19-0970-00	19-0970-00			
Lampholder, Top	19-0957-01	19-0957-01	19-0957-01	19-0957-01	19-0957-01	19-0957-01		503-248D	
Lampholder, Bottom	19-0957-02	19-0957-02	19-0957-02	19-0957-02	19-0957-02	19-0957-02			
Switch, Light	19-0729-00	19-0729-00	19-0729-00	19-1003-00	19-1003-00	19-1003-00			
Lamp	19-1040-00	19-1040-00	19-1040-00	19-1040-00	19-1040-00	19-1040-00		22-0213	
Safety Shield, Lamp	10-0983-00	10-0983-00	10-0983-00	10-0983-00	10-0983-00	10-0983-00			
Cover, Lamp	10-0809-00	10-0809-00	10-0809-00	10-0809-00	10-0809-00	10-0809-00		44-1034	
Breaker Trim, Side	10-1485-02	10-1485-02	10-1485-02	10-1485-02	10-1485-02	10-1485-02	10-1485-02	10-1485-02	10-1485-02
Breaker Trim, Top/Btm	10-1485-03	10-1485-03	10-1485-03	10-1485-03	10-1485-03	10-1485-03	10-1485-03	10-1485-03	10-1485-03
Thermometer, Solar				19-1050-03	19-1050-03		19-1974-00	19-1050-03	19-1050-03
Switch, Door						19-0969-00		19-0969-00	
Hinge, Lower LH		03-1232-01	03-1232-01						
Hinge, Lower RH	03-1232-02			03-1232-02	03-1232-02	03-1232-02	25-0178-09	25-0178-09	25-0178-09
Hinge, Upper LH		03-1231-03	03-1231-03						
Hinge, Upper RH	03-1231-04			03-1231-04	03-1231-04	03-1231-04	25-0178-03	25-0178-03	25-0178-03
Hold Open Arm, RH				25-0543-02	25-0543-02	25-0543-02			
Door Assy, LH		51-0988-07	51-0988-19						
Door Assy, RH	51-1027-08			51-1027-16	51-1027-16	51-1027-20	51-0172-02	51-0172-02	51-0172-02
Door Closer	50-3159-00	50-3159-00	50-3159-00	50-3159-00	50-3159-00	50-3159-00	25-0178-01	25-0178-01	25-0178-01
Gasket, Door	10-0822-02	10-0822-02	10-0822-02	10-0822-02	10-0822-02	10-0822-02	10-0882-05	10-0882-05	10-0882-05
Handle, Door	25-0518-00	25-0409-00	25-0409-00	25-5055-00	25-5055-00	25-5055-00	25-5055-00	25-5055-00	25-5055-00
Lock, Door				25-0412-02	25-0412-02	25-0412-02	25-0226-00	25-0226-00	25-0226-00
Shelf, Cantilever	15-0267-00	15-0267-00	15-0267-00	15-0325-00	15-0284-00		15-0267-00	15-0325-00	15-0325-00
Shelf, Bottom	15-0197-03	15-0197-03	15-0197-03	15-0197-03	15-0197-03		15-0197-03	15-0197-03	15-0197-03
Drawer Assembly						50-3145-03			
Pole Mast					15-0285-00				
Leg, Adjustable	33-0504-01			33-0504-01	33-0504-01	33-0504-01	33-0504-01	33-0504-01	33-0504-01
Front/Control Panel Assy	50-0176-01	50-0176-01	50-0176-01	51-0174-01	51-0174-01	50-2999-46	50-0176-11	51-0174-04	51-0174-04

PARTS LIST – Two Door

PARTS LIST - TWO DOOR MEDIUM TEMPERATURE									
	T50MGP-4.1	UMG50BS-4.1	UMH50BS-4.1	BT50RG-4.1	BT50RGCH-4.1	ST50RGBB-4.1	T50MSP-4.1	BT50RS-4.1	BT50RSFMS-4.1
Compressor	16-0222-00	16-0222-00	16-0222-00	16-0222-00	16-0222-00	16-0222-00	16-0310-00	16-0310-00	16-0308-00
Start Relay	17-0146-00	17-0146-00	17-0146-00	17-0146-00	17-0146-00	17-0146-00	17-0286-00	17-0286-00	17-0286-00
Start Capacitor	17-0147-00	17-0147-00	17-0147-00	17-0147-00	17-0147-00	17-0147-00	17-0291-00	17-0291-00	17-0291-00
Run Capacitor	17-0149-00	17-0149-00	17-0149-00	17-0149-00	17-0149-00	17-0149-00	17-0288-00	17-0288-00	17-0288-00
Motor Protector, Compr							17-0316-00	17-0316-00	17-0314-00
Condenser Coil	18-0546-02	18-0546-02	18-0546-02	18-0546-02	18-0546-02	18-0546-02	18-1211-01	18-1211-01	18-1211-01
Fan Motor, Cond	19-0933-00	19-0933-00	19-0933-00	19-0933-00	19-0933-00	19-0933-00	19-0933-00	19-0933-00	19-0933-00
Fan Blade, Cond	19-0101-00	19-0101-00	19-0101-00	19-0101-00	19-0101-00	19-0101-00	19-0101-00	19-0101-00	19-0101-00
Filter/Drier	18-1106-00	18-1106-00	18-1106-00	18-1106-00	18-1106-00	18-1106-00	18-1106-00	18-1106-00	18-1106-00
Heat Exchange	50-0218-00	50-0218-00	50-0218-00	50-0218-00	50-0218-00	50-0218-00	50-0222-02	50-0222-02	50-3783-03
Evaporator Coil	18-0713-00	18-0713-00	18-0713-00	18-0713-00	18-0713-00	18-0713-00	18-0713-00	18-0713-00	18-0713-00
Expansion Valve	18-0386-08	18-0386-08	18-0386-08	18-0386-08	18-0386-08	18-0386-08			
Capillary Tube							14-2403-00	14-2403-00	14-2408-00
Harness, Evap	19-1652-02	19-1652-02	19-1652-02	19-1652-02	19-1652-02	19-1652-02	19-1652-02	19-1652-02	
Fan Motor, Evap	19-1221-00	19-1221-00	19-1221-00	19-1221-00	19-1221-00	19-1221-00	19-1221-00	19-1221-00	24-0500
Fan Blade, Evap	19-1223-00	19-1223-00	19-1223-00	19-1223-00	19-1223-00	19-1223-00	19-1223-00	19-1223-00	19-1042-00
Motor Mount, Evap	10-1478-00	10-1478-00	10-1478-00	10-1478-00	10-1478-00	10-1478-00	10-1478-00	10-1478-00	
Grill, Evap Fan	10-1479-00	10-1479-00	10-1479-00	10-1479-00	10-1479-00	10-1479-00	10-1479-00	10-1479-00	15-0291-00
Switch, Power	19-0103-00	19-0103-00	19-0103-00	19-1006-00	19-1006-00	19-1006-00	19-0103-00	19-1006-00	19-1006-00
Relay, Power				19-1005-00	19-1005-00	19-1005-00		19-1005-00	19-1005-00
Thermostat, Cabinet	19-1030-02	19-1030-02	19-1030-02	19-1030-02	19-1030-02	19-1030-02	19-1030-02	19-1030-02	19-1031-00
Power Cord	19-0967-00	19-0967-00	19-0967-00	19-0967-00	19-0967-00	19-0967-00	19-0620-00	19-0620-00	19-0620-00
Harness, Ebox to Main	19-1675-02	19-1675-02	19-1675-02	19-1675-02	19-1675-02	19-1675-02	19-1675-02	19-1675-02	
Heater, Cond Pan	19-1688-00			19-1688-00	19-1688-00	19-1688-00	19-1688-00	19-1688-00	
Ballast	19-1725-00	19-1725-00	19-1725-00	19-1725-00	19-1725-00	19-1725-00			
Harness, Ballast	19-1730-00	19-1730-00	19-1730-00	19-1730-00	19-1730-00	19-1730-00			
Fuse, Lights	19-0970-00	19-0970-00	19-0970-00	19-0970-00	19-0970-00	19-0970-00			
Lampholder, Top	19-0957-01	19-0957-01	19-0957-01	19-0957-01	19-0957-01	19-0957-01		503-248D	
Lampholder, Bottom	19-0957-02	19-0957-02	19-0957-02	19-0957-02	19-0957-02	19-0957-02			
Switch, Light	19-0729-00	19-0729-00	19-0729-00	19-1003-00	19-1003-00	19-1003-00			
Lamp	19-1040-00	19-1040-00	19-1040-00	19-1040-00	19-1040-00	19-1040-00		22-0213	
Safety Shield, Lamp	10-0983-00	10-0983-00	10-0983-00	10-0983-00	10-0983-00	10-0983-00			
Cover, Lamp	10-0809-00	10-0809-00	10-0809-00	10-0809-00	10-0809-00	10-0809-00		44-1034	
Heater, Vert Mullion	19-1657-01	19-1657-01	19-1657-01	19-1657-01	19-1657-01	19-1657-01	19-1657-01	19-1657-01	
Breaker Trim, Side	10-1485-02	10-1485-02	10-1485-02	10-1485-02	10-1485-02	10-1485-02	10-1485-02	10-1485-02	10-1485-02
Breaker Trim, Top/Btm	10-1485-04	10-1485-04	10-1485-04	10-1485-04	10-1485-04	10-1485-04	10-1485-04	10-1485-04	10-1485-04
Thermometer, Solar				19-1050-03	19-1050-03		19-1974-00	19-1050-03	19-1050-03
Switch, Door						19-0969-00		19-0969-00	
Hinge, Lower LH	03-1232-01	03-1232-01	03-1232-01	03-1232-01	03-1232-01	03-1232-01	25-0178-08	25-0178-08	25-0178-08
Hinge, Lower RH	03-1232-02	03-1232-02	03-1232-02	03-1232-02	03-1232-02	03-1232-02	25-0178-09	25-0178-09	25-0178-09
Hinge, Upper LH	03-1231-03	03-1231-03	03-1231-03	03-1231-03	03-1231-03	03-1231-03	25-0178-02	25-0178-02	25-0178-02
Hinge, Upper RH	03-1231-04	03-1231-04	03-1231-04	03-1231-04	03-1231-04	03-1231-04	25-0178-03	25-0178-03	25-0178-03
Hold Open Arm, LH				25-0543-01	25-0543-01	25-0543-01			
Hold Open Arm, RH				25-0543-02	25-0543-02	25-0543-02			
Door Assy, LH	51-1027-05	51-0988-05	51-0988-17	51-1027-13	51-1027-13	51-1027-21	51-0172-05	51-0172-05	51-0172-05
Door Assy, RH	51-1027-06	51-0988-06	51-0988-18	51-1027-14	51-1027-14	51-1027-22	51-0172-06	51-0172-06	51-0172-06
Door Closer	50-3159-00	50-3159-00	50-3159-00	50-3159-00	50-3159-00	50-3159-00	25-0178-01	25-0178-01	25-0178-01
Gasket, Door	10-0822-01	10-0822-01	10-0822-01	10-0822-01	10-0822-01	10-0822-01	10-0882-05	10-0882-05	10-0882-05
Handle, Door	25-0518-00	25-0409-00	25-0409-00	25-5055-00	25-5055-00	25-5055-00	25-5055-00	25-5055-00	25-5055-00
Lock, LH Door				25-0412-01	25-0412-01	25-0412-01	25-0226-00	25-0226-00	25-0226-00
Lock, RH Door				25-0412-02	25-0412-02	25-0412-02	25-0226-00	25-0226-00	25-0226-00
Shelf, Cantilever	15-0267-00	15-0267-00	15-0267-00	15-0267-00	15-0267-00		15-0267-00	15-0267-00	15-0267-00
Shelf, Bottom	15-0197-03	15-0197-03	15-0197-03	15-0197-03	15-0197-03		15-0197-03	15-0197-03	15-0197-03
Shelf, Cantilever Half					15-0284-00				
Drawer Assembly						50-3145-04			
Pole Mast					15-0285-00				
Leg, Adjustable	33-0504-01			33-0504-01	33-0504-01	33-0504-01	33-0504-01	33-0504-01	33-0504-01
Front/Control Panel Assy	50-0176-02	50-0176-02	50-0176-02	51-0174-02	51-0174-02	50-2999-47	50-0176-12	51-0174-05	51-0174-05

PARTS LIST – Three Door

PARTS - LIST THREE DOOR MEDIUM TEMPERATURE				
	T80MGP-4.1	UMG80BS-4.1	UMH80BS-4.1	BT80RG-4.1
Compressor	16-0222-00	16-0222-00	16-0222-00	16-0222-00
Start Relay	17-0146-00	17-0146-00	17-0146-00	17-0146-00
Start Capacitor	17-0147-00	17-0147-00	17-0147-00	17-0147-00
Run Capacitor	17-0149-00	17-0149-00	17-0149-00	17-0149-00
Condenser Coil	18-0546-02	18-0546-02	18-0546-02	18-0546-02
Fan Motor, Cond	24-0396	24-0396	24-0396	24-0396
Fan Blade, Cond	19-0410-00	19-0410-00	19-0410-00	19-0410-00
Filter/Drier	18-1106-00	18-1106-00	18-1106-00	18-1106-00
Heat Exchange	50-0218-00	50-3682-00	50-3682-00	50-0218-00
Evaporator Coil	18-0714-01	18-0714-01	18-0714-01	18-0714-01
Expansion Valve	18-0386-09	18-0386-09	18-0386-09	18-0386-09
Harness, Evap	19-1652-02	19-1652-02	19-1652-02	19-1652-02
Fan Motor, Evap	19-1221-00	19-1221-00	19-1221-00	19-1221-00
Fan Blade, Evap	19-1223-00	19-1223-00	19-1223-00	19-1223-00
Motor Mount, Evap	10-1478-00	10-1478-00	10-1478-00	10-1478-00
Grill, Evap Fan	10-1479-00	10-1479-00	10-1479-00	10-1479-00
Switch, Power	19-1003-00	19-1003-00	19-1003-00	19-1006-00
Relay, Power				19-1005-00
Thermostat, Cabinet	19-1030-02	19-1030-02	19-1030-02	19-1030-02
Power Cord	19-0967-00	19-0967-00	19-0967-00	19-0967-00
Harness, Ebox to Main	19-1675-02	19-1675-02	19-1675-02	19-1675-02
Heater, Cond Pan	19-1688-00			19-1688-00
Ballast	19-1725-00	19-1725-00	19-1725-00	19-1725-00
Harness, Ballast	19-1730-00	19-1730-00	19-1730-00	19-1730-00
Fuse, Lights	19-0970-00	19-0970-00	19-0970-00	19-0970-00
Lampholder, Top	19-0957-01	19-0957-01	19-0957-01	19-0957-01
Lampholder, Bottom	19-0957-02	19-0957-02	19-0957-02	19-0957-02
Switch, Light	19-0729-00	19-0729-00	19-0729-00	19-0729-00
Lamp	19-1040-00	19-1040-00	19-1040-00	19-1040-00
Safety Shield, Lamp	10-0983-00	10-0983-00	10-0983-00	10-0983-00
Cover, Lamp	10-0809-00	10-0809-00	10-0809-00	10-0809-00
Heater, Vert Mullion	19-1657-01	19-1657-01	19-1657-01	19-1657-01
Breaker Trim, Side	10-1485-02	10-1485-02	10-1485-02	10-1485-02
Breaker Trim, Top/Btm	10-1485-04	10-1485-04	10-1485-04	10-1485-04
Breaker Trim, Top/Btm Ctr	10-1485-05	10-1485-05	10-1485-05	10-1485-05
Thermometer, Solar				19-1050-03
Hinge, Lower LH	03-1232-01	03-1232-01	03-1232-01	03-1232-01
Hinge, Upper LH	03-1231-03	03-1231-03	03-1231-03	03-1231-03
Hold Open Arm, LH				25-0543-01
Door Assy, LH	51-1027-05	51-0988-05	51-0988-17	51-1027-13
Door Closer	50-3159-00	50-3159-00	50-3159-00	50-3159-00
Gasket, Door	10-0822-01	10-0822-01	10-0822-01	10-0822-01
Handle, Door	25-0518-00	25-0409-00	25-0409-00	25-5055-00
Shelf, Cantilever	15-0267-00	15-0267-00	15-0267-00	15-0267-00
Shelf, Bottom	15-0197-03	15-0197-03	15-0197-03	15-0197-03
Leg, Adjustable	33-0504-01			33-0504-01
Front/Control Panel Assy	50-0176-03	50-0176-03	50-0176-03	51-0174-03

PARTS LIST – Remote Condensing Unit

PARTS LIST - REMOTE CONDENSING UNIT MEDIUM TEMPERATURE				
	T50MGPR-4.1	UMG50RS-4.1	T80MGPR-4.1	UMG80RS-4.1
Heat Exchange	50-0149-00	50-0148-00	50-0149-00	50-0148-00
Solenoid Valve	19-3037-00	19-3037-00	19-3037-00	19-3037-00
Evaporator Coil	18-0713-00	18-0713-00	18-0714-01	18-0714-01
Expansion Valve	18-0386-08	18-0386-08	18-0386-09	18-0386-09
Strainer, TXV Inlet	18-0389-00	18-0389-00	18-0389-00	18-0389-00
Harness, Evap	19-1652-02	19-1652-02	19-1652-02	19-1652-02
Fan Motor, Evap	19-1221-00	19-1221-00	19-1221-00	19-1221-00
Fan Blade, Evap	19-1223-00	19-1223-00	19-1223-00	19-1223-00
Motor Mount, Evap	10-1478-00	10-1478-00	10-1478-00	10-1478-00
Grill, Evap Fan	10-1479-00	10-1479-00	10-1479-00	10-1479-00
Switch, Power	19-0103-00	19-0103-00	19-0103-00	19-0103-00
Thermostat, Cabinet	19-1030-02	19-1030-02	19-1030-02	19-1030-02
Harness, Ebox to Main	19-1675-02	19-1675-02	19-1675-02	19-1675-02
Heater, Cond Pan	19-1688-00		19-1688-00	
Ballast	19-1725-00	19-1725-00	19-1725-00	19-1725-00
Harness, Ballast	19-1730-00	19-1730-00	19-1730-00	19-1730-00
Fuse, Lights	19-0970-00	19-0970-00	19-0970-00	19-0970-00
Lampholder, Top	19-0957-01	19-0957-01	19-0957-01	19-0957-01
Lampholder, Bottom	19-0957-02	19-0957-02	19-0957-02	19-0957-02
Switch, Light	19-0729-00	19-0729-00	19-0729-00	19-0729-00
Lamp	19-1040-00	19-1040-00	19-1040-00	19-1040-00
Safety Shield, Lamp	10-0983-00	10-0983-00	10-0983-00	10-0983-00
Cover, Lamp	10-0809-00	10-0809-00	10-0809-00	10-0809-00
Heater, Vert Mullion	19-1657-01	19-1657-01	19-1657-01	19-1657-01
Breaker Trim, Side	10-1485-02	10-1485-02	10-1485-02	10-1485-02
Breaker Trim, Top/Btm	10-1485-04	10-1485-04	10-1485-04	10-1485-04
Breaker Trim, Top/Btm Ctr			10-1485-05	10-1485-05
Hinge, Lower LH	03-1232-01	03-1232-01	03-1232-01	03-1232-01
Hinge, Lower RH	03-1232-02	03-1232-02		
Hinge, Upper LH	03-1231-03	03-1231-03	03-1231-03	03-1231-03
Hinge, Upper RH	03-1231-04	03-1231-04		
Door Assy, LH	51-1027-05	51-0988-05	51-1027-05	51-0988-05
Door Assy, RH	51-1027-06	51-0988-06		
Door Closer	50-3159-00	50-3159-00	50-3159-00	50-3159-00
Gasket, Door	10-0822-01	10-0822-01	10-0822-01	10-0822-01
Handle, Door	25-0518-00	25-0409-00	25-0518-00	25-0409-00
Shelf, Cantilever	15-0267-00	15-0267-00	15-0267-00	15-0267-00
Shelf, Bottom	15-0197-03	15-0197-03	15-0197-03	15-0197-03
Leg, Adjustable	33-0504-01		33-0504-01	
Front/Control Panel Assy	50-0176-02	50-0176-02	50-0176-03	50-0176-03

PARTS LIST – Refrigerator/Freezer FMS & EXPR, & Incubator

PARTS LIST - REFRIGERATOR/FREEZER FMS & EXPR, & INCUBATOR			
	BT30RF-FMS	BT30RF- EXPR	ST260RIR-4.1
Compressor	16-0308-00	16-0263-00	16-0309-00
Start Relay	17-0286-00		17-0286-00
Start Capacitor	17-0291-00		17-0291-00
Run Capacitor	17-0288-00		17-0288-00
Motor Protector, Compr	17-0314-00		17-0315-00
Condenser Coil	18-1214-01	18-1214-01	18-1211-01
Fan Motor, Cond			19-0933-00
Fan Blade, Cond			19-0101-00
Filter/Drier	12-3024	12-3024	18-1106-00
Heat Exchange	50-4056-01	50-3866-00	50-3783-01
Capillary Tube	14-2401-00	10-9003	10-9032
Evaporator Coil			18-0713-00
Freezer Box Ass'y	50-3625-00	50-3625-00	
Heater, Defrost			19-0952-01
Thermostat, Def. Term.			19-1048-00
Harness, Evap			19-1652-03
Fan Motor, Evap			19-1221-00
Fan Blade, Evap			19-1223-00
Motor Mount, Evap			10-1478-00
Grill, Evap Fan			10-1479-00
Switch, Power	19-0103-00		19-1006-00
Relay, Power			19-1005-00
Thermostat, Cabinet	19-1031-00	23-5177	19-1018-00
Power Cord	19-0620-00		19-0967-00
Harness, Ebox to Main			19-1675-03
Heater, Cond Pan			19-1688-00
Lampholder			503-248D
Switch, Light			19-1003-00
Lamp			22-0213
Cover, Lamp			44-1034
Heater, Perimeter			19-0966-02
Breaker Trim, Side	10-1485-02	10-1485-02	10-1485-02
Breaker Trim, Top/Btm	10-1485-03	10-1485-03	10-1485-03
Thermometer, Solar	19-1050-03		
Switch, Door			19-0969-00
Hinge, Lower RH	25-0178-09	25-0178-09	25-0178-09
Hinge, Upper RH	25-0178-03	25-0178-03	25-0178-03
Door Assy, RH	51-0172-02	51-0172-02	51-0172-02
Door Closer	25-0178-01	25-0178-01	25-0178-01
Gasket, Door	10-0882-05	10-0882-05	10-0882-05
Handle, Door	25-5055-00	25-5055-00	25-5055-00
Lock, Door	25-0226-00	25-0226-00	25-0226-00
Shelf, Cantilever	15-0325-00	15-0325-00	15-0325-00
Shelf, Bottom	15-0197-03	15-0197-03	15-0197-03
Leg, Adjustable	33-0504-01	33-0504-01	33-0504-01
Front/Control Panel Assy	51-0174-10	51-0174-11	50-2999-44